



3rd Hi-Lumi LHC-LARP  
Annual Meeting 11-15 Nov 2013  
Daresbury Laboratory, GB



# FINAL LAYOUT AND PLANS FOR CRYSTAL COLLIMATION TESTS AT LHC

*Water Scandale*

*on behalf of the UA9 collaboration*

*Special acknowledgements: D. Mirarchi, S. Montesano, S. Redaelli.*



# Outline



- Introduction
- SPS-UA9 layouts
- Recap. of main results
- Activities in the last year
- Prospect for LHC tests
- Conclusions

**UA9 MISSION:** investigate bent crystals as primary collimators in hadron colliders.

- In crystals, particles are subjected to a **coherent interaction** (channeling):
  - ◆ **large angle** possible for high-energy particles;
  - ◆ **reduced probability of nuclear interactions** (diffractive scattering, ion fragmentation/dissociation).
- BUT
  - ◆ **Uncertainties in extrapolating** to high-energy
  - ◆ **technological challenges** (crystal alignment, radiation hardness, thermo-mechanical robustness)

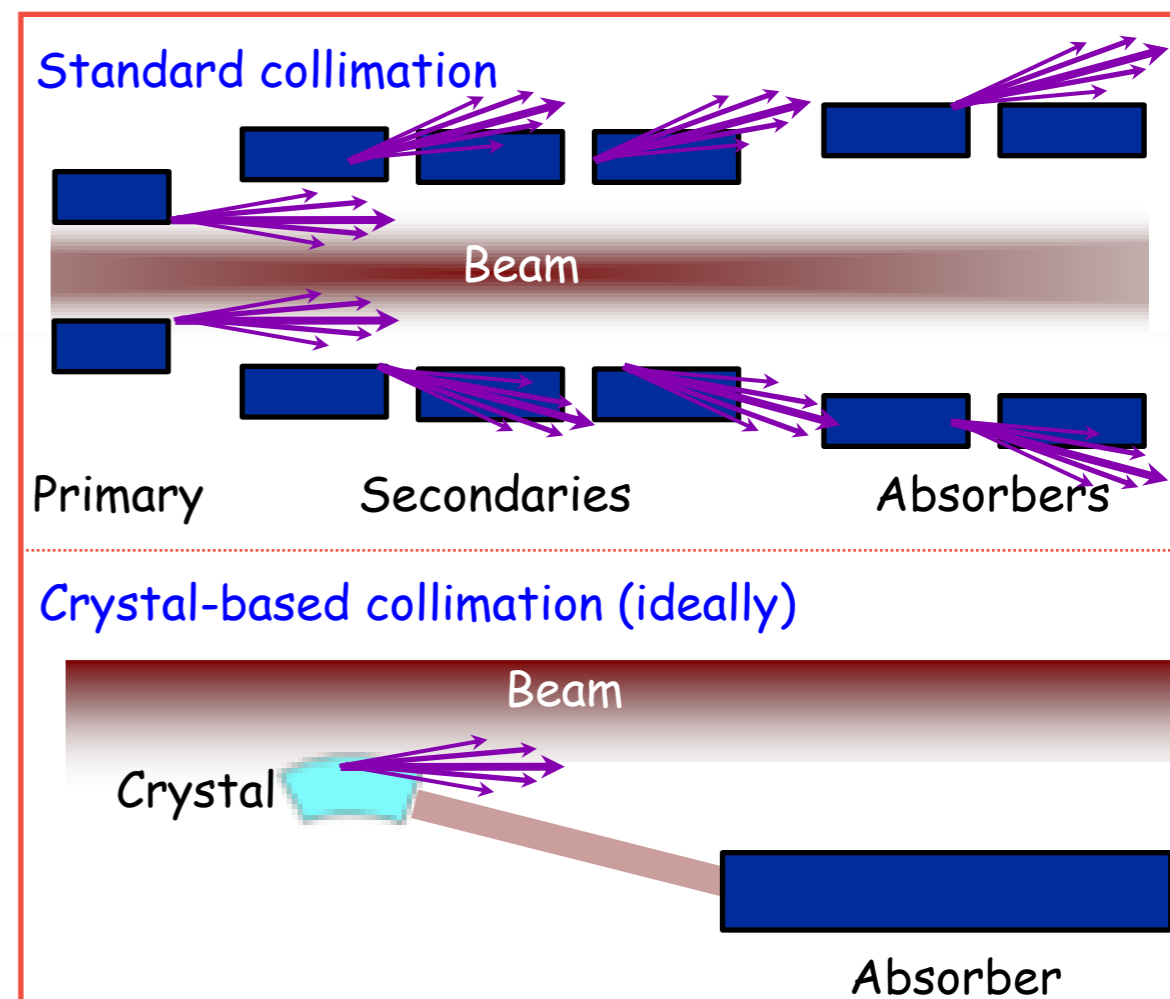
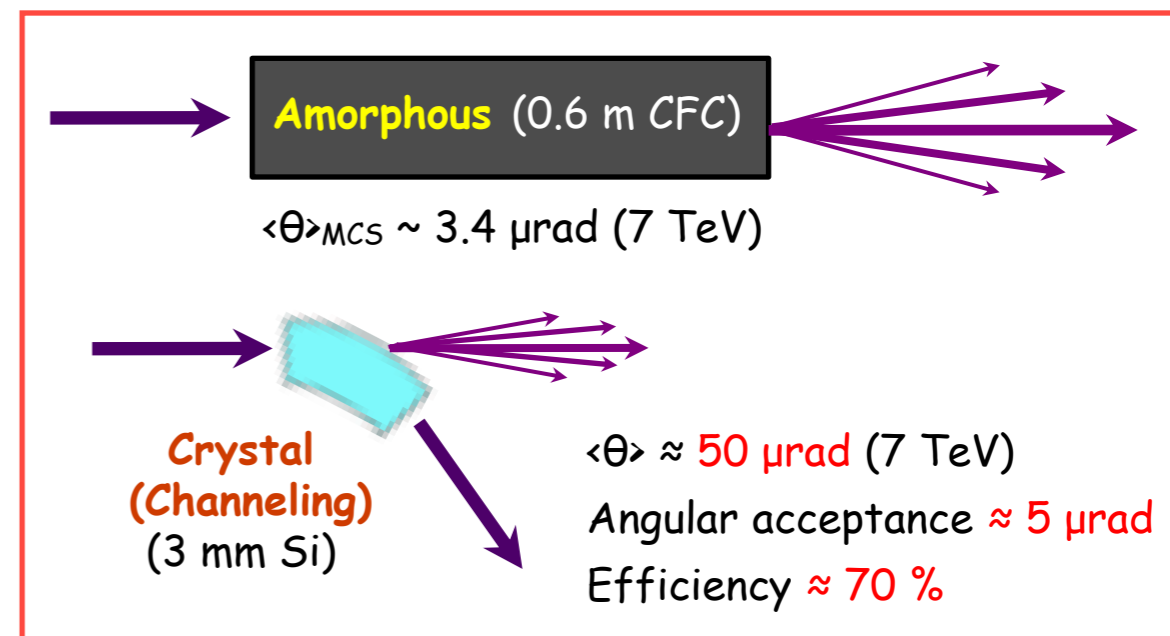
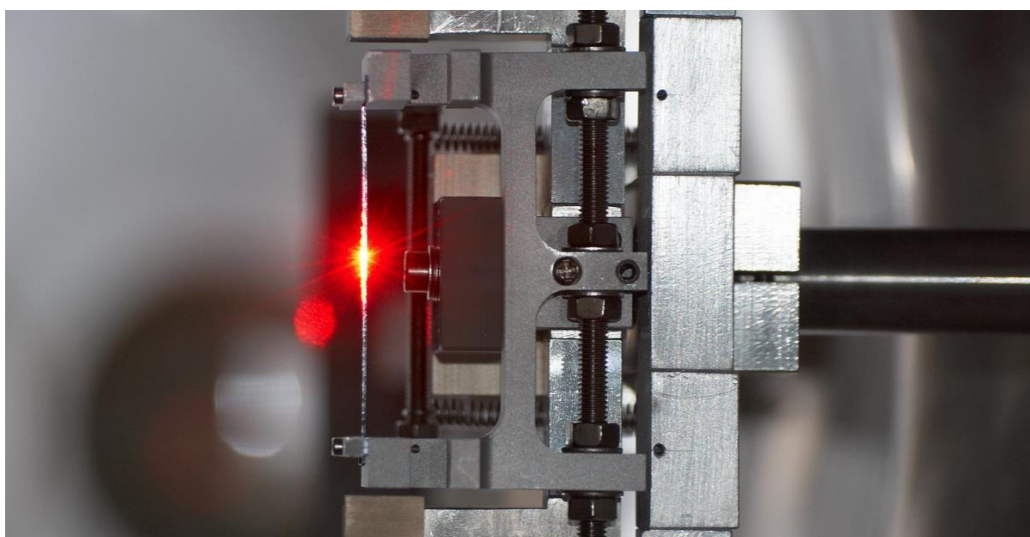



# UA9 experimental achievements



- ❑ **Prototype crystal collimation system in CERN-SPS (~ 5 days/year as from 2009):**
  - ✓ 2009 → First results on the SPS beam collimation with bent crystals.  
(*Physics Letters B*, vol. 692, no. 2, pp. 78-82).
  - ✓ 2010 → Comparative results on collimation of the SPS beam of protons and Pb ions with bent crystals.  
(*Physics Letters B*, vol. 703, no. 5, pp. 547-551).
  - ✓ 2011 → Strong reduction of the off-momentum halo in crystal assisted collimation of the SPS beam.  
(*Physics Letters B*, 714(2-5), 231-236)
  - ✓ 2012 → Optimization of crystal assisted collimation of the SPS beam (halo population reduction in dispersive areas, SPS loss maps, optimized apertures for collimation system elements, ...)  
(*Physics Letters B*, 726 (2013), 182-186)
- ❑ **Test beams at CERN North Area (~ 3 weeks/year as from 2006):**
  - ✓ Study of crystal - beam interactions: characterization of single-pass cross sections.
  - ✓ Characterization of experimental apparatus (goniometers, detectors, ...) prior to SPS installation.
  - ✓ Measurement of crystal properties before installation in CERN-SPS.
- ❑ **New HiRadMat facility (1 experiment for UA9 in 2012)**
  - 2012 → Robustness of crystal against high-energy, high-intensity beam impacts.

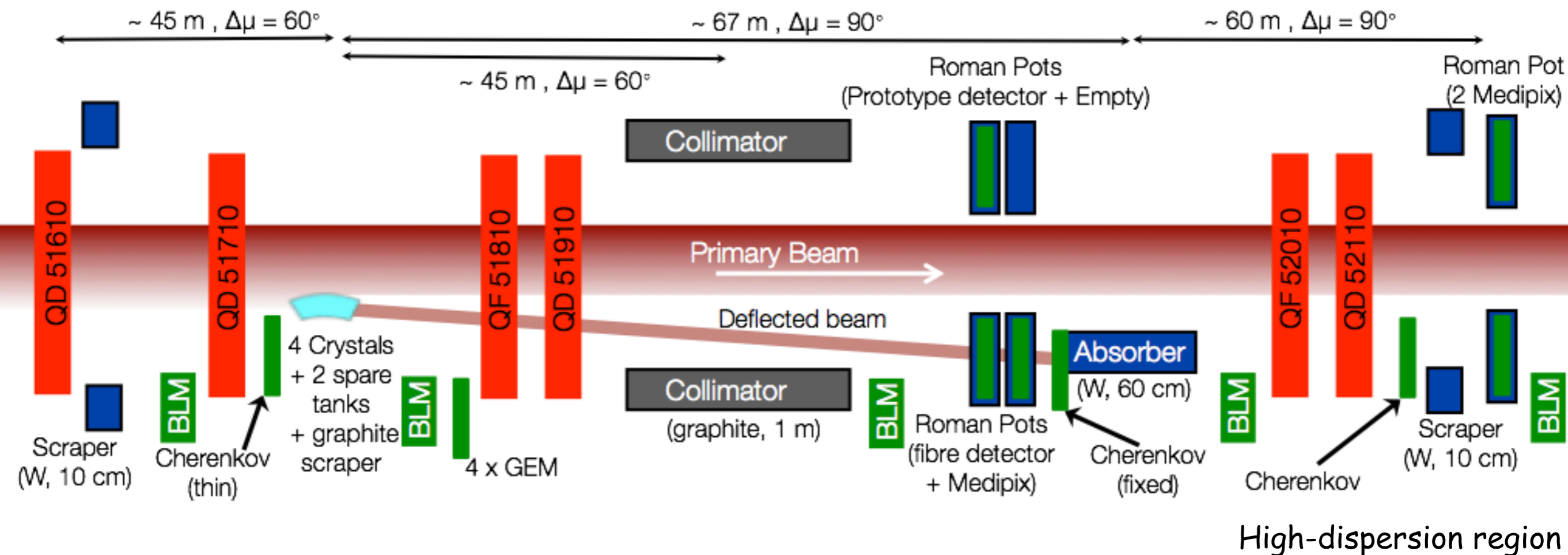

High-dispersion region

Throughout the years, the SPS UA9 setup has evolved thanks to new devices and profited existing installations to achieve a very complete and reliable apparatus that enables:

- ◆ Precise and reliable crystal alignment to the beam (using a two-side LHC collimator prototype).
- ◆ Characterization of local losses through scans of crystal positions/angles and of absorber and detector scans.
- ◆ Precise characterization of channeled beam properties (2D profiles with Medipix images)
- ◆ Analysis of off-momentum losses at dispersive locations through local scraping and diagnostic, representative of the LHC limiting loss locations.

- ❑ **Alignment** (linear and angular) of the crystal is fast and well reproducible.
- ❑ **Multi-turn channeling efficiency**: 70÷80% for protons, 50÷70% for ions.
- ❑ **Channeled beam observed** with the Medipix.
- ❑ **Loss rate reduction at crystal**: 20x for protons, 7x for ions.
- ❑ **Off-momentum loss reduction**: 6x for protons, 7x for ions.  
 → *This is what matters for the LHC, limited by dispersion losses!*
- ❑ **Loss maps**: consistent reduction of the losses around the full ring when comparing crystal in channeling and crystal in amorphous.
- ❑ **Dependence of the off-momentum leakage on the clearance between crystal and absorber.**
- ❑ **Test multi-strip crystals in volume-reflection**

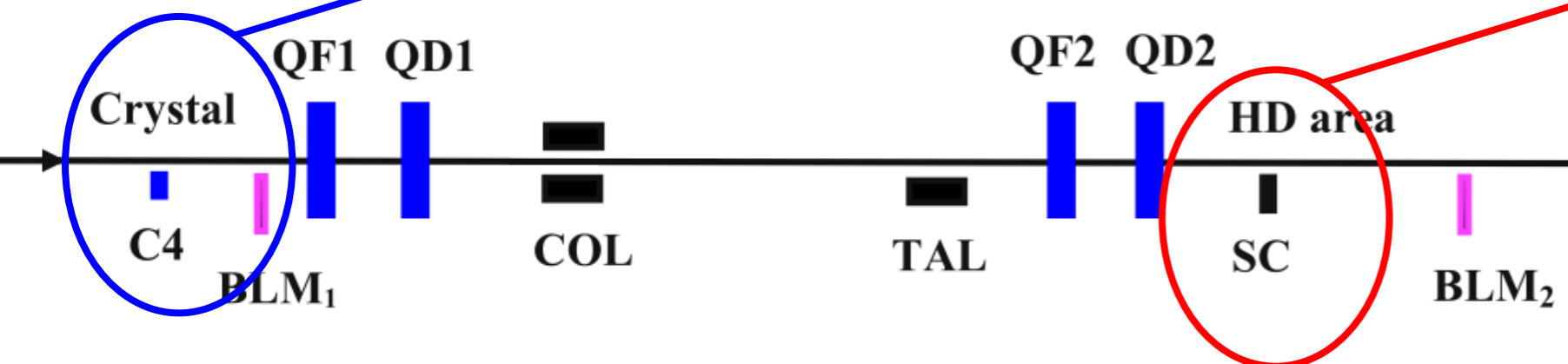
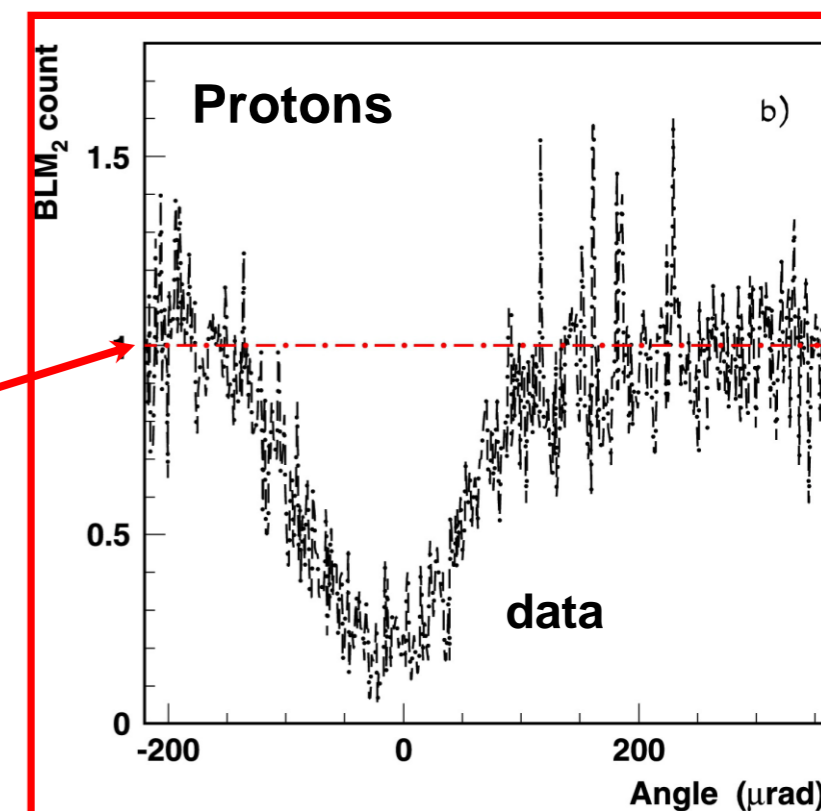
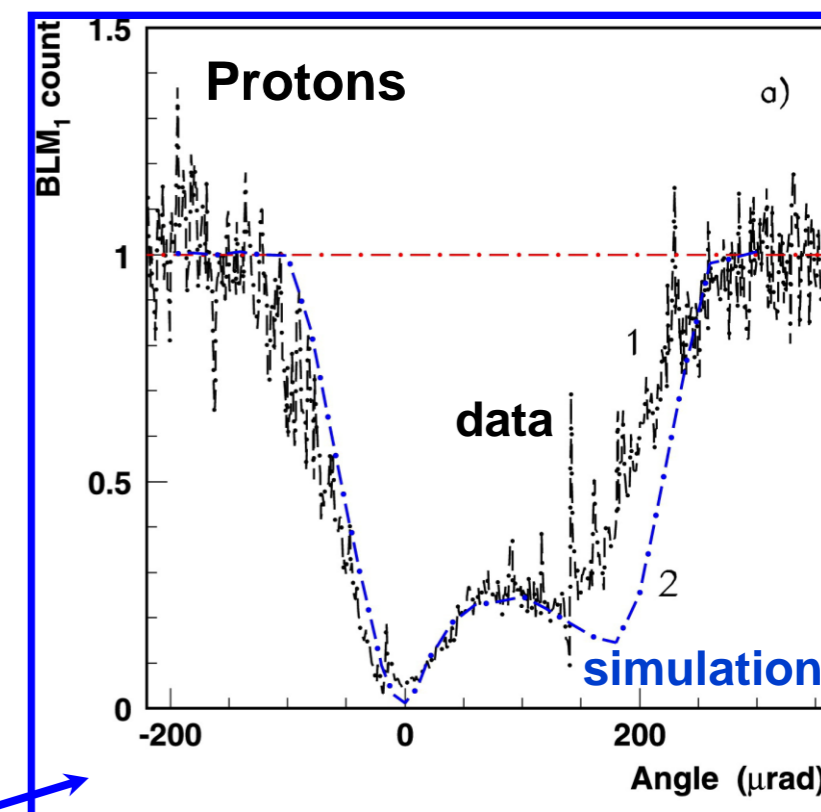

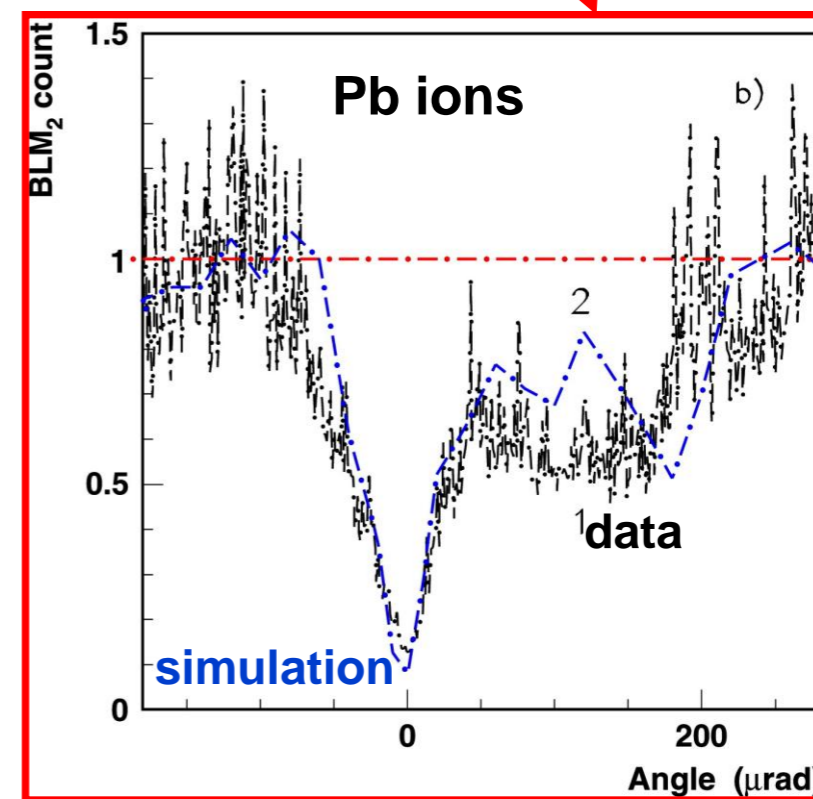
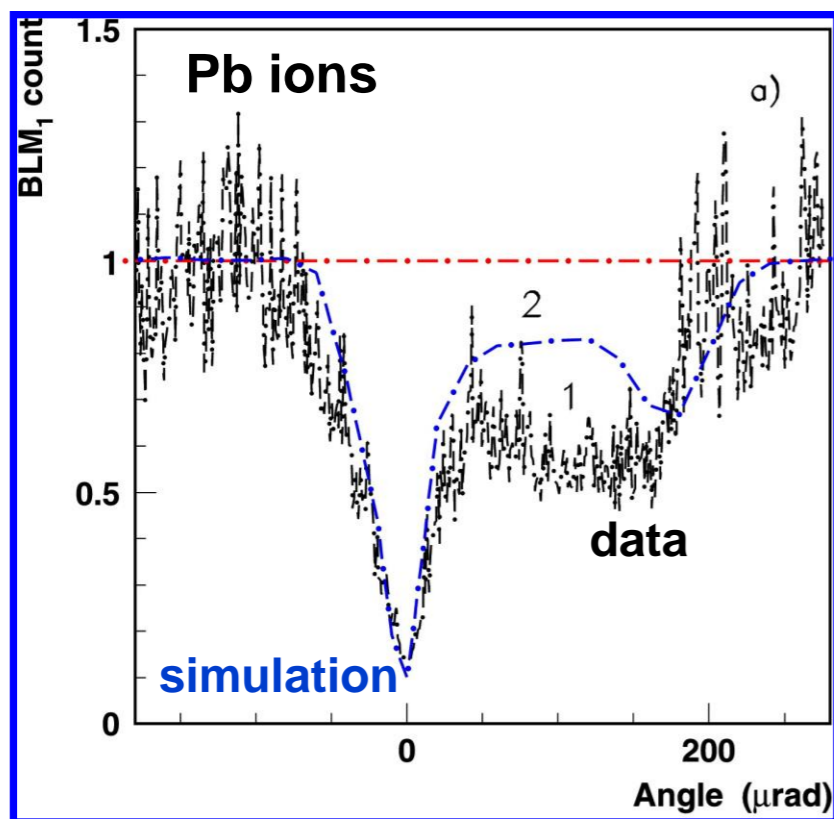

Loss maps are beam loss monitor rates registered along the accelerator.

Loss map measurement is not trivial in UA9:

- the SPS BLM system is optimized for high-intensity operation in pulsed mode
- UA9 operates at low intensity and low loss rate.

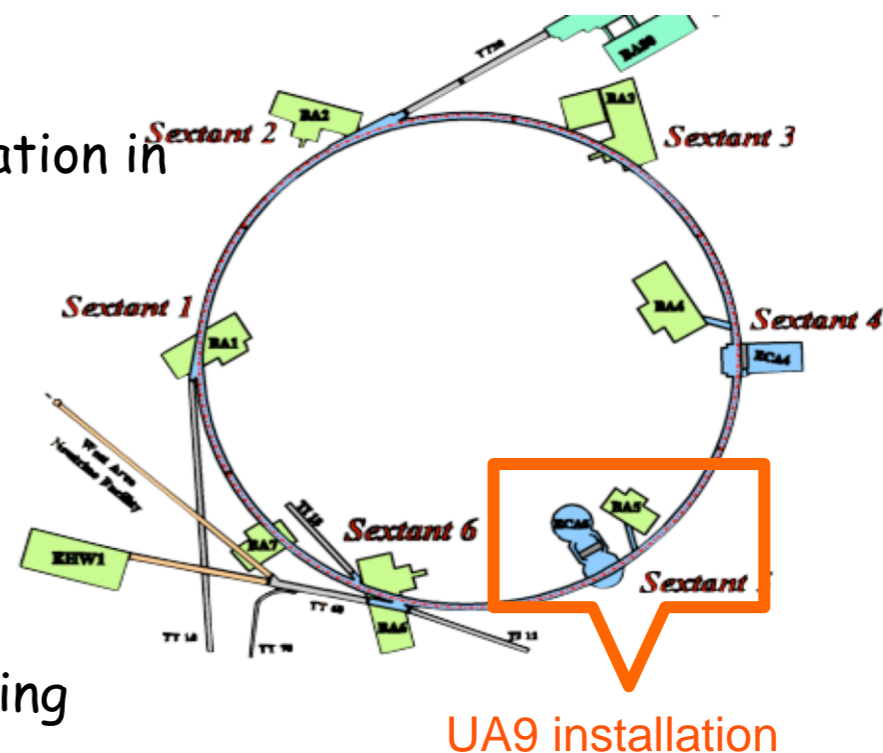

Loss map measurement in 2012:

- ◆ total intensity:  $3.3 \times 10^{13}$ , 4 x 72 bunches with 25 ns spacing
- ◆ Loss reduction in the entire ring (in the reliable BLMs)

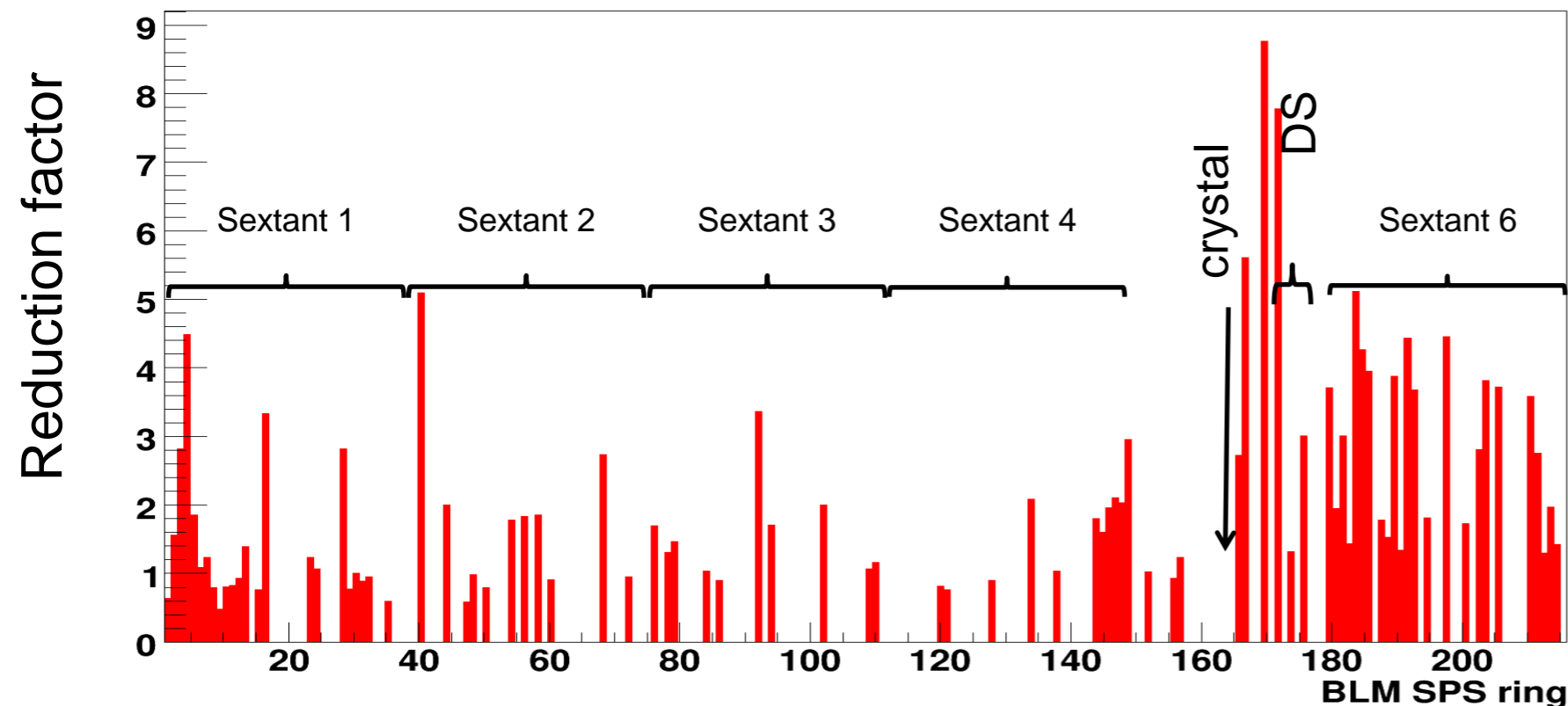

What is the dose that a crystal can withstand while ensuring good channeling?

- ❑ **HRMT16-UA9CRY** (HiRadMat facility, **November 2012**): 440 GeV protons, up to **288 bunches of  $1.1 \times 10^{11}$  (25 ns)**

  - ✓ **no apparent damage to the crystal from accurate visual inspection**
  - ✧ more tests planned to assess possible crystal lattice damage
  - ✧ A. Lechner et al., IPAC2013.
  
- ❑ **IHEP U-70** (Biryukov et al, NIMB 234, 23-30): 70 GeV protons, 50 ms spills of  **$10^{14}$  protons every 9.6 s**, several minutes irradiation

  - ✓ **channeling efficiency unchanged.**
  
- ❑ **SPS North Area - NA48** (Biino et al, CERN-SL-96-30-EA): 400 GeV protons, 2.4 s spill of  $5 \times 10^{12}$  p every 14.4 s, one year irradiation,  **$2.4 \times 10^{20}$  protons/cm<sup>2</sup>** in total,

  - ✓ **channeling efficiency reduced by 30%.**

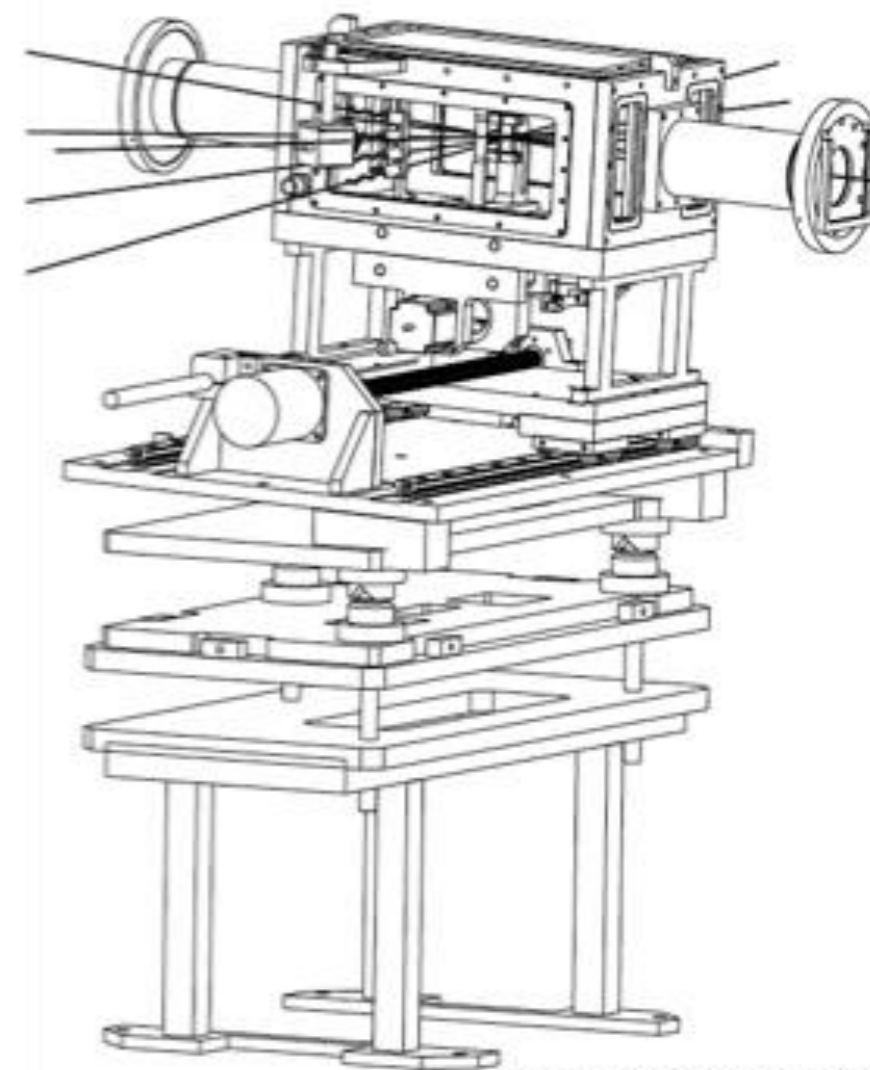
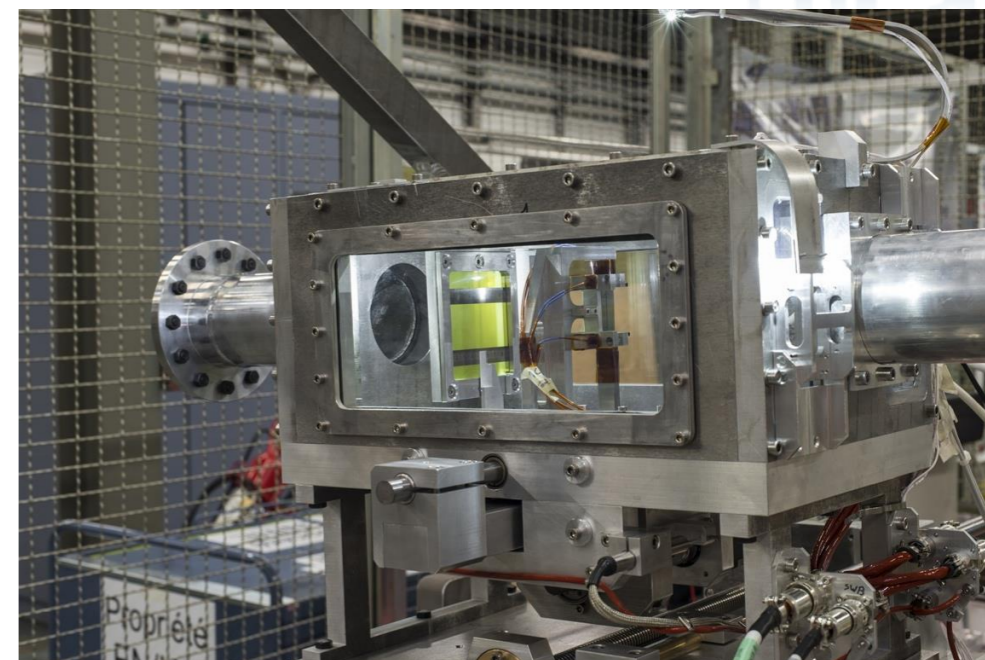

Courtesy of Frederic Loprete



# Preparation for LHC beam tests



- Aim of the experiment
  - ✓ a **direct comparison** of the **collimation cleaning efficiency** with and without the use of crystals.
- Design principles
  - ✓ Install the experiment in **IR7** (betatron collimation insertion) in view of low intensity MDs.
  - ✓ Use **existing devices** (collimators and instrumentation).
  - ✓ Test simultaneously **horizontal and vertical collimation**, on a single beam.
  - ✓ Define layout through **deflected beam orbit and cleaning simulation**.
  - ✓ Ensure simulated performance better than in the baseline cleaning system.
- ECR for the installation of UA9 equipment in IR7
  - ✓ **Cabling** for complete experiment;
  - ✓ Installation of **2 goniometers**;
  - ✓ Space reservations for **in-vacuum Cherenkov detectors**.  
(nice to have but not essential for the initially feasibility demonstration)
  - ✓ **Controls and interlock** strategy for integration into the LHC system.

## Schematic layout

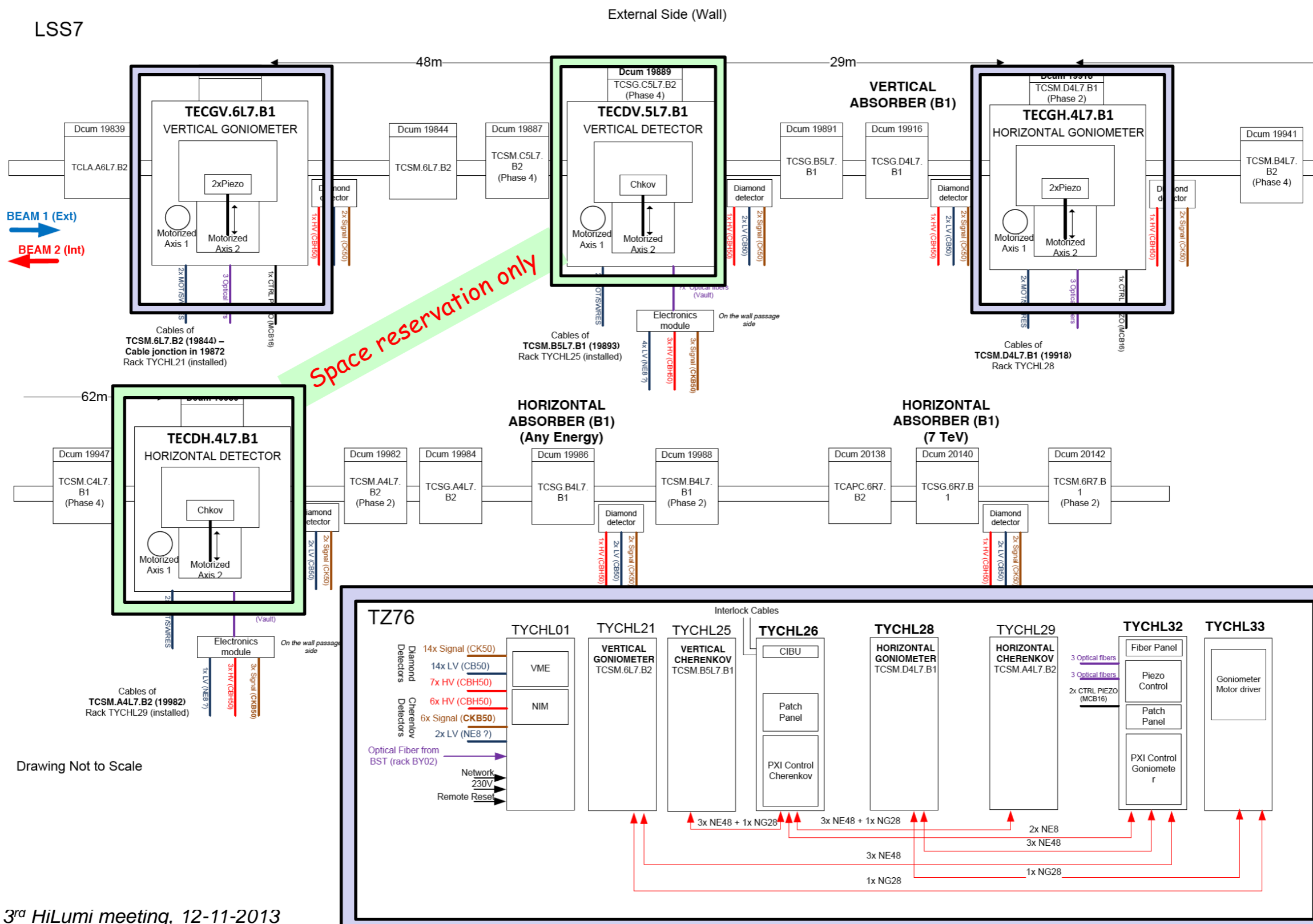

- ✓ Linear stage based on stepping motors
- ✓ Rotational stage based on closed loop controlled piezo-electric device
- ✓ In parking position same impedance as the vacuum pipe.
- ✓ The goniometer support uses quick plug concept as the LHC collimators.
- ✓ Can be baked-up to 110 ° C because of Piezo Curie Temperature.
- ✓ New Piezo actuators able to withstand up to 220 ° C under study.

Parking position

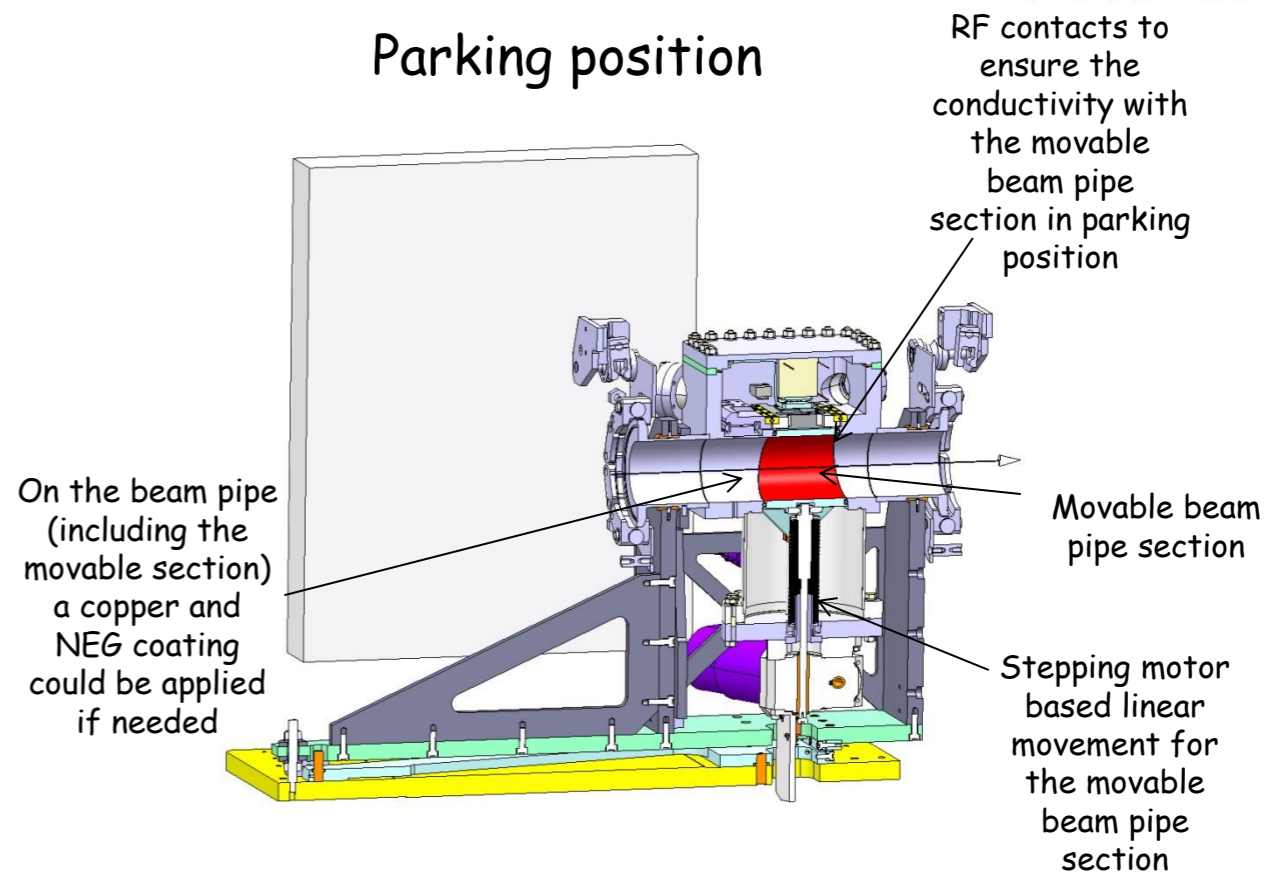

Operational position

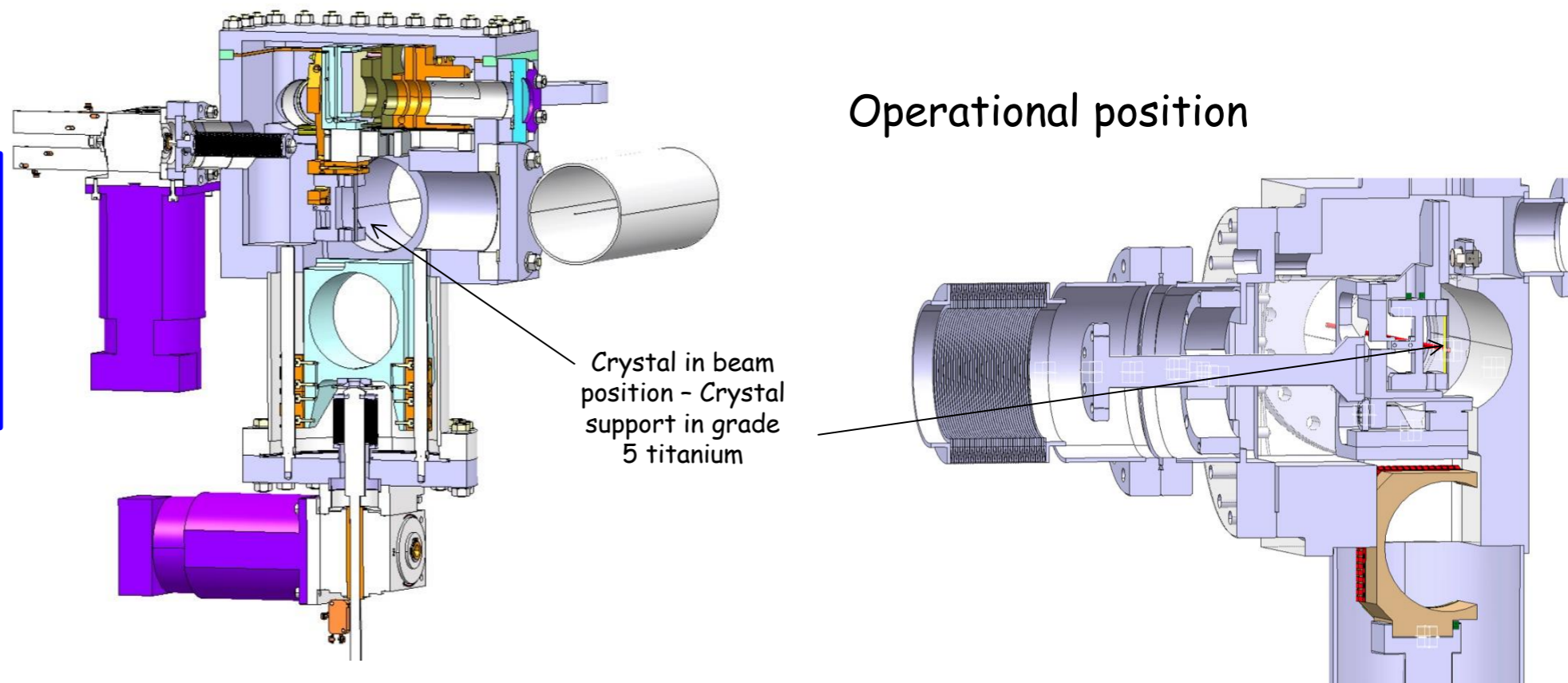

Linear Stroke: 60 mm  
 Linear resolution: 5  $\mu\text{m}$   
 Total angular range :  $\pm 10$  mrad  
 Angle resolution: 0.1  $\mu\text{rad}$   
 Angle accuracy:  $\pm 1$   $\mu\text{rad}$

Very challenging to find the best compromise between parameters for injection and collision energy

Best cleaning performance in channeling mode → small angle, short crystal

Safe margin of clearance from the magnet aperture → small angle

Large impact parameter onto the collimations → large angle

Same layout at injection and collision energy → large angle

*Optimal Crystal parameters bending angle=50 $\mu$ rad; length=4mm  
(bending radius bigger than 4 critical bending radius)*

*Example of investigations for an optimal clearance for a H crystal close to primary collimators.*

*For H and V planes, compared 2 layouts (4 cases) with crystals close to primary or close to IR7 (lower radiations).*

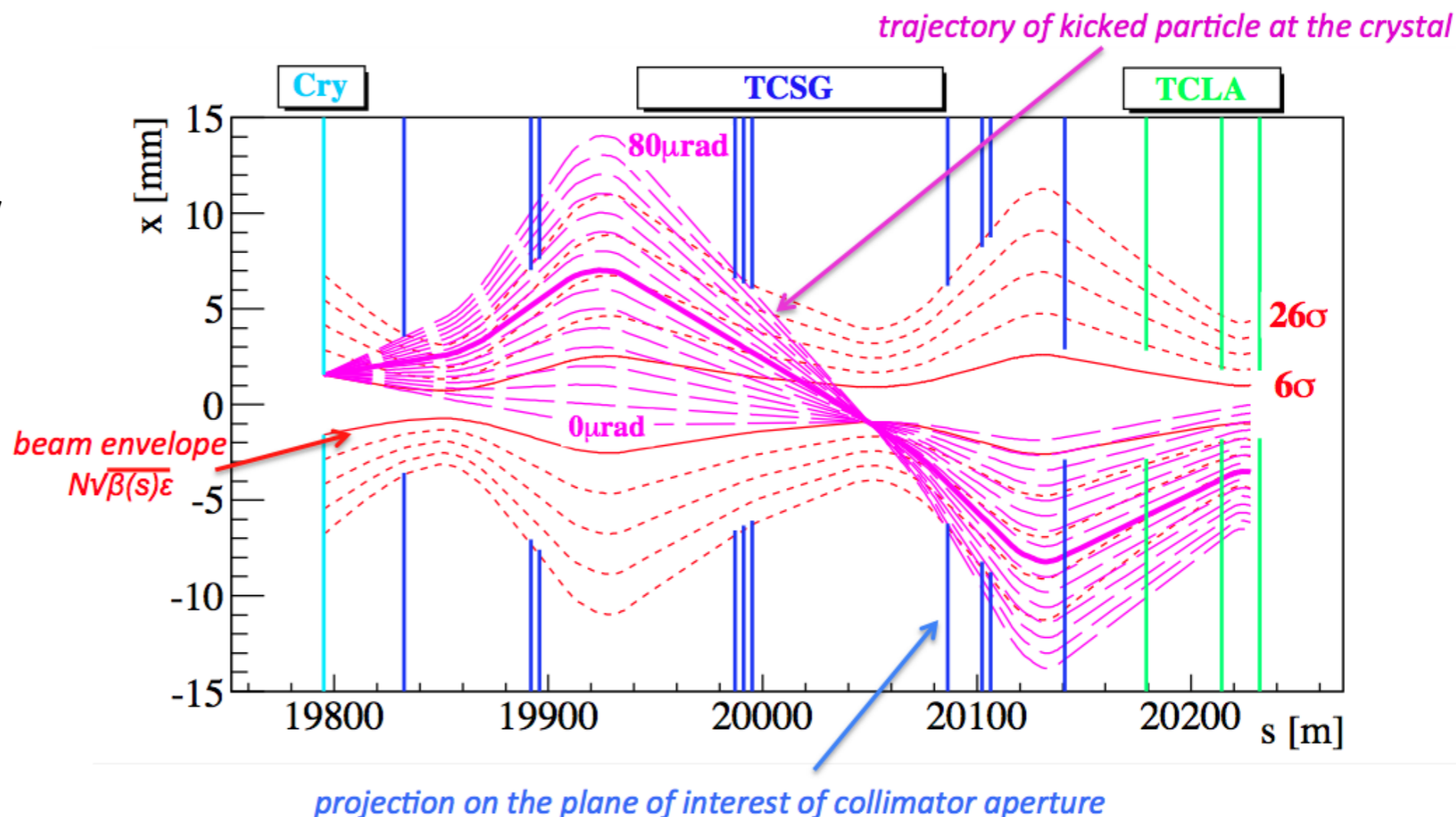

- Several crystal routine available:
  - Integration of equation of motion vs. faster Monte-Carlo approach for high-statistics.
- Benchmark of H8 data critical.
  - Overall good agreement.
- Benchmark of different routine used to validate the scaling to 7 TeV.
- Monte-Carlo routine used for LHC predictions

*Example of simulations "H8-like" (single crystal traversal) for an optimal channeling performance*

$\theta[\mu\text{rad}]\rightarrow$ $l[\text{mm}]\downarrow$	20	40	60	80
3	CH: 84.18% VR: 13.55%	CH: 72.98% VR: 24.49%	CH: 61.84% VR: 35.38%	
4	CH: 86.38% VR: 10.86%	CH: 77.97% VR: 19.01%	CH: 69.76% VR: 26.99%	CH: 61.10% VR: 35.37%

$\theta[\mu\text{rad}]\rightarrow$ $l[\text{mm}]\downarrow$	20	40	60	80
3	CH: 83.19% VR: 14.00%	CH: 74.15% VR: 22.40%	CH: 63.05% VR: 33.50%	
4	CH: 84.98% VR: 12.00%	CH: 78.82% VR: 18.00%	CH: 70.81% VR: 25.20%	CH: 62.54% VR: 33.30%



Using crystal emulator in SixTrack

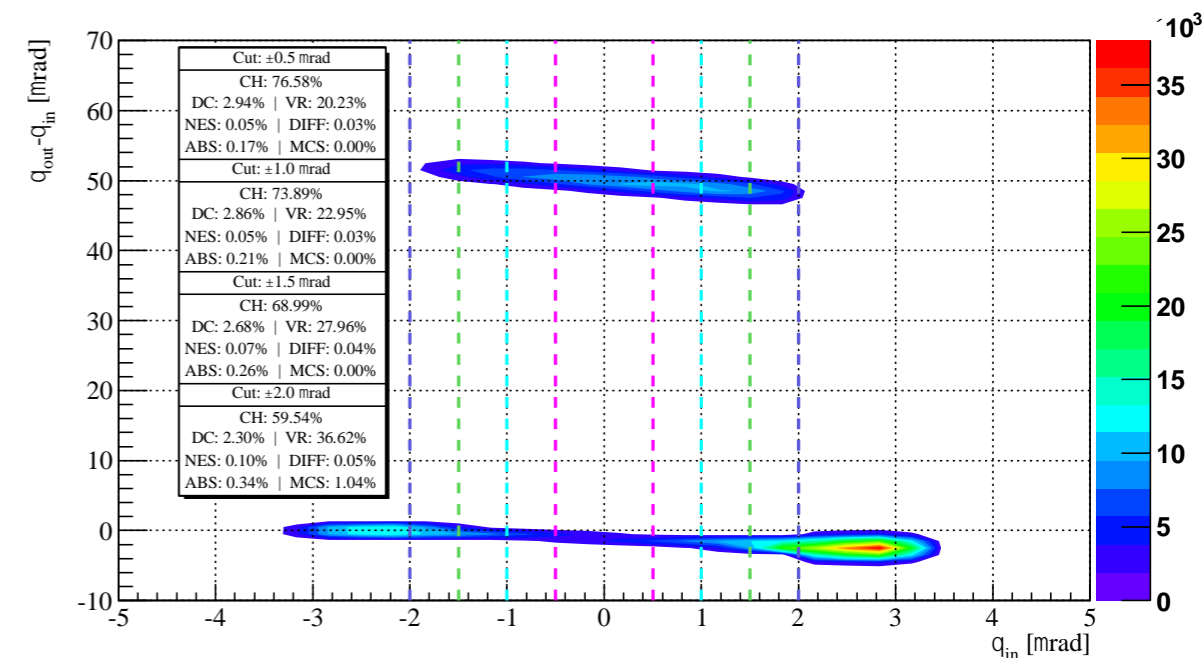

Using stand-alone fully analytical crystal simulator

## Present system

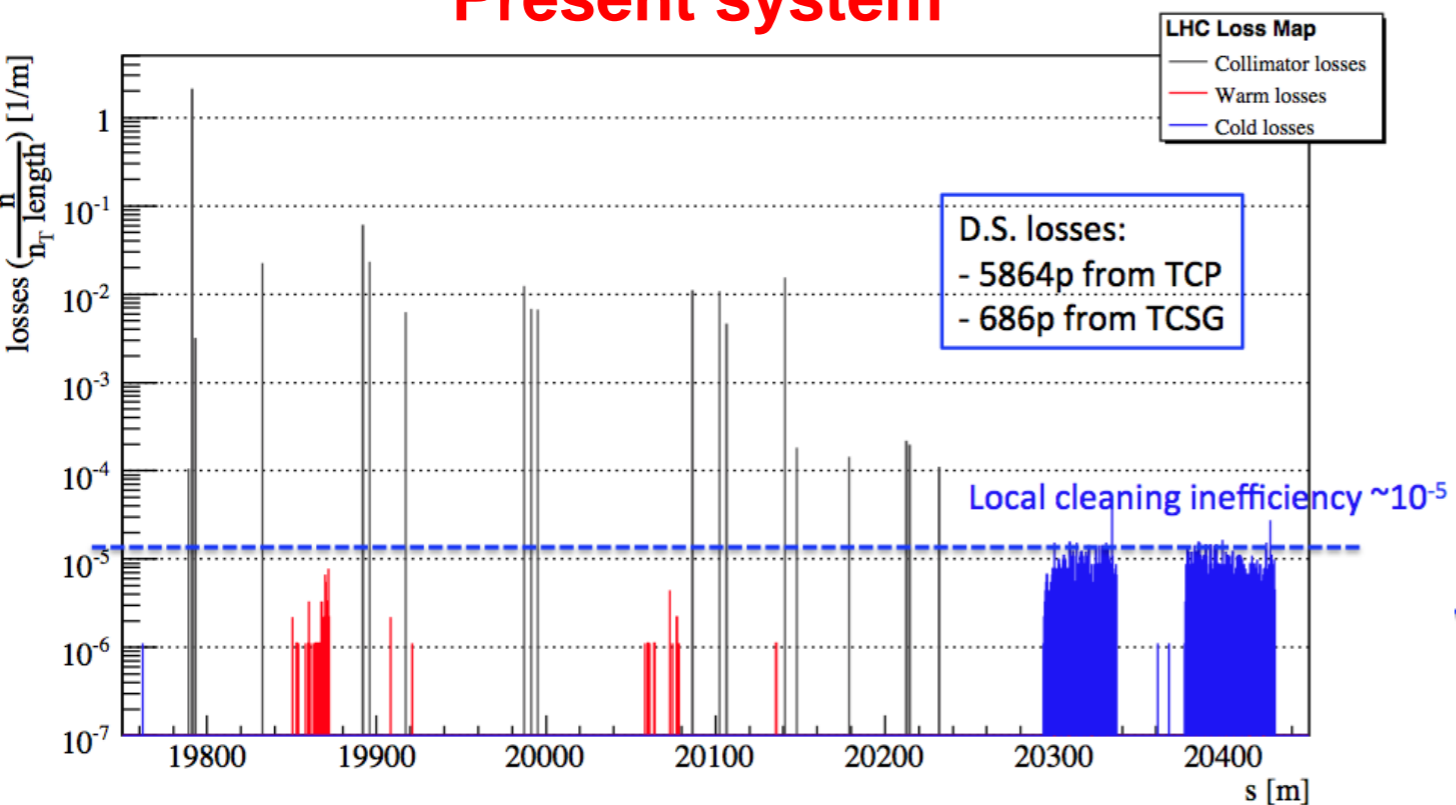

## Crystal channeling

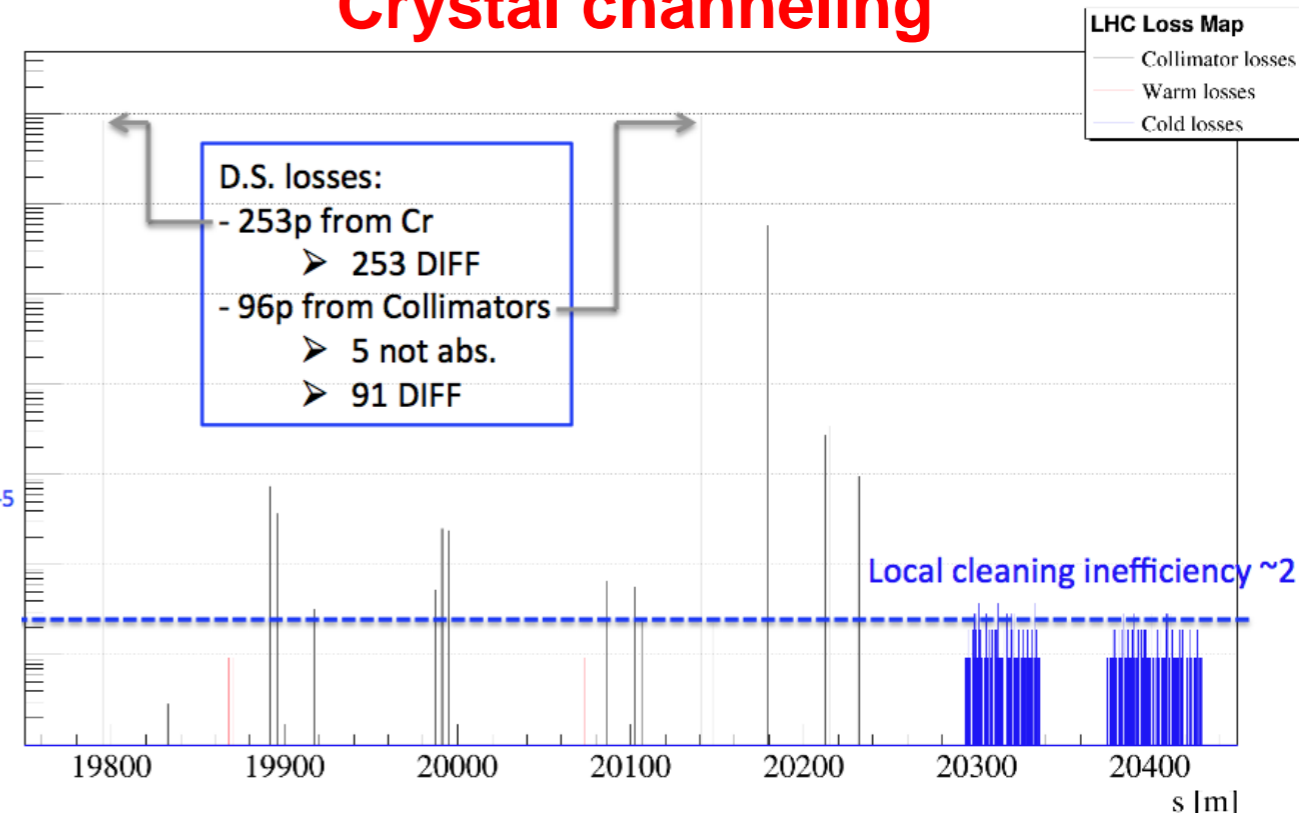

According to simulations, the proposed layout and crystals should improve cleaning by a factor  $\sim 5-10$ .

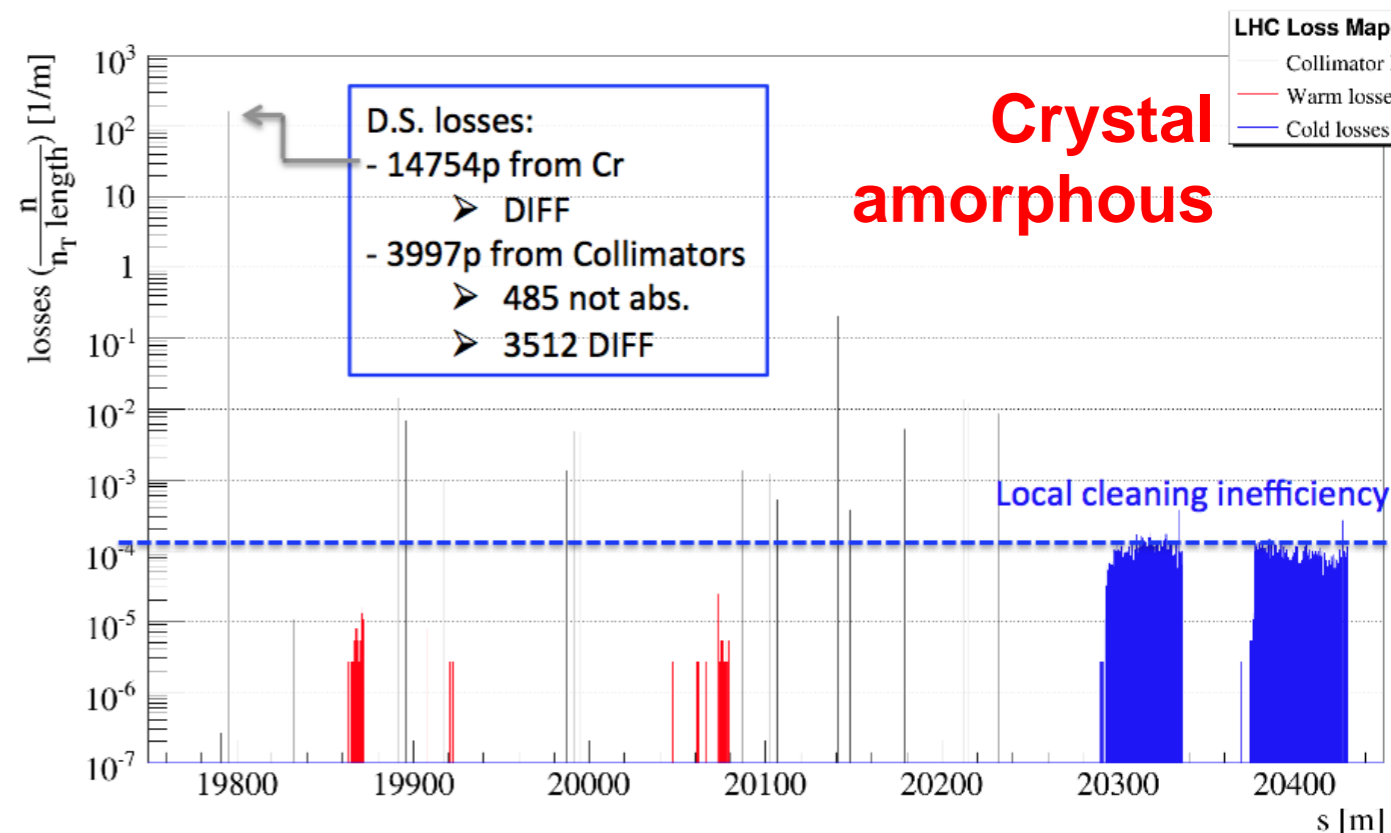



# Overview on LHC tests



## *Preliminary tests possible after LS1:*

- during the 2015
- ✓ Machine Development (MD) devoted to high priority tests for the Machine Commissioning
- ✓ possibility to get few hours for first conceptual tests of channeling extraction at the LHC
  - during the 2016
- ✓ possibility to get few dedicated MD on the LHC (like in the SPS during the past years)

## *Preliminary plan for machine conditions during the first tests in 2016 (with the LHC dedicated to us):*

- low intensity
  - top energy (main goal) & injection
- full chain of secondary collimators (TCSG) in place

*then...*

- higher intensity (still within safe boundaries → total circulating intensity:  $\sim 5 \times 10^{11}$  p @ 450 GeV /  $\sim 5 \times 10^9$  p @ 7 TeV)
  - possibility “to play” with the TCSGs settings

## *Scope of the tests:*

- Can crystal collimation compete with the present very good cleaning system?
  - Uncertainty for the scaling to higher energy (e.g.: single diffractive losses).
- Operational challenges much more complex than at the SPS (ramp, squeeze, etc...)
  - Some outstanding machine protection concerns must be addressed.



# Conclusions



- ☑ The main UA9 activities of the last years were reported.
  - *performance encouraging for a test in LHC*
  - *focus on simulations, analysis, detector and goniometer technology.*
- ☑ The SPS apparatus has matured to a complete setup that addressed various key points for the crystal-based collimation in accelerators.
  - *Single-pass setup in SPS-NA (+HRM) and multi-turn setup in the SPS.*
  - *A list of key achievements was given: alignment, loss rate reduction, loss maps, cleaning of dispersion areas.*
- ☑ New crystal robustness experiment in HiRadMat → soon final results.
- ☑ Recent results include a better understanding of crystal modeling and a development of new detector concepts (under tests at FNL, Rome).
- ☑ Important work on the definition of a crystal experiment at the LHC
  - *Produced layouts for low-intensity feasibility studies. ECR under approval.*
- ☑ It is crucial to continue with high priority the UA9 activities with SPS and North Area beams to be well prepared for the LHC challenges.



# Spare slides



# Integration horizontal goniometer

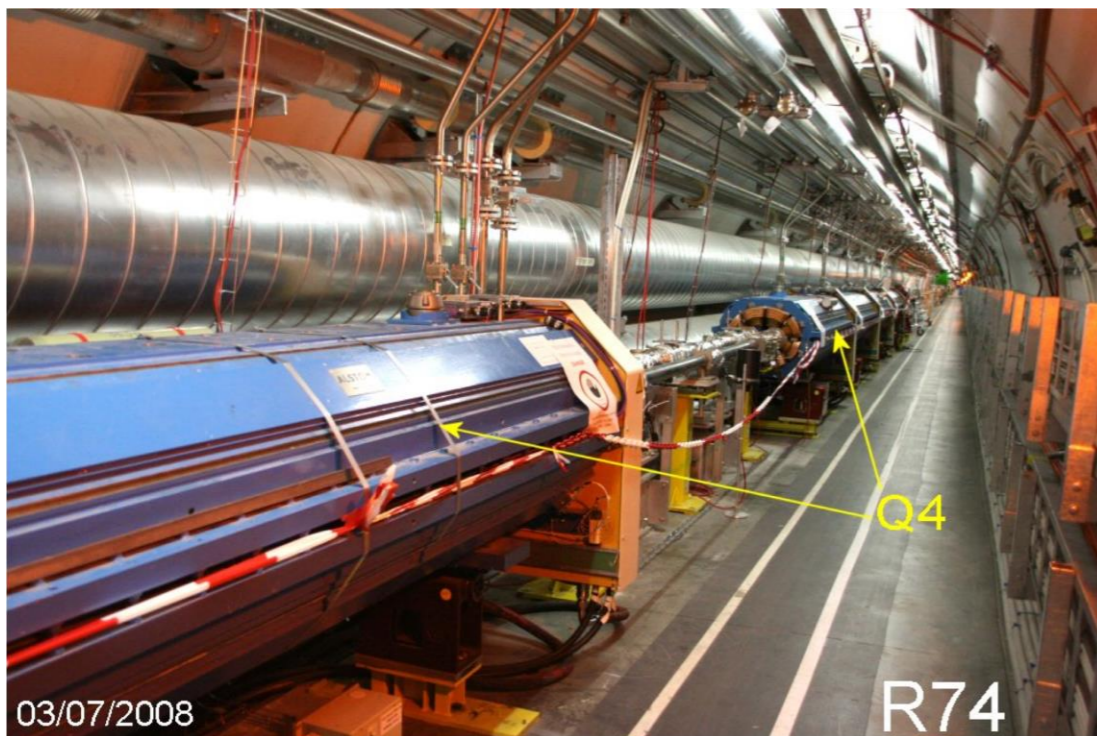
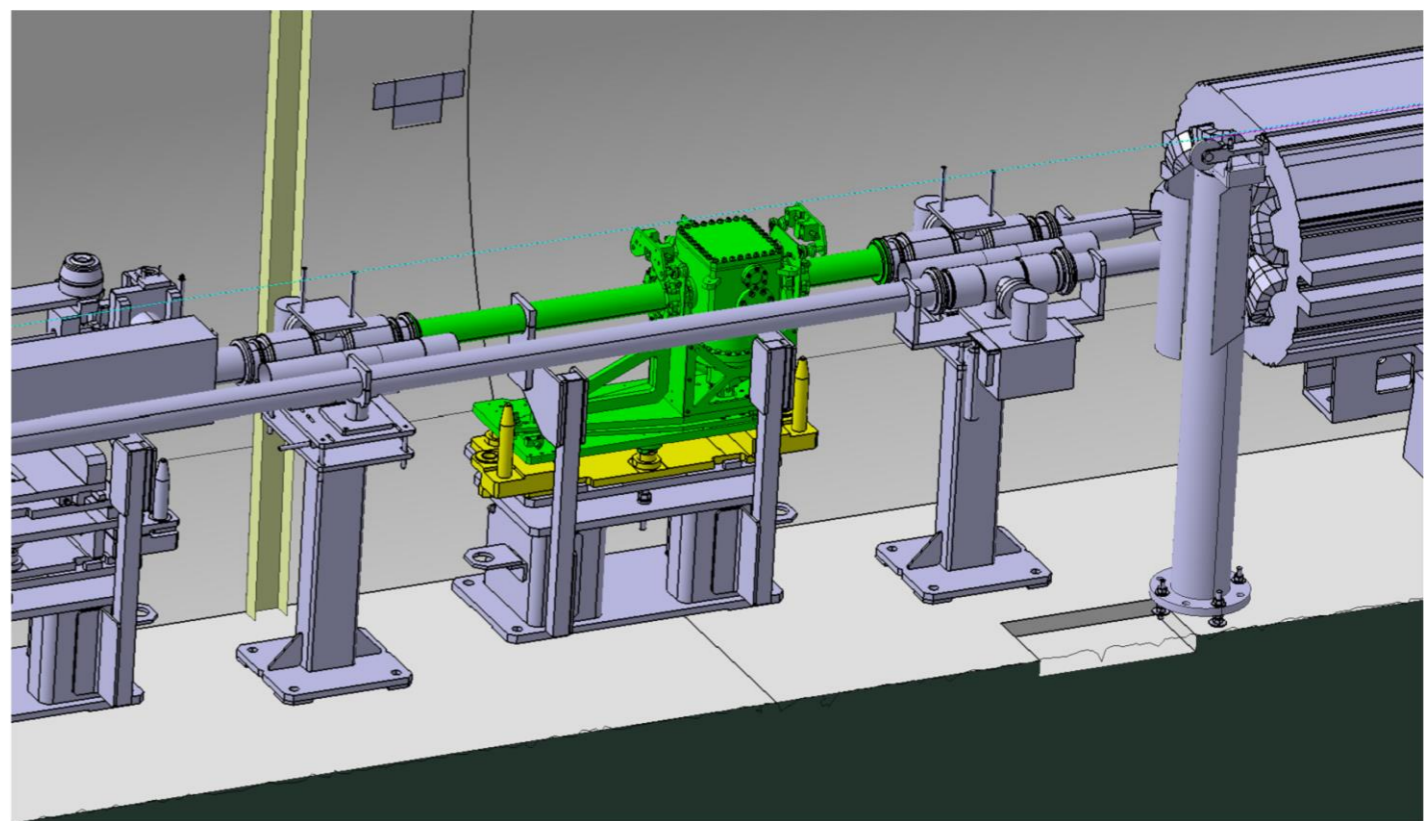
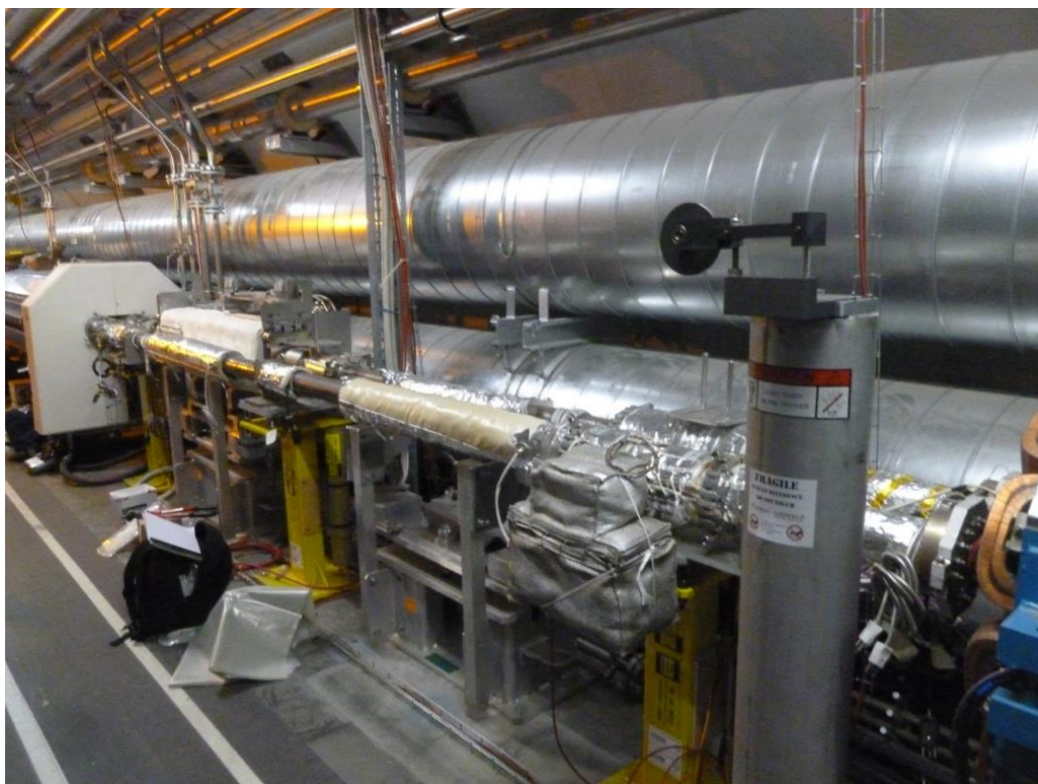

# Integration vertical goniometer

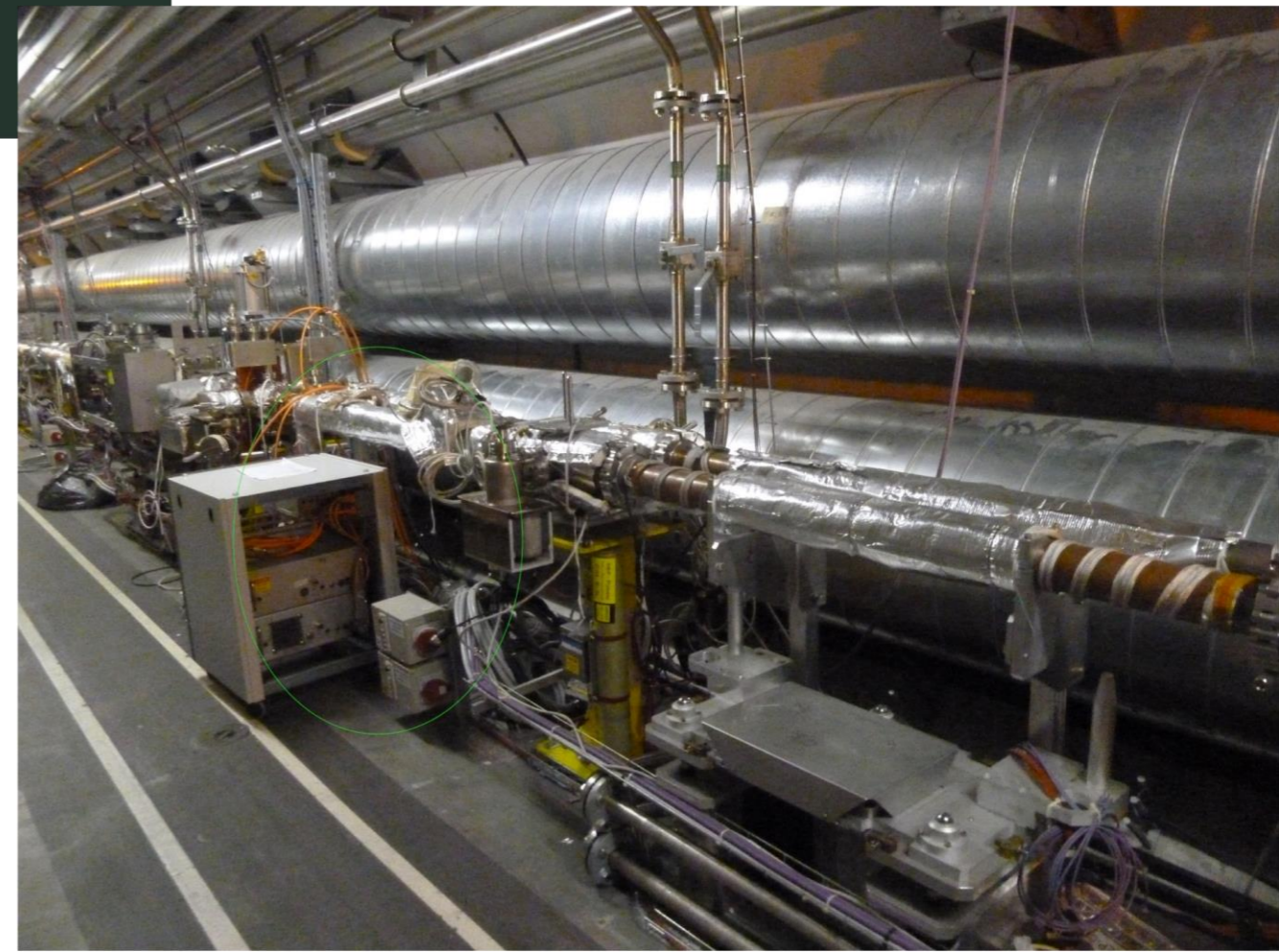
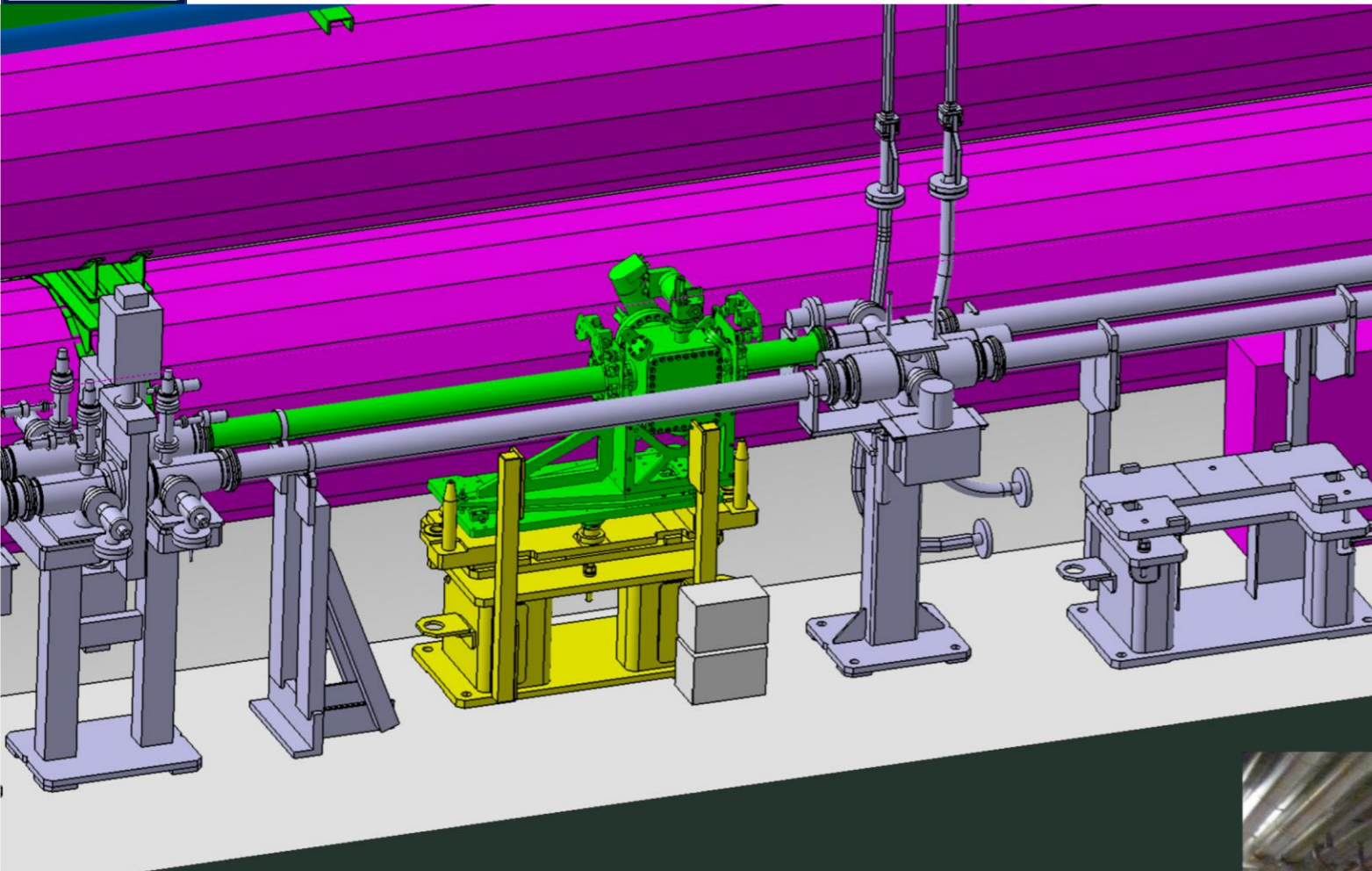

## Locations of the future Cherenkov detectors



26.09.2013

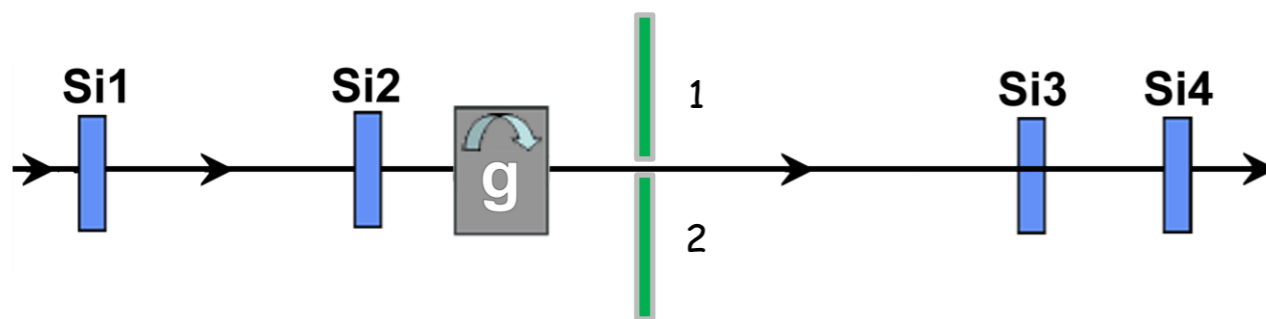

Expected coincidences probability  $F_{12}=0.655$

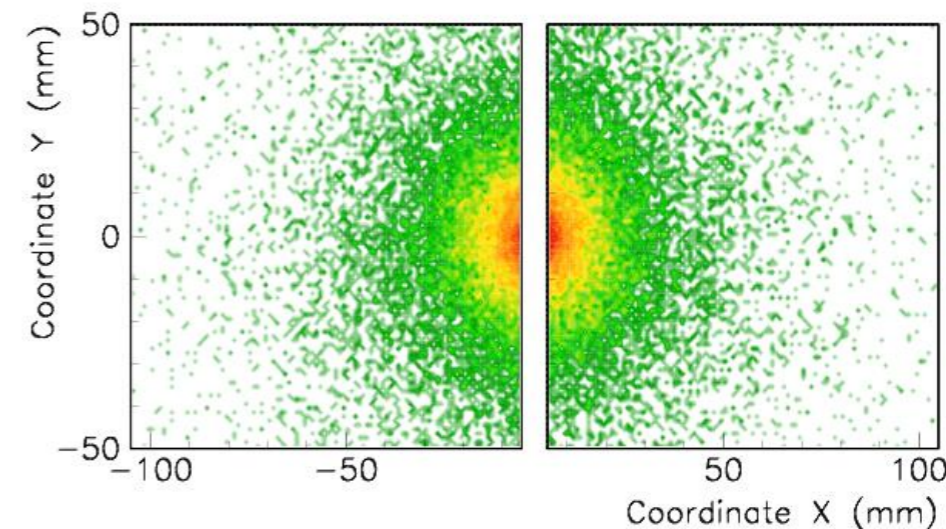

Distributions of secondary particles generated in inelastic interactions according to FRITIOF model

For amorphous orientation  $P_{in}^{am}=0.504\%$

Interaction probability for VR is larger by 3-4% than  $P_{am}$

Interaction probability for channeling is  $\sim 3$  times smaller than  $P_{am}$

Discrepancy between data and simulation in channeling mode at small cutting angles due to goniometer inaccuracy and crystal torsion

