



Power Converters and Power Quality II

**CERN Accelerator School on Power Converters
Baden, Friday 9th May 2014**

Dr. Daniel Siemaszko

Power Converters and Power Quality II Outline

- Active power converters for grid connection
 - Power converters for active front ends.
 - Vector control of voltage source inverters.
 - CERN ongoing projects.
- Introduction to network asymmetries
 - Network unbalances and faults.
 - Network strength as seen from Point of Common Coupling (PCC).
- Grid synchronization
 - Synchronous reference frame PLL.
 - Synchronization to asymmetric networks.
- Control of power converters connected to asymmetric grids
 - Classic current control
 - Current control under unbalanced phase voltages.
 - Double frame control for phase currents.

Active power converters for grid connection

- **Passive front end** converters are highly reliable and need no control.
- However, the power factor of about 0.75, requires the **use of static VAR compensators** when a lot of diode rectifier based converters are installed.
- The use of active power converters as active front end converters allows the **full control of the power factor and injected harmonics** together with reactive power compensation.
- The use of active front-end converters allows to **control the DC-link voltage** that may be used by several loads and converters.
- **Vector control** of voltage source inverter is **simple and reliable**, it is adopted by most of the industry.

Power converters for active front ends

- Voltage Source Inverter (VSI)

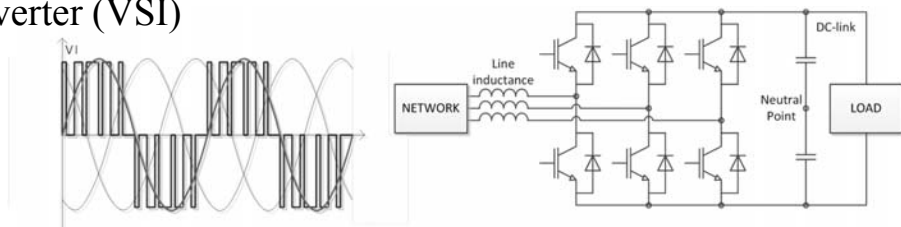

- Neutral Point Clamped (NPC-VSI)

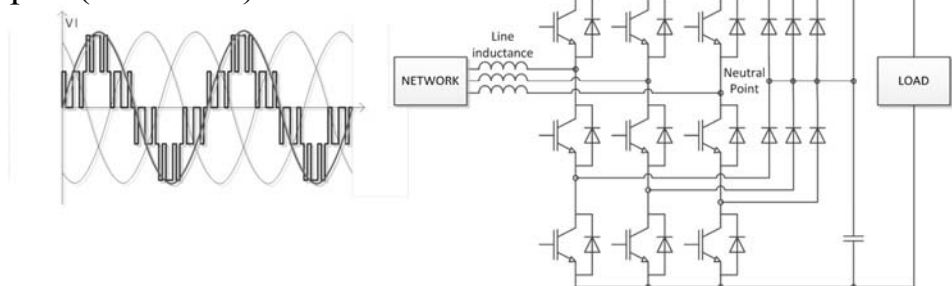

Vector control of voltage source inverters

- VSI and vector control allow to adapt the phase of the current taken from (or injected to) the grid.

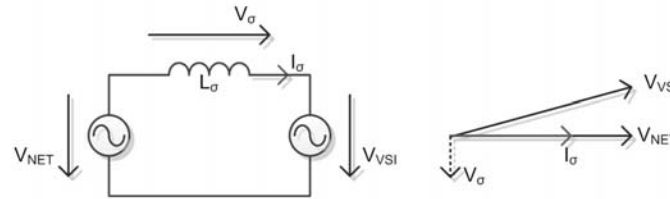

- Control of power quality factor by setting the converter voltage vector in a way to get the current space vector in phase with the voltage space vector.
- Reactive power compensation can be done on the network by adapting the phase of the current space vector. No Static VAR Compensator needed.
- Harmonics can be compensated by control, if controller's bandwidth and converter allow it. No other active harmonic compensation needed.

CERN ongoing projects

- In the frame of the Booster upgrade, a 20MVA active front-end is projected, studies are on-going on power quality and robustness against network disturbances (F. Boattini).
- In the frame of energy recovery and modular approach topology studies for LINAC 4, studies are on-going of the front-end side for the MW max range (G. Le Godec).
- For now network is relatively strong for all applications, in the future, with the increase of power (CLIC, HL-LHC, Future Circular Collider), the network might become weaker for given applications, massive use of SVCs and passive front ends might be replaced for active front-end solutions.

Introduction to Network Asymmetries

- **Network as seen from the Point of Common Coupling (PCC)** is not an infinite ideal voltage source, its strength must be considered.
- **Control of a grid converter** implies rejection of its own **harmonics** generated by switching devices and network disturbances.
- One common network disturbance in **weak networks** is the **asymmetry in phases**, among others such as phase dips and phase steps.

Network unbalances and faults

- In ideal operation, the voltage vector draws a perfect circle in the Cartesian plane (or $\alpha\beta$ plane)

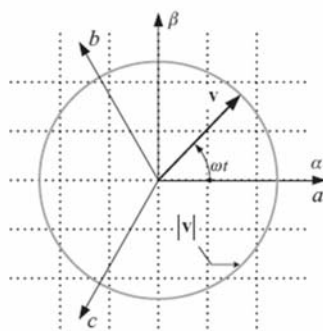

$$\mathbf{v}_{abc} = \begin{bmatrix} v_a \\ v_b \\ v_c \end{bmatrix} = V \begin{bmatrix} \cos(\omega t + \phi) \\ \cos(\omega t - \frac{2\pi}{3} + \phi) \\ \cos(\omega t + \frac{2\pi}{3} + \phi) \end{bmatrix}$$
$$|v| = \sqrt{v_a^2 + v_b^2 + v_c^2} = \sqrt{\frac{3}{2}}V$$

Network unbalances and faults

- The three phase voltages are represented in the $\alpha\beta 0$ stationary reference frame as three vectors which can be transformed in the dq0 synchronous reference rotating frame.

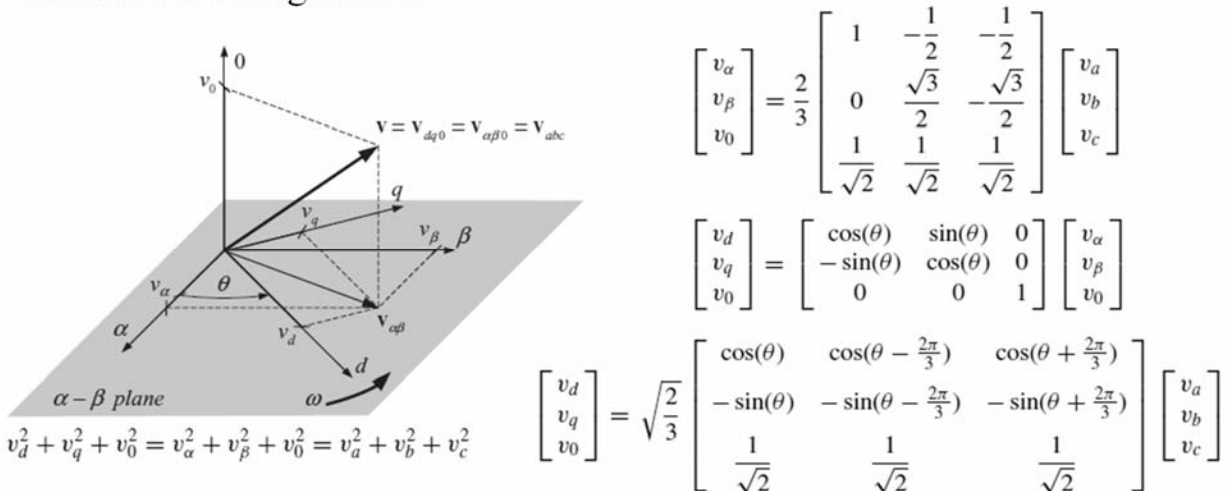

Figures are taken from : R. Teodorescu, M. Liserre, and P. Rodriguez : Grid Converters for Photovoltaic and Wind Power Systems, 2011, John Wiley & Sons, Ltd.

Network unbalances and faults

- Voltage dip can be symmetrical or asymmetrical, phase to ground or phase to phase.

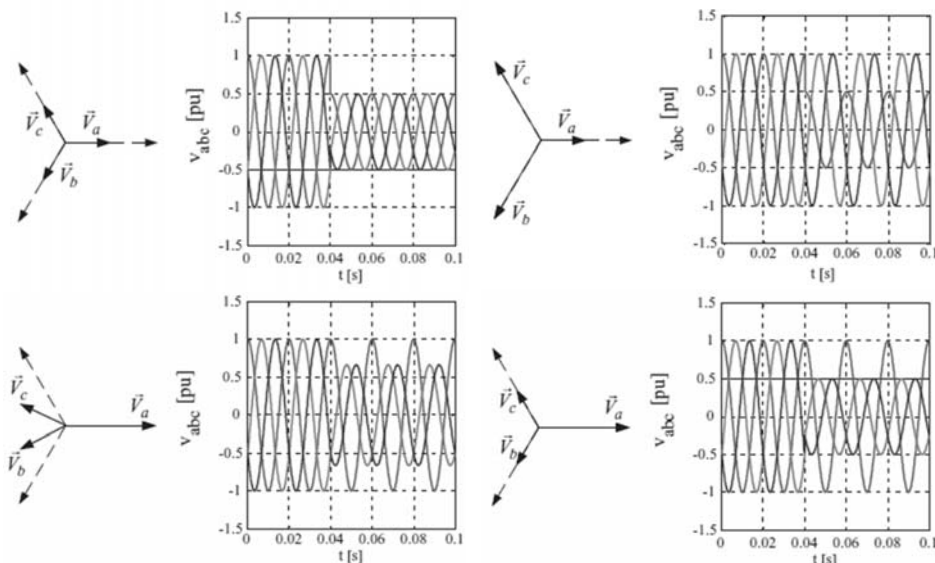

Figures are taken from : R. Teodorescu, M. Liserre, and P. Rodriguez : Grid Converters for Photovoltaic and Wind Power Systems, 2011, John Wiley & Sons, Ltd.

Network unbalances and faults

- When a fault occurs in the three phase network, the circle in the Cartesian plane becomes an ellipse.
- The asymmetry appears as a second harmonic perturbation in the dq rotating synchronous frame which affects synchronisation.

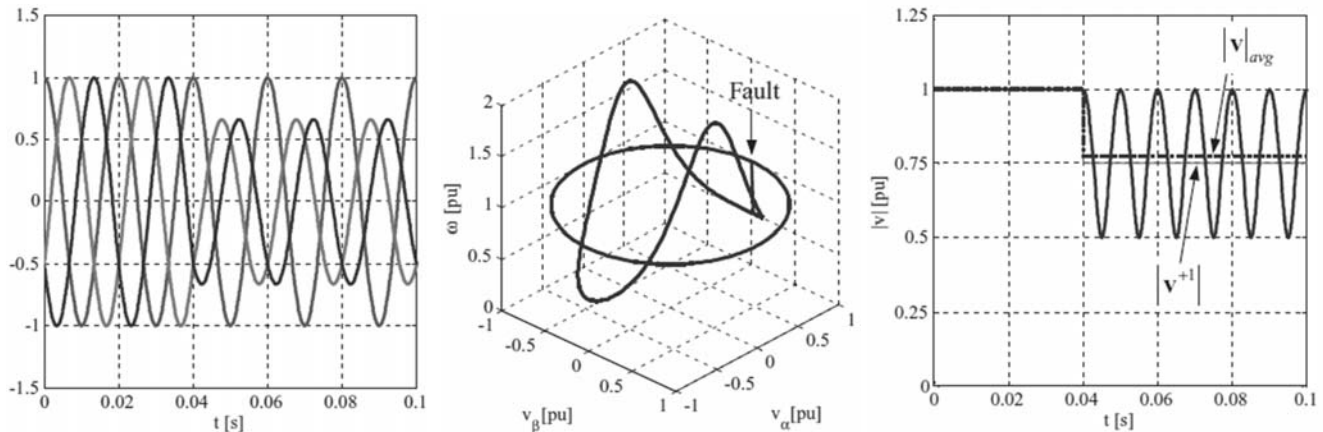

Figures are taken from : R. Teodorescu, M. Liserre, and P. Rodriguez : Grid Converters for Photovoltaic and Wind Power Systems, 2011, John Wiley & Sons, Ltd.

Network unbalances and faults

- The voltage vector \mathbf{V} can be considered as a composition of two vectors, \mathbf{V}^{+1} in the positive sequence rotating reference frame and \mathbf{V}^{-1} in the negative sequence rotating reference frame.
- More generally, \mathbf{V} can be considered as such for each harmonic vector \mathbf{V}^n .

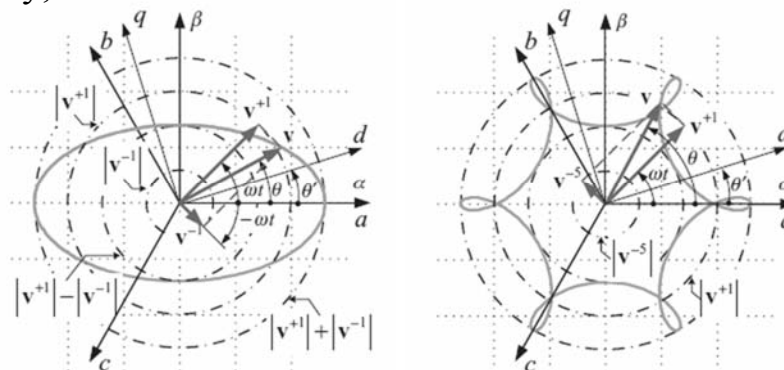

$$|v| = \sqrt{v_\alpha^2 + v_\beta^2} = \sqrt{\frac{3}{2} [(V^{+1})^2 + (V^{-n})^2 + 2V^{+1}V^n \cos((n-1)\omega t)]}$$

Figures are taken from : R. Teodorescu, M. Liserre, and P. Rodriguez : Grid Converters for Photovoltaic and Wind Power Systems, 2011, John Wiley & Sons, Ltd.

Network unbalances and faults

- In any reference frame, the three phase network voltage vectors can be written as a composition of the positive, negative and zero sequence vectors.

$$\mathbf{v}_{abc} = \begin{bmatrix} v_a \\ v_b \\ v_c \end{bmatrix} = \mathbf{v}_{abc}^+ + \mathbf{v}_{abc}^- + \mathbf{v}_{abc}^0$$

$$= V^+ \begin{bmatrix} \cos(\omega t) \\ \cos(\omega t - \frac{2\pi}{3}) \\ \cos(\omega t + \frac{2\pi}{3}) \end{bmatrix} + V^- \begin{bmatrix} \cos(\omega t) \\ \cos(\omega t + \frac{2\pi}{3}) \\ \cos(\omega t - \frac{2\pi}{3}) \end{bmatrix} + V^0 \begin{bmatrix} \cos(\omega t) \\ \cos(\omega t) \\ \cos(\omega t) \end{bmatrix}$$

$$\mathbf{v}_{+-0} = \begin{bmatrix} \bar{v}^+ \\ \bar{v}^- \\ v^0 \end{bmatrix} = \begin{bmatrix} \frac{1}{2}V^+e^{j\omega t} + \frac{1}{2}V^-e^{-j\omega t} \\ \frac{1}{2}V^+e^{-j\omega t} + \frac{1}{2}V^-e^{j\omega t} \\ V^0 \cos(\omega t) \end{bmatrix}$$

$$\mathbf{V}_{+-0(a')} = \begin{bmatrix} \bar{V}_{a'}^+ \\ \bar{V}_{a'}^- \\ \bar{V}_{a'}^0 \end{bmatrix} = \frac{1}{3} \begin{bmatrix} 1 & \alpha & \alpha^2 \\ 1 & \alpha^2 & \alpha \\ 1 & 1 & 1 \end{bmatrix} \begin{bmatrix} \bar{V}_{a'} \\ \bar{V}_{b'} \\ \bar{V}_{c'} \end{bmatrix}$$

where $\alpha = e^{j2\pi/3}$

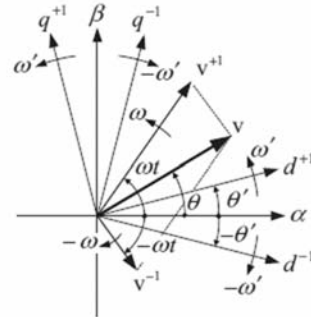

Figures are taken from : R. Teodorescu, M. Liserre, and P. Rodriguez : Grid Converters for Photovoltaic and Wind Power Systems, 2011, John Wiley & Sons, Ltd.

Network strength as seen from PCC

- Point of Common Coupling (PCC) is the link between the network and the power converter, that is also where the network voltage is measured.
- Here the network is modelled as a simple inductive impedance of a value that is affected by its short-circuit power capability (S_{SCC}).
- Typical values: 20 for wind applications, 12 for MV drives.

$$Z_{NET} = \frac{V_{NET}^2}{S_{SCC}}$$

$$R_{NET} = Z_{NET} \cos \phi$$

$$L_{NET} = \frac{Z_{NET} \sin \phi}{2\pi f_{NET}}$$

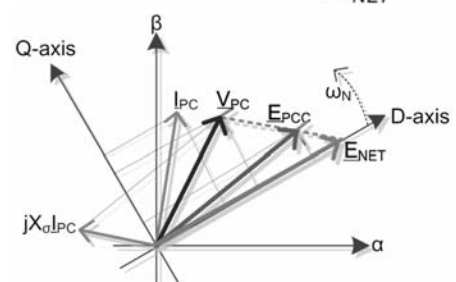
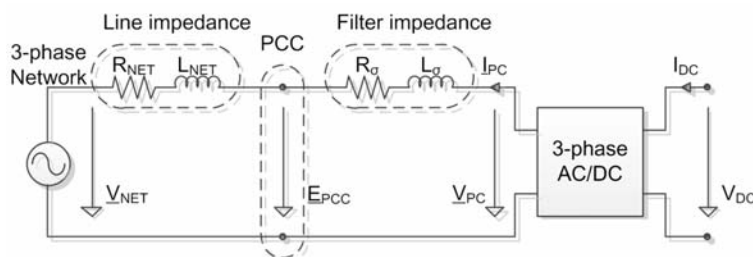

Network strength as seen from PCC

- Under weaker networks, the harmonics generated by the converter appear in the measured network voltage.
- Here is an example with 250Hz switching frequency.

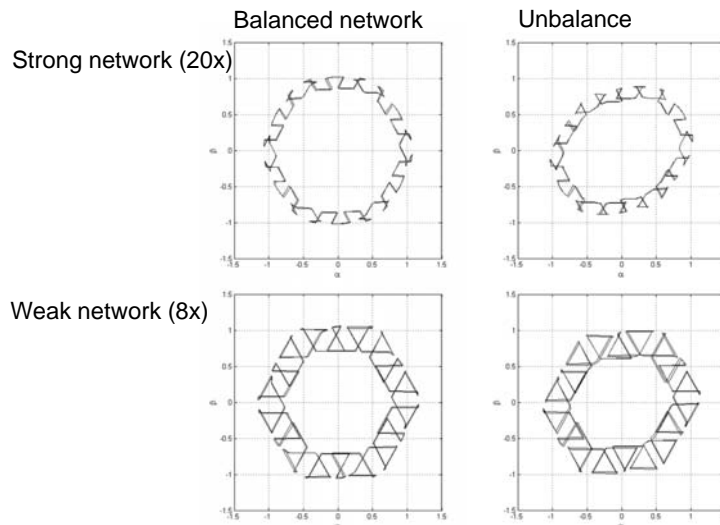

Grid Synchronization

- Most classic way for **network synchronization** is the use of a PLL in the **synchronous reference frame**, other methods exist but will not be covered.
- The identification of the disturbance in the network voltage measurements is done through **positive and negative sequence decoupling**.
- With those two elements, one can accurately **synchronize to weak unbalanced networks**.
- The identification of the disturbance in the network voltage measurement is fed-forward to the classic single frame vector control as first compulsory step for **handling network asymmetries**.
- Among the other methods, one can mention **resonant control principles** which provide the same results in the stationary reference frame.

Synchronous reference frame PLL

- The basic principle of the synchronous reference frame PLL is to maintain the Q component of the network voltage to zero by adjusting the phase of the synchronous reference frame.
- For small phase errors, the voltage error is almost equal to the sinus function of the phase error ($E_Q \approx \sin(\theta_{GRID} - \theta_N)$).
- The resulting angular frequency ω_N from the PI controller is integrated for proving the phase θ_N of the reference plane.
- Additional filtering can be used for harmonic rejection.

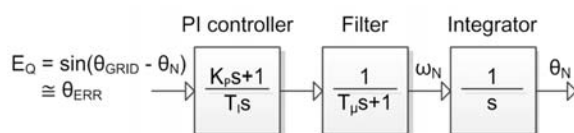
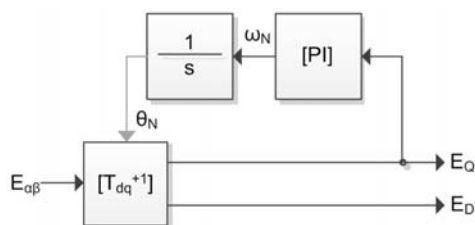

D. Siemaszko, Power Converters and Power Quality II, CAS Power Converters, Baden, 9th May, 2014 Page 17

Synchronous reference frame PLL

- Gain T_N defined to compensate dominant time constant.
- Gain T_I defined to get a given phase margin of 63° (magnitude optimum).

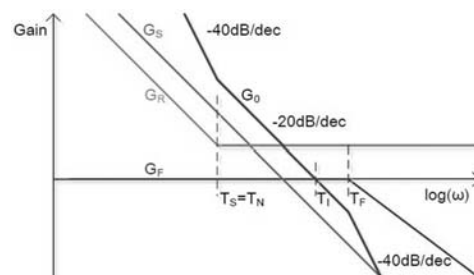

$$G_0(s) = G_R(s)G_M(s)G_S(s)$$

$$G_F(s) = \frac{1}{1 + sT_F}$$

$$G_S(s) = \frac{1}{sT_S}$$

$$G_R(s) = \frac{1 + sT_N}{sT_I}$$

$$T_N = T_S = \frac{1}{\omega_{NET}}$$

$$T_I = 2K_F K_S T_F = 2T_F$$

D. Siemaszko, Power Converters and Power Quality II, CAS Power Converters, Baden, 9th May, 2014 Page 18

Synchronous reference frame PLL

- If well tuned, the PLL controller allows the accurate synchronisation to the network voltage and the rejection of high order harmonics from the network and the converter itself.
- The tuning of the PI controller is done through the Magnitude optimum considering the time constant of the filter.
- For verification purpose, a phase step is applied to the system, one can see that the PLL is back to synchronisation after two periods.
- Phase steps may appear in weak networks when connecting reactive loads.

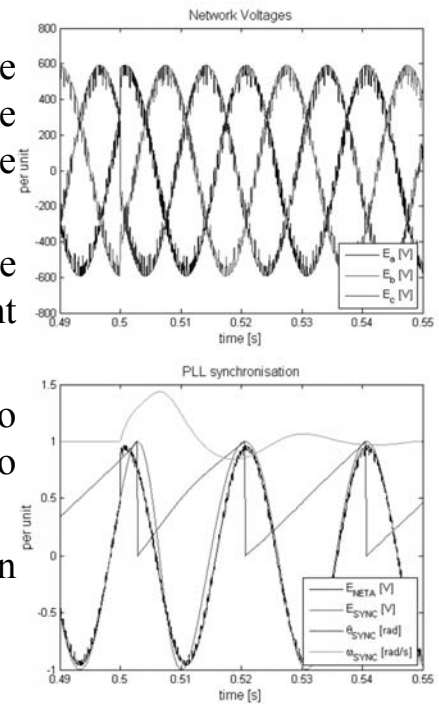

Synchronous reference frame PLL

- Under network voltage unbalance, a strong second harmonic component appears in the Q component, the angular frequency, thus the phase of the synchronous rotating frame.
- One could think of decreasing the filtering time constant, but this would kill dynamics.

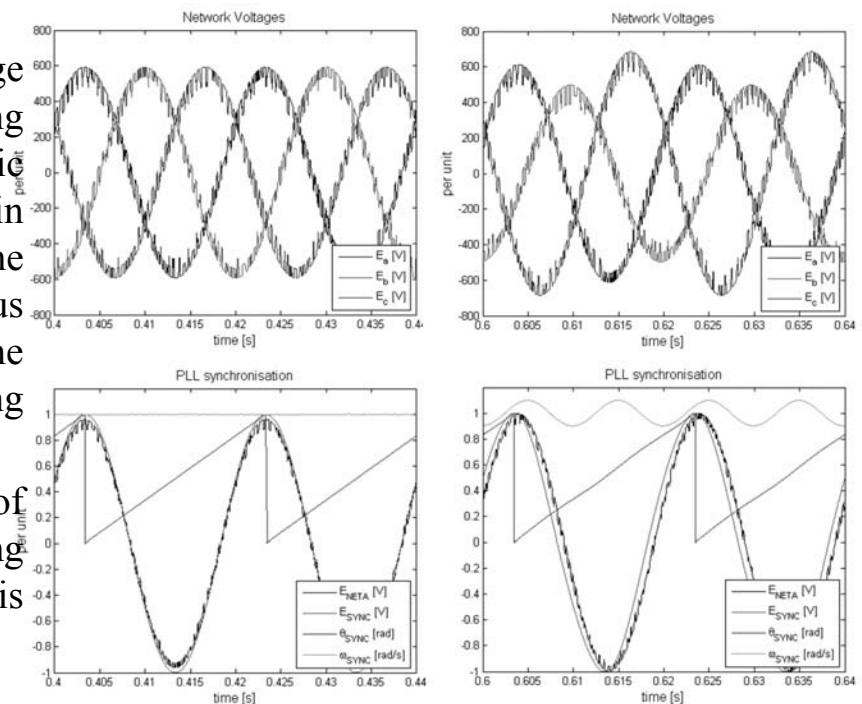

Synchronization to asymmetric networks

- As seen previously, one can consider the voltage phase vector as a combination of a component in the positive sequence, and one in the negative sequence.
- Using park transformation, one can represent the negative sequence phase voltage vector in the positive sequence and vice-versa.

$$\begin{aligned} \mathbf{v}_{\alpha\beta} &= \begin{bmatrix} v_\alpha \\ v_\beta \end{bmatrix} = \mathbf{v}_{\alpha\beta}^{+1} + \mathbf{v}_{\alpha\beta}^{-1} = V^{+1} \begin{bmatrix} \cos(\omega t + \phi^{+1}) \\ \sin(\omega t + \phi^{+1}) \end{bmatrix} + V^{-1} \begin{bmatrix} \cos(-\omega t + \phi^{-1}) \\ \sin(-\omega t + \phi^{-1}) \end{bmatrix} \\ \mathbf{v}_{dq^{+1}} &= \begin{bmatrix} v_{d^{+1}} \\ v_{q^{+1}} \end{bmatrix} = V^{+1} \begin{bmatrix} \cos(\phi^{+1}) \\ \sin(\phi^{+1}) \end{bmatrix} + V^{-1} \begin{bmatrix} \cos(2\omega t) & \sin(2\omega t) \\ -\sin(2\omega t) & \cos(2\omega t) \end{bmatrix} \begin{bmatrix} \cos(\phi^{-1}) \\ \sin(\phi^{-1}) \end{bmatrix} \\ \mathbf{v}_{dq^{-1}} &= \begin{bmatrix} v_{d^{-1}} \\ v_{q^{-1}} \end{bmatrix} = V^{-1} \begin{bmatrix} \cos(\phi^{-1}) \\ \sin(\phi^{-1}) \end{bmatrix} + V^{+1} \begin{bmatrix} \cos(2\omega t) & -\sin(2\omega t) \\ \sin(2\omega t) & \cos(2\omega t) \end{bmatrix} \begin{bmatrix} \cos(\phi^{+1}) \\ \sin(\phi^{+1}) \end{bmatrix} \\ [T_{dq^{+2}}] &= [T_{dq^{-2}}]^T = \begin{bmatrix} \cos(2\omega t) & \sin(2\omega t) \\ -\sin(2\omega t) & \cos(2\omega t) \end{bmatrix} \end{aligned}$$

Figures are taken from : R. Teodorescu, M. Liserre, and P. Rodriguez : Grid Converters for Photovoltaic and Wind Power Systems, 2011, John Wiley & Sons, Ltd.

Synchronization to asymmetric networks

- The transformation of the voltage phase vector from the stationary reference frame to one of the two rotating reference frames, will always include the components from the complementary rotating frame.
- The decoupled components are obtained by subtracting the phase vector coming from the complementary rotating frame after filtering.
- As a result, the network voltage is transformed into four DC components.
- The same can be applied for higher order harmonics.

$$\begin{aligned} \bar{\mathbf{v}}_{dq^{+1}}^* &= \begin{bmatrix} \bar{v}_{d^{+1}}^* \\ \bar{v}_{q^{+1}}^* \end{bmatrix} = [F] \left\{ \mathbf{v}_{dq^{+1}} - [T_{dq^{+2}}] \bar{\mathbf{v}}_{dq^{-1}}^* \right\} \\ \bar{\mathbf{v}}_{dq^{-1}}^* &= \begin{bmatrix} \bar{v}_{d^{-1}}^* \\ \bar{v}_{q^{-1}}^* \end{bmatrix} = [F] \left\{ \mathbf{v}_{dq^{-1}} - [T_{dq^{-2}}] \bar{\mathbf{v}}_{dq^{+1}}^* \right\} \end{aligned}$$

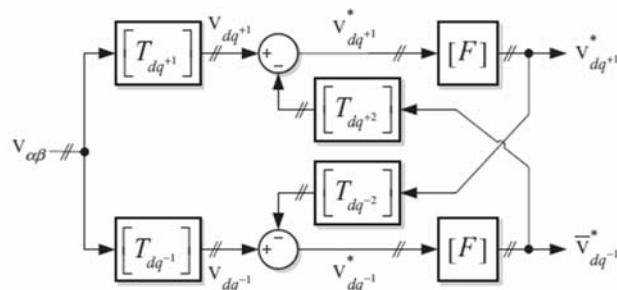

Figures are taken from : R. Teodorescu, M. Liserre, and P. Rodriguez : Grid Converters for Photovoltaic and Wind Power Systems, 2011, John Wiley & Sons, Ltd.

Synchronization to asymmetric networks

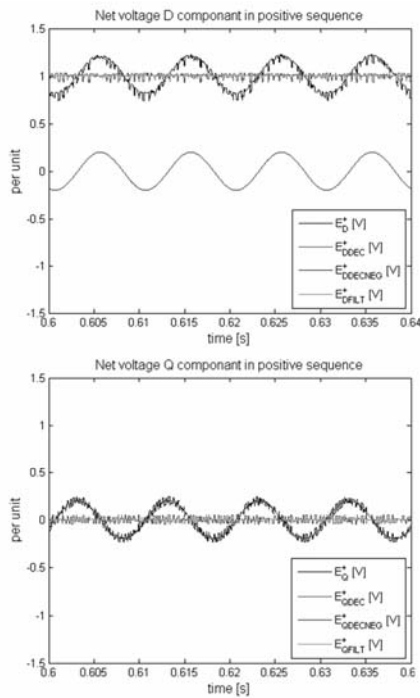

The decoupling process illustrated - Principle

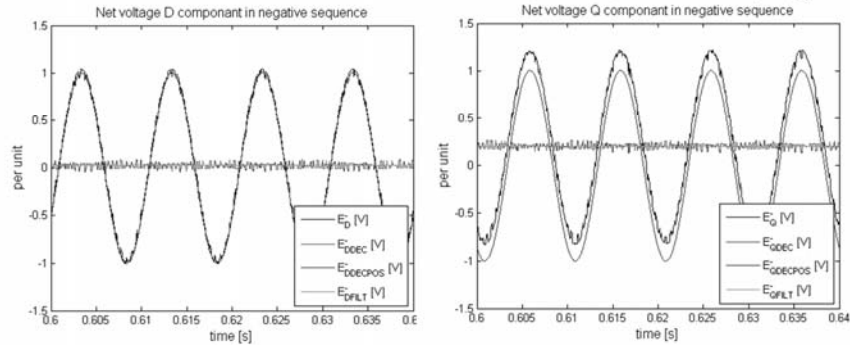
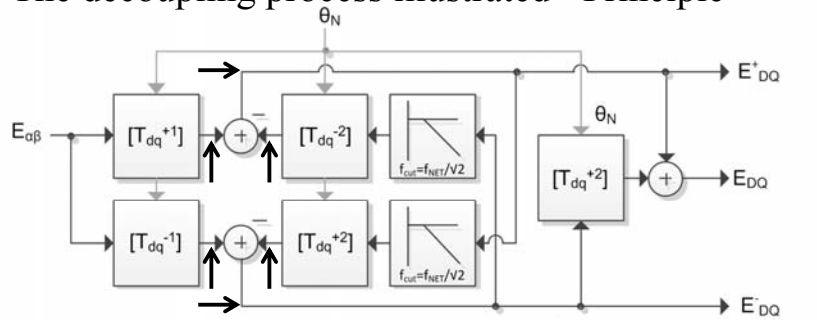

Synchronization to asymmetric networks

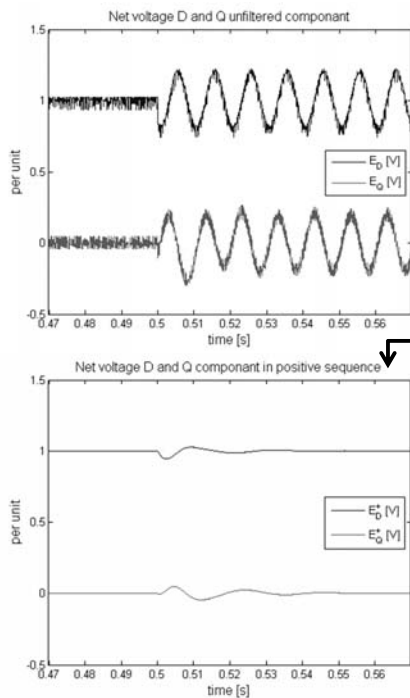

The decoupling process illustrated - Dynamics

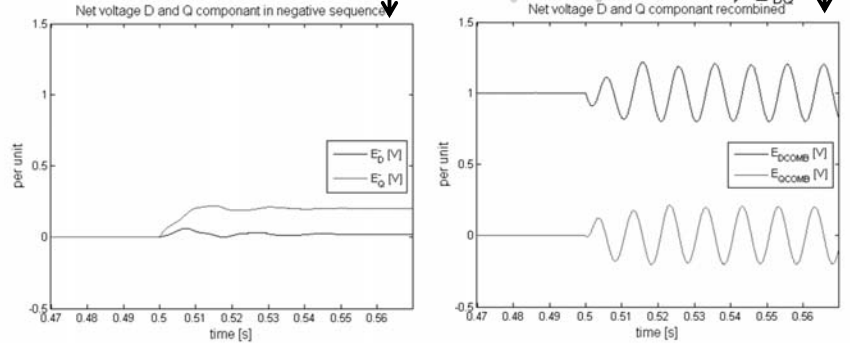
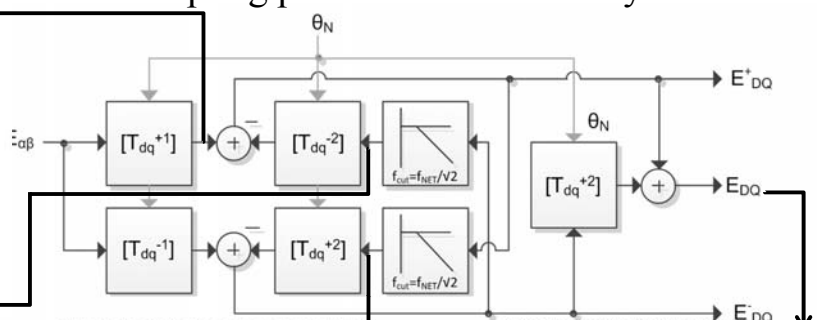

Synchronization to asymmetric networks

- Now the two voltage phase vectors are perfectly decoupled in each of the two reference frames, one can be sure that the Q component in the positive reference frame is free of the second harmonic when unbalance occur.
- The PLL can use this value as an input, this result in a new PLL structure, called Double Decoupled Synchronous Reference Frame PLL (DDSRF).

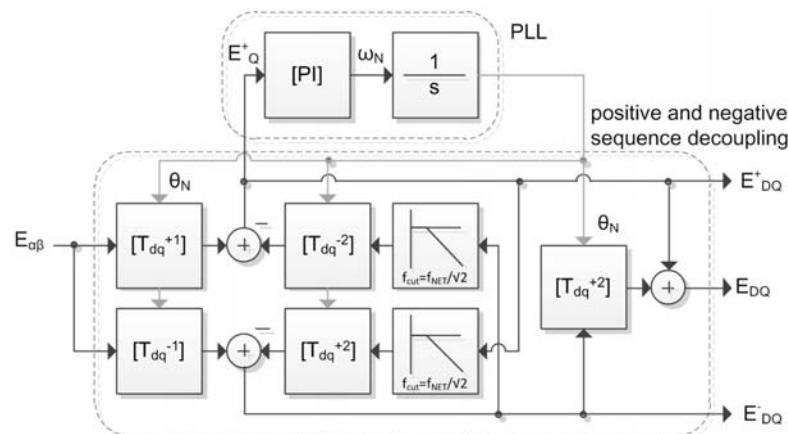

Synchronization to asymmetric networks

- The PLL is not anymore affected by the second harmonic appearing when the network voltages are unbalanced.
- The same can be applied for rejecting higher order harmonics, but a filter can also be used without affecting the dynamics of the PLL controller.
- During unbalance a phase shift appears between the voltage phase vector in the positive sequence and the phase vector.

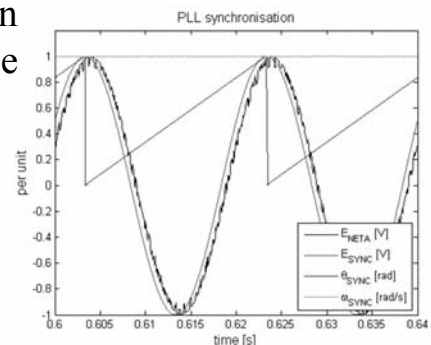
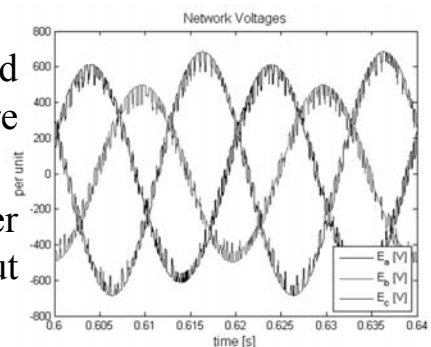

Synchronization to asymmetric networks

- When the voltage components are filtered (for voltage feed forward, harmonic rejection, etc...) it produces a phase shift in the ellipsoidal representation of an unbalanced network.
- When the voltage components are decoupled and separately filtered, their recombination allows to keep the phase of the ellipse in the $\alpha\beta$ plane and the oscillation in the DQ plane.

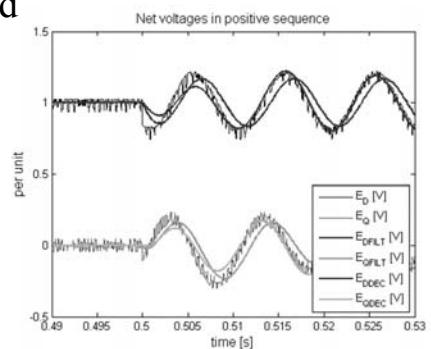
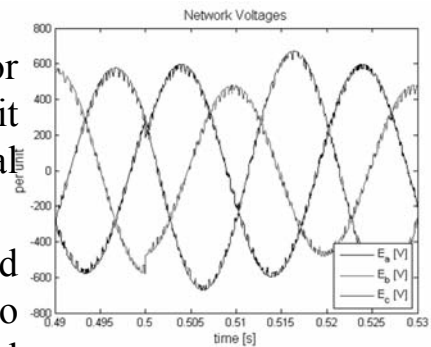
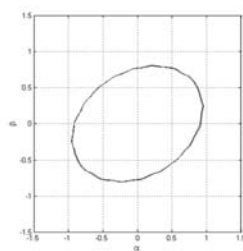
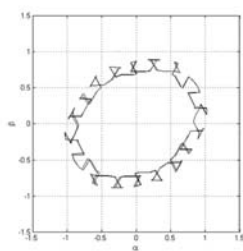
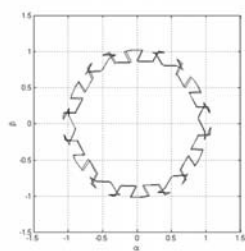

Synchronisation to asymmetric networks

- When the network is weak, the harmonics coming from the converter or the network itself are much stronger, here the ratio between network and filter impedance is only 5 (against 50 used previously).
- The filtering used in the PLL controller allows their full rejection.
- Phase step response shows that synchronisation is ensured with strong dynamics.

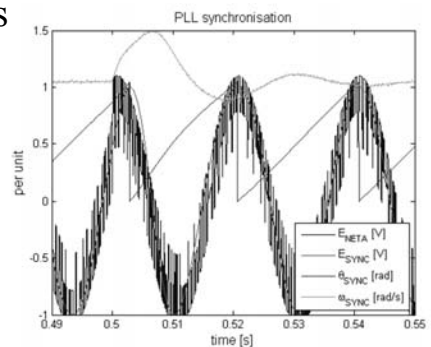
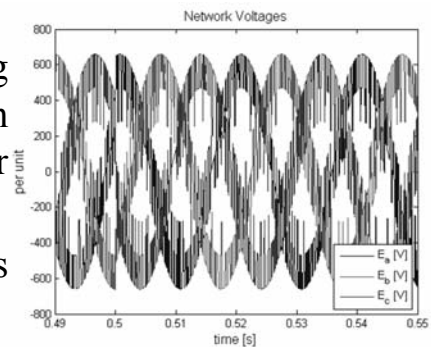

Synchronisation to asymmetric networks

- Under unbalance, the separate filtering of the measured voltage in the two rotating reference frames allows the full rejection of all harmonics and an accurate description of the second harmonic coming from the network unbalance.

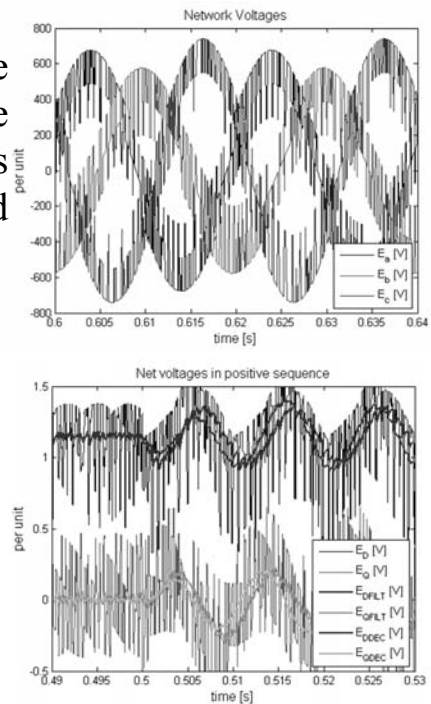

Power Converters and Asymmetric Grids

- Since **dynamics** of the current controller in the DQ reference frame are directly related to the switching frequency, one may be limited for damping the second harmonic component due to voltage unbalance.
- Same as for the voltages, the **converter currents** are considered in the two synchronous rotating references frames, the direct and the indirect.
- The **four current components** are controlled separately by a **double frame controller**, one per synchronous frame working as a mirror.
- One can control each of the current component, **force current symmetry** with voltage asymmetries or **force current asymmetry for compensation**.

Classic current control

- Classic current control is vector control in the synchronous rotating reference frame (or DQ frame). The current target is reached by applying the correct voltage vector on the converter side, using the voltage drop across the filter impedance for generating a current.

$$\begin{cases} \underline{U}_S = \underline{U}e^{j\omega t} \\ \underline{I}_S = \underline{I}e^{j\omega t} \end{cases}$$

$$\underline{U} = R_\sigma \underline{I} + L_\sigma \frac{d(\underline{I})}{dt}$$

$$\underline{U}_S = R_\sigma \underline{I}e^{j\omega t} + L_\sigma \frac{d(\underline{I}e^{j\omega t})}{dt}$$

$$= R_\sigma \underline{I}_S + L_\sigma \frac{d\underline{I}_S}{dt} + j\omega L_\sigma \underline{I}_S$$

$$= [R_\sigma + (s + j\omega)L_\sigma] \underline{I}_S$$

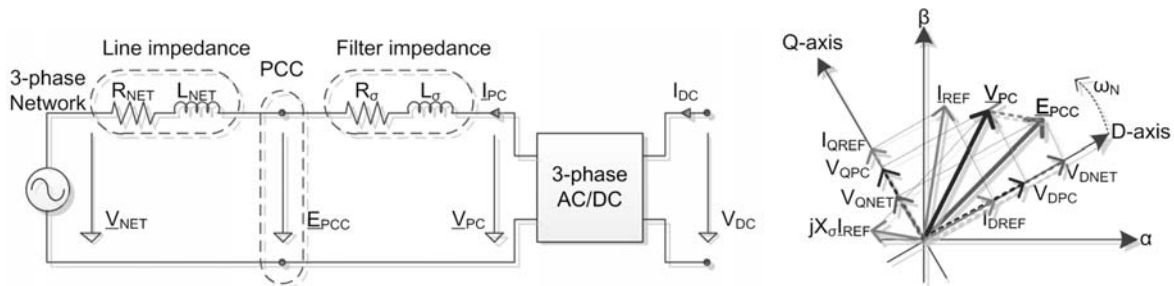

Classic current control

- The control loop contains the system $G_S(s)$, the modulator $G_M(s)$ and the controller itself $G_R(s)$.
- The sampling of the digital controller is synchronised with the PWM triangle generator, synchronised with the PLL.
- Correct sampling for the measurement of the signals allows to avoid the used of measurement filters which affect the bandwidth.
- The bandwidth of the control loop is defined by the modulator's time constant.

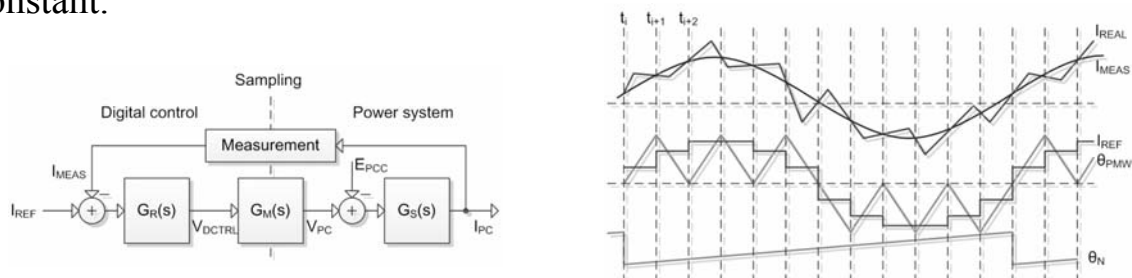

Classic current control

- Gain T_N defined to compensate dominant time constant.
- Gain T_I defined to get a given phase margin of 63° (magnitude optimum).

$$G_S(s) = \frac{1}{1 + (s + j\omega) \frac{L_\sigma}{R_\sigma}}$$

$$G_M(s) = \frac{K_M}{1 + T_M s}$$

$$T_N = \frac{L_\sigma}{R_\sigma}$$

$$T_I = 2K_M \frac{T_M}{R_\sigma}$$

$$G_R(s) = \frac{1 + (s + j\omega)T_N}{sT_I} = \frac{1 + sT_N}{sT_I} + \frac{j\omega T_N}{sT_I}$$

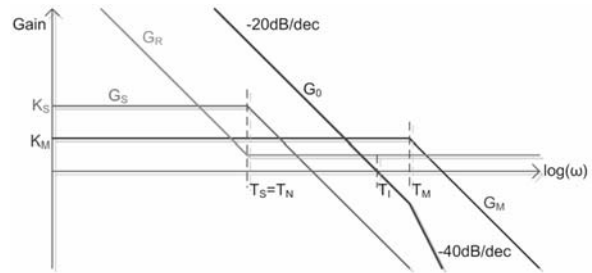

$$\begin{aligned} G_0(s) &= G_R(s)G_M(s)G_S(s) \\ &= \frac{1 + (s + j\omega)T_N}{sT_I} \frac{K_M}{1 + T_M s} \frac{1}{1 + (s + j\omega) \frac{L_\sigma}{R_\sigma}} \\ &= \frac{1}{sT_I} \frac{K_M}{1 + T_M s} \frac{1}{R_\sigma} \\ &= \frac{1}{s^2 T_M} \frac{1}{1 + T_M s} \end{aligned}$$

$$\begin{cases} V_D = \frac{1 + sT_N}{sT_I} I_{Derr} + \frac{\omega T_N}{sT_I} I_{Qerr} \\ V_Q = \frac{1 + sT_N}{sT_I} I_{Qerr} + \frac{\omega T_N}{sT_I} I_{Derr} \end{cases}$$

Classic current control

- Current references are given by either a DC-link voltage controller, or a network voltage controller when the converter is used as a generator.
- In this case of this study, the current references are given by the user.
- The PI controller in the DQ rotating frame is used, the cross coupling should be implemented as integral parts as well as in the multivariable controller.

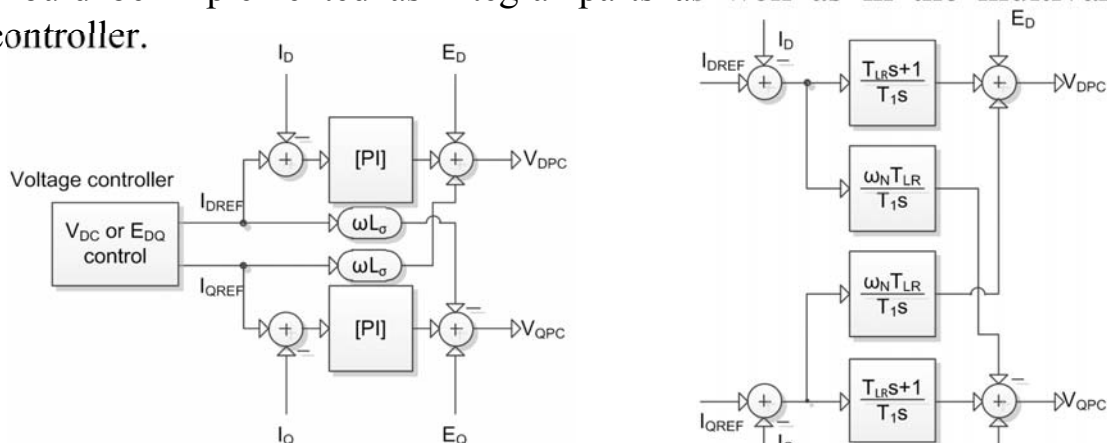

Current control with unbalanced phase voltages

- Simple operation is first tested with quite strong network (50x) and 750Hz switching frequency.
- When network unbalance occur, one sees a step in the negative sequence of the voltage, the positive sequence remains here unchanged.

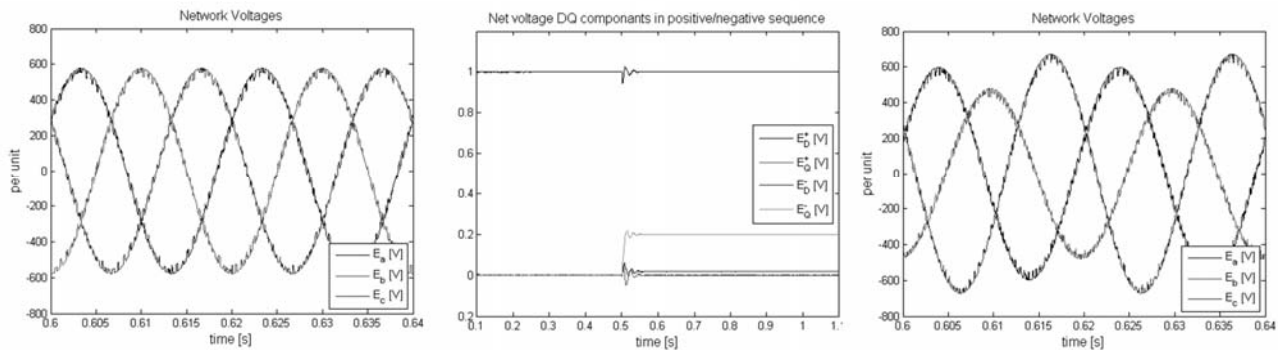

Current control with unbalanced phase voltages

- The control of each current component is allowed by correct decoupling and accuracy in the control parameters tuning through magnitude optimum criterion and Bühler's methods.
- One can see the accuracy of the integral decoupling with the very limited impact of the variation of one component on the other.
- Since the controller is operated with quite a high switching frequency, the dynamics of the controller are fast enough to somehow maintain the symmetry in the current during a voltage phase dip.

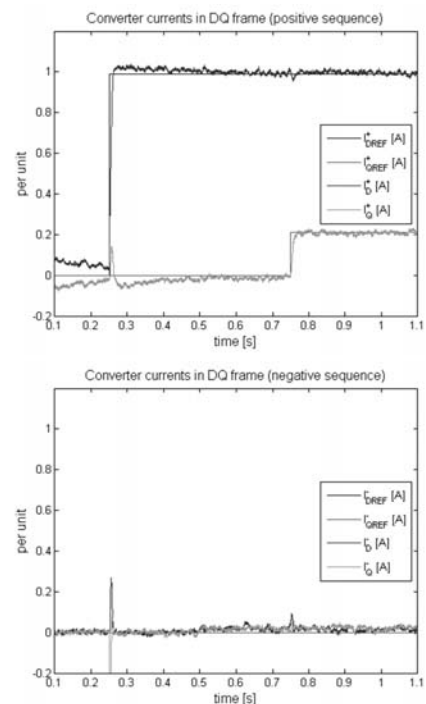

Current control with unbalanced phase voltages

- With lower switching frequency (450Hz) and lower network strength (20x) the impact on the network harmonics is more visible and seems stronger.
- The dynamics of the PLL do not seem affected.

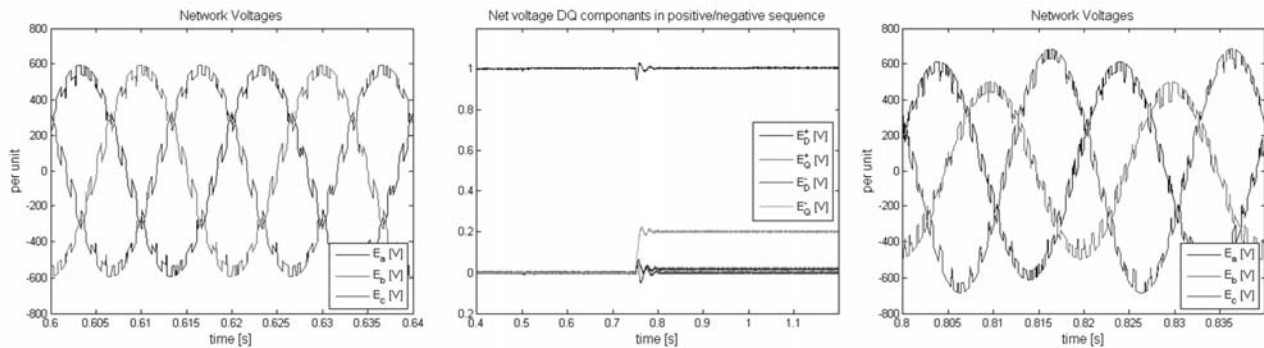

Current control with unbalanced phase voltages

- Lower switching frequencies impact current ripple only not the control of the current itself.
- Lower switching frequencies also mean lower control dynamics, therefore, the voltage unbalance impacts the current unbalance, which are in the same direction as the voltage as seen here in the negative sequence of the currents.

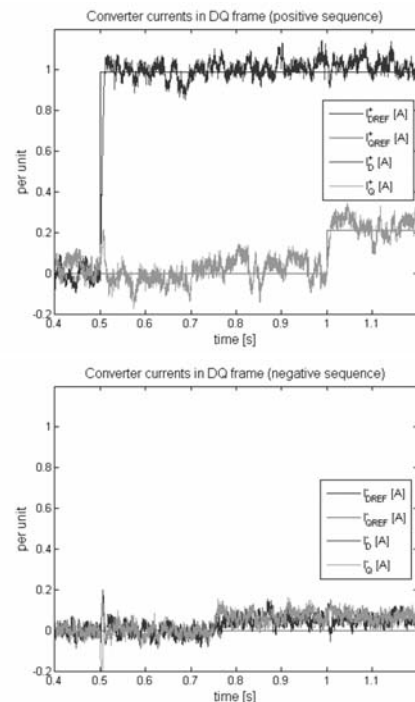

Current control with unbalanced phase voltages

- Network voltage unbalance doesn't affect the currents as long as current control dynamics are fast enough to fully compensate the second harmonic.
- For high power applications, especially grid connected converters, switching frequencies tend to be low in respect of switching losses.
- The current unbalance is not an issue when DC-link and network are ideal voltage sources.
- When facing voltage unbalance and current symmetry, instantaneous power can only be oscillatory, which affects the current control when having a real capacitor.
- With the analogy to the voltage decoupling in the rotating frames, the same could be applied in the current for allowing full control of the current negative sequence.

Double frame control for phase currents

- The philosophy behind the double frame control is the need for controlling the current unbalance by controlling not two current component but four, two in each synchronous rotating reference frames.
- Exactly as for the voltages, the currents are transformed in the two rotating frames, then decoupled from each other's DC component.
- The double frame control structure is a perfect mirror between two classic single DQ frame controller, each of them requiring two current references most likely coming from a voltage controller.
- The four current references can be computed with a function containing several targets regarding current symmetry or power compensation.
- If measured current are filtered, the current reference shall also contain the same filtering, in order to achieve optimum parameters with the magnitude optimum criterion.

Double frame control for phase currents

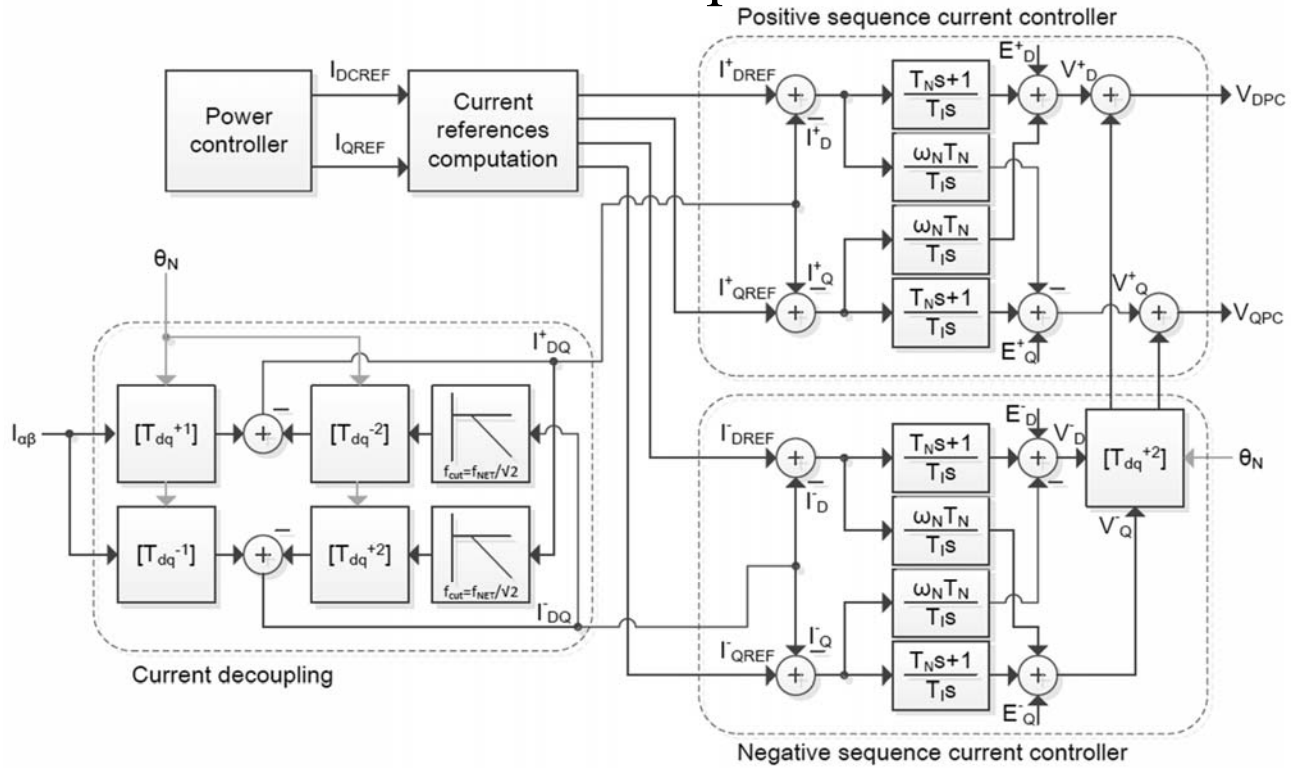

Double frame control for phase currents

- The double frame structure is tested with the same control parameters as for the single frame multivariable control.
- Voltage unbalance is set as in the following figure, by adding a negative sequence component, for simulating a phase dip in the network.
- Each of the four current references are set separately for assessing the effect on the effective currents, under network balance or unbalance.

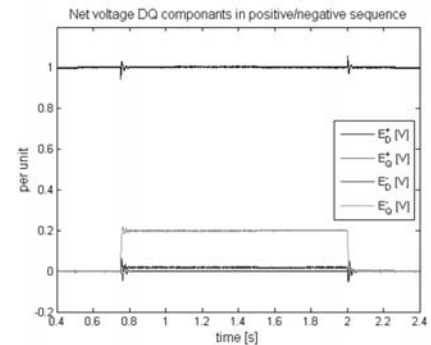

Double frame control for phase currents

- Each of the four current component can be separately controlled.
- One can force current symmetry or dissymmetry.
- The following example is set with 750Hz switching frequency and network strength of 50.

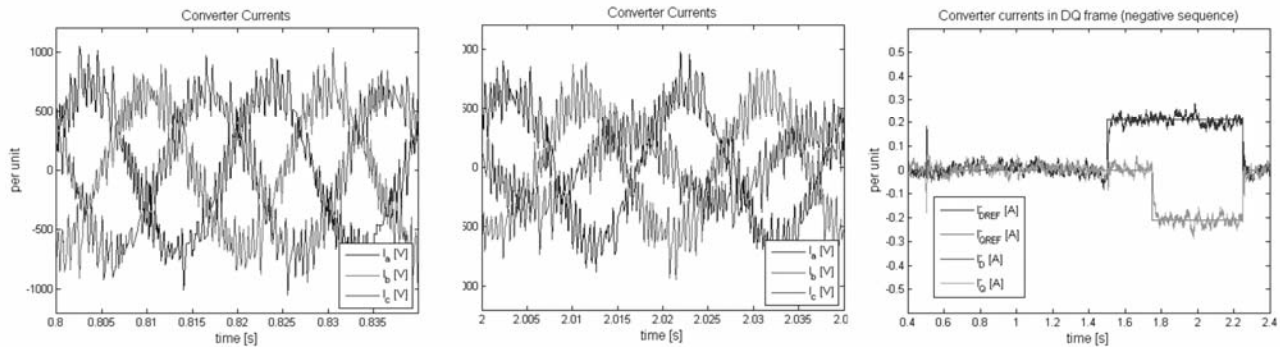

Double frame control for phase currents

- The ripple in the currents is not influenced by network strength.
- Same as before, all four components can be freely controlled without any coupling effect.
- Network strength is here set to 20 and switching frequency is 450Hz.

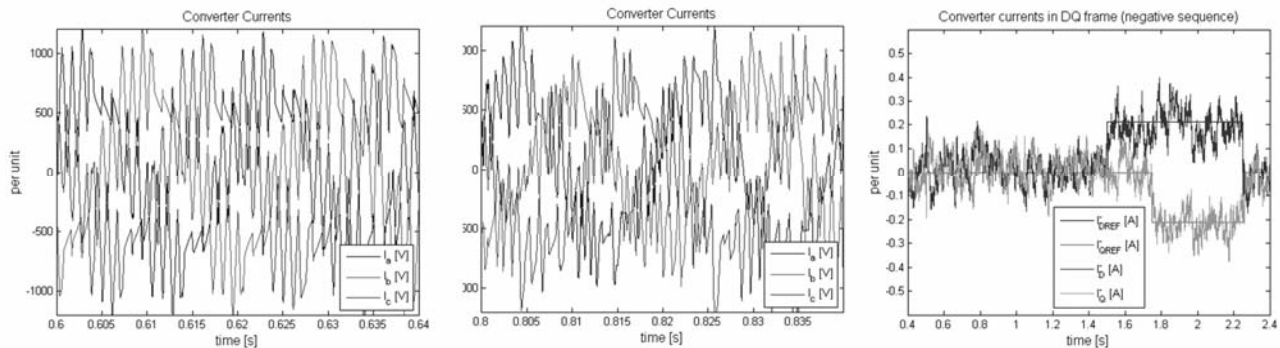

Double frame control for phase currents

- Closer to reality, the DC link is not ideal, merely a capacitor bank dimensioned with the following principle: oversizing is very expensive, so under sizing is more likely to happen in industry.
- Two configurations of the grid voltage source inverter are considered:

- Converter controls the voltage on the network side.

- Converter controls the voltage on the DC side.

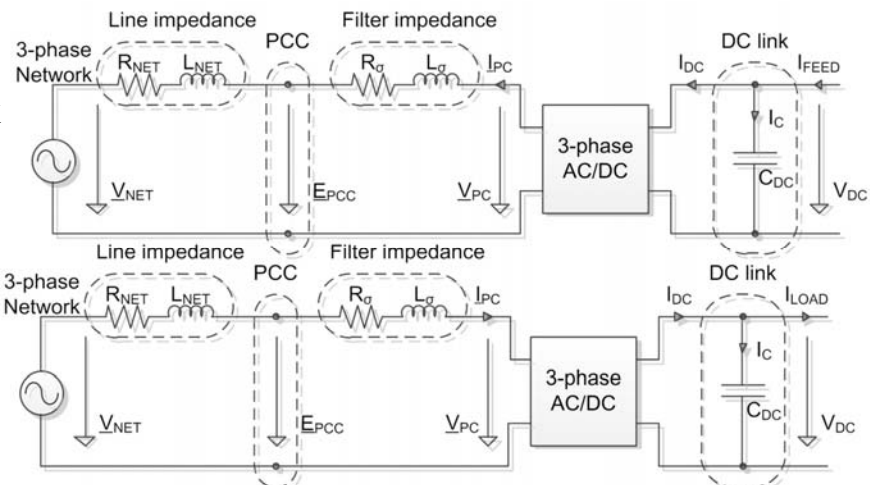

D. Siemaszko, Power Converters and Power Quality II, CAS Power Converters, Baden, 9th May, 2014

Page 45

Double frame control for phase currents

- When voltage unbalance occur, keeping the currents symmetrical has an impact on the instantaneous power.

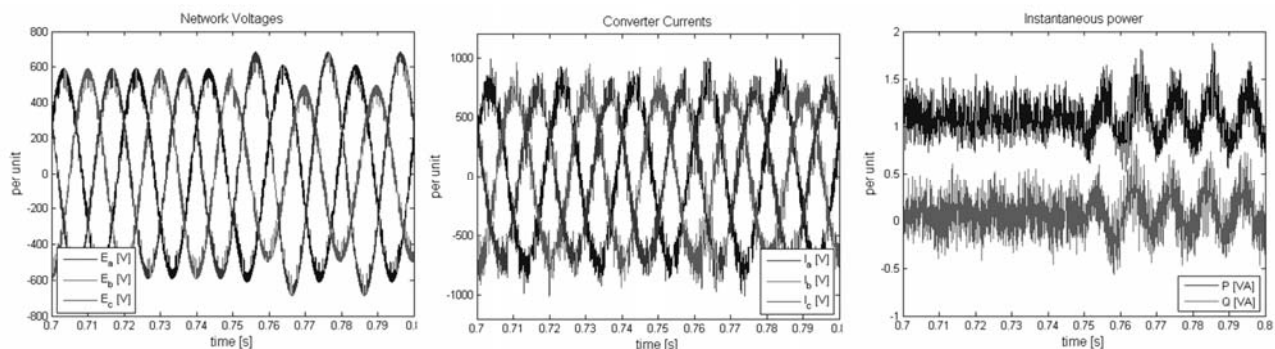

- When the instantaneous power has a second harmonics due to network unbalance, the DC-link voltage will also contain the second harmonic.

$$\hat{V}_{dcripple} = \frac{\hat{P}_{ripple}}{2C_{eq}\omega V_{dcref}}$$

Figure taken from : A. Yazdani, R. Iravani, "A unified dynamic model and control for the voltage-sourced converter under unbalanced grid conditions," Power Delivery, IEEE Transactions on , vol.21, no.3, pp.1620-1629, July 2006.

D. Siemaszko, Power Converters and Power Quality II, CAS Power Converters, Baden, 9th May, 2014

Page 46

Double frame control for phase currents

- When facing asymmetric disturbances in the phase voltages, adequate control of currents may compensate the 2nd harmonic component in the instantaneous active power, not the reactive.
- Method limited by what allow the semiconductor ratings.

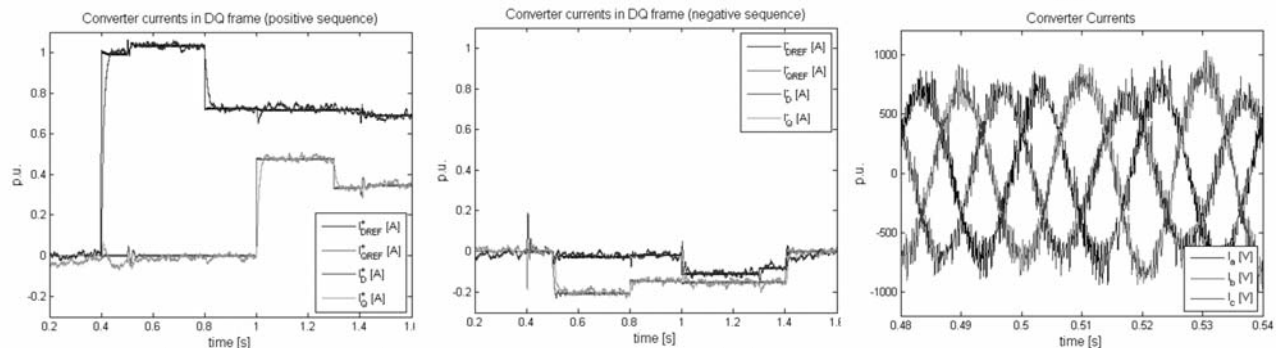

Figure taken from : Siemaszko, D.; Rufer, A.; , " Power Compensation Approach and Double Frame Control for Grid Connected Converters", EPE 2013 : 15th European Conference on Power Electronics and Applications, Lille, France, 3-5 September 2013.

Contact

Dr. Daniel Siemaszko

daniel.siemaszko@a3.epfl.ch

