



AGH UNIVERSITY OF SCIENCE  
AND TECHNOLOGY



# FCAL: Today and Future

from detector perspective

**Marek Idzik** AGH-UST

FCAL Collaboration

AGH-UST Cracow, ANL Argonne, CERN Geneva, DESY Zeuthen, IFIN-HH Bukharest, INPPAN Cracow, ISS Bukharest, LAL Orsay, JINR Dubna, NCPHEP Minsk, Pontifica Universidad Catholica Santiago de Chile, SLAC Stanford, Tel Aviv University, Tohoku University Sendai, University of Colorado Boulder, UC California Santa Cruz, Vinca Belgrade



CLIC Detector and Physics Collaboration meeting 2013, 1-2 October 2013 CERN

# Outline

- Introduction
- Current Status
  - Sub-detectors
  - Test-beam results
- FCAL R&D and future works
  - Near future: Mechanical frame & test-beam setup
  - Sensor R&D
  - Readout R&D
  - Laser alignment
- Summary & Future plans

# Introduction

## FCAL Mission

- Design of the very forward region of detectors at future linear collider
- Concept for precise and fast measurement of the luminosity
- Development, prototyping and test of the detectors
- Verification of Monte Carlo estimates of the detector performance
- Ensure that critical R&D is addressed in a timely manner

### Challenges:

- High precision luminometer
- High occupancy
- High radiation tolerance
- Fast readout electronics

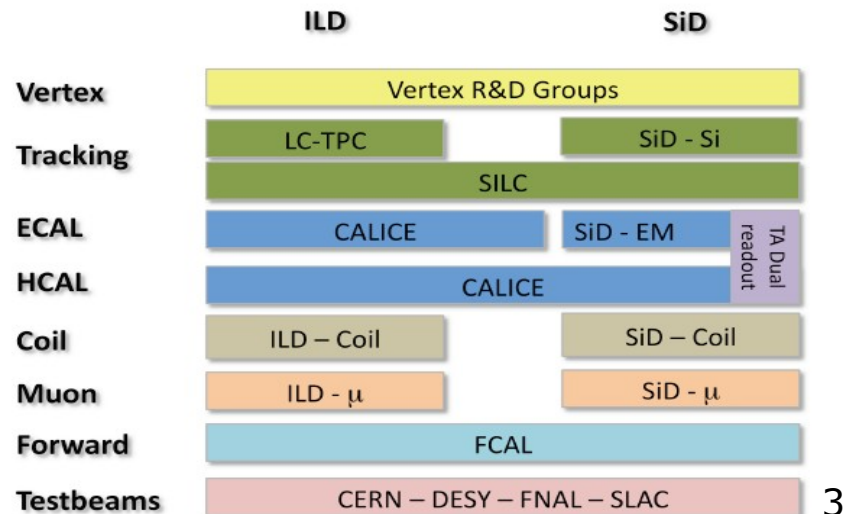

## ILD concept for ILC

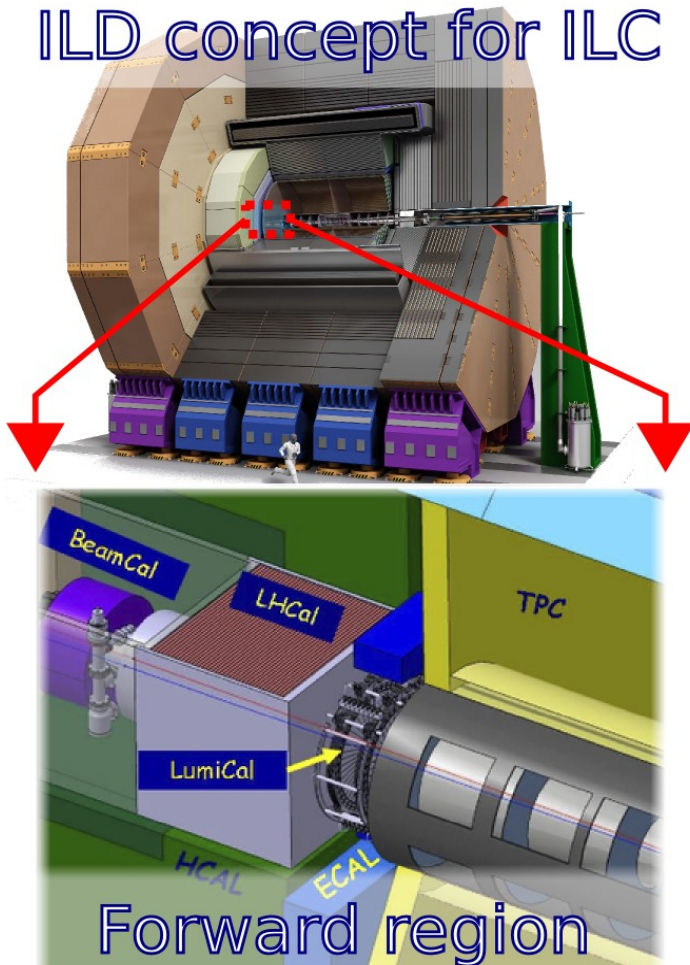

## BeamCal (+Pair Monitor)

- Fast luminosity estimate (bunch-by-bunch at ILC)
- Beam parameter estimation
- Fast feedback to the machine
- Hermeticity & Low angle electron tagging

## LumiCal

- Precise measurement of luminosity
- $10^{-3}$  at ILC,  $10^{-2}$  at CLIC
- Hermeticity
- Low angle physics

# FCAL Detector R&D Status

## Prototype sub-detectors

- Readout module (LumiCal) for 32 channels
- LumiCal sensors
- BeamCal sensors

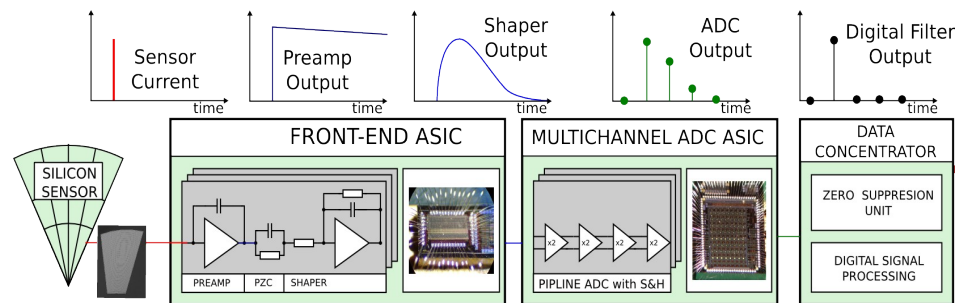

***Few successful test-beams were run in recent years***

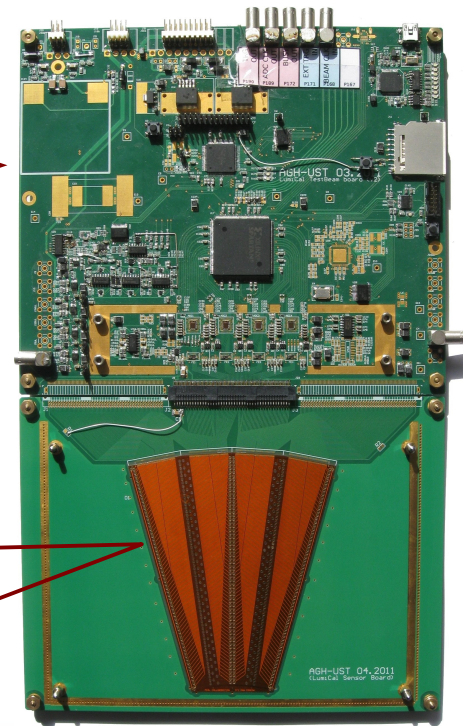
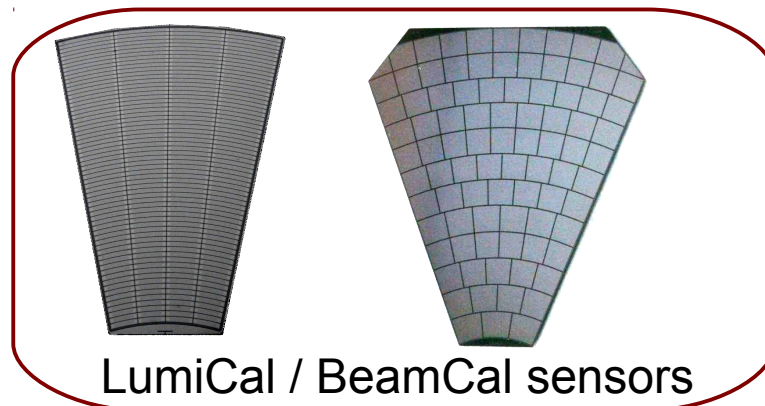

# Beam-test result examples

## S/N, noise, shower profile

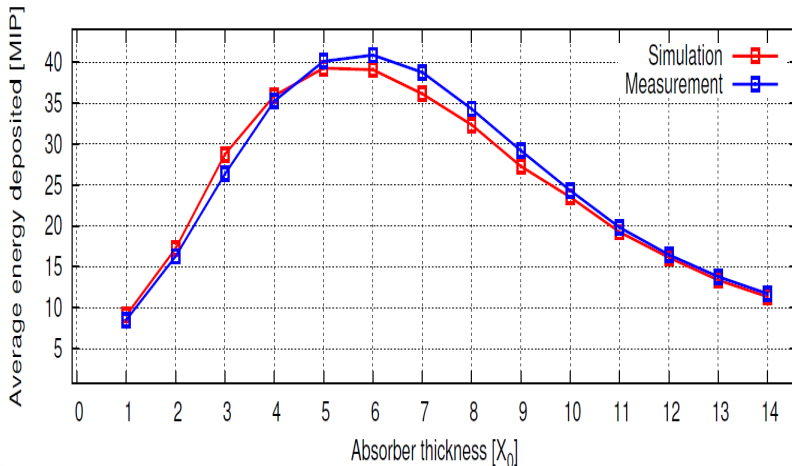
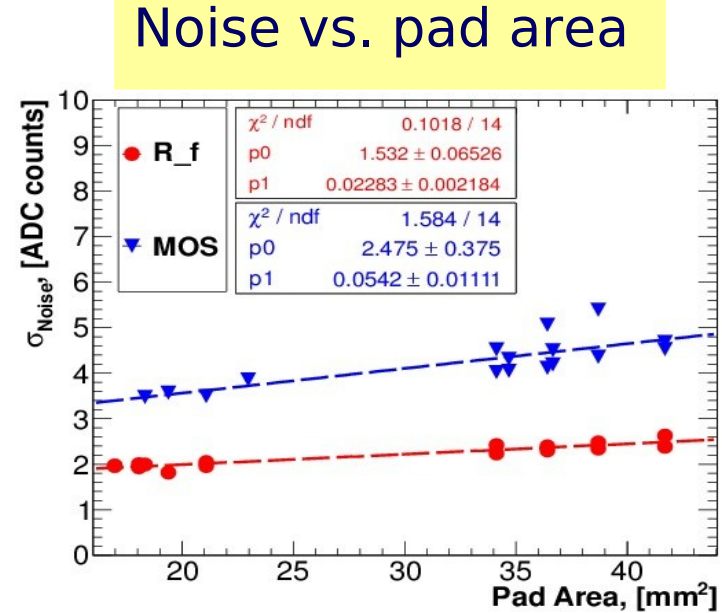
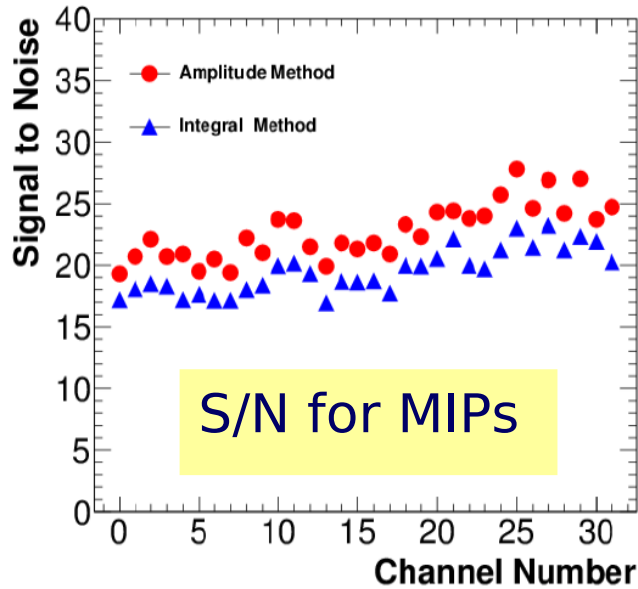

Shower profile measurements with n X0 tungsten blocks in front of the sensors



# Beam-test result examples

## Position reconstruction

Impact point reconstruction using the beam telescope For LumiCal sensor

Impact point reconstruction using the beam telescope For BeamCal sensor

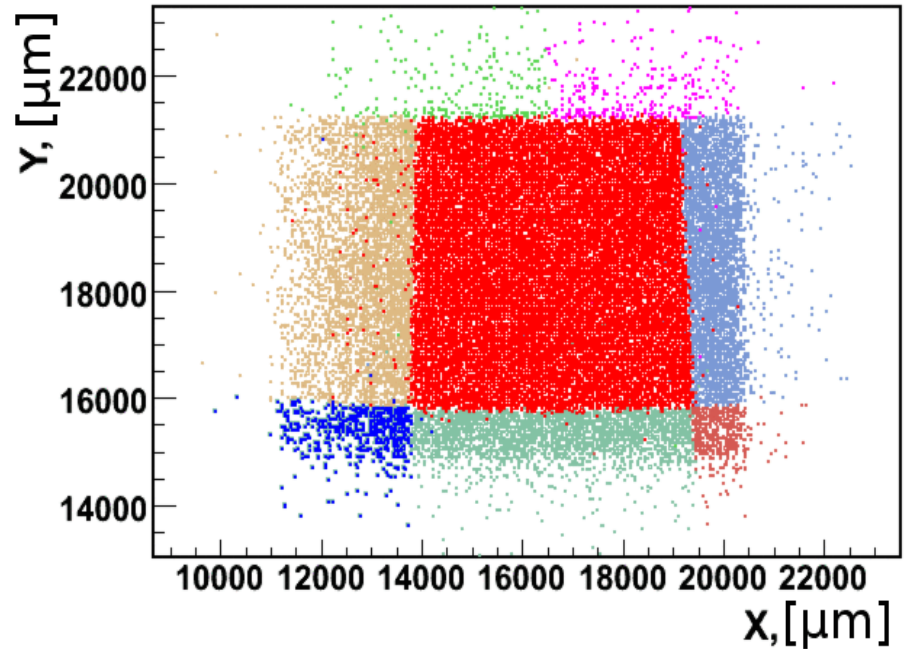
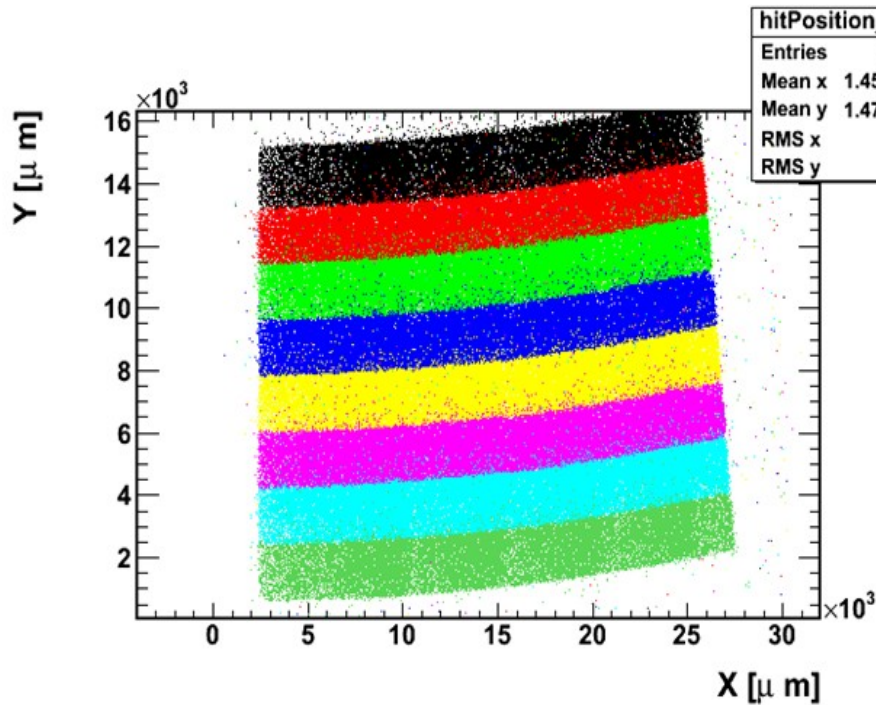

## Current status FCAL Deliveries (so far)

- Designs of the very forward region for ILC and CLIC detectors
- Monte Carlo estimates of the expected performance of a Luminometer for precise luminosity measurement
- Feasibility of fast luminosity measurement, beam parameter determination and electron tagging with BeamCal and Pair Monitor
- Successful development of sensors and dedicated ASICs
- Successful prototyping of major detector components and validation on test-beams
- Unique contributions to the ILC RDR, the CLIC CDR, the ILC TDR and to the detector concepts ILD and SiD

**The review by 'European Detector R&D' committee in June 2013 stated that: *"The linear collider community and the funding agencies should strongly support this activity as it is a key issue for precision measurements"***



# FCAL R&D at CERN – Near future

## Flexible mechanical frame with tungsten plates

### AIDA milestone

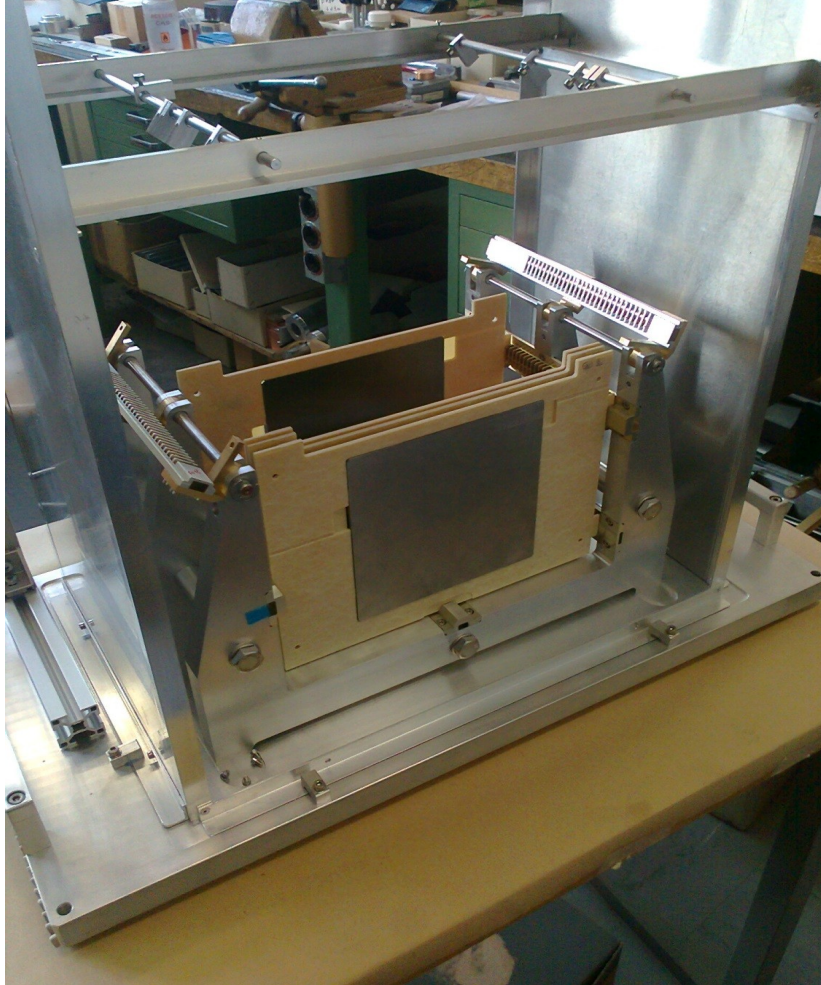

- Mechanical frame has been built
- 11 tungsten plates obtained from Plansee and MGSanders (AGH-UST, CERN, INP PAN)
  - Plansee plates much better and almost within specifications
- Works ongoing on integration and cabling of prototype detectors

# FCAL activities for testbeams – Near future

## Mechanical frame with sub-detector modules

- FCAL detector components:
  - Recently we have assembled more LumiCal readout boards so there are 4 completed (which are also used for BeamCal readout)
  - LumiCal: 40 sensor tiles produced, 2 boards ready
  - BeamCal: almost 30 sensor tiles produced, 2 boards ready
- Previous test-beams done with single detector modules and row (not well flattened, composition not known precisely) tungsten material
- For future test-beam we plan to use the flexible mechanical frame with tungsten plates and all detector modules

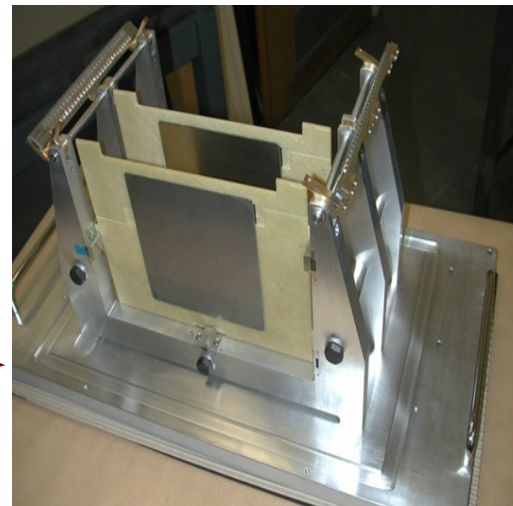
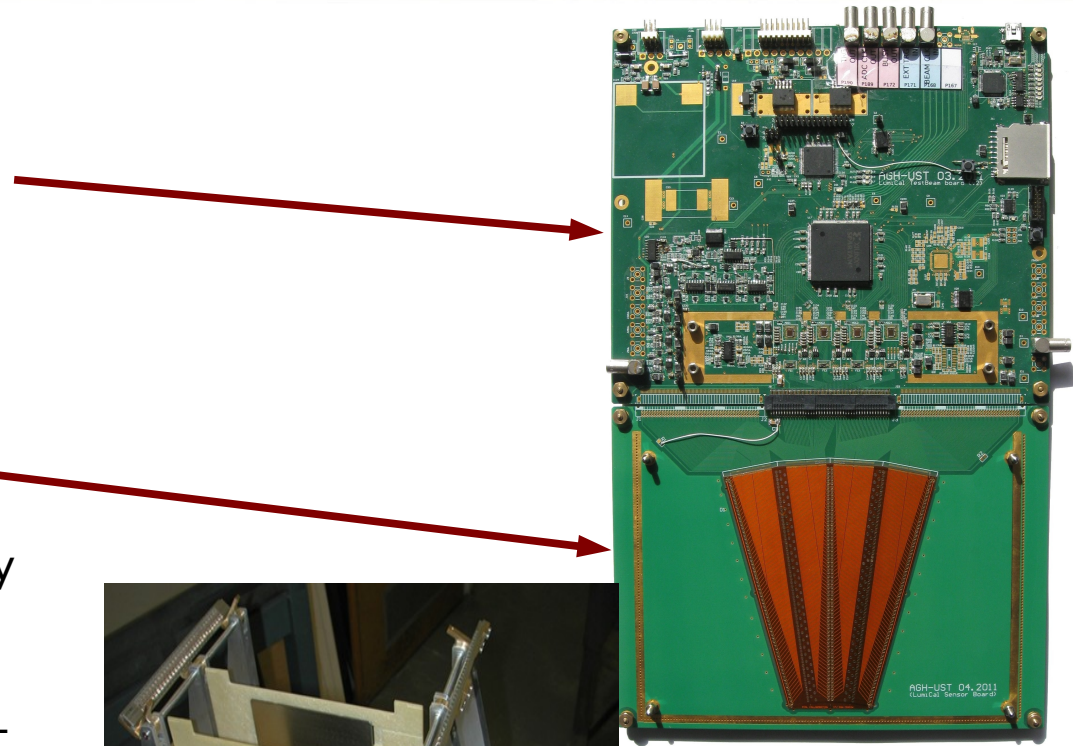

# BeamCal Sensor R&D

## DESY-JINR collaboration on GaAs sensors

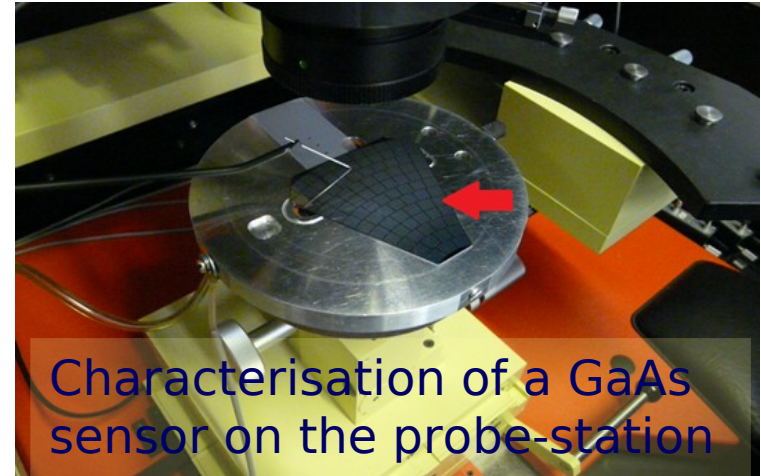
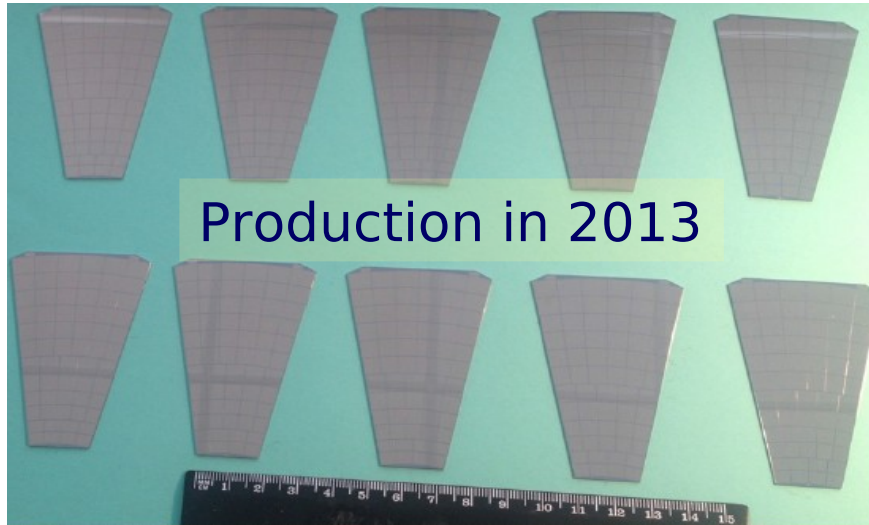

- Test of the guard ring
- Measurement of leakage current for each pad
- Set criteria for later use in the prototype calorimeter

***The aim is to produce good sensors for 30 BeamCal layers***

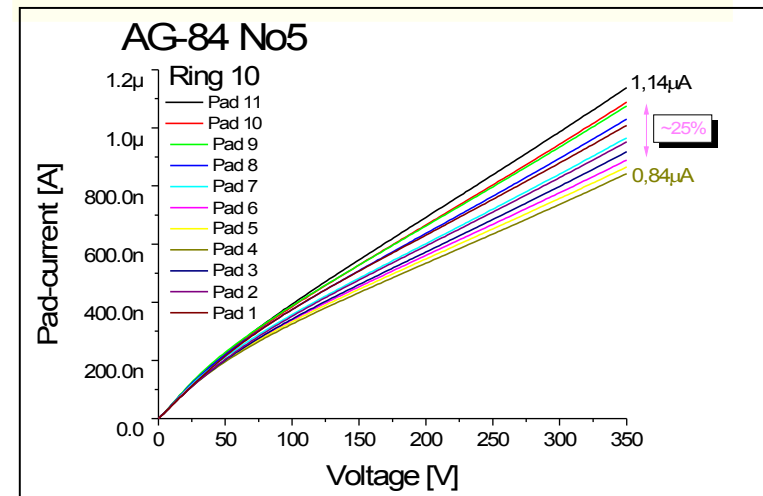



# Sensor R&D – new activity

## Irradiations of prototypes at UC Santa Cruz & SLAC

Extension of radiation hardness studies to silicon using a realistic particle composition (tungsten pre-radiator)

- 4-10 GeV electron beam
- 21mm of tungsten
- N-type Magnetic Czochralski silicon strip sensors at (-10 - 5) °C

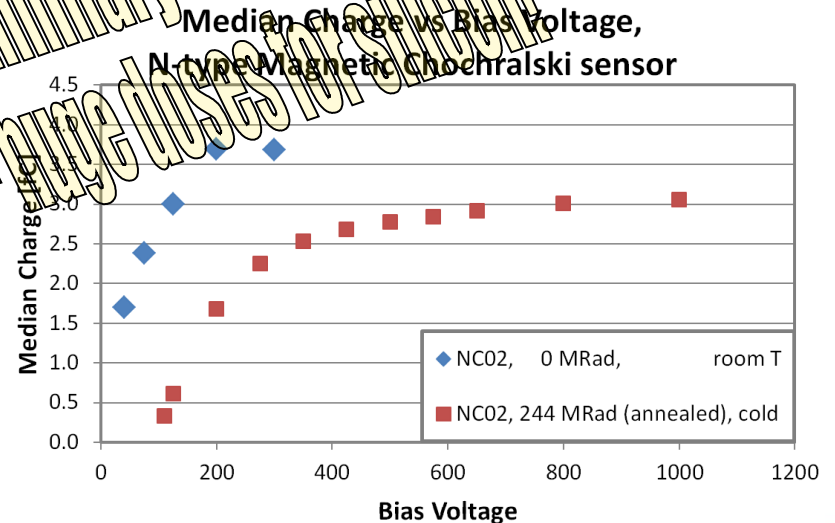
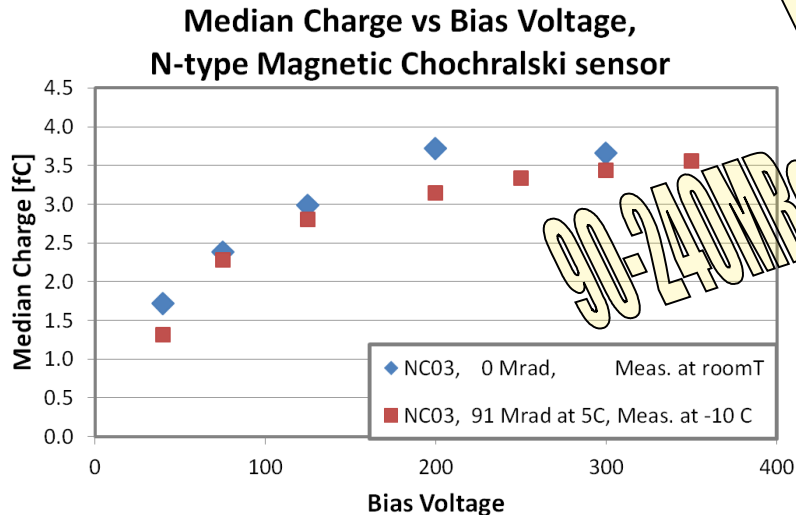

# Readout R&D in IBM CMOS 130 nm

## Development of LumiCal readout at AGH-UST

### AIDA milestone

*New readout in 130 nm has very similar architecture to existing one in 0.35um but should consume much less power and be radiation resistant*

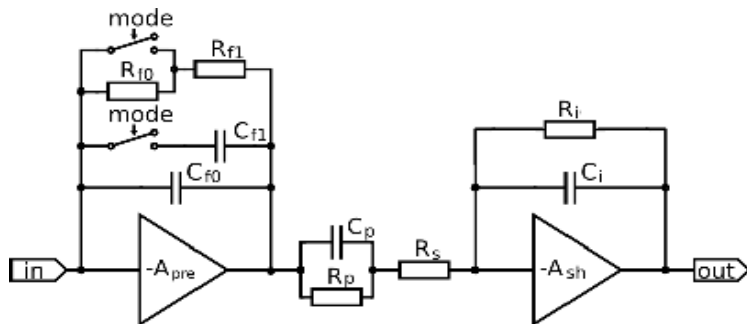
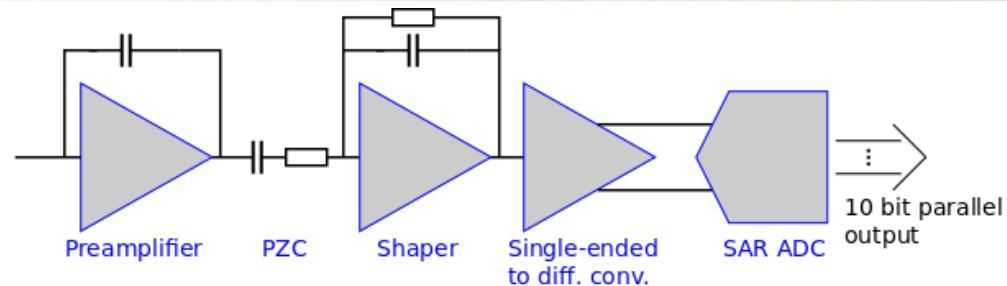

#### Front-end specs:

- $C_{det} \approx 5 \div 50 \text{ pF}$
- 1st order shaper ( $T_{peak} \approx 50 \text{ ns}$ )
- Variable gain, two modes:
  - calibration: MIP sensitivity
  - physics:  $Q_{in}$  up to  $\sim 6 \text{ pC}$
- Power pulsing implemented
- Peak power cons.  $\sim 1.5 \text{ mW/channel}$

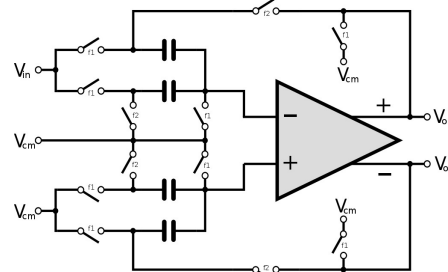

#### Single-to-Diff specs:

- Max freq.  $> 40 \text{ MHz}$
- Power pulsing
- Peak power  $\sim 0.5 \text{ mW}$

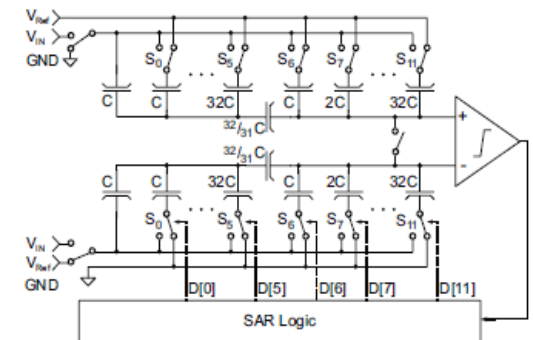

#### ADC specs:

- 10-bit resolution
- Architecture: SAR ADC with segmented/split DAC
- Max frequency  $> 40 \text{ MHz}$
- Power pulsing
- Peak power 1-2 mW @40MHz



# Readout R&D in IBM CMOS 130 nm

## Development of LumiCal readout at AGH-UST

### AIDA milestone

**Front-end and Single-to-Diff conv.**

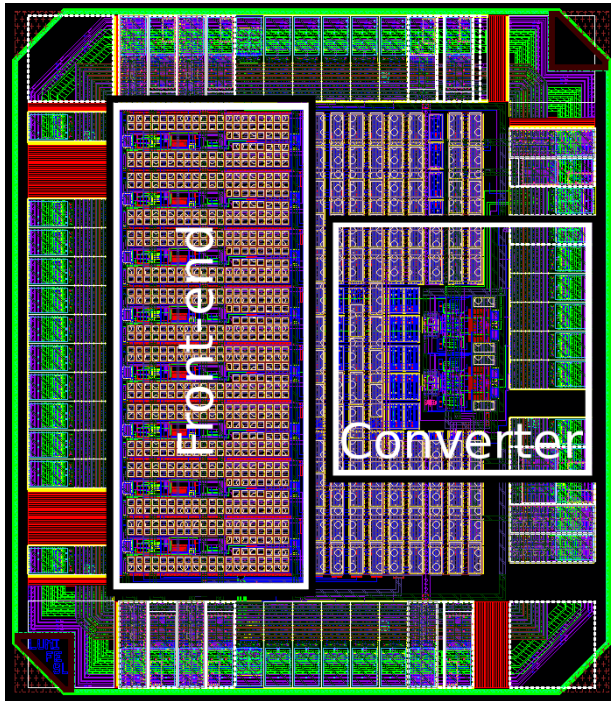

Few channels ASIC designed and submitted in February 2013

**We are just starting the tests, first signals seen 2 days ago...**

**10-bit SAR ADC**

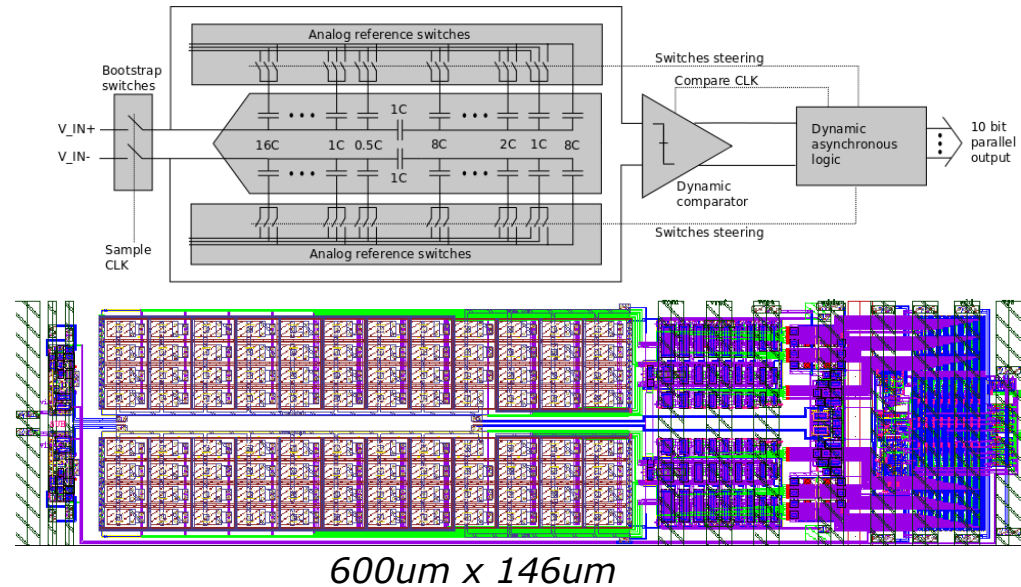

Designed and fabricated in 2012

**Tests in advanced stage (next slide)**

# Readout R&D in IBM CMOS 130 nm

## 10-bit SAR ADC measurement results

### AIDA milestone

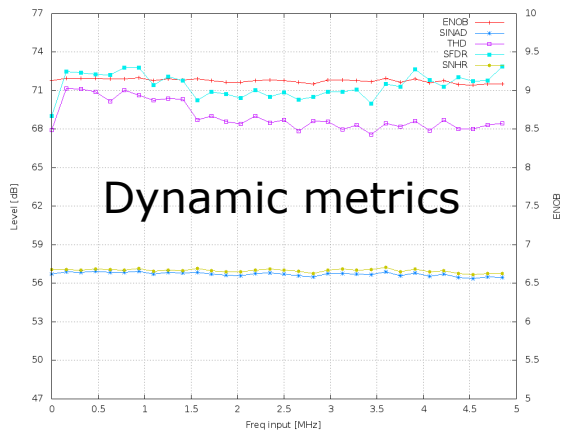
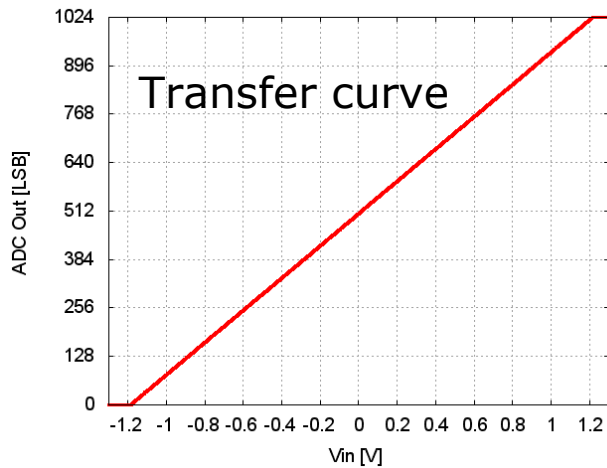

### INL/DNL measurements

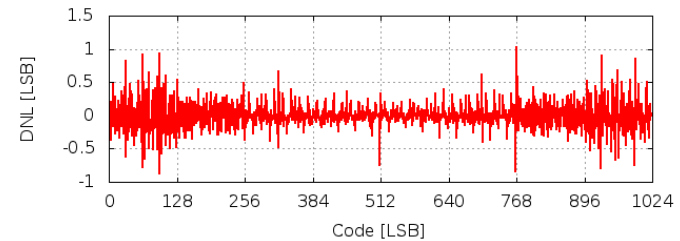
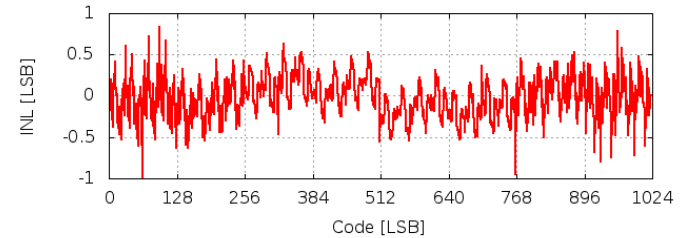

### Power consumption

- At 40MS/s  $\sim 1$  mW
- Power scaling  $\sim$  **25 uW/channel/MHz**
- In AMS0.35um it was 1 mW/channel/MHz
- With power pulsing (1% duty cycle)  
 $\sim$  **0.25 uW/channel/MHz**

- ADC is fully functional, has ENOB $\sim$ 9.2 and consumes very low power
- Linearity can be further improved...

# Readout R&D in IBM CMOS 130 nm

## Multichannel SAR ADC with data serialization

### AIDA milestone

#### Specifications :

- 8 channels of 10-bit SAR ADC
- Layout with 146um ADC pitch
- Max. sampling frequency 40 MHz
- Multimode digital multiplexer/serializer:
  - Serial mode: one link per all channels
  - Parallel mode: one link per channel
  - Test mode: single channel output
- PLL for data serialization
- High speed SLVS interface (>1GHz)
- Power pulsing

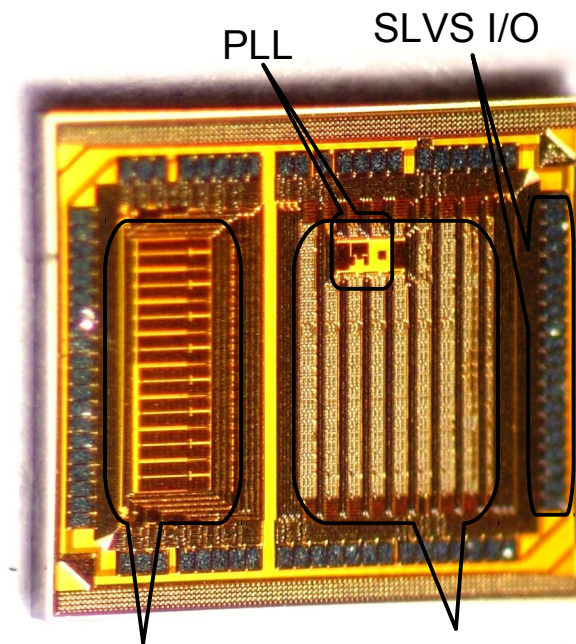

8 ADC channels

Digital part –  
multiplexing &  
serialization

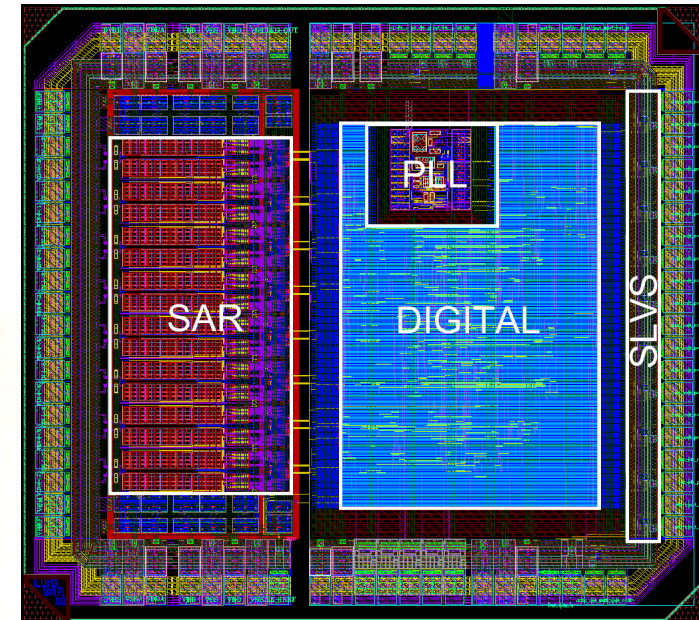

2200um x 2000um

**Tests will start soon...**

# Readout R&D at PUC Chile

## BeamCal detector Readout ASIC

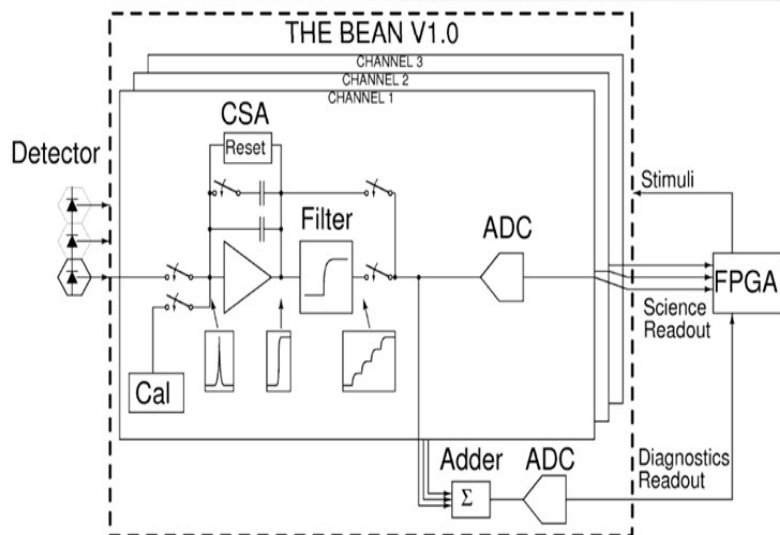

- 180 nm TSMC technology
- BEAN readout ASIC R&D:
  - Front-end: noise analysis for discrete systems in progress
  - Prototype of 10-bit SAR ADC designed and under test

Front-end studies:  
Z-domain processing  
allows configurable  
filters: with arbitrary  
weighting functions and  
optimized parameters

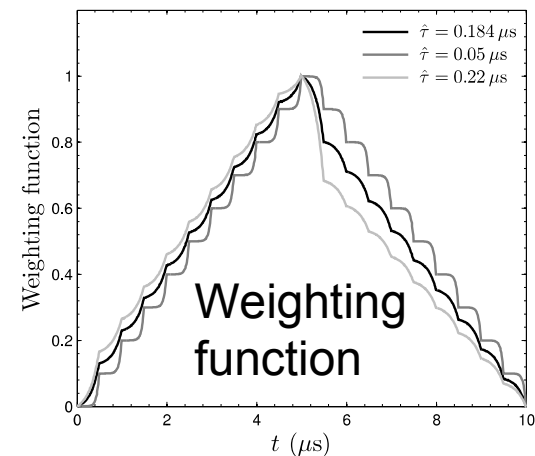
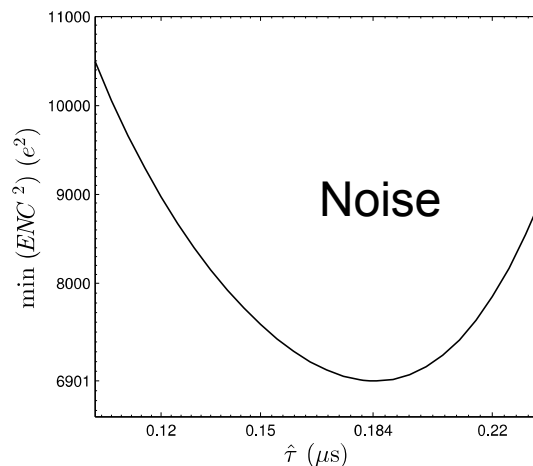



# Readout R&D at PUC Chile

## 10-bit SAR ADC

ADC uses systematic process mismatch to correct nonlinearity

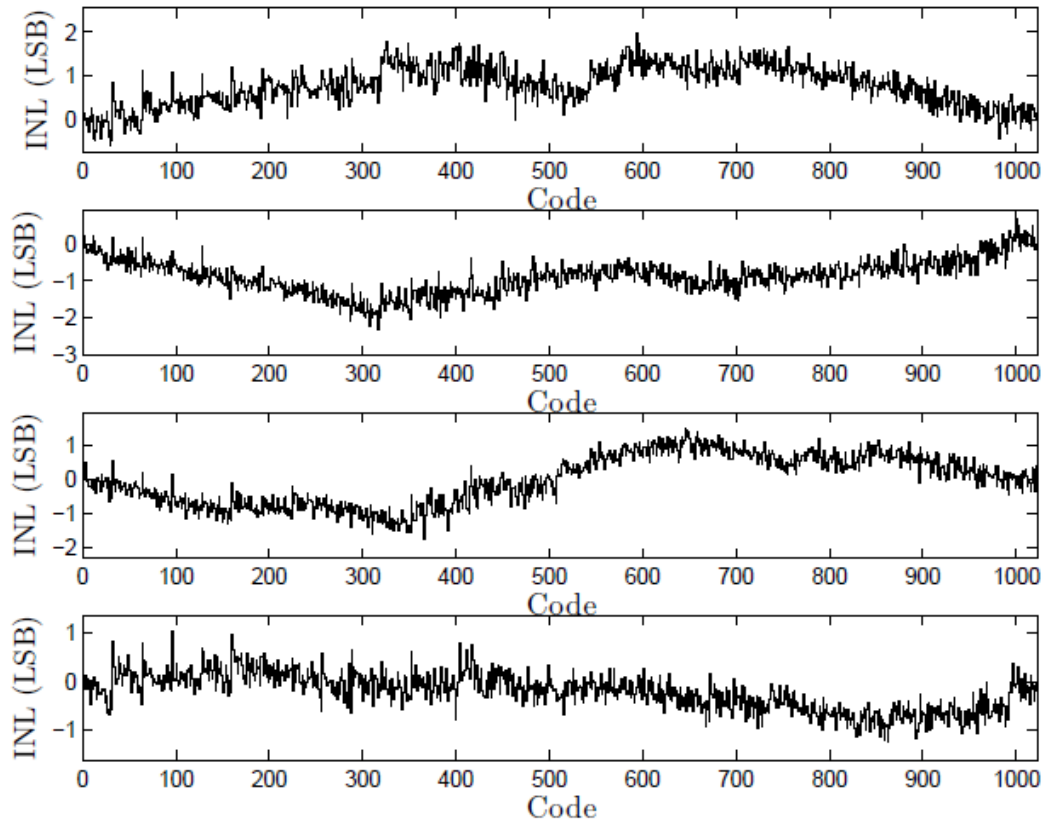
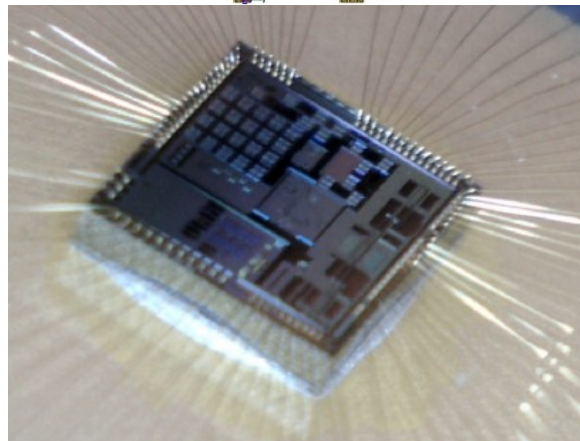
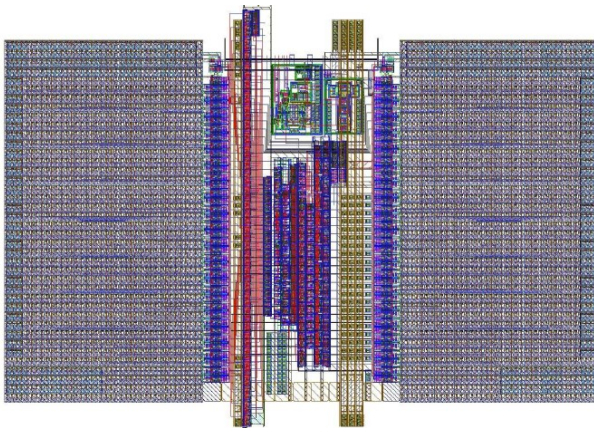



# ILC vs CLIC beam timing

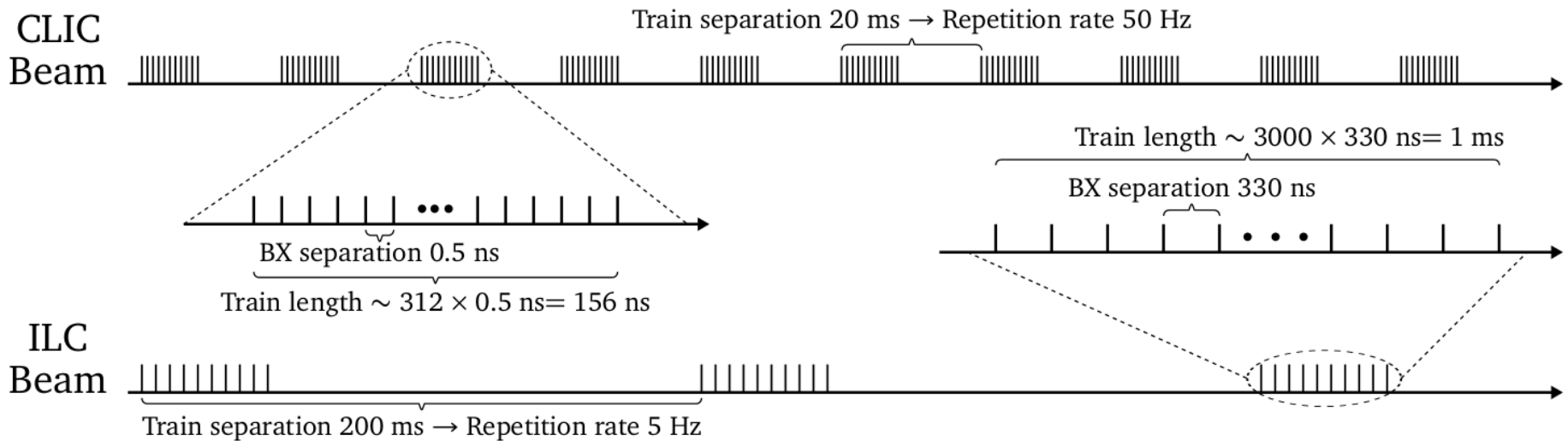

- Very low duty cycle ( $\ll 1\%$ ).
- Power pulsing reduces significantly average power consumption
- Readout electronics should allow fast power switching.



AGH

# Gated integrator +CDS as possible readout for high rate signals

Operation:

- Reset before the beam train
- Integration during the beam train (156ns for CLIC)

Occupancy of LumiCal pads

due to incoherent noise

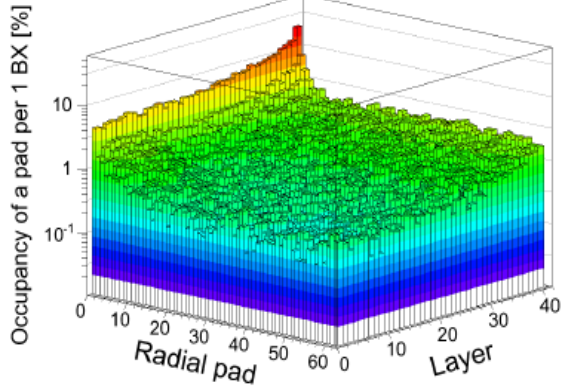

*“Physics and Detectors at CLIC”, CLIC Conceptual Design Report 2011*

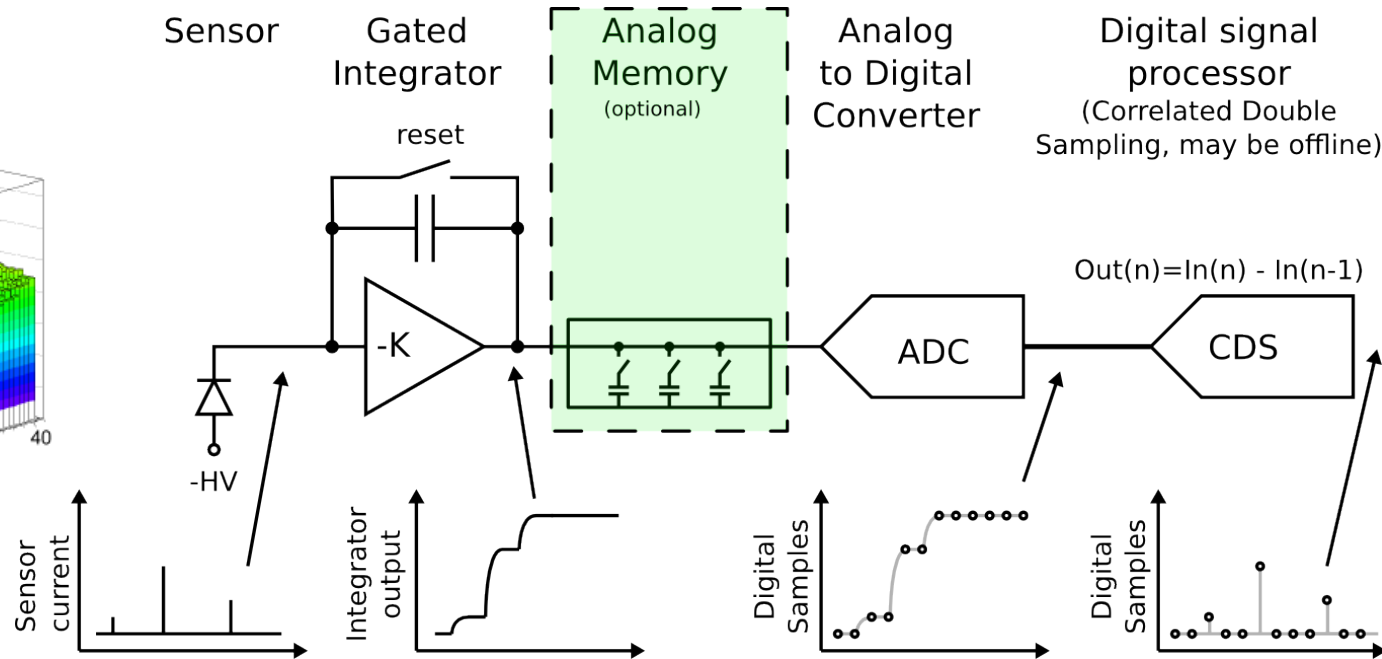

Sz. Kulis, M. Idzik, “Study of readout architectures for triggerless high event rate detectors at CLIC”, CERN LCD-Note-2011-015 2009

# Laser alignment R&D at INP PAN LumiCal Laser Alignment System (LAS)

- The proposed laser alignment system for LumiCal combines two components:
- infra-red laser beam and semi-transparent position sensitive detectors (PSDs) - **already available**
  - tunable laser(s) working within Frequency Scanning Interferometry (FSI) system - **in preparation**

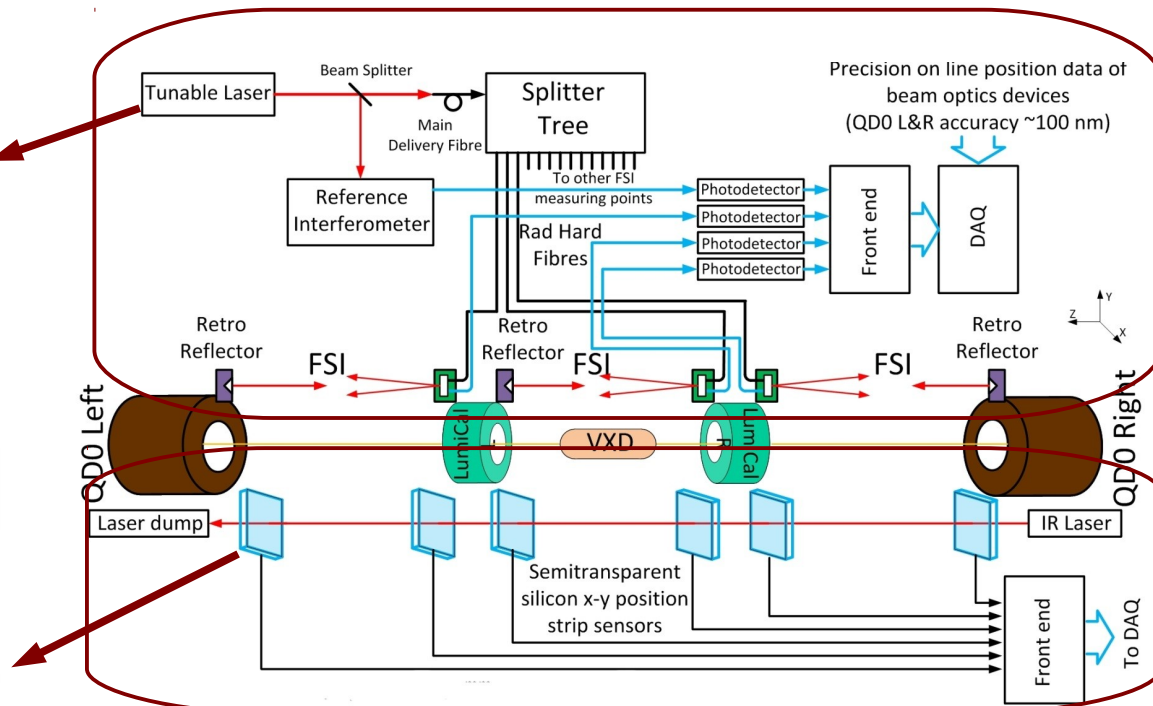
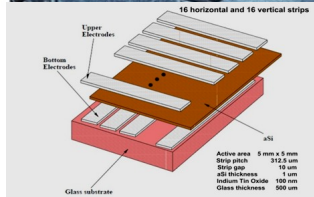
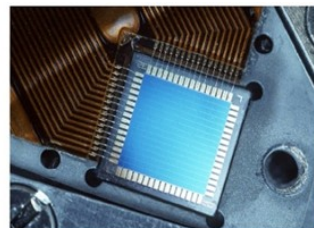
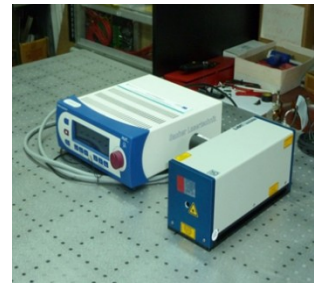

FSI – using tunable lasers will measure the absolute distance between LumiCal calorimeters by measurement of interferometer optical path differences (counting the fringes)

Semi-transparent sensors : LumiCal displacements of the internal Si layers and detectors relative positions

# Laser alignment R&D at INP PAN

## Semi-transparent sensors

Laboratory setup : 6 PSD sensors

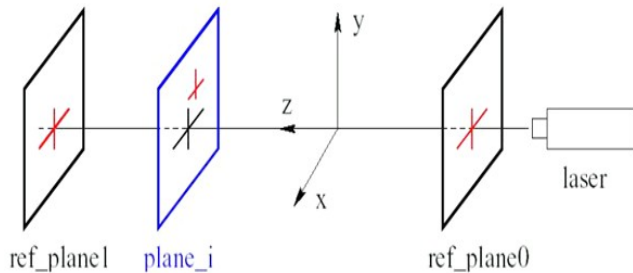

Laser beam-profile signals from anode of sensors measured along beam line

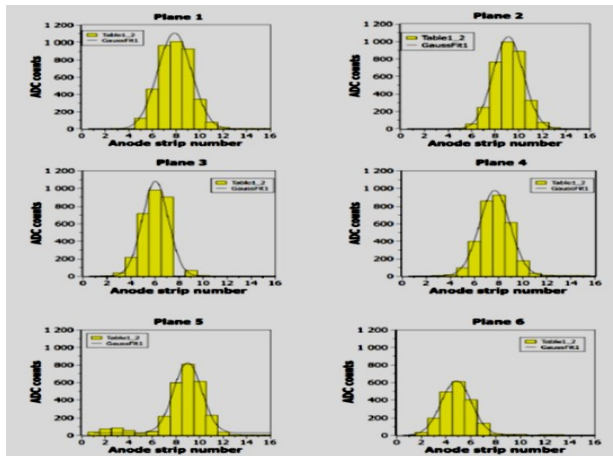

LAB prototype system with optical movable 2D table. It allows studies of sensor behaviour, laser beam and calculation of displacements. Expected accuracy: few microns

## Future Plans

- Completion of AIDA program (2014/2015)
  - Flexible mechanical frame with tungsten plates
  - New multichannel readout ASICs for LumiCal in IBM 130 nm
- New LumiCal readout module with new ASICs
- Prototyping of dedicated FE and ADC ASICs for BeamCal
- Development of DAQ system (TelAviv, INP PAN)
- Irradiation tests of prototype sensors for BeamCal
- MC studies to refine design and contribute to the physics program (various FCAL groups)



## Organization issues

- A new LC management structure is established.  
R&D collaborations need a representation
- New FCAL management:
  - Spokesperson: W. Lohmann (DESY)
  - Deputy: M. Idzik (AGH-UST)
  - IB chair: Ivanka Bozovic-Jelisavcic (VINCA)will strengthen the level of commitments
- In Europe FCAL got limited support up to 2015 within FP7 and GIF, needs effort
- Essential, albeit limited, support by grants from national funding agencies
- At **DESY** a new funding period starts in 2015, **support for FCAL unclear, needs strong effort**