



27.09.2013 – Greek Teachers Programme

Energy & Modern Technology

Konstantinos Papastergiou | Technology Department
CERN – European Organisation for Nuclear Research



Summary

- ➔ **Energy consumption at CERN**
 - ⇒ How is energy spent?
 - ⇒ Electricity, Water and Gas
- ➔ **From Electrical to Kinetic Energy**
 - ⇒ How is electricity converted to speed?
- ➔ **Key electrical consumers?**
 - ⇒ Components with power requirements
- ➔ **Electronics and Power Electronics**
 - ⇒ What is the difference
- ➔ **Power Conversion Principle**
 - ⇒ Why and how is energy converted
- ➔ **Accelerator Power Electronics**
 - ⇒ Real world systems – how do they look
- ➔ **Research Challenges**
 - ⇒ The future in powering accelerators

Ποιος ενδιαφέρεται για το CERN?

Ας δούμε τι έχει να πει το GOOGLE



cern

Recherche Google

J'ai de la chance

Λεδωμένα: Πανγκόσμια - 2008
Λεδωμένα: Πανγκόσμια - 2004-σημεία
2008

Regional interest



Regional interest



Electricity at CERN

- ➔ Interconnections to both France and Switzerland
- ➔ Approximately 80% of electricity from France
 - ⇒ (nuclear mostly)
- ➔ Special contract terms with EDF and SIG
- ➔ 1000 high voltage circuit breakers in operation
- ➔ Consumption
 - ⇒ as high as all households in Geneva area
 - ⇒ 1/10th of the canton (11.3TWh).

Energy Facts & Figures

➔ Total consumption 1 000 000 000 kWh/yr

⇒ 43% consumed by the LHC

- Up to 14% by superconductive magnet cooling
- Up to 9% equipment cooling and tunnel ventilation

⇒ 11% by its Experiments

⇒ 30% by SPS

- 7% at its experiments

⇒ 3% PS-booster-Linac

⇒ 6% Data Centers

⇒ 7% in offices, restaurants etc.

Water

- ➔ 6 million m³ of water
- ➔ Closed circuit of demineralised water and secondary circuit of raw water cooled in cooling towers.
- ➔ Industrial process water
 - ⇒ Surface treatment
 - ⇒ Production of demineralised water

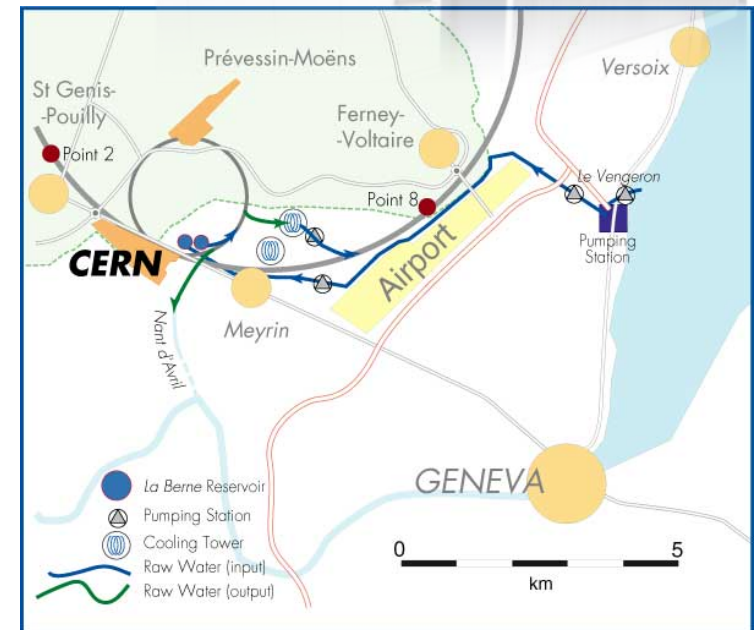

Natural Gas

- ➔ Heating stations at Meyrin 8 million m³
- ➔ Heating station at Preveessin – 1.5million m³
- ➔ Operated by external companies
 - ⇒ Monitor dust, CO, CO₂, nitrogen oxides and sulphur oxides

Accelerators at CERN

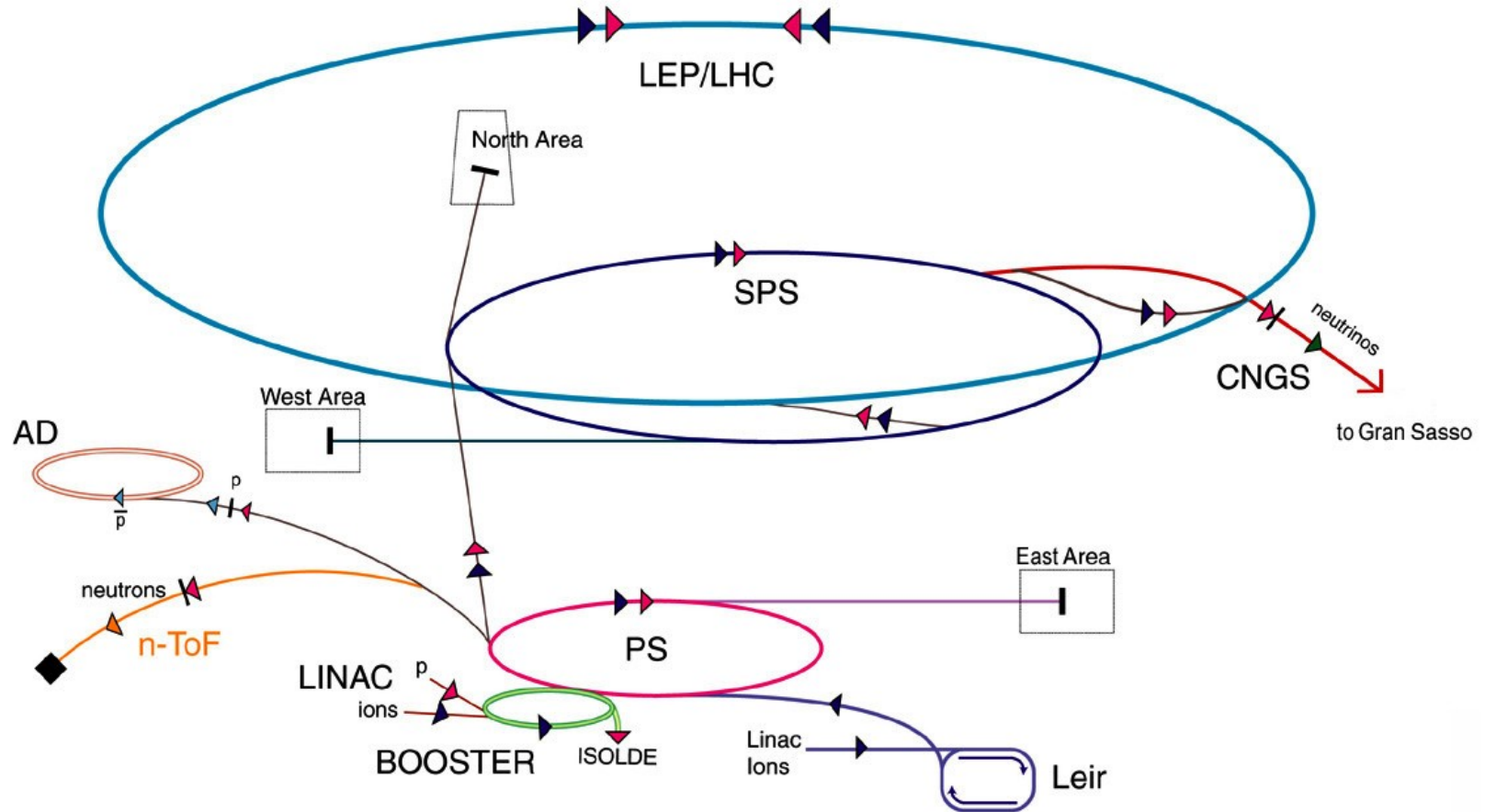

- ▶ p (proton)
- ▶ ion
- ▶ neutron
- ▶ \bar{p} (antiproton)
- ▶ proton/antiproton conversion
- ▶ neutrino

- AD Antiproton Decelerator
- PS Proton Synchrotron
- SPS Super Proton Synchrotron

- LHC Large Hadron Collider
- n-ToF Neutron Time of Flight
- CNGS Cern Neutrinos Gran Sasso

Key Energy Consumers

➔ Direct Energy to the beam

- ⇒ RF cavities – Klystron tubes
- ⇒ Magnets (dipoles, multi-poles)

➔ Environmental Conditioning

- ⇒ Cryogenics
- ⇒ Systems cooling
- ⇒ Tunnel air filtering

➔ Data

- ⇒ Measurements
- ⇒ Processing

➔ Infrastructure

➔ Other

(c) Rey.Hori / KEK

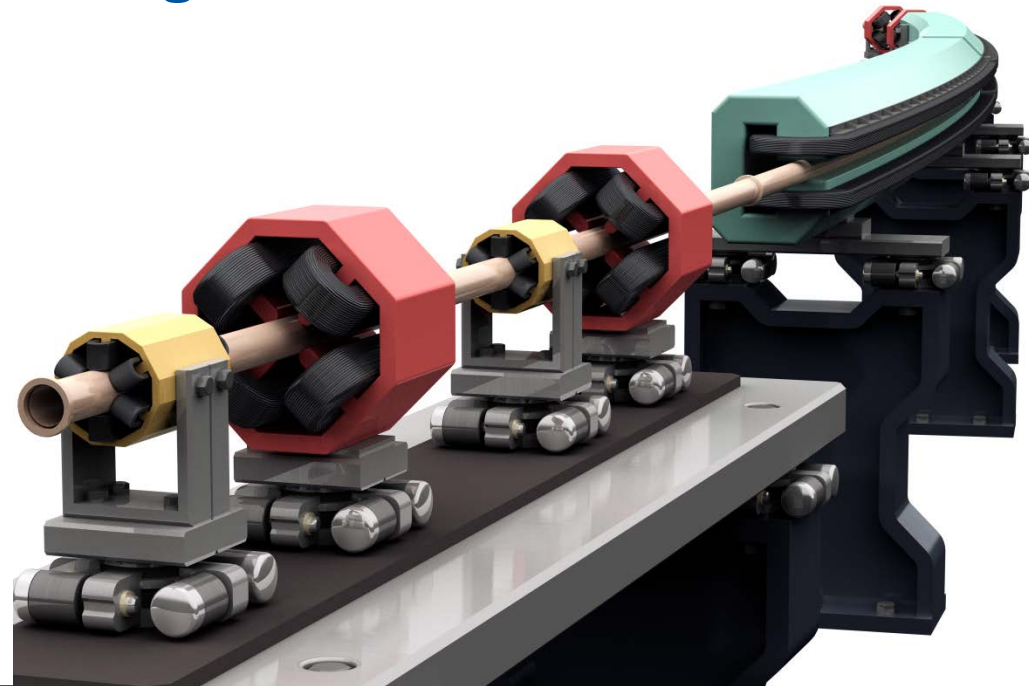

RF Cavities - Klystron

Functions:

- Particle acceleration

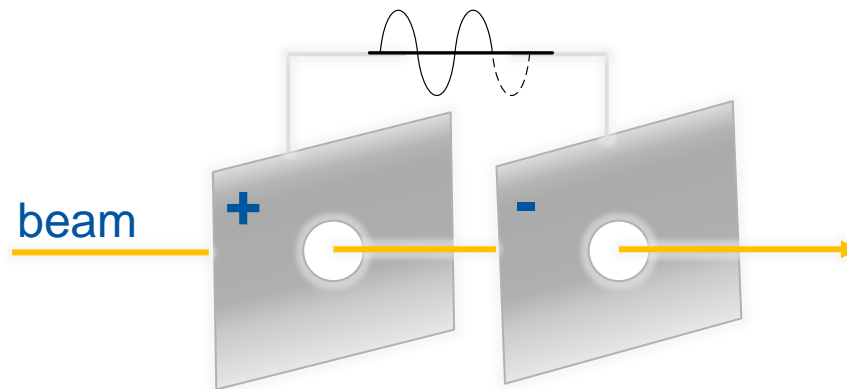
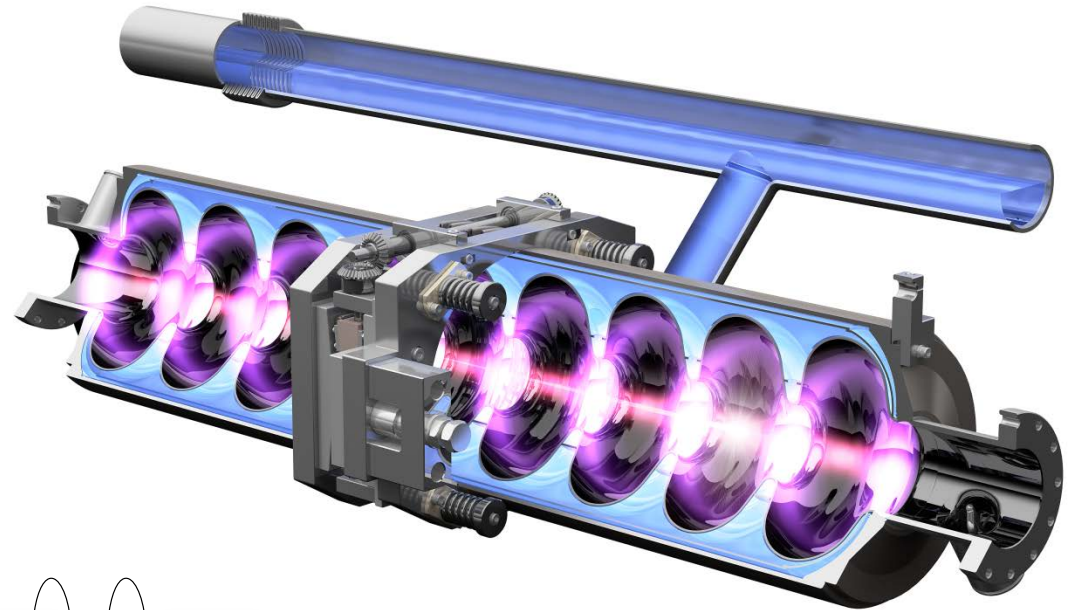

(c) Rey Hori / KEK

Electro-magnets

Functions:

- Beam steering
- Beam focussing-defocussing
- Beam chromaticity



(c) Rey Hori / KEK

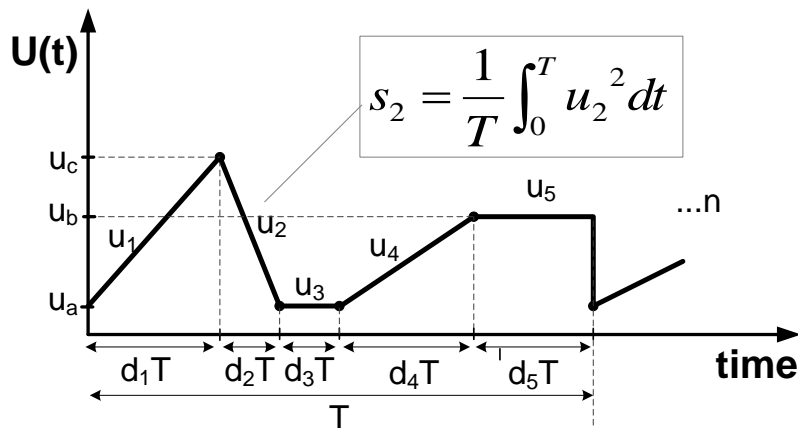

- Stores energy $E=0.5 L I^2$
- Consumes power $P=I^2 R$

Cryogenics

- ➔ Cryogenic pumps are the greatest electrical consumer at CERN
- ➔ Total power: 27.5MW
- ➔ 6 weeks to cool down Helium to 1.8K to 4.2K



Electronics & Power Electronics

- ➔ Electronics is the art of manipulating the flow of Electrons to perform certain functions
 - ⇒ Receive, transmit and store information
 - ⇒ Generate electromagnetic waves (heat, light)
 - ⇒ Convert electricity to kinetic energy

Analog & Digital Electronics



Power Electronics



Power Conversion

- ➔ Electrical voltage needs to be transformed
 - ⇒ From dc to ac and the opposite
 - ⇒ From one voltage to another
 - ⇒ From one frequency to another

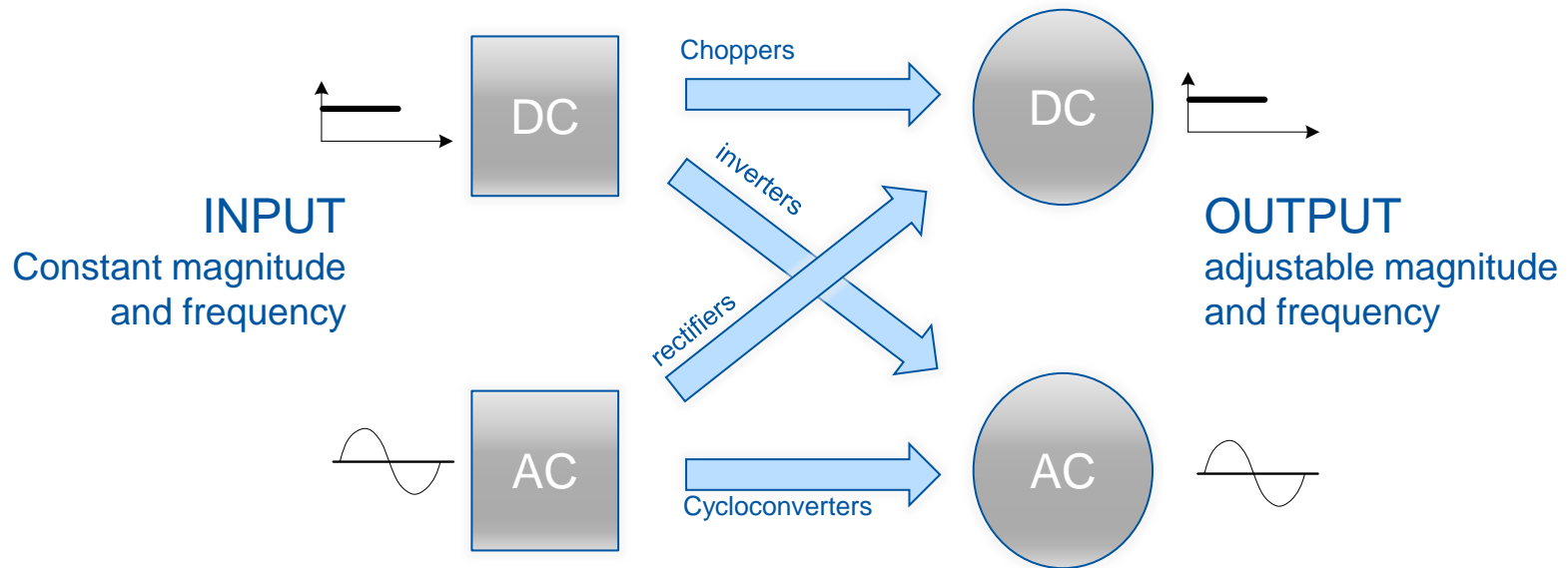

The basic power converter

- ➔ Voltage regulator operation based on switching **on** and **off** the input source with a duty cycle D .
- ➔ Inductor operates as averaging device

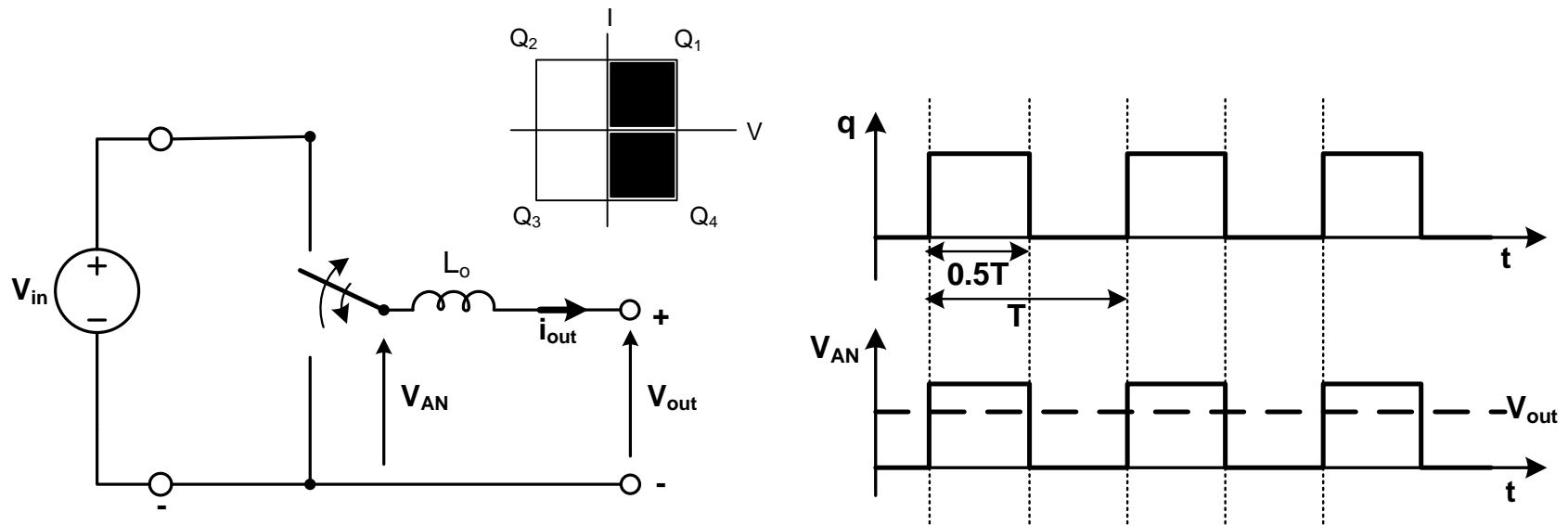

$$V_{out} = D \cdot V_{in} \quad 0 < D < 1$$

Power Converter Structure

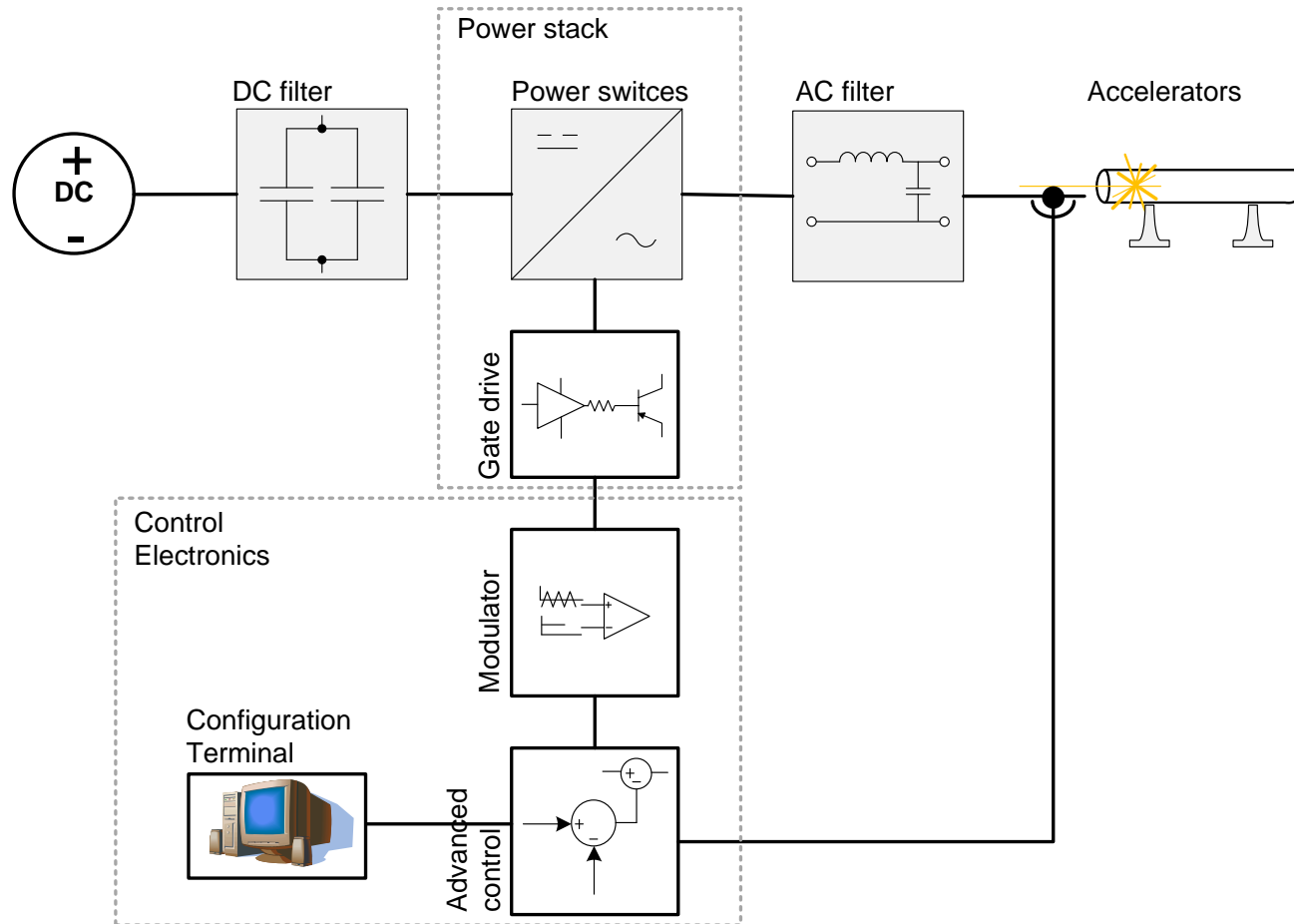

Power Semiconductors

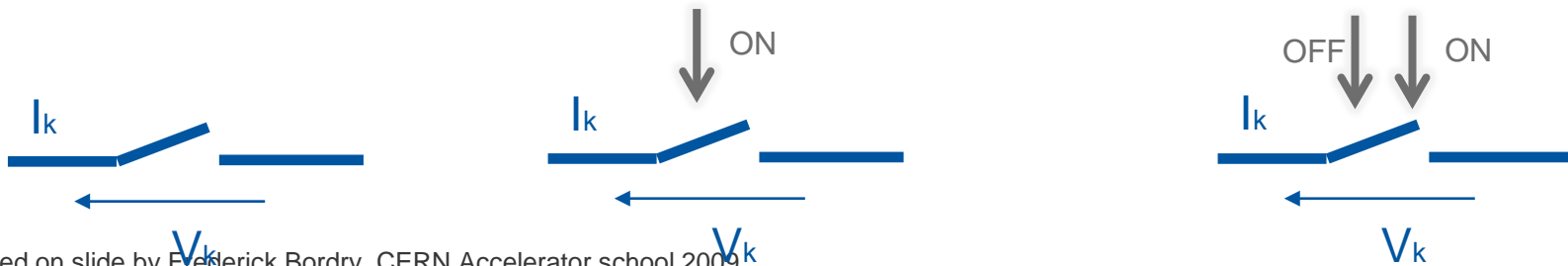
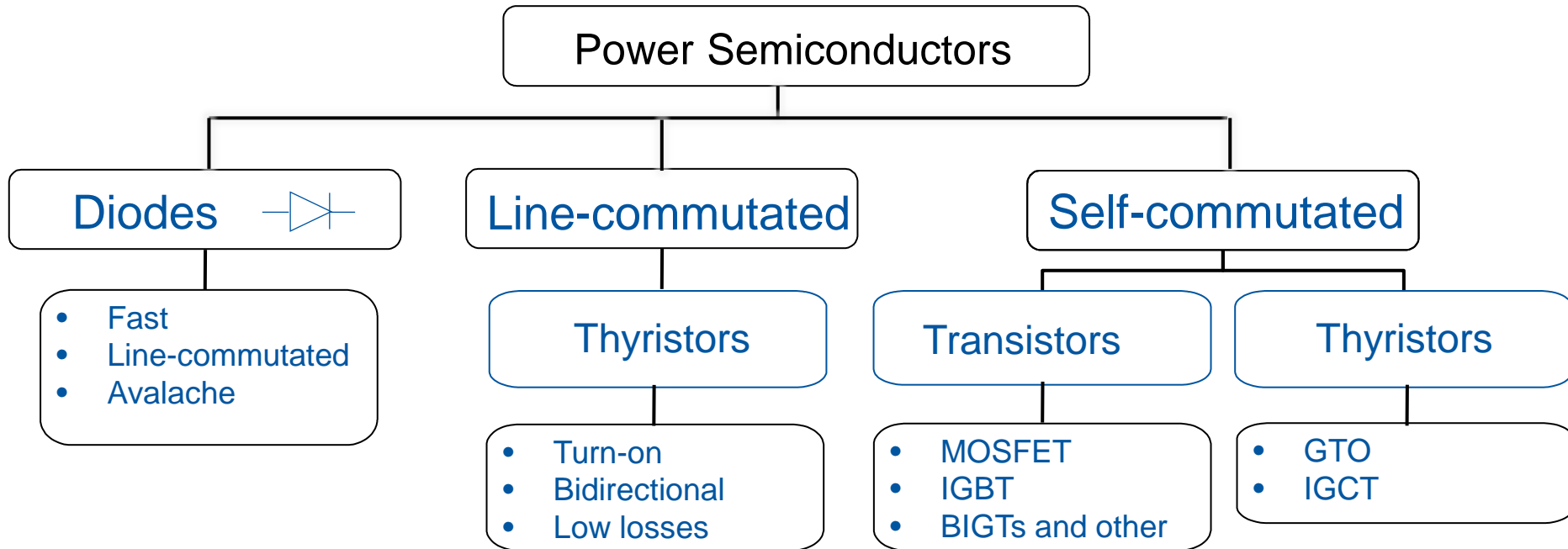

Based on slide by Frederick Bordry, CERN Accelerator school 2009

Modulation

- ➔ Control of the fundamental frequency component (ac or dc) by varying the switch duty ratio

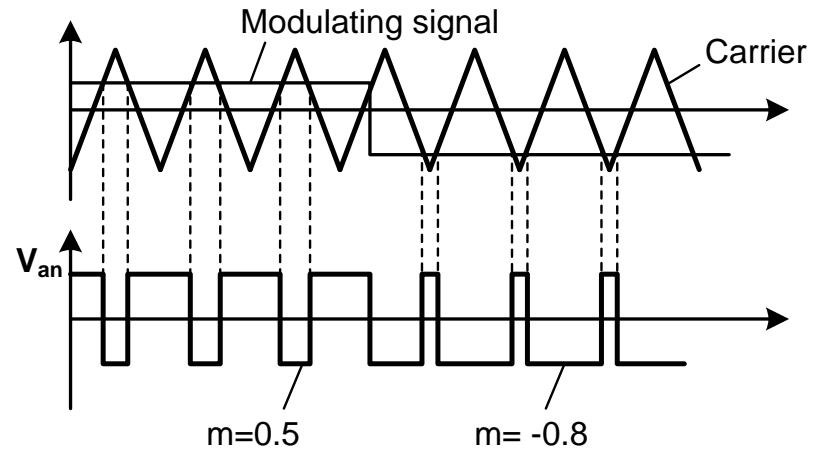
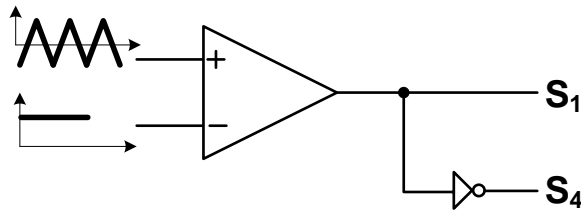

Figures of Merit in power electronics

➔ Power conversion efficiency

⇒ Expresses the effectiveness of a converter in converting input power to useful output power (with less wasted power in the process)

$$\eta_c = \frac{P_{out,dc}}{P_{in}}$$

➔ Input Power factor

⇒ A high power factor typically indicates a lower input current for delivering a certain output power level. (as usually input sources have a stiff voltage magnitude)

$$\cos\varphi = \frac{P_{in}}{S_{in}}$$

➔ Ripple factor

⇒ Is a measure of the voltage or current ripple magnitude in dc voltage or current waveform

$$RF = \frac{V_{ac,rms}}{V_{dc}}$$

➔ Total Harmonic Distortion (THD)

⇒ is a measure of its RMS power of the harmonic components in comparison with the RMS power of the fundamental component of a voltage or current waveform.

$$THD = \frac{V_{h,rms}}{V_{1,rms}}$$

LHC – the Large Hadron collider

→ The beams are controlled by:

- 1232 SC Main Dipole magnets to bend the beams
- 392 SC Main Quadrupole magnets to focus the beams
- 124 SC Quadrupole / Dipole Insertion magnets
 - (in 196 circuits of ~ 6 kA)
- 6340 SC Corrector magnets
 - (in 1460 circuits 60 to 600A)
- 112 Warm magnets
 - (in 38 circuits 600 to 900A)
- SC RF Cavities to accelerate and stabilize the beam

All ~8000 magnets need to be powered in a very controlled and precise manner

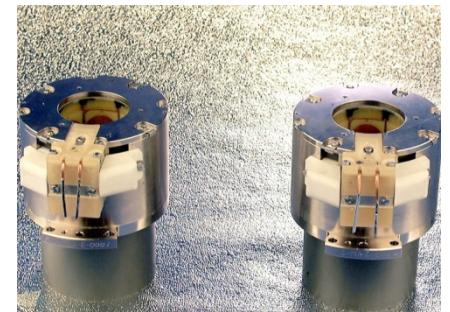

Converter operating modes

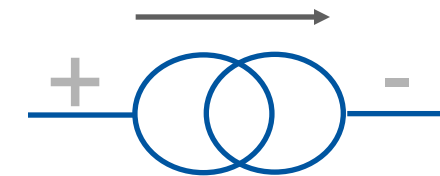

1 Quadrant mode

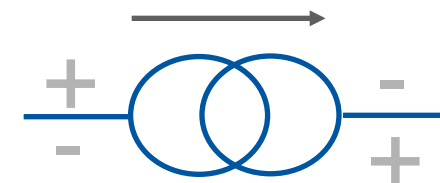
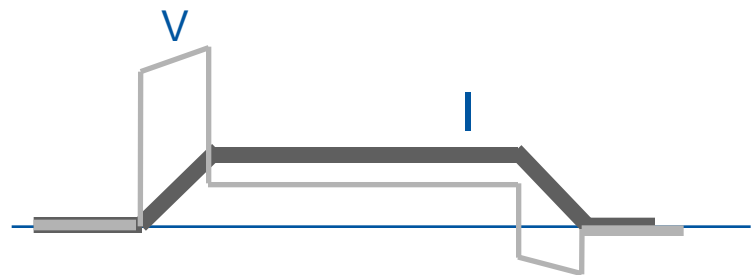

2 Quadrants mode

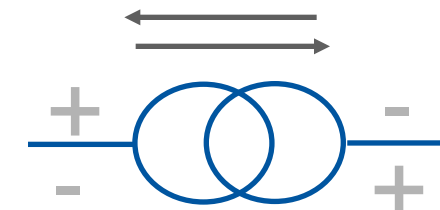
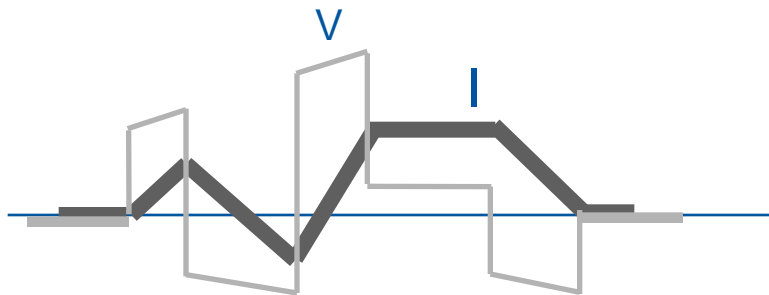

4 Quadrants mode

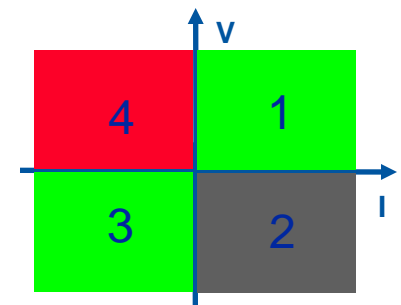

Current Precision

Current in a transfer line magnet

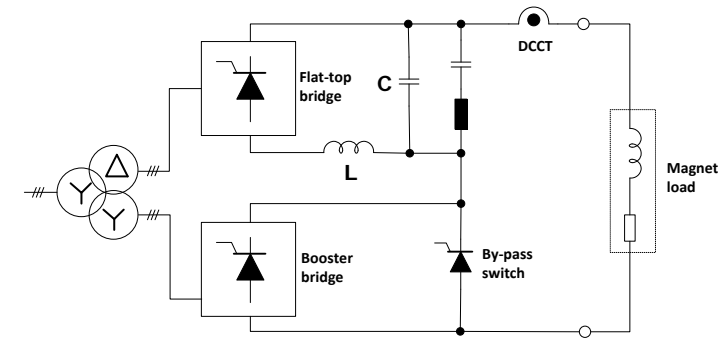
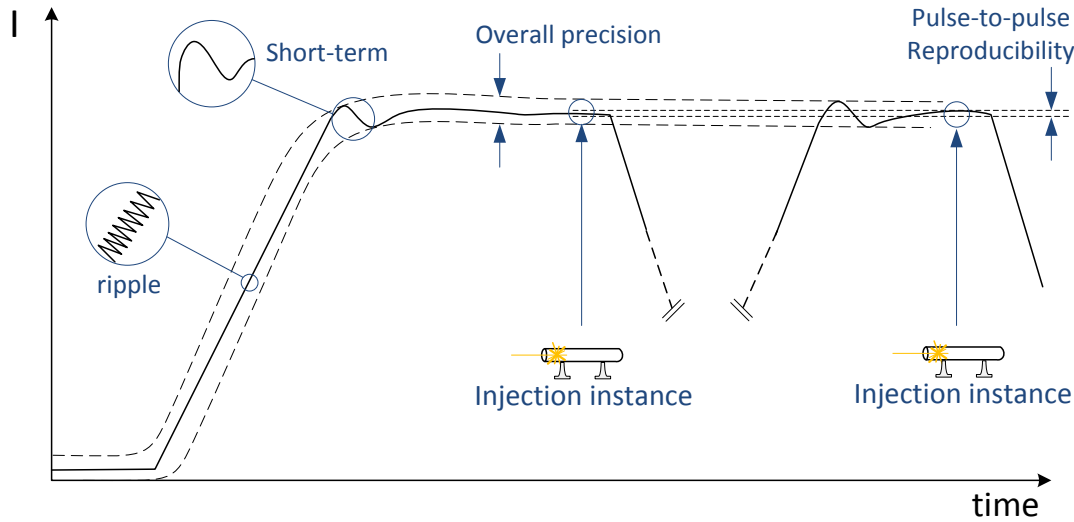

Precision components:

- Current ripple
- Short-term (dynamic behaviour)
- Long term (reproducibility)

Typical requirements:

- 1-100ppm depending on application

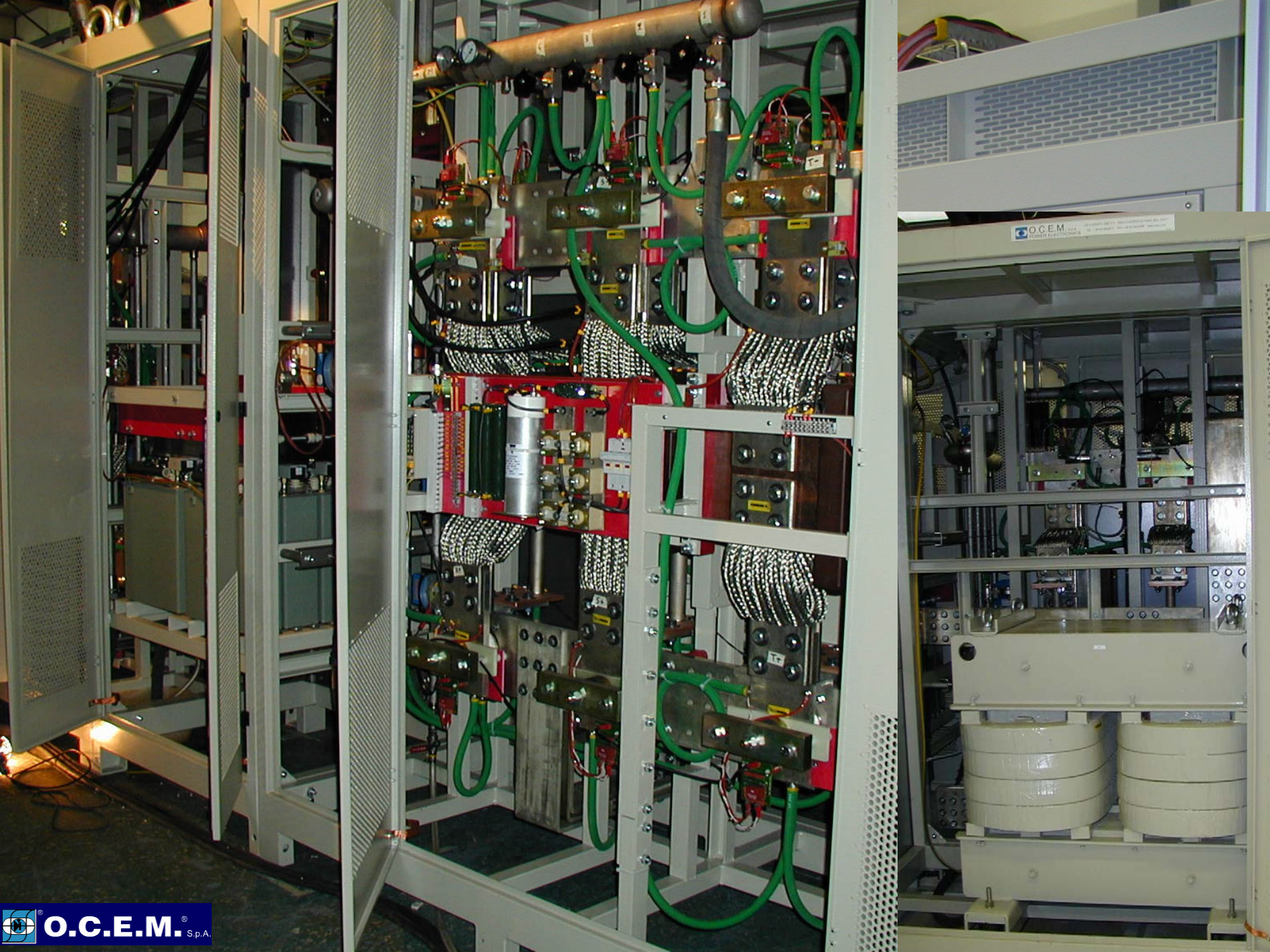

O.C.E.M. S.p.A.
POWER ELECTRONICS

20kA power converter -CMS Solenoid

The load

- Superconducting magnet: $L = 14\text{H}$
- Nominal current: 20 kA
- Stored energy: 2.8 GJ
- Time constant: 39 hours
- Time for current ramping up: 3h15m
- Energy extraction system (resistor bank, not shown)

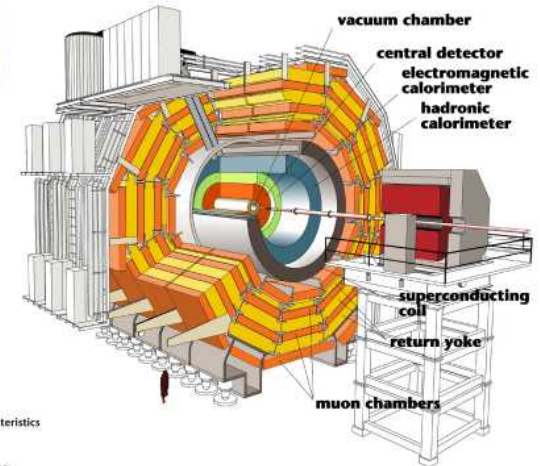

The power converter

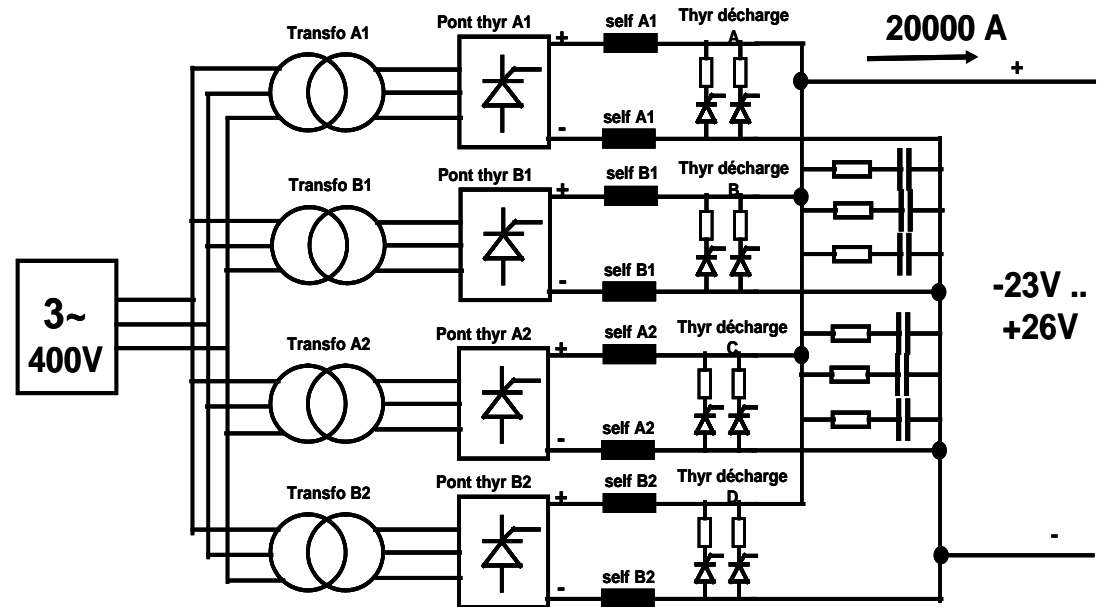

Equipaggiamenti Elettronici Industriali

Slide by Frederick Bordry, CERN Accelerator school 2009

Converter modularisation

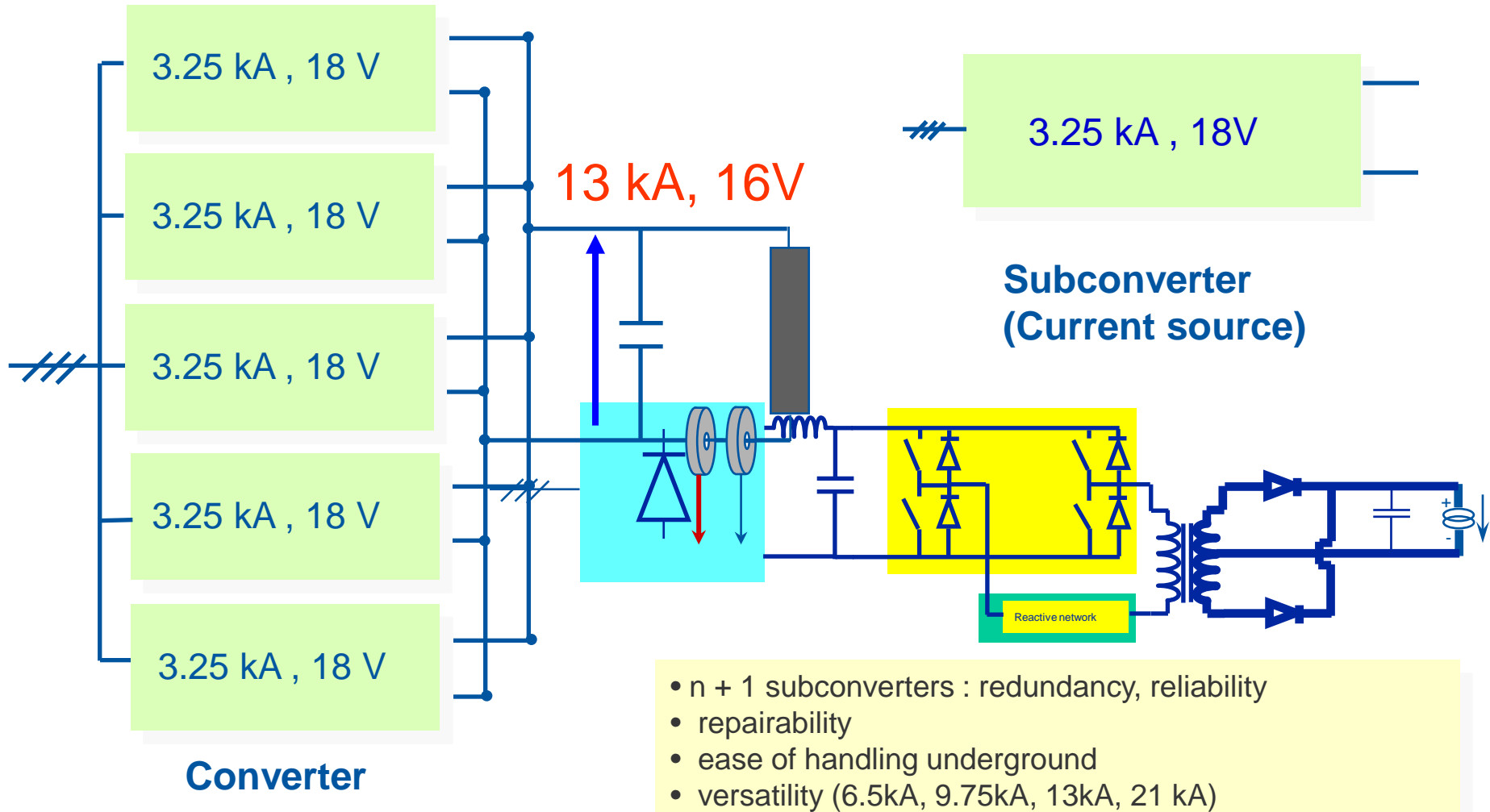

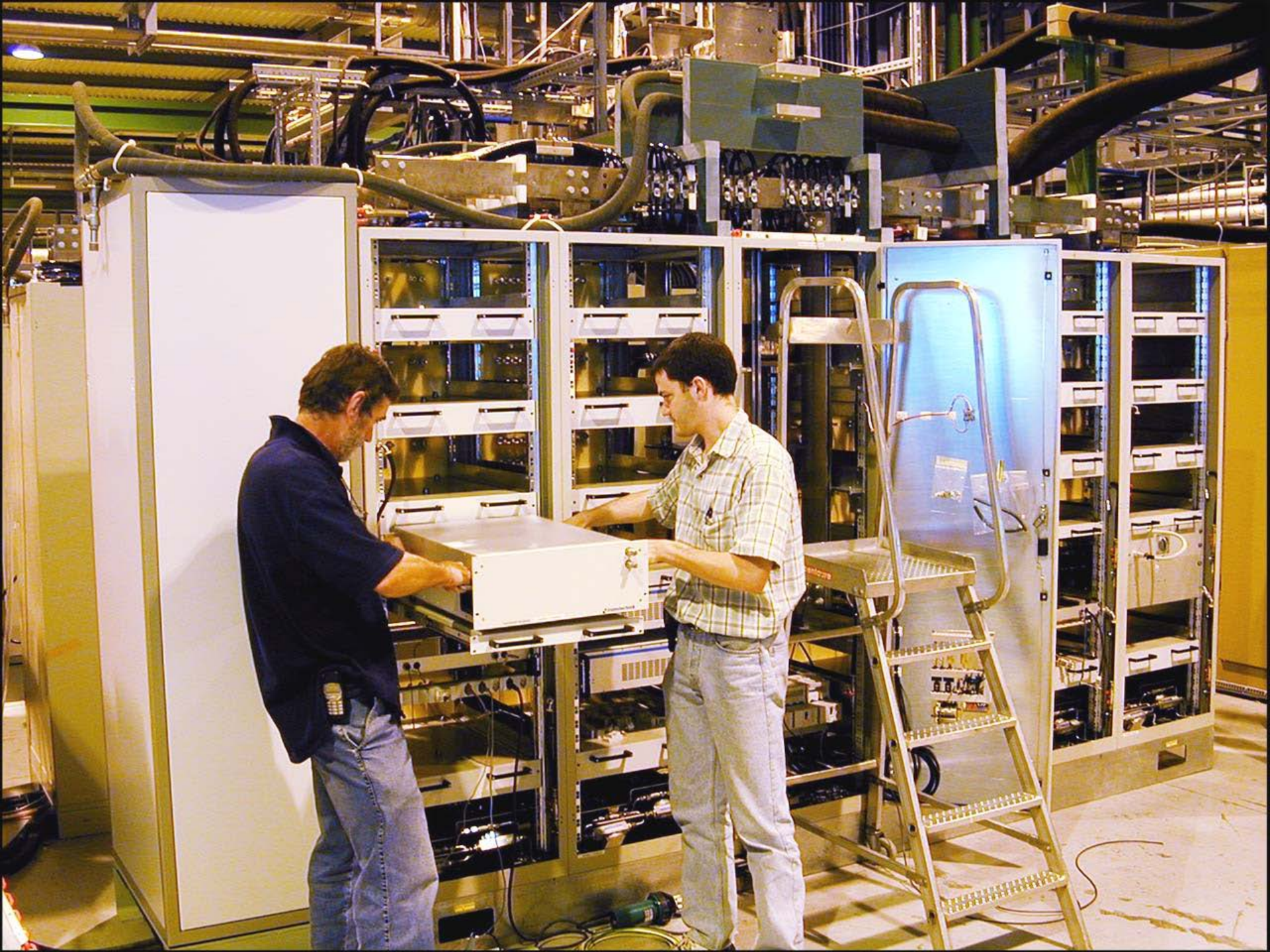

20.5kA power converter – ATLAS solenoid

The load

- Superconducting magnet: $L = 7.5 \text{ H}$
- Nominal current: 20.5 kA
- Stored energy: 1.6 GJ
- Time constant: 37'500 s

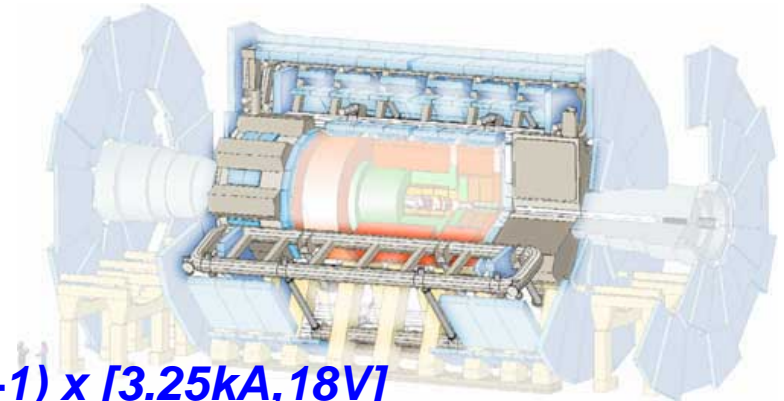

The power converter : [20.5 kA, 18V] ; (7+1) x [3.25kA, 18V]



TRANSTECHNIK

Slide by Frederick Bordry, CERN Accelerator school 2009

Digital control design

Tracking and Regulation with independent objectives

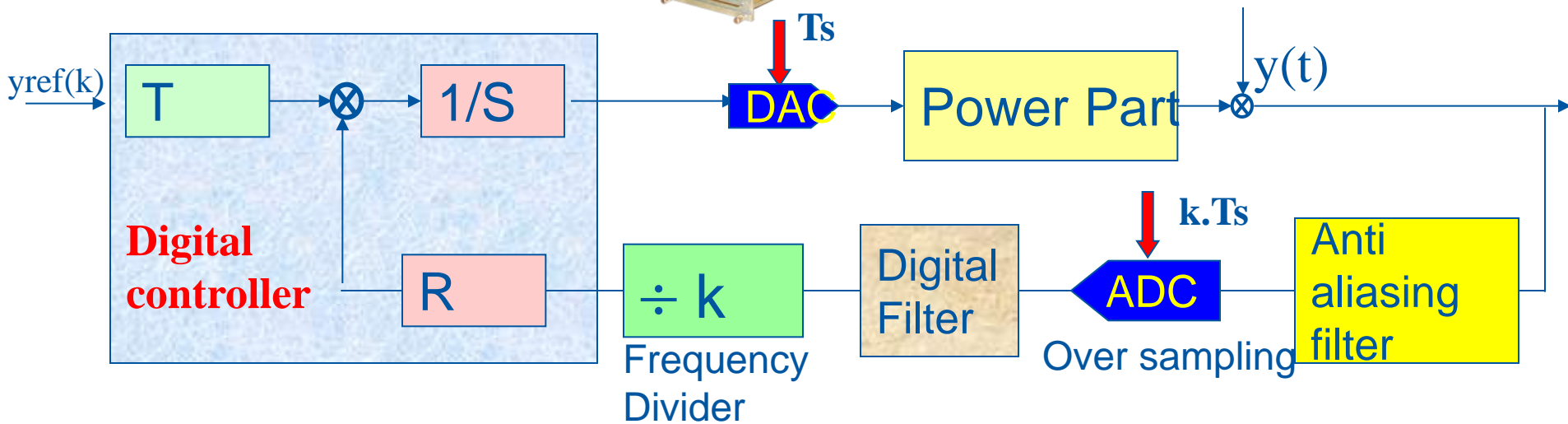
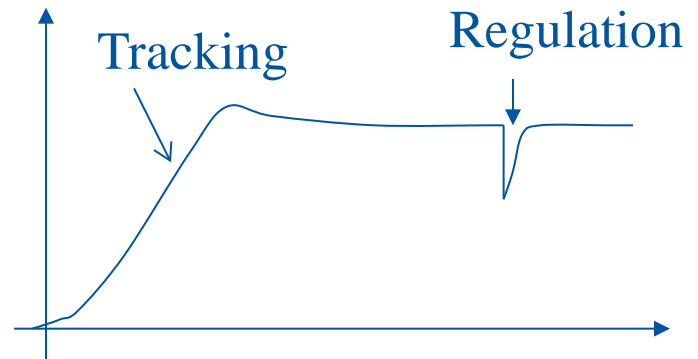

Slide by Frederick Bordry, CERN Accelerator school 2009

Power Electronics for the Future Accelerators

Compact Linear Collider (CLIC)

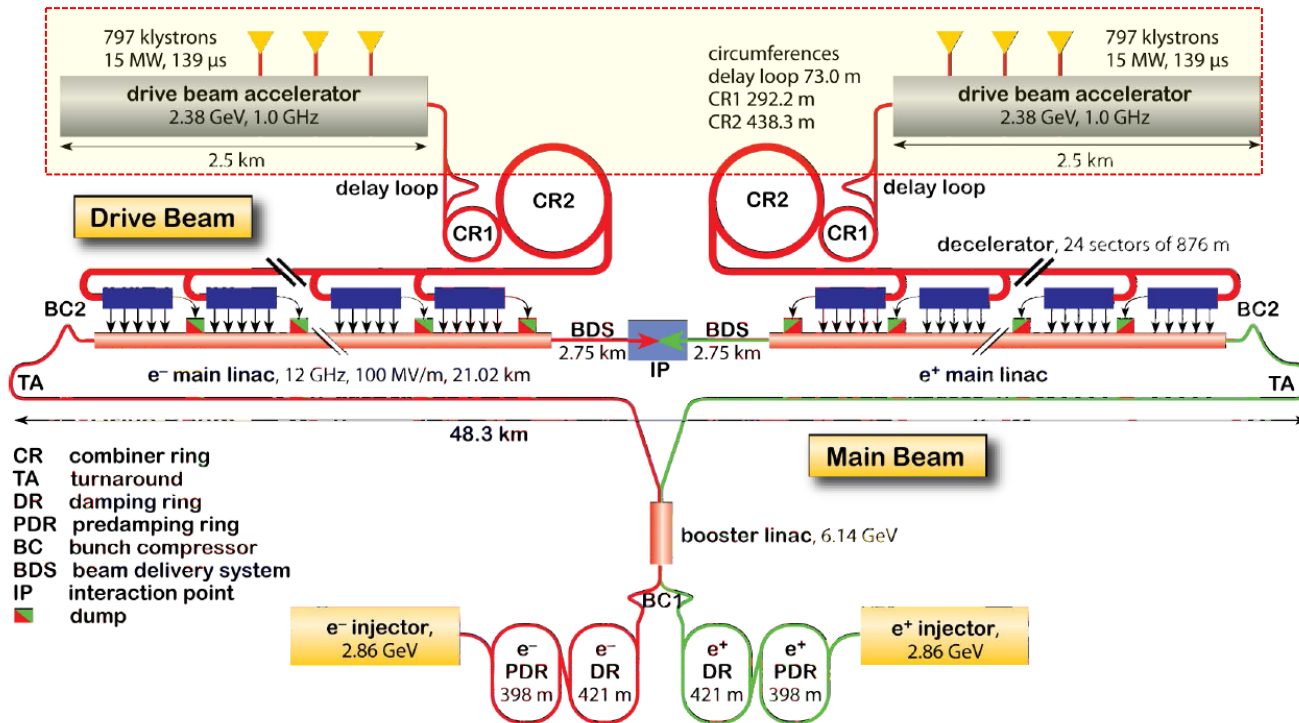

RF modulators are the primary electrical power consumer

Pulses of 139 μs 150 kV and 160 A resulting in bursts of 24 MW per modulator

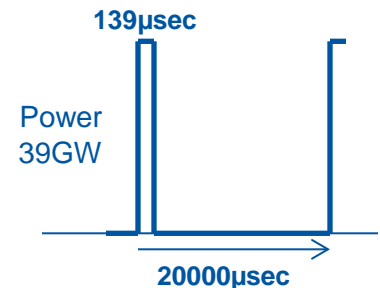

CLIC Specifications

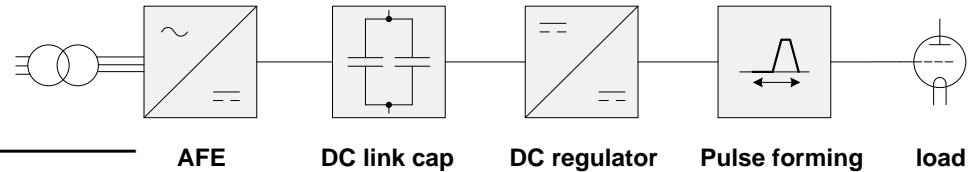

Modulator's output pulse specification

Nominal pulse voltage	V_{kn}	150	kV
Nominal pulse current	I_{kn}	160	A
Pulse peak power	P_{mod_out}	24	MW
Rise & fall times	t_{rise}, t_{fall}	3	μs
Settling time	t_{set}	5	μs
Flat-top length	t_{flat}	140	μs
Repetition rate	$REPR$	50	Hz
Voltage overshoot	V_{ovs}	1	$\%$

Precisions

Flat-Top Stability	FTS	0.85	$\%$
Reproducibility (6kHz-4MHz)	PPR	10	ppm

Efficiencies

Charger electrical efficiency	η_{ch}	96	$\%$
PFS electrical efficiency	η_{pfs}	98	$\%$
Pulse efficiency	η_{pulse}	95	$\%$
Modulator global efficiency	η_{mod_global}	90	$\%$

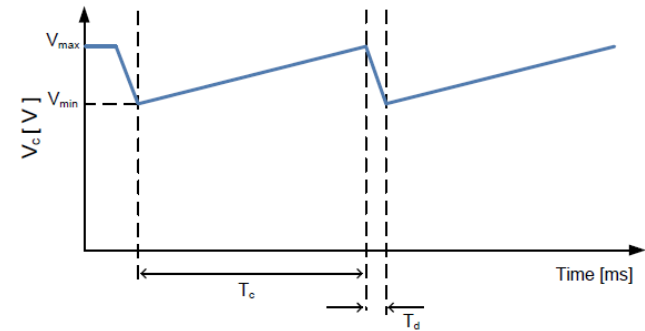

Application parameters:

- The load is 1638 Klystron tubes
- 150kV/160A 140 μs flat-top required -> 24MW peak per Klystron -> 39.3GW peak load
- Average power per klystron modulator 168kW
- Accounting for a 90% efficiency (plug to drive beam) -> total average power 275MW



– Any questions?

After Visit Reading: <http://www.cern.ch/aftervisit>

Life at CERN



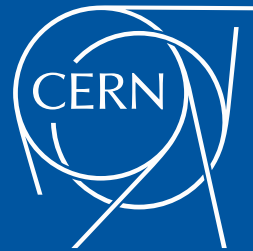

www.cern.ch