

Standards for Modular Electronics

the past, the present and the future

Markus Joos

CERN

- **The past:**
 - *QIM*
- **The present:**
 - PCI and PCIe
 - SHB Express
- **The future:**
 - **Serial interconnects**
 - *VXS*
 - *ATCA*
 - *μTCA*

Why Modular Electronics?

- As in programming a system becomes unmanageable if too much functionality is put into a single functional block
- Modularizing DAQ electronics helps in these respects:
 - Allows for the **re-use** of generic modules in different applications
 - **Limiting the complexity** of individual modules increases their reliability and maintainability
 - You can profit from **3rd party support** for common modules
 - Makes it easier to achieve **scaleable designs**
 - **Upgrades** (for performance or functionality) are less difficult
 - Etc.

Why use Standards?

- Benefit from **3rd party products, services and support**
- **Competition** gives you **better prices** and **alternative suppliers**
- Standards make it easier to define **interfaces** between sub-systems
- But not all standards are equally good:
 - **Too old**: poor performance, few suppliers, expensive
 - **Too new**: Interoperability issues, unclear long term support
 - **Too exotic**: Too few suppliers (sometimes just one)

NIM

- Initially (1964): NIM = Nuclear Instrument Modules
 - But it was used outside of "nuclear science"
 - Therefore: NIM = National Instrument Modules
 - But it was used outside of the USA
 - Therefore: NIM stands for NIM

NIM modules (usually)

- Need no software
- Are not connected to a computer
- Are used to implement trigger logic

These functions (any many others) are available

- Discriminators
- Coincidences
- Amplifiers
- Timers
- Logic gates (and / or)
- Level converters
- HV power supplies
-

NIM crate

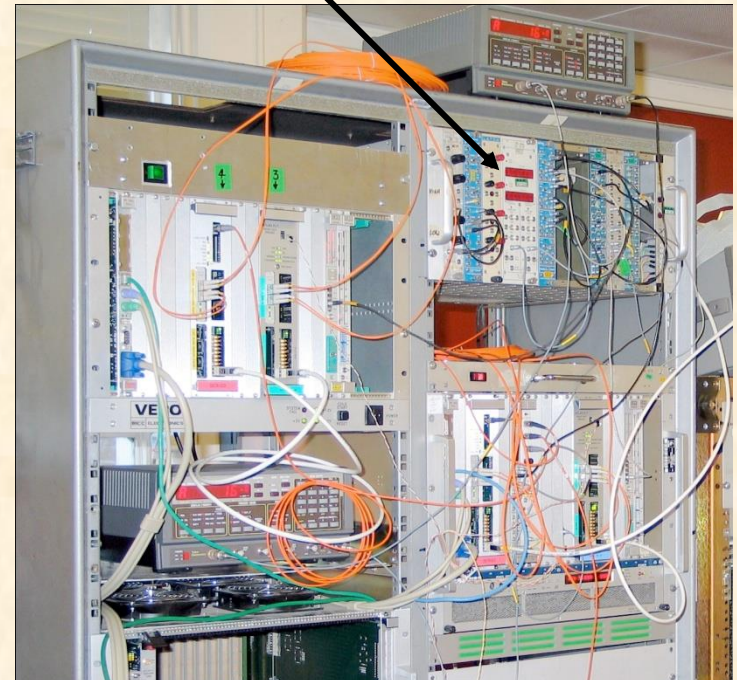

A small DAQ system 3

NIM basics

- 1st NIM standard: **July 1964**
 - 1st commercial module: November 1964
- Module dimensions: 34 x 221 x 246 mm
- NIM logic levels:
 - **0 = 0A (0V)**
 - **1 = -12 to -32 (typical -16) mA at 50 Ω (-0.8V)**
- NIM connector
 - 42 pins in total
 - 11 pins used for power (+/- 6, 12, 24V)
 - 2 logic pins (reset & gate)
- 29 pins reserved since 1964
- 1983 NIM digital bus (IEEE 488 – GPIB)
 - Rarely used

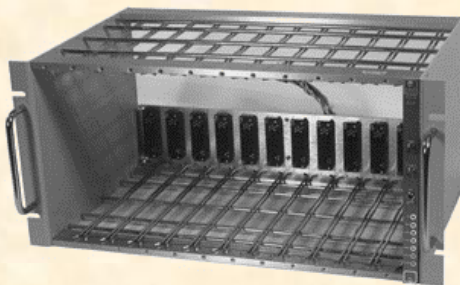
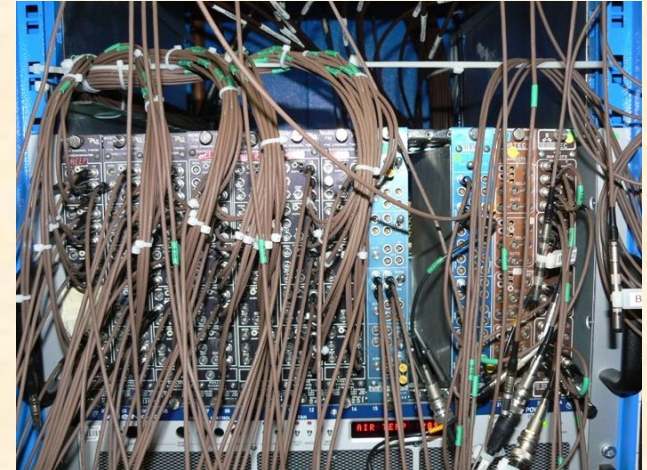

NIM connector

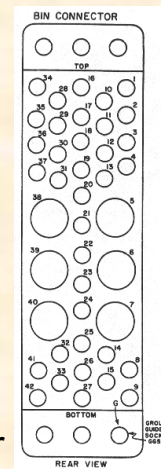

NIM – the next generation

NIM is still very alive
Some examples

100 MS/s
digitizer
with optical
read-out



General
purpose NIM
module with
programmable
logic
(LabView)

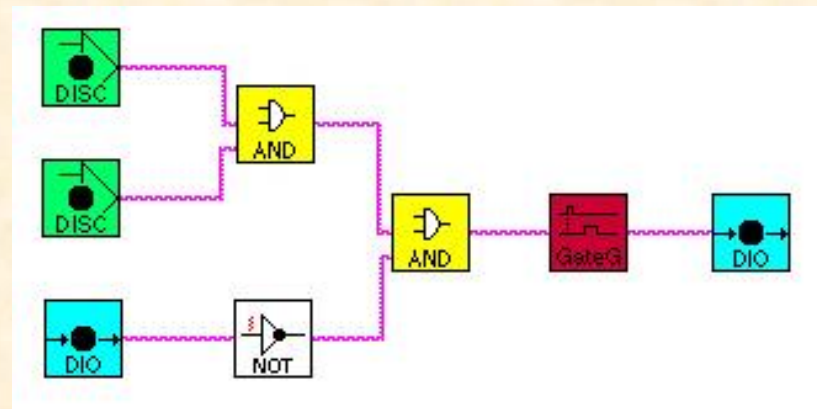

PCI

- First standardized in 1991
- Replaced the older ISA cards
- Initially intended for PC cards
 - Later **spin-offs**: CompactPCI, PXI, PMC 
- Parallel PCI rapidly disappearing -> replaced by serial PCIe

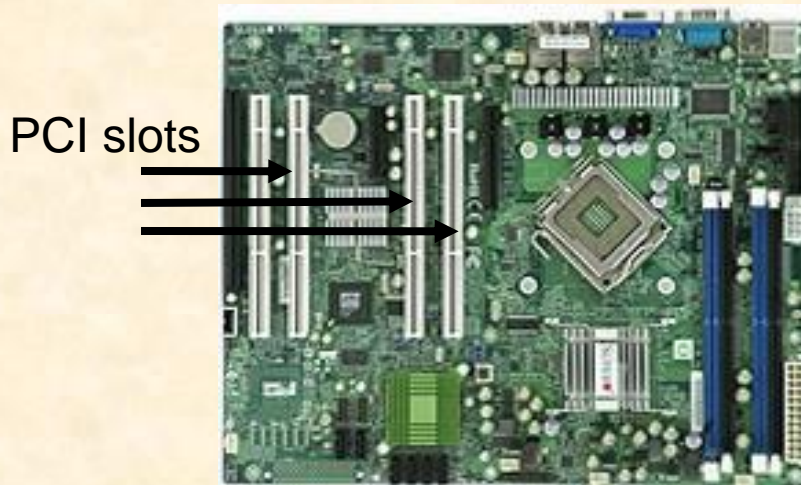

PC motherboard



PCI basics

- Main features of the protocol
 - Synchronous timing
 - But wait cycles possible
 - Clock rates
 - Initially 33 MHz. Later: 66 MHz, (PCI-X: 100 and 133 MHz)
 - Bus width
 - Initially 32 bit. Later: 64 bit
 - Signaling voltage
 - Initially 5 V. Later 3.3 V (->slot keying)
 - Terminology
 - A data transfer takes place between an INITIATOR (master) and a TARGET (slave)
 - Bus topology
 - 1 to 8 (depending on clock rate) slots per bus
 - Busses can be connected to form a tree
 - Address and data as well as most protocol lines are shared by all devices; The lines used for arbitration are connected point-to-point; The routing of the interrupt request lines is more complicated...
 - A system can consist of several Initiators and Targets but only one Initiator can receive interrupts

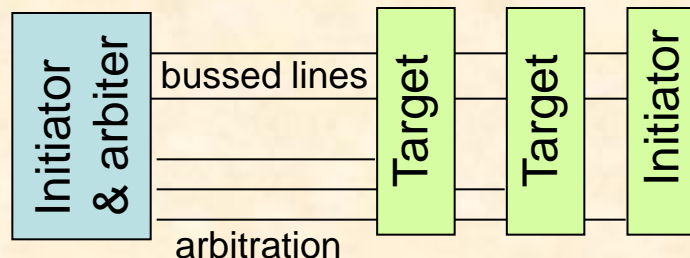

PCI basics - 2

- Address spaces
 - **Configuration space**
 - Standardized registers for the dynamic configuration of the H/W (plug-and play)
 - **I/O space**
 - For device specific registers
 - **MEM space**
 - General purpose space for registers and memory
- **Cycle types** (encoded in the C/BE[3::0]# lines)
 - **Single cycles**
 - Read / write of all 3 address spaces
 - **Bursts**
 - MEM read / write (with special features for cache handling)
- (Typical) performance
 - **Single cycle:** 2 (3 for read) -> ~10 clock cycles
 - 33 MHz / 32 bit: 66 MB/s -> ~10 MB/s
 - 64 MHz / 64 bit: 264 MB/s -> ~40 MB/s
 - **Bursts:**
 - 33 MHz / 32 bit: Max. 132 MB/s
 - 64 MHz / 64 bit: Max. 528 MB/s
 - PCI-X @ 133 MHz: 1.06 GB/s
 - PCI-PCI **bridges** add additional delays

PCI devices under Linux

The command “lspci” displays information about the PCI devices of a computer

Show PCI tree: lspci -t -v

```
-[0000:00]--00.0 Intel Corporation E7520 Memory Controller Hub
  +-00.1 Intel Corporation E7525/E7520 Error Reporting Registers
  +-01.0 Intel Corporation E7520 DMA Controller
  +-02.0-[0000:01-03]---+00.0-[0000:02]----03.0 CERN/ECF/EDU Unknown device 0144
    |
    |   +-00.1 Intel Corporation 6700/6702PXH I/OxAPIC Interrupt Controller A
    |   |
    |   |   +-00.2-[0000:03]----01.0 CERN/ECF/EDU Unknown device 0144
    |   |   |
    |   |   |   \-00.3 Intel Corporation 6700PXH I/OxAPIC Interrupt Controller B
    |   |
    |   +-04.0-[0000:04]----00.0 Broadcom Corporation NetXtreme BCM5721 Gigabit Ethernet PCI Express
    |   +-05.0-[0000:05]----00.0 Broadcom Corporation NetXtreme BCM5721 Gigabit Ethernet PCI Express
    |   +-06.0-[0000:06-08]----00.0-[0000:07-08]---+04.0 Broadcom Corporation NetXtreme BCM5714 Gigabit Ethernet
    |   |
    |   |   +-04.1 Broadcom Corporation NetXtreme BCM5714 Gigabit Ethernet
    |   |   |
    |   |   |   \-08.0-[0000:08]---+06.0 Broadcom Corporation NetXtreme BCM5704 Gigabit Ethernet
    |   |   |
    |   |   |   \-06.1 Broadcom Corporation NetXtreme BCM5704 Gigabit Ethernet
    |   |
    |   +-07.0-[0000:09-0b]---+00.0-[0000:0a]----02.0 CERN/ECF/EDU Unknown device 0144
    |   |
    |   |   +-00.1 Intel Corporation 6700/6702PXH I/OxAPIC Interrupt Controller A
    |   |   |
    |   |   |   +-00.2-[0000:0b]----01.0 CERN/ECF/EDU Unknown device 0144
    |   |   |   |
    |   |   |   |   \-00.3 Intel Corporation 6700PXH I/OxAPIC Interrupt Controller B
    |   |
    |   +-1d.0 Intel Corporation 82801EB/ER (ICH5/ICH5R) USB UHCI Controller #1
    |   +-1d.1 Intel Corporation 82801EB/ER (ICH5/ICH5R) USB UHCI Controller #2
    |   +-1d.2 Intel Corporation 82801EB/ER (ICH5/ICH5R) USB UHCI Controller #3
    |   +-1d.3 Intel Corporation 82801EB/ER (ICH5/ICH5R) USB UHCI Controller #4
    |   +-1d.7 Intel Corporation 82801EB/ER (ICH5/ICH5R) USB2 EHCI Controller
    |   +-1e.0-[0000:0c]----01.0 ATI Technologies Inc Rage XL
    |   +-1f.0 Intel Corporation 82801EB/ER (ICH5/ICH5R) LPC Interface Bridge
    |   \-1f.3 Intel Corporation 82801EB/ER (ICH5/ICH5R) SMBus Controller
```

Show device details: lspci -v -s 02:03.0

```
02:03.0 Co-processor: CERN/ECF/EDU Unknown device 0144 (rev ac)
Subsystem: Unknown device 2151:1087
Flags: bus master, 66MHz, medium devsel, latency 32, IRQ 209
Memory at d7200000 (32-bit, non-prefetchable) [size=512]
I/O ports at 2000 [size=256]
Memory at d8000000 (32-bit, non-prefetchable) [size=16M]
Capabilities: <access denied>
```

PCI protocol

Example: Single cycle read

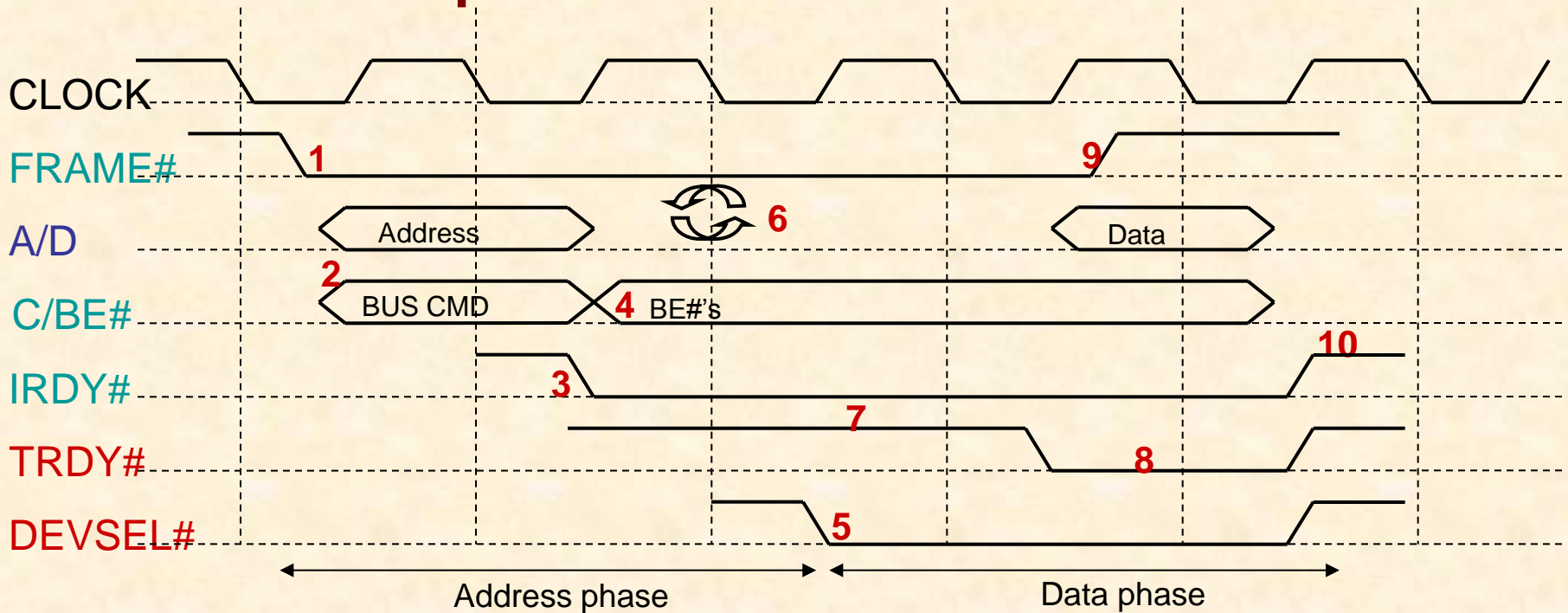

- 1) Assertion of FRAME starts cycle
- 2) Initiator puts address and command (cycle type) on the bus
- 3) The Initiator signals that it is ready to receive data
- 4) The initiator uses the C/BE lines to define which bytes it wants to read
- 5) Target looks at the Address and drives DEVSEL if it was addressed. If no target drives DEVSEL after at most 6 clock the Initiator will abort the cycle
- 6) The ownership of the AD lines changes from Initiator to target (only for read cycles). This requires one clock cycle

- 7) The Target does not yet drive TRDY (it may need time to prepare the data) but asks the Initiator to wait
- 8) The Target has the data ready on the AD lines. The Initiator fetches the data in the same clock cycle
- 9) By de-asserting FRAME the Initiator tells to the Target that it does not want additional data after the next data word
- 10) The cycle is over and the protocol lines get released

Some examples of PCI H/W

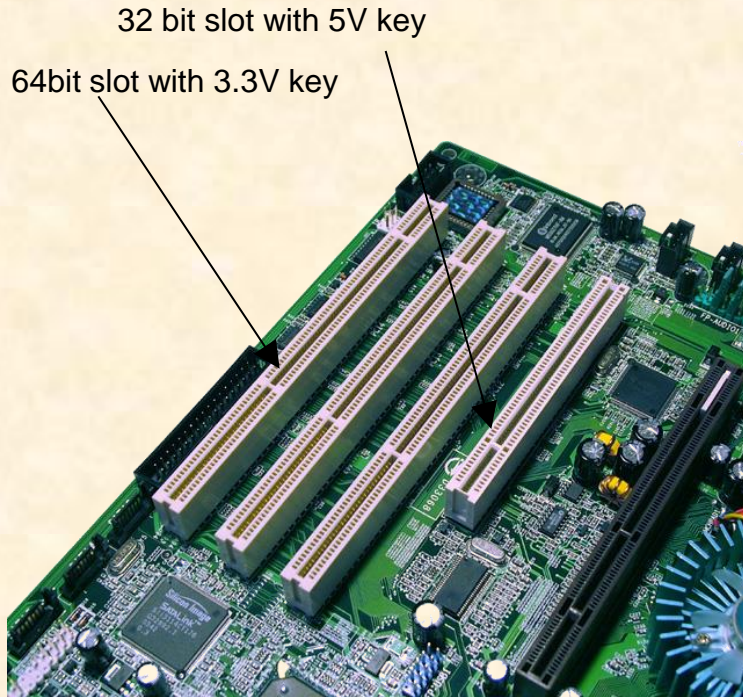

PC motherboard with PCI slots

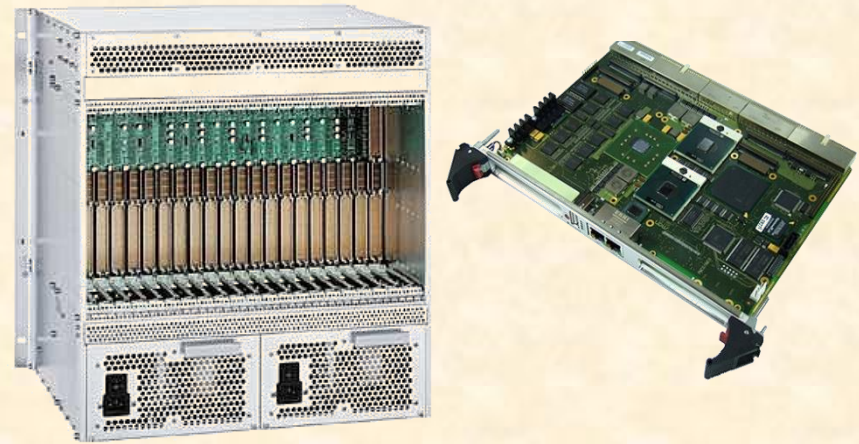

6U CompactPCI chassis and card



PXI system

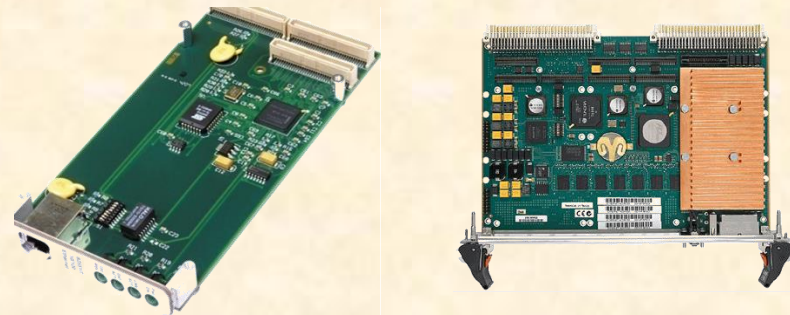

PMC card and carrier (VMEbus)



Parallel bus -> Serial link

Parallel Buses Are Dead! (RT magazine, 2006)

What is wrong about “parallel”?

- You need lots of pins on the chips and wires on the PCBs
- The skew between lines limits the maximum speed

What is wrong about “bus”?

- Speed is a function of the length (impedance) of the lines
- Communication is limited to one master/slave pair at a time (no scalability)
- The handshake may slow down the maximum speed

All parallel buses are dead. All? No!

- There is lots of legacy equipment
- VMEbus is still used heavily (military / research)
- PCs still support parallel PCI (but this will change)

What next?

- Switched serial interconnects



(Switched) serial links

- Standards (just the most important)

- PCIe
- 1 / 10 GB Ethernet
- Serial RapidIO
- Infiniband 
- Serial ATA
- FiberChannel
-

- Commonalities

- Signal rate: 2.5 – 10 GHz
- Packet switching
- Topology

- Star: Devices connect to a fabric switch
 - Dual Star: Devices connect to two fabric switches (for redundancy)
- Mesh: All devices have direct links to all others

- Differences

- Support for interrupts
- Support for programmed I/O
- Quality of service (guaranteed bandwidth)

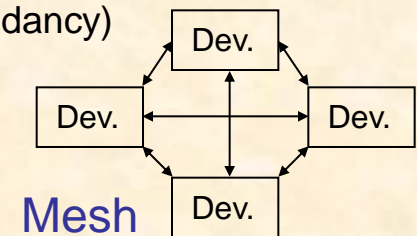
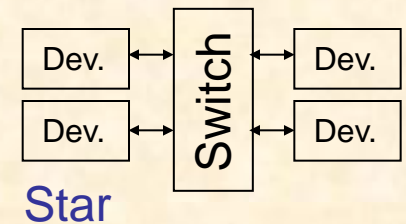

Infiniband

- Developed by Compaq, IBM, Hewlett-Packard, Intel, Microsoft and Sun from 1999 onwards
- Characteristics
 - Bi-directional serial link
 - Aggregation of links (4x, 12x possible)
 - Link speed: 2.5, 5, 10 GHz
 - Special features
 - Data transfer performed without involvement of OS (latency < 2 μ s)
 - Remote DMA (fetch data from the memory of a remote system)
 - Main field of application
 - Server and storage interconnect for high performance computing
 - Relevance for DAQ
 - Limited for a lack of DAQ products

Serial Rapid I/O

- Developed by Mercury Computer Systems and Motorola from 1997 onwards
- Characteristics
 - Bi-directional serial link
 - Aggregation of links (2x, 4x, 8x, 16x possible)
 - Link speed: 1.25, 2.5, 3.125, 5, 6.25 GHz
 - Special features
 - Quality of Service (transfer requests can be prioritized)
 - Multicast
 - Main field of application
 - Chip/chip and board/board communication
 - Relevance for DAQ
 - Limited for a lack of DAQ products but some AMC/ATCA products



PCIe (aka PCI Express)

- Not a bus any more but a point-to-point link
- Data not transferred on parallel **lines** but on one or several serial **lanes**
 - **Lane**: One pair of LVDS lines per direction
 - Clock rate: 2.5 GHz (PCIe2.0: 5 GHz, PCIe 3.0: 8 GHz, PCIe 4.0-draft: 16 GHz)
 - 8b/10b encoding (PCIe3.0: 128/130b encoding)
 - 250 MB/s (PCIe 1.0) raw transfer rate per lane
 - Devices can support up to 32 lanes
- Protocol at the link layer has nothing to do with protocol of parallel PCI
- Fully transparent at the S/W layer

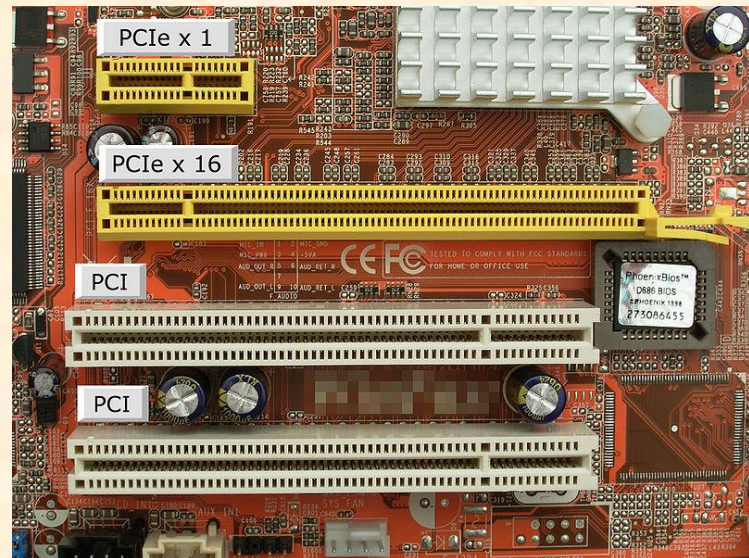
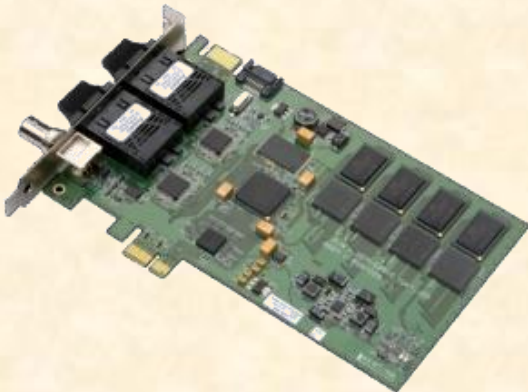

PCIe performance

- Data is transferred in **frames**:

Start 1 byte	Sequence 2 bytes	Header 12 or 16 bytes	Payload 0 - 4096 bytes	ECRC 4 bytes	LCRC 4 bytes	End 1 byte
-----------------	---------------------	--------------------------	---------------------------	-----------------	-----------------	---------------

- **Note:**

- H/W may limit **max payload size** (typically 128, 256 or 512 bytes)
 - Every data packet has to be **acknowledged** (additional overhead)
 - **Read** transactions may cause additional delays
- The actual performance may be as low as **~15%** of the theoretical maximum
 - Achieving more than **~80%** link efficiency is difficult
- The **topology** of the system (PC motherboard) matters as well
 - You may have to use process / thread **affinity** in order to tie your I/O code to the CPU that connects directly to your I/O cards

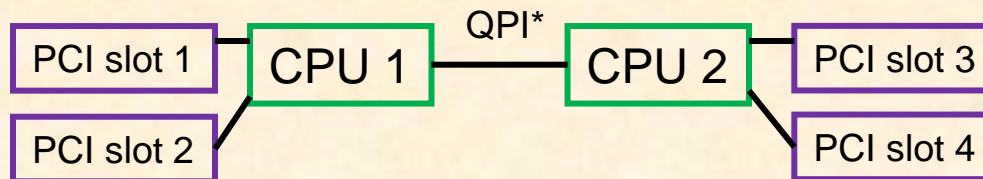

PICMG 1.3 – The basic idea

- A desk-top PC has at most **7 slots** for PCI(e) cards
- PC **motherboards** are **quickly** getting **obsolete**
 - Let's design a standard that is more adapted for using PCI cards in an **industrial domain**
 - Modularize system by decoupling computing core from PCI card backplane

PICMG 1.3 – SHB Express

- **SHB Express** = **System Host Board** standard for **PCIe**
- Standardized in 2005
- Defined in the standard
 - SHB board mechanics (two board formats)
 - PCI interface between SHB and backplane
 - Additional I/O (SATA, USB, Ethernet, etc.) that may be routed to the backplane
 - Backplane design rules
- Systems consist of:
 - One SHB
 - One backplane
 - One or several PCIe, PCI-X or PCI cards

The SHB

- Two (A & B) or 4 (A, B, C & D) connectors
 - Connector A: PCIe
 - (1 x16) or (2 x8) or (1 x8 + 2 x4) or (4 x4)
 - Connector B: PCIe
 - (1 x4) or (4 x1)
 - Connector C:
 - Additional I/O
 - Connector D:
 - 1 32bit PCI(-X)

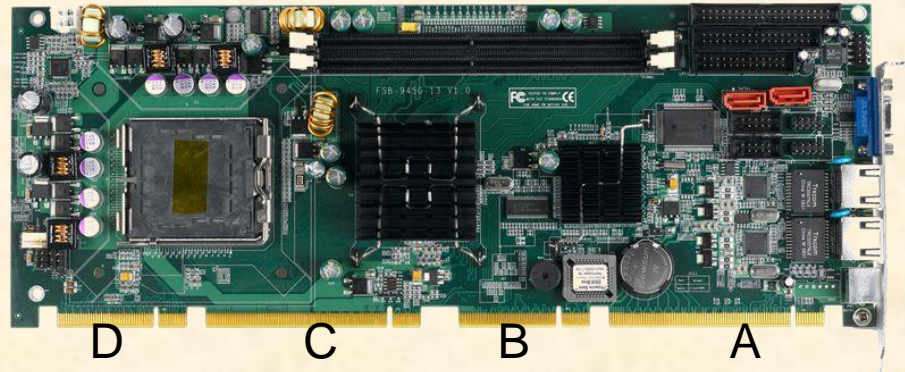

SHB – the backplanes

The backplane has to match the PCIe configuration of the SHB

- x16 on connector A: graphics class
- 2 x8 on Connector A: server class



Segmented backplane with 4 SHB and 12 PCIe slots for a 19" 4U chassis

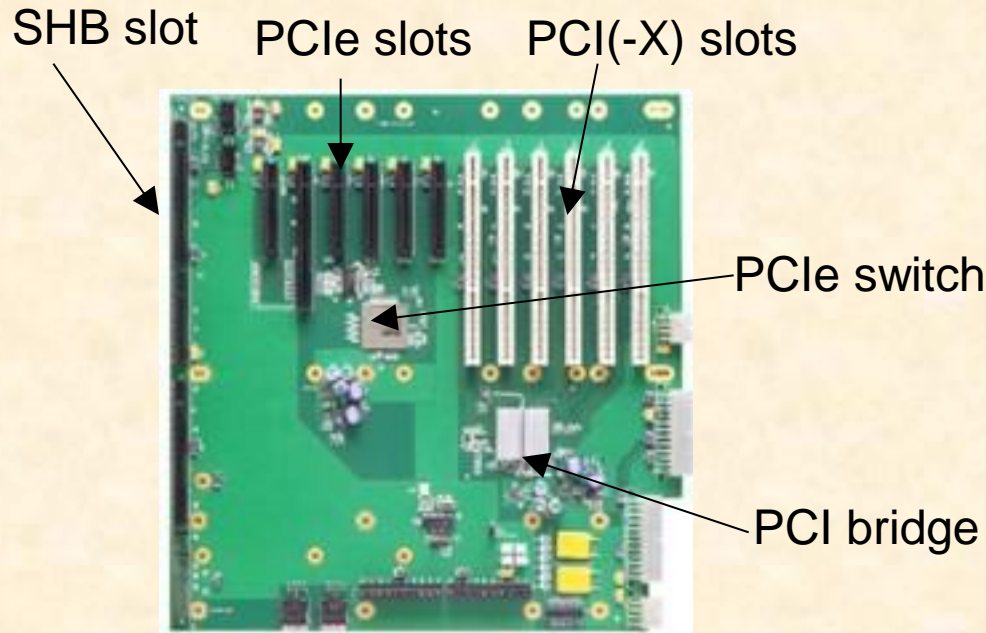

A complete 4U system

The next generation

What new standards are available?

- **VITA41**: VXS
- **PICMG 3.x**: ATCA (Advanced Telecommunications Computing Architecture)
- **PICMG MTCA.x**: MicroTCA/ μ TCA
- **PICMG AMC.x**: Advanced Mezzanine Card (for ATCA and μ TCA)

Not covered in this talk:

- **VITA46**: VPX
- **PICMG 2.x**: Compact PCI (cPCI)
- **PICMG EXP.0**: PCIe for cPCI
- **PCIMG CPCI-S.0**: CompactPCI serial
- **PICMG ATCA300.0**: ATCA for 300mm deep systems (no rear I/O)
- And many more...

PICMG:	www.picmg.org
PCI-SIG:	www.pcisig.com
VITA:	www.vita.com

VXS – The basic idea

- VMEbus **mechanics** is not so bad:
 - Let's keep it
- There is a lot of **legacy equipment**:
 - Let's re-use it
- The data transfer bandwidth could be better:
 - Let's add an optional **high-speed communication** channel

VXS- Components



VMEbus crate

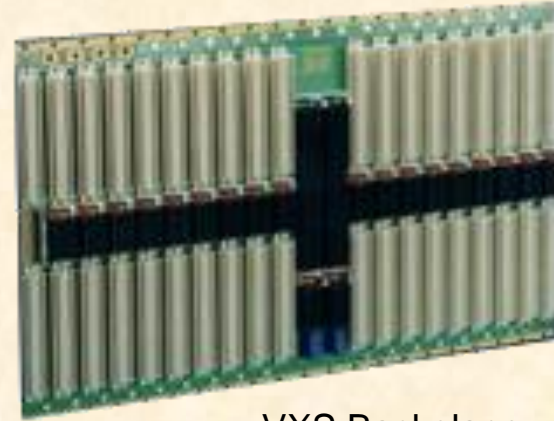

VXS Backplane

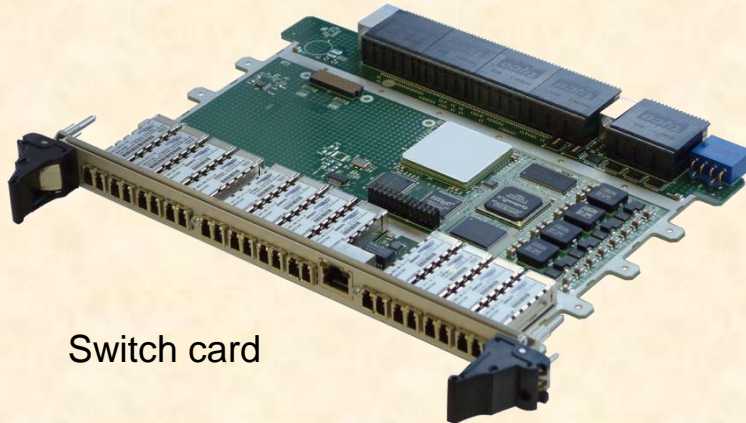

Switch card



Payload card

VXS (VITA 41, ~100 pages)

- Essentially 6U (but 9U not excluded) **VMEbus with a new P0 connector**
- Two types of cards
 - **Payload**
 - **Switch** (one card required, second for redundancy)
- Network topology: (dual) star
- Connectivity for payload cards
 - **16 differential** pairs (10 GHz) defined by the standard (and routed to switch cards)
 - **31 reserved pins** available on P0
- Sub-standards
 - 41.1: Infiniband
 - 41.2: Serial RapidIO
 - 41.3: IEEE Std 802.3 (1000 Mb/s Ethernet)
 - 41.4: PCIe
- Hot Swap: According to VITA 1.4
- System management based on **I²C / IPMI** but only formulated as recommendation

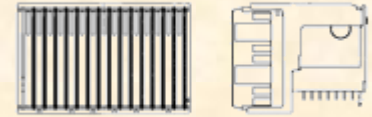

VXS connector



Switch card



Payload card

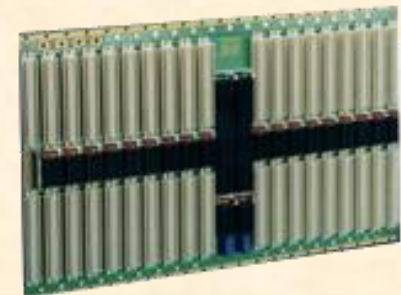

Backplane

WARNING: limited popularity in HEP applications

Advanced TCA – the basic idea

- Telecom companies are using proprietary electronics:
 - Let's design a standard for them from scratch
 - It has to have all the features telecom companies need:
 - High availability (99.999%)
 - Redundancy at all levels
 - Very high data throughput
 - Sophisticated remote monitoring and control

Advanced TCA - Components

Shelves



Shelf manager(s)

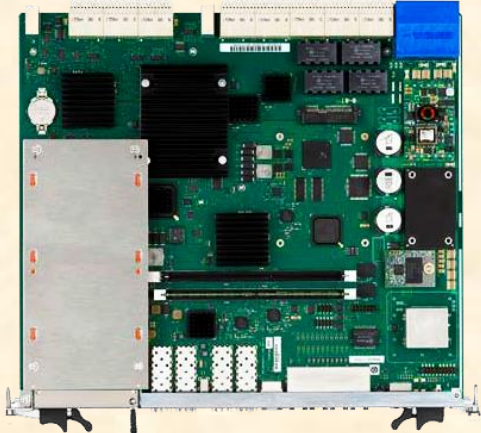

Switch blade

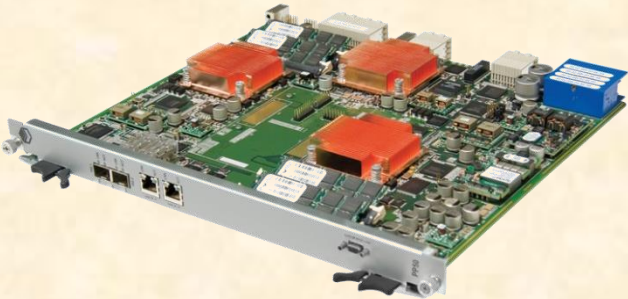

Payload card

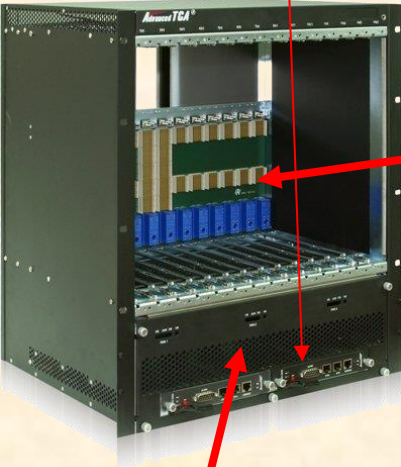

Backplane

Hot-swap fans



AMC carrier

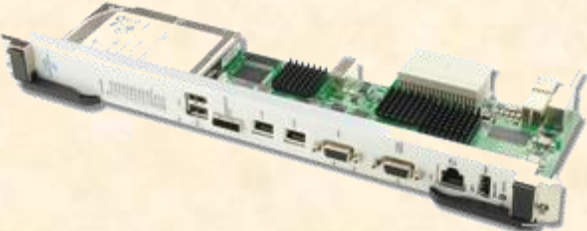

Rear Transition Module

Advanced TCA (650 pages + IPMI)

- More of a system than a board standard
- Started in **2001** by ~100 companies
- **One form factor**
 - Front: 8U x 280 mm x 30.48 mm (14 slots per 19" crate)
 - Rear: 8U x 60 mm (**5W**)
- Supply voltage: **-48 V** (-> DC-DC conversion each on-board)
- Power limit: **200 W** (400-600 W) per card
- Connectors
 - Zone 1: One connector for power & system management
 - Zone 2: One to five ZD connectors for data transfer
 - Zone 3: User defined connector for rear I/O
- Connectivity
 - Up to **200 differential pairs**
 - **4 groups**
 - 64 pairs for Base Interface (usually Eth., star topology)
 - 120 pairs for Fabric Interface (star or full mesh)
 - Ethernet, PCIe, Infiniband, serial RapidIO, StarFabric
 - 6 pairs for Clock Synchronization
 - 10 pairs for Update Channel
- System management based on **IPMI, I²C and FRU data**

**Very trendy!
(and very complex)**

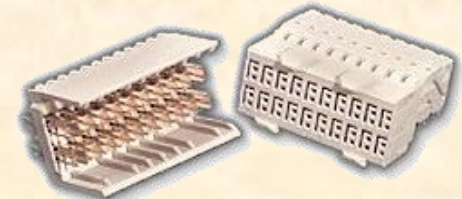

ATCA signal connector

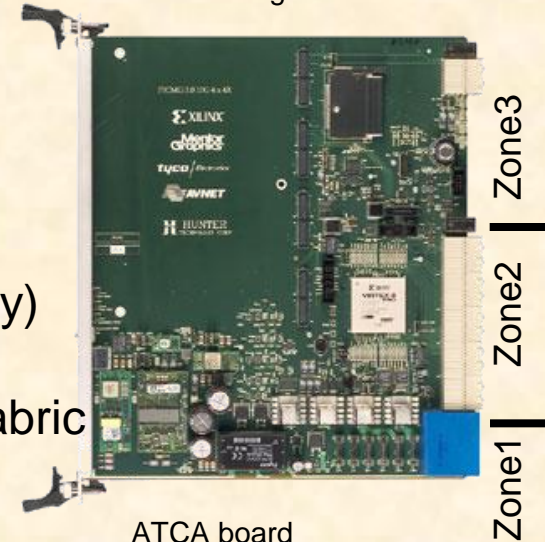

ATCA board

ATCA HA features

(applies also largely to μ TCA)

Redundancy

- Power Supply modules
- Ventilators
- Shelf managers
- Switch blades

Electronic Keying

- Based on FRU information payload cards may be accepted / rejected in a given slot

Hot swap

- Payload board will only receive (payload) power if the shelf manager can guaranty for the availability of the required resources (power, cooling, signal connections)

Monitoring

- Low level: IPMI on I²C
- High level: SNMP (Simple Network Management Protocol) and other protocols on top of TCP/IP
- System event logs

Cooling

- Dynamically controlled fans and several alarm levels

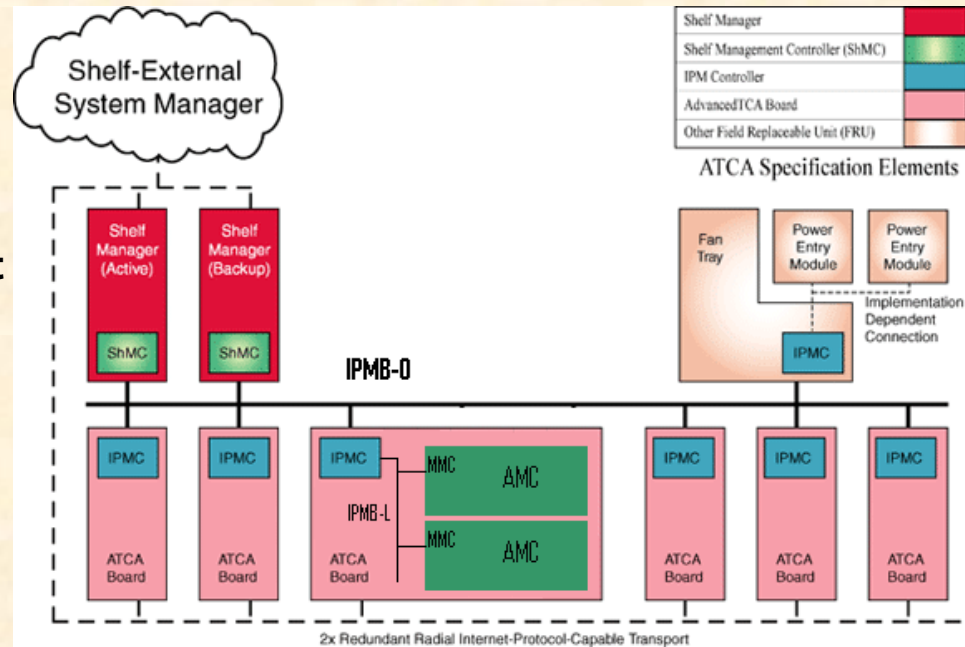

Dedicated tree for control and monitoring

AMC – The basic idea

- **ATCA blades** are **big**. Small **mezzanine** modules could be helpful to modularize their functionality
- PMC/XMC mezzanines are not **hot-swappable**
 - Let's design a new type of mezzanine for ATCA

AMC

- Originally intended as **hot-swappable** mezzanine standard for ATCA but soon used as the basis for the μ TCA standard
- 6 form factors:
 - 74 or 149 mm **wide**
 - 13, 18 or 28 mm **high**
 - 180 mm **deep**
- Power supply: **80W** (max) on **+12V** (and 0.5W on 3.3V management power)
- Connector: 85 pin (single sided) or 170 pin (double sided) edge connector
- Connectivity
 - Up to **12.5 Gb/s**
 - **20+20 LVDS signal pairs** for data transfer (Eth, PCIe, SAS/SATA, Serial RapidIO)
 - Clock interface, JTAG
- Managed via local microcontroller (**MMC**)
 - **IPMI** messages on I²C

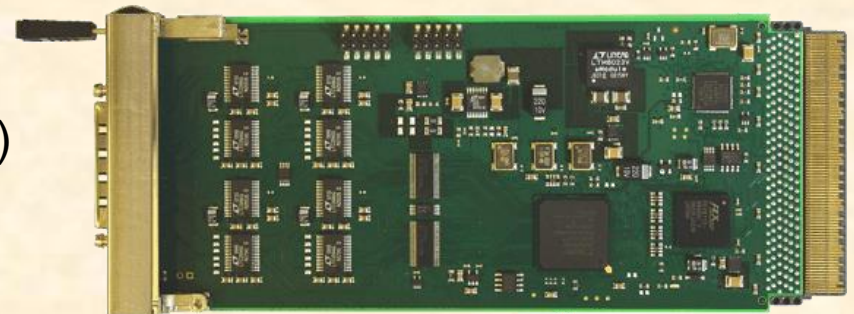
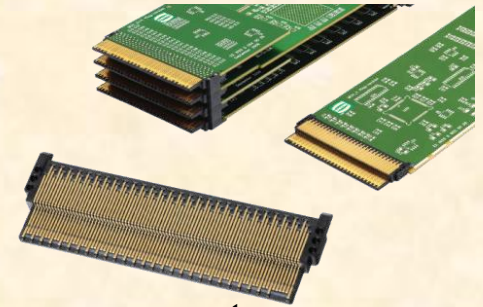

μ TCA – The basic idea

- AMC mezzanines are great but ATCA is a heavy standard and the H/W is expensive
 - Let's define a standard that allows for **using AMCs directly in a shelf** (i.e. Promote the AMC from “mezzanine” to “module”)

μ TCA - Components

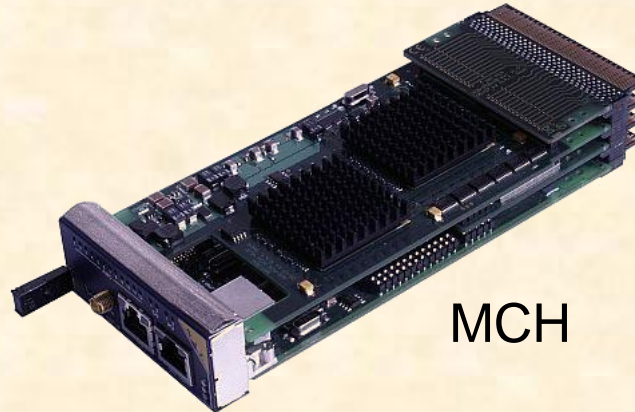

MCH



Shelves



AMCs

μTCA

Very trendy!
(watch out for interoperability issues)

- A system standard based on the AMC, standardized in 2006
- Min. signaling speed: 3.125 GHz
- Connectivity:
 - 4 AMC LVDS pairs defined as “Common Options” (2 Eth. & 2 SAS ports) and connect to 1 or 2 MCH boards which provide the switching
 - 8 AMC LVDS pairs defined as (extended) fat pipes (1 or 10 G Eth, PCIe, RapidI/O). Connection to MCH not standardized
 - Remaining 8 LVDS pairs not defined (can be used for rear I/O (but rear I/O not foreseen in uTCA standard))
- System management based on IPMI / I²C
- Hot-swap support for PSU & cooling
- Redundant MCH (μTCA Controller Hub)
- The MCH connector supports up to 84 differential pairs. Therefore only 7 pairs per AMC (based on a 12-slot backplane) can be routed to the switch.

Connector Region	AMC Port #	Signal Conventions				MCH Fabric #
Common Options	0	AMC.2 1000Base-BX				A
	1	AMC.2 1000Base-BX				2/A
	2	AMC.3 SAS				B
	3	AMC.3 SAS				2/B
Fat Pipes	4	AMC.1 x4 PCI-E	AMC.4 x4 SRIO	AMC.2 1000Base-BX	AMC.2 10GBase-BX4	D
	5			AMC.2 1000Base-BX		E
	6			AMC.2 1000Base-BX		F
	7			AMC.2 1000Base-BX		G
Extended Fat Pipes	8	AMC.4 x4 SRIO	AMC.2 1000Base-BX	AMC.2 1000Base-BX	AMC.2 10GBase-BX4	2/D
	9			AMC.2 1000Base-BX		2/E
	10			AMC.2 1000Base-BX		2/F
	11			AMC.2 1000Base-BX		2/G



xTCA degrees of freedom (not necessarily a complete list)

- ATCA

- Communication protocol(s) on the fabric channels
- Routing of the fabric channels on the backplane (network topology)
- Connection between front board and RTM
- Degree of redundancy
- Power supply at shelf level (230 VAC or -48 VDC)

- AMC

- Card height (13, 18 & 28 mm)
- Card width (74 & 149 mm)
- Communication protocols (currently 4 options)
- Number of pins on the connector (85 or 170)
- JTAG support

- uTCA

- AMC height & width
- Degree of redundancy (MCH, PSU, cooling)
- Routing of the fabric channels on the backplane (custom backplanes)
- JTAG support
- Connectivity of MCH to backplane (1 to 4 tongues) and type of communication protocol on the fat pipes
- Rear transition modules (MTCA.4)

xTCA issues

- The operation of an xTCA system requires a complex, standard compliant S/W infrastructure
 - Efforts to provide **open source management S/W for xTCA**: OpenSAF, SAForum
- As many features of the standard(s) are optional, products from different vendors may not be compatible
 - Efforts to insure **interoperability of xTCA products**: CP-TA, SCOPE alliance
- Many vendors seem to be in favour of “**profiles**” that limit the number of options given by the standards
 - ATCA profile for telecommunication
 - Proposal for a “**physics profile**” for xTCA
- The market does not yet provide lots of **front end modules** for physics DAQ
- There is little information available about the **system performance** (end to end H/W performance and S/W overhead) of the data transfer links

Mezzanines

A “module” is not necessarily monolithic. Often it carries mezzanines

Use mezzanines to:

- Improve maintainability (mezzanines are easy to replace)
- Implement general purpose functions (e.g. controller, ADC, DC/DC)

- Some popular mezzanine standards

- **PMC** (IEEE P1386.1)
 - Relatively old PCI based standards for VMEbus, CompactPCI, etc.
- **XMC** (VITA 42)
 - PMC with additional high speed interface (e.g. PCIe)
- **FMC** (VITA 57)
 - Small mezzanine for FPGA based designs



PMC



FMC



XMC

What is the right standard for me?

- This obviously **depends on your requirements**
 - **Bandwidth & latency**
 - Availability of **commercial products** (front end)
 - **Existing infrastructure** (S/W and H/W) and expertise in your experiment
 - **Start and duration** of the experiment
 - **Scalability** requirements
- **Trends in HEP**
 - LHC & experiments @ CERN: Still VMEbus & PCI based
 - CMS: Several μ TCA systems
 - ATLAS: ATCA proposed as VMEbus replacement, many R&D projects
 - LHCb: ATCA for upgrade program, several projects (but PCs considered as well)
 - LHC: μ TCA for (non LHC) machine control under discussion
 - XFEL @ DESY and SCLS @ SLAC: control system in μ TCA
 - COMPASS @ CERN: VXS derivative