

Preliminary Observations from the V3 test

Torsten, Tobias, Rama, Pierre, Mathieu, Maria, Antoine, Alick
3 October 2013

Crab cavity test: Preliminary results

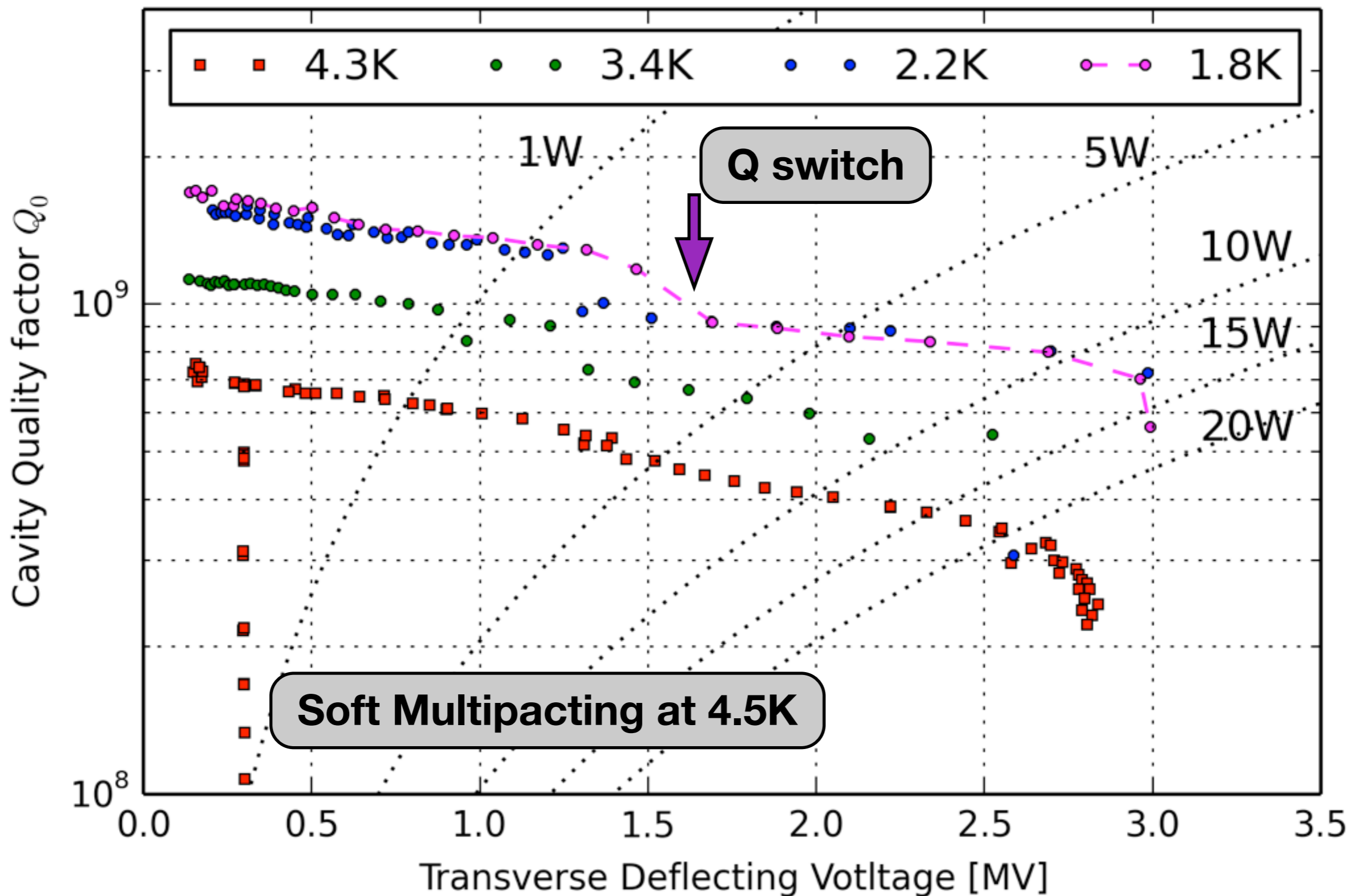

Crab cavity test: Preliminary results

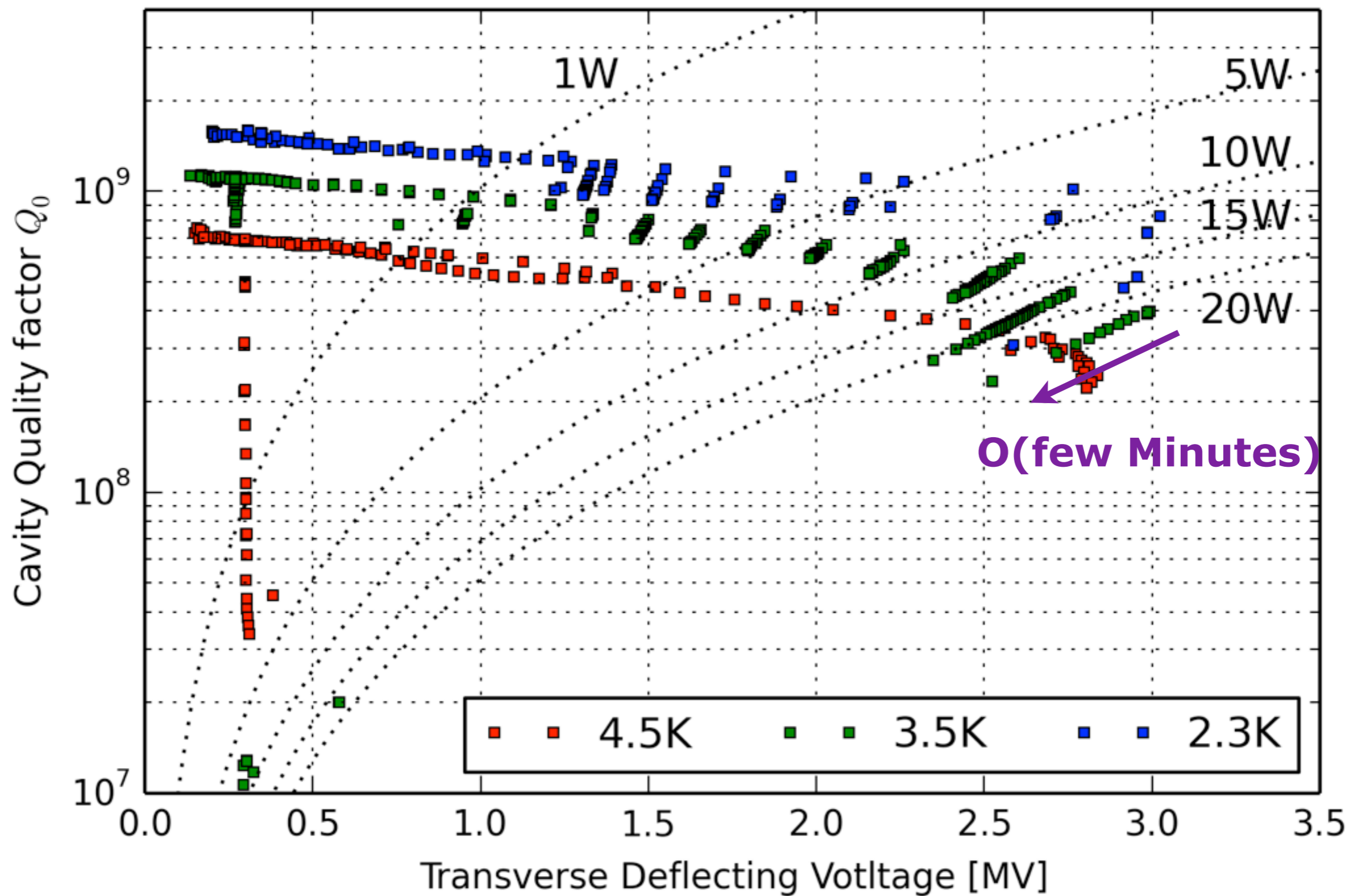

Crab cavity test: Preliminary results

Residual Resistance

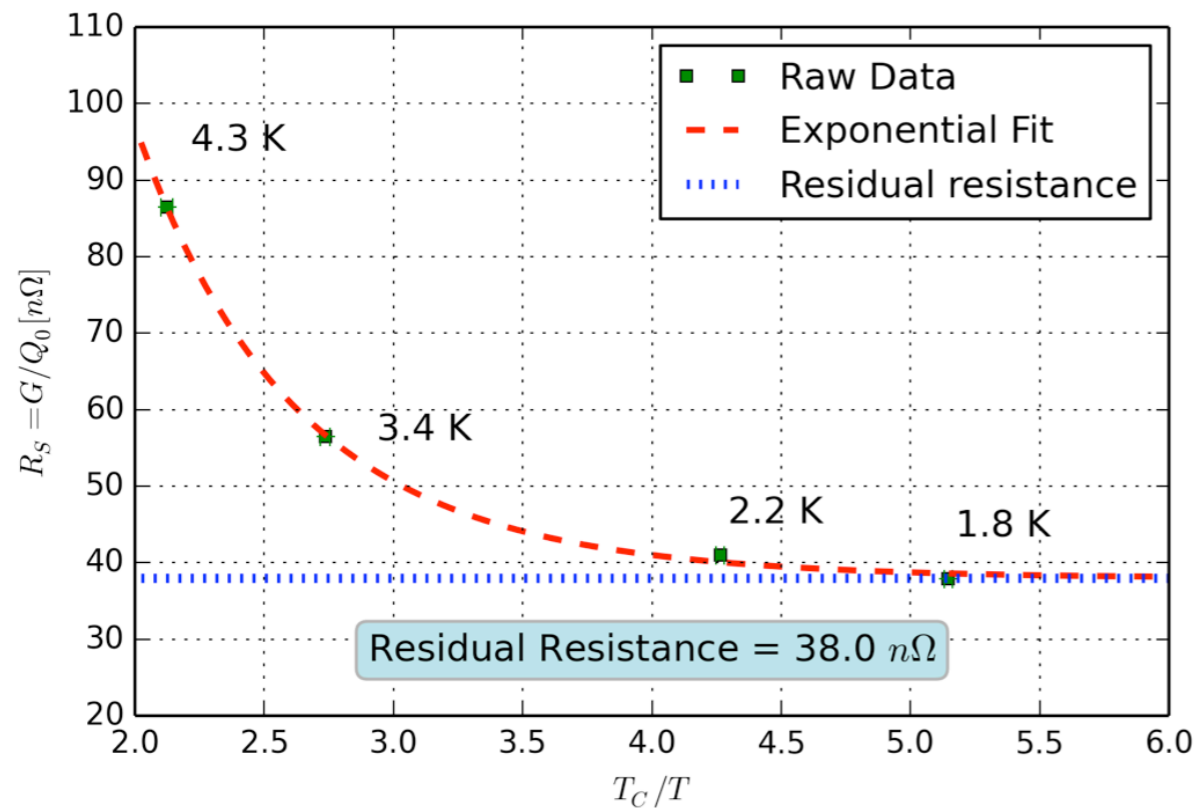

Attempt at RRR

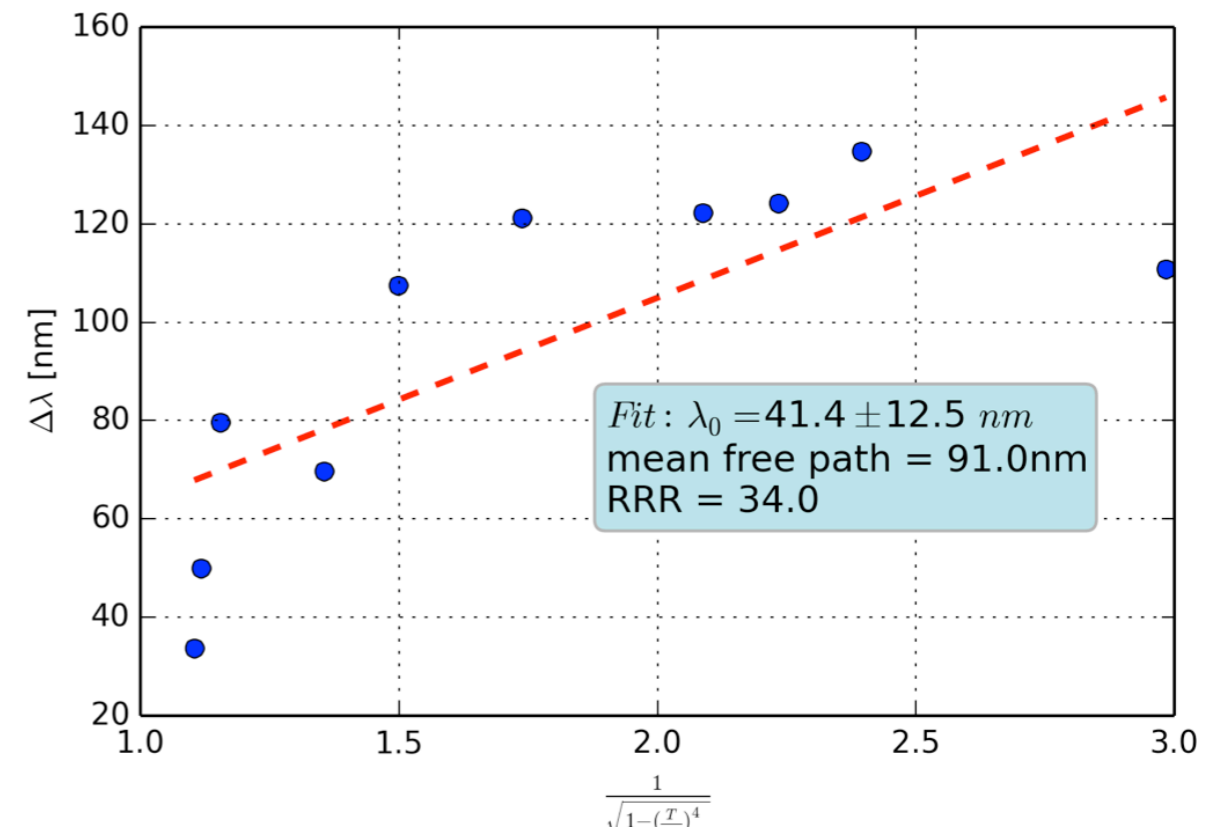

Magnetization

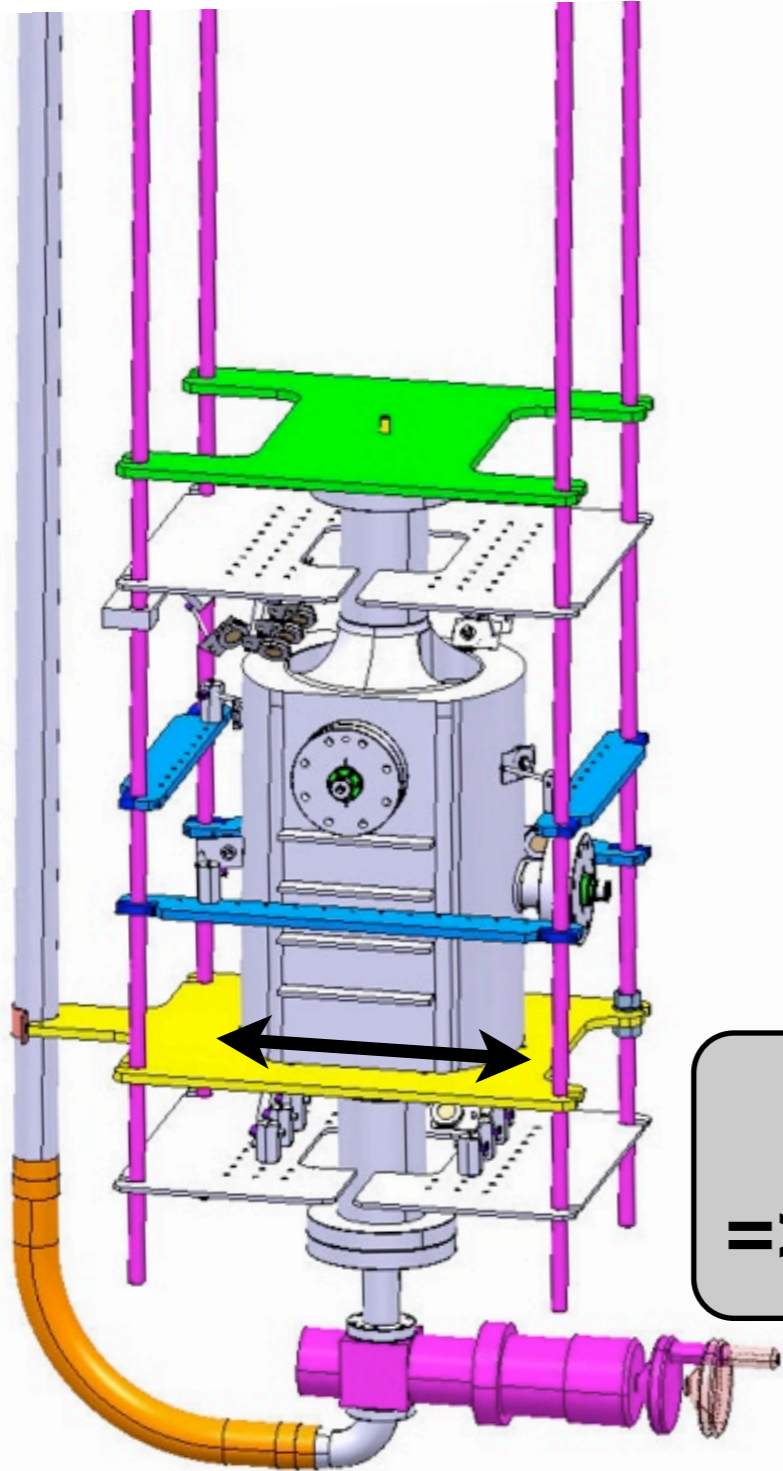

$\sim 10\mu\text{T}$
 $\Rightarrow O(10-20 \text{ n}\Omega)$



Cavity Shape issues

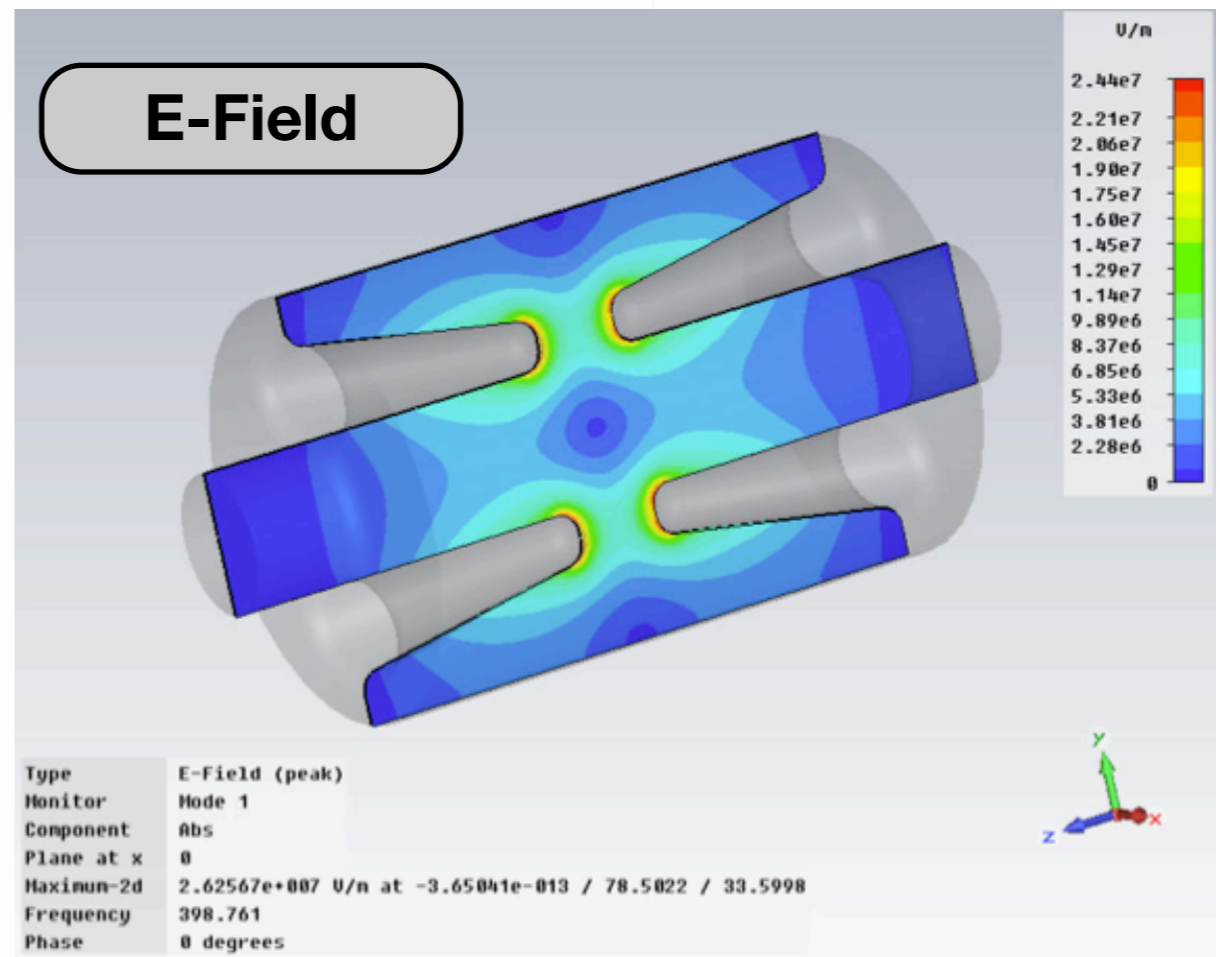
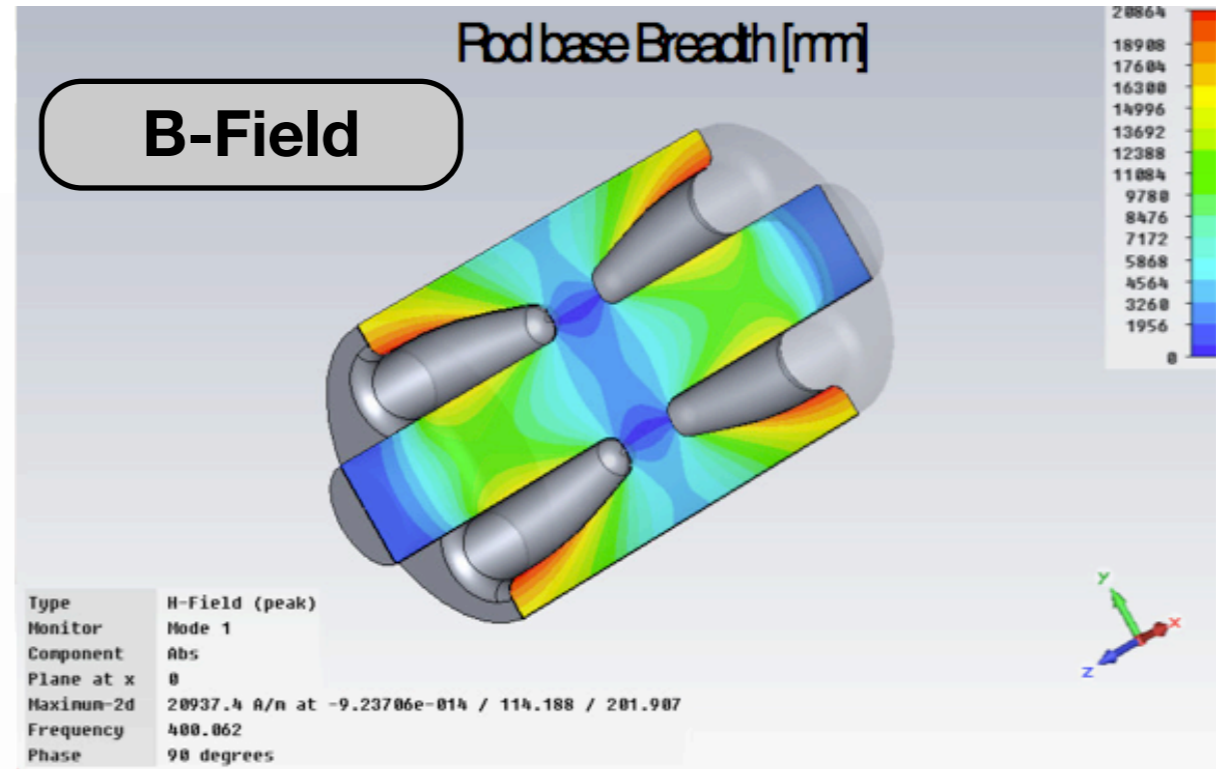
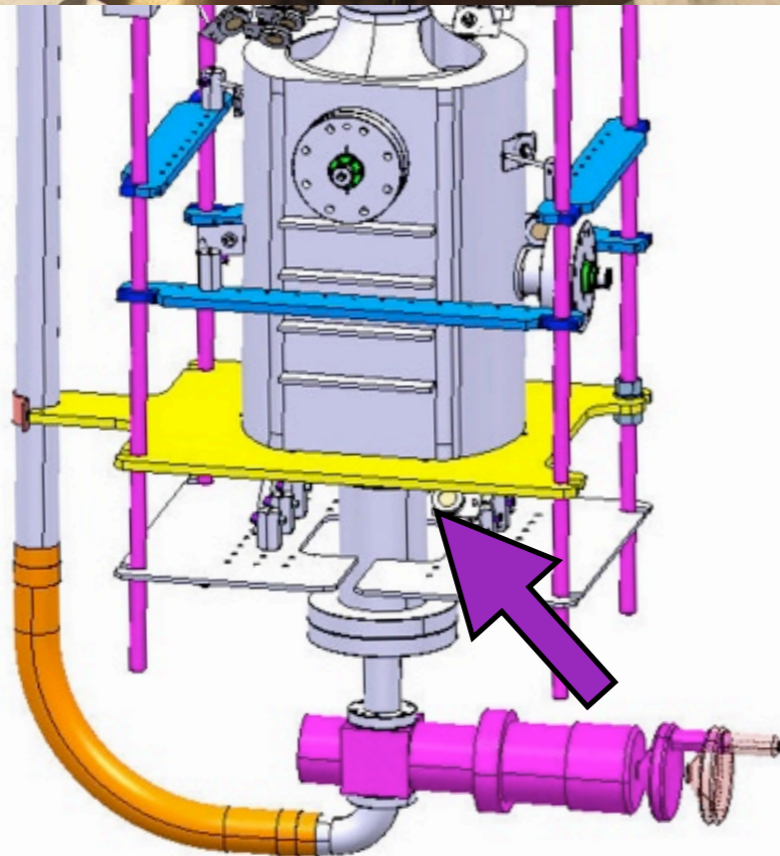
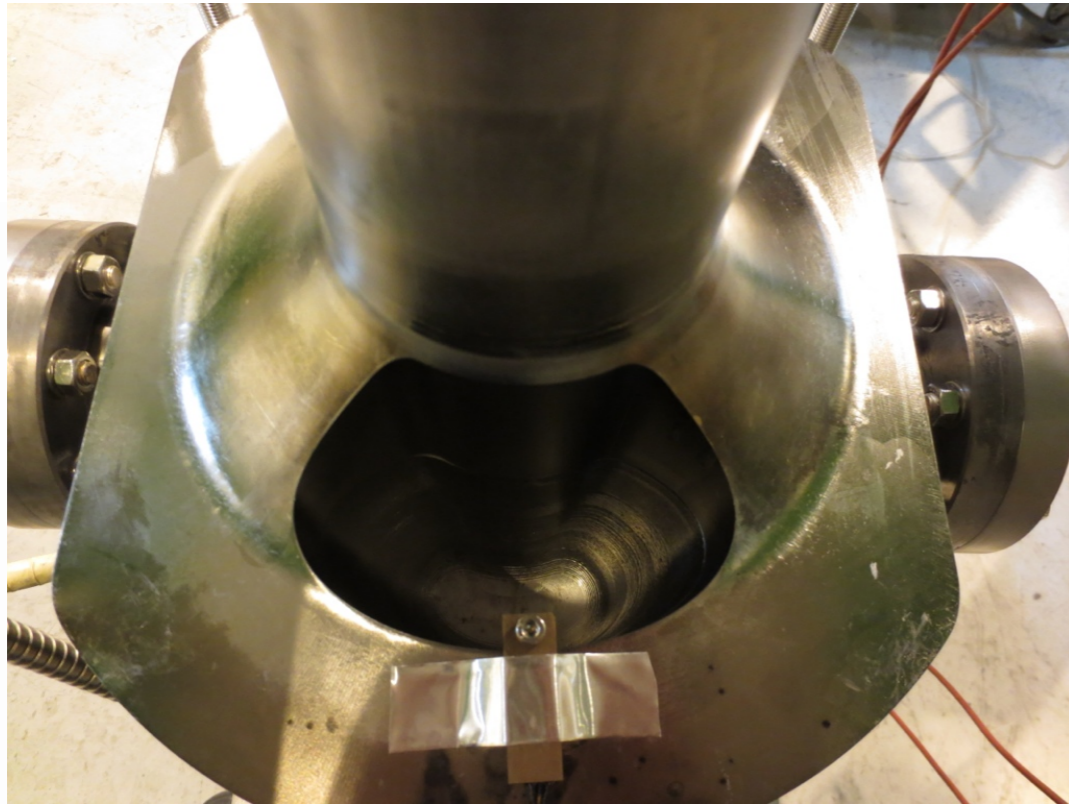

Calibration: P_T response to square pulse

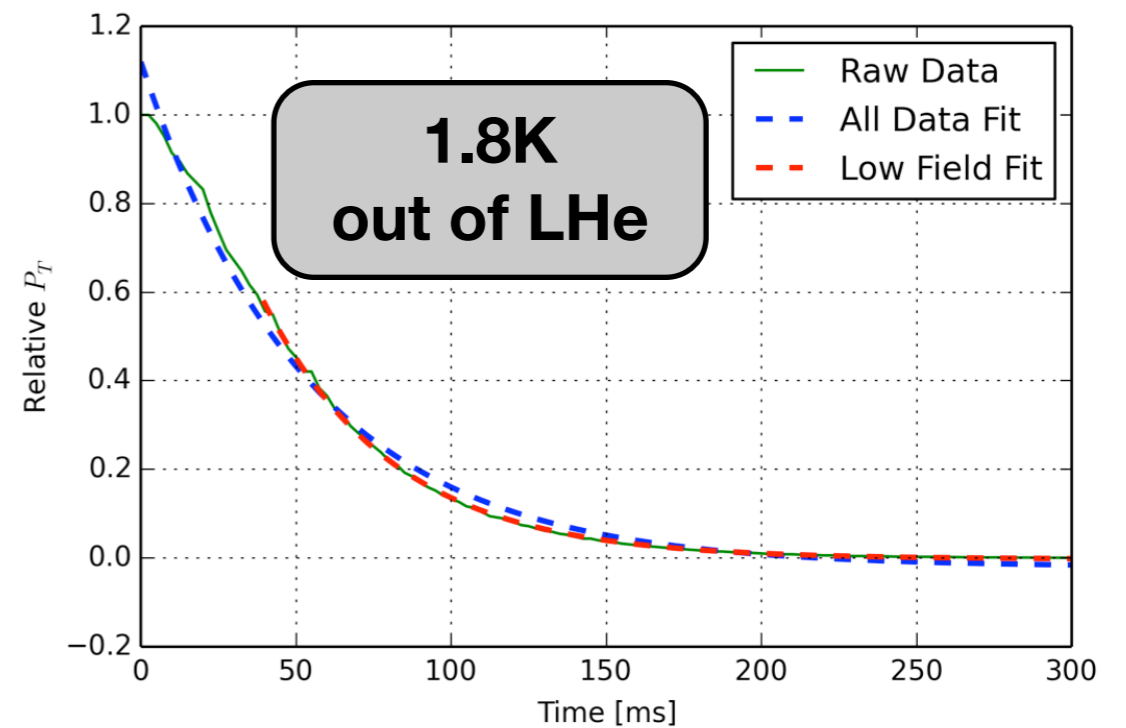
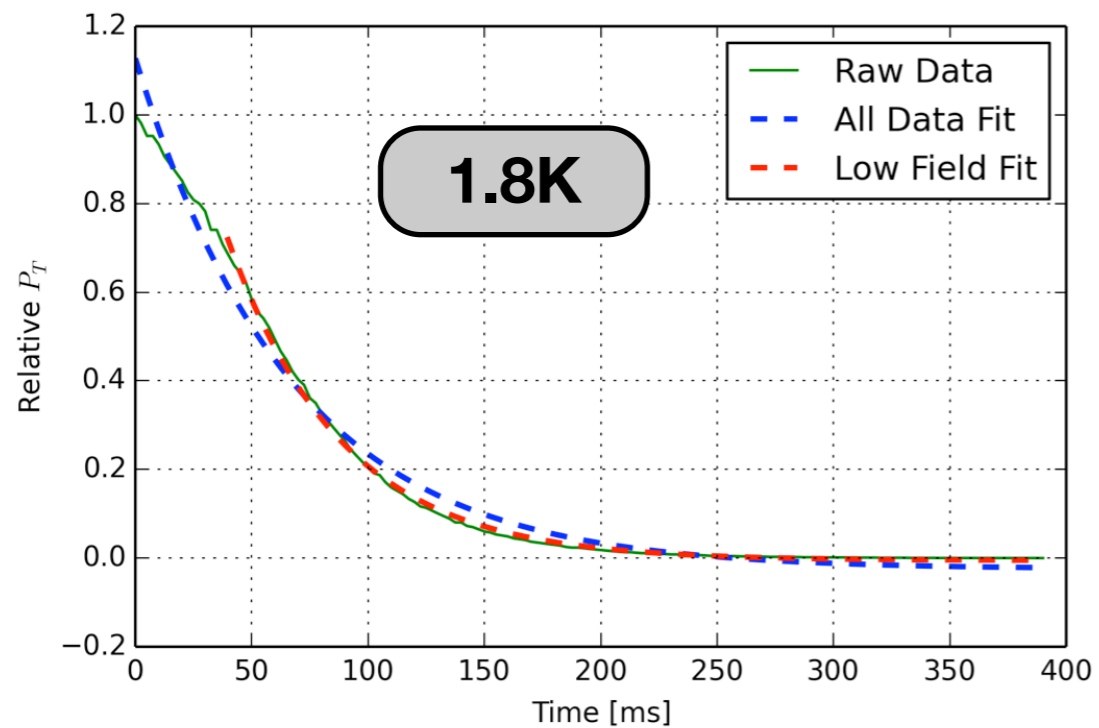
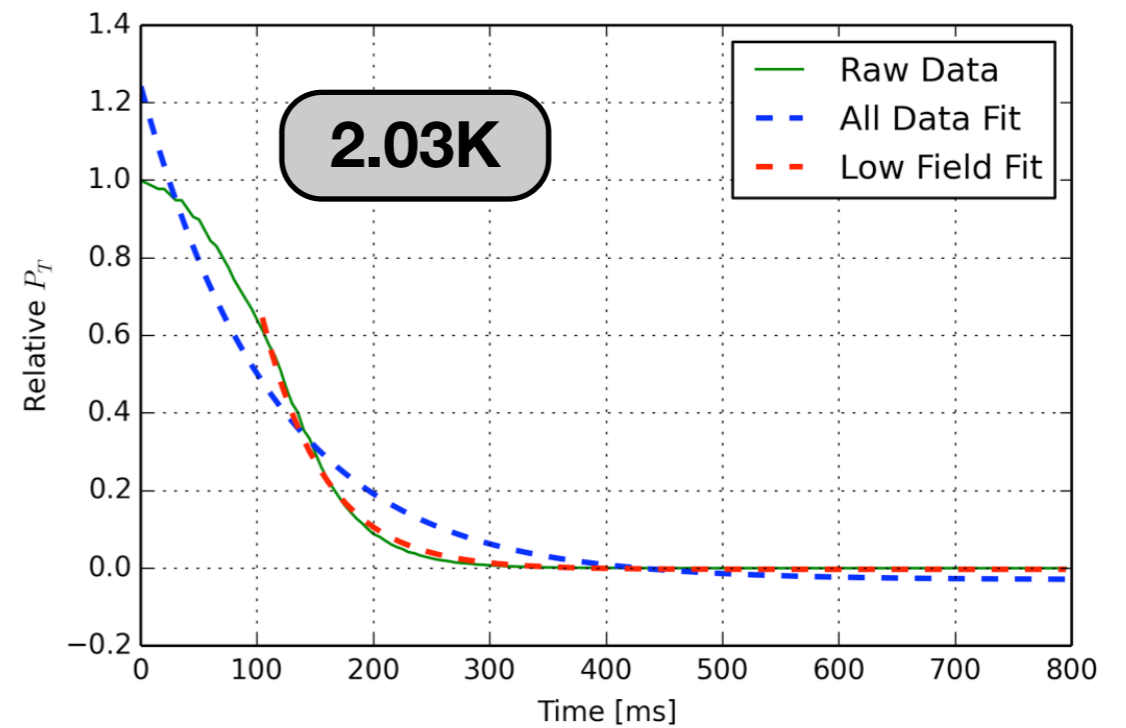
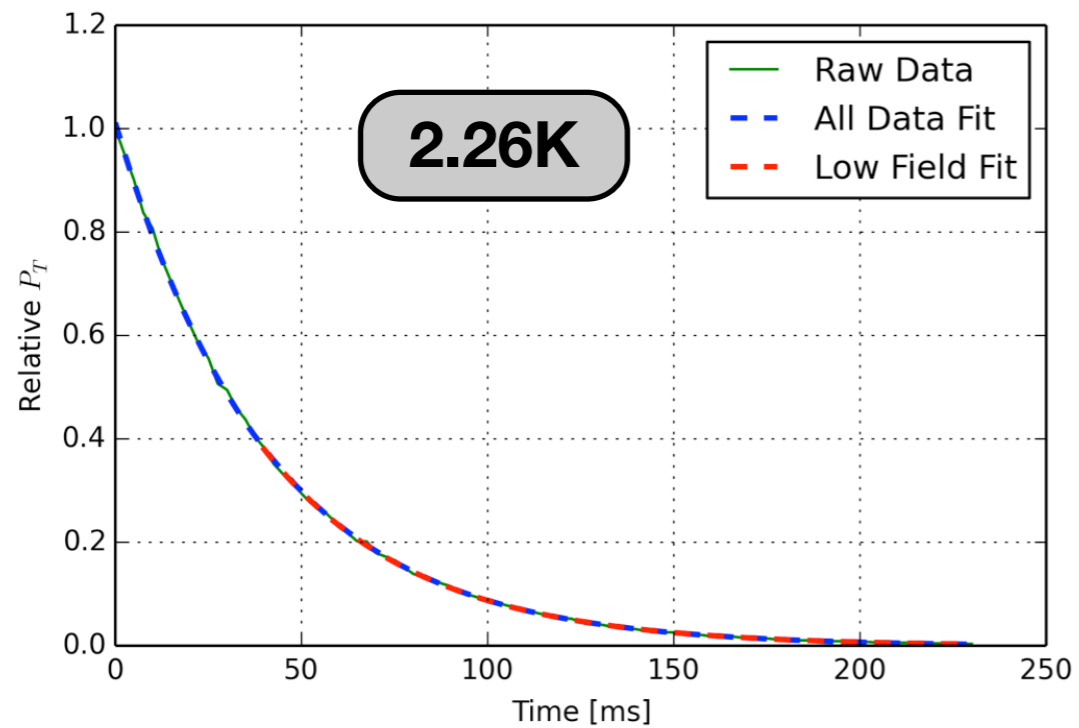

Temperature monitors

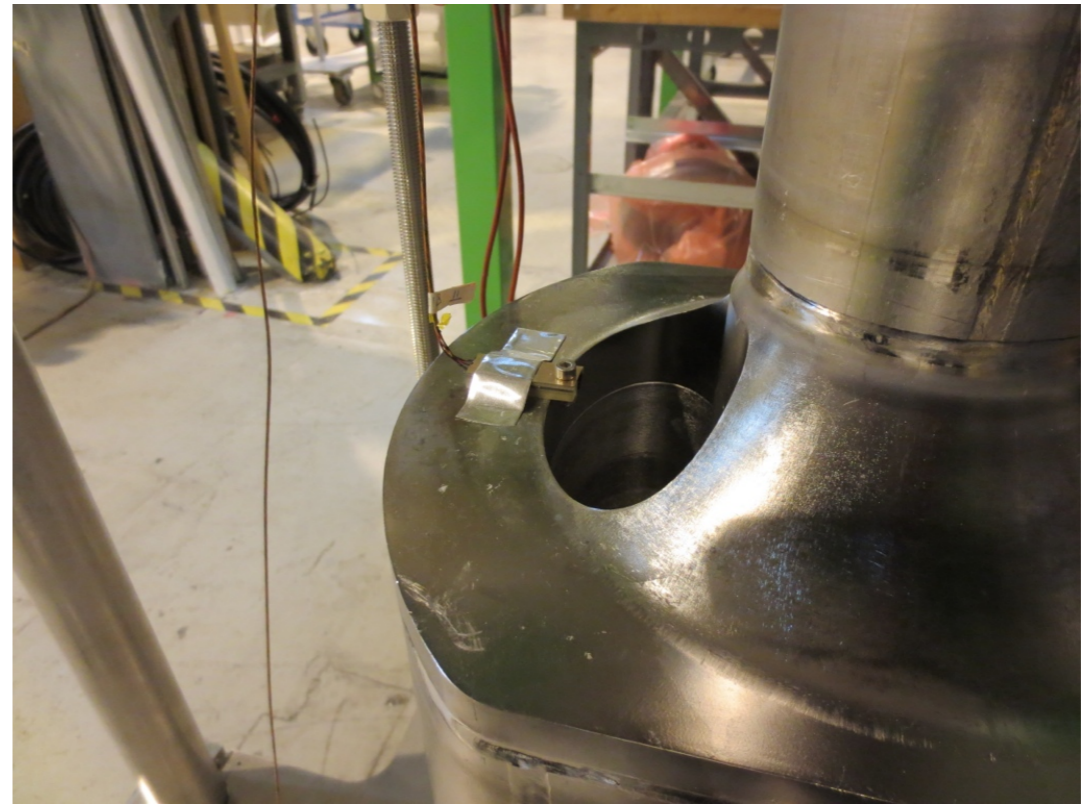

Leak tests:

