

The CMS L1 trigger: from LHC to SLHC

Andrew Rose
Imperial College, London

IOP HEP 2008, Lancaster
31.03.08-02.04.08

Summary

- CMS
- The data myth
- The Level-1 Trigger
- The Global Calorimeter Trigger
- LHC vs SLHC

CMS

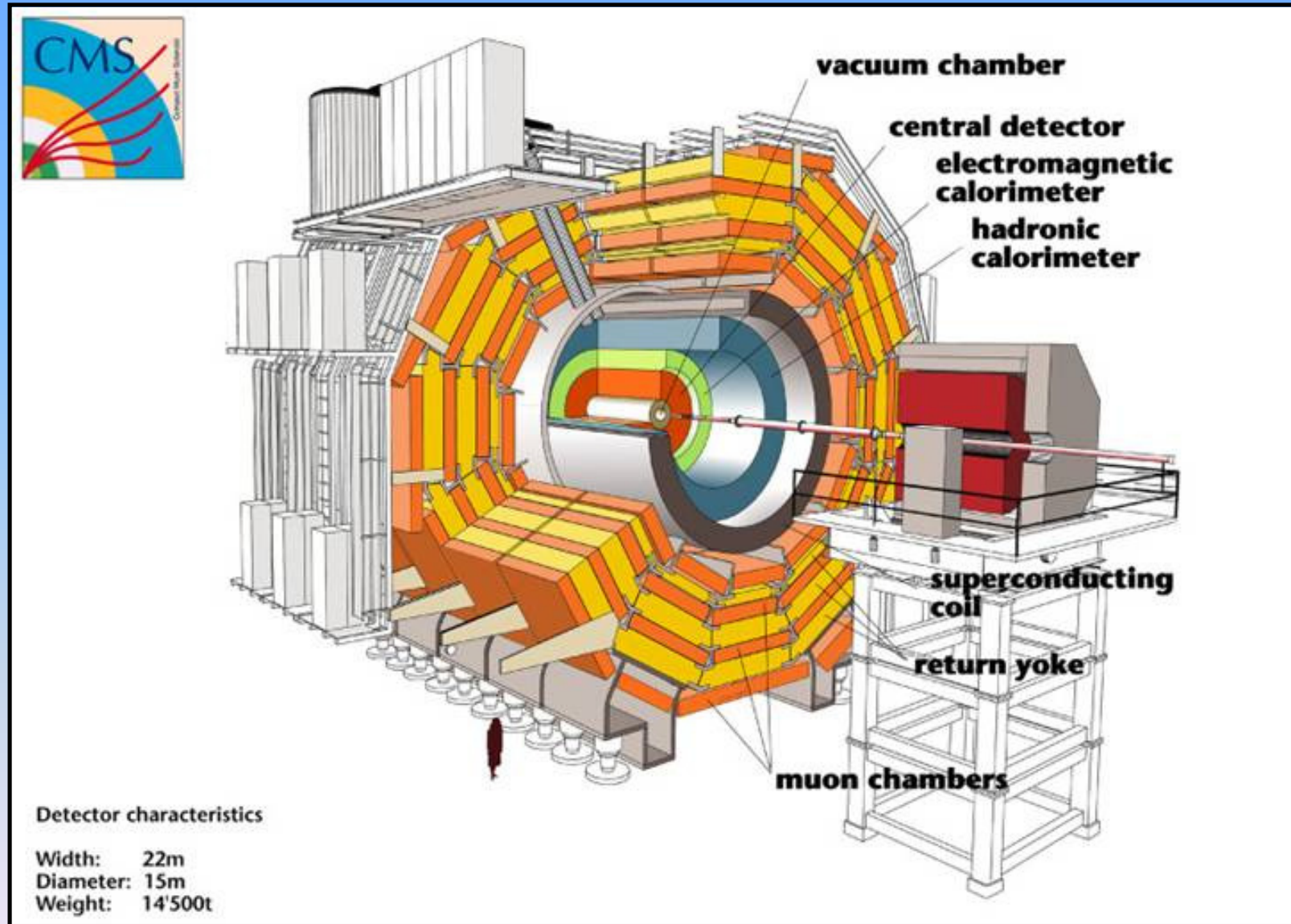

CMS

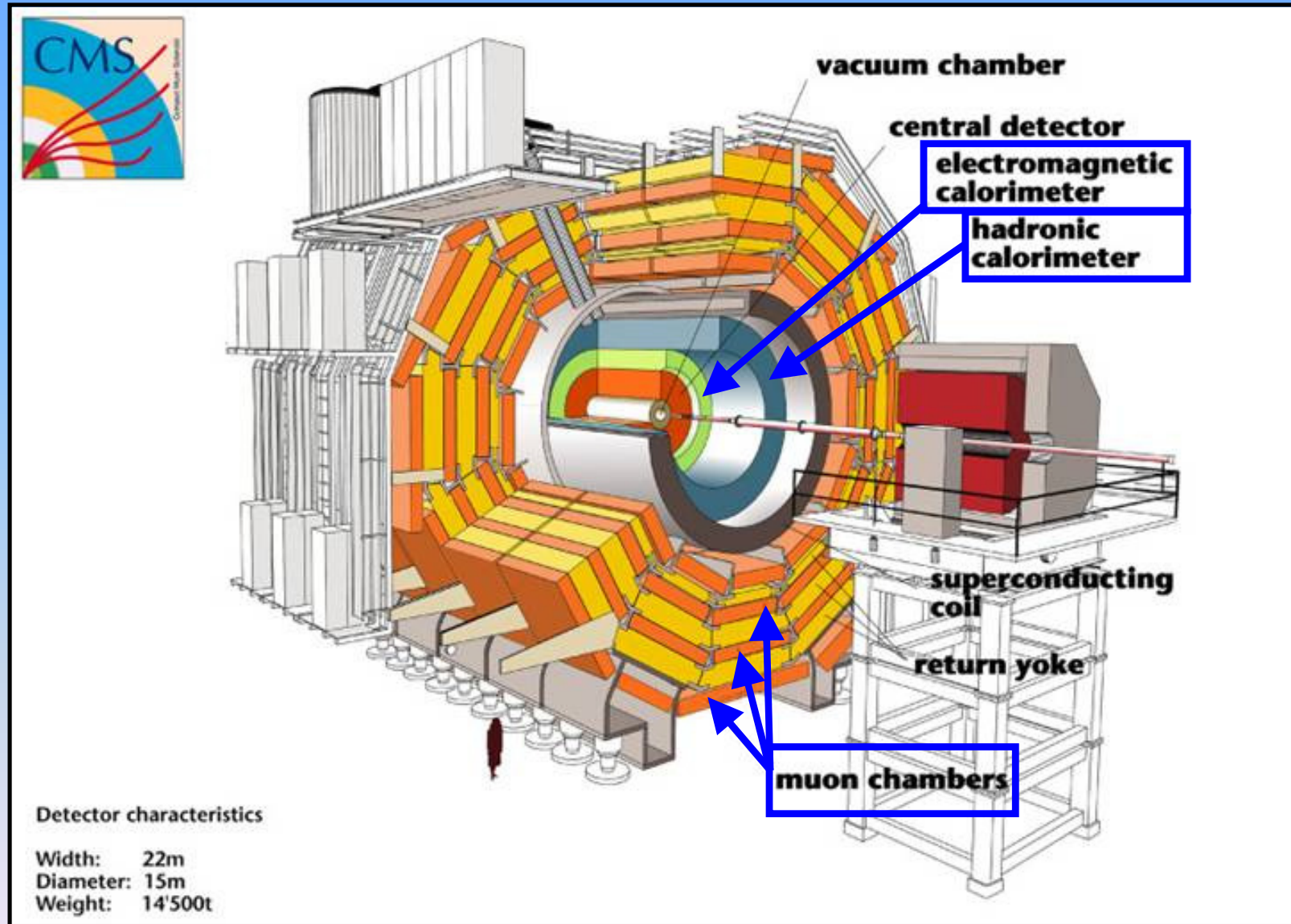

The data myth

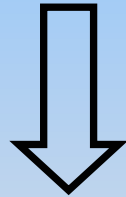
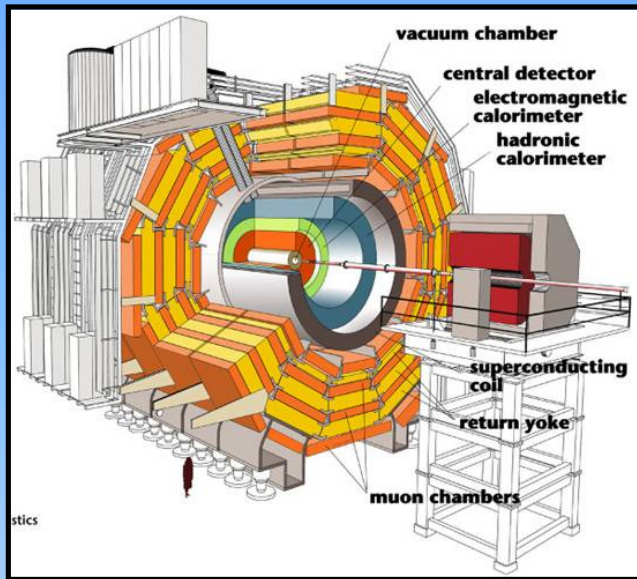

The Grid
The future
of all
science and
computing

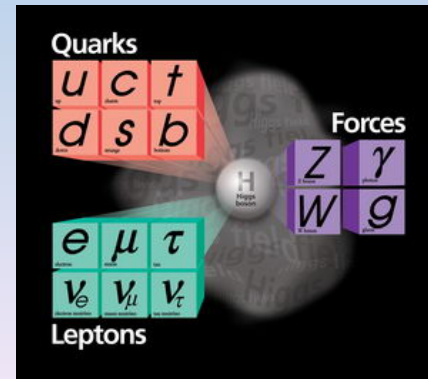
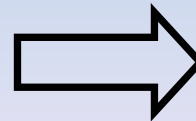

The Higgs
Boson
CMS will find in
first week of
running

The data myth

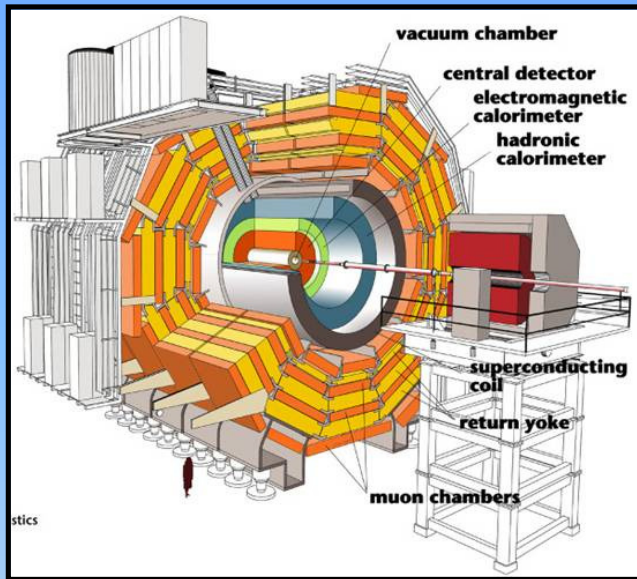

Something hazy happens here

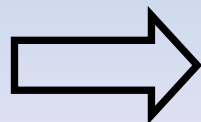

Higher Level Trigger (HLT)

- Event Reconstruction!
- Real Physics!

The data myth

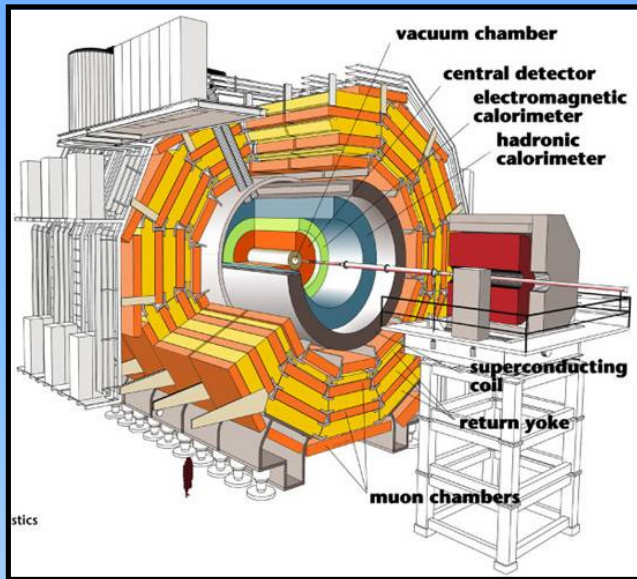

The Level-1
Trigger (L1T)



Higher Level
Trigger (HLT)

- Event Reconstruction!
- Real Physics!

The Level-1 Trigger

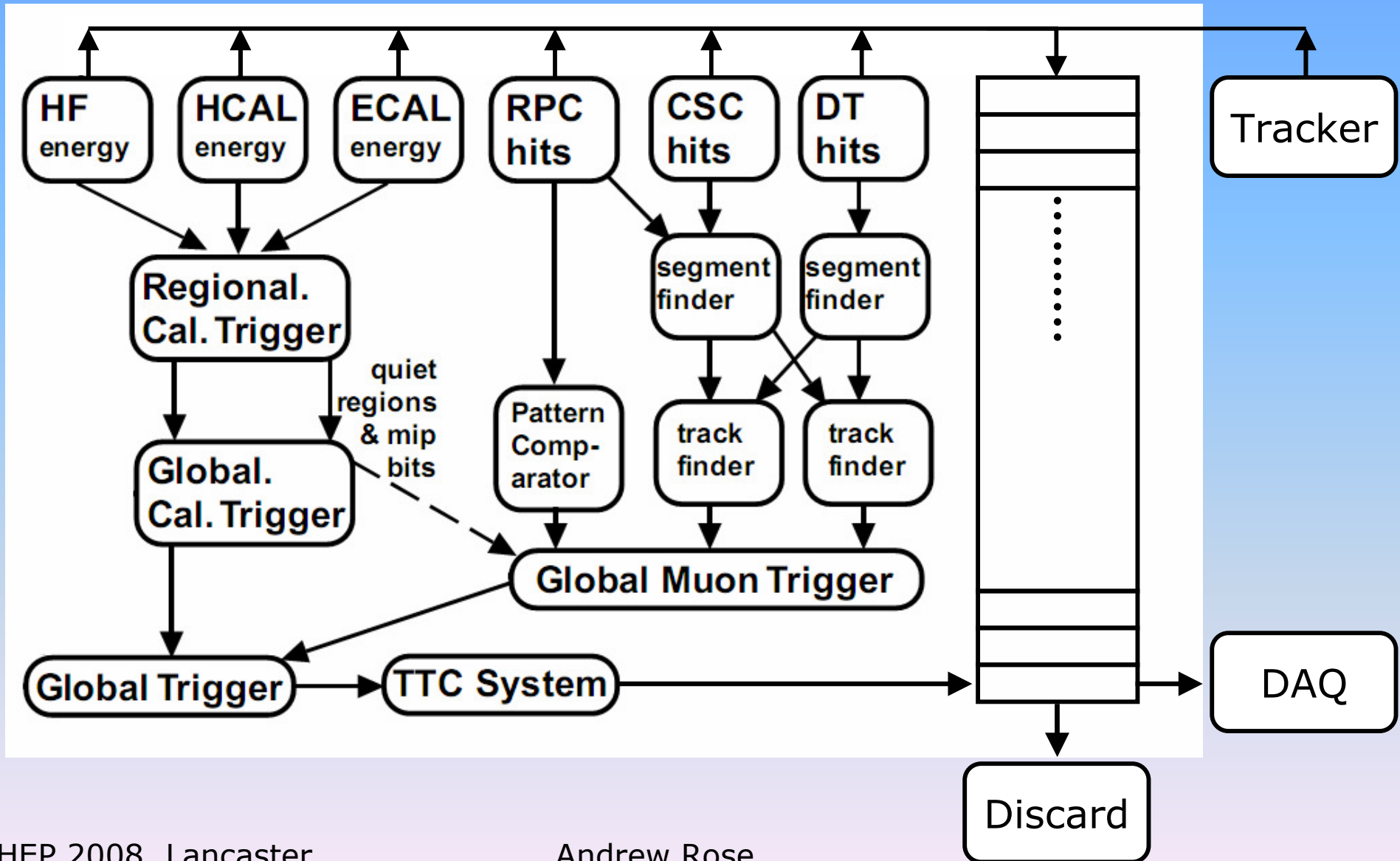

The Level-1 Trigger

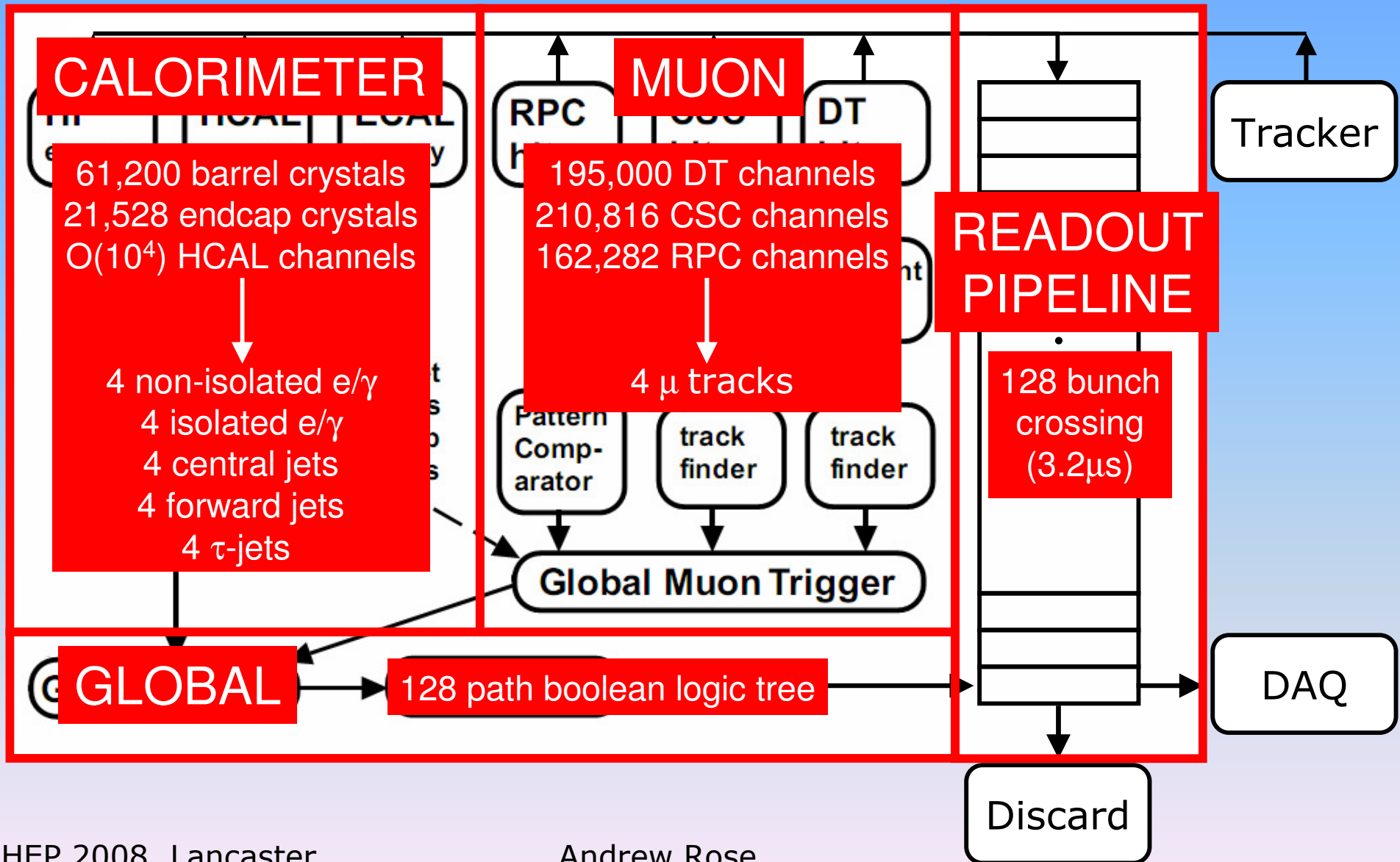

Global Calorimeter Trigger

The main problem for the GCT was physical space: The need to bring 108 32-bit wide parallel cables to a single point for processing

Achieved in stages

- Adapter cables that allowed the use of newer, smaller connectors
- Adapter cards (Source Card) which converting parallel copper links to Gbit/s optical links
- Optical patch panel to convert from single channel to 12-channel optical fibres
- 12-channel optical receivers wired directly to FPGAs with on-board Gbit/s deserialiser

Global Calorimeter Trigger

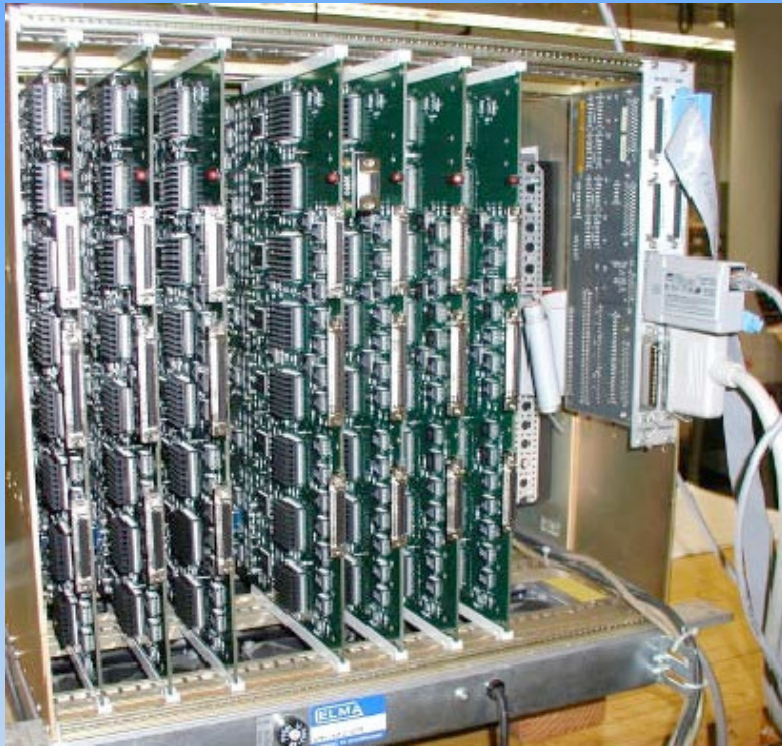

CMS RCT crates x3

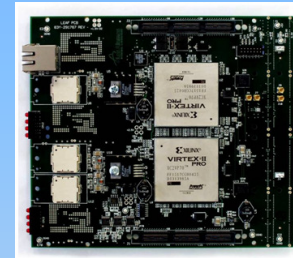

CMS GCT leaf card x1
(to scale)

Global Calorimeter Trigger

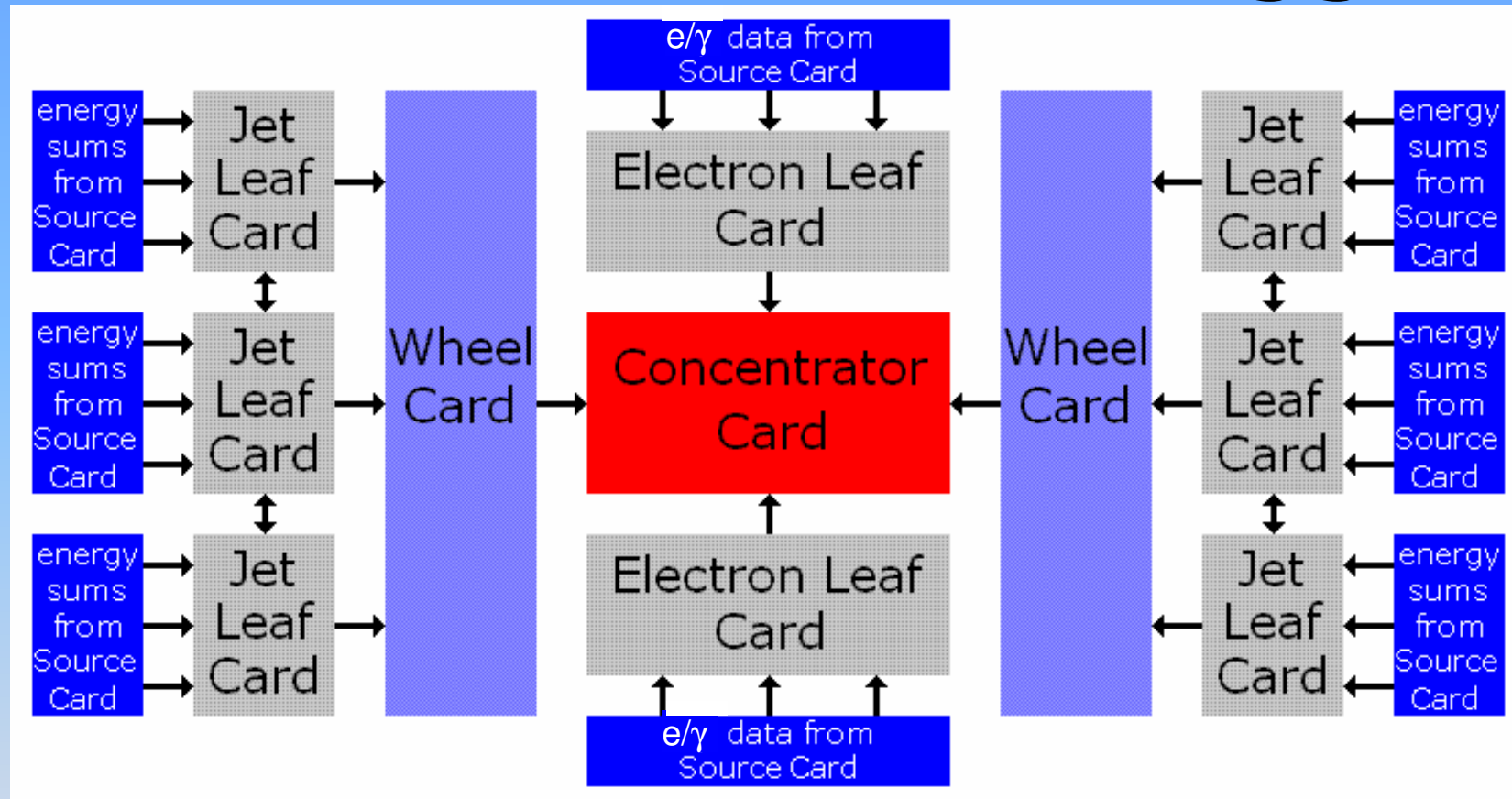

- 1) Each Jet Leaf Card forwards four highest energy jet candidates to its Wheel Card
- 2) The Wheel Card sorts candidates and forwards top four to the Concentrator Card
- 3) The Concentrator Card sorts the candidates from both Wheel Cards and from the e/γ Leaf Cards and forwards the top four of each type to the global trigger

Global Calorimeter Trigger

Lessons learned from the GCT:

- Large FPGAs offer far more flexibility than processing ASICs
- Large parallel copper buses no longer have any advantage over low-latency, high-speed serial links and are rapidly facing extinction...
- The arcane VME control bus is a severe hindrance, forcing those who want any kind of useful functionality to
 - a) customise it as is done elsewhere in L1T (yuk!)
 - b) supplement it with modern architectures (ethernet, usb, etc) as we have had to do
- The multitude of cable standards meant a lot of wasted time and effort
- The lack of a standardised data back-plane architecture for the L1T has caused no end of grief...

The response: The matrix processor...

Global Calorimeter Trigger

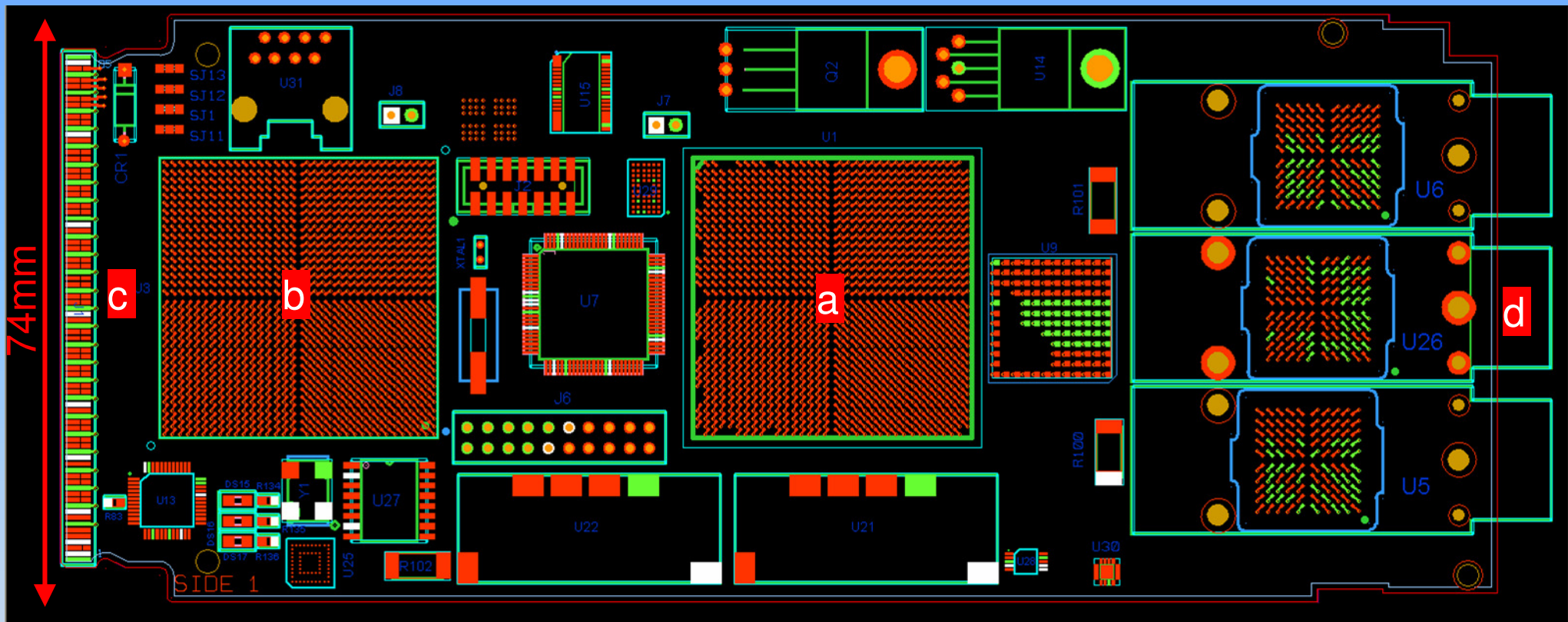

- μ TCA backplane
- Ethernet control bus
- A general purpose data processor @ 50Gbit/s
- Xilinx Virtex-5 FPGA (a)
- 72 x 72 non-blocking crosspoint switch (b)
- 20 x 2 3.2Gbit/s backplane connections (c)
- 16 x 2 3.2Gbit/s optical connections (d)

Global Calorimeter Trigger

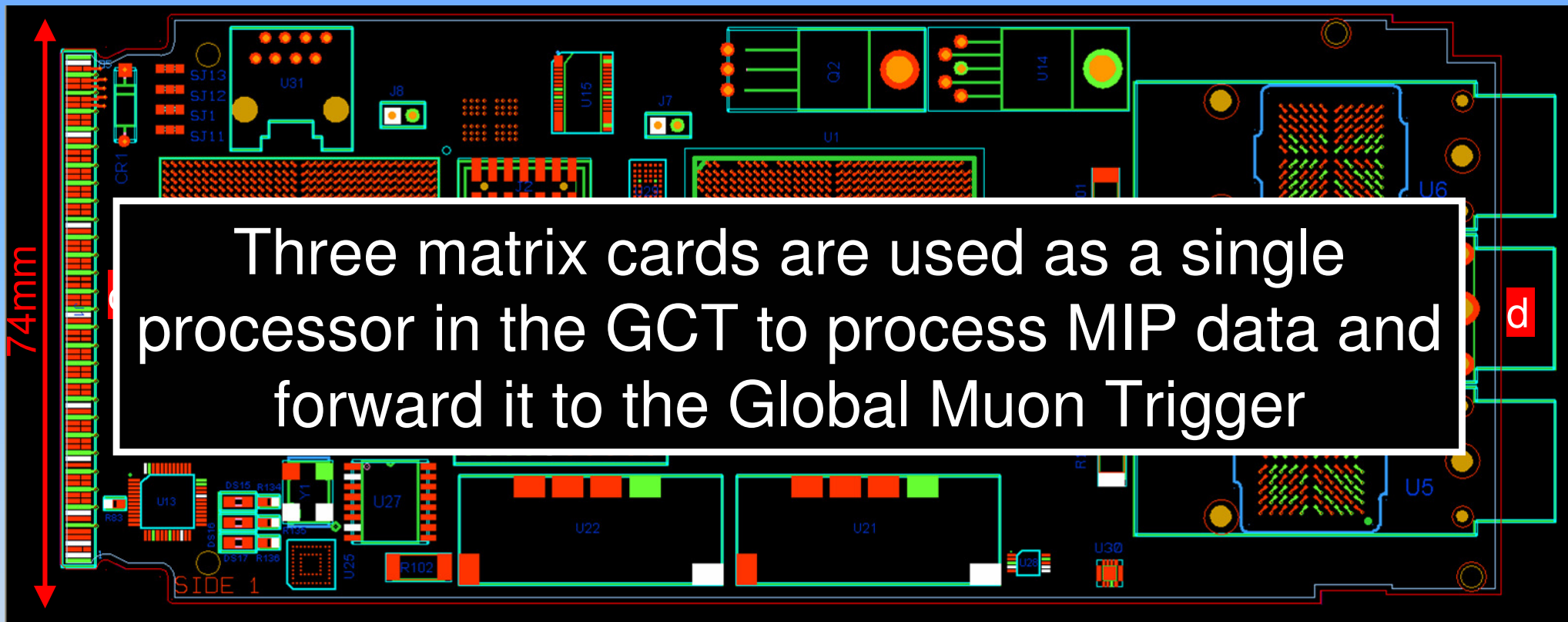

- μ TCA backplane
- Ethernet control bus
- A general purpose data processor @ 50Gbit/s

- Xilinx Virtex-5 FPGA (a)
- 72 x 72 non-blocking crosspoint switch (b)
- 20 x 2 3.2Gbit/s backplane connections (c)
- 16 x 2 3.2Gbit/s optical connections (d)

So what's to come...

LHC

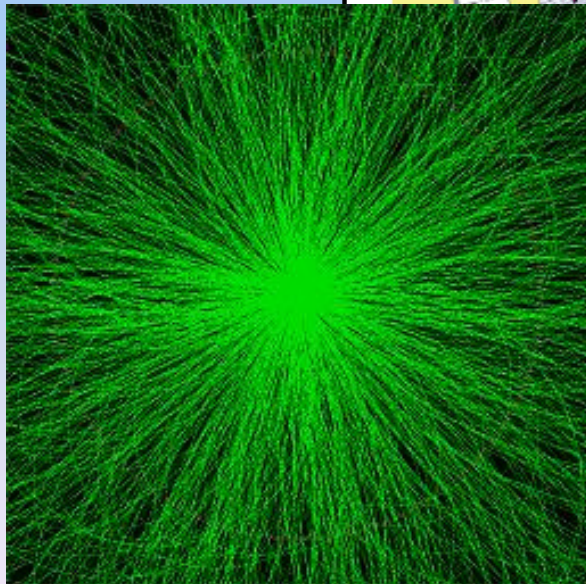
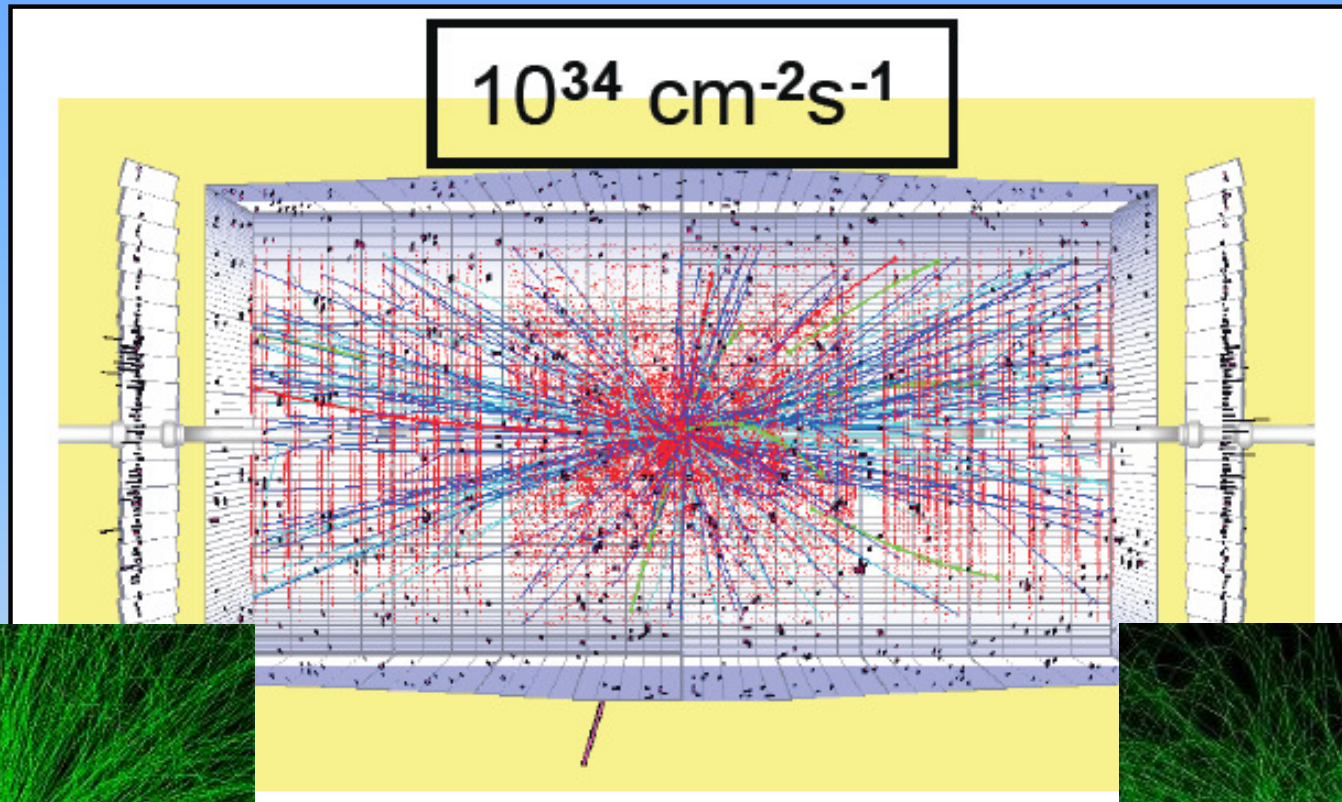

IOP HEP 2008, Lancaster
31.03.08-02.04.08

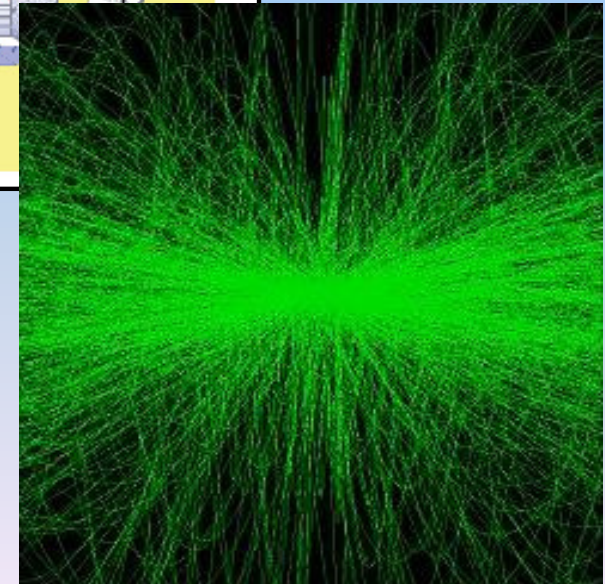

Andrew Rose
Imperial College, London

SLHC (circa 2015)

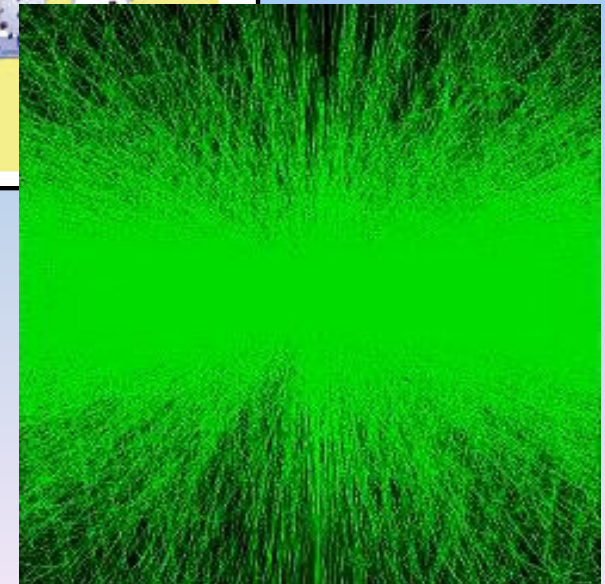
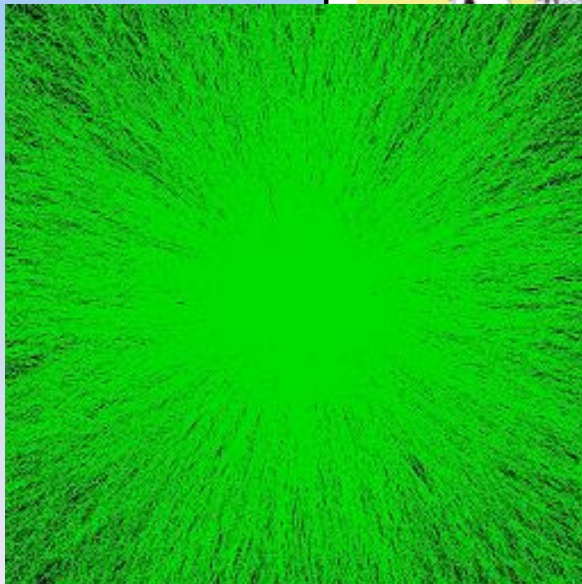
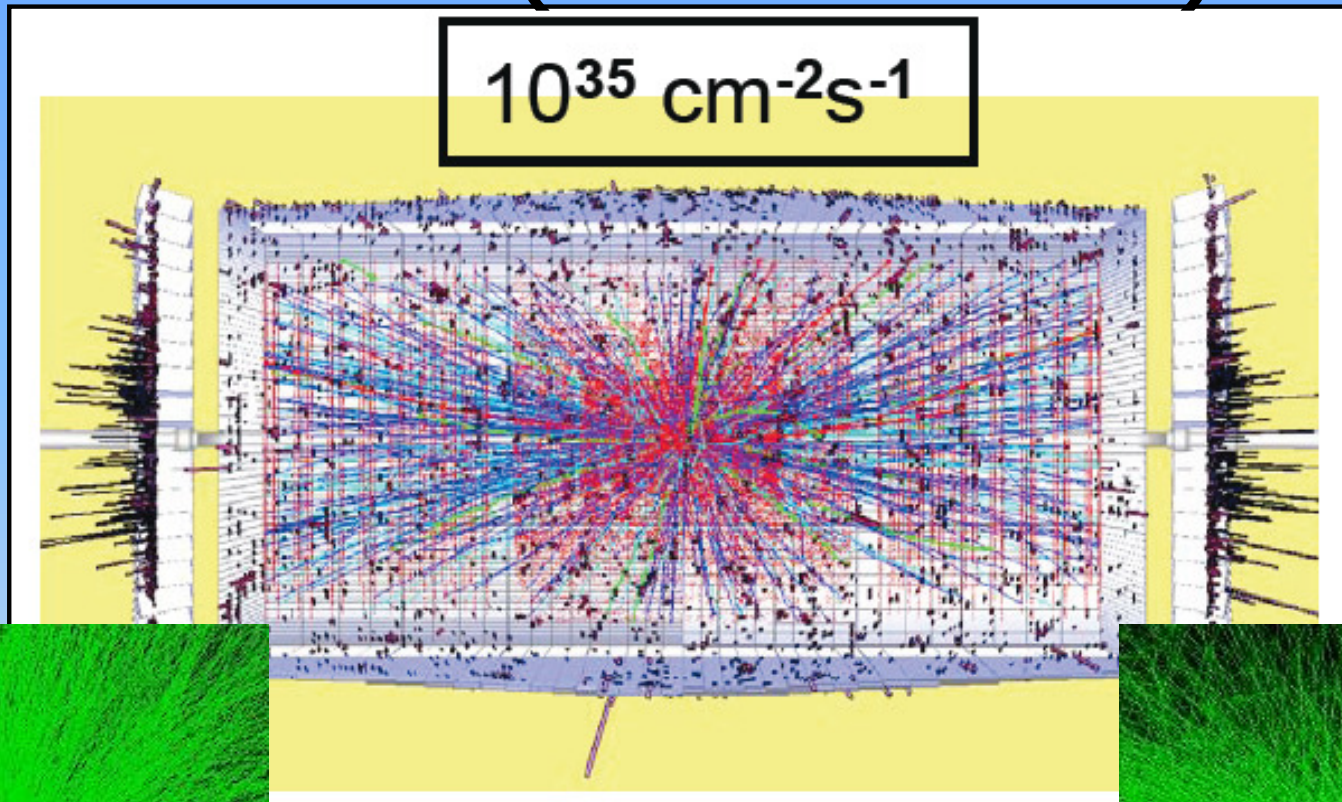

SLHC (circa 2015)

$$10^{35} \text{ cm}^{-2}\text{s}^{-1}$$

With increased luminosity the calorimeters lose the ability to separate jets/e/ γ from QCD background!

Need tracking information
(see M. Pesaresi, next...)

How to proceed: the philosophy

- Like current trigger:
 - Layer by layer approach
 - Combine at the very end
- Physics-like approach:
 - Particles ‘flow’ radially, can trigger behave similarly?
 - Use fine granularity data to create precision objects (or even ‘events’)
 - The downside: Raw trigger data from a minimal detector upgrade would top 15Tbit/s.

How to proceed: the hardware

- Like current trigger:
 - A vast collection of assorted electrical, mechanical and optical standards with absolutely no flexibility
- GCT (esp. matrix processor) approach:
 - Flexibility! Flexibility! Flexibility! FPGAs and optical patch panels
 - Standardization (with industry) of back planes, control buses and links
 - Design process moves from hardware to firmware. Cheaper, faster and more easily maintained

Conclusion

The CMS Global Calorimeter Trigger is in the final stages of commissioning ready for LHC start-up

In the process of constructing the GCT, a general purpose processing card capable of handling 50Gbit/s has been designed and built with the emphasis on flexibility and design quality

Studies are ongoing as to whether this, or similar, hardware could be used to handle fine granularity data for triggering at the SLHC

Extra slides

The Level-1 Trigger

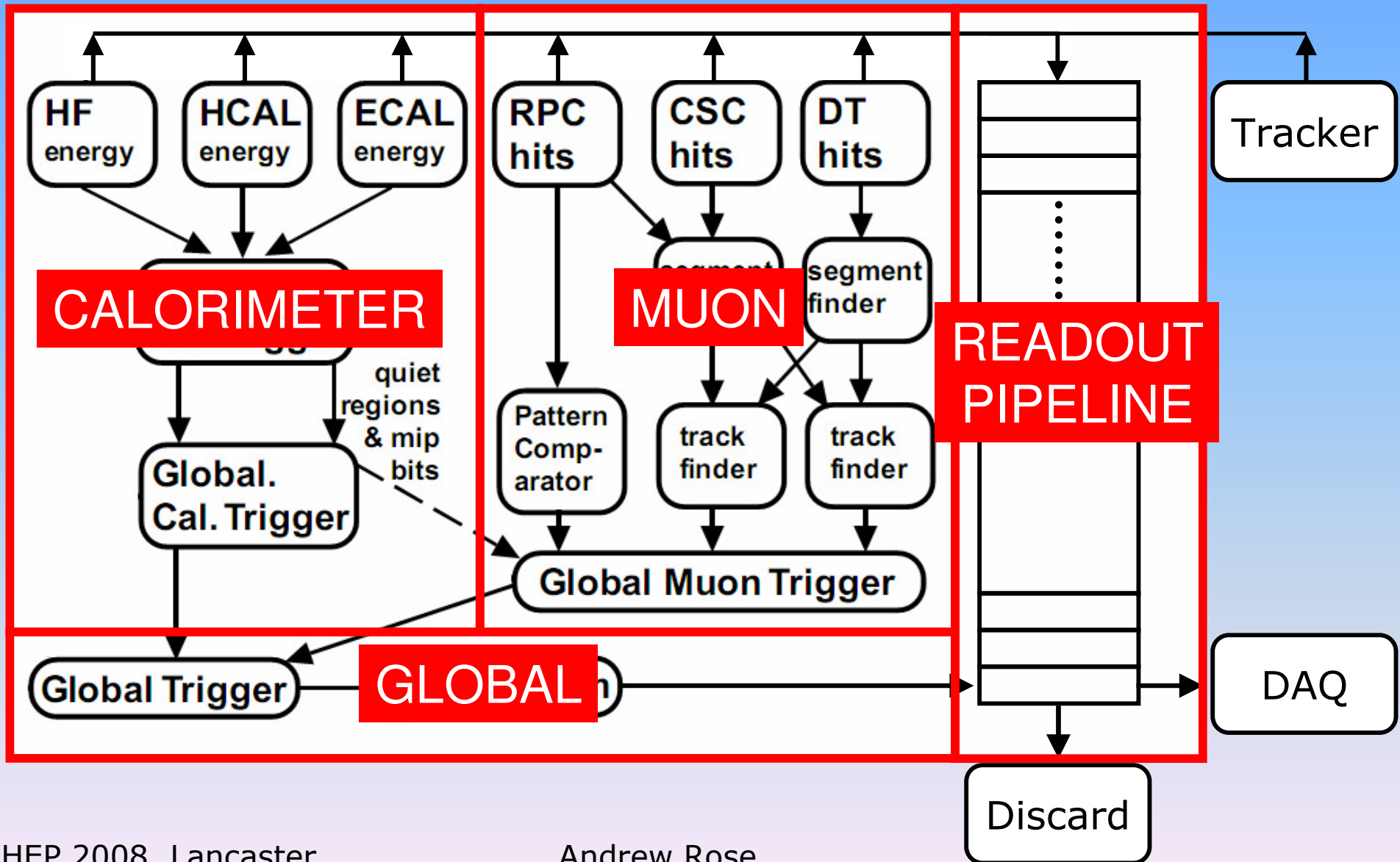

How is this done?

- By summing (eg crystals into towers, towers into regions, regions into super-regions = 'candidates', etc)
- By ranking and accepting only highly ranked objects
- Parallelised comparison of data against stored patterns

- All ASIC/FPGA based custom hardware
- No iterative algorithms (too slow)
- No tracker information (too slow)

Global Calorimeter Trigger

- For political reasons, the last part of the trigger chain to be built
- As such, could take advantage of new technologies
- Built around large FPGAs (Xilinx Virtex-2, -4 & -5)
- Follow the lead of the communications industry
- Uses high speed serial links rather than large parallel buses

Global Calorimeter Trigger

Six leaf cards, mounted on two wheel cards search for jets, defined as a region (4x4 trigger towers) having energy greater than all 8 surrounding regions.

These jets are classified as

- Central ($|\eta| < 1.5$)
- Forward ($|\eta| > 1.5$)
- Tau (if all 9 regions pass a tau veto)

The candidates are sorted by energy on each wheel card and the highest ranked candidates passed to the concentrator card where they are globally sorted. The highest 4 ranked candidates of each type are sent to the global trigger.

Two further leaf cards, mounted on the concentrator card sort the e/γ candidates and these are again forwarded to the concentrator and the highest ranked candidates sent to the global trigger.