



## Session 1: experiments: summary

Many thanks to D. Contardo, F. Gianotti, B. di Girolamo, R. Jacobsson, M. Lamont

**Selection of highlights and topics of discussion from the ECFA HL-LHC Experiments Workshop (1-3 Oct) which seemed (to the speaker) to be relevant to RLIUP Austin.**

*for proceedings, see: <https://indico.cern.ch/conferenceOtherViews.py?view=standard&confId=252045>*

The “physics landscape” 30fb-1  $\rightarrow$  300fb-1  $\rightarrow$  3000fb-1 and thus the physics potential of the HL-LHC. **Fabiola.**

**The need to upgrade certain key detector elements of ATLAS and CMS for ANY programme beyond 300fb-1. Beniamino**

The role of the upgrade changes to expts in mitigating the high rate, high pile-up conditions of HL-LHC needed to reach the 3000fb-1 target in a reasonable timescale.

Prospects for pile-up mitigation by tuning the luminous region. **Didier.**

**Physics motivation & realisation of the LHCb upgrade, plus the forward physics and ALICE p-p programmes. Richard**

....Which left **Mike** as the victim trying to fit the disparate requirements for operation and upgrade into a workable schedule, taking into account some constraints from accelerator consolidation and upgrade options.



## EFCA HL-LHC expts workshop: 1-3 Oct

Motivation: ESPP document adopted by Council in May

c) The discovery of the Higgs boson is the start of a major programme of work to measure this particle's properties with the highest possible precision for testing the validity of the Standard Model and to search for further new physics at the energy frontier. The LHC is in a unique position to pursue this programme. *Europe's top priority should be the exploitation of the full potential of the LHC, including the high-luminosity upgrade of the machine and detectors with a view to collecting ten times more data than in the initial design, by around 2030. This upgrade programme will also provide further exciting opportunities for the study of flavour physics and the quark-gluon plasma.*

Strategy explicitly recommends 3 ab<sup>-1</sup> target

**DG → we should consider this tacit approval for the HL-LHC programme and proceed.**

Further evaluation of:      physics reach  
   technical feasibility for expts and machine  
   timeline & cost estimates

needed for formal approval by Research Board, Council, Funding Agencies etc etc

*“Do not wait to strike until the iron is hot....make it hot by striking!!!”      W.B. Yeats*



# Physics landscape & further exploration

*Think like a wise (wo)man but communicate in the language of the people*

*W.B. Yeats*

Three main results from LHC Run-1

We have consolidated the Standard Model  
(wealth of measurements at 7-8 TeV, including the rare, and very sensitive  
to New Physics,  $B_s \rightarrow \mu\mu$  decay)  
—> it works BEAUTIFULLY ...

We have completed the Standard Model: Higgs boson discovery  
(almost 100 years of theoretical and experimental efforts !)

We have NO evidence of new physics

Note: the last point implies that, if New Physics exists at the TeV scale and is discovered at  $\sqrt{s} \sim 14$  TeV in 2015++, its spectrum is quite heavy —> it will require a lot of luminosity (—> HL-LHC  $3000 \text{ fb}^{-1}$ ) & energy to study it in detail —> implications for future machines (e.g. most likely not accessible at a 0.5 TeV LC)



## Physics landscape & further exploration

However: we also know that the SM is not the ultimate theory of particle physics, because of the many outstanding questions, including:

- Why is the Higgs boson so light (“naturalness” problem) ?
- What is the the nature of the dark part (96% !) of the universe ?
- What is the origin of the matter-antimatter asymmetry ?
- Why is gravity so weak ?

There are compelling reasons to believe that answers to some of the above questions lie at the TeV scale, whose exploration JUST started ...

—> The **STRONG** physics case for the HL-LHC with  $3000 \text{ fb}^{-1}$  comes from the imperative necessity of exploring this scale as much as we can with the highest-E facility we have today (note: no other planned machine, except a 100 TeV pp collider, has a similar direct discovery potential). Likely, and perhaps more importantly, the HL-LHC will also tell us what are the right questions to ask and how to continue.



# LHC $\rightarrow$ HL-LHC: *THE* Higgs factory

today : ATLAS+CMS have 1400 Higgs events  
 HL-LHC: (3000fb-1) > 3M/170M useful for precise measurement

- ❑ Measure as many Higgs couplings to fermions and bosons as precisely as possible
- ❑ Measure Higgs self-couplings (give access to  $\lambda$ )
- ❑ Verify that the Higgs boson fixes the SM problems with W and Z scattering at high E

## Couplings

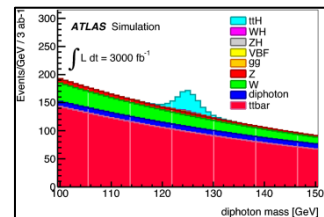
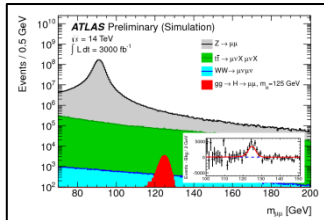
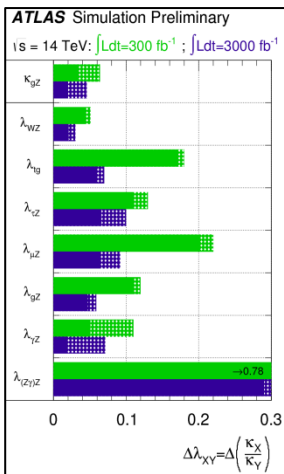

x 1.5 to 2 for 300  $\rightarrow$  3000fb-1 + Access to rare processes

## Self-coupling

$ttH \rightarrow \gamma\gamma$

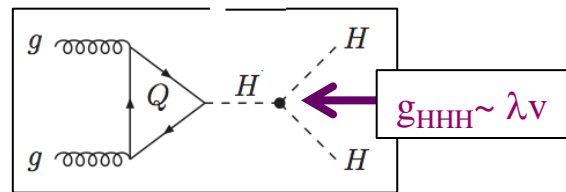

$H \rightarrow \mu\mu$

Difficult measurement  
 precision 30%(?) for 3000fb-1

## Vector boson fusion

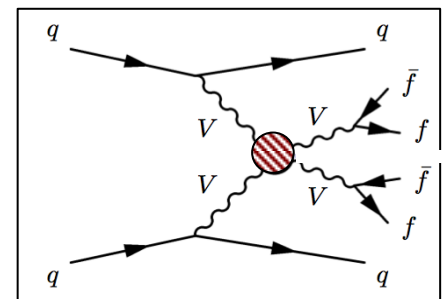

Check if Higgs does the (whole) job of cancelling divergences



# Experiment upgrades

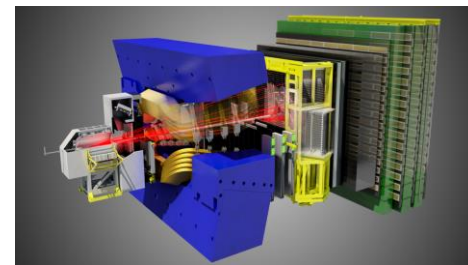
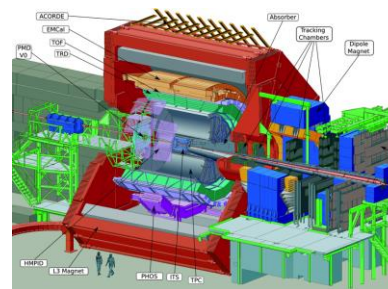
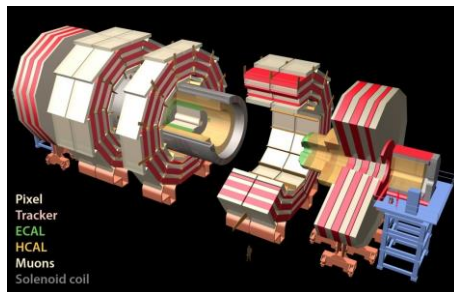
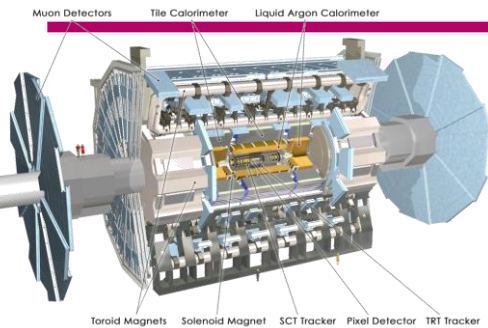

Study Standard Model in detail, including Higgs couplings and eventually self-coupling  
Continue search for Physics beyond the SM.

Requires x10 in statistics beyond design 300fb<sup>-1</sup>

Phase 0,1 upgrades in LS1, YETS and LS2 to match LHC performance over Run 2,3.

**Key components of present detectors will not survive radiation beyond 500fb<sup>-1</sup> → Phase2**

in LS3, equip for 3000fb<sup>-1</sup> p-p over 10 years  
LHC → HL LHC : <pileup> (23 → 140)

High statistics HI measurements using rare probe particles at low p<sub>T</sub>.

10nb<sup>-1</sup>, min bias

**Single phase major upgrade to detector & readout in LS2**

Record very high stats to search for effect of possible new physics on flavour structure. (complementary to ATLAS & CMS progr)  
50fb<sup>-1</sup>, 40Mz readout

**Single phase major upgrade to detector & readout in LS2**



# Phase1 upgrades

“PIC” = performance improving consolidation”

**ATLAS & CMS:** some analogy to PIC’s – few radical changes in technology

- Phase 1 upgrades are needed to maintain performance beyond  $1 \times 10^{34}$  Hz/cm<sup>2</sup>, PU ~ 25

By run 3: pixel, new muon stations, trigger, calorimeter improvements:

- With these upgrades ATLAS and CMS will be able to operate with good performance up to PU of ~ 70 and integrated luminosity ~ 500 fb<sup>-1</sup> (max) [ PU will be severe limit if @ 50ns]

**LHCb and ALICE:**

potential of existing detectors becoming exhausted by LS2 (data doubling time v. long)  
 major upgrades to detector & readout in LS2 —> program extending well into HL-LHC era  
 operation assumes levelled luminosities for rate tolerance, efficiency and physics stability

## LHCb

Replacement of VELO  
 Major upgrade of RICH optics,  
 Major upgrade of tracking system (technology decisions by end of this year)  
 Upgrade all existing detector FE electronics  
 1 MHz —> 40MHz

## ALICE

All readout :  
 500Hz —> 50kHz with min bias trigger  
 new beampipe,  
 Inner tracking system  
 4-GEM endplates for TPC



# ATLAS & CMS "PICs": pixel trackers

4 layer pixel trackers

3 → 4 layer  
 low mass  
 1<sup>st</sup> layer lower r  
 (new beampipes)  
 ↓  
 Pileup mitigation



ATLAS

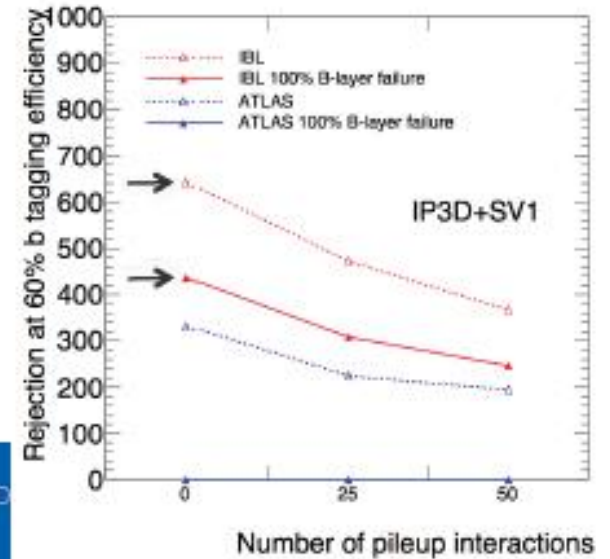
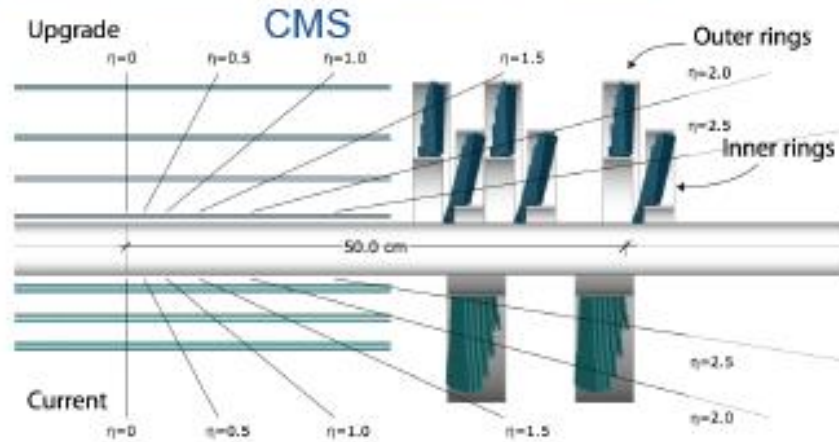
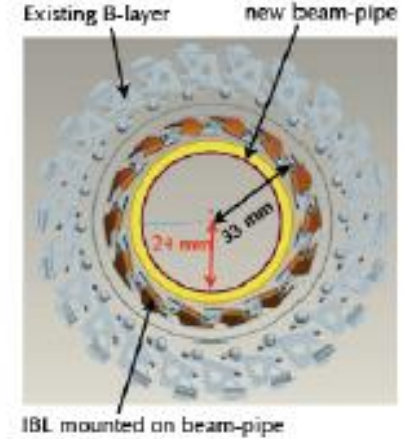





# ATLAS & CMS "PIC's": muon systems

additional or upgraded detector layers

Maintain control of  $\mu$  trigger rate at low  $p_T$  for high lumi

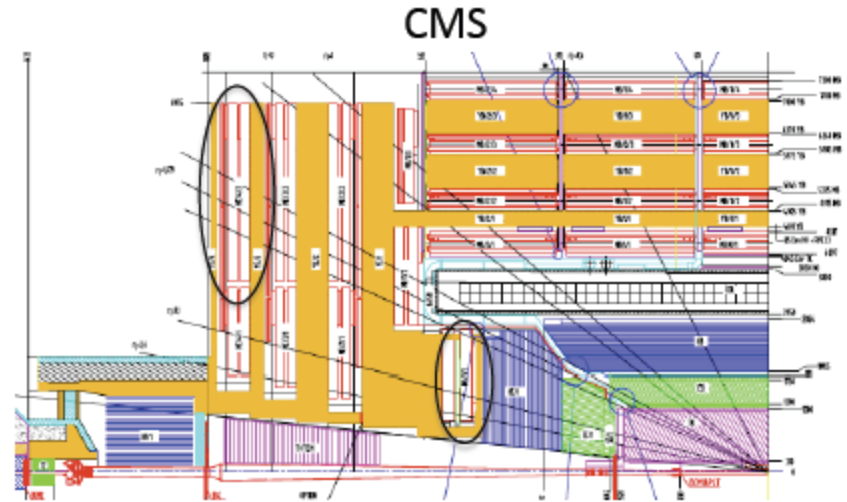
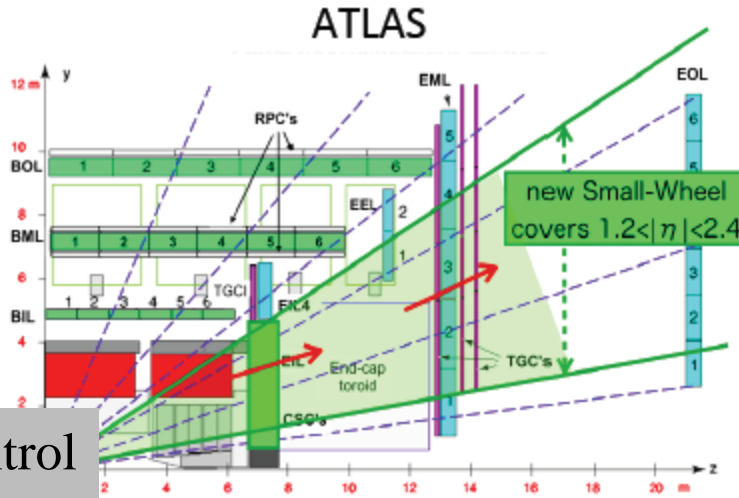

Similar issues and benefit in trigger for upgrades in ATLAS and CMS

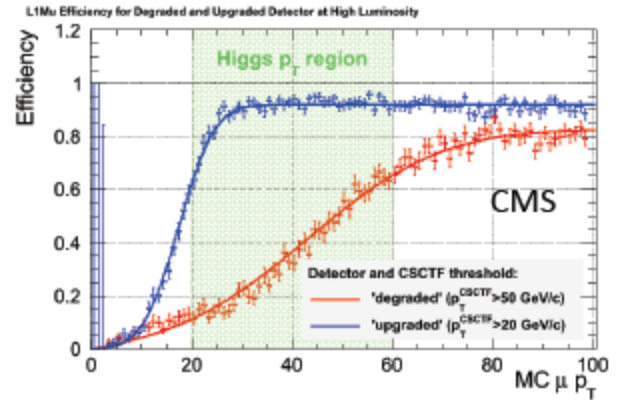
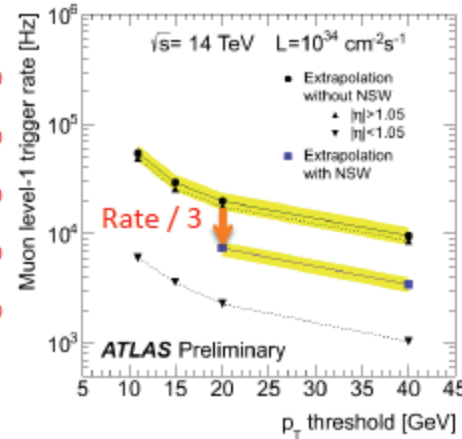
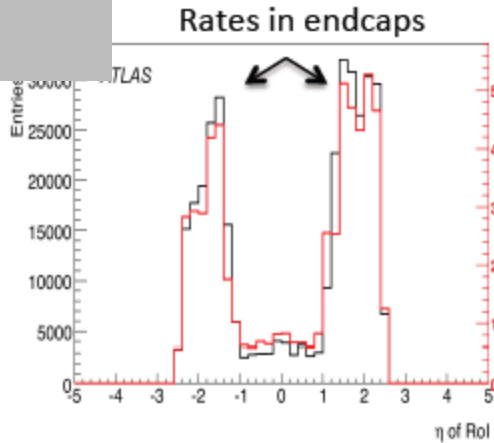



# ATLAS & CMS: Phase 2 upgrades mandatory

**Silicon trackers:** sensor leakage currents increase with radiation dose =  $\int L dt$ .

- very well modelled
- can predict that existing detectors **will be seriously compromised at  $\sim 500\text{fb}^{-1}$**
- key physics quantities degrade much faster than layer inefficiency

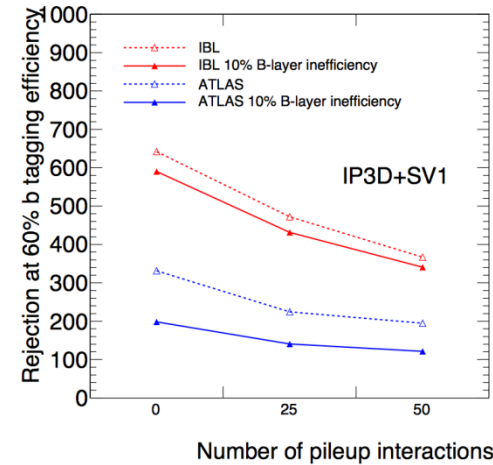
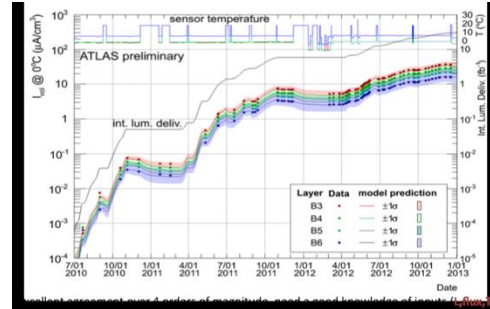

**Calorimeters:**

Signal (light) output reduced by radiation damage  
 Can prolong life with smarter readout but **at  $\sim 500\text{fb}^{-1}$ , there's nothing left to work with.**

**Extrapolated Signal Degradation of CMS Hadron Endcap**

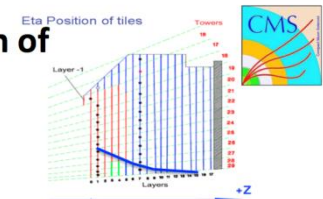
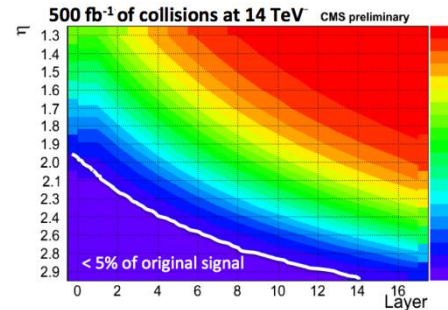

- Extrapolated degradation based on exponential parameterizations of observed damage as a function of sampling depth (layer) and  $\eta$
- At  $500\text{fb}^{-1}$ , in the high  $\eta$  region, signal drops to 5% or less of the original value.

- ✓ CMS will upgrade Front End Electronics of HE (and HB) in LS2. This upgrade will ensure performance of HE up to LS3:
- ✓ Photon Detection Efficiency (PDE) of SiPMs will be x3 higher than in present photodetectors.
- ✓ Depth segmentation will allow for re-weighting of radiation damage degradation.

**CMS HCAL Endcap calorimeter will be replaced during LS3**

**Trigger systems:** maintain selectivity at high rate and pile-up, by adding info (tracking) increasing decision time & output bandwidth



# ATLAS & CMS Phase 2 trackers

Didier

Light-weight designs using 2-phase CO2 cooling systems

Pixels will need replacement in LS's

## Common features

### Granularity

- Strip pitch  $\sim 80\text{-}90\ \mu\text{m}$  & length  $\sim 2.5/5\ \text{cm}$  in inner/outer layers (& macro-pixel sensors in CMS 1.5 mm long)
- Pixel pitch  $\sim 25\text{-}30\ \mu\text{m}$  and  $\sim 100\ \mu\text{m}$  length

### Sensor Technology

- n-in-p planar technology for increased radiation hardness
- n-in-n, 3D, diamond or other technologies for innermost layers

### Trigger implementation

- Custom ASIC Associative Memory chips (as developed for FTK) for pattern recognition followed by a track fit in FPGA

## Specific configurations

- CMS trigger read-out at 40 MHz - Pt-module concept select "stubs" for tracks with  $P_t \geq 2\ \text{GeV}$
- ATLAS read-out region of interest at  $\geq 500\ \text{kHz}$

## Proposal to extend coverage of Pixel

detectors up to  $|\eta| \sim 4$

- Associate jets to primary vertex through track matching

ATLAS design

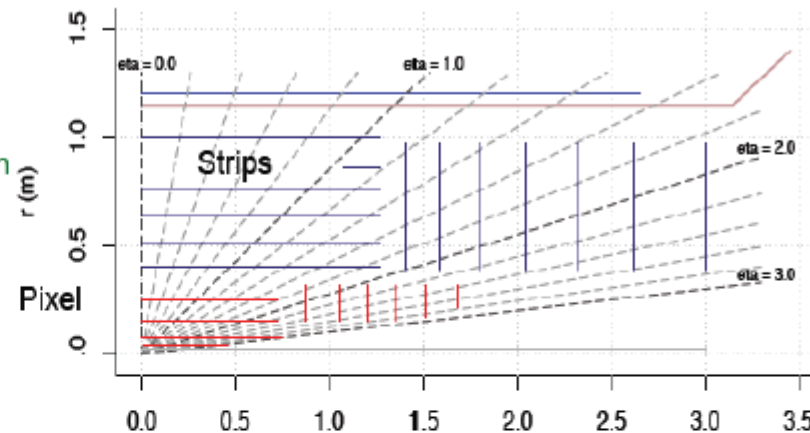

CMS design

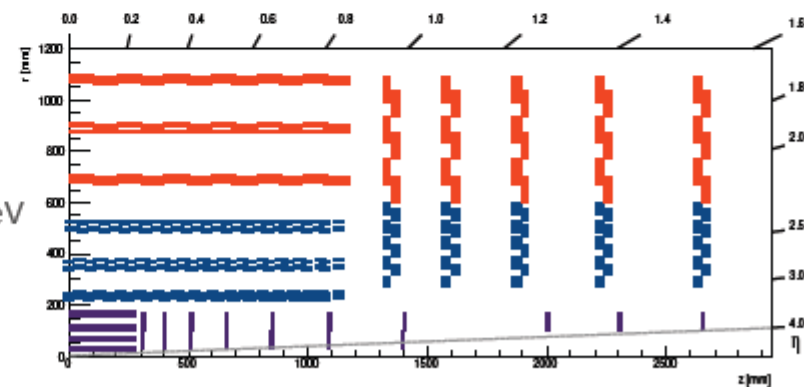



# Phase2: Calorimeters

## Summary table

Experi-ment	detector	technology	Critical condition	maximal value for Phase2 of LHC	Expected degradation, considered mitigation
ALICE	PHOS	PbWO4	Hadron fluence	$< 10^9$ h/cm <sup>2</sup>	OK
ALICE	EMCal/Dcal	Pb/Scint Shashlik	Radiation Dose	~ 0.1 kRad	OK
LHCb	ECAL	Pb/Scint Shashlik	Radiation Dose	~ 6 Mrad	will replace central cells during LS3 (spares exist)
LHCb	HCAL	TileCal	Radiation Dose	~ 1 Mrad	Not critical, accept the loss
ATLAS	ECAL Barrel	LAr	Inst. luminosity	OK up to $10^{35}$ cm <sup>-2</sup> /s	OK
ATLAS	ECAL Endcap	LAr	Inst. luminosity	OK up to $5 \cdot 10^{34}$ cm <sup>-2</sup> /s	OK, re-calibrate if required
ATLAS	HCAL Endcap	LAr	Inst. luminosity	OK up to $8 \cdot 10^{34}$ cm <sup>-2</sup> /s	OK
ATLAS	HCAL Barrel	TileCal	Radiation Dose	~ 0.3 Mrad	Re-calibrate
ATLAS	Forward	LAr	Inst. luminosity	Possible degradation above $2 \cdot 10^{34}$ cm <sup>-2</sup> /s	May have to replace or add new detector during LS3
CMS	ECAL Barrel	PbWO4	Hadron fluence	$2 \cdot 10^{12}$ h/cm <sup>2</sup>	Re-calibrate
CMS	HCAL Barrel	Brass/Scint	Radiation Dose	~ 0.1 Mrad	Re-calibrate
CMS	ECAL Endcap	PbWO4	Hadron fluence	~ $2 \cdot 10^{14}$ h/cm <sup>2</sup>	Will be replaced during LS3
CMS	HCAL Endcap	Brass/Scint	Radiation Dose	~ 10 Mrad	Will be replaced during LS3
CMS	Forward	Steel/Quartz fibers	Radiation Dose	~ 500 Mrad	Re-calibrate



# Trigger systems

Didier

**Phase 1:** L1 trigger upgrades to operate at 50 PU within the limitation of 100kHz output rate:  
 ongoing from LS1 through LS2. exploit: additional muon layers  
 better calorimeter granularity  
 more complex event info/analysis

**Phase 2:**  
 Increase bandwidth  
 latency  
 HLT o/p rate  
 use tracker in trigger

Major changes to detector electronics required.

- ATLAS
  - Increase Level 1 bandwidth to 500 kHz in 5  $\mu$ s latency
    - Readout of tracker information in Region of Interest
  - Level 2 in 20  $\mu$ s latency with tracks and 200 kHz HLT input
  - Possible HLT output up to 10 kHz
  - Requires
    - Upgrade of front-end and back-end electronics of Calorimeter and Muon detectors
  
- CMS
  - Readout Tracker “stubs” at 40 MHz
  - Readout crystal granularity in ECAL
  - Increase latency to 10  $\mu$ s and level 1 rate up to 1 MHz
  - Possible HLT output up to 10 kHz (present HLT rejection)
  - Requires
    - New ECAL Barrel front-end electronics
    - Upgrade of back-end electronics
    - Increased computing power - HLT can benefit from L1-track reconstruction (as for ATLAS phase 1 FTK)

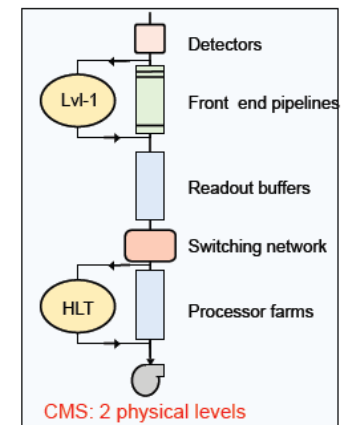
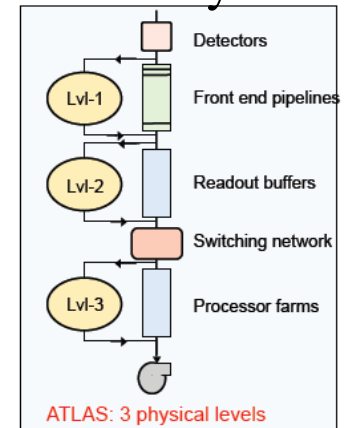



# Pileup and luminous region

## Pile-up effects visible throughout detector & readout chain

- Occupancy – difficulty separating event information
- Memory buffers on front-end chips
- Selectivity of trigger system working with limited info
- Links between the front-end and the back-end electronics
- Limitations in processing power in back-end electronics
- Links between the back-end & rest of DAQ
- Event reconstruction in high level trigger & offline

## Both ATLAS and CMS are:

- **designing Run 4 detectors to cope with mean pile-up of 140 ( $\langle 140 \rangle$ ) ( $25\text{ns}$ ,  $5 \times 10^{34}$ )**  
“tails” up to 200 events per crossing. [Degradation not sudden, but tails have large effect]
- **very interested in methods (eg crab kissing) allowing tuning extent of luminous region in time and space**, to reduce the pileup density in either  $z$  or  $t$  dimensions, *although*:  
**Line density  $1.2 \text{ ev/mm} \rightarrow 0.6 \text{ ev/mm}$  does not open up a door to accepting 2x the inst lumi** (mean pile-up also has bad effects eg neutrals in calorimeters)
- The potential to exploit **fast timing ( $\sigma \sim 10\text{ps}$ ) to mitigate pile-up still requires substantial R & D** (but there is a dedicated community pursuing this).

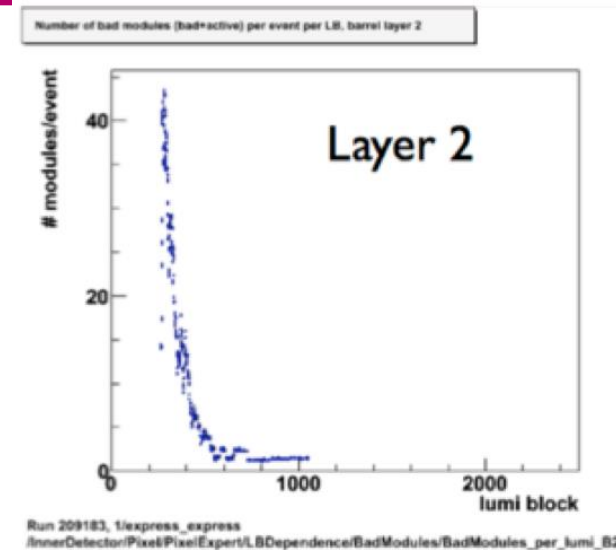



## Operation: special requests

Apart from usual programme of p-p and Pb-Pb at top energy

- p-p reference data: equiv energy: ALICE (6 pb-1: takes about 2 month @ 200kHz)  
end of run 3 : dominant ref data requirement  
ATLAS/CMS 300pb-1
- p-Pb proven to be very interesting : requested for Run 2 : 50nb-1 @ 5.1 or 8 TeV  
after LS2 : ~1pb-1
- new ion species: p-Ar and Ar-Ar possible requests
- Luminosity calibrations needed at every energy
- Forward programmes :  
TOTEM High  $\beta^*$  & AFP & CMS-TOTEM fwd programme at low  $\beta^*$  in Runs 2,3  
**no high  $\beta^*$  running anticipated after LS3**  
(ATLAS and CMS beampipes bore to be kept at ~45mm despite TAS at ~60mm)  
forward physics at nominal lumi may continue thereafter (eg LHCb)
- Experiment magnet field reversals as previously :  
LHCb will need to switch dipole polarity every ~2 weeks to control systematics  
ALICE will need to switch solenoid polarity occasionally



# Schedule: “The Matrix”

From AB talk :” reloaded” with LIU & LHC information

	Run 2	EYETS	LS2	Run 3	LS3
ALICE		Contingency	18 mo. Shift into 2018		
ATLAS	3 years	No	14 mo. Start 2018		27 (35) mo. Start 2022
CMS	EYETS plus N months	19 weeks	14 – 18 mo. (Pref ≥ summer 2018)		30 – 35 mo. Start 2023
LHCb		Contingency	18 mo. End 2018		
Cryo	4 years max.	Selective maintenance			
Maintenance		Selective maintenance	16 mo.		20 mo.
LIU		9.5 months for L4 connect/or cable prep.	20.5 mo. beam to pilot		
LHC	3 years max contiguous	Opens way for year 4	18 mo.	3 years	2 years





## EYETS (“Extended Year End Technical Stop”)

. (Alt *Ir*: Year End Extended Technical stop = “YEETS”)

- EYETS (YETS + 6 weeks= 19 weeks) required by CMS, buys contingency for ALICE and LHCb.
- Extending EYETS to 9.5 months for Linac4 subsequently presented as an option
  - motivation recognized
  - is problematic for the experiments.
  - note the possibility of cable cleanup and preparation for LS2 during this period
- Given EYETS:
  - continue run 2 into 2018 for at least 6 months
  - continue run 2 until end 2018
  - possible compromise 9 months into 2018
- Any of these options naturally leads to a delay of the start of LS3 from 2022 to 2023

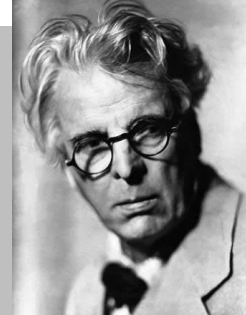

W.B Yeats



## Options presented

- Baseline
  - No EYETS in 2016-17
  - 2018 LS2 (but has to go to 18 months)
  - LS3 starts in 2022
- Slipped baseline+6
  - EYETS in 2016-17 plus continue run 2 to mid-2018
  - 3 year run 3 – LS3 starts in 2023
- Slipped baseline+12
  - EYETS plus continue run 2 to end 2018
  - Slightly shortened run 3 – LS3 starts in 2023



## Planning : further comments (AB)

-Phase 1: consolidations & upgrades underway will help equip expts for cycle of 3-4 operations years including minimal ~ 13 week year end stop, followed by LS of 1-2 years.

**-Phase 2 : ATLAS& CMS will need ~30 month LS3: not effective to stage**

Activation (+ contamination?) serious issue from LS3 onwards .

ALARA to be built into designs & operating procedures from outset  
eg Low intensity runs for cooling + Advance “hot” LS3 activities to end LS2

**-Infrastructure end of lifetime replacements not yet accounted for**

**- in LS3 could seriously disrupt underground work —> advance to LS2 if at all possible**

LS2 timed to allow Phase 2 infra work to be advanced —> help restrict length of LS3

**-1 year shift in LS3 start (to 2023) eases funding profile for Phase 2 upgrades**

-Best to minimise # sequential calendar years without any physics (continuity, headlines)

**Resources: labs, test beams , RP facilities & equipment , simulations, new TAS/shielding needed well in advance —> Joint coord. & executive structures (coord comm + PO)**



## Conclusion

Following the Higgs discovery, the justification for high lumi LHC and a target p-p luminosity of  $3000\text{fb}^{-1}$  is compelling.

Phase 1 consolidations to ATLAS & CMS and major upgrades to ALICE & LHCb (now  $\rightarrow$  end LS2) will allow the present programme to continue effectively for Runs 2,3. ie to initial p-p target of  $300\text{fb}^{-1}$  but with  $\langle\text{PU}\rangle \gg$  nominal ( $\leq 70$ ).

Thereafter, ATLAS and CMS must make major upgrades due to radiation effects which critically damage performance once  $\int\text{Ldt}$  exceeds  $300\text{-}500\text{fb}^{-1}$ .

These Phase 2 upgrades are being designed to allow studies of a broad range of physics, including precision studies of the (low mass) Higgs, at the high pile-up, high radiation dose conditions expected at HL-LHC. (3-4 years R & D + 5-6 years to build)

A realistic schedule over the next decade is essential for correct resource request/allocation. Basic goal is to cost-effectively maximise useful integrated lumi as a function of time.

These are technically very difficult upgrades – getting the resources (including human) needs new models of support from Collaborations & much help from CERN. Support facilities and planning for infrastructure replacement are urgent issues.



**More....**

Additional material

# LHCb upgrades

Main detector replacement concern the tracking system

→ Fast tracking and vertexing will be crucial!

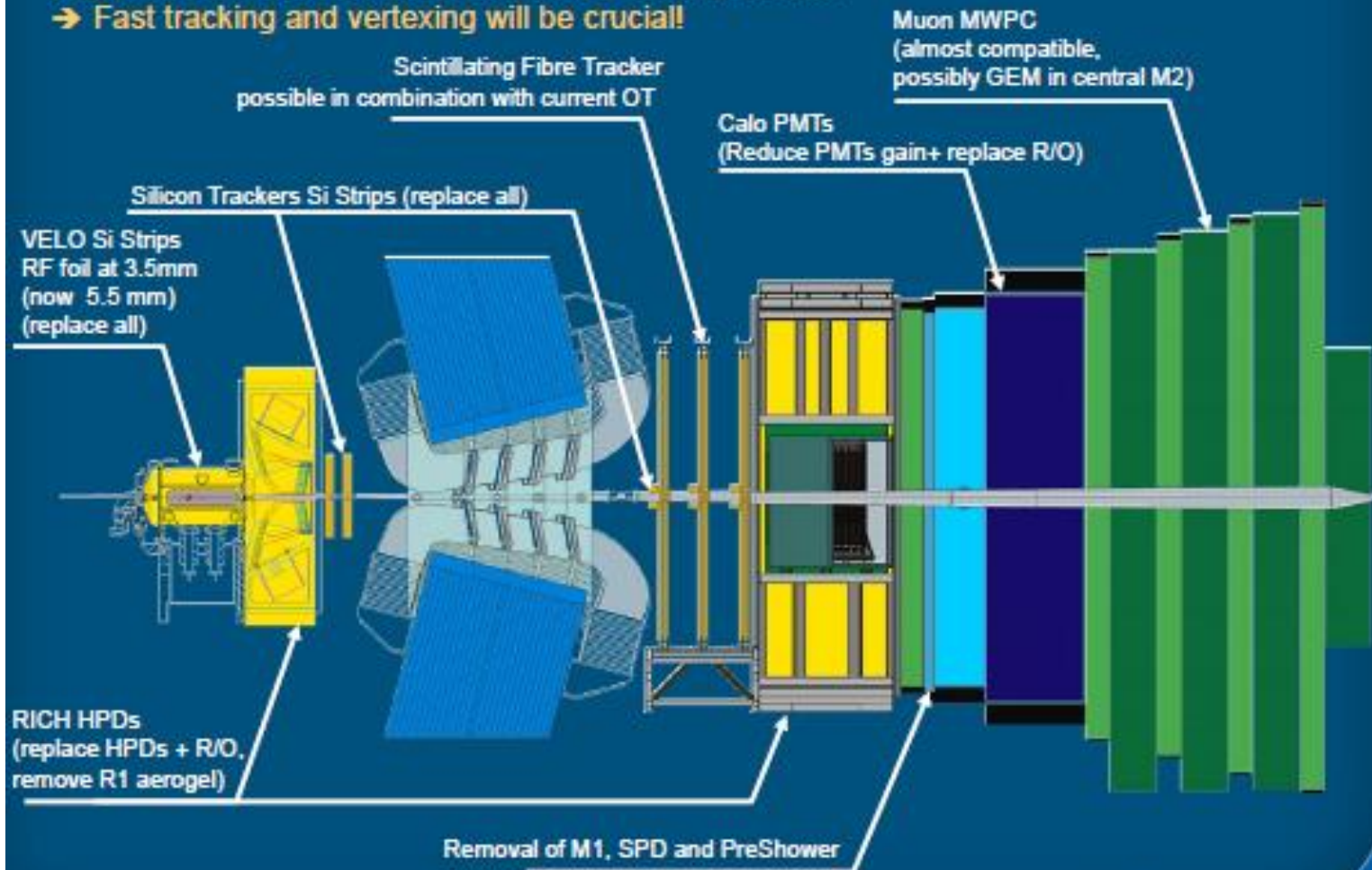



# ALICE upgrades

- New, high-resolution, low-material Inner Tracker System
  - Closer to IP (39mm  $\rightarrow$  22mm), less material and reduced pixel size
- Upgrade of TPC
  - Replacement of MWPCs with GEMs and new pipelined readout electronics
- Upgrade of readout electronics of TRD, TOF, Muon Spectrometer, ZDC
- Upgrade of the forward trigger detectors
- New 5-plane silicon telescope in front of the hadron absorber

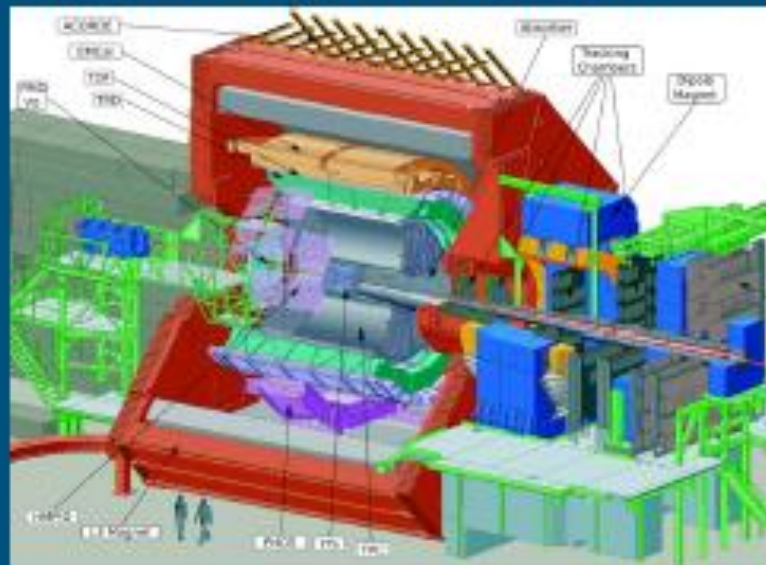

- **LoI and ITS CDR endorsed by LHCC in Sep 2012**  
**MFT as addendum to LOI endorsed by LHCC in Sep 2013**



# Pileup mitigation at High Lumi

- Preliminary studies with CMS Phase 1 detector
  - Tracking acceptance covers flat luminous region
  - No significant tracking efficiency difference at 140 PU
  - Vertex finding efficiency decrease & number of merged vertices increase for Gaussian density
- Track association to primary and secondary vertices will be more efficient with flat density
  - Improved corrections to calorimeter energies
  - Improved b-tagging efficiency. Ex. a 10% gain as shown in right bottom plot will increase 2b-tagging efficiency by ~ 40 %

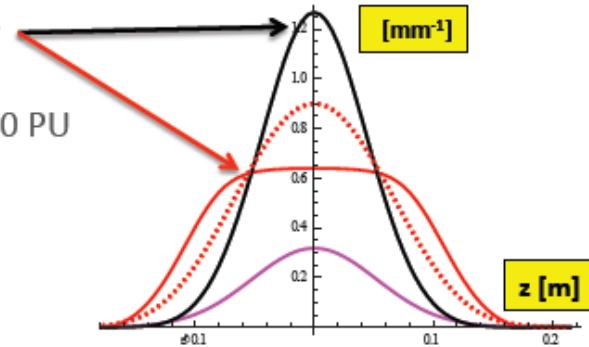

Scenarios of interaction density / crossing  
S. Fartouk presentation at ECFA workshop

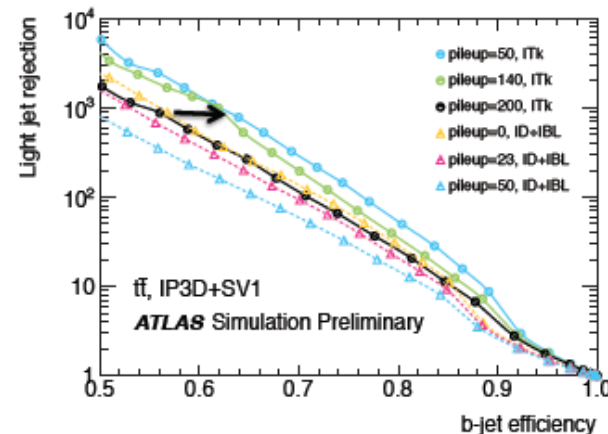
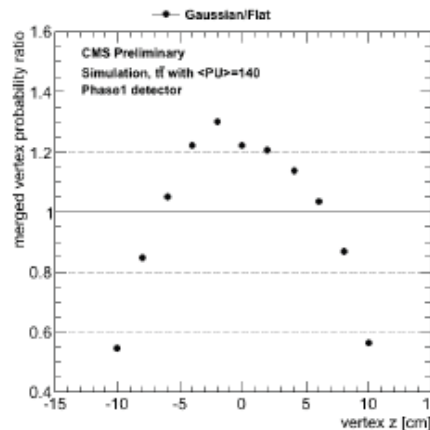
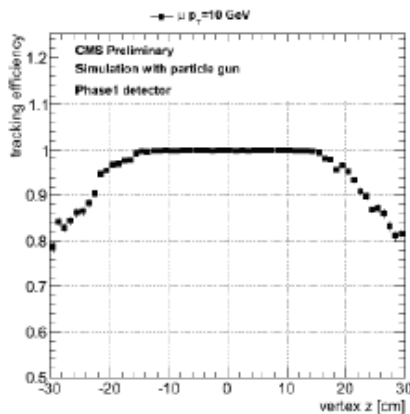

It is essential that Accelerator & Experiments investigate all opportunities to mitigate PU effects to fully profit from the LHC High Luminosity potential