

Experimental particle. physics

esipap...
European School of Instrumentation
in Particle & Astroparticle Physics

4. systems used to
identify and measure
particle properties

What do we want to measure?

... “stable”
particles!

decays?

jets



interaction
modes?

invisible
*in particle
detectors at
accelerators*



interaction
modes?



decays?

Interaction mode recap...



- electrically charged
- ionization (dE/dx)
- electromagnetic shower

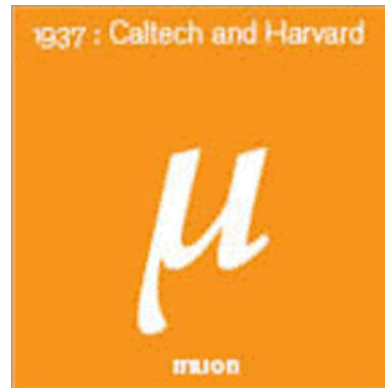

- electrically charged
- ionization (dE/dx)
- can emit photons
 - ✓ electromagnetic shower induced by emitted photon



- electrically neutral
- pair production
 - ✓ $E > 1 \text{ MeV}$
- electromagnetic shower



- produce hadron(s) jets via QCD hadronization process

What should a particle experiment do?

- Tracking
- Momentum and energy measurements
- Neutral particle detection
- Particle identification
- *Trigger*
- *Data acquisition*

Detector	Common uses
Scintillation counter	tracking, fast timing, triggering
Cerenkov counter	particle identification, triggering
Proportional chamber	tracking, triggering
Drift chamber	tracking, particle identification
Sampling calorimeters	neutral particle detection, triggering
Bubble chamber	vertex detector, tracking
Emulsion	high resolution vertex detection
Spark chamber	tracking
Streamer chamber	vertex detector, tracking
Transition radiation detector	high energy particle identification
Semiconductor detector	vertex detector
Flashtube hodoscope	tracking
Spark counter	high resolution timing

How do we “see” particles?

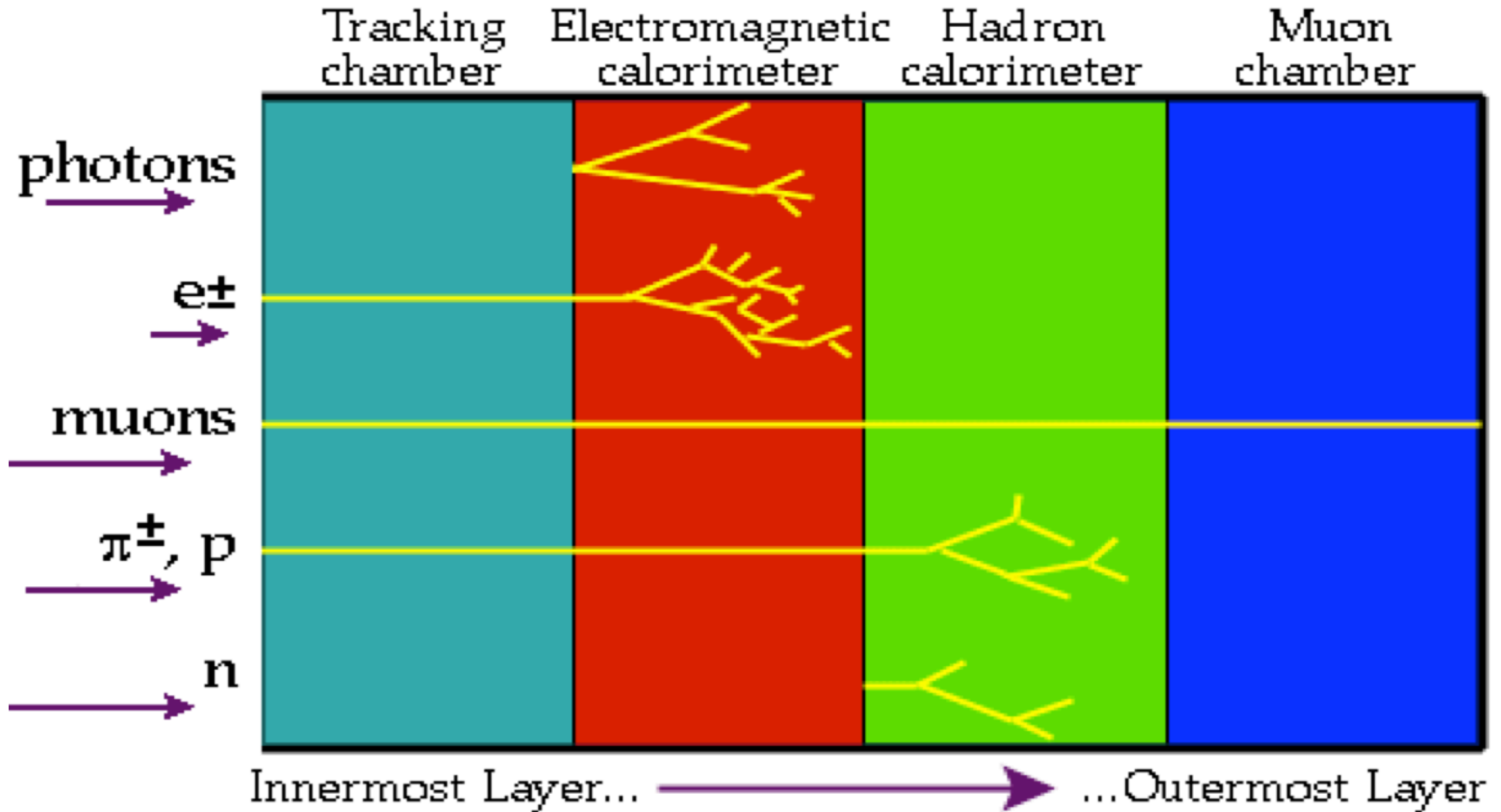

How do we “see” particles?

- Beam Pipe (center)
- Tracking Chamber
- Magnet Coil
- E-M Calorimeter
- Hadron Calorimeter
- Magnetized Iron
- Muon Chambers

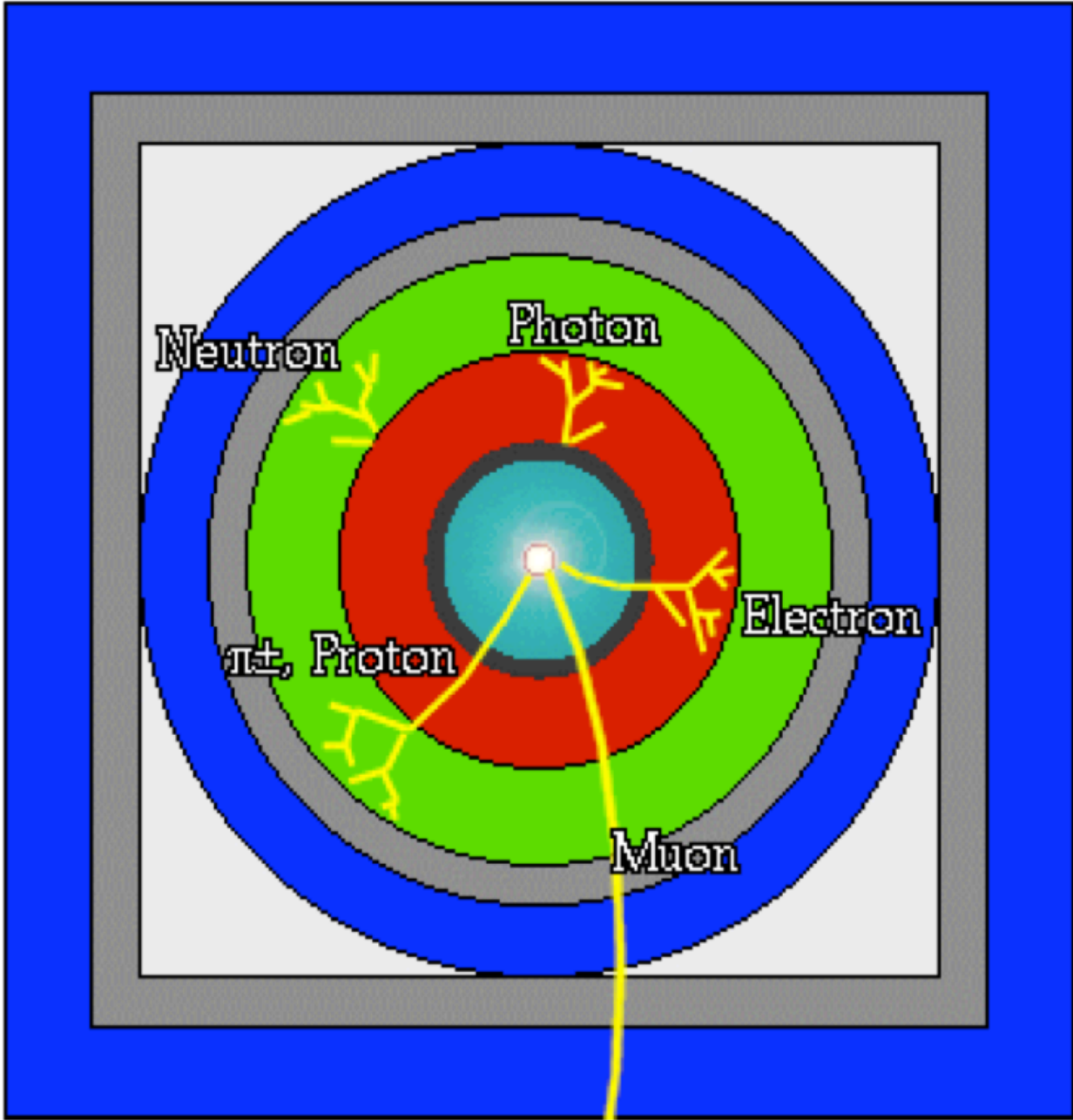

How do we “see” particles?

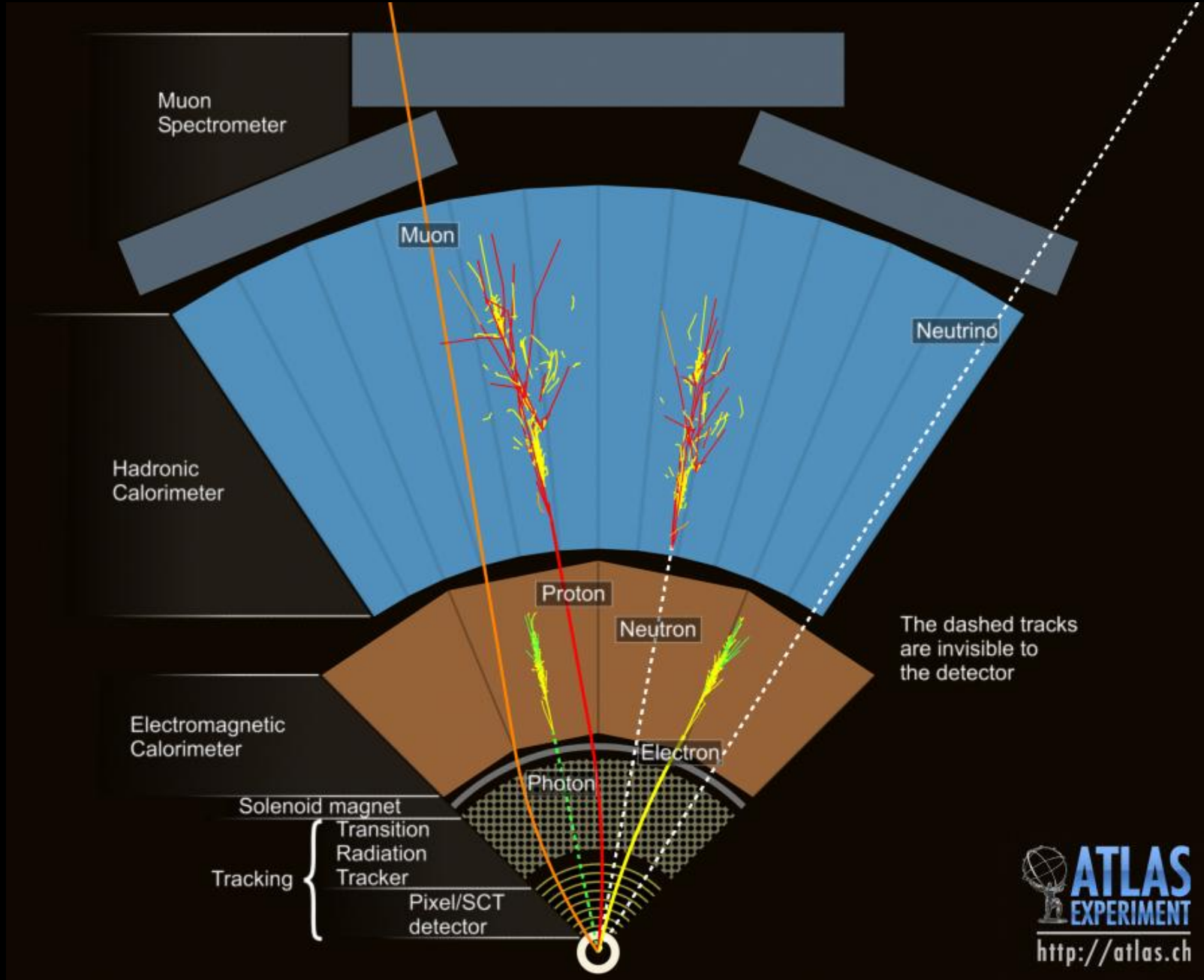

Magnetic spectrometer

- A system to measure (charged) particle momentum
- Tracking device + magnetic field

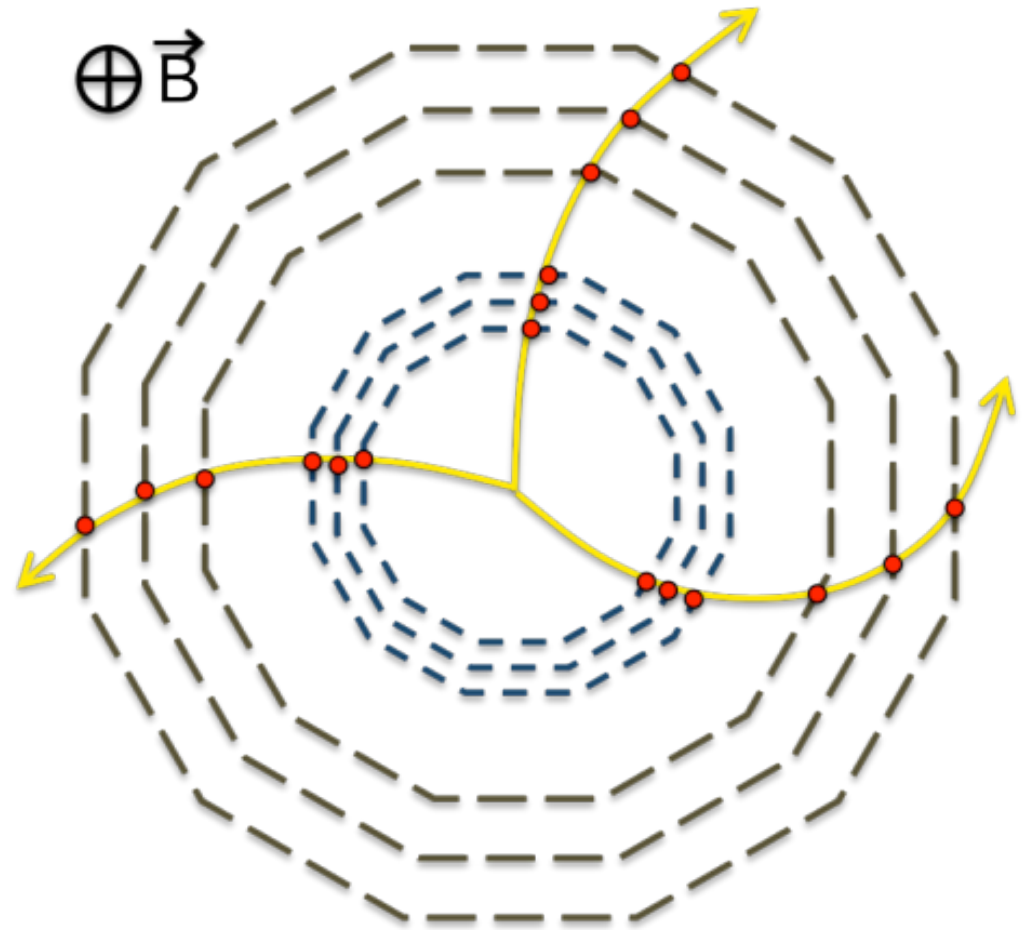
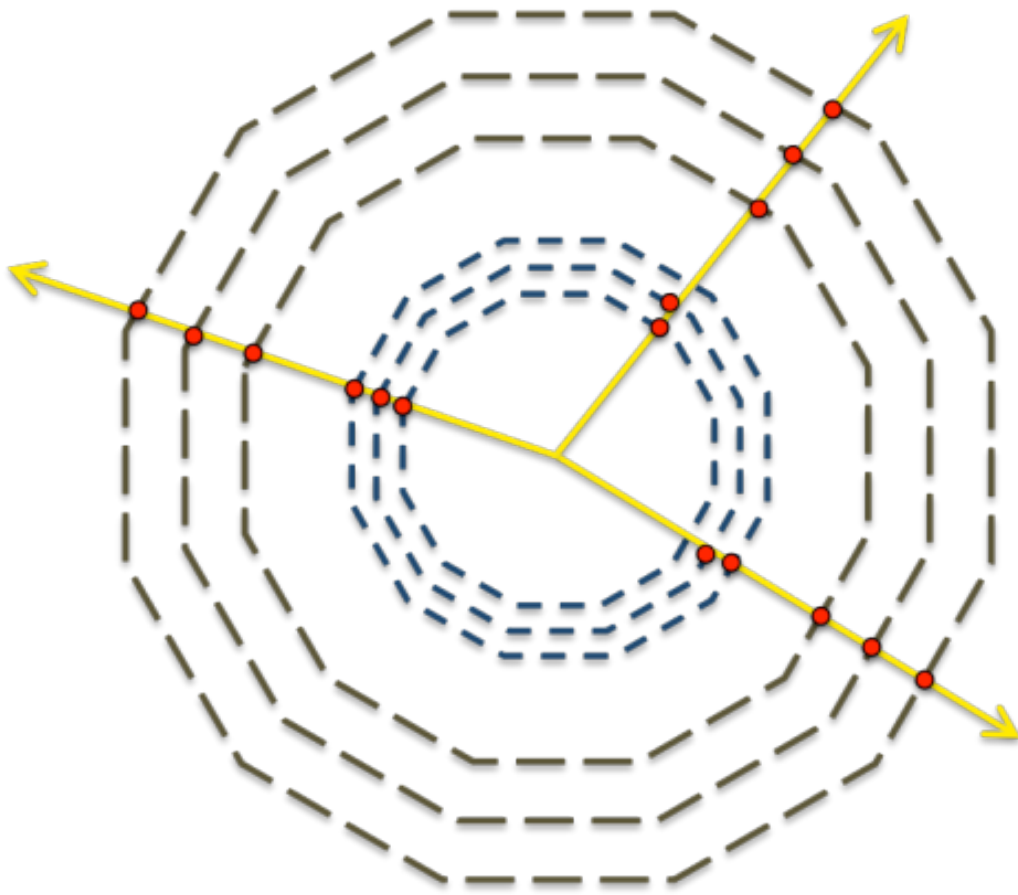

Magnetic spectrometer

Charged particle in
magnetic field

$$\frac{d\vec{p}}{dt} = q\vec{\beta} \times \vec{B}$$

If the field is constant and we neglect presence of matter, **momentum magnitude is constant** with time, **trajectory is helical**

$$p[\text{GeV}] = 0.3B[\text{T}]\rho[\text{m}]$$

Actual trajectory differ from exact helix because of:

- **magnetic field inhomogeneity**
- **particle energy loss** (ionization, multiple scattering)

Momentum measurement

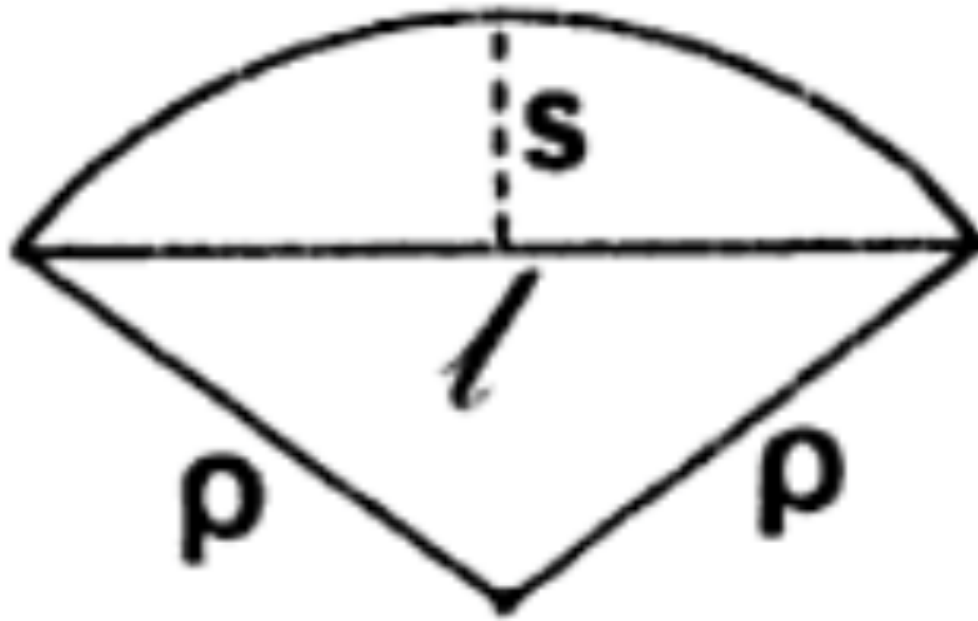

s = sagitta

l = chord

ρ = radius

$$\rho \simeq \frac{l^2}{8s}$$

$$p = 0.3 \frac{Bl^2}{8s}$$

$$\left| \frac{\delta p}{p} \right| = \left| \frac{\delta s}{s} \right|$$

Momentum resolution

smaller for larger number of points *measurement error (RMS)*

Momentum resolution
due to measurement
error

$$\left| \frac{\delta p}{p} \right| = A_N \frac{\epsilon}{L^2} \frac{p}{0.3B}$$

projected track length *resolution is improved faster*
in magnetic field *by increasing L then B*

Momentum resolution gets worse for larger momenta

RMS of projected angle
per unit thickness *~1.43*

Momentum resolution
due to multiple
scattering

$$\left| \frac{\delta p}{p} \right| = \frac{p}{0.3B} \sqrt{\frac{\xi C_N}{L}}$$

Design consideration: magnetic field (collider)

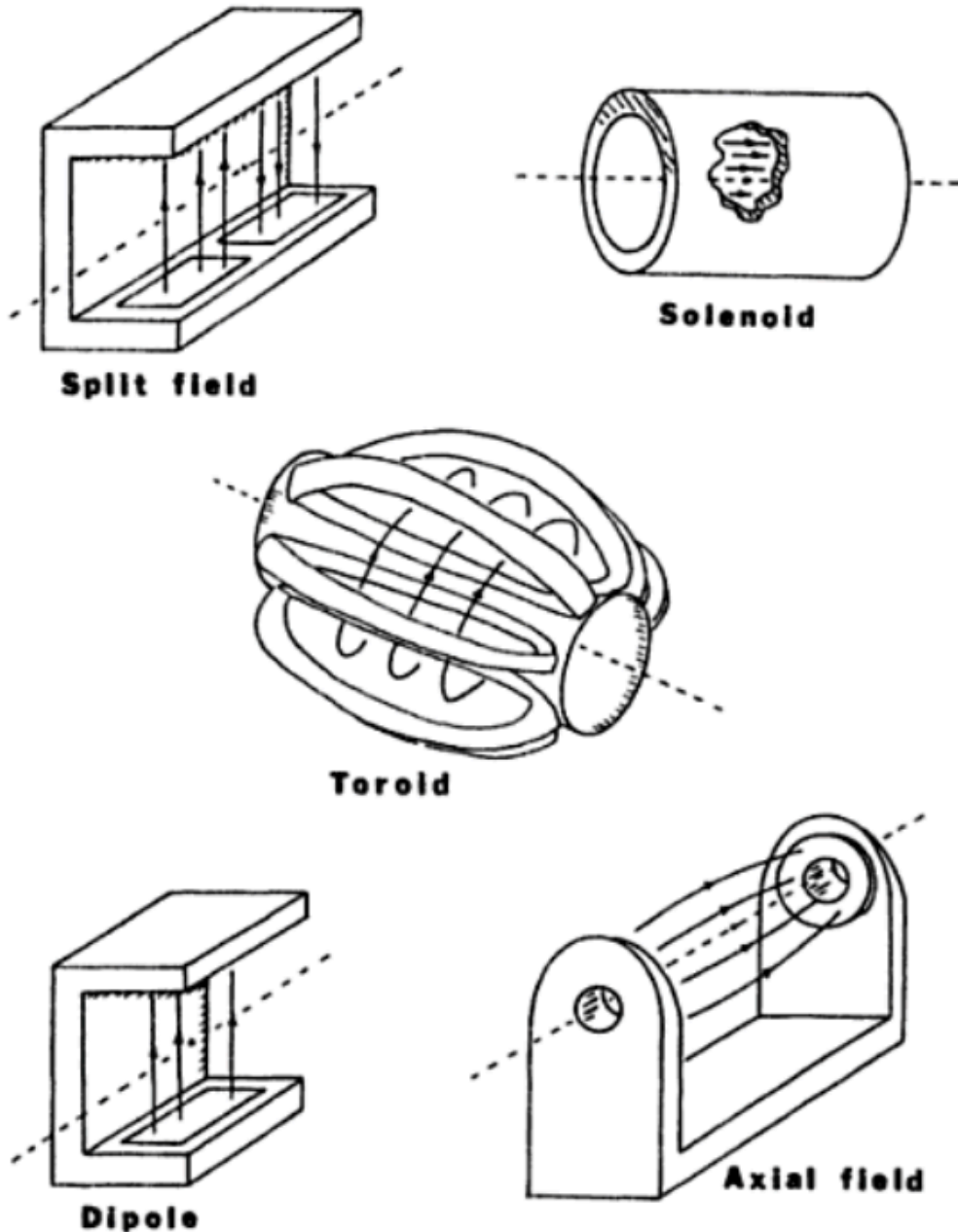

- Field...
 - ✓ should ensure good momentum resolution in region of most importance
 - ✓ Cannot be too high (low p particle would spiral)
 - ✓ Should not interfere too much with beam orbit
 - Compensate deflection with additional magnets...

Design consideration: magnetic field (collider)

	Dipole	Split field magnet	Solenoid	Axial field magnet	Toroid
Return yoke	yes	yes	yes	yes	no
Compensating magnet	yes	no	small	small	no
e^+e^- beams	no	no	yes	yes	yes
Coils before field region	no	no	no	no	yes
High p_t measurement	good	good	poor	good	poor
Forward particle measurement	good	good	poor	poor	poor

Design consideration: tracking devices

- **Inner tracker**

- ✓ Silicon detectors (pixels, microstrips)
 - High resolution vertexing
- ✓ Transition detector trackers
- ✓ TPC Time Projection Chambers

- **Muon spectrometer**

- ✓ Drift chambers
- ✓ MWPC (Multi Wire Proportional Chambers)
- ✓ RPC (Resistive Plate Chambers)

Semiconductor detectors

ATLAS Pixel Detector

[Details]

Pixel Sensor

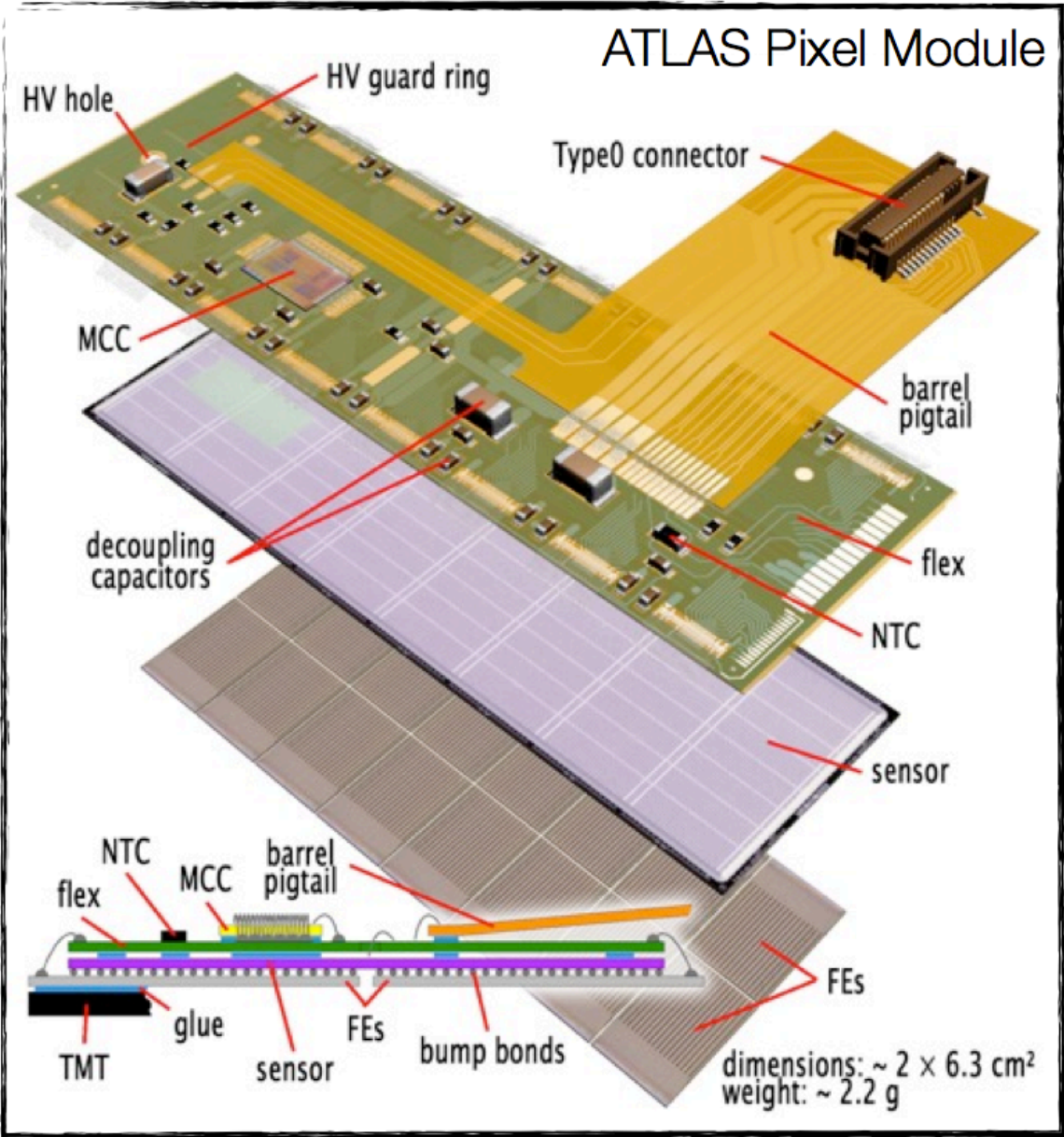
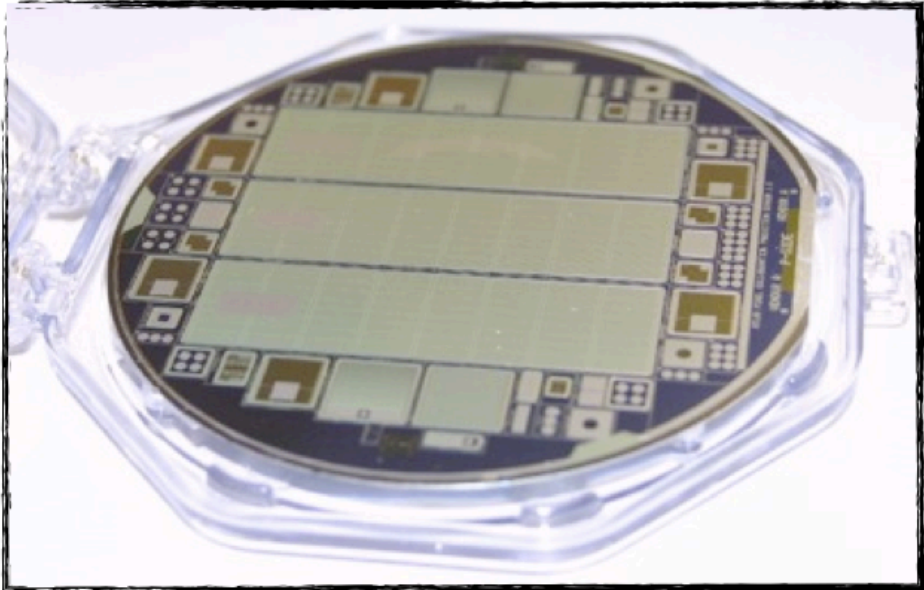

Semiconductor detectors

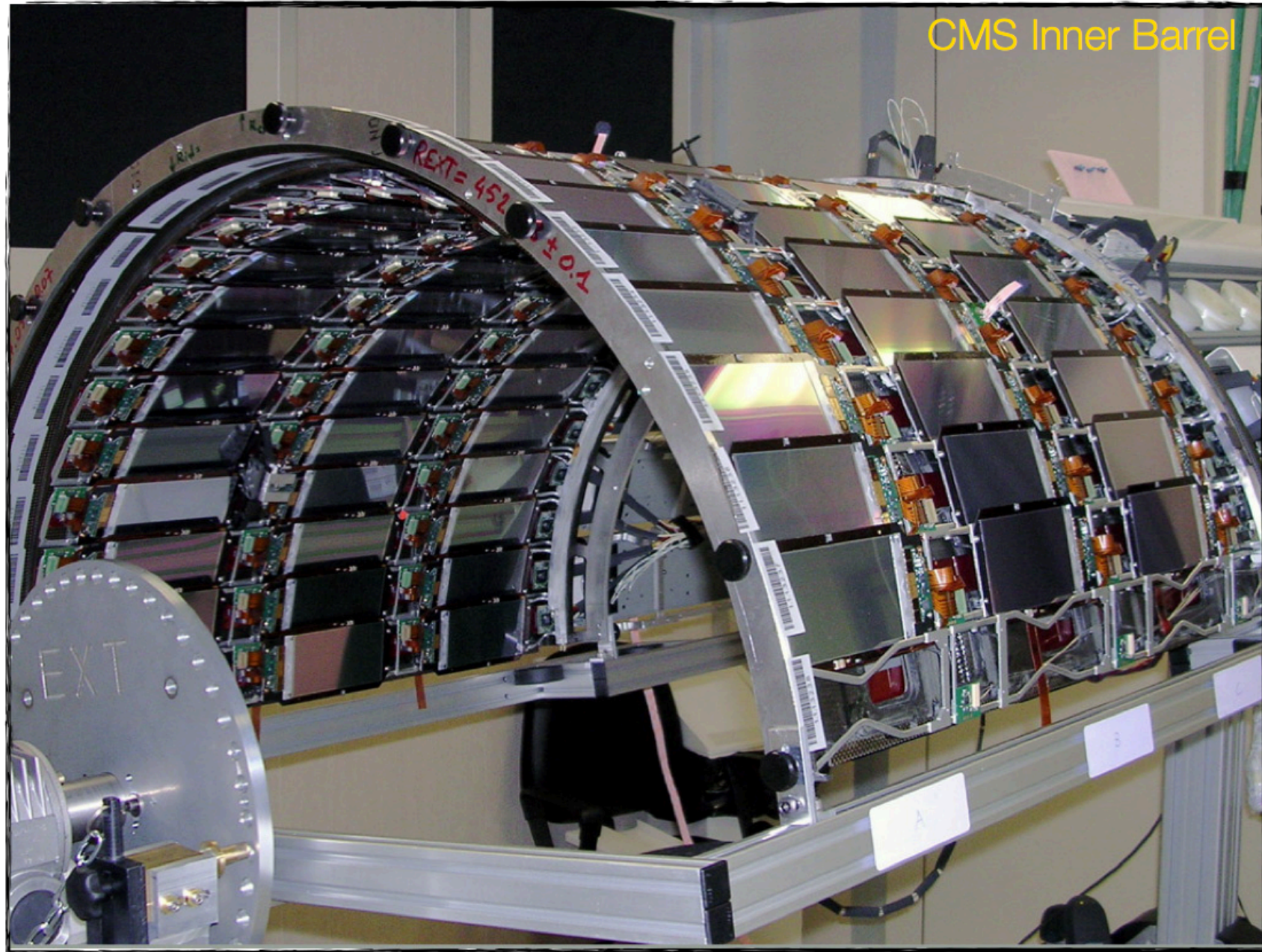

TPC principles of operation

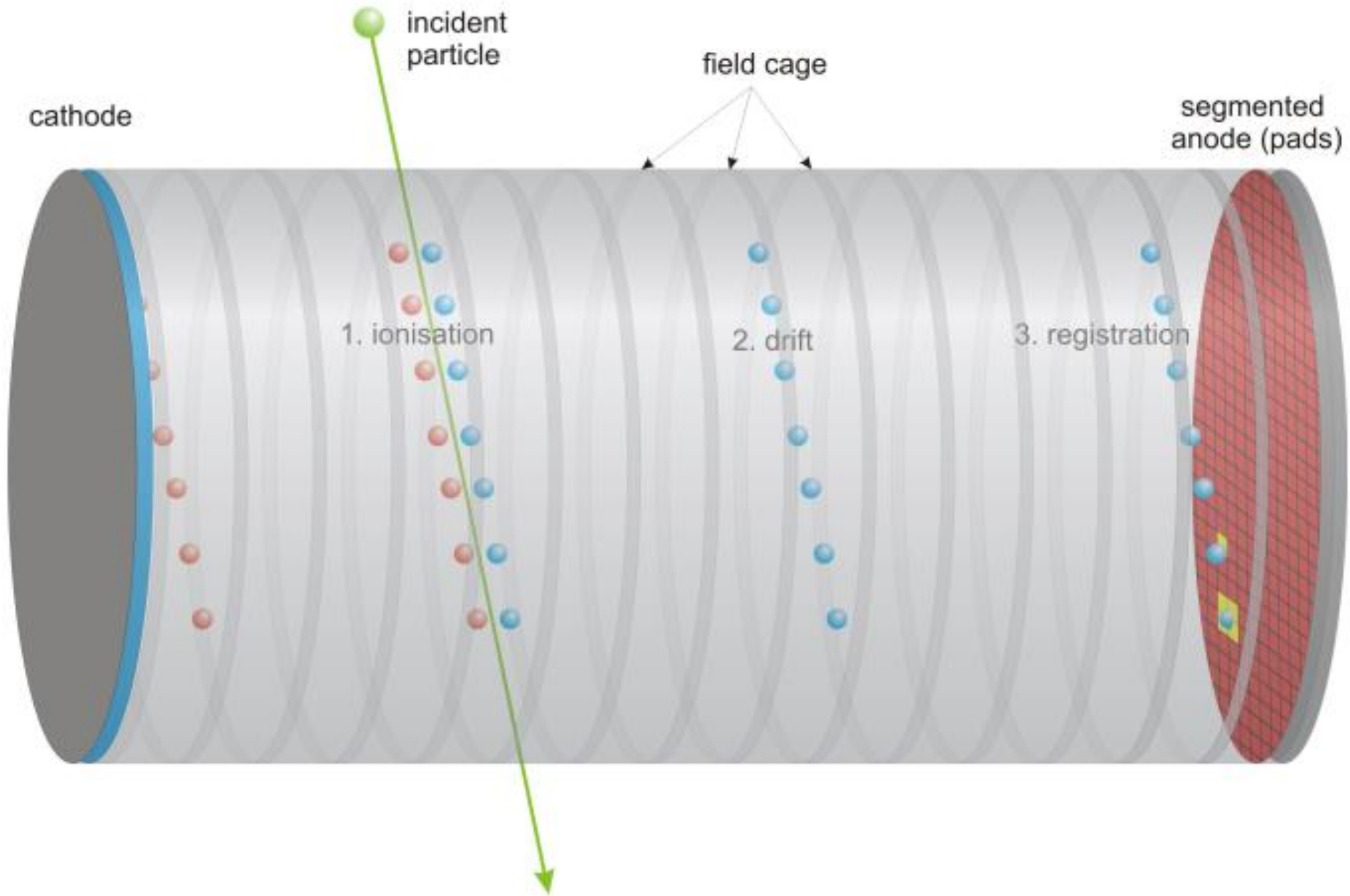

ALICE TPC

ALICE TPC:

Length: 5 meter
Radius: 2.5 meter
Gas volume: 88 m³

Total drift time: 92 μ s
High voltage: 100 kV

End-cap detectors: 32 m²
Readout pads: 557568
159 samples radially
1000 samples in time

Gas: Ne/CO₂/N₂ (90-10-5)
Low diffusion (cold gas)

Gain: > 10⁴

Diffusion: $\sigma_t = 250 \mu\text{m}$
Resolution: $\sigma \approx 0.2 \text{ mm}$

$\sigma_p/p \sim 1\%$; $\epsilon \sim 97\%$
 $\sigma_{dE/dx}/(dE/dx) \sim 6\%$

Magnetic field: 0.5 T

Pad size: 5x7.5 mm² (inner)
6x15 mm² (outer)

Temperature control: 0.1 K
[also resistors ...]

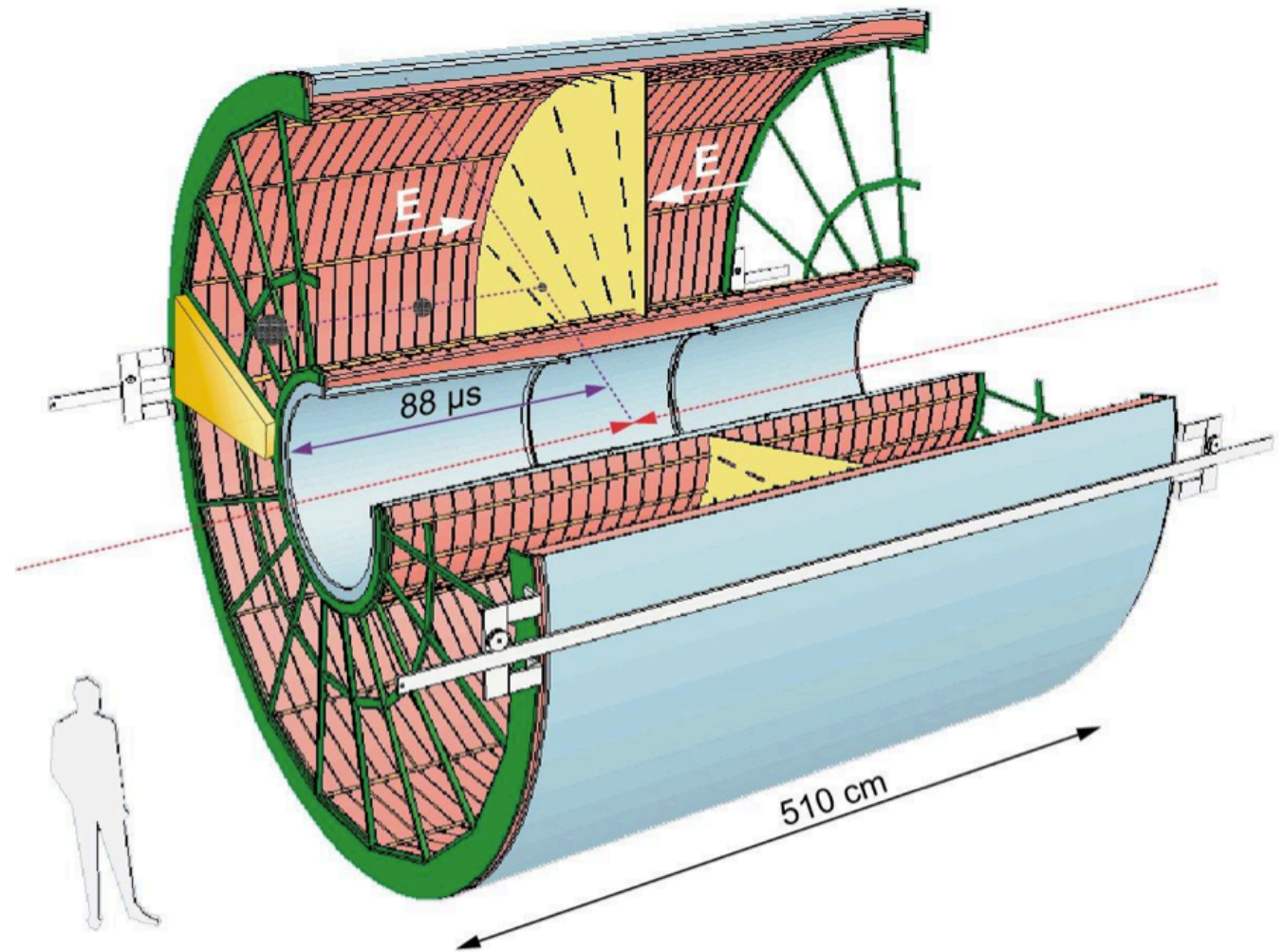

Material: Cylinder build from composite material of airline industry ($X_0 \sim 3\%$)

LHC outer tracker

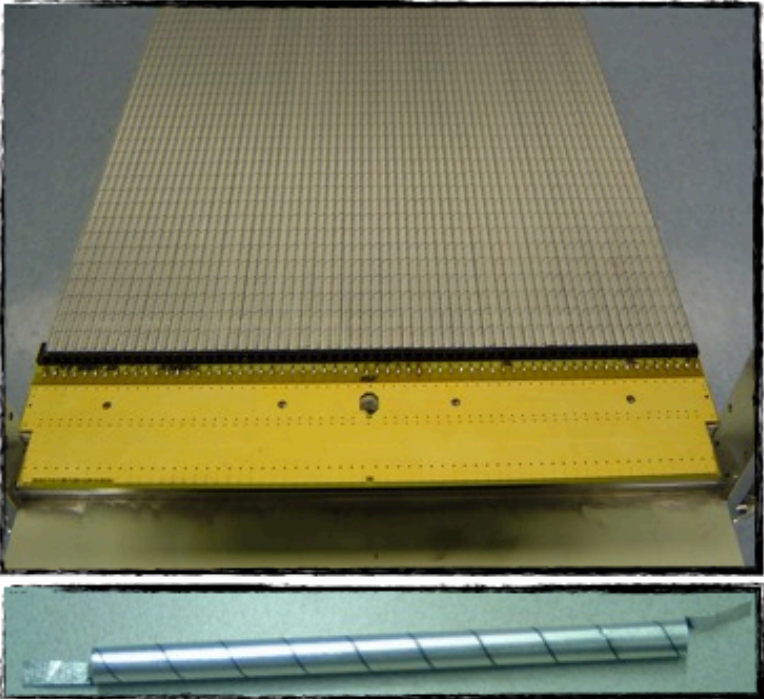
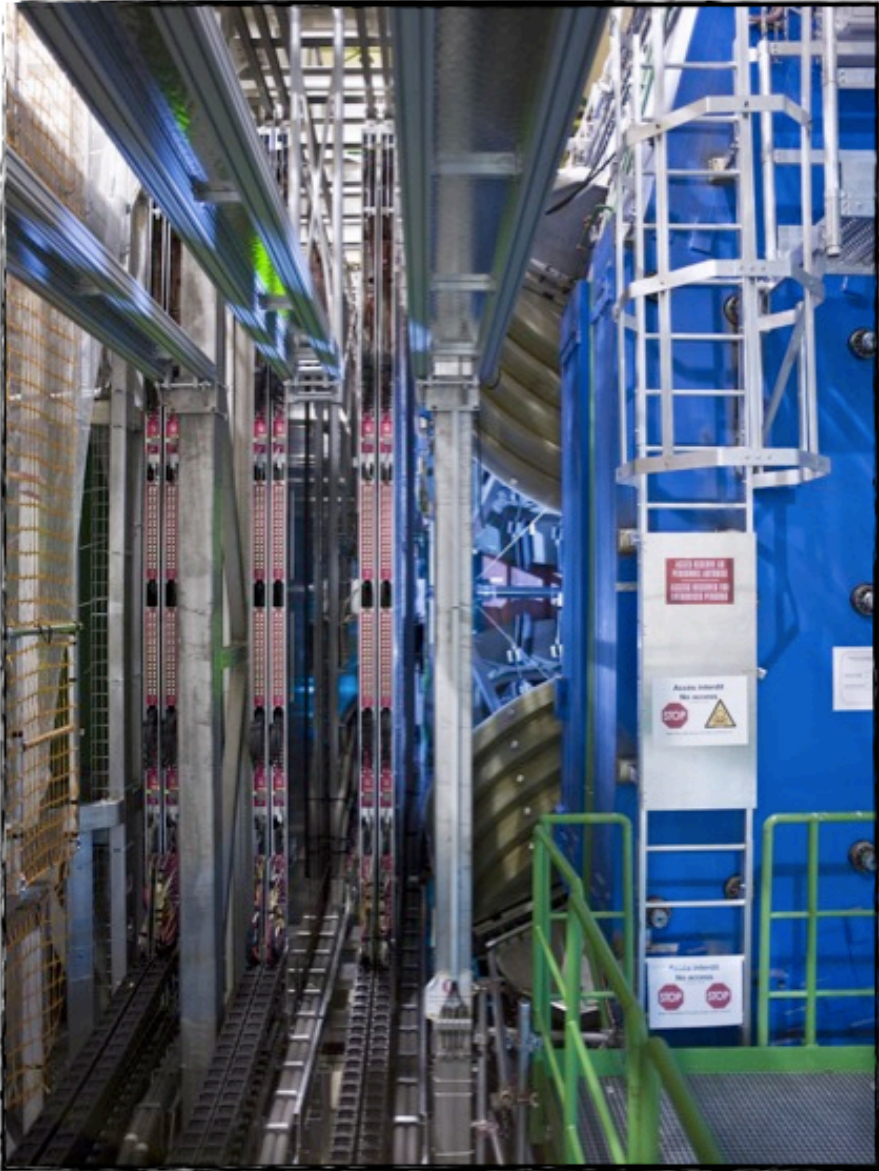
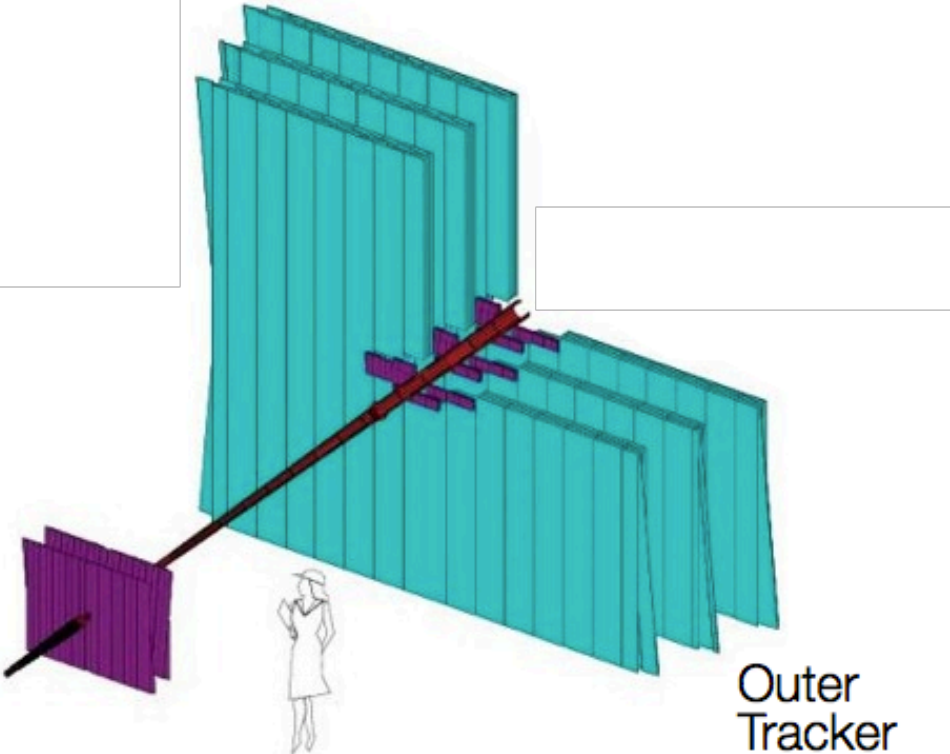

Straw Tubes
[double layers]

3 Chambers
[4 layers á 18 modules]

LHC outer tracker

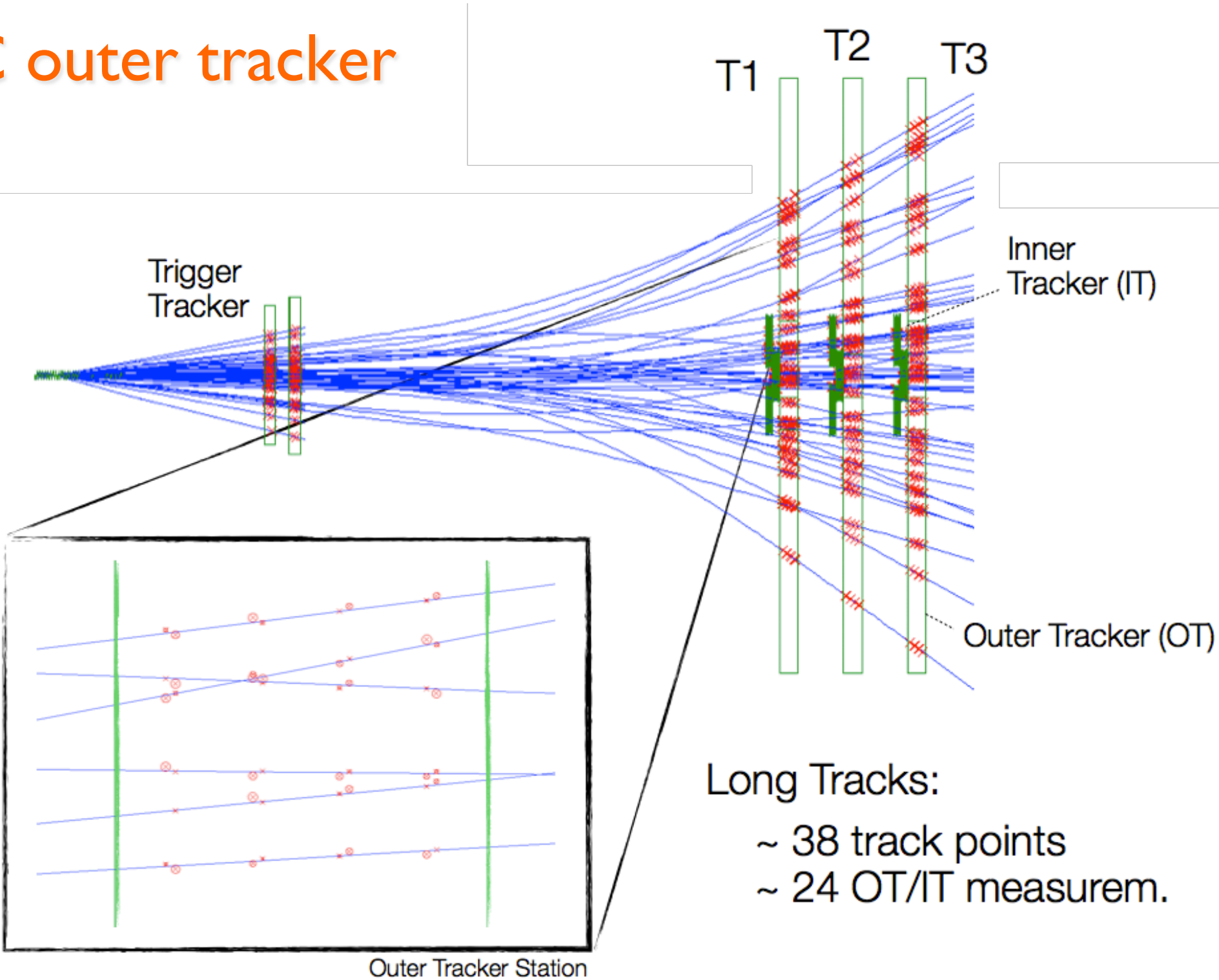

Long Tracks:
~ 38 track points
~ 24 OT/IT measurement.

Outer Tracker Station

Calorimetry

- **Detector for energy measurement via total absorption of particles**
- **Principles of operation**
 - ✓ Incoming particle initiates particle shower
 - Electromagnetic, hadronic
 - Shower properties depend on particle type and detector material
 - ✓ Energy is deposited in active regions
 - Heat, ionization, atom excitation (scintillation), Cherenkov light
 - Different calorimeters use different kind of signals
 - ✓ Signal is proportional to energy released
 - Proportionally \rightarrow calibration
 - Shower containment

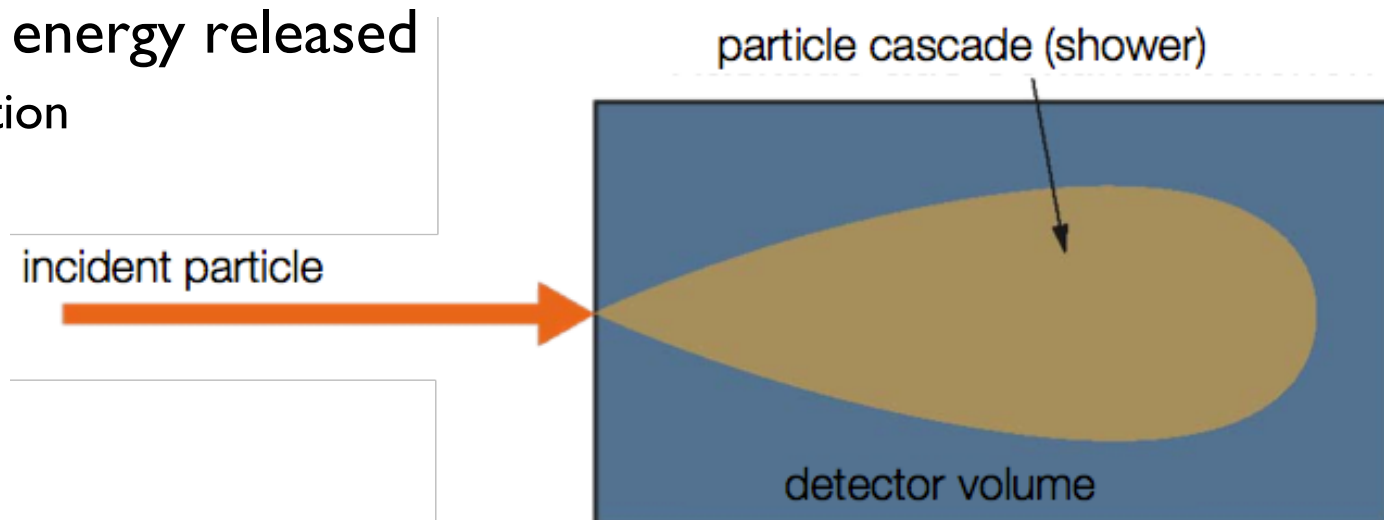

Calorimeters can...

- **Calorimeters can be built as 4π -detectors**
 - ✓ They can detect particles over almost the full solid angle
 - ✓ Magnetic spectrometer: anisotropy due to magnetic field

$$\left(\frac{\sigma_p}{p}\right)^2 = \left(\frac{\sigma_{p_T}}{p_T}\right)^2 + \left(\frac{\sigma_\theta}{\sin\theta}\right)^2$$

- **Calorimeters are often also sensitive to particle position**
 - ✓ Important for neutral particles: no track in inner detector!
- **Calorimeters can provide fast timing signal**
 - ✓ 0.1 to 10 ns
 - ✓ They can be used for triggering!
- **Calorimeters can measure the energy of both charged and neutral particles**
 - ✓ Magnetic spectrometer: only charged particles!
- **Segmentation in depth allows particles separation**
 - ✓ e.g. separate hadrons from particles which only interact electromagnetically

Energy resolution

Calorimeter energy resolution determined by fluctuations ...

Homogeneous calorimeters:

Shower fluctuations	}	Quantum fluctuations
Photo-electron statistics		
Shower leakage		
Instrumental effects (noise, light attenuation, non-uniformity)		

In addition for

Sampling calorimeters:

Sampling fluctuations
Landau fluctuations
Track length fluctuations

$$\frac{\sigma_E}{E} = \frac{a}{\sqrt{E}} \oplus \frac{b}{E} \oplus c$$

Quantum fluctuations	$\sim 1/\sqrt{E}$
Electronic noise	$\sim 1/E$
Shower leakage*	$\approx \text{const}$
Sampling fluctuations	$\sim 1/\sqrt{E}$
Landau fluctuations	$\sim 1/\sqrt{E}$
Track length fluctuations	$\sim 1/\sqrt{E}$

* Different for longitudinal and lateral leakage ...
Complicated; small energy dependence ...

Energy resolution

Shower fluctuations: [intrinsic resolution]

Ideal (homogeneous) calorimeter without leakage: energy resolution limited only by statistical fluctuations of the number N of shower particles ...

i.e.:

$$\frac{\sigma_E}{E} \propto \frac{\sigma_N}{N} \approx \frac{\sqrt{N}}{N} = \frac{1}{\sqrt{N}} \quad \text{with } N = \frac{E}{W}$$

$$\frac{\sigma_E}{E} \propto \sqrt{\frac{W}{E}}$$

E : energy of primary particle
 W : mean energy required to produce 'signal quantum'

Examples:

Silicon detectors : $W \approx 3.6$ eV
Gas detectors : $W \approx 30$ eV
Plastic scintillator : $W \approx 100$ eV

Resolution improves due to correlations between fluctuations

$$\frac{\sigma_E}{E} \propto \sqrt{\frac{FW}{E}}$$

[F: Fano factor]

Impact of shower leakage

Shower leakage:

Fluctuations due to finite size of calorimeter; shower not fully contained ...

Lateral leakage: limited influence

Longitudinal leakage: strong influence

Typical expression when including leakage effects:

$$\frac{\sigma_E}{E} \propto \left(\frac{\sigma_E}{E} \right)_{f=0} \cdot \left[1 + 2f\sqrt{E} \right]$$

[f : average fraction of shower leakage]

Remark: other parameterizations exist ...

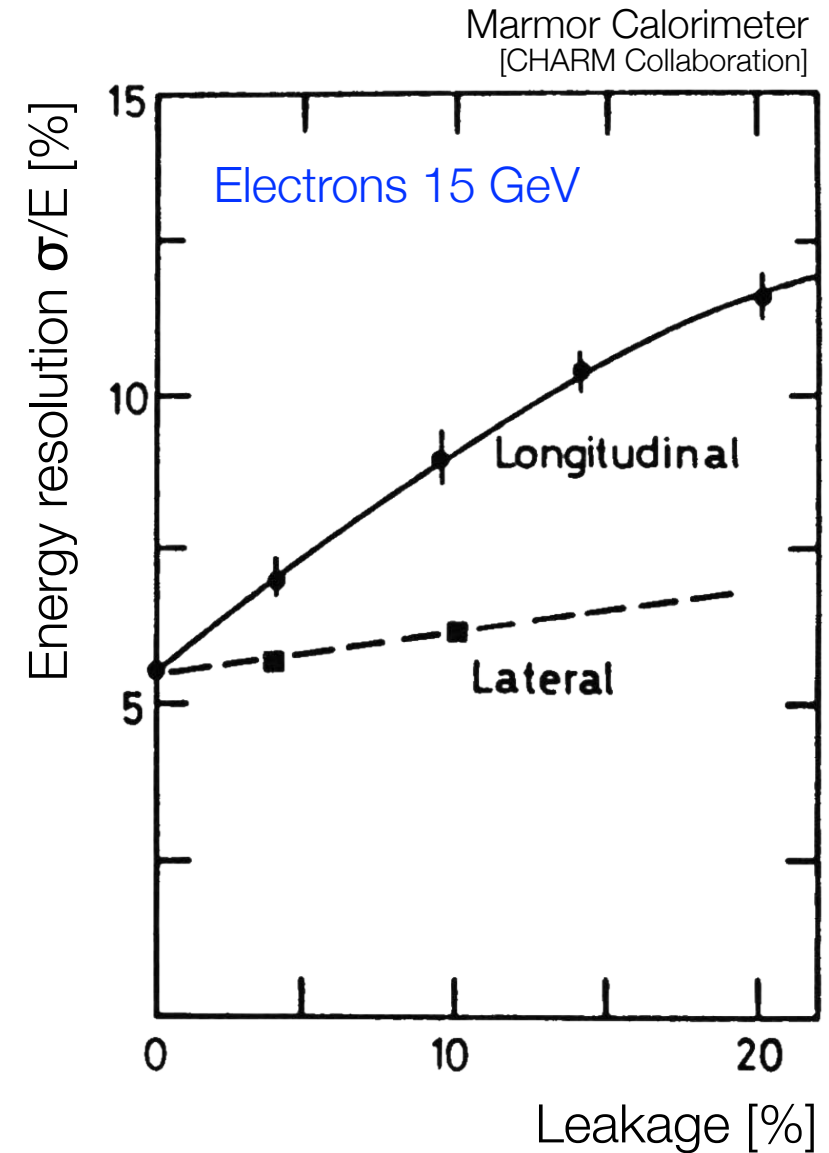

Energy vs. momentum

Energy vs. momentum measurement:

Calorimeter: $\frac{\sigma_E}{E} \sim \frac{1}{\sqrt{E}}$
[see below]

e.g. ATLAS:

$$\frac{\sigma_E}{E} \approx \frac{0.1}{\sqrt{E}}$$

i.e. $\sigma_E/E = 1\% @ 100 \text{ GeV}$

Gas detector: $\frac{\sigma_p}{p} \sim p$
[see above]

e.g. ATLAS:

$$\frac{\sigma_p}{p} \approx 5 \cdot 10^{-4} \cdot p_t$$

i.e. $\sigma_p/p = 5\% @ 100 \text{ GeV}$

At very high energies one has to switch to calorimeters because their resolution improves while those of a magnetic spectrometer decreases with E ...

Shower depth:

Calorimeter: $L \sim \ln \frac{E}{E_c}$
[see below]
[E_c : critical energy]

Shower depth nearly energy independent
i.e. calorimeters can be compact ...

Compare with magnetic spectrometer: $\sigma_p/p \sim p/L^2$
Detector size has to grow quadratically to maintain resolution

Homogeneous calorimeters

- ★ In a homogeneous calorimeter the whole detector volume is filled by a high-density material which simultaneously serves as absorber as well as as active medium ...

Signal	Material
Scintillation light	BGO, BaF ₂ , CeF ₃ , ...
Cherenkov light	Lead Glass
Ionization signal	Liquid noble gases (Ar, Kr, Xe)

- ★ Advantage: homogeneous calorimeters provide optimal energy resolution
- ★ Disadvantage: very expensive
- ★ Homogeneous calorimeters are exclusively used for electromagnetic calorimeter, i.e. energy measurement of electrons and photons

Sampling calorimeters

Principle:

Alternating layers of absorber and active material [sandwich calorimeter]

Absorber materials:
[high density]

Iron (Fe)

Lead (Pb)

Uranium (U)

[For compensation ...]

Active materials:

Plastic scintillator

Silicon detectors

Liquid ionization chamber

Gas detectors

Scheme of a sandwich calorimeter

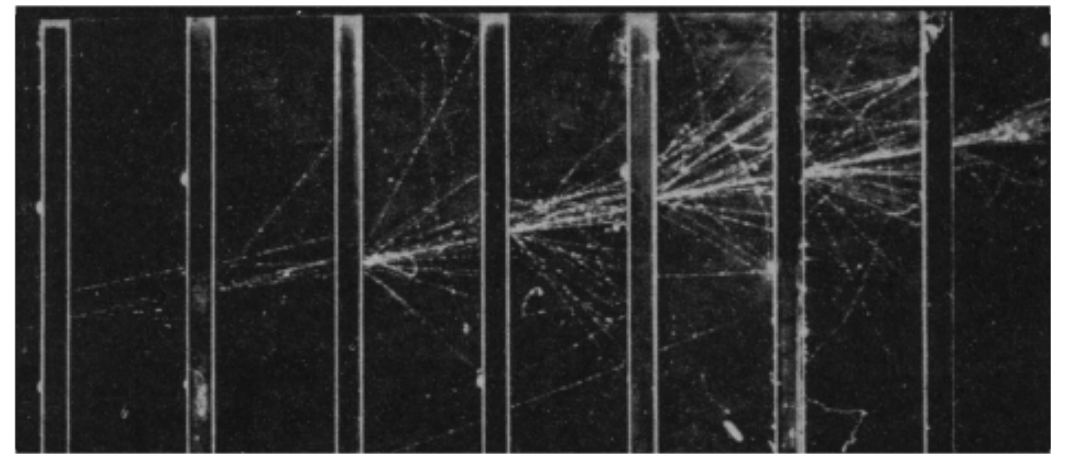
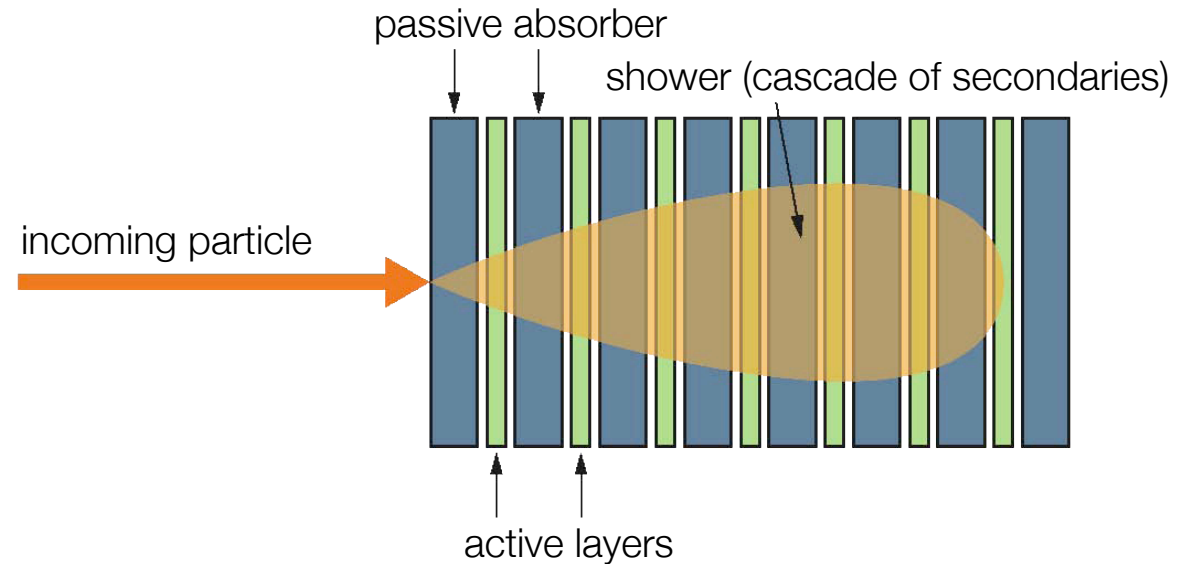

Electromagnetic shower

Sampling calorimeters

★ Advantages:

By separating passive and active layers the different layer materials can be optimally adapted to the corresponding requirements ...

By freely choosing high-density material for the absorbers one can built very compact calorimeters ...

Sampling calorimeters are simpler with more passive material and thus cheaper than homogeneous calorimeters ...

★ Disadvantages:

Only part of the deposited particle energy is actually detected in the active layers; typically a few percent [for gas detectors even only $\sim 10^{-5}$] ...

Due to this sampling-fluctuations typically result in a reduced energy resolution for sampling calorimeters ...

Sampling calorimeters

Scintillators as active layer;
signal readout via photo multipliers

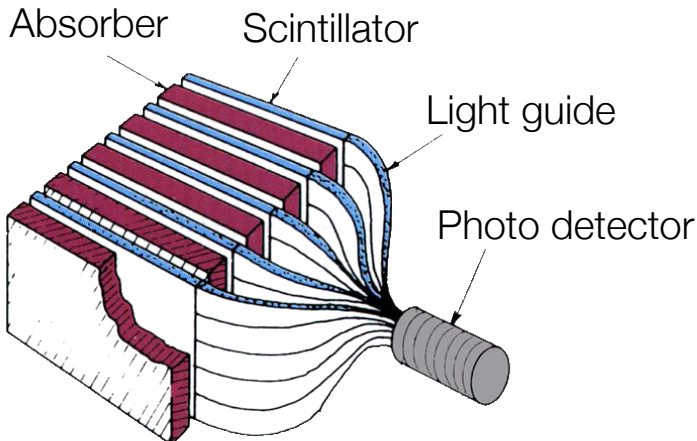

Scintillators as active layer; wave length shifter to convert light

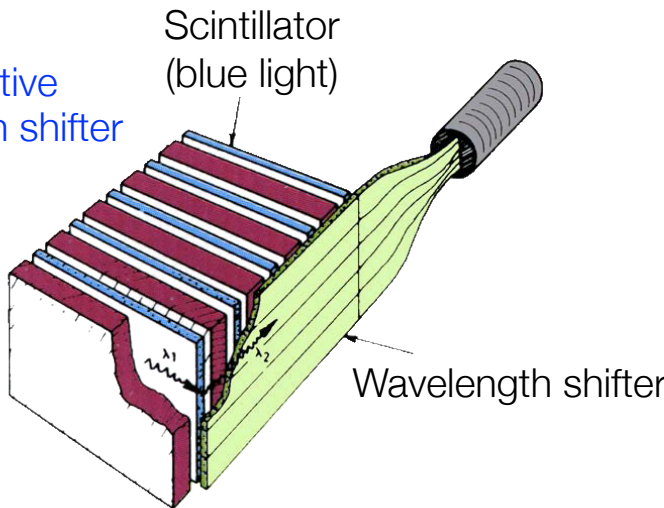

Charge amplifier
Absorber as electrodes

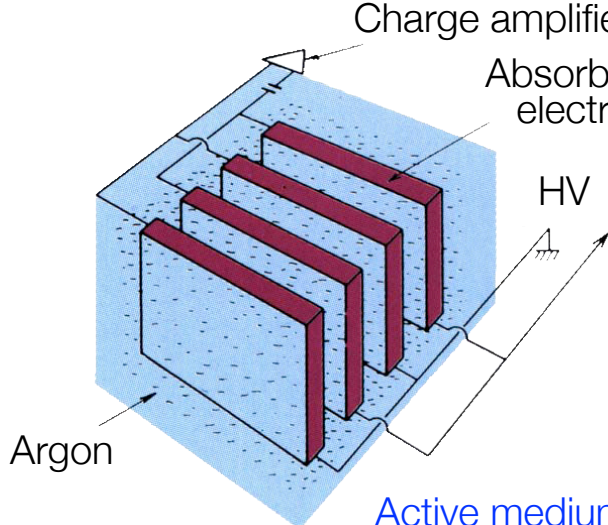

Active medium: LAr; absorber embedded in liquid serve as electrods

Ionization chambers between absorber plates

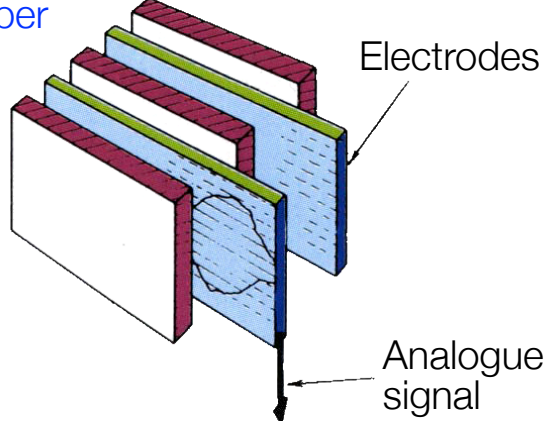

Possible setups

Homogeneous vs. sampling calorimeters

Technology (Experiment)	Depth	Energy resolution	Date
NaI(Tl) (Crystal Ball)	$20X_0$	$2.7\%/E^{1/4}$	1983
Bi ₄ Ge ₃ O ₁₂ (BGO) (L3)	$22X_0$	$2\%/ \sqrt{E} \oplus 0.7\%$	1993
CsI (KTeV)	$27X_0$	$2\%/ \sqrt{E} \oplus 0.45\%$	1996
CsI(Tl) (BaBar)	$16-18X_0$	$2.3\%/E^{1/4} \oplus 1.4\%$	1999
CsI(Tl) (BELLE)	$16X_0$	1.7% for $E_\gamma > 3.5$ GeV	1998
PbWO ₄ (PWO) (CMS)	$25X_0$	$3\%/ \sqrt{E} \oplus 0.5\% \oplus 0.2/E$	1997
Lead glass (OPAL)	$20.5X_0$	$5\%/ \sqrt{E}$	1990
Liquid Kr (NA48)	$27X_0$	$3.2\%/ \sqrt{E} \oplus 0.42\% \oplus 0.09/E$	1998
Scintillator/depleted U (ZEUS)	$20-30X_0$	$18\%/ \sqrt{E}$	1988
Scintillator/Pb (CDF)	$18X_0$	$13.5\%/ \sqrt{E}$	1988
Scintillator fiber/Pb spaghetti (KLOE)	$15X_0$	$5.7\%/ \sqrt{E} \oplus 0.6\%$	1995
Liquid Ar/Pb (NA31)	$27X_0$	$7.5\%/ \sqrt{E} \oplus 0.5\% \oplus 0.1/E$	1988
Liquid Ar/Pb (SLD)	$21X_0$	$8\%/ \sqrt{E}$	1993
Liquid Ar/Pb (H1)	$20-30X_0$	$12\%/ \sqrt{E} \oplus 1\%$	1998
Liquid Ar/depl. U (DØ)	$20.5X_0$	$16\%/ \sqrt{E} \oplus 0.3\% \oplus 0.3/E$	1993
Liquid Ar/Pb accordion (ATLAS)	$25X_0$	$10\%/ \sqrt{E} \oplus 0.4\% \oplus 0.3/E$	1996

Homogeneous

Sampling

Resolution of typical
electromagnetic calorimeter
[E is in GeV]

Particle identification with tracker and calo

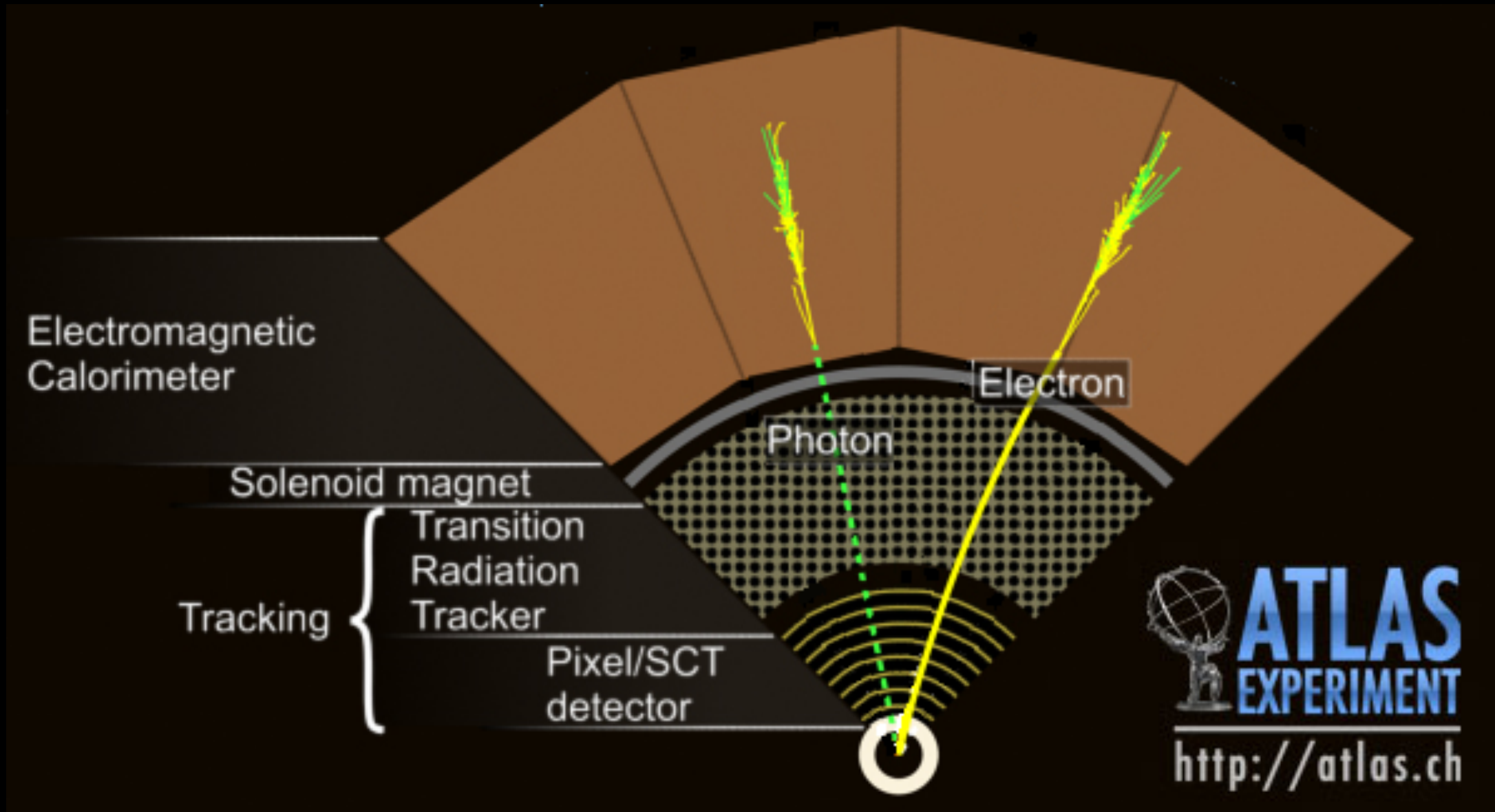

Hadronic calorimeters

Most common realization: **Sampling Calorimeter**

Utilization of homogenous calorimeters unnecessary (and thus too expensive) due to fluctuations of invisible shower components ...

Typical absorbers : Fe, Pb, U ...

Sampling elements : Scintillators, LAr, MWPCs ...

Typical setup:

Alternating layers of active and passive material
[also: 'spaghetti' or 'shashlik' calorimeter]

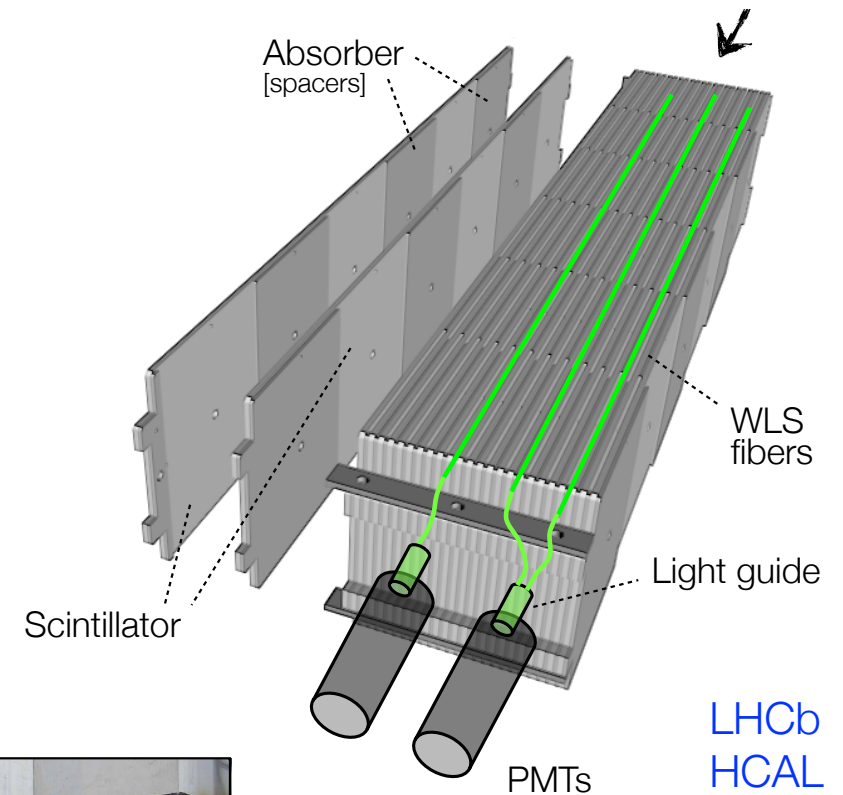
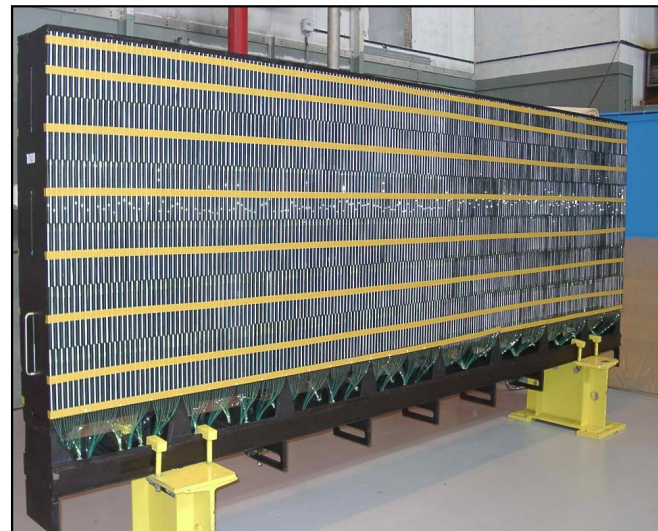
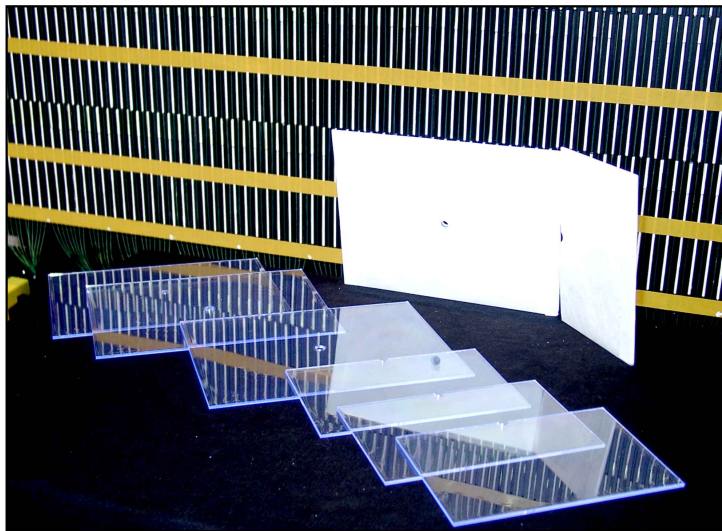

LHCb
HCAL

Example:
LHCb Hadron Calorimeter

Energy resolution

Energy resolution:

e.g. inhomogeneities
shower leakage

e.g. electronic noise
sampling fraction variations

$$\frac{\sigma_E}{E} = \frac{A}{\sqrt{E}} \oplus B \oplus \frac{C}{E}$$

Fluctuations:

- Sampling fluctuations
- Leakage fluctuations
- Fluctuations of electromagnetic fraction
- Nuclear excitations, fission, binding energy fluctuations ...
- Heavily ionizing particles

Typical:

A: 0.5 – 1.0 [Record:0.35]

B: 0.03 – 0.05

C: few %

Resolution: EM vs. HAD

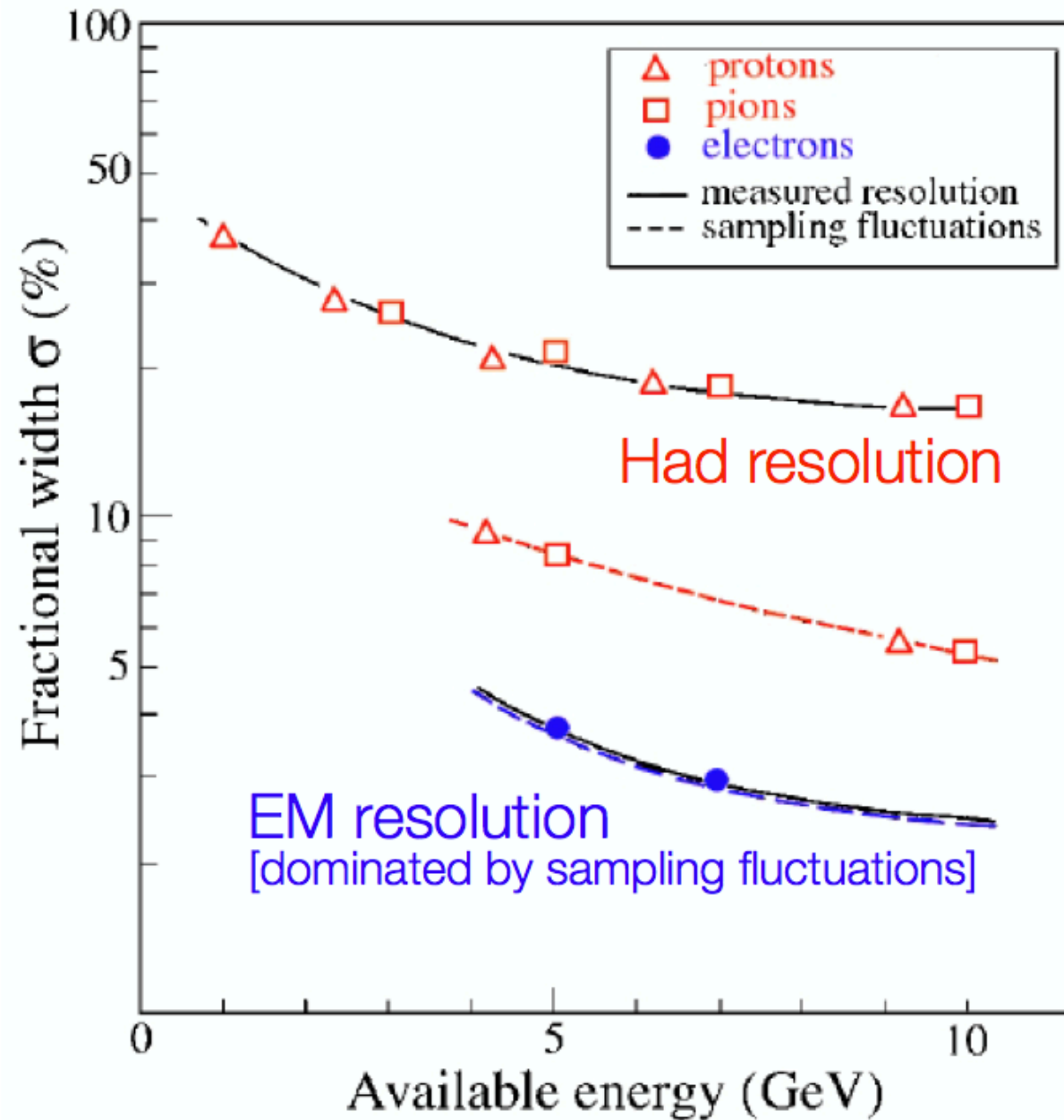

Sampling fluctuations only minor contribution to hadronic energy resolution

[AFM Collaboration]

A typical HEP calorimetry system

Typical Calorimeter: two components ...

Electromagnetic (EM) +
Hadronic section (Had) ...

Different setups chosen for
optimal energy resolution ...

But:

Hadronic energy measured in
both parts of calorimeter ...

Needs careful consideration of
different response ...

Schematic of a
typical HEP calorimeter

Electrons
Photons

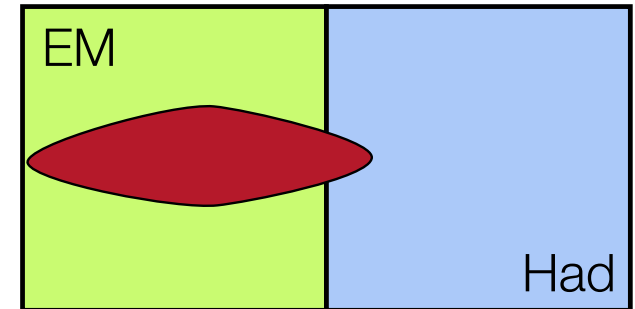

Taus
Hadrons

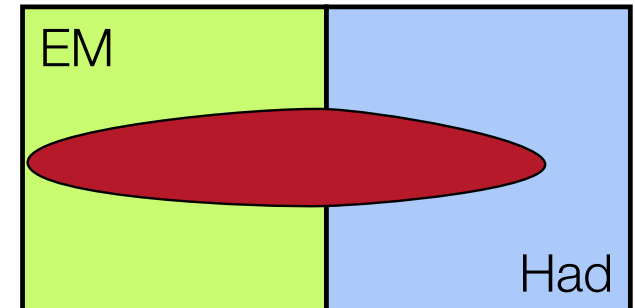

Jets

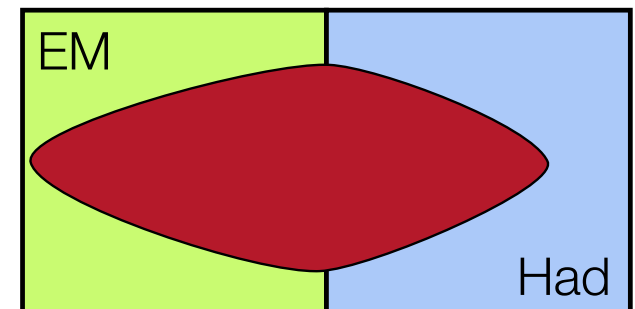

How do we “see” particles?

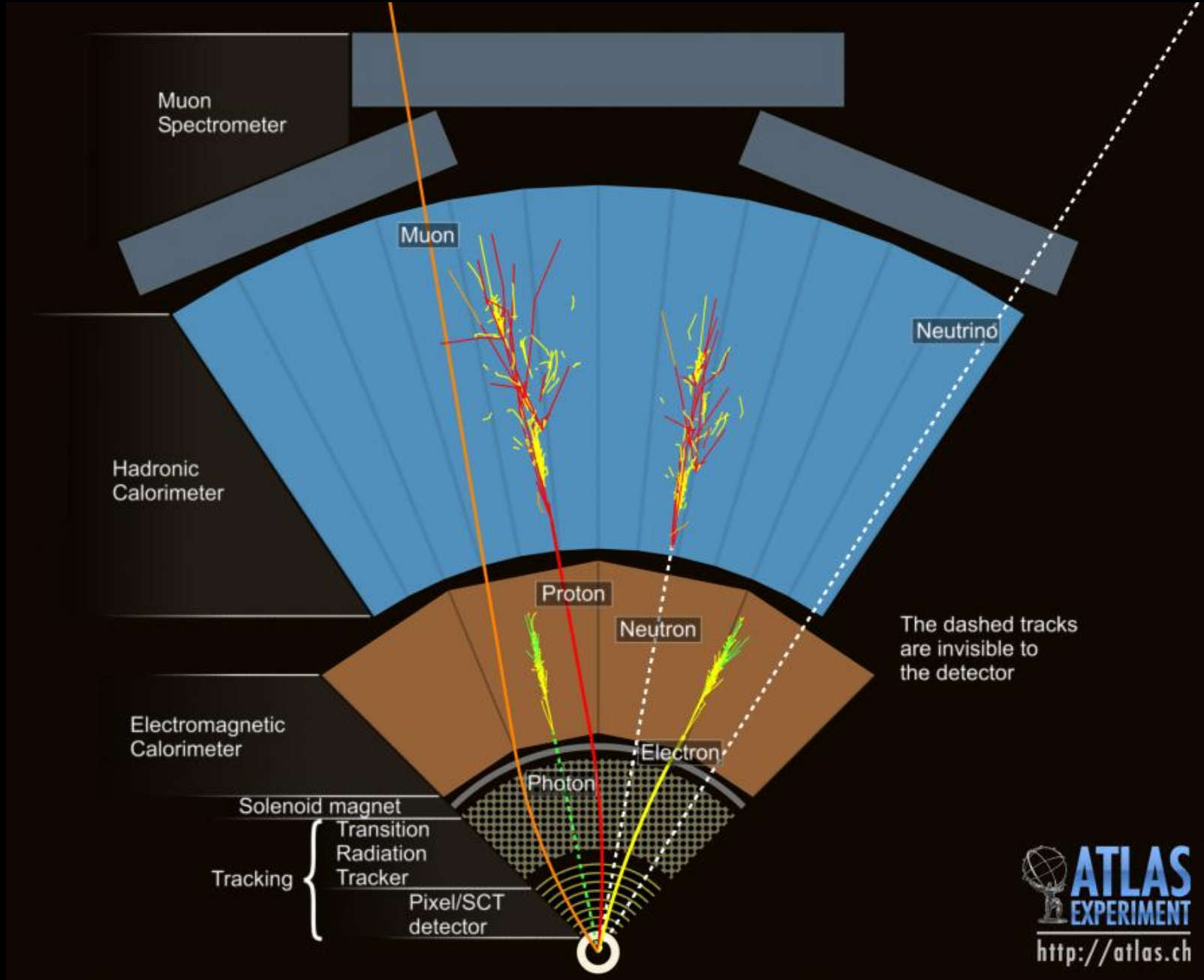

A few words on QCD

- QCD (strong) interactions are carried out by massless spin-1 particles called gluons

- ✓ Gluons are massless
 - Long range interaction
- ✓ Gluons couple to color charges
- ✓ Gluons have color themselves
 - They can couple to other gluons

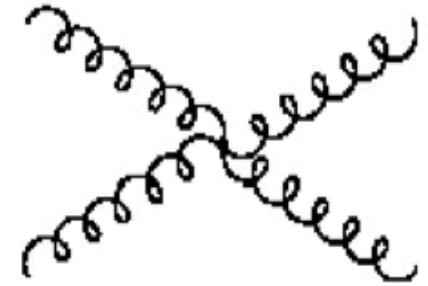
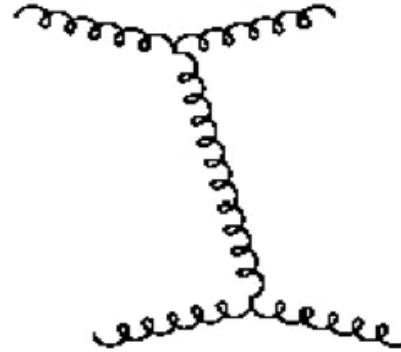

- **Principle of asymptotic freedom**

- ✓ At short distances strong interactions are weak
 - Quarks and gluons are essentially free particles
 - Perturbative regime (can calculate!)
- ✓ At large distances, higher-order diagrams dominate
 - Interaction is very strong
 - Perturbative regime fails, have to resort to effective models

quark-quark effective potential

$$V_s = -\frac{4}{3} \frac{\alpha_s}{r} + kr$$

$\underbrace{\hspace{10em}}$ $\underbrace{\hspace{5em}}$
single gluon exchange confinement

Confinement, hadronization, jets

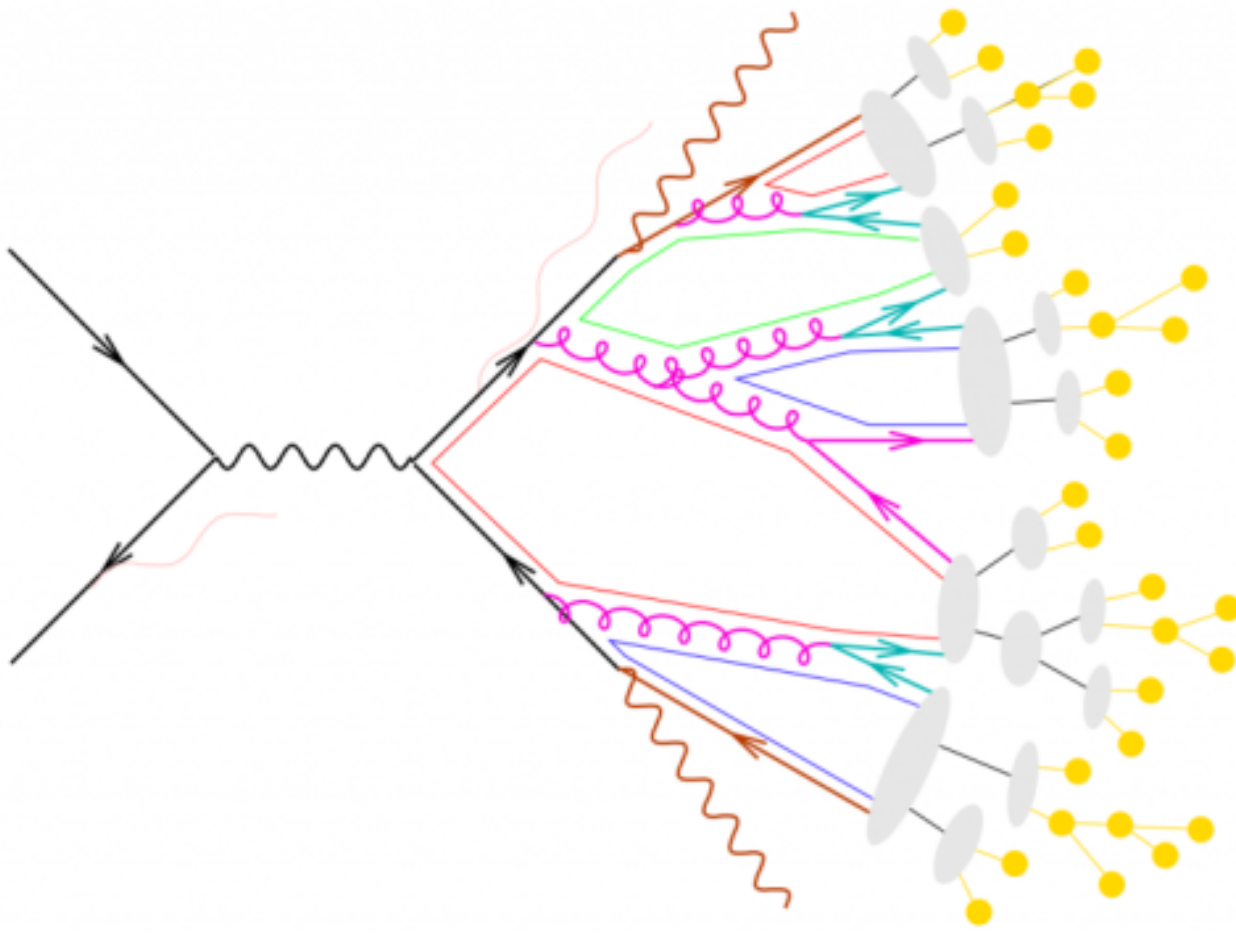
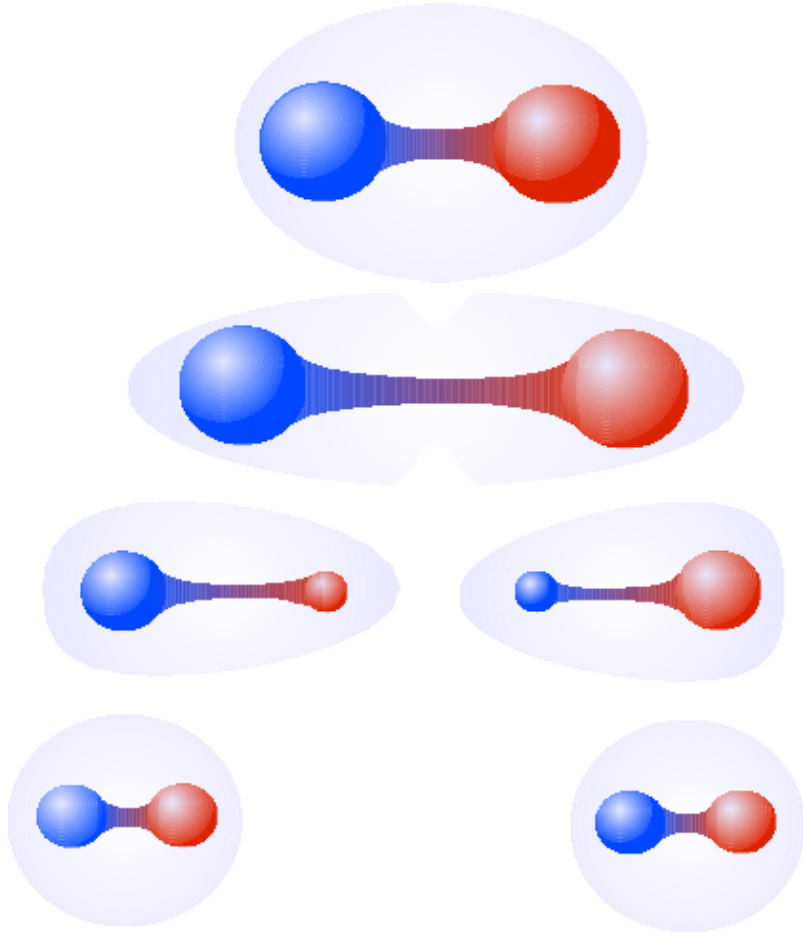

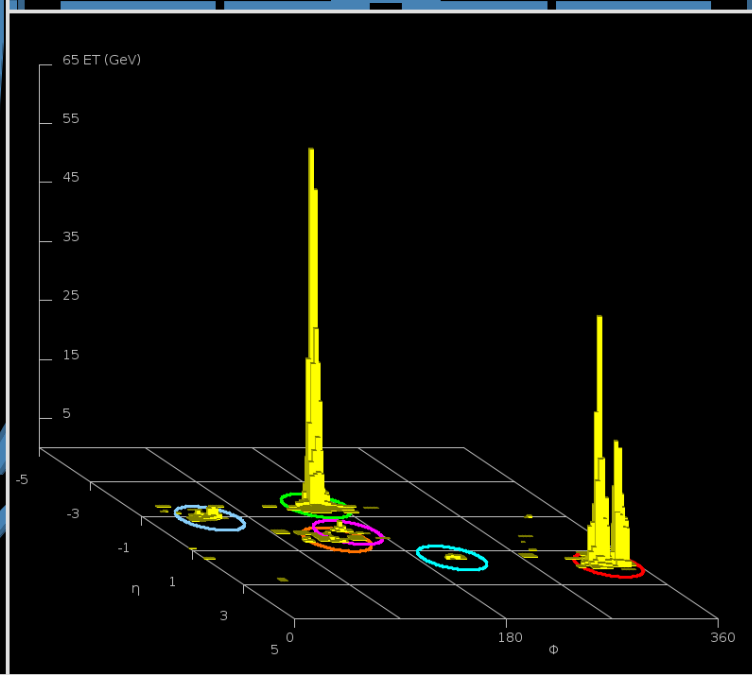
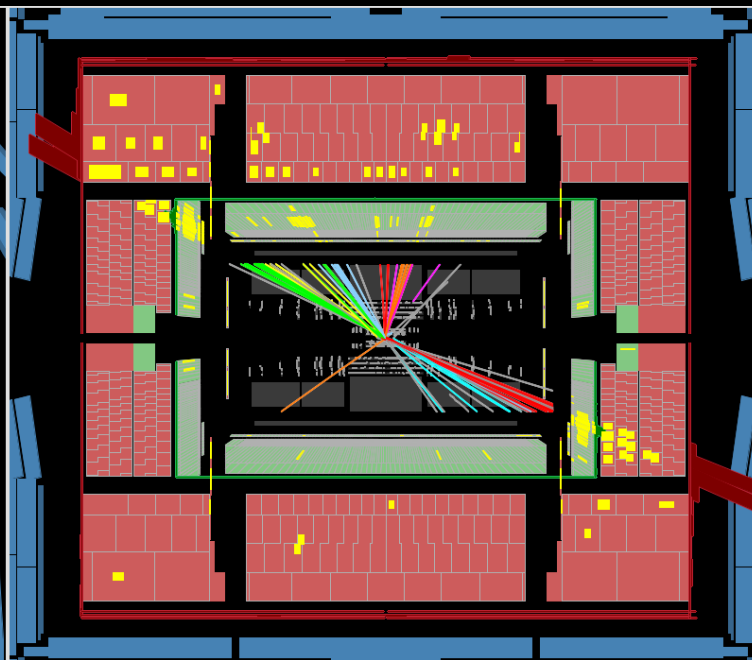
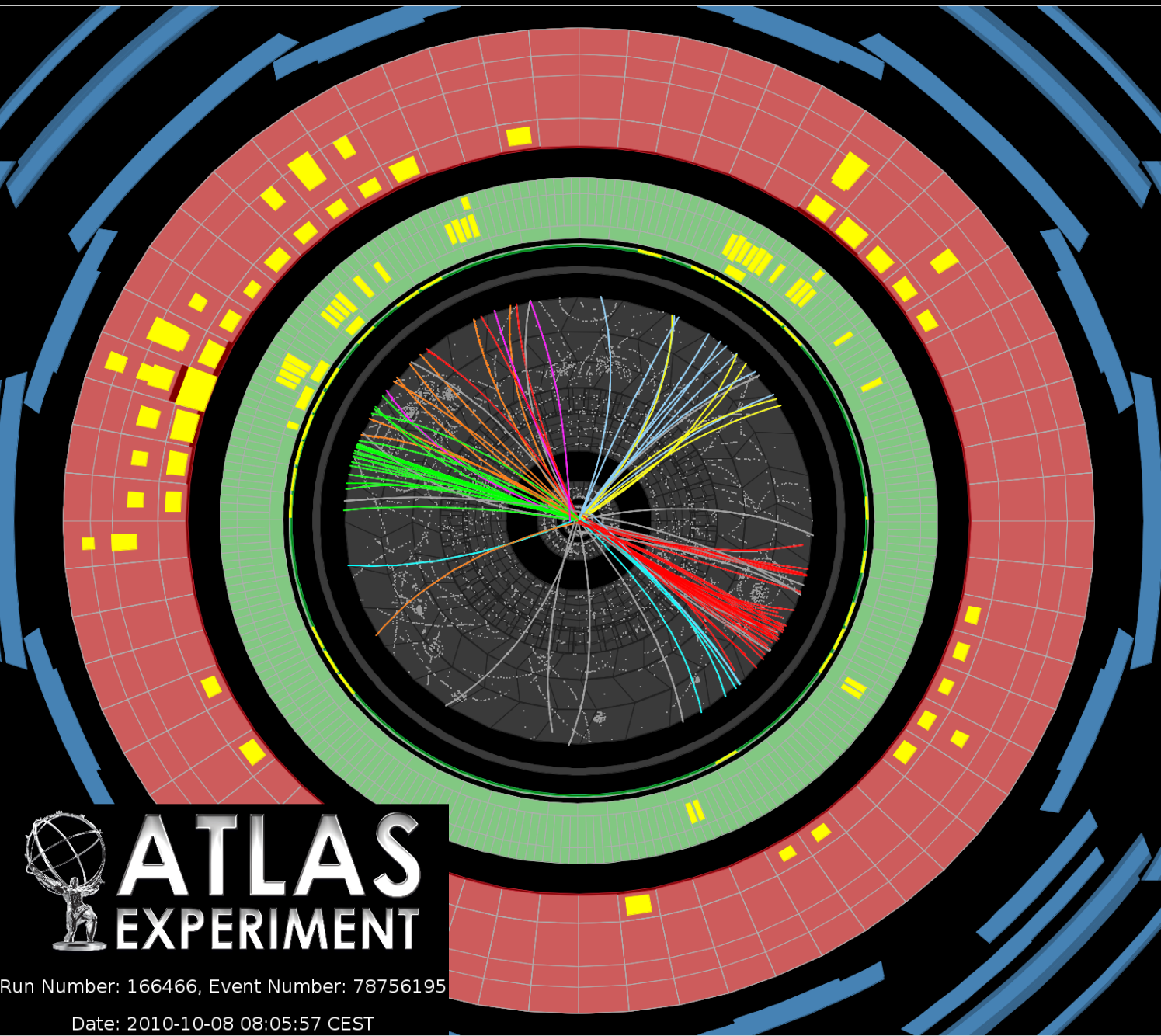

B-tagging



- When a b quark is produced, the associated jet will very likely contain at least one B meson or hadron
- B mesons/hadrons have relatively long lifetime
 - ✓ They will travel away from collision point before decaying
- Identifying a secondary decay vertex in a jet allow to tag its quark content
- Similar procedure for c quark...

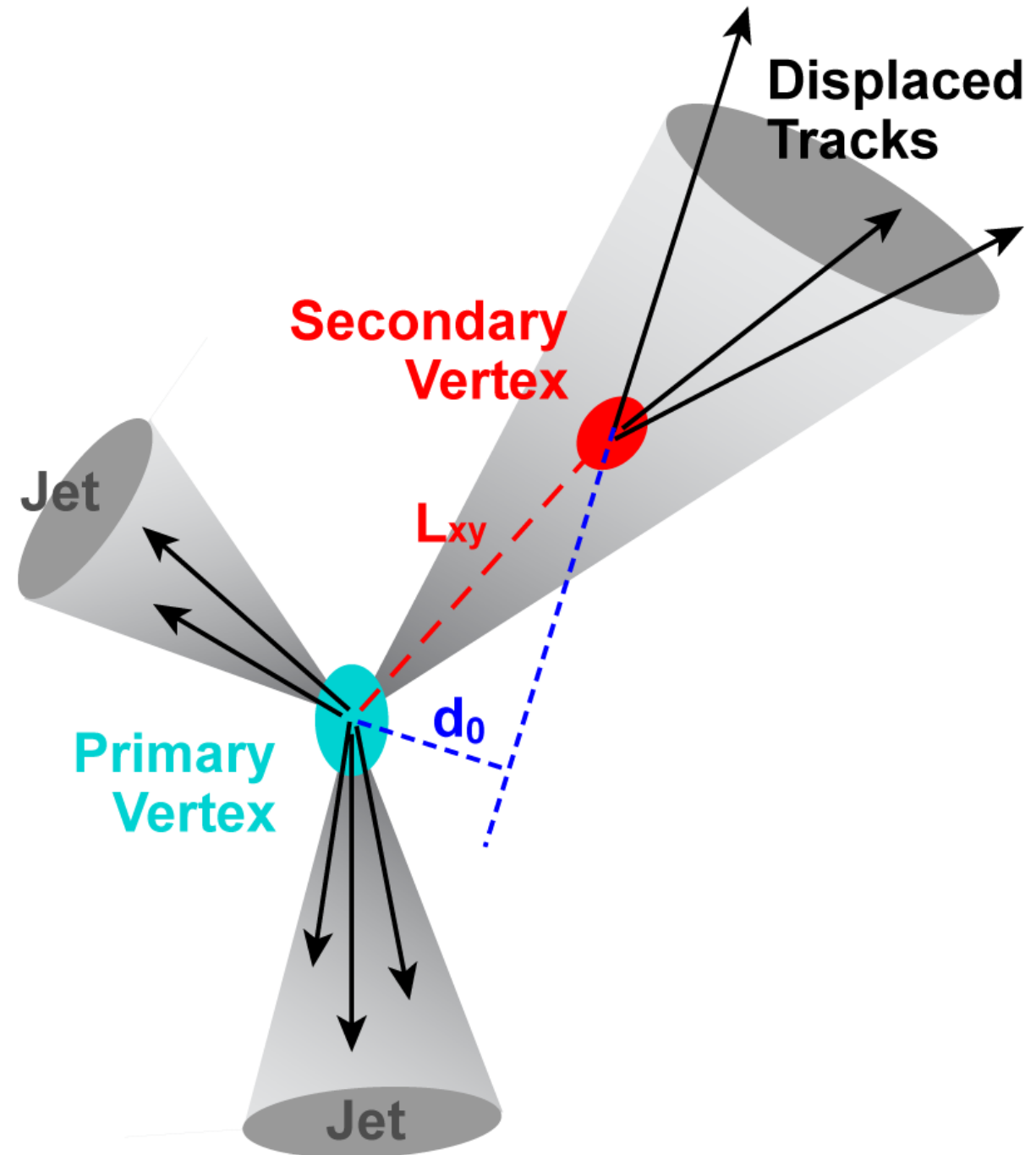

top quark



- Top quark has a mean lifetime of 5×10^{-25} s, shorter than time scale at which QCD acts: not time to hadronize!
 - ✓ It decays as $t \rightarrow Wb$
- Events with top quarks are very rich in (b) jets...

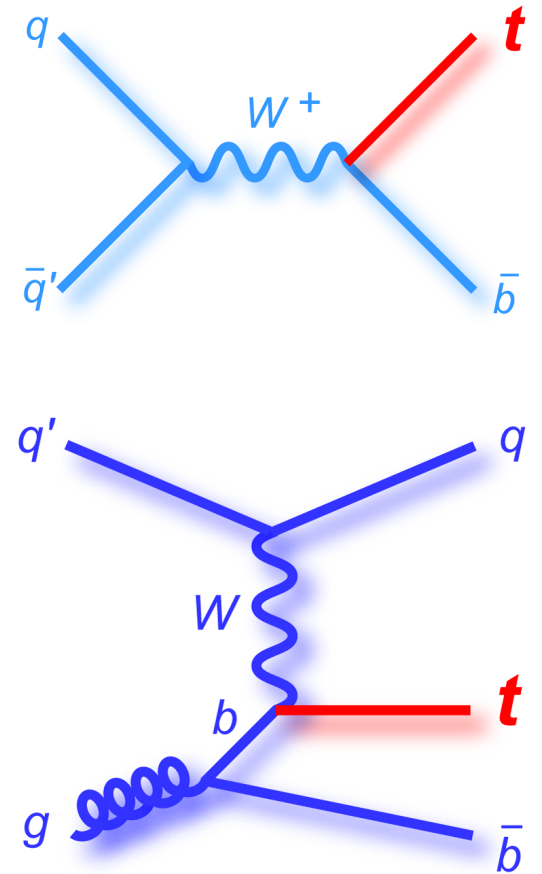
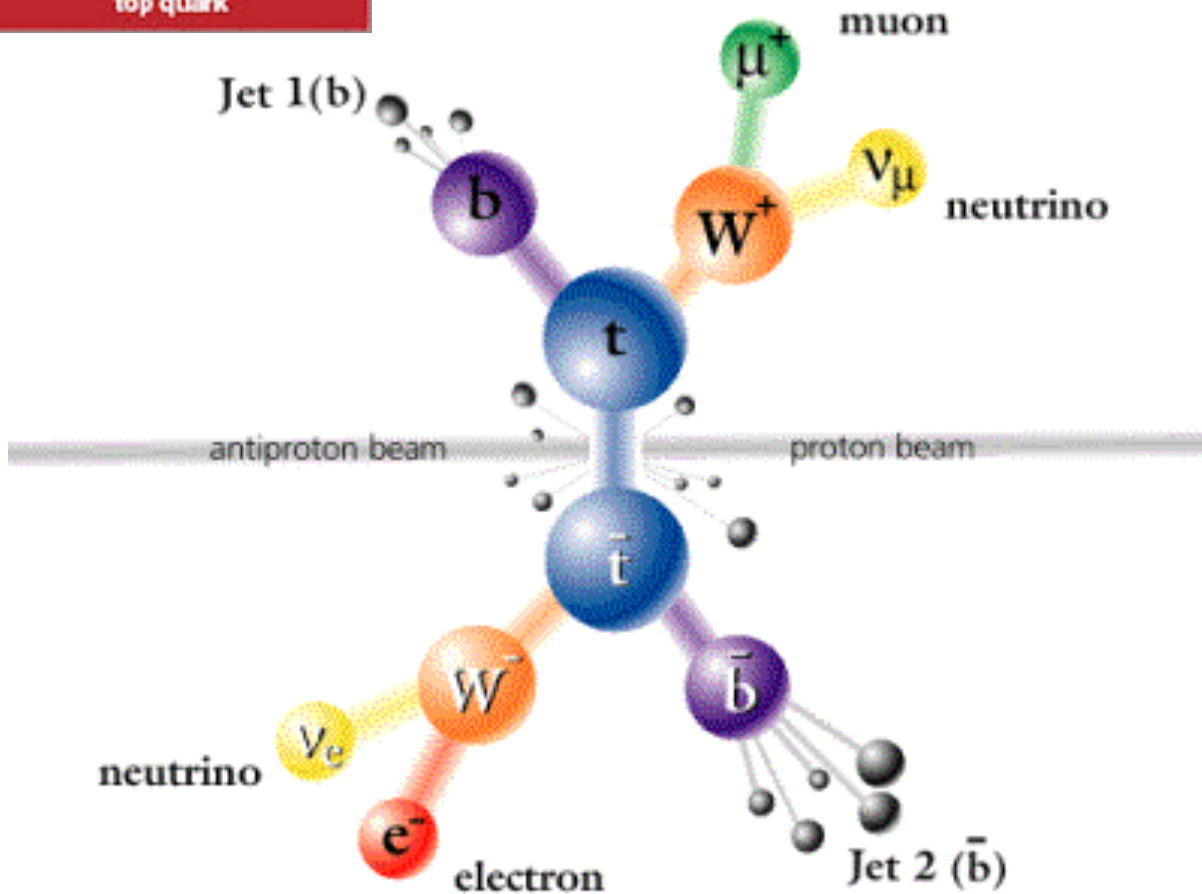

Boosted jets and jet substructure

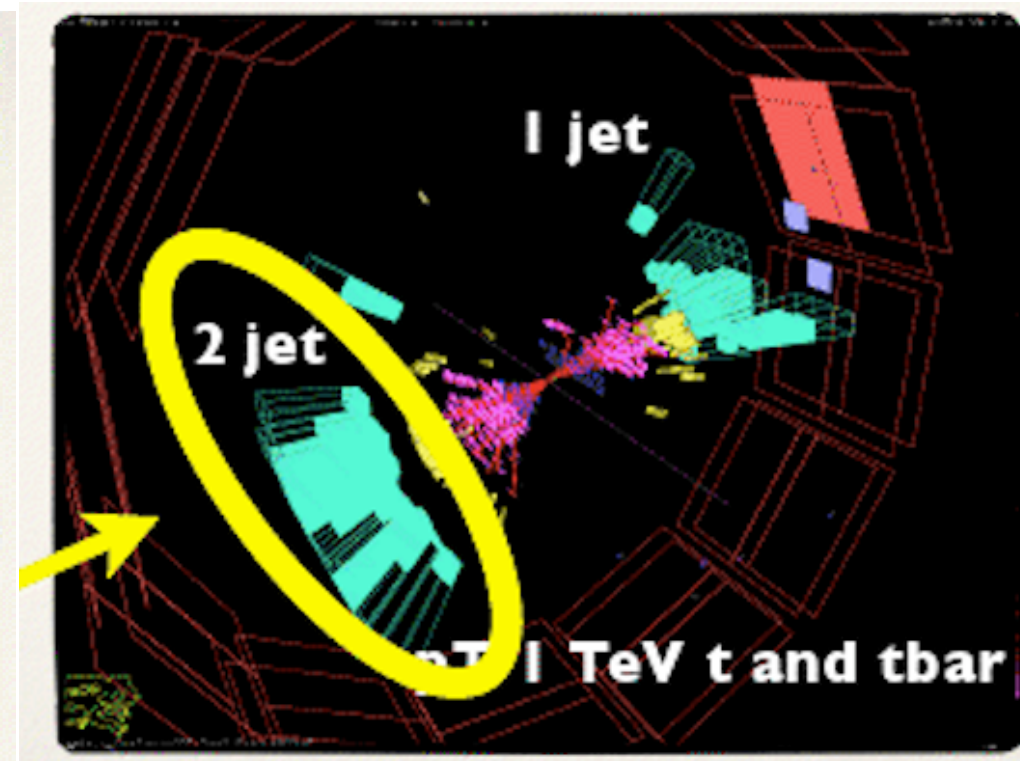
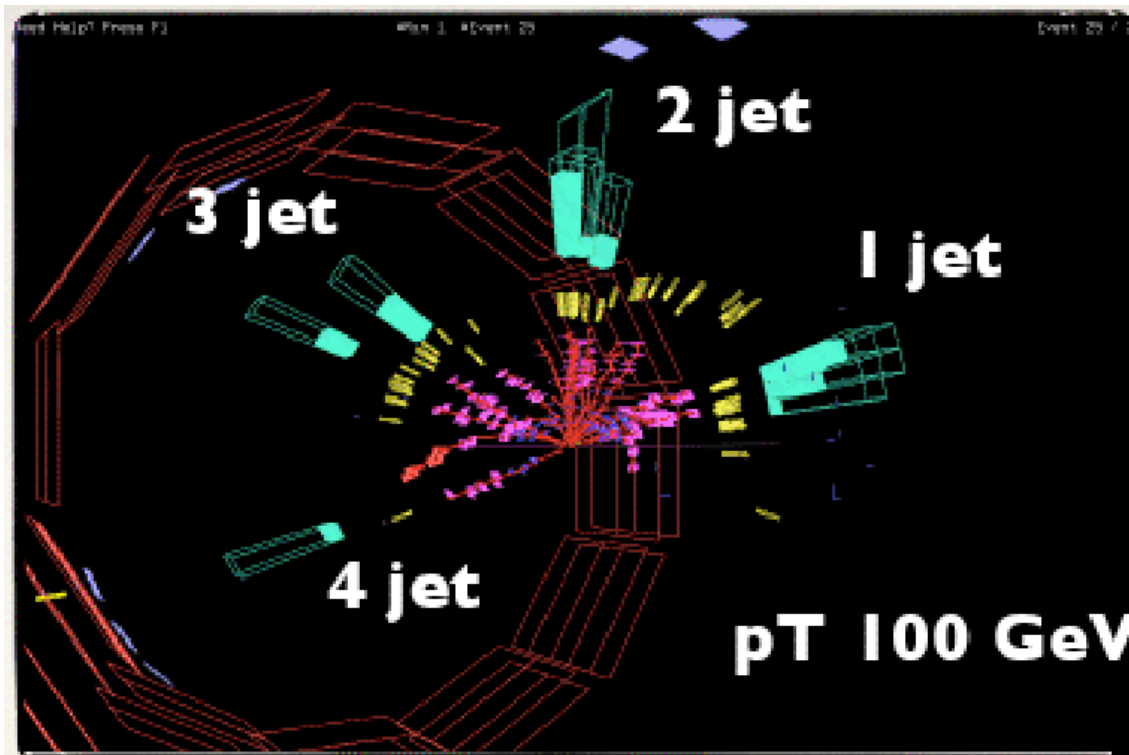
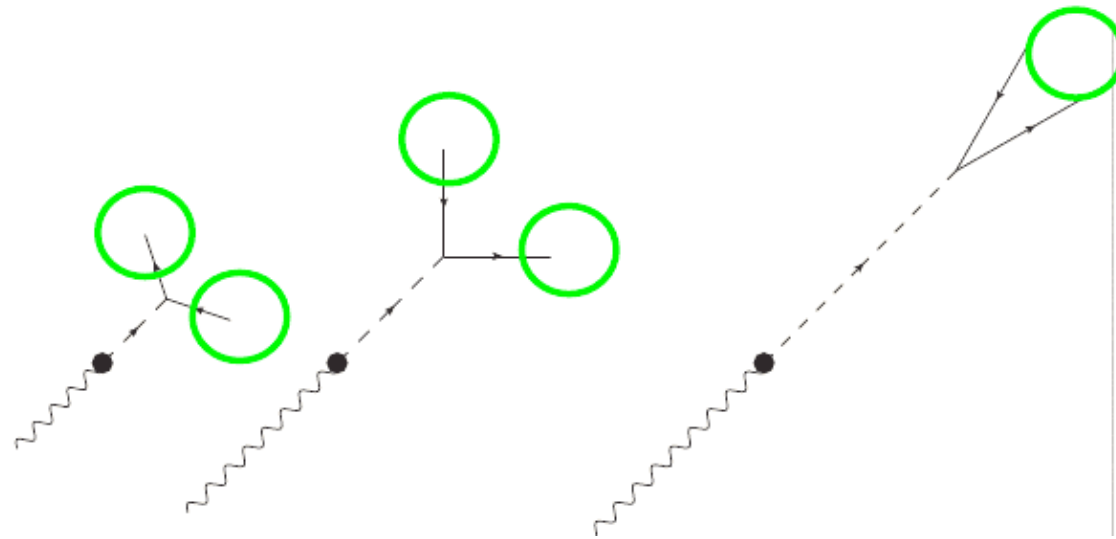

Tau



- Tau are heavy enough that they can decay in several final states
 - ✓ Several of them with hadrons
 - ✓ Sometimes neutral hadrons
- Lifetime = 0.29 ps
 - ✓ 10 GeV tau flies ~ 0.5 mm
 - ✓ Typically too short to be directly seen in the detectors
- Tau needs to be identified by their decay products
- Accurate vertex detectors can detect that they do not come exactly from the interaction point

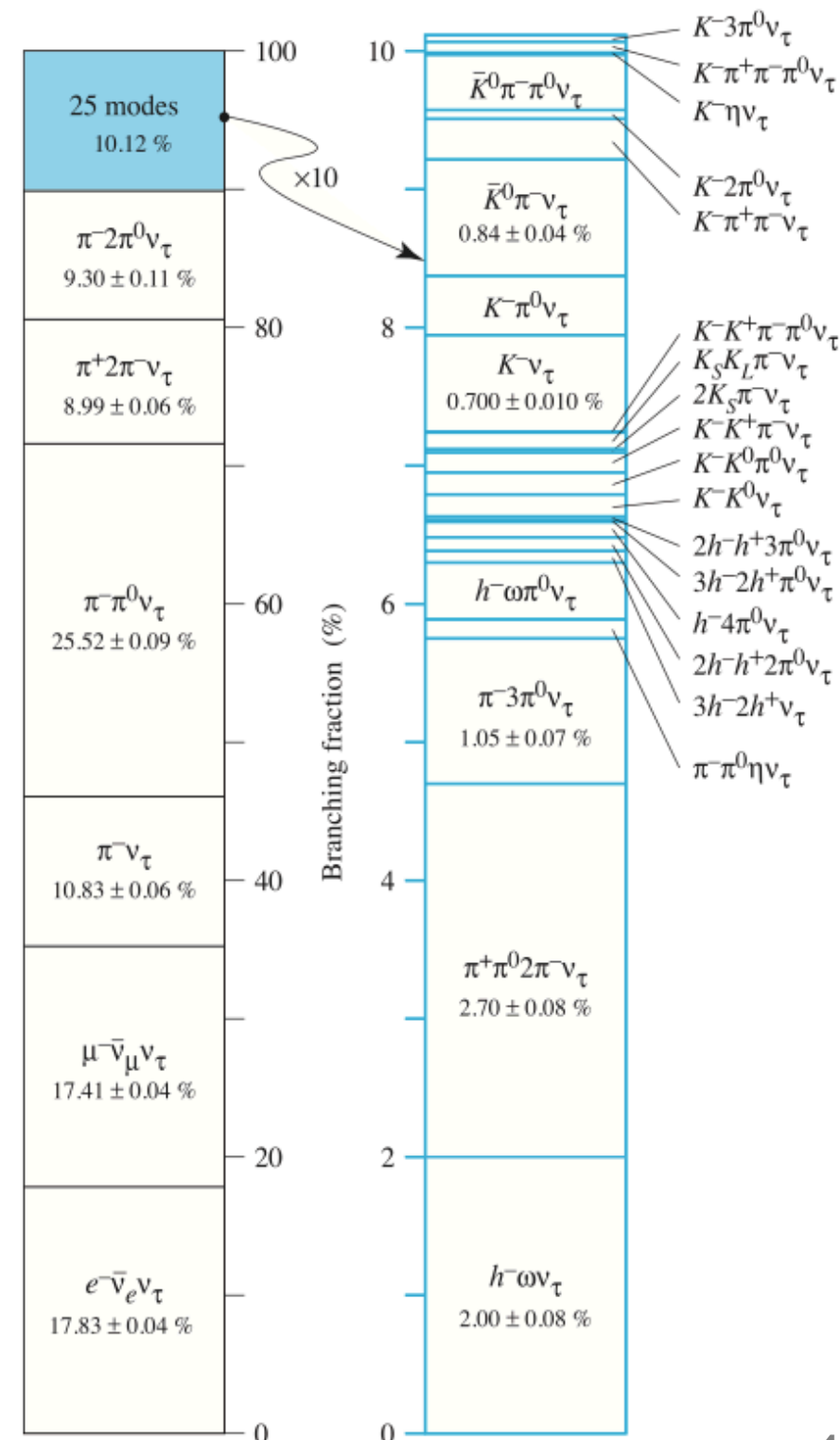

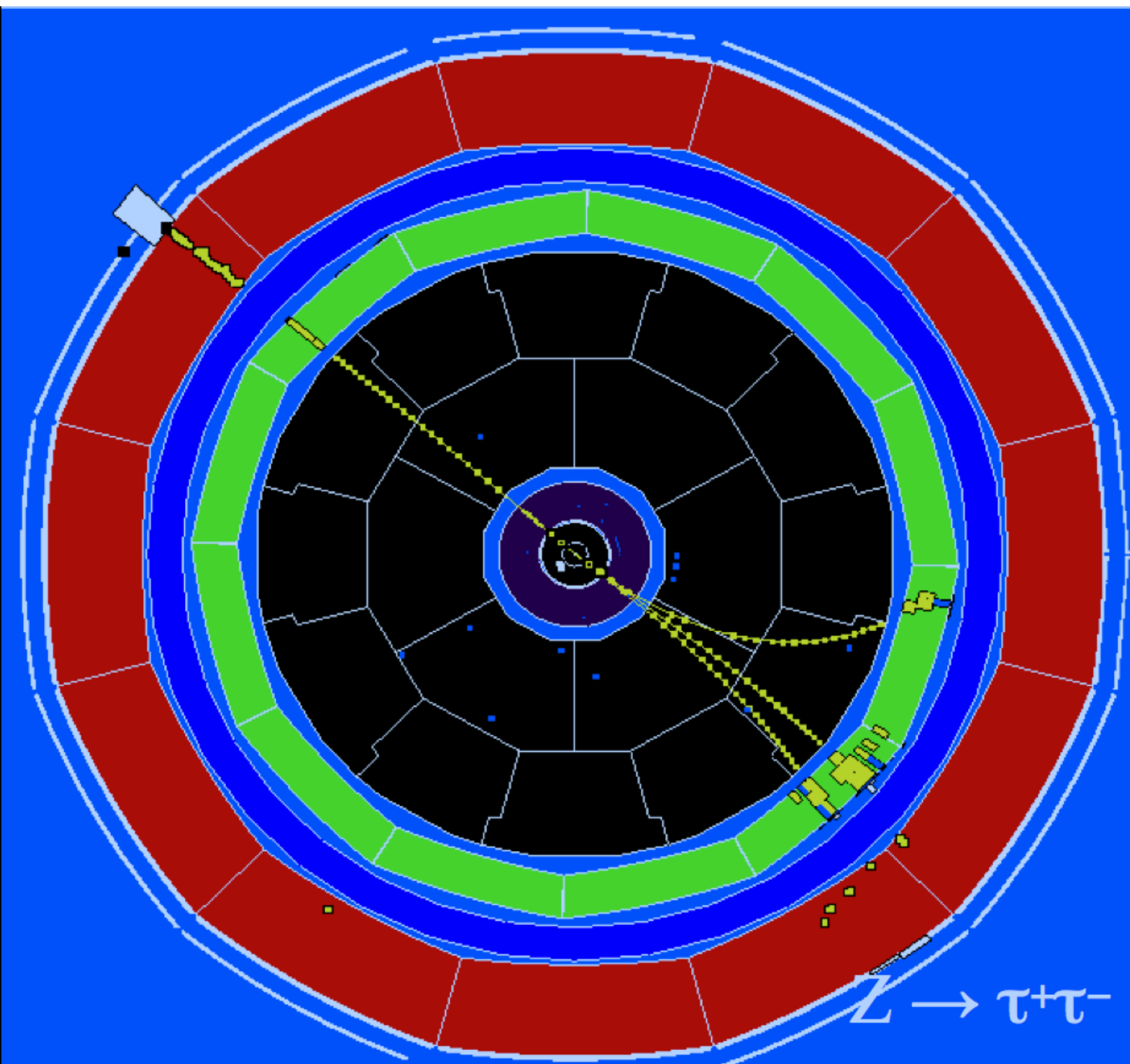

Neutrino (and other invisible particles) at colliders



- Interaction length $\lambda_{\text{int}} = A / (\rho \sigma N_A)$
- Cross section $\sigma \sim 10^{-38} \text{ cm}^2 \times E [\text{GeV}]$
 - ✓ This means 10 GeV neutrino can pass through more than a million km of rock
- Neutrinos are usually detected in HEP experiments through *missing (transverse) energy*

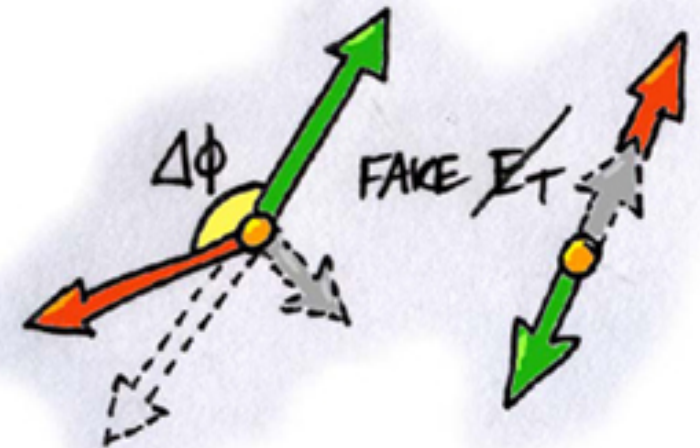
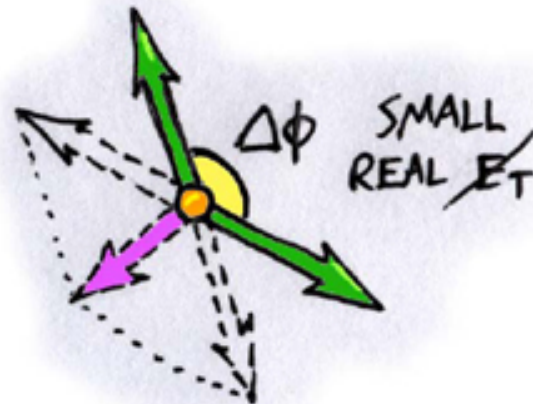
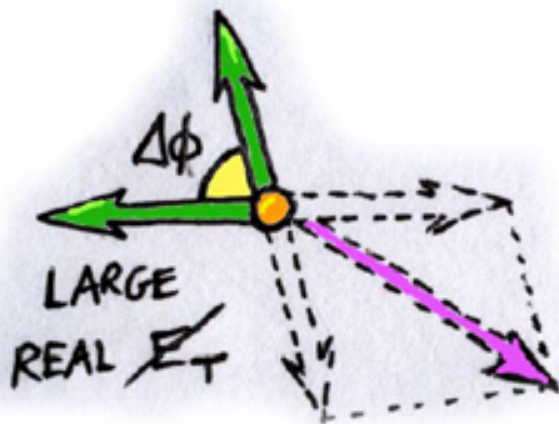

- Missing energy resolution depends on
 - ✓ Detector acceptance
 - ✓ Detector noise and resolution (e.g. calorimeters)