

Cooling

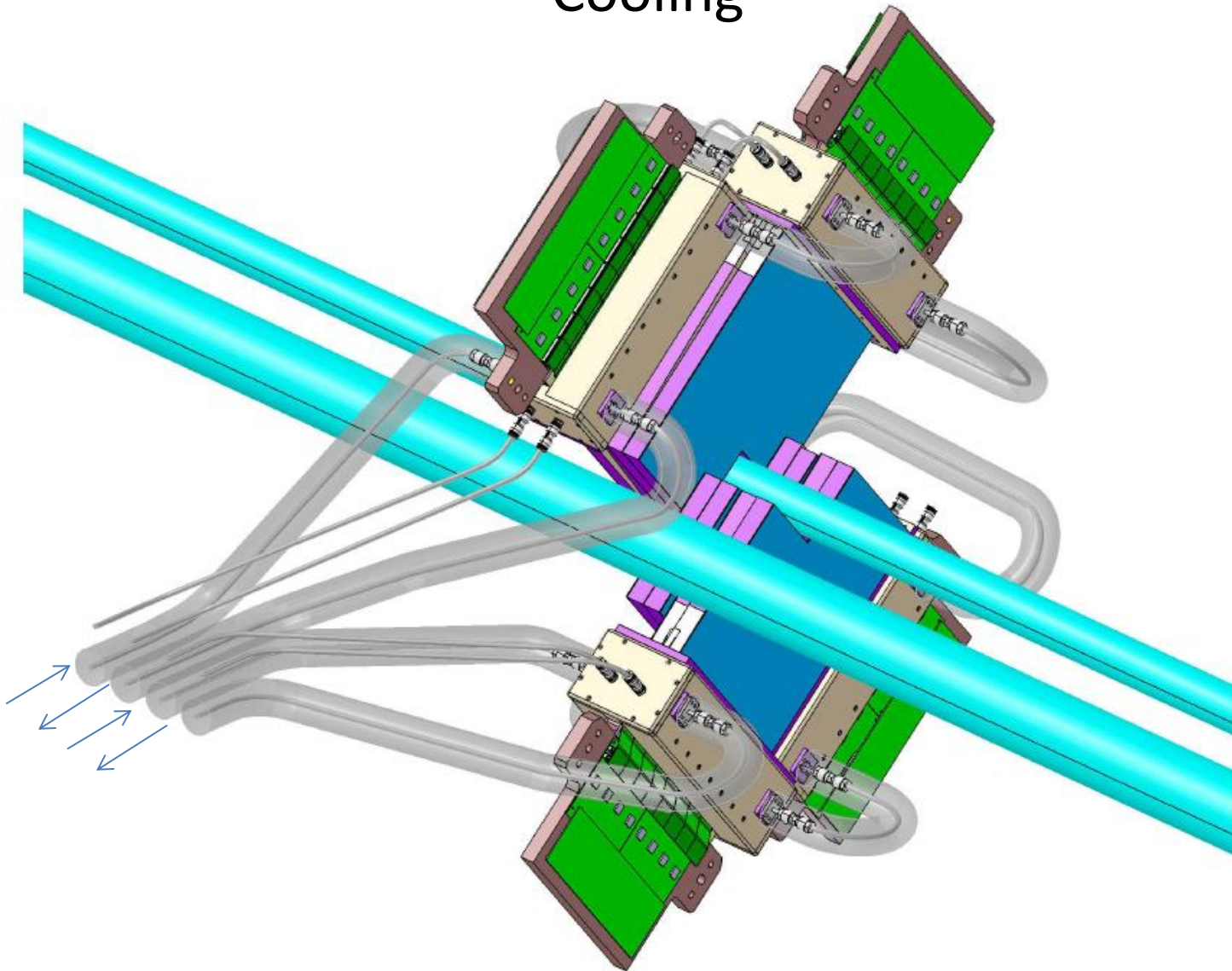

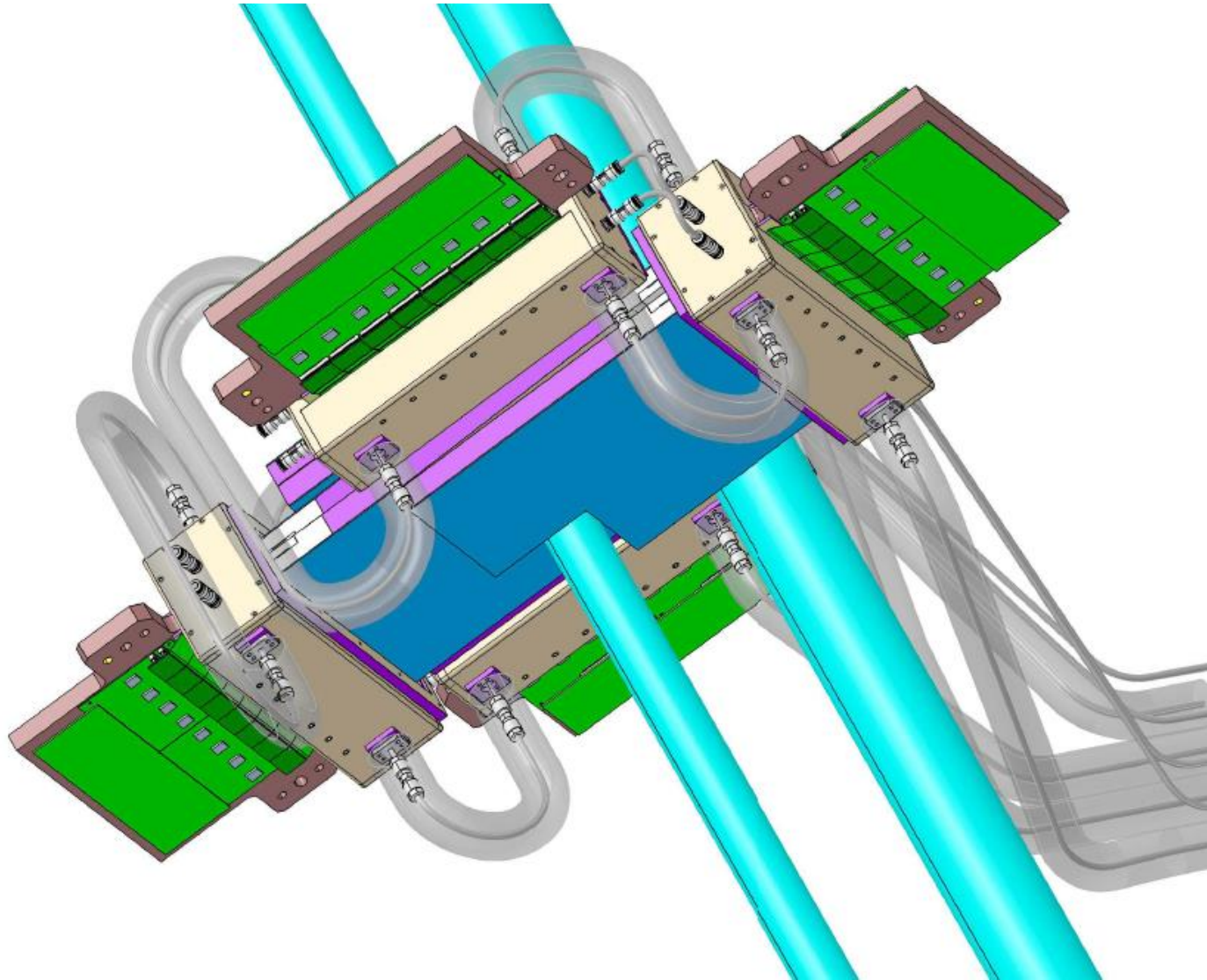

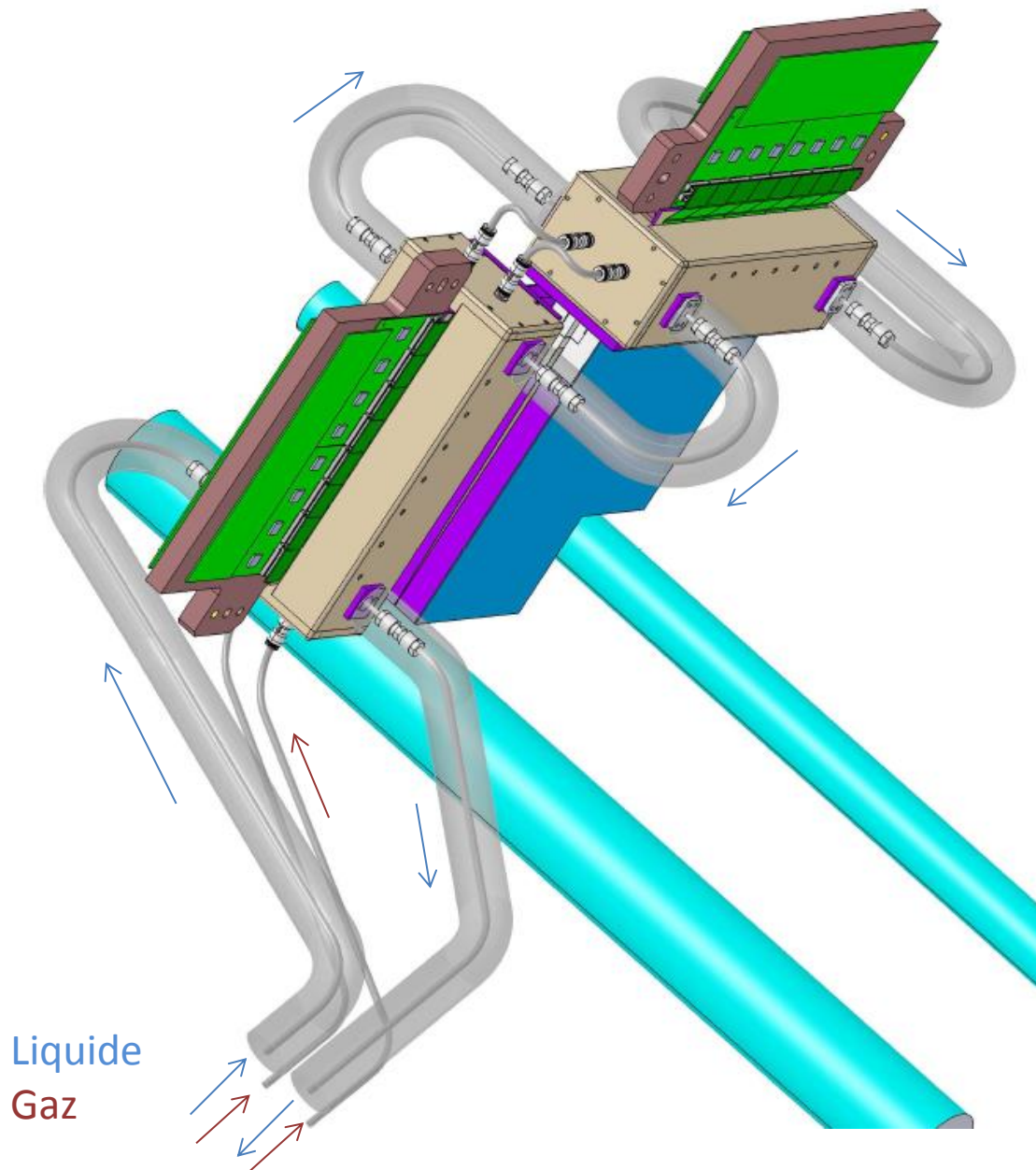

Serto

Polyurethan PU
Polyuréthane PU
Polyurethane PU

Øext 6mm
Øint 4mm



Raccord PVDF

Gerade Verschraubung
Union double
Straight union



Winkelverschraubung
Coude
Elbow union



Raccord Inox

Gerade Verschraubung
Union double
Straight union



SO 51021

AF/Armaflex



Dans la boîte
Øext (~42mm)
Øint 6mm

• Questions

- Cooling à l'intérieur de la boîte
 - Montage des tuyaux et raccordement
- Montage du cooling
- Quelle liquide sera utilisé
- Epaisseur isolation Armaflex
 - [http://www.armacell.ch/WWW/armacell/ACwwwAttach.nsf/ansFiles/AFArmaflexFF.pdf/\\$File/AFArmaflexFF.pdf](http://www.armacell.ch/WWW/armacell/ACwwwAttach.nsf/ansFiles/AFArmaflexFF.pdf/$File/AFArmaflexFF.pdf)
 - [http://www.armacell.ch/WWW/armacell/ACwwwAttach.nsf/ansFiles/TechnInfo3-FR.PDF/\\$File/TechnInfo3-FR.PDF](http://www.armacell.ch/WWW/armacell/ACwwwAttach.nsf/ansFiles/TechnInfo3-FR.PDF/$File/TechnInfo3-FR.PDF)
- Cooling à l'extérieur de la boîte
 - Longueur pour la ligne de cooling
 - Type de tuyau (nitrile avec raccord à sertir)
 - Isolation Armaflex
- «contrôle du débit»
- Fixation des tuyaux sur la structure



