

A Short Introduction to Heavy-Ion Physics

Sourendu Gupta

TIFR, Mumbai

8–9 November 2014

AEPSHEP

Puri, India

Why study heavy-ion collisions

- The largest context

- The phase diagram of QCD

- Summary

Observables

- General conditions in heavy-ion collisions

- Hard probes

- Probes of early thermalization

- Chemical composition of the final state

- Event by event fluctuations

- Summary

Some history and future plans

Outline

Why study heavy-ion collisions

The largest context

The phase diagram of QCD

Summary

Observables

General conditions in heavy-ion collisions

Hard probes

Probes of early thermalization

Chemical composition of the final state

Event by event fluctuations

Summary

Some history and future plans

Outline

Why study heavy-ion collisions

The largest context

The phase diagram of QCD

Summary

Observables

General conditions in heavy-ion collisions

Hard probes

Probes of early thermalization

Chemical composition of the final state

Event by event fluctuations

Summary

Some history and future plans

The early universe

Physics of the early universe involves particles at finite temperature. Can we approximate it as an ideal gas of particles?

No: there are particle reactions, freezeout, and (maybe) phase transitions. Ideal gases have none of these. Interactions are important: quantum field theory at finite temperature is needed. How to test FT-QFT in the lab?

Need to produce thermalized matter in particle colliders. Initial states of leptons produce energy densities less than $1/\text{fm}^4$. Mean free paths are significantly larger than fm, so this does not thermalize. Initial states of hadrons produce energy densities of about $1\text{--}10/\text{fm}^4$, mean free paths are about fm, so may thermalize. Increase volume by taking heavy ions: easier to produce thermalized matter.

Phase transitions

QFTs contain many symmetries:

1. Exact gauge symmetries
2. Higgsed gauge symmetries
3. Global flavour symmetries
4. Global chiral symmetries

Any of these can be broken or restored at finite temperature. For every global symmetry there can be chemical potentials; large and interesting phase diagrams.

Since colliders may create thermalized strongly interacting matter, phase diagram of QCD is being mapped out. Tools of the trade: effective field theories, lattice gauge theory.

Outline

Why study heavy-ion collisions

The largest context

The phase diagram of QCD

Summary

Observables

General conditions in heavy-ion collisions

Hard probes

Probes of early thermalization

Chemical composition of the final state

Event by event fluctuations

Summary

Some history and future plans

How many flavours

- ▶ When quarks are massless, chiral symmetry, *i.e.*, independent flavour transformations of the two chiralities. Chiral symmetry broken by the Goldstone mechanism: massless pions and a quark condensate. Symmetry restored at a temperature T_c .
- ▶ Remaining flavour symmetries not exact: difference in quark masses breaks flavour symmetry. When $m_u \neq m_d$, isospin symmetry broken. When flavour symmetry completely broken, then independent chemical potential, μ , for each flavour.
- ▶ Since $m_{\pi^0} \simeq m_{\pi^\pm}$, flavour SU(2) is a good approximate symmetry of the hadron world. Flavour SU(3) is not useful without symmetry breaking terms (Gell-Mann and Nishijima).
- ▶ If some $m \gg \Lambda_{QCD}$ then that quark is not approximately chiral. In QCD two flavours are light ($m_{u,d} \ll \Lambda_{QCD}$) and one is medium heavy ($m_s \simeq \Lambda_{QCD}$). Recall that $m_\pi = 0.2m_\rho$ but $m_K = 0.7m_\rho$.

The two flavour world

- ▶ What distinguishes the phases? Exact answer only for massless quarks. In the vacuum chiral symmetry is broken; $\langle \bar{\psi}\psi \rangle$ **chiral condensate** is non-vanishing. Pions are the massless fluctuations around the vacuum. At high temperature $\langle \bar{\psi}\psi \rangle = 0$.
- ▶ When correlation lengths finite then susceptibility always finite:

$$\chi = \int d^3x C(x), \quad C(x) \simeq \exp(-mx), \quad \xi = 1/m_\pi.$$

At critical points correlation lengths diverge; integral diverges, so susceptibility diverges.

- ▶ When quarks are massive, then at transition scalar mass degenerate with $m_\pi \neq 0$. No vanishing masses, so all susceptibilities finite. May still have a maximum as T changes: cross over for massive quarks.

The two flavour phase diagram

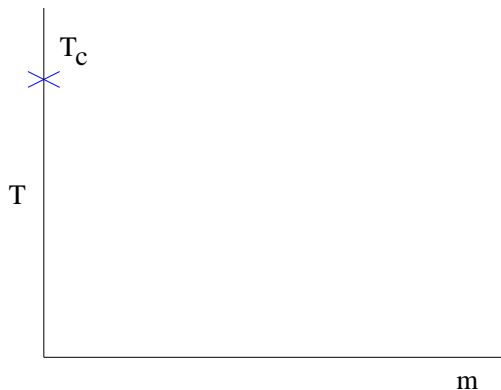

Pisarski, Wilczek, 1980s; Rajagopal, Stephanov, Shuryak hep-ph/9806219 and hep-ph/9903292

The two flavour phase diagram

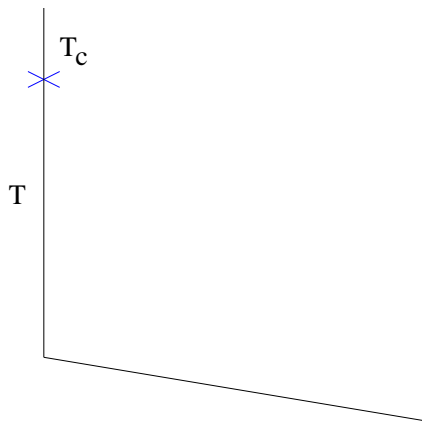

Pisarski, Wilczek, 1980s; Rajagopal, Stephanov, Shuryak hep-ph/9806219 and hep-ph/9903292

The two flavour phase diagram

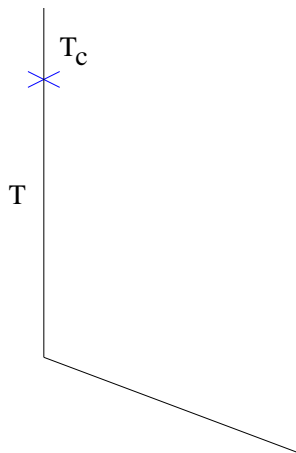

Pisarski, Wilczek, 1980s; Rajagopal, Stephanov, Shuryak hep-ph/9806219 and hep-ph/9903292

The two flavour phase diagram

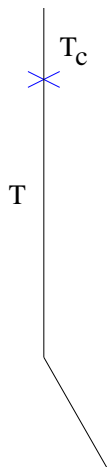

Pisarski, Wilczek, 1980s; Rajagopal, Stephanov, Shuryak hep-ph/9806219 and hep-ph/9903292

The two flavour phase diagram

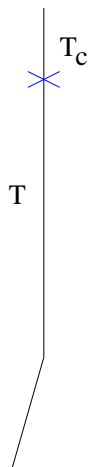

Pisarski, Wilczek, 1980s; Rajagopal, Stephanov, Shuryak hep-ph/9806219 and hep-ph/9903292

The two flavour phase diagram

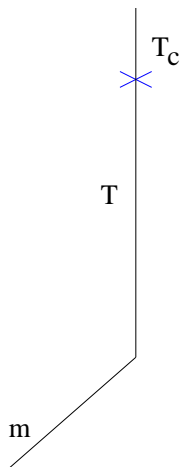

Pisarski, Wilczek, 1980s; Rajagopal, Stephanov, Shuryak hep-ph/9806219 and hep-ph/9903292

The two flavour phase diagram

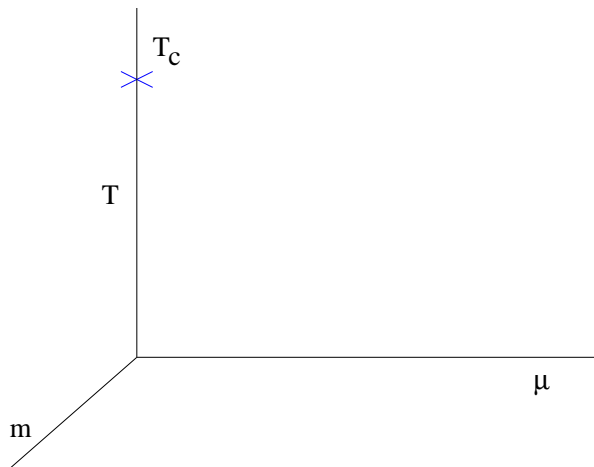

Pisarski, Wilczek, 1980s; Rajagopal, Stephanov, Shuryak hep-ph/9806219 and hep-ph/9903292

The two flavour phase diagram

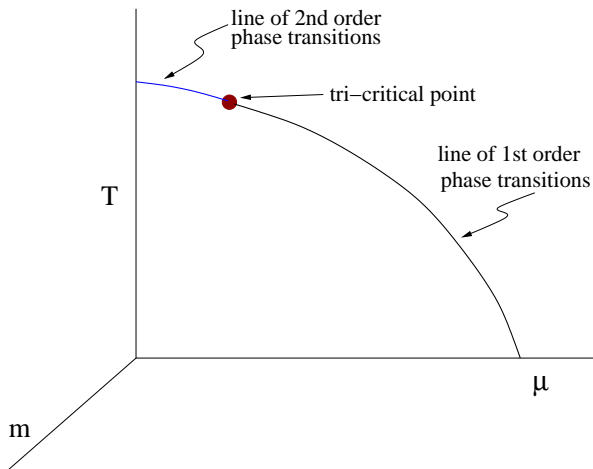

Pisarski, Wilczek, 1980s; Rajagopal, Stephanov, Shuryak hep-ph/9806219 and hep-ph/9903292

The two flavour phase diagram

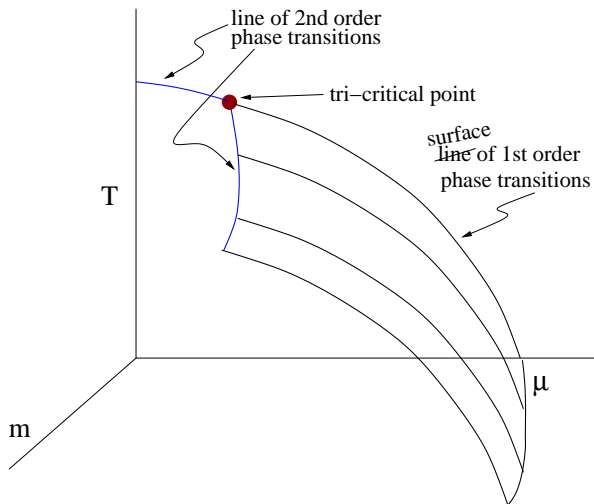

Pisarski, Wilczek, 1980s; Rajagopal, Stephanov, Shuryak hep-ph/9806219 and hep-ph/9903292

The two flavour phase diagram

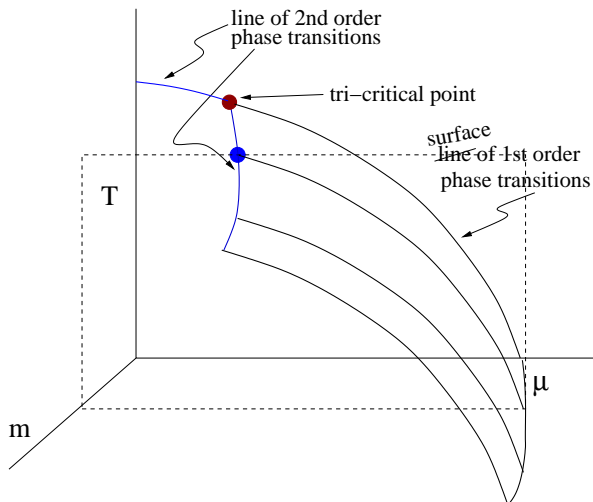

Pisarski, Wilczek, 1980s; Rajagopal, Stephanov, Shuryak hep-ph/9806219 and hep-ph/9903292

The two flavour phase diagram

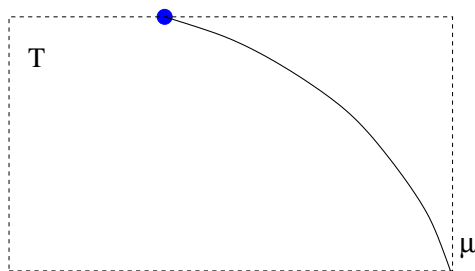

Pisarski, Wilczek, 1980s; Rajagopal, Stephanov, Shuryak hep-ph/9806219 and hep-ph/9903292

The two flavour phase diagram

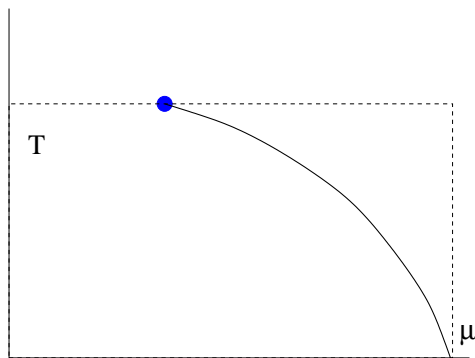

Pisarski, Wilczek, 1980s; Rajagopal, Stephanov, Shuryak hep-ph/9806219 and hep-ph/9903292

The two flavour phase diagram

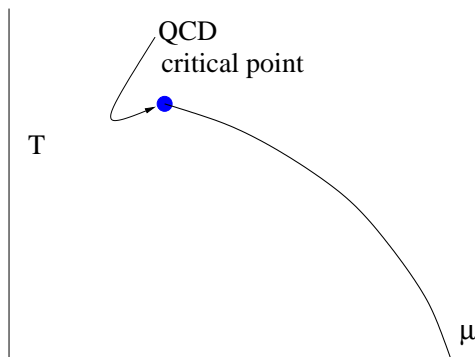

Pisarski, Wilczek, 1980s; Rajagopal, Stephanov, Shuryak hep-ph/9806219 and hep-ph/9903292

Lattice results for broken isospin

Only one study; $m_{\pi 0}/m_{\pi \pm}$ is changed from 1 to 0.78 (physical value bracketed).

$$\frac{T_c}{\Lambda_{\overline{MS}}} = \begin{cases} 0.49 \pm 0.02 & (m_{\pi 0}^2/m_{\pi \pm}^2 = 1) \\ 0.49 \pm 0.02 & (m_{\pi 0}^2/m_{\pi \pm}^2 = 0.78) \end{cases}$$

Both results extrapolated to the physical value of m_{π}/m_{ρ} .

Gvai, SG, hep-lat/0208019 (2002)

Caveats:

- ▶ lattice spacings are coarse by today's standards
- ▶ quark masses can be now be more realistic
- ▶ finite volume effects yet to be quantified.

How important is the strange quark?

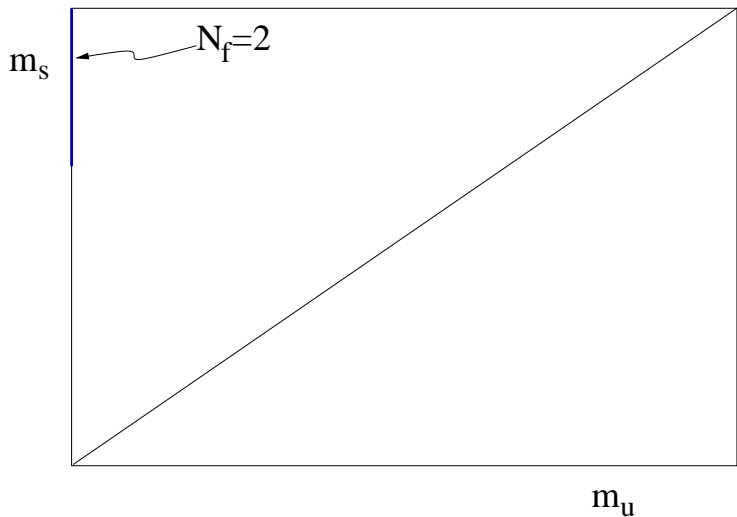

Columbia plot: Brown et al, PRL 65, 2491 (1990)

How important is the strange quark?

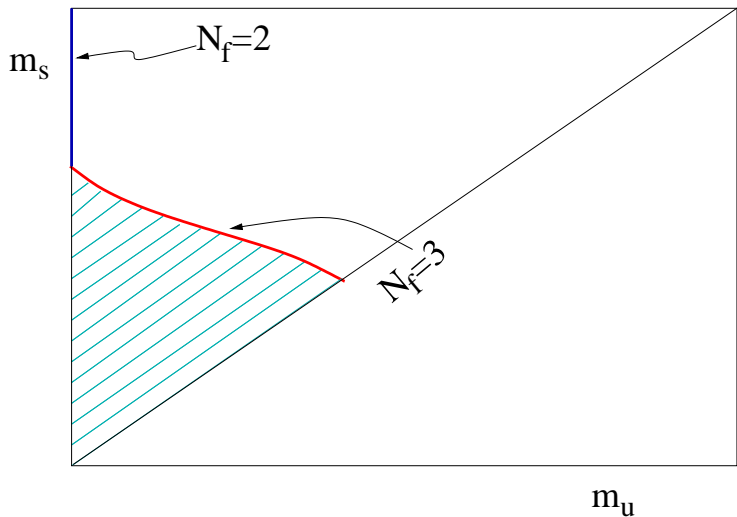

Columbia plot: Brown et al, PRL 65, 2491 (1990)

How important is the strange quark?

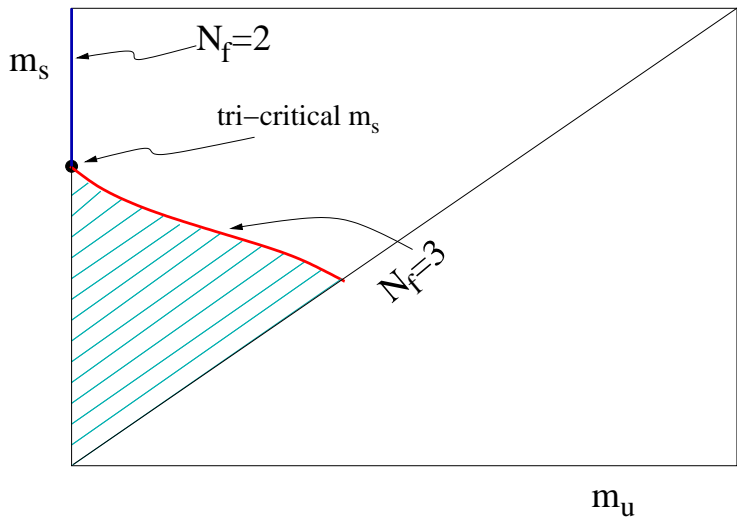

Columbia plot: Brown et al, PRL 65, 2491 (1990)

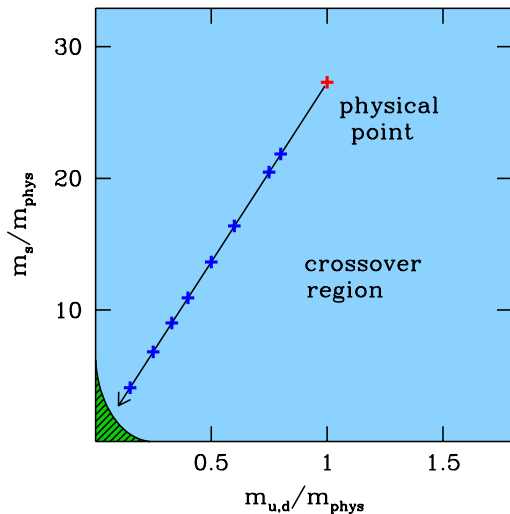
Lattice results for m_s^{3C} 

In $N_f = 2 + 1$:

$$m_{\pi}^{\text{crit}} \begin{cases} = 0.07m_{\pi} & (N_t = 4) \\ < 0.12m_{\pi} & (N_t = 6) \end{cases}$$

Endrodi et al,
0710.0988 (2007)

Similarly for $N_f = 3$.

Karsch et al, hep-
lat/0309121 (2004)

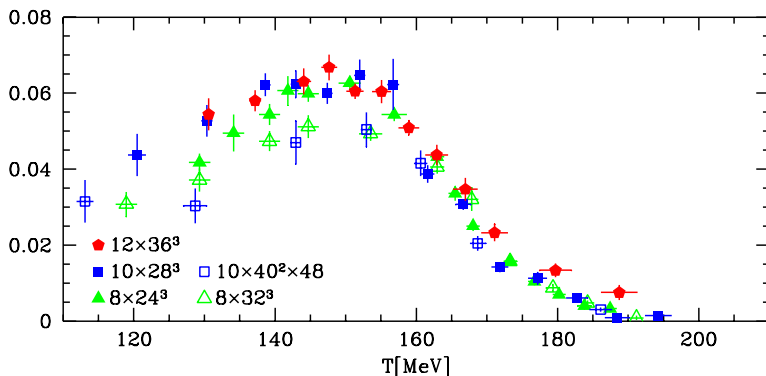
Crossover at realistic m_π 

Broad crossover: figure shows chiral susceptibility; Even with one measure, T_c uncertain by 20 MeV.

Aoki et al, 0903.4155

Values of T_c in QCD

Chiral susceptibility	χ_m/T^4	$146 \pm 2 \pm 3$ MeV
	χ_m/T^2	$152 \pm 3 \pm 3$ MeV
	χ_m	$157 \pm 3 \pm 3$ MeV
Chiral condensate	Δ_{ls}	$155 \pm 2 \pm 3$ MeV
Polyakov loop		$170 \pm 4 \pm 3$ MeV
Strangeness susceptibility	χ_s	$169 \pm 3 \pm 3$ MeV

Aoki et al, 0903.4155

When to use an index

Because of the complexity of the underlying concept, an index might be particularly unhelpful or meaningless.

—Arvind Subramaniam, Chief Economic Advisor to the PM.

If a definition is arbitrary, then arbitrarily choose a definition, but insist that physics be independent of it.

The critical point of QCD

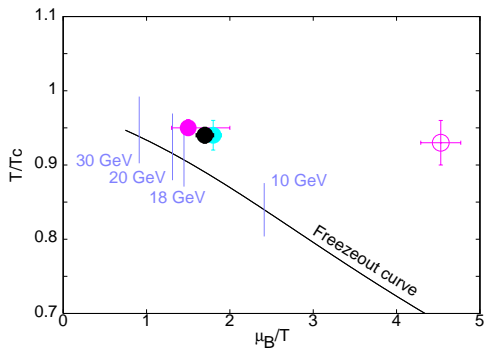

Budapest: 2001; ILGTI: 2005, 2007, 2011, 2014

The critical point of QCD

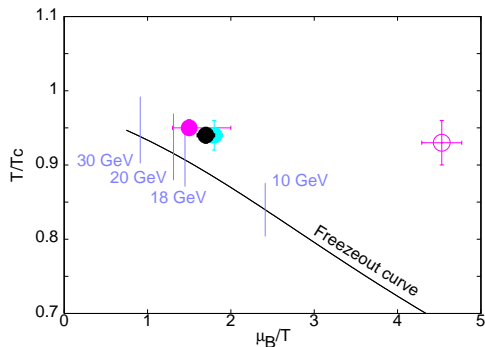

Budapest: 2001; ILGTI: 2005, 2007, 2011, 2014

$$\frac{\mu^E}{T^E} \simeq \begin{cases} 1.5 \pm 0.3 & N_f = 2, \text{ ILGTI, 1405.2206 (2014)} \\ 1.5 \pm 0.4 & N_f = 2 + 1, \text{ BNL-Bielefeld, unpublished, 2010} \end{cases}$$

comparable a , m_π ; normalized to same estimator.

Outline

Why study heavy-ion collisions

The largest context

The phase diagram of QCD

Summary

Observables

General conditions in heavy-ion collisions

Hard probes

Probes of early thermalization

Chemical composition of the final state

Event by event fluctuations

Summary

Some history and future plans

Summary

1. Chiral QCD has a chirality restoring phase transition at finite T . Such a transition persists even in the presence of fairly light, but non-zero mass, strange quarks. Much heavier quarks have effect on this phase transition.
2. At finite light quark masses, there is no phase transition at $\mu = 0$. The chiral transition becomes a cross over. The cross over temperature, T_c , depends on the definition and can vary between 170 MeV and 145 MeV. There is little effect of isospin symmetry breaking on the cross over. LHC operates in the regime where μ is extremely small, and therefore explores baryonless thermal QCD.
3. Even when the light quark masses are finite, there is a genuine phase transition at finite chemical potential. This occurs at

$$T_E \simeq 160 \text{ MeV}, \quad \text{and} \quad \mu_E \simeq 270 \text{ MeV}.$$

Explored in the RHIC BES, and at GSI, JINR.

Outline

Why study heavy-ion collisions

The largest context

The phase diagram of QCD

Summary

Observables

General conditions in heavy-ion collisions

Hard probes

Probes of early thermalization

Chemical composition of the final state

Event by event fluctuations

Summary

Some history and future plans

Outline

Why study heavy-ion collisions

The largest context

The phase diagram of QCD

Summary

Observables

General conditions in heavy-ion collisions

Hard probes

Probes of early thermalization

Chemical composition of the final state

Event by event fluctuations

Summary

Some history and future plans

More than $E = mc^2$

Matter is always formed in colliders. In sufficiently hard pp collisions even soft physics can create W/Z bosons; therefore many hadrons. Does this matter reinteract with sufficient strength to thermalize?

If the interaction strength is large enough, then two-body scattering cross sections σ can be large. The mean free path

$$\lambda \propto (n\sigma)^{-1},$$

where n is the number density of particles. If $\lambda\sqrt{n} \gg 1$ then final state collisions are numerous, and matter may thermalize.

When $\sqrt{S} \simeq 20$ GeV, $\sigma \simeq 40$ mb, and $n \geq 5/\text{fm}^3$ may be enough. Heavy-ion collisions increases n by some power of A , so heavy-ion collisions may thermalize. At the LHC, n is large, so thermalization is easier, and even high multiplicity pp collisions may thermalize.

General conditions

The flavour quantum numbers of the incoming hadrons are essentially contained in hard (valence) quarks. At large \sqrt{S} , this means that most of the time these valence quantum numbers do not scatter into the central rapidity region, and are carried forward into the fragmentation region.

Significant fraction of the energy will be carried by all the soft partons together. These will generally scatter and stay in the central rapidity region. If this matter approximately thermalizes, then it makes the fireball which is the object of heavy-ion studies. The net-baryon and flavour content is small, the energy content increases with \sqrt{S} .

At $\sqrt{S} \simeq 1$ GeV, baryon interactions cannot be analyzed in terms of quarks. In this region the fireball may contain baryon and other flavour quantum numbers. The distinction between fireball and fragmentation region may be weak.

Defining collision centrality

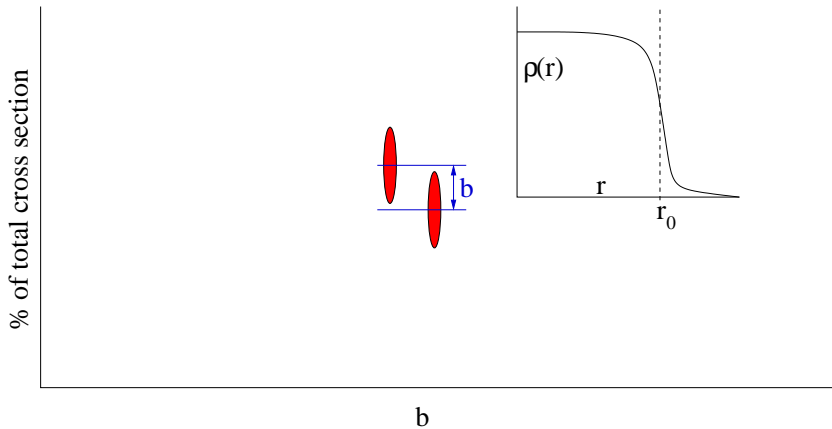

Model required: Glauber, Kharzeev-Levin-Nardi, etc. Direct tests?

Defining collision centrality

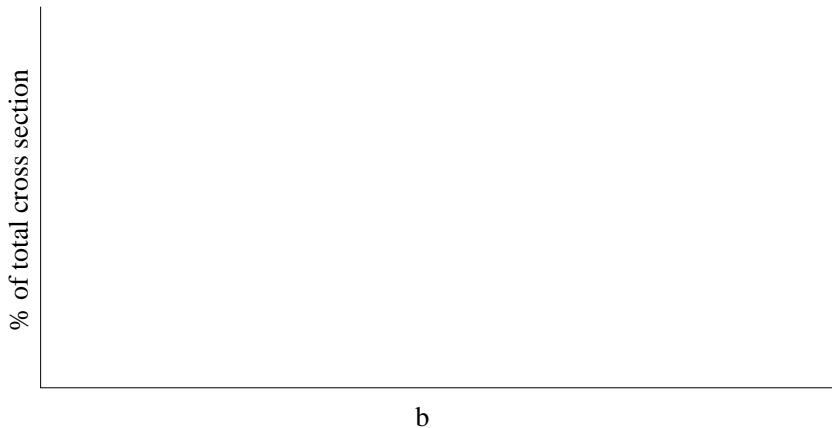

Model required: Glauber, Kharzeev-Levin-Nardi, etc. Direct tests?

Defining collision centrality

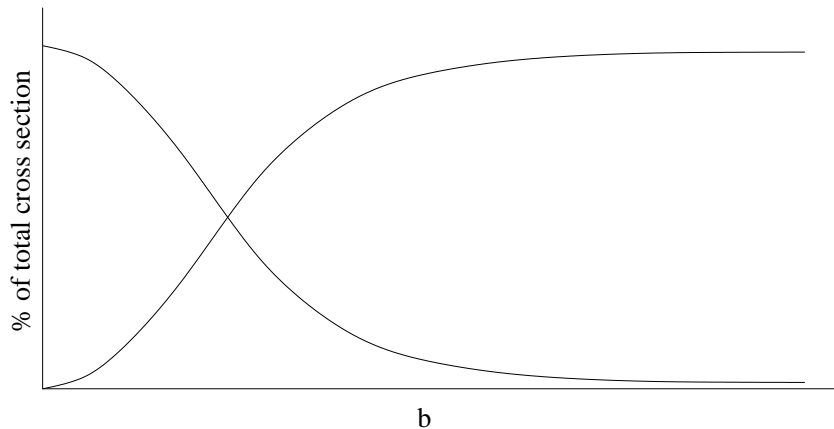

Model required: Glauber, Kharzeev-Levin-Nardi, etc. Direct tests?

Defining collision centrality

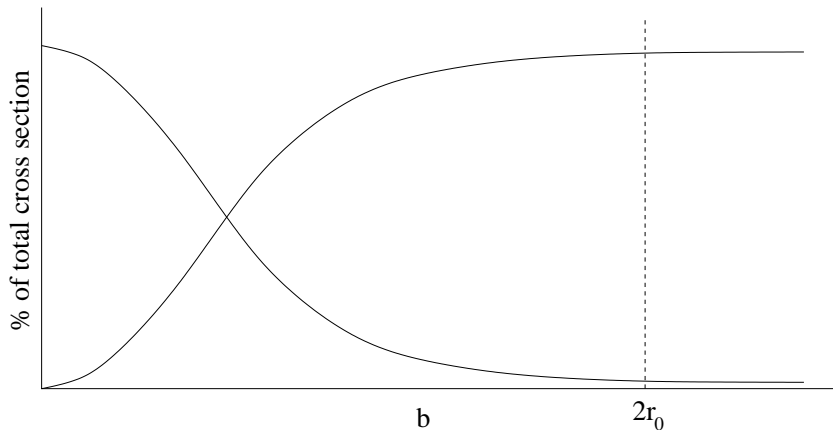

Model required: Glauber, Kharzeev-Levin-Nardi, etc. Direct tests?

Model dependence

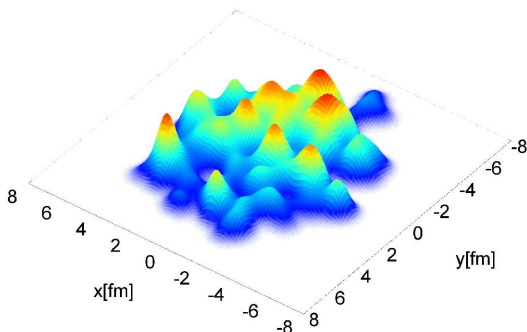

Gale, Jeon, Schenke, Tribedy, Venugopalan, 1209.6330

Transverse energy profiles, 0.2 fm after the collision, in three models of initial states: Glauber,

Model dependence

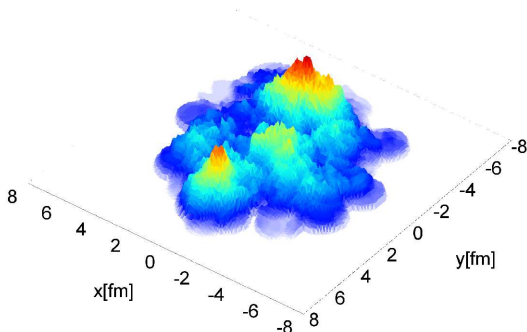

Gale, Jeon, Schenke, Tribedy, Venugopalan, 1209.6330

Transverse energy profiles, 0.2 fm after the collision, in three models of initial states: Glauber, KLN Glasma,

Model dependence

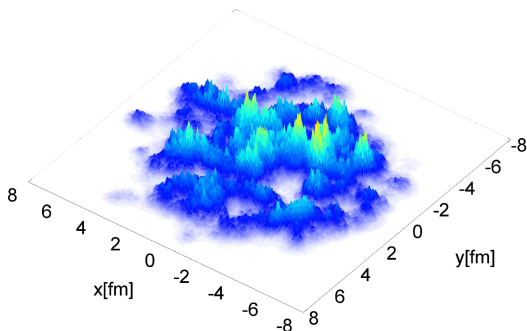

Gale, Jeon, Schenke, Tribedy, Venugopalan, 1209.6330

Transverse energy profiles, 0.2 fm after the collision, in three models of initial states: Glauber, KLN Glasma, IPSat Glasma

Current practise

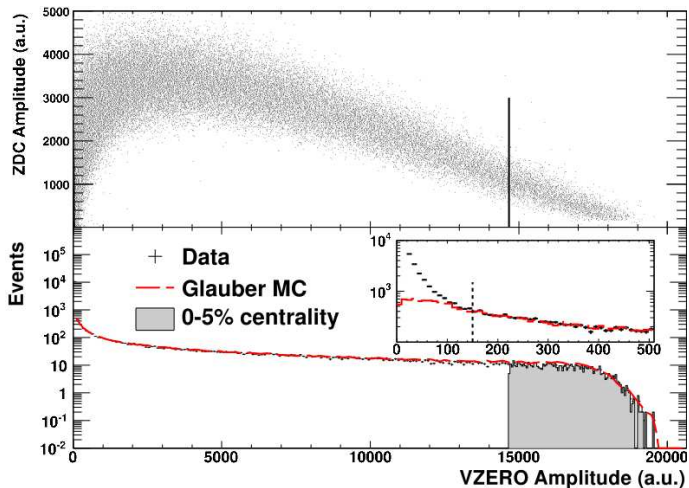

Centrality classes and volume fluctuations

May replace percent of total cross section by percent of any other measure. Main use is to select bins of fixed centrality. For example, centrality can be characterized by multiplicity, zero degree calorimetry, etc.

How is the bin in the proxy measure related to bins in b ? Model dependent answer. Also, two events with same b may fall into two different centrality classes due to fluctuations in the positions of nuclei.

Nuclear density, $\rho(r)$, is measured in low-energy experiments. There may be many kinds of fluctuations when this is resolved at smaller scales in high-energy experiments: generically called volume fluctuations.

Outline

Why study heavy-ion collisions

The largest context

The phase diagram of QCD

Summary

Observables

General conditions in heavy-ion collisions

Hard probes

Probes of early thermalization

Chemical composition of the final state

Event by event fluctuations

Summary

Some history and future plans

Final state interactions

LHC is an arena of hard QCD: jets, heavy quarks, W/Z bosons, hard γ , H. Typical momentum scale, $Q \simeq \langle x \rangle \sqrt{S} \simeq 500$ GeV. Final state interactions are suppressed in pp collisions because

- ▶ dense hadronic debris separated from probes by large $\Delta\eta$,
- ▶ energy scale of remaining hadronic activity in central rapidity small: $\langle E_T \rangle \simeq \Lambda_{QCD} \simeq 0.3$ GeV.

But in AA collisions this fails if n is large enough. Assume $n = 5/\text{fm}^3$, as before. Actual value at LHC is larger. Assume the jet cone has $R = 0.2$, and that it travels about $\ell = 10$ fm through the fireball of soft particles. Then net energy in the soft hadrons it can interact with is

$$\mathcal{E} \simeq \langle E_T \rangle n R \ell^3 \simeq 300 \text{ GeV}.$$

This is why factorization fails and final state interactions become important. Bjorken, Gyulassy, Wang, ...

Jets

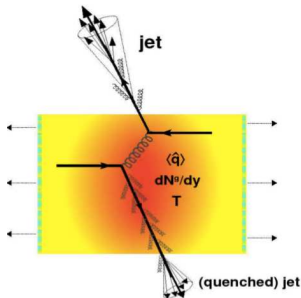

$$R_{AA} = \frac{(1/T_{AA})d^2N_{AA}/dydp_T}{d^2N_{pp}/dydp_T}$$

where T_{AA} measures number of pairs colliding in the AA collision. T_{AA} is model-dependent information. Collision centrality is a relevant variable.

Other quantities of interest:

- ▶ rapidity and angular correlations
- ▶ missing p_T
- ▶ fragmentation functions
- ▶ jet substructure

Jet quenching: final state interactions remove energy from jet. γ , W/Z can serve as calibration.

Vector bosons: probing initial state

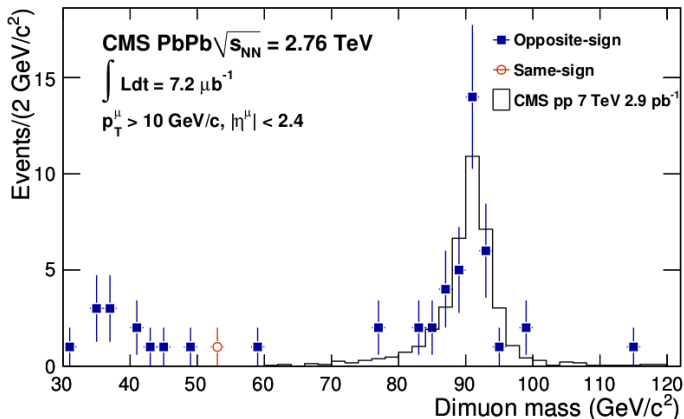

CMS 1102.5435

Measurement tests the model for T_{AA} and models for nuclear dependence of parton densities.

Basic jet quenching measurement

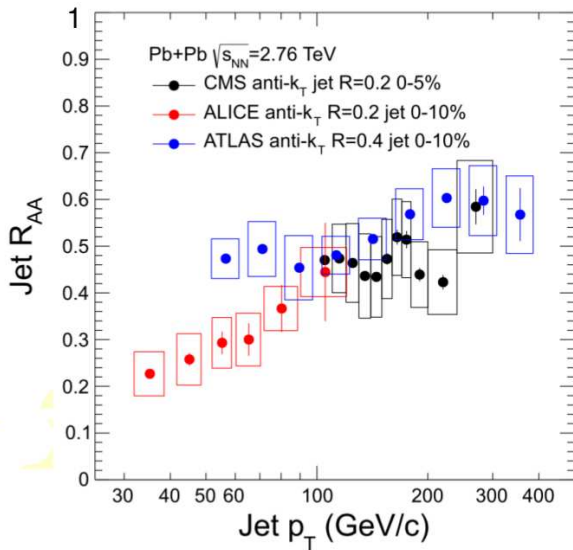

The first theory question

How much energy is lost per unit distance travelled within the plasma:

$$\hat{q} = \frac{1}{L} \int \frac{d^2 p_T}{(2\pi)^2} p_T^2 P(p_T, L).$$

Most extractions give $\hat{q} \simeq 1\text{--}2 \text{ GeV}^2/\text{fm}$, *i.e.*, in the range of interest, $\hat{q}/T^3 \simeq 4\text{--}5$.

Approaches:

- ▶ Weak coupling in QCD **Baier et al, ...**
- ▶ Strong coupling via AdS/CFT **Rajagopal, Wiedemann, ...**
- ▶ Lattice QCD **Majumder, Panero, Rummukainen, ...**
- ▶ Models

Where does the energy go?

R (distance between jet and track)

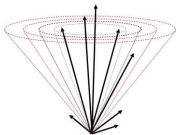

Where does the energy go?

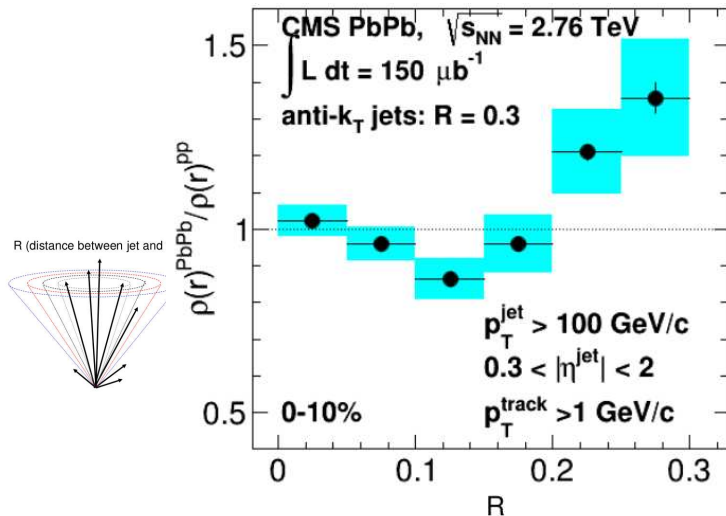

Quarkonium Suppression

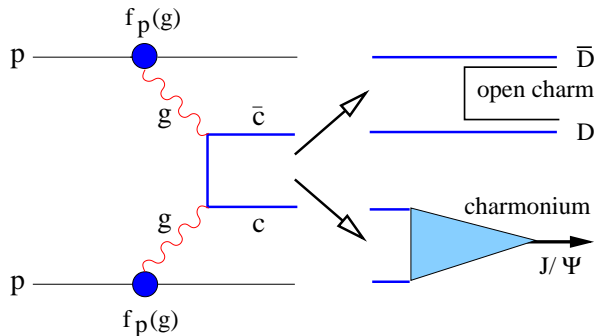

Heavy-quark pair produced initially through a (semi-) hard scattering. Coherence required to produce bound states lost in a medium: characterized by Debye screening length.

Matsui, Satz, PL B178, 416 (1986)

Debye Screening

Static potential between two charges in vacuum:

$$V(r) \propto \frac{1}{r}$$

In a plasma

$$V(r) \propto \frac{\exp(-r/\lambda)}{r}$$

where λ is the Debye screening length. Dimensionally, $\lambda \propto 1/T$.

In QCD vacuum potential between static charges linearly rising; at finite T cut off at distance λ by the same mechanism.

Quark mass, $M \gg T$ and $M \gg \Lambda_{QCD}$, but $T \simeq \Lambda_{QCD}$.

Sequential suppression

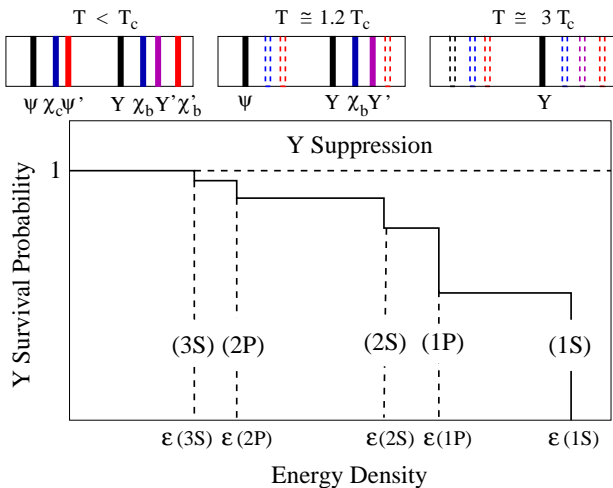

Data

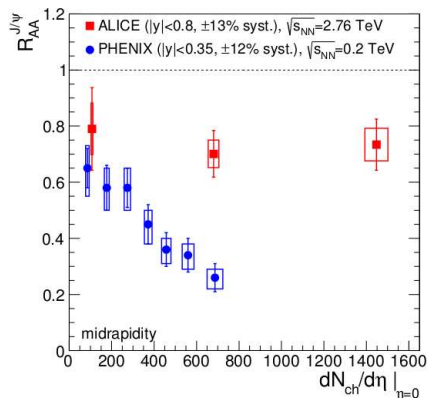

Distinct sign of final state interactions; thermal effects: more suppression at higher energy density. Possible sequential suppression. More detailed information later.

Outline

Why study heavy-ion collisions

The largest context

The phase diagram of QCD

Summary

Observables

General conditions in heavy-ion collisions

Hard probes

Probes of early thermalization

Chemical composition of the final state

Event by event fluctuations

Summary

Some history and future plans

The initial state

- ▶ In AA collisions there are two initial state vectors: initial momentum \mathbf{k} and line of centers of nuclei \mathbf{b} . So azimuthal symmetry around \mathbf{k} is broken, and distributions may depend on both η and ϕ .
- ▶ The plane defined by \mathbf{k} and \mathbf{b} is called the reaction plane.
- ▶ Fourier transforms of velocity distributions with respect to ϕ are called flow coefficients. **Ollitrault, ...**
- ▶ On the average there is no difference between “above” and “below” the reflection plane, so only even flow coefficients exist.
- ▶ Event-by-Event (E/E) there may be more nucleons on one side of the plane than another, so odd flow coefficients will exist.
- ▶ Flow coefficients yield combined information on initial state and evolution of fireball. E/E fluctuations of flow coefficients yield more refined information on the initial state. **Srivastava, ...**

Compilation of data

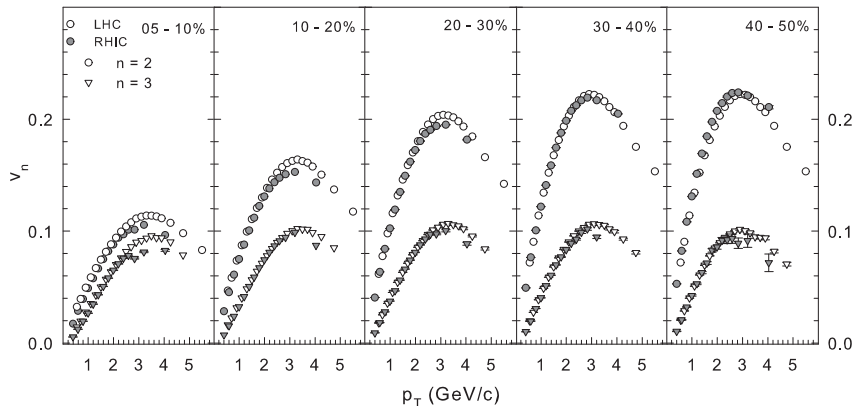

Lacey et al, 1207.1886

An unexpected scaling

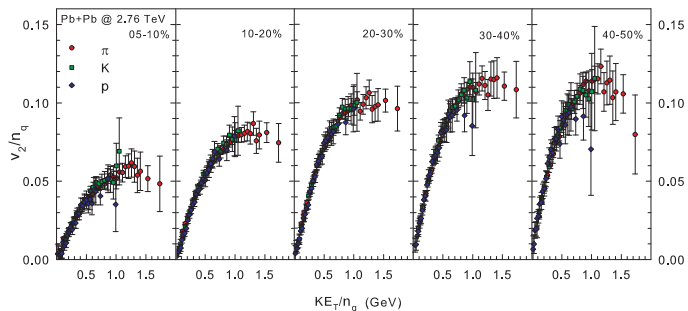

At RHIC v_2/n_q for π , K, p, etc. scale as a function of KE_T/n_q , where n_q is the number of valence quarks. At LHC requires KE_T of p to be adjusted for larger speed of sound at LHC.

Lacey et al, 1207.1886.

Hydrodynamics appears

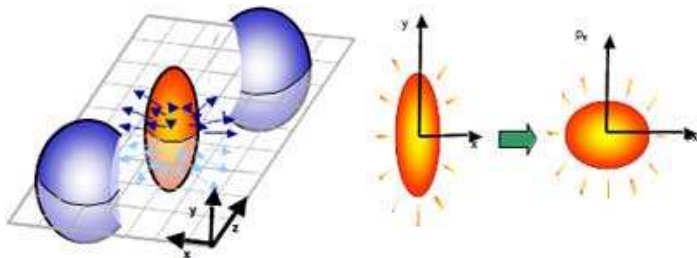

Arguments: initial positional anisotropies in multiplicities, ϵ_n .

Actual observation: final velocity anisotropy, v_n .

Important to note: larger v in the direction where n was squeezed.

This implies large rescattering: possibly hydrodynamics.

What is hydrodynamics

Sufficient amount of scattering in a system leads to thermalization. In thermal equilibrium many quantities are zero or constant. For example, Fourier coefficients of energy:

$$\langle E(\eta, \phi) \rangle_\phi = \mathcal{E}(\eta), \quad \langle E(\eta, \phi) \cos n\phi \rangle_\phi = 0.$$

Also, pressure equilibrium implies

$$\langle p_x(\eta, \phi) \rangle_\phi = \langle p_y(\eta, \phi) \rangle_\phi = \langle p_z(\eta, \phi) \rangle_\phi.$$

Thermal matter is characterized entirely by T , μ , and the equation of state, $E(T, \mu)$ and $P(T, \mu)$.

The dynamics of approach to equilibrium is called hydrodynamics. This is characterized by a few other constants, for example, the viscous coefficients.

Does matter nearly thermalize?

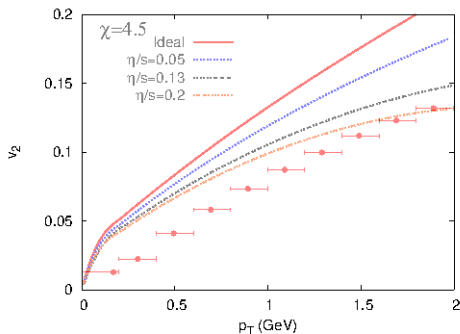

Dusling, Teaney, 0710.5932

One way to answer this question is to crank hydrodynamics to get $v_n(\epsilon_n)$. Approximately ok. What are the remaining discrepancies due to: inadequate hydrodynamics, or model of initial state?

Outline

Why study heavy-ion collisions

The largest context

The phase diagram of QCD

Summary

Observables

General conditions in heavy-ion collisions

Hard probes

Probes of early thermalization

Chemical composition of the final state

Event by event fluctuations

Summary

Some history and future plans

Hadron chemistry

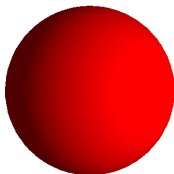

If there are reactions in the final state, then hadron chemistry can play a major role. Rates of reactions such as



determine whether hadron chemistry comes to equilibrium. **Cleyman, Redlich, ...**

When does chemistry freeze out?

Basic observables are the spectra of identified particles; from this one gets yields. Relative yields of hadrons is the outcome of hadron chemistry.

At early times, fireball is a reactive fluid: requires coupling of hydrodynamics with diffusion and flavour chemistry. Reaction rates depend on local densities as well as rates of mixing. Mixing controlled by advection (stirring) and diffusion. Need to understand the relative importance of the two effects.

Kinetic equations more complicated: need numerical treatment, but many parameters fed into the code. Need to understand model kinetic equations and average behaviour first; then thermal fluctuations.

A well-stirred fireball

If the fireball is constantly stirred then it is enough to examine chemical rate equations. A toy model is:

$$\begin{aligned}
 \dot{p} &= -\gamma(p\pi^0 - n\pi^+) - \gamma'(p\pi^- - n\pi^0) + \dots, \\
 \dot{n} &= \gamma(p\pi^0 - n\pi^+) + \gamma'(p\pi^- - n\pi^0) + \dots, \\
 \dot{\pi}^0 &= -\gamma(p\pi^0 - n\pi^+) + \gamma'(p\pi^- - n\pi^0) + \dots, \\
 \dot{\pi}^+ &= \gamma(p\pi^0 - n\pi^+) + \dots, \\
 \dot{\pi}^- &= -\gamma'(p\pi^- - n\pi^0) + \dots.
 \end{aligned}$$

Rate constants γ and γ' from experiment. Realistic equations contain many, some unmeasured. The equilibrium concentrations are given by

$$\frac{p}{n} = \frac{\pi^+}{\pi^0} = \frac{\pi^0}{\pi^-} \quad (= \zeta).$$

ζ is the isospin fugacity. Since $\pi^+/\pi^- = \zeta^2$, if we set $\zeta \simeq 1$, then $\mu_I = T \log \zeta \simeq 0$.

Shaken or stirred?

Flavour chemistry changes due to reactions controlled by densities and diffusion or mixing. Which is more important is controlled by Peclet's number

$$\text{Pe} = \frac{Lv}{D} = \frac{Lv}{\xi c_s} = \left(\frac{L}{\xi} \right) M.$$

When $\text{Pe} \ll 1$ diffusion dominates; when $\text{Pe} \gg 1$ it is mixing.

Crossover regime when $\text{Pe} \simeq 1$.

New length scale: defines when advection becomes comparable to diffusion—

$$L \simeq \frac{\xi}{M}.$$

Since longitudinal flow has $M \leq \sqrt{3}$, for baryons, $L \simeq 0.3$ fm and for strange particles, $L \simeq 0.5$ fm. Initial advection may be important for rapid chemical equilibration, but over most of the history of the fireball chemistry is governed by diffusion.

Can the K and π freeze separately?

Indirect transmutations of K and π involve strange baryons in reactions such as $\Omega^- + K^+ \leftrightarrow \Xi^0 + \pi^0$. These have very high activation thresholds.

Direct transmutations can proceed through the strong interactions such as $K^+ + K^- \leftrightarrow \pi^+ + \pi^-$. These are OZI violating reactions; slower than generic strong-interaction cross sections.

Direct transmutations through weak interactions are not of relevance in the context of heavy-ion collisions.

There is no physics forcing K and π to freezeout together. But K and ϕ are resonantly coupled, so freeze out together.

Chatterjee, Godbole, SG, 1306.2006

LHC lowest energy

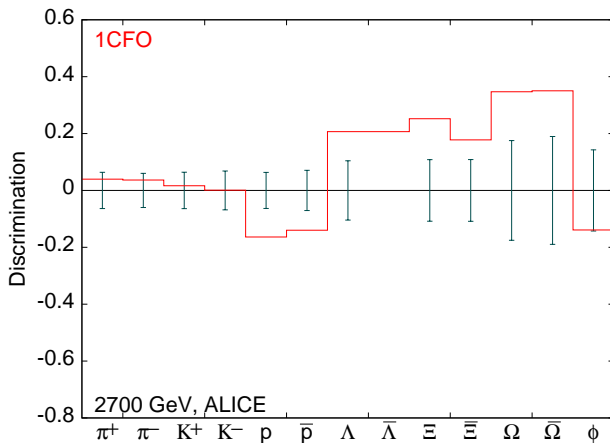

Large non-thermal fluctuations? Bleicher et al, Becattini et al

LHC lowest energy

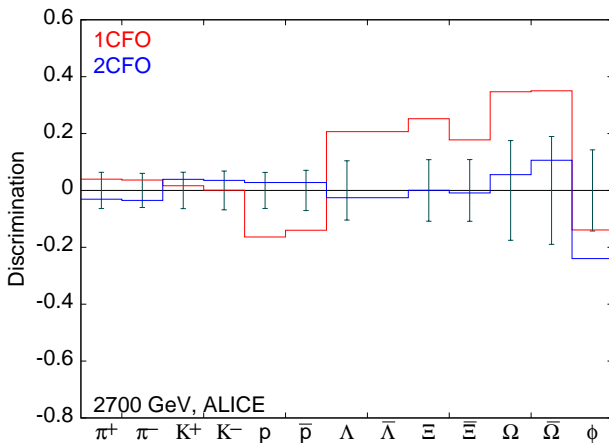

Large non-thermal fluctuations? [Bleicher et al](#), [Becattini et al](#)
 Or normal late-stage kinetics? [Chatterjee, Godbole, SG, 1306.2006](#)

RHIC highest energy results

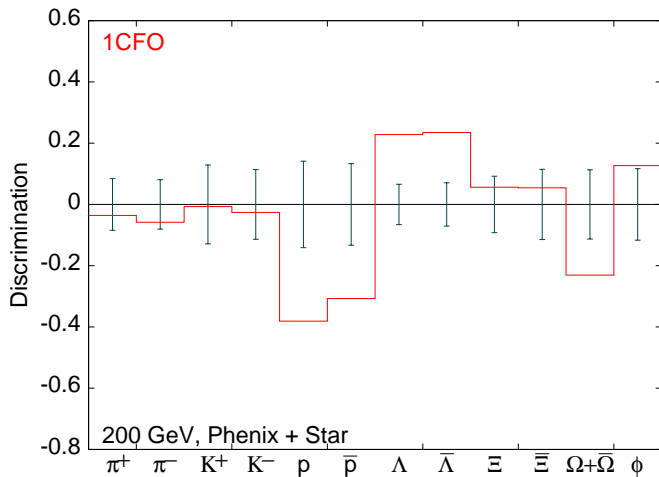

RHIC highest energy results

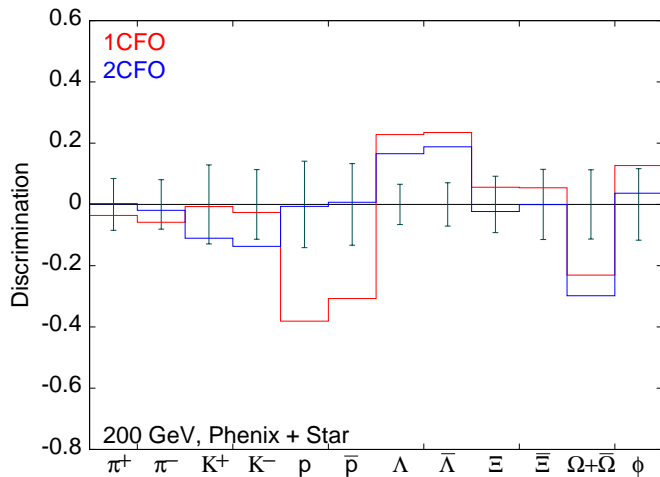

RHIC highest energy results

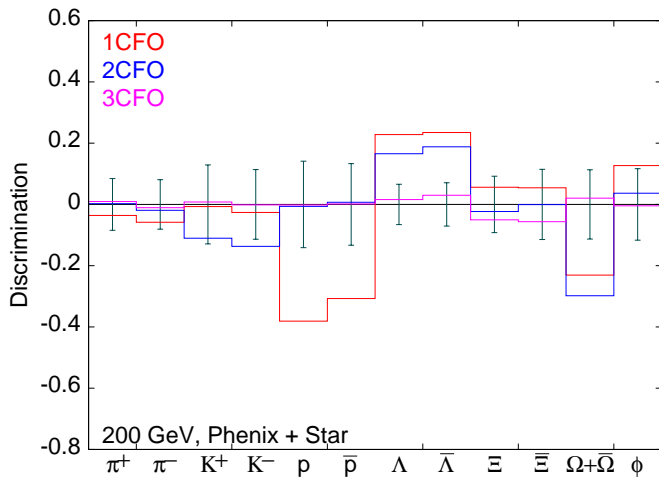

The freezeout curves

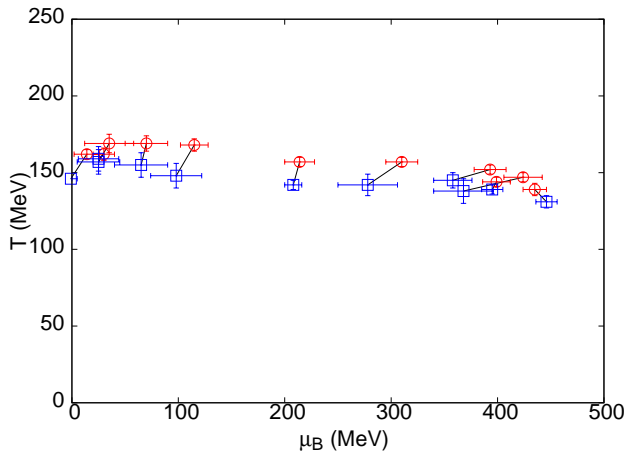

The freezeout curves

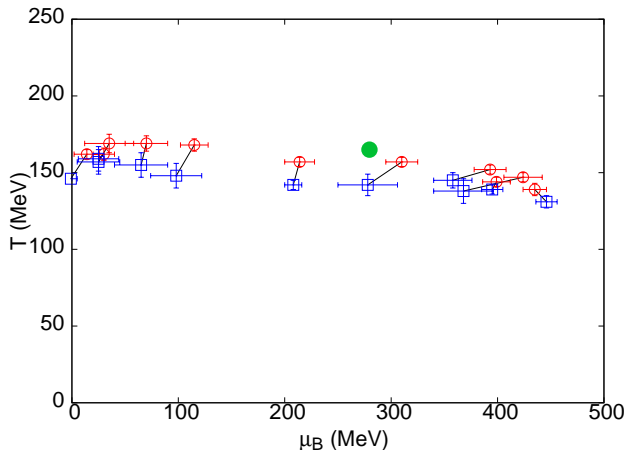

Freeze out curves pass close to the QCD critical point: rationale for RHIC BES, experiments in GSI and JINR.

Quarkonium freezeout

Υ family yield in AA collisions at LHC differs from pp collisions at same \sqrt{S} . Quark mass, $M \gg T \simeq \Lambda_{QCD}$. However binding energy $B \simeq T$, so large effects.

If the thermal lattice QCD results on stepwise suppression are a good guide to understanding Υ , then possible states of $\bar{b}b$ should be in thermal equilibrium. Does the data support this?

In a thermal model examine

$$r[\Upsilon(n\ell)] = \frac{dN_{AA}^{\Upsilon(n\ell)} / dy dp_T}{dN_{AA}^{\Upsilon(1S)} / dy dp_T}.$$

One parameter: Υ freezeout temperature.

Data vs model

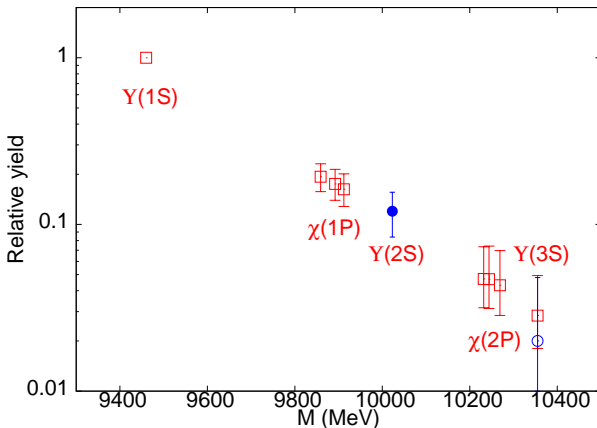

SG and Sharma, 1401.2930

$$T_f^{\Upsilon} = 222_{-29}^{+28} \text{ MeV}$$

Freezeout always depends on the chemical kinetics. Expect

Outline

Why study heavy-ion collisions

The largest context

The phase diagram of QCD

Summary

Observables

General conditions in heavy-ion collisions

Hard probes

Probes of early thermalization

Chemical composition of the final state

Event by event fluctuations

Summary

Some history and future plans

Conserved quantities fluctuate

In thermodynamics of infinite matter (Avogadro number of particles) properties such as energy, pressure, magnetization (spin), particle number are fixed by T and μ .

Statistical mechanics deals with (relatively) small systems, and can discuss fluctuations in each of these, in a grand canonical ensemble (GCE). The specific heat, compressibility, susceptibility, number susceptibility, are thermodynamic quantities, but determine the amount of statistical fluctuations. Gaussian only, $\Delta E \propto C_V \sqrt{V}$.

In nano-materials fluctuations are even more important: large deviations from Gaussian fluctuations, higher cumulants controlled by non-linear susceptibilities. Heavy-ion fireball is an example.

The fireball and fluctuations

In a full fireball (4π detection) fluctuations of conserved quantities can only be due to initial volume fluctuations.

With limited rapidity coverage one observes only a part of the fireball. The remainder acts like a heat bath to the part observed, so GCE.

Each recorded event is one member of the ensemble, so event-by-event fluctuations are precisely equivalent to the fluctuations of statistical mechanics.

So cumulants of the distributions are related to the non-linear susceptibilities computed in lattice QCD. Therefore direct comparison of experiment and lattice QCD!

SG, 0909.4630

Near Gaussian Fluctuations

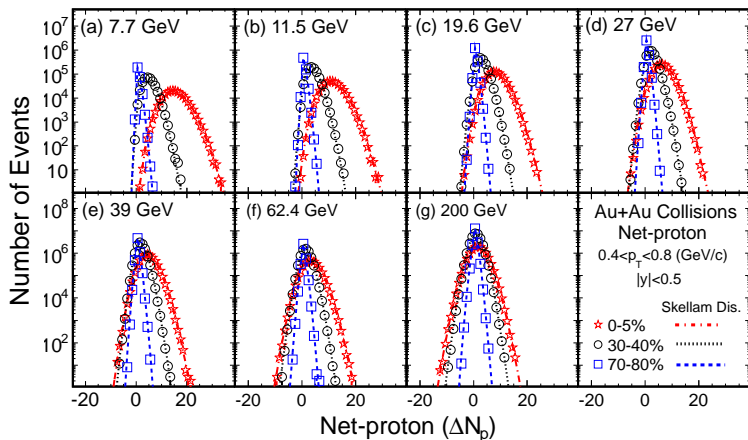

STAR 1309.5681

Near Gaussian Fluctuations

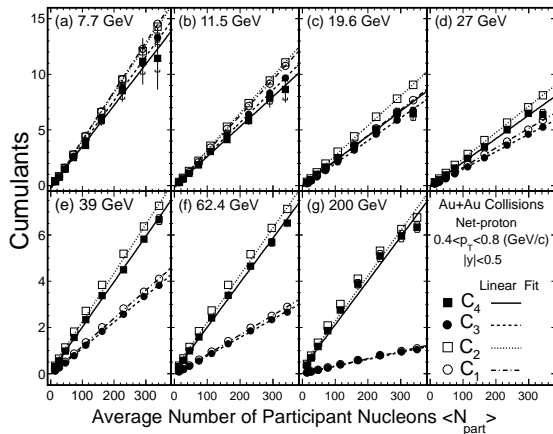

STAR 1309.5681

Comparison of data and QCD

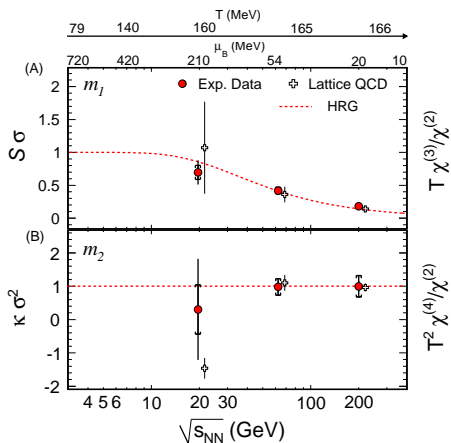

Outline

Why study heavy-ion collisions

The largest context

The phase diagram of QCD

Summary

Observables

General conditions in heavy-ion collisions

Hard probes

Probes of early thermalization

Chemical composition of the final state

Event by event fluctuations

Summary

Some history and future plans

Summary

- ▶ Initial state of fireball incompletely characterized. Must use experiment to validate models: Glauber, KLN glasma, *etc.*. Important input to everything else.
- ▶ Flow (v_n) well-measured, lots of systematics. Evidence for matter reinteractions; may be very good probe of hydro and thermalization.
- ▶ Good experimental control of jet quenching, but \hat{q} from lattice QCD just beginning. Interaction between jets and flow.
- ▶ R_{AA} clearly non-trivial. $r[\Upsilon]$ and $r[\psi]$ are important.
- ▶ Chemical equilibration evidence of final state thermalization. LHC gives important insight into chemical kinetics.
- ▶ Quantitative agreement of lattice and expt for fluctuations; good tool to search for the critical point.
- ▶ Many other interesting probes: see proceedings of Quark Matter 2011, 2013, 2014.

Outline

Why study heavy-ion collisions

- The largest context

- The phase diagram of QCD

- Summary

Observables

- General conditions in heavy-ion collisions

- Hard probes

- Probes of early thermalization

- Chemical composition of the final state

- Event by event fluctuations

- Summary

Some history and future plans

Beginnings

1. A conjecture of a phase diagram in Enrico Fermi's monograph on thermodynamics (1936).
2. Hagedorn finds a limiting temperature for hadrons; conjectures a phase transition in matter (1965).
3. Meeting in Bielefeld gels the field; soon first computations of the phase diagram of QCD (1980).
4. In 1985 US Long Range Plan for Nuclear Physics recommends the setting up of RHIC at Brookhaven Lab.
5. In 1987 first school on heavy-ion physics held in India; first school in China was in 1983.
6. In 1987 CERN SPS collides OO at $\sqrt{S} = 17$ GeV. SS and PbPb follow.
7. In 1990 ECFA meeting on LHC held in Aachen, heavy-ion physics part of the plan.

Lessons from SPS

Rapid expansion of the fireball, v_2 , excess strangeness and chemical equilibration, broadening of ρ peak, suppressed J/ψ , differences between peripheral and central collisions: all point to a fireball being formed.

The combined data coming from the seven experiments on CERN's Heavy Ion programme have given a clear picture of a new state of matter. This result verifies an important prediction of the present theory of fundamental forces between quarks. It is also an important step forward in the understanding of the early evolution of the universe. We now have evidence of a new state of matter where quarks and gluons are not confined. — Luciano Maiani, 10 Feb 2000

Was SPS energy close to the critical point, making interpretation hard?

Discoveries at the RHIC

Particle yields and spectra, v_2 , correlations, jet quenching show

- ▶ strong evidence for non-hadronic matter,
- ▶ initial energy densities in excess of lattice QCD predictions for transition to quark matter,
- ▶ significant reinteractions, *i.e.*, very short mean free paths.

We know that we've reached the temperature and energy density predicted to be necessary for forming such a plasma. [However] this is fluid motion that is nearly 'perfect'. — Sam Aronson, 18 April, 2005

Biggest surprise was the short scale for thermalization; implying the near lack of turbulence in the fluid. Remains under investigation.

The RHIC energy scan and CBM@FAIR

First direct comparison of lattice QCD and experiments: fluctuations of conserved quantities; used to set the scale T_c .

Establishing the existence of a QCD critical point would be much more significant than setting the scale. In 2010, RHIC started a program to search for the QCD critical point. — Hans Georg Ritter, 23 June, 2011

The RHIC beam energy scan continues to refine the region within which signals for the QCD critical point seem to arise.

Future discovery potential

- ▶ GSI, JINR: low energy machines explore high chemical potential. Explore the phase diagram of QCD, and theoretical computations of the physics of neutron stars. *What are the properties of baryon-rich matter?*
- ▶ LHC: Ideal machine for exploring jet phenomena: coupling between soft and hard QCD modes; transport properties of the QCD plasma; already discovered interesting new physics of high-multiplicity pp events. *What are the properties of the baryon-free QCD plasma, how does it arise?*
- ▶ eRHIC: Explore the initial state. Low- x parton densities expected to saturate (glasma); new and unexplored regime of physics. *What is the structure of protons and nuclei, what initial conditions does it provide for heavy-ion collisions?*