

# QUARTIC Update

Andrew Brandt (UT-Arlington), Mike Albrow (FNAL),  
Jim Pinfold (Alberta)

Preliminary UTA drawing  
of Mike Albrow's concept for  
a fast time resolution  
Cerenkov counter:

Baseline design  
has  $6\text{mm}^2$  rods

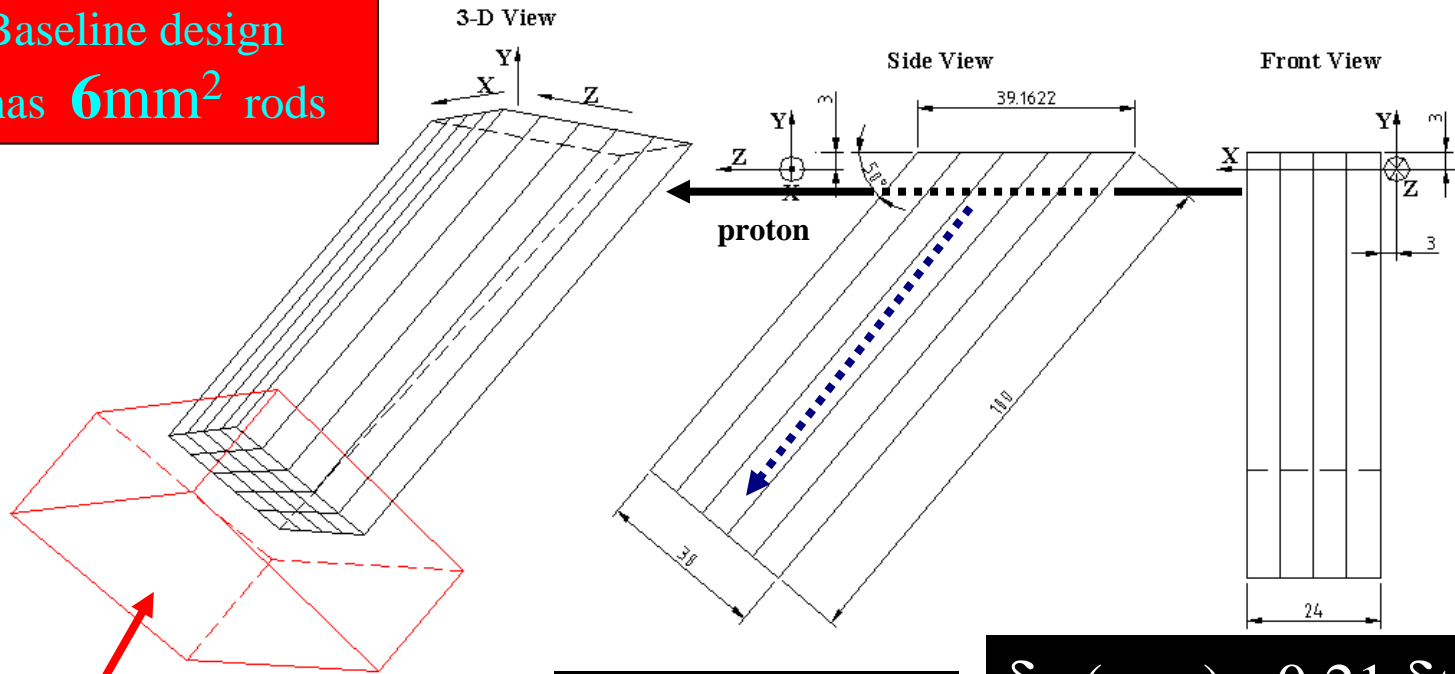
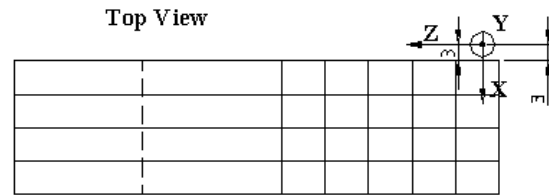

Microchannel plate PMT

$$z=c(TR-TL)/2$$

$$\delta z \text{ (mm)} = 0.21 \delta t \text{ (psec)}$$

(2.1 mm for  $\delta t=10$  psec)

# UTA Funding News

- Submitted DOE ADR 12/15/05  
\$100k/2 years; June notification, elec+students
- Submitted internal pre-proposal for Texas ARP;  
11/30/05 approved for ARP submission (12/79!)  
2/14/05 full proposal; 4/20/05 decision;  
**FUNDED!**  
5/15/05 funds \$100k/2 years  
mechanics+pulser+students

# 10 Psec Workshop April 28/29 at UTA

<http://www-hep.uta.edu/~brandta/uta-pico/uta-pico.html>

- Follow up on visit to SLAC to meet Jerry Va'vra and very successful Pico-Second Timing Hardware Workshop at University of Chicago Nov. 18 2005 (UC focussed on large TOF, but led to valuable contacts)
- **This UTA workshop was dedicated to issues in fast TOF detectors O(10 psec), with a focus on near beam detectors at the LHC. Special attention was given to Burle/Photonis MCP-PMT performance and readout electronics.**
- Of specific interest to FP420 is electronics and other issues involved in achieving 10-15 psec resolution, status of tube development, and fostering collaboration

# Agenda

- **April 28**
- **1. Jim Horwitz (UTA) (10')** Welcome
- **2. Andrew Brandt (UTA) (30')** Workshop goals. QUARTIC.
- **3. Luc Bonnet (Louvain) (30')** GASTOF
- **4. Henry Frisch (Univ. Chicago) (20')** Large Area ps TOF systems
- **5. Jerry Va'vra (SLAC) (40')** MCP-PMT studies
- **6. Paul Hink (Burle) (30')** Burle Update
- **7. All (20')** Discussion
- **8. Mike Albrow (Fermilab) (10')** Timing references
- **9. Jim Pinfold (Univ. Alberta) (20')** QUARTIC timing circuit
- **10. All (30')** Discussion of fast timing circuits, amplis, Burle tubes, Collaboration UTA/UC/SLAC/UA etc.
- **11. All (xh00')** More discussion, open ended
- **April 29**
- QUARTIC planning/TB

# New Drawings

courtesy of:  
Jaak Lippma  
Helsinki

•Sawtooth easier to fabricate

•8 rods in z

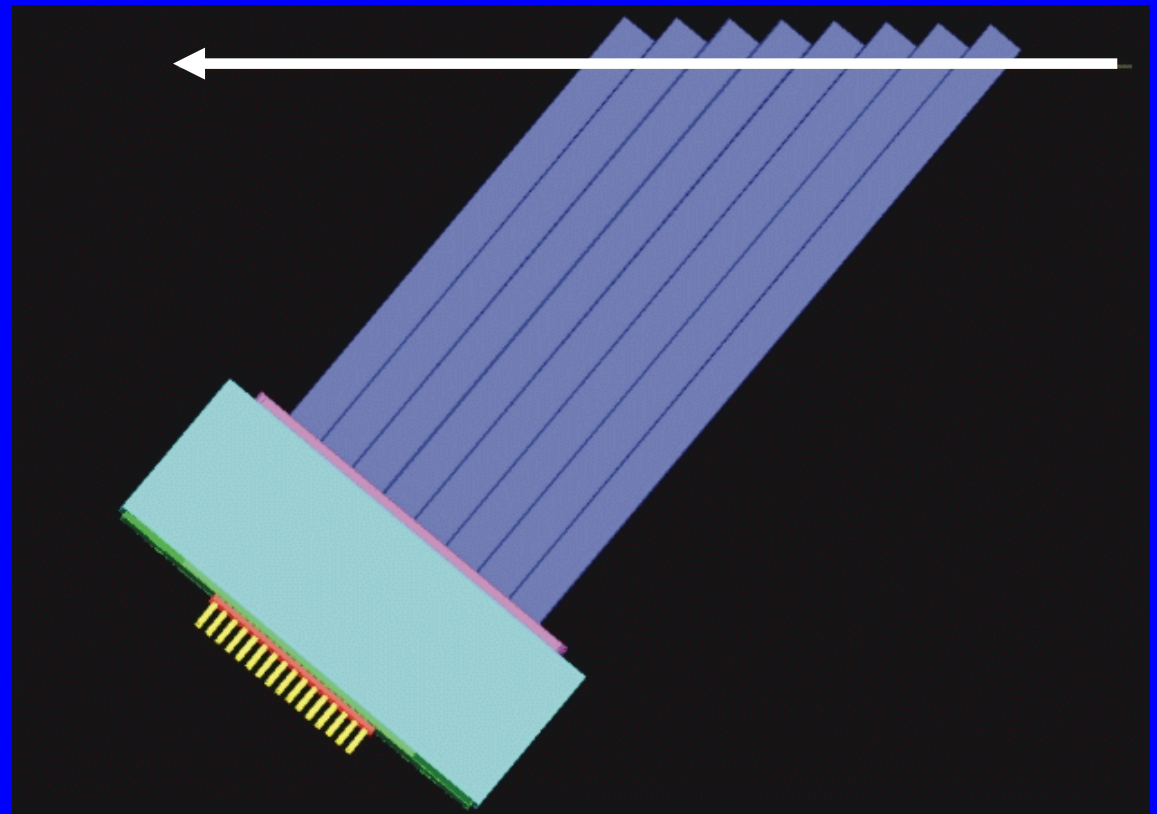
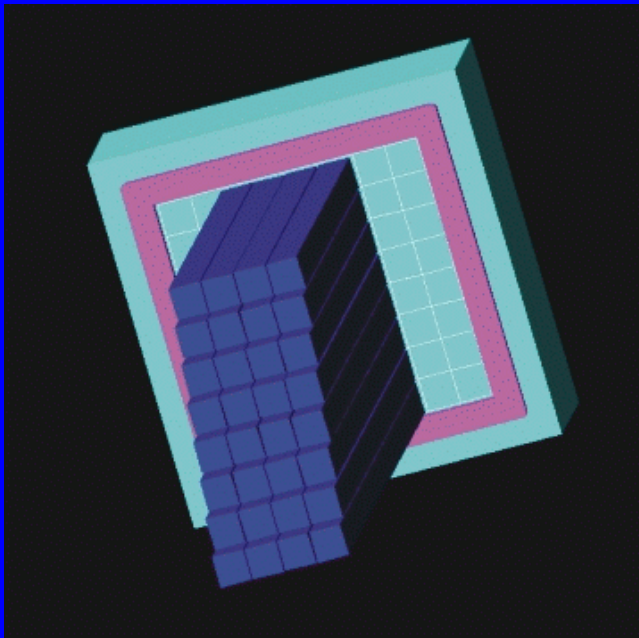
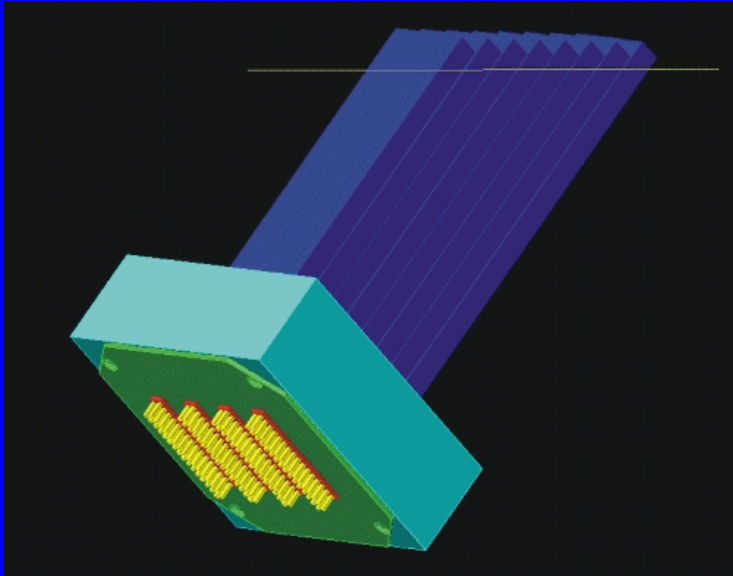

# QUARTIC Background Rejection (UTA)

- 1) 2 single diffractive protons overlaid with a hard scatter (1% of interactions have a proton at 420m)

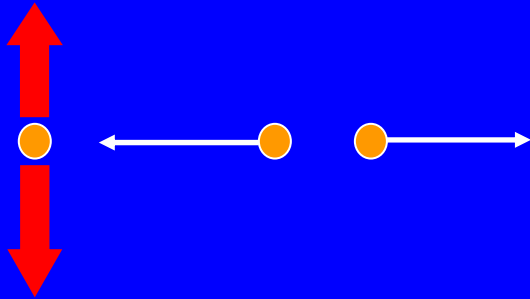

97.4% of events primary vertex and fake vertex from combining proton times more than 2.1mm ( $1\sigma$ ) apart ; 94.8% if 20 psec

- 2) double pomeron overlaid with a hard scatter

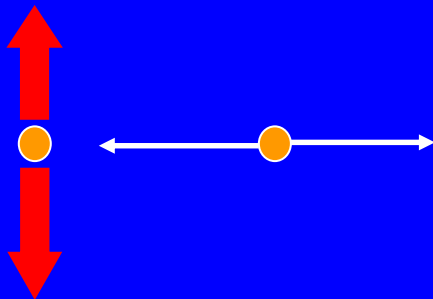

97.8% of time vertices more than 2.1mm apart; 95.6% if 20 psec

- 3) hard SD overlaid with a soft SD

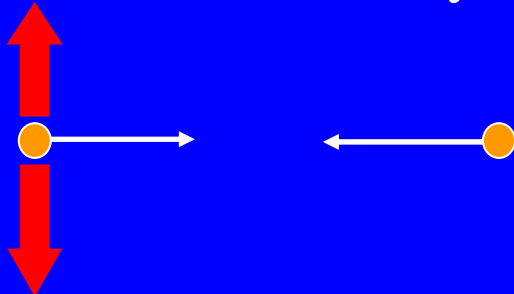

95.5% of time primary vertex and fake vertex more than 2.1mm apart; 91.0% if 20 psec

# QUARTIC Design

- Baseline detector: 4x8 6mm square rods of fused silica
- In z consider 4@12 mm instead of 8@6 mm
- In x consider 16 x 1.5 mm (needs 1032 tube)
- Consider limiting wavelength range
- Larger n to get more light
- Gallium arsenide to improve QE for visible
- Surfaces aluminized or spaced

Continuing studies while awaiting definitive answer from simulations (GEANT) and/or test beam:

Time resolution for the full detector system:

1. Intrinsic detector time resolution
2. Jitter in PMT's
3. Electronics (TDC)

# Preliminary Time Distributions (UTA):

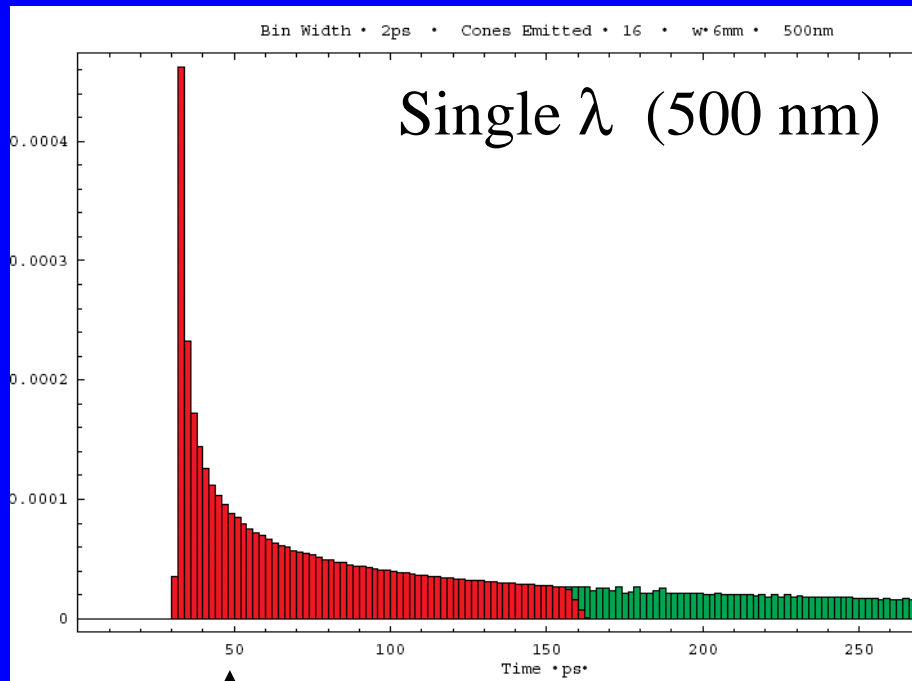

50 psec

Not enough light in leading edge;  
peak too wide!

**red** = totally internally reflected light  
**green** = extra light if aluminized

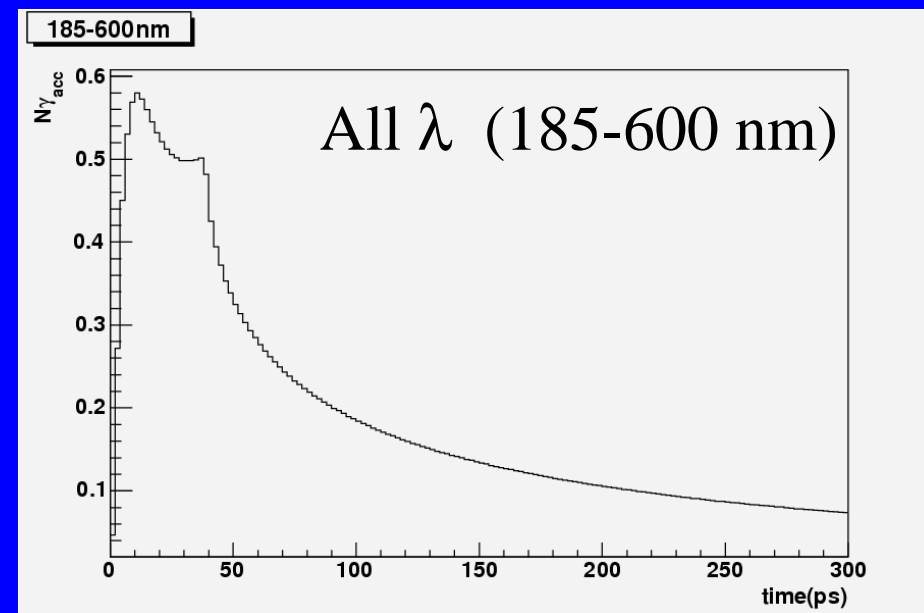



# Time Distributions by Wavelength (UTA):

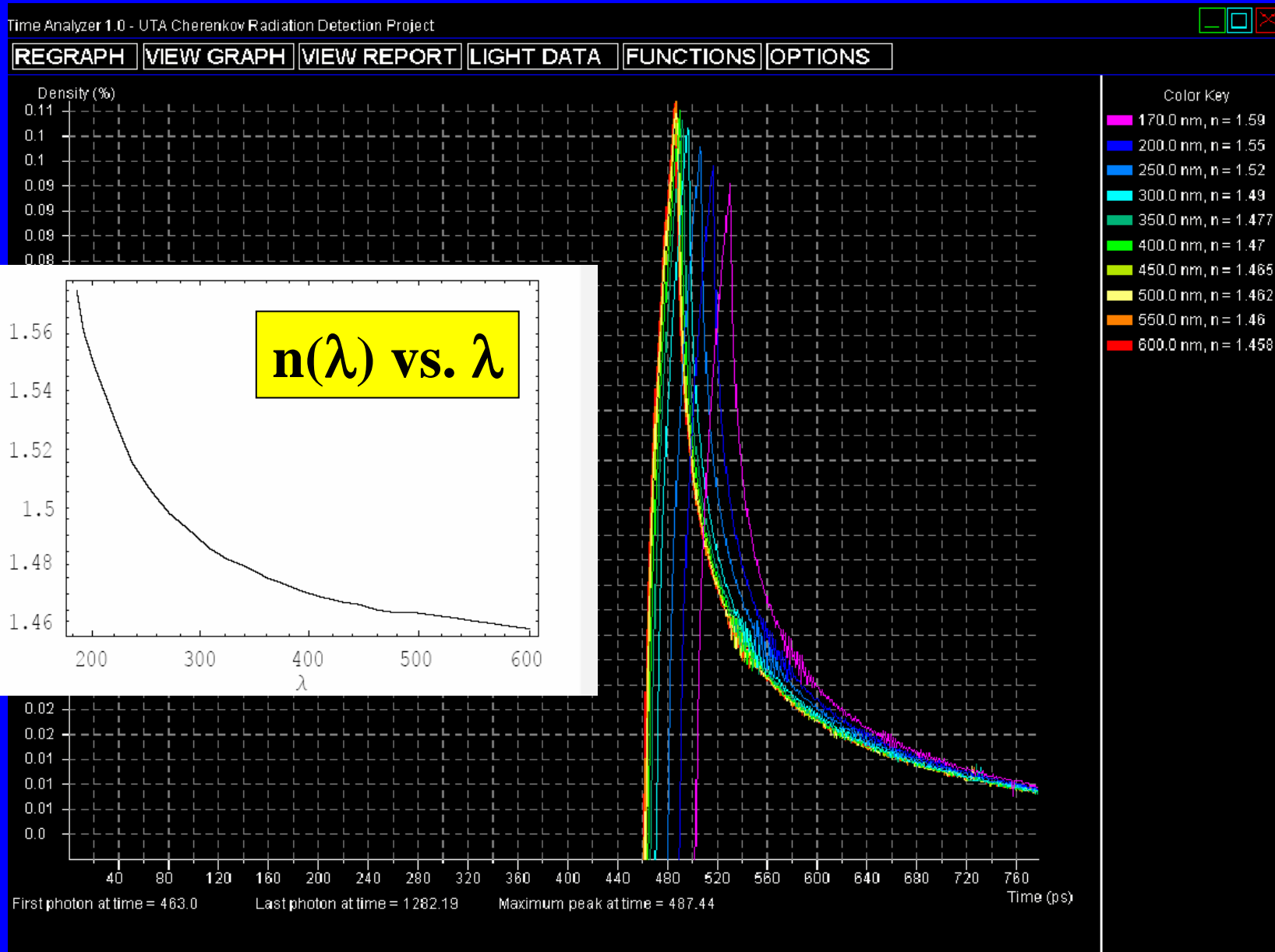

# Cerenkov Light in Fused Silica with Filtering

Blue < 250nm < Red

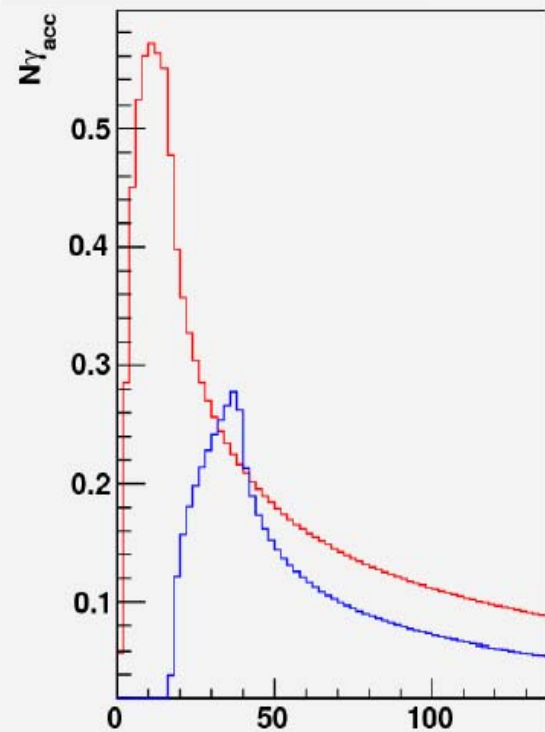

**FIRST 20ps**      4.4 photons  
                          1.9 photon

**WIDTH**            30 ps  
                          34 ps

Blue < 300nm < Red

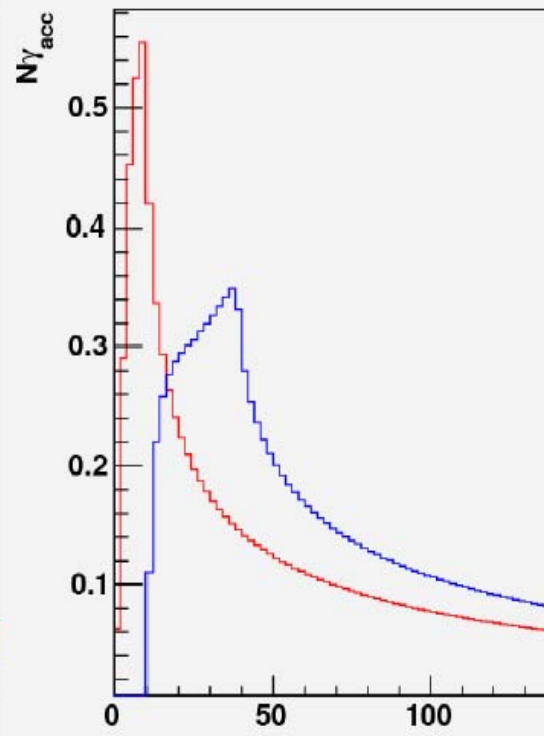

**3.4 photons**  
                          2.7 photons

**18 ps**  
                          48 ps

Blue < 350nm < Red

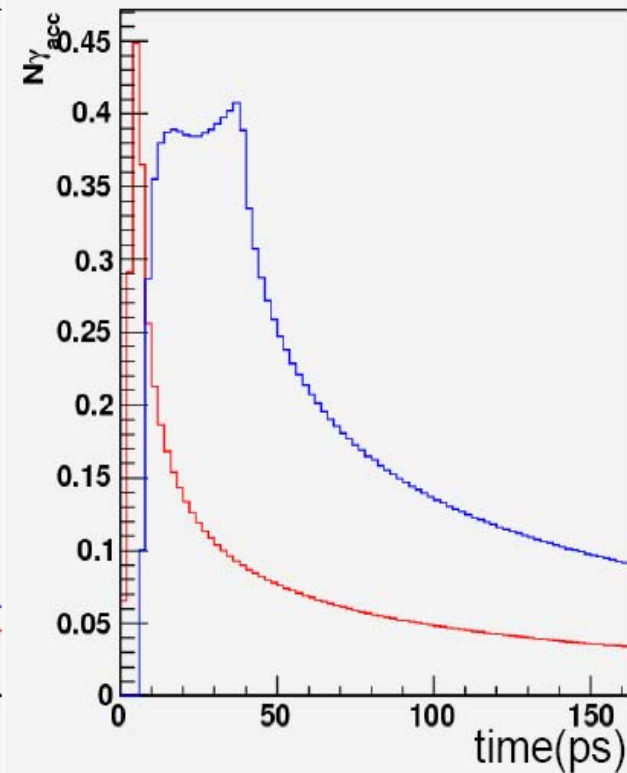

**2.3 photons**  
                          3.4 photons

**12 ps**  
                          56 ps

# Filter Solution?

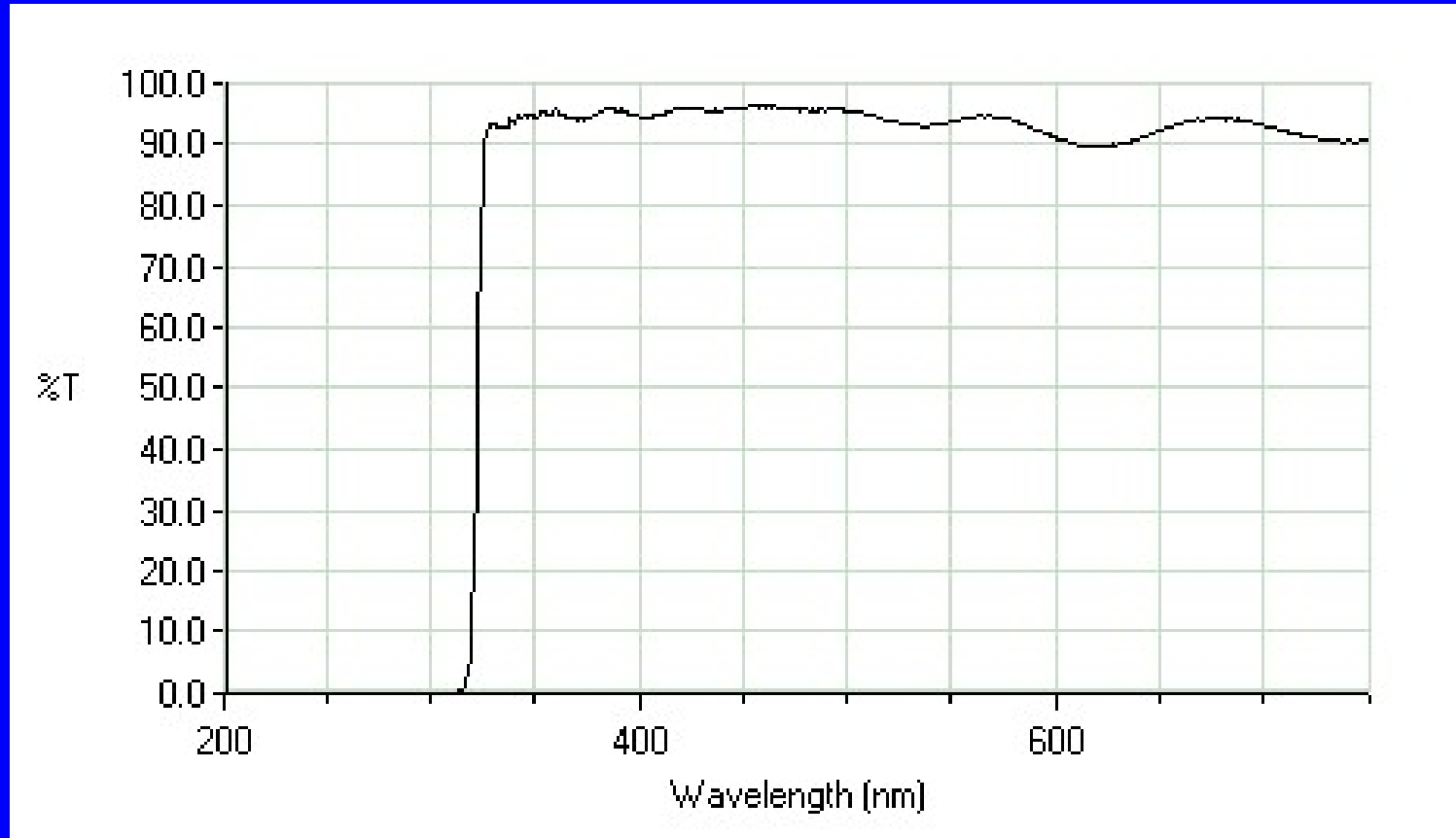

\$?

- Chroma Technology Corp
- <http://www.chroma.com>

## Some Variations

- Larger  $n$  (1.8) does not give more timely light, larger angle so less effective width, a little more light but later
- 12 mm bars give twice the fast light (about 7 photons for  $>300\text{nm}$  case)

# Mini-Bars

Blue<300<Red

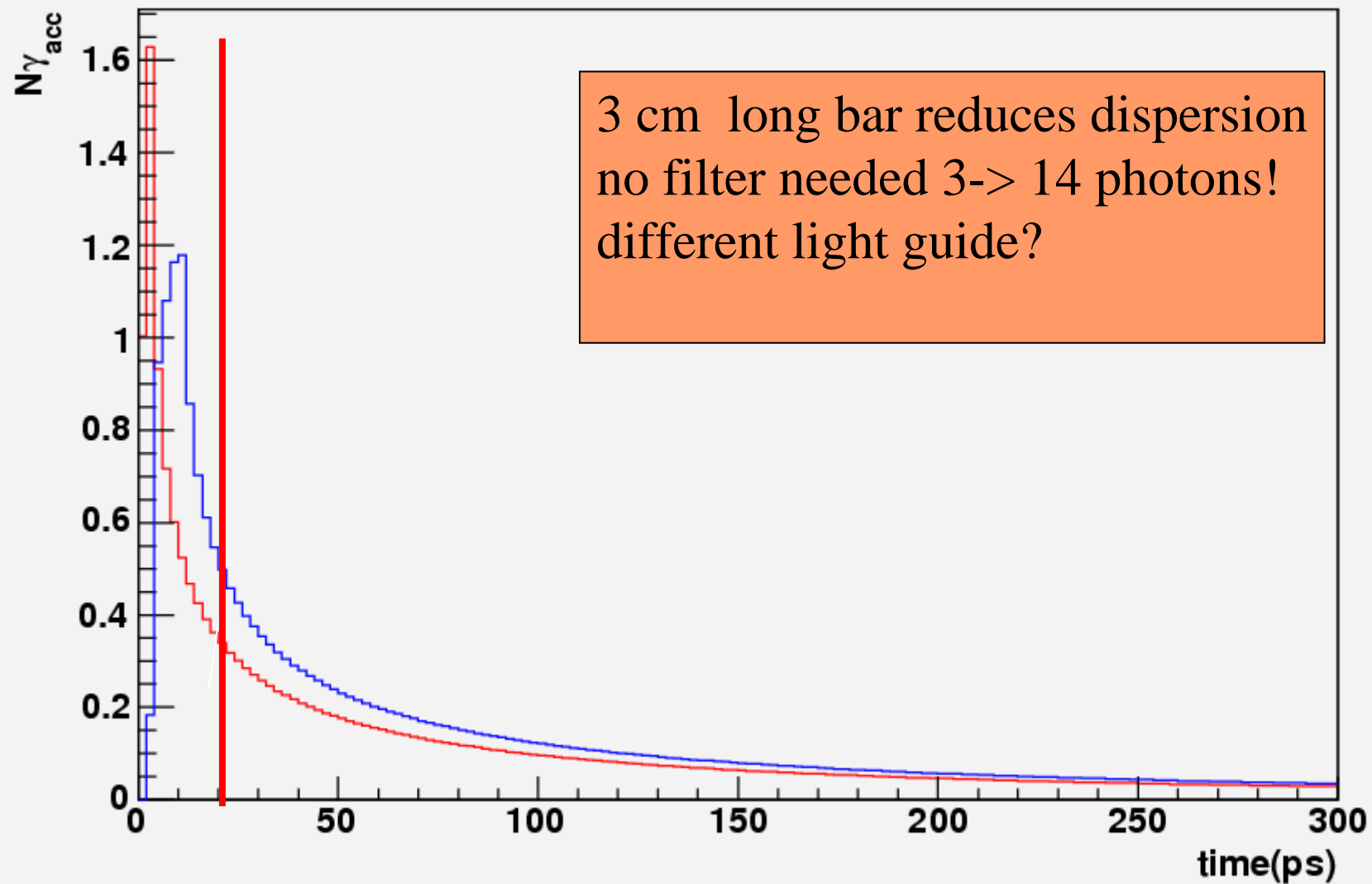

# Fused Silica Purchase

## Specialty Glass Products, Inc:

5. Fused Silica Rod; 6mm $\pm$ .051mm square; 9cm $\pm$ .0254cm long; 6mm x 9cm sides mechanically polished finish, within 1° parallelism and perpendicularity and less than or equal to 1 wave/inch flat; one end mechanically polished finish.

Quantity 8 pieces

Price \$39.00 each

6. Fused Silica Rod; 6mm $\pm$ .051mm square; 9cm $\pm$ .0254cm long; 6mm x 9cm sides mechanically polished finish, within 1° parallelism and perpendicularity and less than or equal to 1 wave/inch flat; both ends mechanically polished finish.

Quantity 24 pieces

Price : \$36.00 each (Had 4 of the bars converted to 16 mini-bars)

## Technical Glass Products, Inc:

I) Fused silica n~1.5

lengths for a set are 90,95,100,105,110,115 mm

a) high transmission over range 180-700 nm

i) 4 sets polished on all faces

***\$2,565.00 per set (GASP)***

# Fused Silica Bars

- 9 cm bars arrived
- mini-bars en route

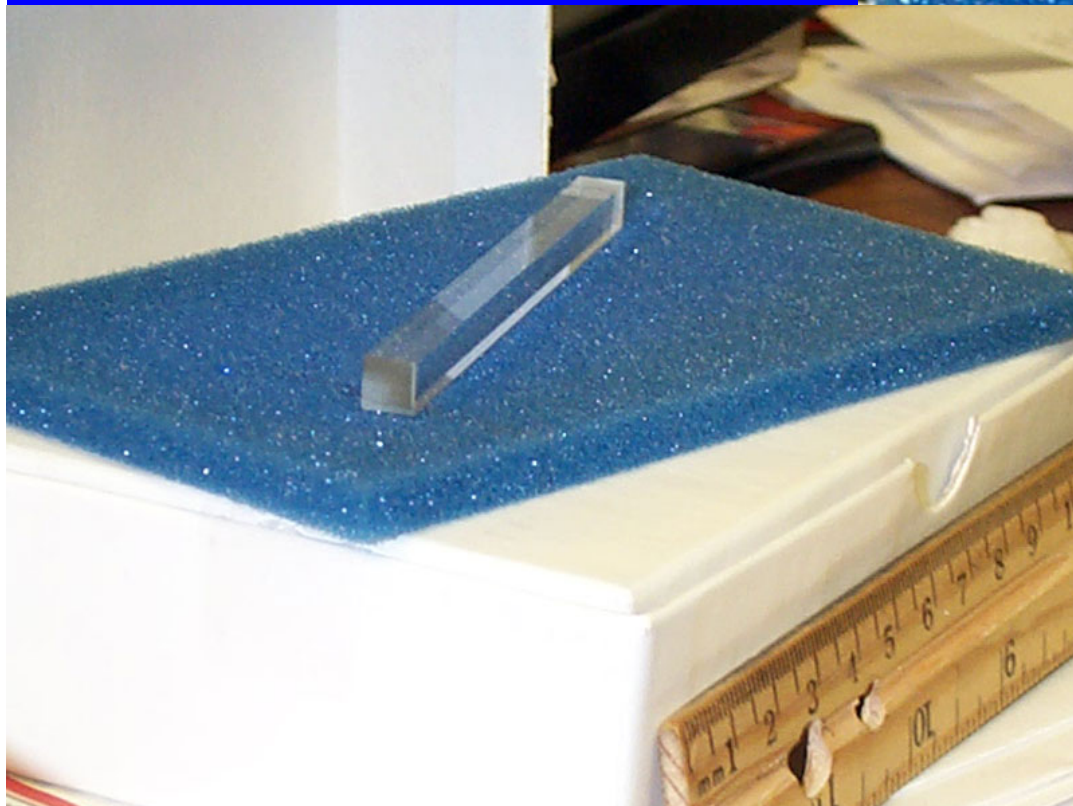

# Test Beam News

- May 5 TB meeting leads to decoupling of FP420 and CMS Pixels, locate a better area downstream of CMS, with more space  $>1\text{m}$ , will allow simultaneous test of Quartic+Gastof, easier integration into CAMAC-based DAQ
- Pedro goes to Fermi for summer May 15, to prepare for TB
- Tentative date July 24-31
- Mike setting up MOU



# TB Preparation

- 1) buy "quartz" (UTA)
- 2) simple frame (UTA)
- 3) air light guides (Alberta)
- 4) readout integration, data analysis preparation (UTA)
- 5) electronics circuit (Alberta/Louvain)
  - i) off shelf nim/camac cfd and tdc for early test beam July 24
  - ii) new improved circuit for Aug./Sep.
- 6) Test beam preparation (FNAL, UTA, Alberta)

manpower: pedro+? Louvain (3)  
Helsinki?, Saclay? other?
- 7) Analysis all

# Test Beam Frame

side view

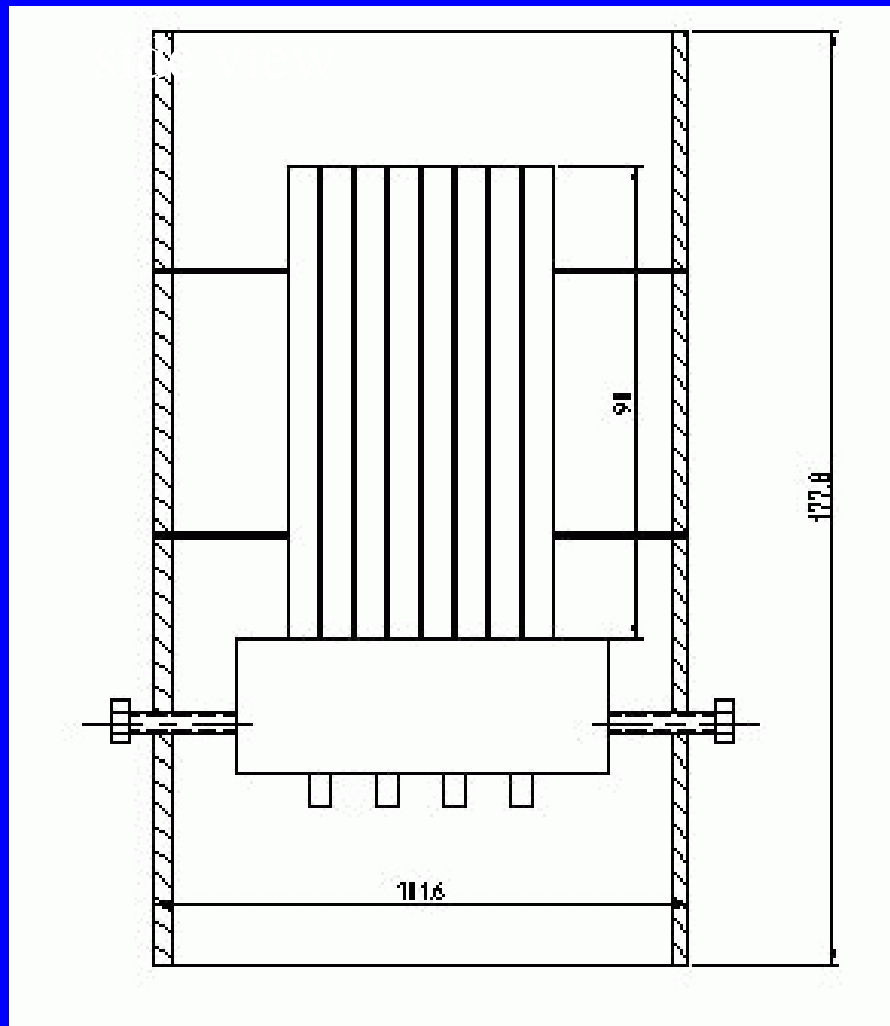

cross section

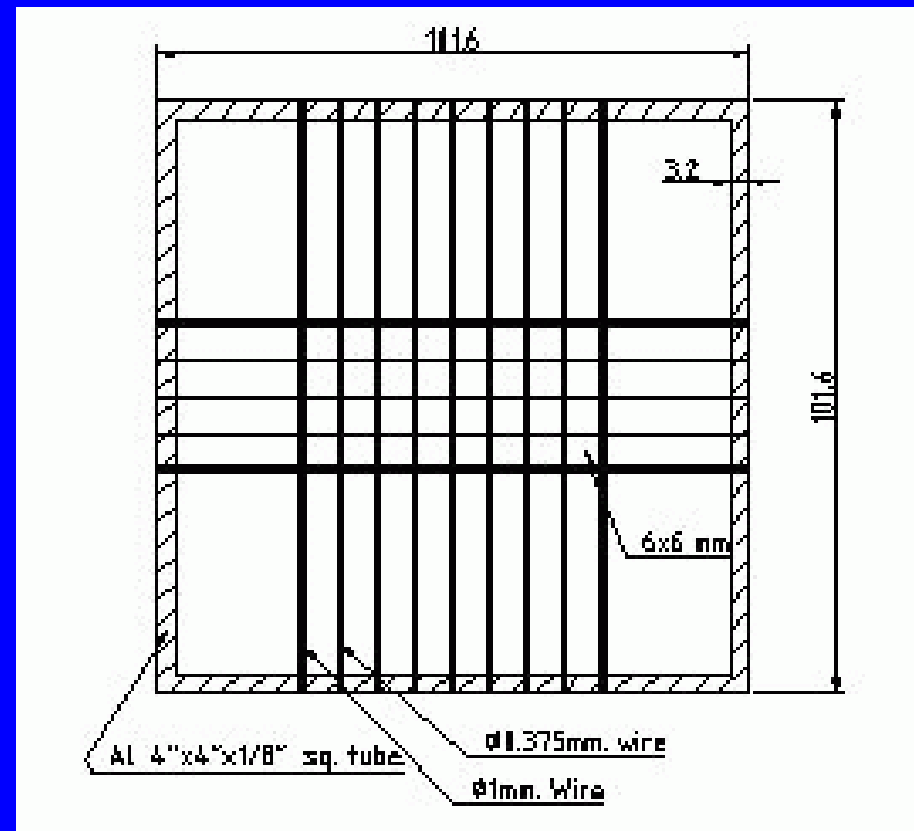

wires to hold bars allows reconfig 18

# Test Beam Electronics

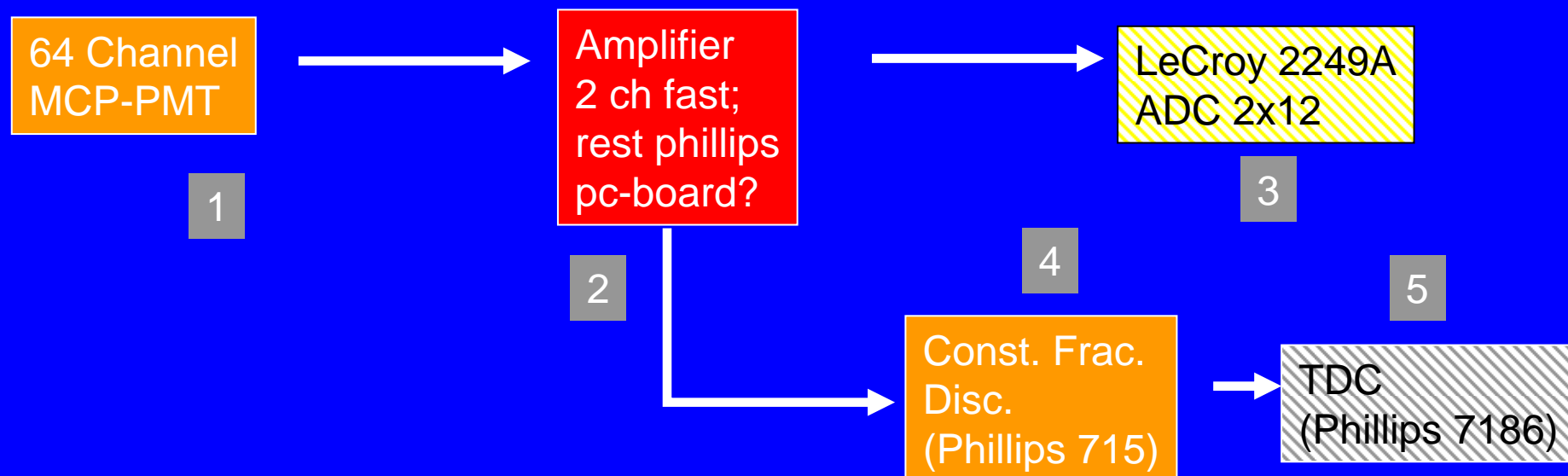

- 1) -3k HV, 4 channels needed
- 2) get a couple expensive single channel amps (ORTEC 9306) in addition to work on PC board
- 3) Plan to get a couple expensive single channel amps (Ortec 9306) in addition to Louvain work on PC board
- 4) Phillips 715 CFD is suitable, are there 4 available at Fermi (5 channel each)?, will be on board for final setup (Alberta)
- 5) In process of purchasing Phillips 7186 16 channel TDC (\$3k) , 25 psec least bit, use HPTDC for final setup.

# Pinfold on Air Light Guides

- The problem we are facing with the air light guide and Winston Cones is exactly the same problem that we have faced with LUCID, where we have a Cerenkov tube array (essentially an array of air light guides) plus a WC collection system. We are tooled up to optimize the air-light guide WC design. The problem is a 3-D one if you want to optimize the design. We have the GEANT4 software to do this.
- We plan to make the air light guide matrix using a 3-D plotter. We will line the resulting matrix with aluminized Mylar to make the air light guides. We can program the WC design to fit on the end of the air light guides and "print" the new detector.
- Although we can line the plastic square light guides with aluminized mylar it would be hard to do this with a WC since it has a 3-D "parabolic-like" surface. Our plan would be to vacuum deposit aluminium on the inner surface of the WC. We already have some experience with this as part of the LUCID project.

# Albrow Sketch of Mini-bar Solution

dimensions in mm,  
not to scale

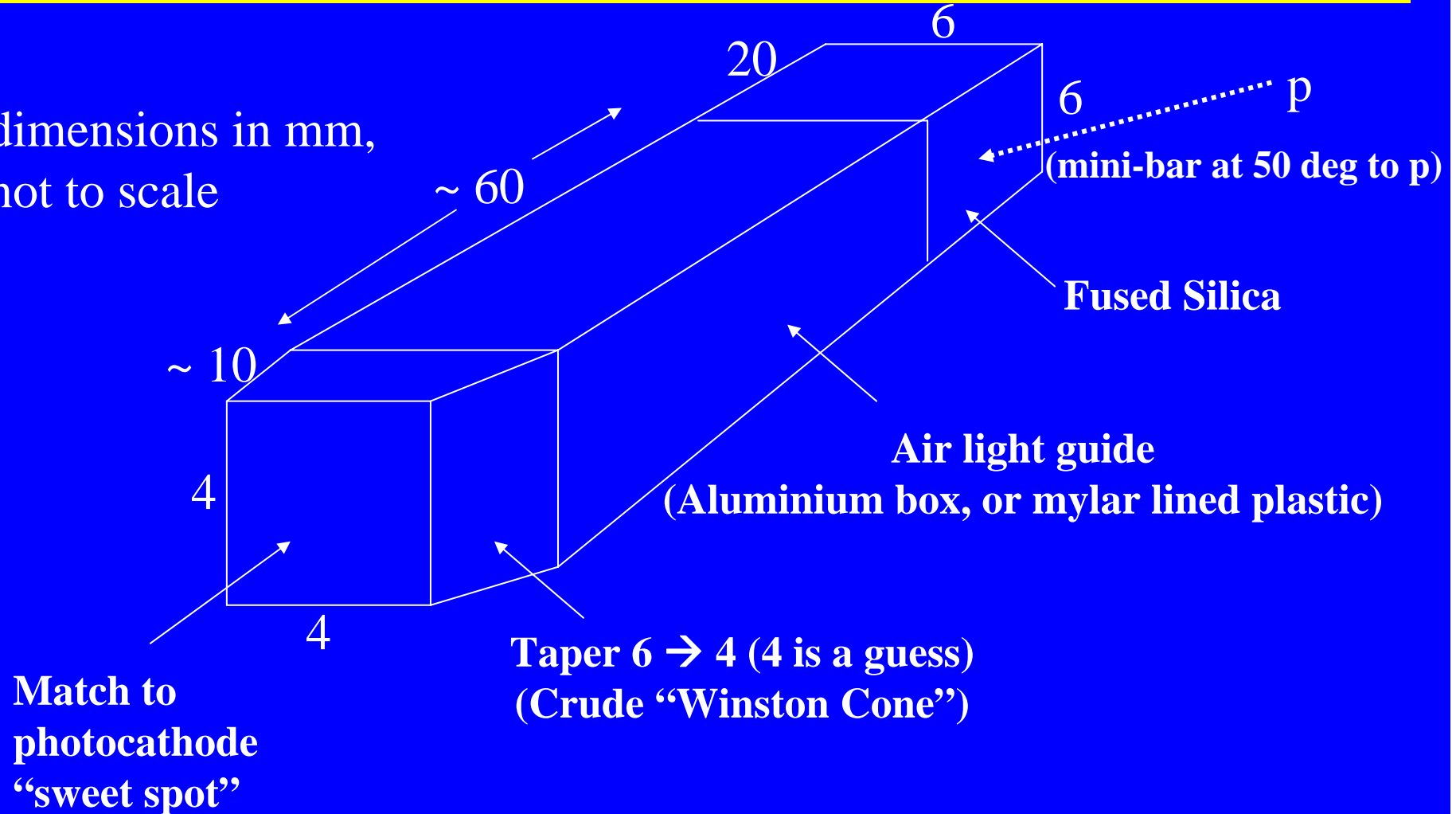

Simulations in progress

# Conclusions

**Fast TOF is a critical part of FP420**

**So how do we achieve a resolution of 10-20ps for the full detector system?**

- 1. 20 ps actual detector seems feasible.**
- 2. 30 ps in the MCP-PMT for a single photon seems feasible.**
- 3. 15 ps electronics seems feasible.**

**Therefore need multiple photon statistics (for each fused silica bar) as well as multiple measurements along the track. (have several bars).**

**Mini-bar solution looks promising**

**Plan to test baseline detector in Fermi test beam this summer**

**Schedule tight**

**Test beam manpower is an issue**

**Funding is less of an issue than it used to be!**