

LHC BEAM DUMPING SYSTEM STATUS AND READINESS FOR LHC RUN II

N. Magnin, M. G. Atanasov, J. Borburgh, C. Boucly, E. Carlier, S. Gabourin, B. Goddard, V Senaj, J. Uythoven, N. Voumard, W. Weterings, CERN, Geneva, Switzerland

Abstract

The hardware status of the LHC Beam Dumping System (LBDS) after the many announced system improvements performed during Long Shutdown 1 (LS1) will be presented. The latest estimates of expected availability and reliability of the LBDS after LS1 will be summarized. The readiness of LBDS for LHC start-up, including the progress of the reliability runs, as well as the commissioning plan will be discussed. A list of the tests with beam required to validate the system after LS1 will be proposed.

INTRODUCTION

During past operation of the LHC, all requested beam dumps were executed correctly and no damage to the accelerator related to the LHC Beam Dumping System (LBDS) occurred [1, 2]. But the repairs to the interconnections of the LHC main dipoles, taking place during the present Long Shutdown 1 (LS1), will allow increasing the beam energy of the LHC from 4.0 TeV to approximately 6.5 TeV from 2015 onwards. This increased energy means higher operational voltages of the LBDS generators and could have a negative effect on the operational availability and safety. Modifications applied to the LBDS, with the aim of maintaining the good results mentioned above, are detailed in the following sections along with the re-commissioning plan to assess the good shape of the system after the many upgrades performed.

STATUS OF UPGRADES PLANNED FOR LS1

Addition of MKBV E&F kicker magnets

Two vertical dilution magnet (MKBV) tanks were not installed for LHC Run 1 in a manner to spread the costs as well as the preparation and installation time, the vertical dilution being strong enough with four tanks per beam for the operation limited to 4 TeV.

During LS1 the remaining two vertical dilution magnets and their high-voltage (HV) generators were installed, so we will have the nominal dilution for LHC Run 2.

All the dilution kicker magnets (MKB) tanks are now being slowly conditioned up to their nominal current.

Vacuum reading problems

During LHC Run 1, a lot of problems with the reading of MKB tanks vacuum occurred, so we had to mask the

analog interlocks during almost the whole run. Vacuum team is taking this problem seriously: MKB vacuum gauges were replaced, and then investigation for regular vacuum spikes problem was started. The problem seems to be a real vacuum spike and not a control noise issue. As the problem is not visible anymore during LS1, investigations will have to continue at LHC startup, if the problem reappears.

TE-ABT anyway made the decision to definitively remove the redundant analog interlocks, and so to rely only on the digital interlocks from the vacuum systems, as it was initially planned.

MKD HV generator FHCT switch renovation

The HV generators, that power the extraction (MKD) and the dilution (MKB) kicker magnets, use HV Fast High Current Thyristors (FHCT), semiconductor switches assembled in stacks of ten to sustain the high voltage.

Before the start of LS1 was discovered a problem of electrostatic discharge on the two switches installed inside each MKD HV generator. This electrostatic discharge regularly yields to a self triggering of the switch, which would result into asynchronous beam dump. The operation of the LBDS was therefore limited to 5 TeV.

The adopted solutions consisted in the use of new materials with increased radius for insulating pieces, and the insertion of new insulators between every FHCT of the stack and the return current rods [3].

Moreover, these switches are sensitive to Single Event Burnout (SEB), due to the presence of high energy hadrons (HEH) leaking from the tunnel into the service galleries. A SEB could also provoke a self-triggering of the switch, and so could result in an asynchronous beam dump.

After several measurements of SEB cross-sections of the two FHCT families used in operation were made, a significant sensitivity difference of a factor larger than 50 was observed, and the family of switch the most sensitive to radiations was replaced during LS1 [3]. This should reduce the probability of a SEB-related dump to less than one per year (for an HEH fluence of 10^5 HEH/cm²/year).

The huge work for the renovation of the 80 sacks in operation already started during LHC Run 1, and one or two generators were exchanged during every technical stop. The work was finished during the first months of LS1.

Increase of PTU voltage

Modifications were made to the Power Trigger Units (PTU) that trigger the FHCT switches, with the aim of

increasing the trigger current, as well as reducing the SEB probability of the PTU HV switches [4]. The PTU HV power supply was upgraded from 3 kV to 4 kV, and the PTU HV switches were replaced accordingly.

During Run 1, the use of two FHCT families and the low trigger current forced us to use a variable PTU voltage vs. energy specific to each generator. This resulted in a long switch synchronisation procedure, and a complicated management of the PTU voltage reference tables. The tests with an increased PTU voltage and a single FHCT family resulted in a lower dispersion of switching times, which would make possible the use of a unique constant PTU voltage of 3500V for all generators.

The 80 PTU crates in operation have been reworked during the first months of LS1 and are now operational.

TCDQ – Absorber reinforcement

At the beginning of LS1, the previously installed TCDQ systems were removed from the LHC. Subsequently, additional space was made available upstream of the original location for the installation of the upgraded TCDQ absorbers [5]. The new TCDQ was extended from 6 m to 9 m, and the absorber material changed for a sandwich of graphite and Carbon Fibre reinforced Carbon (CFC) to be compatible with future HL-LHC beams. A 10.6 m movable girder was installed, upon which are located the three vacuum vessels that contains the absorbing elements. New ‘large displacement’ vacuum bellows connect each movable TCDQ system to the LHC beam pipe.

At present, both TCDQs (for beam 1 and beam 2) are installed, aligned and under vacuum.

TCDQ – Control consolidation

As a result of the study held in 2009 [6], that identified a common mode failure of the PLC CPU which provides both position control and supervision, the TCDQ control system will be consolidated. The main change is the dissociation of the Motor Drive and Control (MDC) and Position Readout and Survey (PRS) modules into two separate functional entities, each one based on an independent PLC, see Figure 1.

The LVDTs used for the position measurements were replaced by potentiometers. Two potentiometers were installed above each other, attached to the girder at the same longitudinal position at the entrance and exit of the absorber blocks, to avoid the introduction of errors between the read-outs. These potentiometers are used for the remote displacement system (one for regulation and the second one for the verification).

The hardware is ready, and is being installed in the LHC. The remote displacement tests are planned later in 2014.

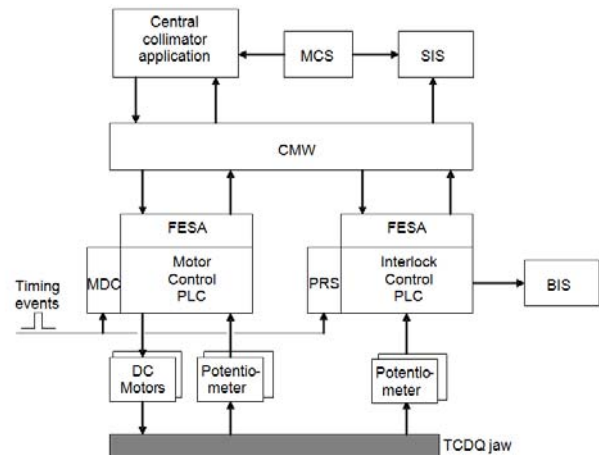

Figure 1: New TCDQ software architecture: separation of MDC & PRS functions.

TCDQ – Beam Energy Tracking System

To add redundancy to the PRS, a Beam Energy Tracking System (BETS) [7] is being implemented for the surveillance of the correct position of the TCDQ jaw w.r.t. the beam energy. The jaw positions are measured thanks to two potentiometers installed on each side of the girder.

This BETS will be connected to the LHC Beam Interlock System as an additional maskable channel and will request a beam dump in the case an incorrect TCDQ position is detected.

Shielding of cable ducts between UA and RA

Now only the cable ducts in front of TCDQ are filled with iron rods. During LS1, all the cable ducts between UA and RA in front of MKD and TCDQ systems will be filled with iron rods to diminish then radiation level in UA, mainly due to TCDQ scattering.

This work has not been planned yet.

Improvement of Power Distribution Architecture

Following the LBDS powering review held in 2012 [8], lots of improvements will be performed on the LBDS power distribution. The LBDS was directly connected to a second UPS located in US65, and every crate Power Supply Unit (PSU) is powered through an individual circuit breaker. The monitoring of the state of all the redundant PSUs of LBDS crates is now performed, and the Software Interlock System (SIS) will request a dump in case a failure is detected in a PSU.

A Power-Cut test is still to be performed, with F3 and F4 circuits OFF simultaneously. The test is not planned yet. To be noted that the same test was already performed successfully in September 2013, after LHC Run 1.

TSU v3 Development

Following the operational experience gained during Run 1 of the LHC, the external review of the Trigger Synchronisation Unit (TSU) card design performed in 2010 [9], the internal review of LBDS Powering

(2012) [8] and the identification of a possible common mode failure scenario at the level of the distribution of the +12V inside the unique crate containing the two TSU cards, a new design of the TSU card has been carried out, and the new hardware will be installed within the LBDS during LS1.

In order to avoid the +12V common mode failure, the two TSU cards are now deployed over two separate VME crates. A third VME crate will contain the shared RF and BI hardware. A surveillance of all internal voltages was added to the TSU card itself, hence the redundant card will trigger in case the first one loses one of its power supplies. Additionally, an internal continuous surveillance of the CRC of all the TSU programmable logic circuits (FPGA) has been implemented. In case of a Single Event Upset (SEU) corruption of one of the programmable circuits, an incorrect CRC will be detected and a dump request will be issued to the redundant TSU through a dedicated channel. The on-board diagnosis functionalities have been significantly improved, such as the surveillance of the output current of the synchronous beam dump trigger signals, and many additional TSU internal signals will be acquired and analysed by the Internal Post Operational Check (IPOC) system [10], such as all the redundant dump requests from all the various clients.

The hardware prototypes were validated and a production of twelve cards was done.

The firmware development is still in progress. It is foreseen to have two main development steps: A first one limited to porting the TSU v2 firmware on the TSU v3 hardware, the second step would support the new TSU v3 hardware capabilities and diagnosis features.

If the first firmware is not operational in July, we might have to fall back to the TSU v2 version, but deployed over two crates anyway, which implies the development of a new VME backplane to interconnect the two TSU cards.

Direct connection from the BIS to the LBDS Retrigger-lines

It was noted that the beam dumping system is very sensitive to any unidentified failure mode of the Trigger Synchronisation and Distribution System (TSDS) [11]. In case of failure of the TSU, and despite the large redundancy within it, any external beam dump request of the Beam Interlock System (BIS) would not be executed. To reduce this sensitivity, a direct link is established between the BIS and re-triggering system of the LBDS [12]. The new link between BIS and LBDS consists of an electronic board (CIBDS) that follows the same principle as the board mounted on the TSU (CIBO): It is included in the optical loops, and generates a dump request when it fails to detect the Beam Permit.

In normal operation, the dump trigger is issued by the TSU synchronously with the beam abort gap. To cover a possible failure of this synchronous trigger, an asynchronous dump request is also systematically generated by the TSU. As up to 90 μ s (one beam revolution) can be necessary to trigger a synchronous

dump, the asynchronous dump request is delayed by 200 μ s using a Trigger Delay Unit (TDU). The CIBDS generates an additional asynchronous dump request, delayed by 250 μ s, using a TDU of 250 μ s (TDU250).

The 2 CIBDS cards, along with the 4 TDU250, were installed in the LHC and connected respectively to the BIS and the LBDS re-trigger lines.

Software upgrades

During LS1, BE/CO performs major upgrades to the control software systems. The most important change is the new Front-End Software Architecture v3 (FESA3), using a new communication layer Remote Device Access v3 (RDA3). As a consequence we have to adapt most of our control software to these new frameworks. The development of FESA3 and RDA3 was being delayed a lot, so our migrations are not going as fast as expected.

The only fully migrated system in operation at LBDS is the State Control and Surveillance System [13]. Some systems are under test in the laboratory, such as the TSU-VME diagnosis and the IPOC system. But the migration of the BETS and the development of the new control system of the TCDQ MDS&PRS, are still to be done.

Moreover the addition of MKBV E&F and the increase of operational energy above 5 TeV imply numerous changes in the PLC software, the LBDS Analysis & Calibration tools [2], and the eXternal Post Operation Check (XPOC) analysis system [14].

All software upgrades are planned to be finished by the end of summer.

AVAILABILITY & SAFETY ESTIMATES

LBDS Safety & Availability Study Projects

Before the start of LHC, a Ph.D. thesis was conducted at CERN on the LBDS dependability analysis [15]. This study predicted the LBDS to be SIL 4, and a number of 8 ± 2 false beam dumps and 2 asynchronous beam dumps per year. It was based on Time-To-Failure (TTF) data from manufacturer or military handbooks.

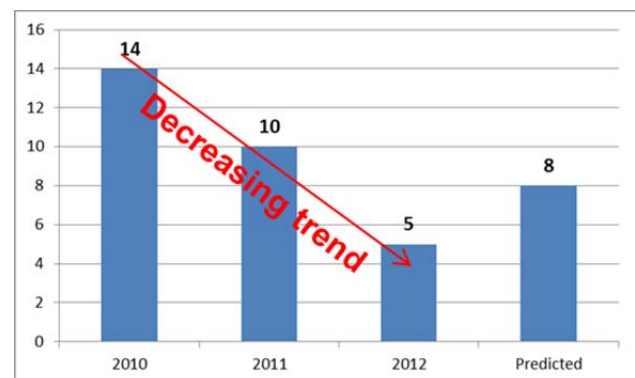

Figure 2 Number of false beam dumps observed vs. predicted

After LHC Run 1, a mandate was given to the same expert to update the model, based on operational fault statistics [16]. 139 failure events, of which 90 were internal to LBDS, were collected from LHC-OP and TE-ABT logbooks for the period 2010 – 2012. They were then classified and identified to a failure mode.

The updated LBDS safety model predicts a **SIL3** safety level at least, which is more conservative than predicted in 2006, because of the contribution of new failure modes, but nevertheless still acceptable. Predicted rate of asynchronous and false beam dump are not changed. All statistics, including availability and safety, show a positive trend, which attests an improvement in operation, see Figure 2.

Safety Margin & Safety Gauge

The absence of any major catastrophic event is a necessary but not sufficient condition to assess that the LBDS meets SIL3 at least. A new approach consisting of the computation of a safety margin value after every beam dump is proposed: How far from a single point of failure were we during the last dump execution? A new metric, based on the reliability model, must be defined to estimate the distance to a single point of failure after every dump.

This new metric could also help to balance safety and availability: Is the system protected or over-protected?

In case of nominal beam dump, the system is expected to be fully available or in an acceptable degraded state.

In case of false beam dump, the internal dump must be justified so the safety margin is expected about to be eroded, otherwise the LBDS is certainly overprotected.

It was suggested that the quantification of the safety margins is performed after every beam dump, and displayed using the safety gauge on LBDS Fixed Display, see shown on Figure 3. This would give system experts and EIC valuable information to take decisions on the LHC operational conditions to accept.



Direct Connection

from BIS to LBDS Retrigger-Lines

A detailed reliability analysis of the CIBDS card and the TDU250 box was performed in order to ensure the LHC safety increase, without significantly reducing its availability [17].

The specification was to not add more than 1 asynchronous dump per beam over 10 years, and no more than two synchronous dumps per beam per year.

The study predicts about 0.025 asynchronous dump for both beams over 10 years and 0.01 false synchronous dump for both beams per year. So the impact of the new direct connection from BIS to LBDS Retrigger-Lines on LHC safety and availability is negligible.

FIRST RELIABILITY RUN RESULTS

Spontaneous Triggering of MKD HV Generators

After the MKD HV generator FHCT switch renovation discussed above, we started the first LBDS reliability run with the aim of validating their sustaining to a voltage corresponding to 6.5 TeV for long periods (> 8h).

We discovered that some generators were still experiencing erratic triggering: 2 generators on LBDS beam 1 (08.2013) and 6 on LBDS beam2 (11.2013).

After month of investigations, we found a workaround consisting of the addition of resistors on the trigger path of FHCT stacks, reducing their sensibility to electrostatic discharges.

One source for the electrostatic discharge was traced back to be insulating tubes in the upper part of the HV generator that get charged slowly due to their geometry and surface properties, and eventually discharges through the top FHCT A-G capacitance.

A new production of insulating tubes was launched, and 20% of the tube will be tested in laboratory before their installation into all LBDS generators, planned for end of July.

We will continue to explore the limits of electrostatic discharges due to the geometry of insulating parts using a 'dummy' generator (where all sensitive electronic parts are remove), operated under a much higher voltage to increase the rate of spike events.

MKB Conditioning

The conditioning of MKB magnets has started. MKB Beam 2 is conditioned up to 7.1 TeV. The vacuum is in good shape (< 4e-7 mbar). MKB Beam 1 recovered well from aluminum foil pollution, and is presently at 6.6 TeV, also to be conditioned up to 7.1 TeV.

LBDS is ready for operation above 6.5 TeV during upcoming dry runs.

FIRST DRY RUN RESULTS

LBDS Armed in REMOTE

The LBDS was configured for operation in REMOTE: The local BIS loops were installed at LHC Point 6, the BETS was connected to a signal generator to simulate the LHC bending magnet currents (BETS-Simulator), and the Beam Revolution Frequency (BRF) was generated locally using a timing card.

The LBDS was successfully armed at 450 GeV. As the MKBs were not yet conditioned, we could not go above.

After updating the LHC sequencer logic, we successfully controlled the LBDS remotely, and executed arm & dump sequence in loop.

The LBDS will be ready for remote dry runs, as soon as the MKBs conditioning will be finished.

Direct Connection from BIS to LBDS Retrigger-Lines

The CIBDS cards were installed at LBDS, along with their TDU250 connected to the retrigger lines between the MKDs and MKBs.

An Internal Post Operation Check (IPOC) system acquires the retrigger pulse from the BIS on the retrigger lines after every dump, and will assess of its presence.

The first measures of this pulse showed that it is attenuated a lot by passing through the 15 MKD retrigger boxes, and fall from 24V at the output of TDU250 to less than 5V at the input of the IPOC. But this level is enough to be properly detected by the digital acquisition cards of the IPOC system, as Figure 4 shows..

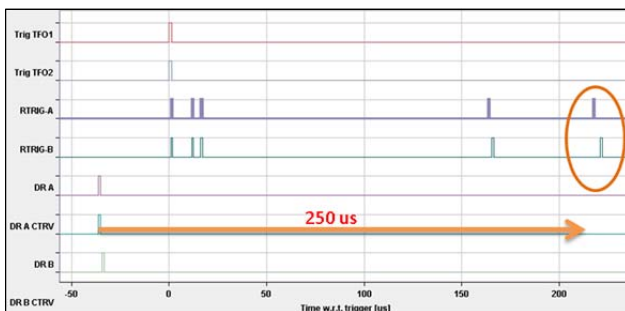

Figure 4: BIS-Retrigger pulses captured by the IPOC system, 250 us after the dump request from the BIS.

We verified that, despite their low level, the pulses from TDU250 successfully trigger an asynchronous beam dump, thanks to the domino effect. This attenuation problem has to be further investigated.

UPDATED PLANNING

Six weeks of tests operated from the Central Control Room will start next week, with the BETS-Simulator and a local BIS loop, to test the new link between the BIS loop and re-triggering system, and the stability of the HV generators during many ramps and dumps.

Then 4 weeks of consolidation work on the LBDS generators are planned, to exchange all the HV insulating tubes and revalidate the generators afterward. The new TSU cards v3 will be installed in the LBDS during this period.

The LBDS will be switched to REMOTE again, for a period of minimum 4 weeks, to test the new TSU v3 cards, the HV holding of the generators for long periods, and the many renovated software components. When the local BIS loops will have to be removed, at a date to be defined by OP and MPE, we will continue with

reliability tests in LOCAL, to validate further more the system, until the beginning of the first sector test, planned for November 2014. To be noted that we would like to keep LBDS in REMOTE with the LOCAL BIS loops as long as possible.

COMMISSIONING

Considering the important changes being performed on the LBDS described above, a complete re-commissioning of the system is mandatory. In addition to the updated Machine Protection Procedures for LBDS [18, 19], the requested tests, with and without beam, described below should be performed.

Commissioning without beam

We request 2 days with the LBDS armed in REMOTE, with the BIS loops closed, to re-validate the hardware and all the software layers, re-check the arming sequences and the Injection Permit signals, test the Inject and Dump test modes, etc.

Commissioning with beam

We will need some time of LHC with pilot beams to re-synchronise the MKD rising edge with the abort gap of circulating beam, and the Beam Abort Gap Keeper (BAGK) with the injected beam, by adjusting respectively the TRIGGER and the BAGK delays on the TSU cards.

A scan of the MKD rising edge is requested as well, as it was never done before. The procedure for such a measurement is still to be approved. One complete run will be needed.

Also the BLMDD client of the TSU cards has to be activated. The procedure does not exist, and has to be defined and approved.

CONCLUSION

Although the LHC beam dumping system performed as expected during the LHC Run 1, an important list of system improvements are being implemented during the present long shutdown.

Unforeseen complicated problems of spontaneous triggering of high voltage generators were encountered, and long investigations were needed to identify a possible source. Consequently we are late on the original schedule, but fortunately we foresaw margin.

The LBDS will be in REMOTE, ready for dry runs, after the MKBs conditioning, estimated for next week.

A lot of changes have been performed on LBDS during LS1 so careful re-commissioning is mandatory.

All these modifications should allow the safe operation of the beam dumping system at higher beam energies.

REFERENCES

- [1] The LHC Design Report: "The LHC Main Ring", Vol. 1, CERN, Geneva 2004, CERN-2004-003-V-1

- [2] J. Uythoven, E. Carlier, L. Ducimetière, B. Goddard, V. Kain, N. Magnin, “Beam commissioning and performance characterisation of the LHC beam dump kicker system”, IPAC’10 Kyoto, Japan, May 2010, <http://www.JACoW.org>
- [3] V. Senaj, “MKD & MKB overhaul programme - Partly replacement of FHCT switches,” CERN - EDMS 1163361, 2011.
- [4] V. Senaj, “SEB C-S measurements of power IGBTs” [Online]. Available: <http://indico.cern.ch/getFile.py/access?contribId=5&esId=2&materialId=slides&confId=204593>.
- [5] W. Weterings et al., “Upgrade of the LHC Beam Dumping Protection Elements”, IPAC’12 New Orleans, May 2012, <http://www.JACoW.org> pp.556.
- [6] R. Filippini, “Safety Analysis of the Movable Absorber TCDQ in the LHC Beam Dumping System,” CERN-ATS-2009-004
- [7] N. Voumard et al., “The Beam Energy Tracking System of the LHC Beam Dumping System,” ICALEPCS’05, Geneva, Switzerland, October 2005.
- [8] “Technical review on UPS power distribution of the LHC Beam Dumping System (LBDS),” CERN, 12 June 2012. [Online]. Available: <http://indico.cern.ch/conferenceDisplay.py?confId=195055>.
- [9] STUDIEL, “Reports of TSU technical review,” CERN - EDMS 1105342, 2010.
- [10] N. Magnin et al., “Internal Post Operation Check System for Kicker Magnet Current Waveforms Surveillance,” in ICALEPCS’14, San Francisco, October 6-11 2014.
- [11] A. Antoine et al., “The LHC Beam Dumping System Trigger Synchronisation and Distribution System,” in ICALEPCS’05, Geneva, Switzerland, October 2005.
- [12] S. Gabourin et al., “Implementation of a direct link between LHC beam interlock system and the LHC beam dumping system re-triggering lines”, these proceedings.
- [13] E. Carlier et al., “Commissioning of the Control System for the LHC Beam Dump Kicker System”, ICALEPCS’09, Kobe, October 2009.
- [14] N. Magnin et al., “External Post-Operational Checks for the LHC Beam Dumping System,” in ICALEPCS’11, Grenoble, France, 2011.
- [15] R. Filippini, “Dependability Analysis of a Safety Critical System: the LHC Beam Dumping System at CERN”, CERN-THESIS-2006-054 - Pisa University, 2006.
- [16] R. Filippini, J. Uythoven, “Review of the LBDS Safety and Reliability Analysis in the Light of the Operational Experience during the Period 2010-2012”, CERN-ATS-Note-2013-042 TECH.
- [17] V. Vatansever, “Reliability analysis of the new link between the beam interlock system and the LHC beam dumping system”, Diplomarbeit Uni Stuttgart, IMA2014-ZU-14, 2014. Also CERN-THESIS-2014-042.
- [18] B. Goddard et al., “Beam Dump System Commissioning,” CERN - EDMS 896392, 2009.
- [19] V. Kain, M. Solfaroli, J. Wenninger and M. Zerlauth, “Procedure In Case Of Non-Working Dump Trigger,” CERN - EDMS 1166480, 2012.