

LBDS AND KICKERS AFTER LS1

W. Bartmann, M.J. Barnes, J. Borburgh, C. Bracco, E. Carlier, B. Dehning, L. Ducimetiere, M. Fraser, B. Goddard, S. Grishin, E.B. Holzer, V. Kain, N. Magnin, A. Masi, M. Meddahi, V. Mertens, A. Patsouli, V. Senaj, H. Thiesen, J. Uythoven, N. Voumard, J. Wenninger, C. Zamantzas, M. Zerlauth, CERN, Geneva, Switzerland

Abstract

Modifications of the injection kickers(MKI) during LS1 will be reviewed together with the expected performance for the coming run with respect to heating and UFOs.

The beam dump system has undergone several foreseen upgrades like a new link between the trigger synchronisation unit (TSU) to the beam interlock system, an additional retriggering line in case of TSU failure, a new dump protection absorber (TCDQ) and the installation of an additional vertical dilution kicker (MKBV) tank. Difficulties in holding off the voltage in the beam dump kickers (MKD) generators lead to an improved design of insulators and spacers. Results from the first week of reliability runs at 7 TeV will be shown.

A set of new interlocks for the injection and dump systems has been introduced during LS1 and will be reviewed: transfer line collimators (TCDI) gap control via virtual beta* and injection dump (TDI) gap control, injection septum (MSI) current and TCDQ position linked to the beam energy tracking system (BETS). The strategy for deploying blindable beam loss monitors at injection will be presented.

INJECTION KICKERS AFTER LS1

MKI Heating

Prior to LS1 only 15 out of 24 screen conductors were installed, in the LHC injection kicker magnets (MKIs), to avoid flashovers. The 15 conductors were arranged such that the ferrite is screened and - in order to reduce the flashover probability - the lower part of the chamber close to the high voltage bus bar was left without screen conductors. In this configuration most of the MKI magnets had a power deposition of 70 W/m; a value which - known from operation in 2012 - does not limit injection. However, the MKI8D magnet had a power deposition of 160 W/m which limited injection between high-luminosity fills due to extended waiting times to let the ferrite yoke cool down. The increased heating in the MKI8D originated from twisted conductors. The beam screens of all 8 MKIs have been upgraded during LS1. The outside metallization has been removed from the ceramic tube starting about 20 mm before the open-circuit end of the screen conductors. A conducting metal cylinder with a vacuum gap of 1 – 3 mm to the ceramic tube has been added. These modifications allow all 24 screen conductors to be installed: in addition the predicted maximum electrical field, on the surface of the ceramic tube, with 24 screen conductors installed is 40% less than was the situation for the 15 screen conductors

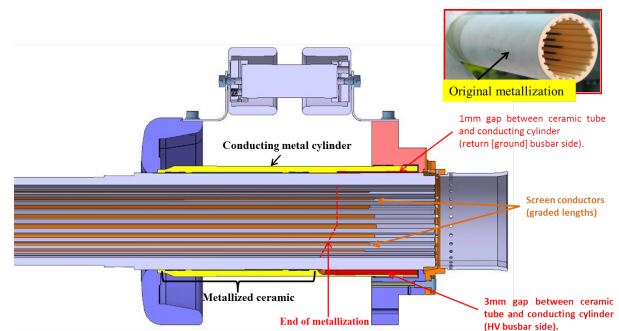

Figure 1: Improved MKI beam screen with 24 graded length conductors and a conducting metal cylinder with a vacuum gap of between 1 to 3 mm to the ceramic tube.

pre-LS1. The 90° twist of the conductor slots, in the old MKI8D, along the length of the ceramic chamber, orientated the 9 screen conductor gap, at the downstream end of the MKI8D, from the high voltage bus bar to the ferrites, and therefore caused a significant increase of heating of the magnet yoke, especially at the downstream end. The newly manufactured ceramic tubes are carefully inspected to ensure that they do not have a twist: however a twist of the conductor slots, with the now installed full complement of 24 screen conductors, would not have a significant effect upon yoke heating. The expected power deposition after LS1 is approximately 50 W/m, thus, heating of the MKI ferrite yoke is not expected to limit injection.

In order to validate the high voltage performance of the MKI magnet with the full complement of screen conductors the magnets have been tested up to 56.4 kV pulse forming network (PFN) voltage (nominal at Point 8 is 51.3 kV): as expected from predictions the flashover performance is even better than for the originally installed screen with 15 conductors. Tests of the beam screen have also been carried out outside the magnet, with background pressure of neutral hydrogen in the range of $1 \cdot 10^{-9}$ to $1 \cdot 10^{-7}$ mbar. The test setup will be modified such that the injected hydrogen gas can be ionized during the tests, to better represent the effect of the beam in the LHC.

MKI UFOs

In view of dust particles creating beam loss (UFOs), improved cleaning of the ceramic tube has given a substantial reduction of dust particles relative to the MKI8D installed during the technical stop 3 (TS), 2012, – which itself had the lowest rate of UFOs at Point 8. During the LS1 upgrades, the ceramic chambers have been flushed with high

pressure dry nitrogen and the dust particles captured in a filter: subsequently the number of dust particles in the filter has been estimated by the CERN material and metrology section (EN-MME-MM). The MKI8D installed during TS3 in 2012 resulted in $390 \pm 47 \cdot 10^6$ particles after flushing and this unit showed low UFO occurrence in beam based measurements; with the new cleaning procedure the number of particles is reduced by another factor of 20 – 40, thus, the occurrence of UFOs in the MKI magnets should be significantly reduced after LS1. It is assumed that the

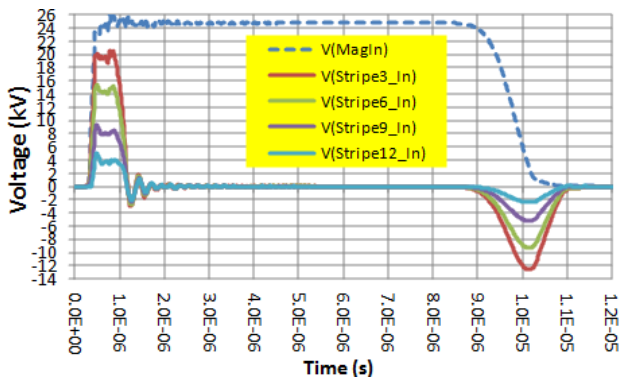

Figure 2: Induced voltage on the screen conductors during MKI pulsing.

installation of the full complement of screen conductors is beneficial also for UFOs. Figure 2 shows the induced voltage on the screen conductors: this occurs during the rise and fall of an MKI field pulse. On the flat top, pre-LS1, electric field could enter at the unscreened part of the chamber close to the high-voltage bus bar (Fig. 3), and potentially detach and accelerate charged dust particles. After LS1 the chamber will be fully screened and resemble a Faraday cage. This should further reduce the possibility of generating UFOs in the MKIs.

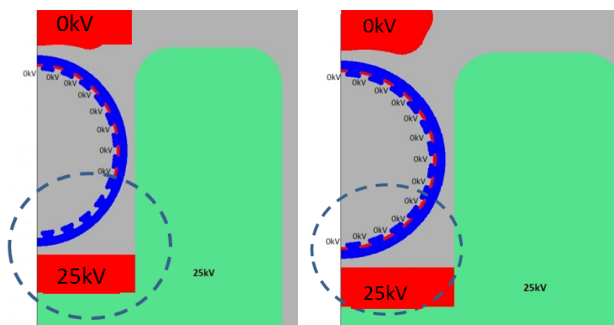

Figure 3: Area where electric field lines can penetrate into the ceramic chamber (left) and fully screened chamber after LS1 (right).

MKI Electron Cloud

The nine additional screen conductors have a high chromium content which conditions well compared to the

ceramic chamber. Together with many additionally NEG-coated parts around the MKI [1] it is expected the the electron cloud level around the MKIs will be reduced. In addition, NEG cartridges have been installed on the MKI interconnects during LS1, and these are expected to limit pressure excursions due to electron cloud. In the LHC a conditioning effect of the MKI ceramic chamber is seen: after installation of the MKI8D unit during run 1, it took 250 h to recover the pre-exchange normalised vacuum pressure. Thus a certain conditioning time has to be taken into account for the machine startup.

LBDS AFTER LS1

TCDS Powering

A powering weakness of the trigger synchronisation and distribution system (TSDS) in the LHC beam dump system (LBDS) was discovered in 2012. A short circuit of the +12V TCDS crate could have prevented any trigger being propagated to the dump kickers and consequently have lead to a case where no dump is triggered although requested. As mitigation the redundant trigger synchronisation units (TSU) with separate powering which were located within a single crate were separated into two independently powered crates, Fig 4. All other systems were relocated into a third VME crate. In case of an internal failure, a synchronous dump from the redundant crate would be triggered. These modifications increase the complexity of the system which might lead to reduced availability but improved safety. There is no degraded running mode of the system foreseen. If any of the redundancy is lost, a dump will be requested and the system be repaired.

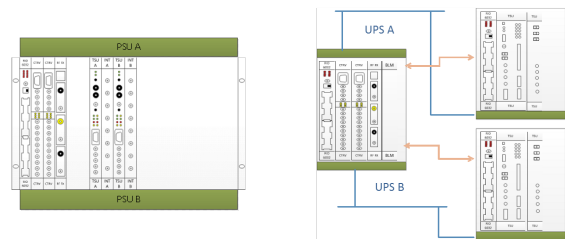

Figure 4: Changed TCDS powering after LS1. Both TSUs are located in separated VME crates with independent powering.

Retriggering Line

The Beam Interlock System (BIS) will generate retrigger pulses $250 \mu\text{s}$ after the initial dump request directly linked to the retrigger line, Fig. 5. In case the TSDS system - for a yet unidentified failure mode - does not send a synchronous trigger, an asynchronous dump will be triggered via the direct BIS link. On a longer time scale of a few 100 ms, an external surveillance was put in place to guarantee a synchronous dump in case the main and uninterruptable power supplies are lost. The functionality of the retriggering line was successfully tested with the local BIS over several weeks.

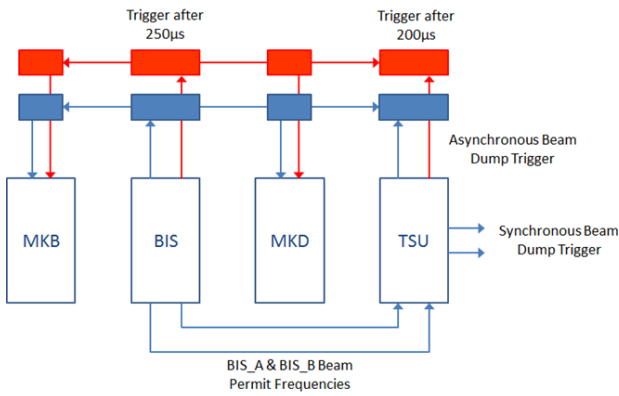

Figure 5: Direct link between BIS and retriggering line [2].

TCDQ Upgrade

In order to be compatible with HL-LHC beams at 7 TeV, the TCDQ absorber was upgraded with an additional tank increasing the jaw length from 6 to 9 m, Fig 8. The graphite absorbers with the density 1.8 g/cm^3 were replaced by a sandwich of graphite (1.83 g/cm^3) and Carbon Fiber reinforced Carbon (CFC) of 1.75 and 1.4 g/cm^3 , Figures 6 and 8. Collimators of this length require an angular alignment to assure their protection functionality. During run 1 it was not possible to correctly measure the angle of the TCDQ jaw with respect to the beam since no tilt possibility was mechanically foreseen. After the upgrade in LS1 an angular movement of $\pm 1 \text{ mrad}$ will be allowed.

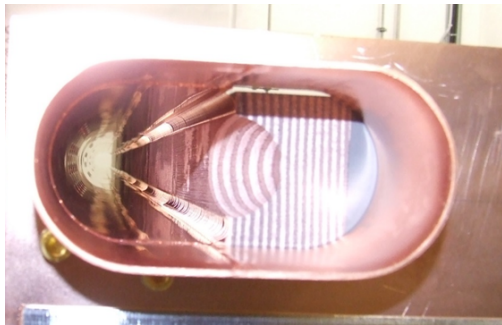

Figure 6: The sandwich structure of the TCDQ jaw and the beam screen. The left part of the jaw close to the beam is made of CFC, while further away from the beam the graphite in dark can be seen.

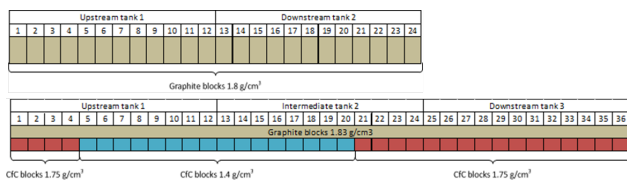

Figure 7: Before (top) and after (bottom) LS1 TCDQ with changed material composition.

The TCDQ electronics was upgraded as well to mitigate

a potential common mode failure of position control and its readout which were implemented in a single PLC. This PLC was placed close to the TCDQ and thus prone to radiation issues. With the upgrade, the two functionalities were split into two separate PLCs which were placed in different locations [3]. The LVDT measurement was replaced by potentiometers and an additional interlock was added on the jaw position via the Beam Energy Tracking System (BETS) system. This interlock accepts a position tolerance of $\pm 0.35\sigma$ and is redundant with the existing collimator motor position interlock with the tolerance of $\pm 0.25\sigma$.

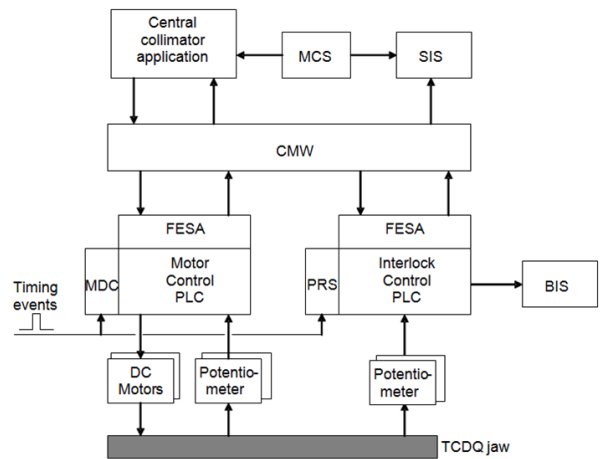

Figure 8: Upgraded TCDQ electronics with position control and readout in separate PLCs [3].

Final Dilution Kicker Installation

One tank with two magnets of the vertical dilution kickers (MKBV) was outstanding to be installed due to cost spreading. The installation has taken place during LS1. Figures 9 and 10 show the dilution shape on the dump screen BTVDD before and after LS1, respectively. The images are results of tracking studies with real machine currents in 2012 and 2014.

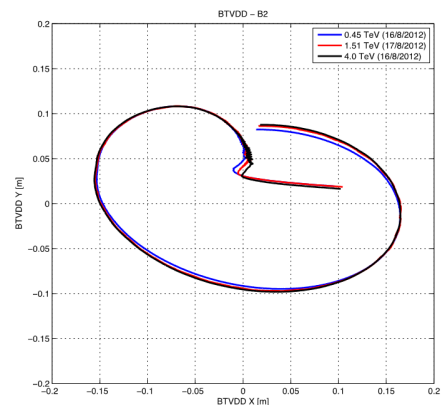

Figure 9: Beam dilution on the dump screen before LS1. Courtesy M. Fraser.

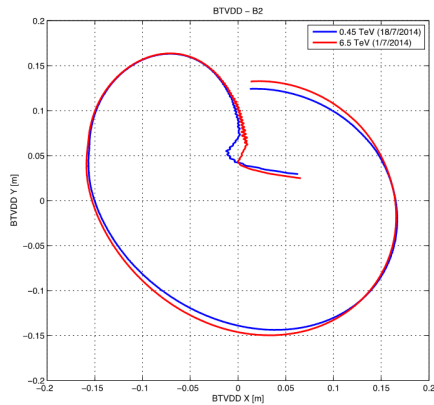

Figure 10: Beam dilution on the dump screen after LS1. Courtesy M. Fraser.

Dump kicker generators

When the dump kicker (MKD) generators were tested up to nominal energy of 7 TeV, electrostatic discharge on the semiconductor switches caused spontaneous self triggering at around 6 TeV. For run 1 the system was therefore limited to 5 TeV. During LS1 high-voltage insulators have been added between the return current Plexiglas isolated rods and the Gate-turn-off thyristor (GTO) high-voltage deflectors, Fig. 11. Up to LS1 two GTO brands were in use.



Figure 11: GTO stacks before LS1 (left) and after LS1 (right) with additional high-voltage insulation.

Measurements of Single Event Burnout lead to the choice of using a single brand from run 2 onwards.

Reliability Run

The aim of the LBDS reliability run is to get statistics for the self-trigger probability of the system. A self trigger of the system would lead to a beam dump where the MKDs fire asynchronously. During this run the voltage discharge problem was detected and mitigated. Since August all measures are in place and the system was until now successfully cycled up to 7.1 TeV, Fig. 12. The reliability run shall be extended until the end of the year which means continuous running of the LBDS.

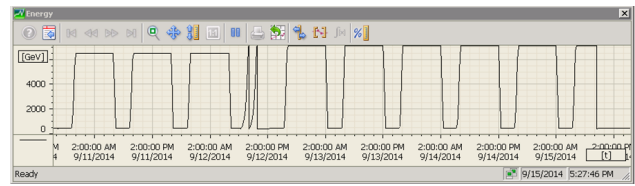

Figure 12: Cycling of the MKD generators up to 7 TeV without self triggers.

NEW INTERLOCKS

Two new interlocks for the injection septum current and the injection dump gap were put in place during LS1, an additional interlock on the gap of the transfer line collimators (TCDIs) will be put in place in the following weeks.

TDI Gap Interlock

During the LHC Run 1 the TDI jaws suffered from elastic deformations due to beam induced heating. The jaw position measurement with linear variable differential transformers (LVDT) was compromised because of the flexible junction between jaw and its mount, Fig. 13. This caused reduced machine availability due to the interlocked tight TDI jaw position tolerances. The criticality of the TDI as

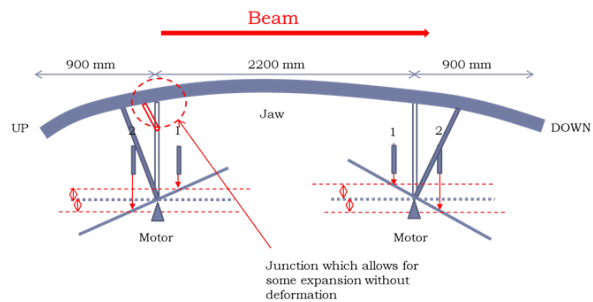

Figure 13: Deformation of the TDI jaw due to beam induced heating. Courtesy C. Bracco.

injection protection element gave rise to add a redundant measurement of the gap between the jaws based on interferometry, Fig. 14. The angular acceptance of the interferometric system is increased by using reflecting tubes instead of mirrors. Also the position measurement shall be kept at all times, from beam position to parking with all possible jaw angles to avoid a re-initialisation of the position. All elements have undergone radiation tests up to 10 MGy. The feedthroughs will be tested for vacuum tightness on a spare for a duration of 6 months. The spare TDI should be ready for installation in the end of year stop 2015/2016. As a difference compared to Run 1, this gap measurement will be connected to the Beam Energy Tracking System (BETS). The BETS will allow for 3 positions:

- *Injection:* 10 mm gap for normal injection operation; the interlock is triggered only if the gap is outside the tolerance or an BETS internal failure occurs.

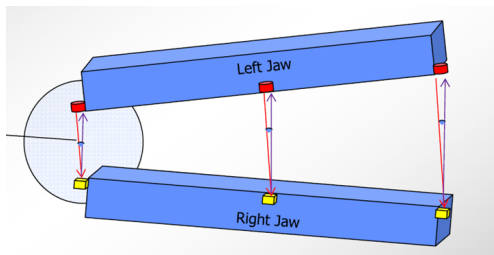

Figure 14: Position of interferometric sensors on the TDI jaw. Courtesy A. Masi.

- *Dump*: In case the TDI is positioned such that the injected beam is stopped, the BETS will be put on a maskable input to allow for the setup of injection system and the TDI itself.
- *Parking*: After injection the TDI is retracted to its parking position of ± 50 mm to reduce the impedance, beam induced heating and the background for the experiments. In this case the BETS interlocks the SPS extraction.

Until the interferometric measurement is ready, the value for the gap calculated from the LVDTs will be used as BETS input. The change from the LVDT gap calculation to the interferometric gap measurement as input is transparent for the BETS.

MSI Current Interlock

The current in the injection septa (MSI) are presently protected against fast changes by the Fast Magnet Current Change Monitors (FMCM) interlock. The current value itself is protected by the SPS power converter hardware interlock (FEI) which is based on the measured current and calibration tables. Due to the lack of passive protection elements downstream the MSI it was deemed important to monitor and interlock the MSI current by the BETS. To keep modifications on the BETS side to a minimum, the present MSI power converter electronics will be replaced by an FGC LHC power converter electronics. This also allows to easily synchronise foreseen de-gaussing cycles of the MSI with the LHC ramp. The MSI power converter will be linked via fiber optics to the BETS. The BETS transfer function translates the current into an energy value; on the BETS side it is checked if the current stays within its limits corresponding to a $1\text{-}\sigma$ trajectory oscillation and the energy within 450 ± 1 GeV.

The same argument of missing horizontal passive protection elements holds for the strong bending magnets at the end of the transfer lines downstream of the TCDI collimators. Extending the BETS interlock on these magnets shall be envisaged.

TCDI Gap Interlock

After changing to the Q20 optics in the SPS and deploying a new optics also for the transfer lines TI 2 and TI 8 in

September 2012 the gaps of the injection protection collimators (TCDI) were not adapted. To avoid such a failure in the future a concept similar to the SIS β^* check as for the LHC ring is suggested. A TCDI gap control parameter (TGCP) needs to be defined for the transfer line optics, just as β^* is defined for the squeeze functions. This will be used by the SIS-SMP-MTG chain to check the gaps in the TCDI, just as β^* is used for the gap control of the tertiary collimators (TCTs). For each transfer line optics the quadrupole currents have to be stored and associated with a unique virtual β^* . The SIS reads reference settings, compares to published extraction currents for every cycle and in case the settings are within tolerance the value is published, otherwise zero is published.

On the TCDI side the TGCP value is read and checked if within limits.

The TCDI settings, TGCP values and optics are stored in a single beam process; if the beam process is wrong, the SIS check will fail.

Certain features need to be added to the existing infrastructure, like reference settings for the transfer line quadrupoles and TGCP values, TGCP limits for the TCDIs and additional SIS code. These implementations will be done until the end of the year, the interlock functionality can be tested without beam during machine checkout.

Injection Beam Loss Monitors

The motivation to modify the beam loss monitoring (BLM) system in the injection region originates from avoidable beam dumps at injection. Loss showers from the transfer line collimators (TCDI) hit from the outside of the cryostat the sensitive LHC loss monitors where the tunnels of the transfer lines TI 2 and TI 8 merge with the ring tunnel. Even if higher dump thresholds were acceptable in this region at injection energy, the saturation level of the ionization chambers presents a limit. To overcome this dynamic range limitation, little ionization chambers (LIC) were tested and after validation installed. They allow to move the upper dynamic range limit by a factor 10 compared to the standard ionization chambers (IC). For the new monitors the threshold limit can be overcome if the higher thresholds are accepted during the time the machine is at 450 GeV injection energy. The new monitors are installed such that redundancy between the well tested ICs and the new LICs is kept. The ICs where higher thresholds would be required to keep machine availability at injection, are connected to blindable crates. These crates will have the possibility to receive a timing signal and accordingly blind out the interlock input at the moment of injection. The criterion to select monitors which shall have the blind out possibility is a factor 5 margin between the operational loss level and the dump thresholds. Also, the expected loss levels should be within a reasonable signal to noise ratio. The loss levels which entered the analysis considered operation with TCDI half gap openings of 4.5σ . Since the measured LHC aperture was larger than expected, the TCDIs were opened by 0.5σ to reduce the number of unnecessary

dumps at injection. The future TCDI opening depends on the available aperture after LS1. During LS1 two new processing crates were installed, one per injection point, and the cabling was modified to route all blindable monitors to those crates. The deployment strategy of this blindable system includes as first step for the BLM team to finish off all LS1 upgrades of the BLM core system. Then a 'firmware light' will be prepared to be ready for deployment in technical stop 1 (May-2015). This firmware will be used in the blindable crates only and not affect the standard BLM firmware. From TS1 onwards the blinding functionality will be commissioned, deployed and monitored. The commissioning experience with beam will allow to decide on the eventual need of the blinding option.

CONCLUSIONS

The injection kickers have been improved in terms of heating, UFOs and electron cloud and re-installed in the tunnel. Presently the high-voltage conditioning and vacuum tests are ongoing. Both systems should be ready for the transfer line tests at the end of November.

The beam dump system modifications included upgrades of the TSDS powering and retriggering line with the consequence of potentially reduced availability but improved safety. The remaining vertical dilution kicker tank was installed. The dump absorber TCDQ was replaced by a 50% longer jaw of different material and improved electronics. Unforeseen sparking in the dump kicker generator switches was solved; the system should be ready for 7 TeV operation. Margins in the planning allow to recuperate the delay of the reliability run by the end of the year.

New interlocks are foreseen or have already been installed. A redundant position interlock of the TCDQ jaw on a new BETS is ready. The gap control of the transfer line collimators will be implemented during the coming weeks and can be tested without beam in the machine checkout. An interlock on the injection septum current will be connected as soon as the FGC power converter has been installed. The interlock on the direct TDI gap measurement is installed and being tested on a spare; its installation is foreseen for the winter stop 2015/16.

For the blindable beam loss monitors it is planned to have a hardware solution ready for the first technical stop; from then on the system shall be commissioned, deployed and monitored. The experience with beam will allow to decide on the eventual need of the blinding option.

REFERENCES

- [1] W. Bartmann et al., "LHC Transfer Lines and Injection Systems", 5th Evian Workshop, Evian, France, June 2014, <http://indico.cern.ch/event/310353/session/4/contribution/16/material/paper/0.pdf>
- [2] N. Magnin et al., "LBDS Kickers Operational Experience During LHC Run 1 and Planned Changes During LHC Long Shutdown 1", MPP Workshop, Annecy, France, March 2013, <https://indico.cern.ch/event/227895/session/4/contribution/19/material/paper/0.pdf>

- [3] N. Magnin et al., "LHC Beam Dumping System Status and Readiness for LHC Run II", 5th Evian Workshop, Evian, France, June 2014, <http://indico.cern.ch/event/310353/session/4/contribution/17/material/paper/1.pdf>