

# HL-LHC PLANNED ACTIVITIES DURING LS2- ACCELERATOR

I. Béjar Alonso, CERN, Geneva, Switzerland

## Abstract

The HL-LHC schedule aims at the installation of the main HL-LHC hardware during the Long Shutdown 3 (LS3), together with the final upgrade of the experimental detectors (so-called upgrade Phase-II). However, a few items like the new cryogenic plant for P4, the 11 T dipole for the Dispersion suppressors (DS) collimation in P2 (for ions), the Superconducting (SC) links in P7 and several prototypes for the collimation, beam instrumentation and injection and beam dump systems are already foreseen for the Long Shutdown 2 (LS2). This paper describes the main activities that the project plans to carry out during LS2

## HL-LHC BASELINE

The first HL-LHC Baseline was presented in July 2014 [1] to the LHC Machine Committee. Together with the Baseline were presented a series of options whose objective is to mitigate some of the risks already identified for the operation of LHC and in case of late delivery/failure of one of the baseline components. The complete description of the systems belonging to the baseline and to the options can be found in the HL-LHC conceptual specification (CS) series [2]. The CSs provide the scope, benefit for the machine performance and equipment performance objective for all mayor equipment/systems (hereafter components) of the HL-LHC. The CSs contain also their preliminary technical parameters, configuration and installation constrains, interface parameters and schedule.

The project is structured in Work Packages (WPs). Each WP integrates the components of the same nature. There are presently 17 WPs of which three are WPs giving global support to the component driven WPs (See Fig1).

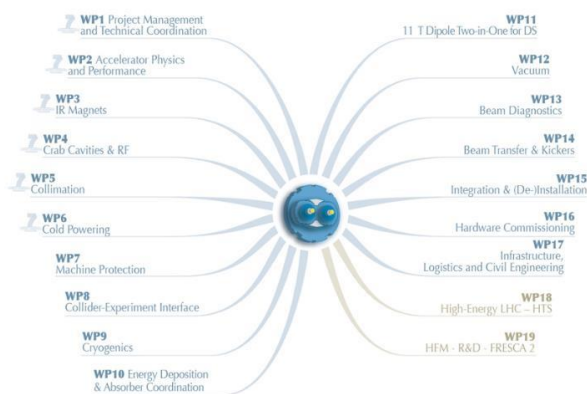

Figure 1: HL-LHC Work Packages

## SCHEDULING STRATEGY

The activities of the HL-LHC follow the HL-LHC life cycle (See Fig 2) [3]. The first draft Master Schedule was

prepared using the schedules prepared by the WP Leaders (WPL) during the preparation of the CSs to which was added the different constrains indicated in the CSs and on the System Architecture and interface identification documents [4].

The draft Master Schedule was after completed with other variables such as those linked to the other operation and consolidation works already known and to the machine constrains such as the timing of the yearly technical stops (YETS) and the LSs.

It was also taken in consideration the ALARA principle to minimize the doses to be taken by workers during the desinstallation/installation tasks.

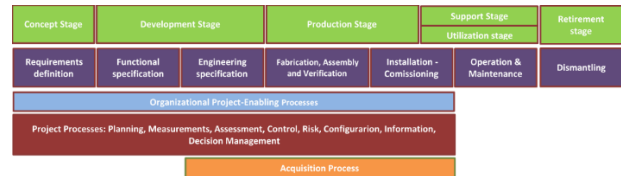

Figure 2: HL-LHC Life cycle processes.

The combination of the draft Master Schedule with the different constrains provided the first Installation and Commissioning schedule for the HL-LHC components during LS2.

Even though the objective of the HL-LHC Project is to distribute as homogenously as possible the different tasks so to decrease the pick requests during LS3 of certain support services, in no case HL-LHC will jeopardize resources required for the completion of the LHC Injectors Upgrade (LIU) or consolidation Projects.

## POTENTIAL INSTALLATION ACTIVITIES DURING LS2

It have been identified installation activities for 10 of the 17 HL-LHC WPs during LS2. Here after we will described the different activities by WP.

### WP3 Insertion magnets

WP3 main scope is the insertion region magnets (while the 11T dipoles required in the DS region is described in WP11).

The Achromatic Telescopic Squeezing (ATS) is the baseline optics for HL-LHC The ATS optics can be fully exploited in the LHC by an additional lattice sextupole in Q10 (MS10) of IR1-IR5 and a stronger Q5 in IR6 in order to keep a balanced  $\beta^*$  reach in ATLAS and CMS.

The additional MS in Q10 is needed to bring the  $\beta^*$  reach at 7 TeV of the pre-squeeze optics to 44 cm at 7 TeV instead of 48 cm already taking counting on the lattice sextupoles at 600A and to compensate the geometric aberrations of the MS14 that are enhanced by the blow-up in the arc [5].

IR6 optics is very rigid due to position of the quadrupoles and internal phase advances. While there are

still several options under study, among them the possibility to double the MQY (See Fig. 3), it is clear that to fully exploit the ATS optics the Q5 in P6 will have to be replaced by a stronger Q5.

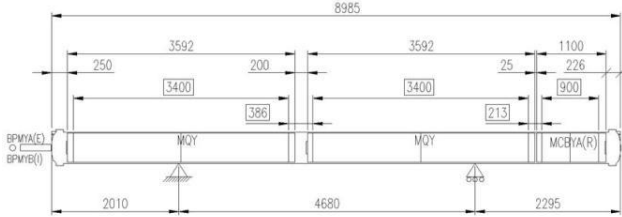

Figure 3: Q5 cold mass Proposal for HL-LHC

To reduce the overload of CERN teams the present baseline is to replace the Q5 during LS2. This will open also synergies with the other works on P6.

#### WP4 Radio Frequency systems

Until this moment no specific works have been identified for LS2 for the LHC crab cavities (CC) but it is important to underline that it is foreseen to test under SPS beam two types of crab cavities before LS2. The validation Run requires dedicated SPS MD time. Failure to test the CC under SPS beam before LS2 or a non-conclusive/negative result could imply a delay or impossibility to install the CCs during LS3.

#### WP5 Collimation system

The present collimation system is operating according to design. LHC Run 2 will show if its impedance has to be reduced in case of beam instabilities at nominal intensity. While it can be discussed if the future modifications can be considered as part of the LHC consolidation or being part of the HL-LHC, it is clear that we should get prepared testing prototypes of new collimators or collimation systems capable to protected components during the large change of the collision beam parameters or just from the beam halo.

Together with the test of prototypes. WP5 will have to provide the new collimators in the DS region of P2 where leakage of off-momentum particles into the first and second main superconducting dipoles has already been identified as a possible LHC performance limitation for ion collisions.

Run 2 will show also if it might also be needed to implement the same solution in the DS around IP7 during LS2, which at present does not seem required.

During LS2 it is foreseen to continue the installation of the new secondary collimators (TCSPM) and tertiary collimators (TCTPM) prototypes based on advanced robust and low-impedance materials. It is also planned the installation of the Target Collimator Long Dispersion suppressor (TCLD) in P2 together with the 2 11T dipoles that will replace a main dipole in the DS region.

The Hollow Electron Beam system is presently under evaluation for controlling the beam halo. In case of approval its installation during LS2 could be considered.

#### WP6 Cold Powering

The purpose of the Cold Powering Work Package is to remove to radiation free areas sensitive power converters and Distribution feedboxes (DFBs) so to improve availability, reduce radiation dose to personnel intervening on such equipment and free space in the tunnel. This requires the use of Superconducting links containing tens of High Temperature (HTS) cables feeding different circuits and transferring all together up to about 150 kA.

At P7 it is proposed to move the power converters and current leads to the TZ76 gallery. This will imply two superconducting links going up to RR73 and RR77.

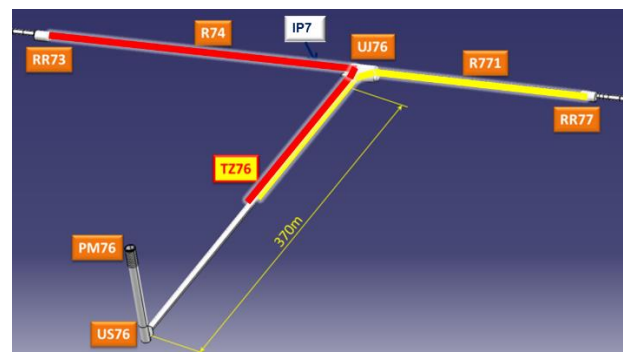

Figure 4: P7 Superconducting link routing

The deployment of the system was foreseen for LS2 but a recent evaluation of the powering in P7 has shown that other alternative scenarios will be more convenient for HL-LHC. Therefore, the SC links will not be installed in P7 in LS2 and most probably neither in LS3.

#### WP7 Machine Protection

No works are foreseen during LS2 for the Machine protection, interlocks and availability WP.

#### WP8 Experiments collider interface

The ALICE and LHCb experiments will be upgraded during LS2. The luminosity increase requested by LHCb does not require any change to the magnet layout but should be accompanied by an improved shielding (Passive absorber for neutrals – TAN) on both sides of the experiment. The new TAN has been renamed mini TAXN and will have to be installed during LS2, according to the upgrade of the experiment.

#### WP9 Cryogenics

The upgrade of the cryogenic system for HL-LHC includes among others the design and installation of a new 4.2 K cryogenic plant at Point 4 (P4) for the Superconducting Radio Frequency (RF) cryo-modules and other future possible cryogenic equipment (e-lens, RF harmonic system). Fig. 6 shows the baseline architecture of the upgraded cryogenic system in P4. The installation is foreseen during LS2. Presently other scenarios are under evaluation, too. The alternative scenario would consist of an upgrade of one of the existing refrigerator of

Point 4 to fulfil the required cooling capacity of existing SRF modules with sufficient margin, while keeping the baseline new distribution scenario. This modular and staged approach would allow the installation at a later stage of a new and dedicated refrigerator adapted to the loads presently under definition.

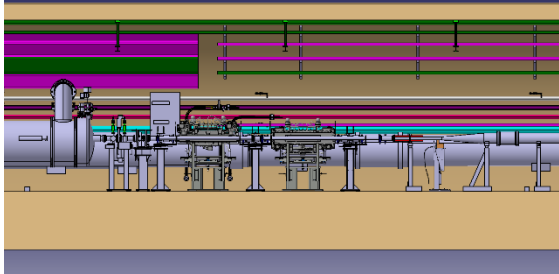

Figure 5: Integration miniTAXN in PC4L8

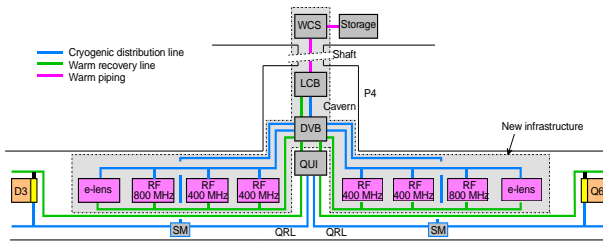

Figure 6: New Cryogenics P4

### WP11 11T Dipole for the DS Collimators

As indicated in the description of the work belonging to WP5 two 11T dipoles will replace some of the main dipoles (MB) in the dispersion suppressor (DS) regions of LHC to create space for additional collimators, which are necessary to cope with losses (off-momentum particles) not foreseen in the nominal LHC design (See Fig.7).



Figure 7: 11T Dipoles with DS collimator

The full assembly will house two 6.252 m long 11T dipole, plus a by-pass cryostat installed in-between. The by-pass cryostat ensures the continuity of the cryogenic and electrical circuits and comprises cold to warm transitions on the beam lines in order to create a room temperature vacuum sector for the collimator.

For LS2, the present plan is to replace 2 main dipoles MB.A10L2 and MB.A10R2 in P2 with 4 11 T magnets and 2 by-pass cryostats. The installation in LS2 will concern LSS2 only, to cope with the upgrade of the ion beams. Here the uncertainty is given by the readiness of the 11 T dipole itself, to be proved in 2015.

### WP12 Vacuum system

The HL-LHC beam vacuum system must be designed to ensure the required performance when beams with HL-LHC nominal parameters circulate. The different components to be installed during LS2 shall be compliant

with the vacuum requirements expressed by the WP on their CS.

During LS2 will be actively supporting the equipment groups for their vacuum elements such as beam pipes and beam screens.

Recent evaluations of the electron cloud show that will be also necessary to coat the IR regions on P2 and P8. This work has still to be precisely planned, however there are good reasons (including ALARA) to consider to be done during LS2.

### WP13 Beam Instrumentation and Long-Range Beam-Beam Compensation

The extensive array of beam instrumentation with which the LHC is equipped, has played a major role in its commissioning, rapid intensity ramp-up, and safe and reliable operation. HL-LHC brings a number of new challenges in terms of instrumentation. The Beam Loss system will need a significant upgrade. In particular cryogenic beam loss monitors are under investigation for the new inner triplet magnets. Radiation tolerant integrated circuits are also under development to allow the front-end electronics to sit much closer to the detector. The use of crab cavities also requires the development of new diagnostics equipment.

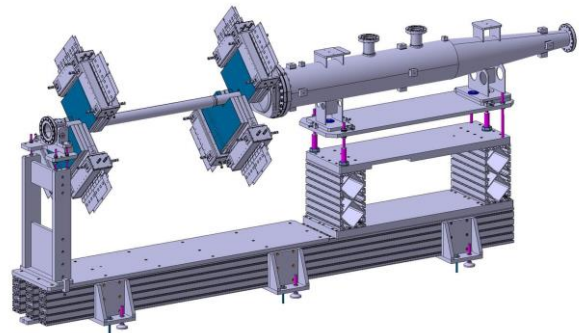

Figure 8: Beam Gas Vertex detector (BGV)

During LS2 there will be an intensive campaign in which certain prototypes will be tested such for the Fast Wire Scanners, the Interlock abort monitor and halo diagnostic systems. It will also be installed a second BGV on the right side of IP4

### WP14 Injection and Dumping Systems

Several changes are under study for the different LHC beam transfer systems. Among them, those for LS2 include a new injection absorber (TDIS) that is foreseen to comprise shorter absorbers accommodated in separate tanks, two auxiliary collimators (TCLIA and TCLIB) (its need is under evaluation) and an injection protection mask (TCDD). It is also foreseen to install a new prototype for the Injection kicker magnet (MKI)

### WP17 Infrastructures

Several minor civil engineering works would be needed to host the new cryogenic plant in P4. The installation of most part of the new equipment would require the

intervention of several service groups such alignment or electricity.

The study of the different alternative installation for the P1 and P5 cryogenics, warm powering and crab cavities shows that some of them will require heavy civil engineering during LS2. Only during 2015 will be clear the correct planning of those works.

## **ACKNOWLEDGMENT**

This paper was prepared thanks to the contributions of the HL-LHC WP Leaders.

## **REFERENCES**

- [1] L. Rossi, "HL-LHC Baseline", LMC 184, CERN, July 2014,;  
<https://espace.cern.ch/lhc-machine-committee/default.aspx>.
- [2] HL-LHC Project., "Scope Management"  
<https://edms.cern.ch/nav/P:CERN-0000096404:V0/P:CERN-0000096368:V0>.
- [3] I. Bejar Alonso, "HL-LHC Life Cycle Processes";  
<https://edms.cern.ch/document/1346952>
- [4] HL-LHC "WPs Architecture"  
<https://edms.cern.ch/nav/P:CERN-0000096404:V0/P:CERN-0000096398:V0>.,
- [5] R. De Maria, S. Fartoukh, 64th LMC 2010, sLHC PR.50, sLHC PR.55.
- [6] LMC199 <http://indico.cern.ch/event/358569/>