

CATHI Final Review Meeting

Monday 22 September – Friday 26 September, 2014

Barcelona, Spain

Book of abstracts

Table of contents

European ITN programme feedback and future (1).....	4
The HIE-ISOLDE project at CERN (2).....	5
SRF developments, problem solving and teamwork at the HIE-ISOLDE accelerating structures working group (3).....	6
An overview of the HIE-ISOLDE Design Study (4).....	7
Exploring the nuclear landscape with HIE-ISOLDE (5).....	8
HIE-ISOLDE installation progress (6).....	9
Superconducting RF cavity review (7).....	11
The R&D on HIE-ISOLDE superconducting quarter-wave resonators (8).....	12
Niobium coatings for the HIE-ISOLDE superconducting accelerating cavities (9).....	13
Status of the HIE-ISOLDE high beta cryomodule assembly at CERN (10).....	14
Beam instrumentation R&D in Europe and status of other ITN projects (11).....	15
Beam diagnostics for HIE-ISOLDE (12).....	16
HIE-ISOLDE – MATHILDE system presentation (13).....	17
Integration study for HIE-ISOLDE: 3D modelling, data and documentation management (14).....	18
Overview of the new high level software applications developed for the HIE-ISOLDE superconducting linac (15).....	19
New electromagnets for HIE-ISOLDE: from conceptual design to magnetic compatibility studies (16).....	20
TSR@ISOLDE (17).....	22
Brookhaven EBIS program: operation and development (18).....	23
Development progress of the charge breeder for HIE-ISOLDE and TSR@ISOLDE (19).....	24
Beam dynamics design studies for 10 MHz bunch frequency of post-accelerated RIBs at HIE-ISOLDE (20).....	25
Target voltage modulator development for the On-Line Isotope Mass Separator, ISOLDE (21).....	26
A new modulator system for HIE-ISOLDE (22).....	27
Technical studies for the HIE-ISOLDE frontend upgrade (23).....	28
Automatic tuning of complex beam-lines (24).....	29
A multi-reflectron Time-of-Flight mass spectrometer (25).....	30
Design study for a new high resolution separator at ISOLDE (26).....	31
Low level control for the HIE-ISOLDE high resolution separator magnet (27).....	32

Improvements and future developments for the radio frequency quadrupole cooler and buncher at ISOLDE (28).....	33
The ESS superconducting Radio-Frequency linac activities and implementation (29).....	34
RIB at TRIUMF: From ISAC to ARIEL (30).....	35
SEPS: a being built exotic beam facility at INFN-LNL (31).....	36
ECOS-LINCE: A proposal for a high-intensity stable-beam facility for nuclear structure and reactions (32).....	37
Overview of ISOL facility at RISP (33)	38
The SPIRAL 2 – GANIL facility: the technical developments made for the highly intensive radioactive ion beams from ISOL production (34).....	39
CERN-MEDICIS: a new facility (35).....	40
The ISOL@MYRRHA project (36).....	41
Extending the scope of the ISOLDE Laser Ion Source (37).....	42
Target area infrastructure, cooling and ventilation (38).....	43
Radiation related estimations near ISOLDE tunnel with FLUKA (39).....	44
ISOLDE HRS and GPS dumps: evaluation of present and future operation (40)	45
Recent results on the development of the SPES target-ion source complex (41).....	46
ESR9: target conceptual design (42).....	47
Study of prototype refractory ceramics (SiC and Al ₂ O ₃) with open unidirectional porosity (43)	48
Radiation protection study for the HIE-ISOLDE project (44).....	49
Vaccum: use of dry pumps and filters to avoid propagation (45).....	50
Evaluation of a potential explosive front-end (46)	51

European ITN programme feedback and future (1)

Corresponding Author: seamus.hegarty@cern.ch

CATHI stands out among the Marie Curie projects as one of the 11 Initial Training Networks (ITN) coordinated by CERN, not just because of its size in terms of funding and researcher months, but above all because it is one of only three monosite ITNs funded in the period 2008-2012. The overview talk will look at aspects related to our relations with Brussels in helping us implement and run the ITN, the people aspects (CATHI is in the category of People Actions) and the training which was central to the development of the recruited researchers. This will be followed by a brief look at what is to come in terms of the Marie Skłodowska-Curie Actions under Horizon 2020 which is the successor to the Seventh Framework programme.

The HIE-ISOLDE project at CERN (2)

Corresponding Author: Yacine.kadi@cern.ch

Co-authors: A-P. Bernardes, E. Bravin, J. Bauche, S. Calatroni, R. Catherall, M. Garcia Borge, J-C. Gayde, T- Giles, S. Hegarty, Y. Muttoni, V. Parma, E. Siesling, Th. Stora, G. Vandoni, W. Venturini Delsolaro, V. Vlachoudis, J. Vollaire, D. Voulot, F. Wenander

The research with radioactive beams has strengthened the link between technical developments and physics output. The study of radioactive beams allows us to follow the evolution of nuclear structure over extended regions in the nuclear chart. ISOLDE has nowadays a vast variety of species produced, more than 1000 nuclei from almost 70 elements, the largest number by far of the existing ISOL-facilities. A key feature of the REX-ISOLDE complex is that essentially all isotopes produced can be charge-bred and accelerated further up to 3 MeV/u. The present energy range limits the experimental program to Coulomb excitation of light and intermediate mass nuclei and to transfer reaction for the lightest species.

The ISOLDE facility has been expanded several times in order to continue being a reference facility. Improvement of beam quality, increase in intensity and availability of new radioactive beams will boost decay experiments as well as the study of ground state properties as, for instance, Penning trap mass measurements that continuously refine our understanding of the nuclear mass surface. An energy upgrade will make all produce nuclei available for reactions up to and above the Coulomb barrier opening new avenues from the physics point of view. The enlarged dynamic range, first to 5.5 MeV/u and in a later stage to 10 MeV/u, will allow the optimization in each case with respect to cross section and reaction channel opening.

A major upgrade of the present facility, High Intensity and Energy ISOLDE (HIE-ISOLDE), was approved to fully exploit the latest developments and significantly increase the ISOLDE scope. The HIE-ISOLDE project provided CATHI Early Stage Researchers (ESRs) and Experienced Researchers (ERs) with unparalleled research training opportunities in the framework of established, trans-national research networks (ISOLDE Collaboration, EURONS, ENSAR). It also provided hands-on experience through participation in the R&D, construction and commissioning of the super-conducting linac systems and in the design study to prepare for a future increase in intensity of the PSB beam.

In this talk the present status of the project, and the future plans will be presented.

SRF developments, problem solving and teamwork at the HIE-ISOLDE accelerating structures working group (3)

Corresponding Author: walter.venturini.delsorao@cern.ch

The HIE-ISOLDE working group on accelerating structures was the crucible of all the developments which made possible to achieve the specified performance of the HIE ISOLDE superconducting cavities based on the Nb/Cu sputtering technology. The group work evolved from the design of the high beta cavity, to the setting up of the necessary infrastructures for the cavity processing, chemical polishing, Nb coating, RF testing at cryogenics temperatures. Over the years, a considerable amount of technical know-how and of scientific understanding has been accumulated. These developments include optimization of the Nb film sputtering parameters, design iterations of the tuning and coupling systems, understanding of the frequency shifts along the cavity production process, studies on the dependence of residual resistance on cool down parameters, on microphonics, on flux trapping, on multipacting and field emission conditioning and on measurement accuracies. Discussions have already started on the low beta cavities needed for the phase III of the project. The weekly meetings allow a close follow up and coordination of the teams which carry out the series production at CERN of the HIE ISOLDE cavities, together with the procurement of cavity ancillaries in time for the assembly of the first cryomodule in clean room. The CATHI fellows were the main actors along this endeavour. This contribution will highlight ups and downs and milestones achieved in our continuing enterprise focused in delivering accelerating structures for the HIE ISOLDE SC Linac.

An overview of the HIE-ISOLDE Design Study (4)

Corresponding Author: Richard.catherall@cern.ch

The On-Line Isotope Mass Separator ISOLDE [1] is a facility dedicated to the production of a large variety of radioactive ion beams (RIB) for a great number of different experiments. Over 1000 radioactive nuclides from 70 elements can be produced in thick high-temperature targets via spallation, fission or fragmentation reactions with the PS-Booster pulsed proton-beam. With the arrival of CERN's new linear accelerator Linac 4 [2,3], ISOLDE will have the possibility to exploit a factor of 3 increase in proton-beam intensity and a possible proton-beam energy increase from 1.4 GeV to 2 GeV [4].

After 20 years of successful ISOLDE operation at the PS-Booster, a major upgrade of the facility, the HIE-ISOLDE (High Intensity and Energy ISOLDE) project was launched in 2010. It is divided into three parts; a staged upgrade of the REX post-accelerator to increase the beam energy from 3.3 MeV/u to 10 MeV/u using a super-conducting Linac, an evaluation of the critical issues associated with an increase in proton-beam intensity and a machine design for an improvement in RIB quality. The latter two will be addressed within the HIE-ISOLDE Design Study.

<i>Protons/pulse</i>	<i>Intensity (μA)</i>	<i>Energy (GeV)</i>	<i>Cycle (s)</i>	<i>Power (kW)</i>
3.3×10^{13}	2.2	1.4	1.2	3.1
1×10^{14}	6.7	1.4	1.2	9.3
1×10^{14}	6.7	2.0	1.2	13.3

Table 1. Projected beam parameters considered within the HIE- ISOLDE Design study. Based on ISOLDE receiving 50% of available proton pulses from the PS-Booster.

Although the CATHI project comes to an end, work on the issues addressed within the Design Study will continue. This presentation will give an overview of the issues addressed during the last 4 year period and will outline areas of study critical to accepting an increase primary beam intensity and energy.

References

- [1] A. Herlert, *The ISOLDE Facility*, Nuclear Physics News, Vol. 20/ No.4, 2010
- [2] Linac4 Technical Design Report, CERN-AB-2006-084 ABP/RF
- [3] M. Vretenar *et.al.*, *Progress in the Construction of Linac4 at CERN*, 26th International Linear Accelerator Conference, *LINAC12*, Tel Aviv.
- [4] R. Garoby *et al.*, "Plans for the Upgrade of the LHC Injectors," IPAC2012, *Conf. Proc. C1205201* (2012) TUXA02; <http://www.JACoW.org>

The research leading to these results has received funding from the European Commission under the FP7-PEOPLE-2010-ITN project CATHI (Marie Curie Actions - ITN). Grant agreement no PITN-GA-2010-264330.

Exploring the nuclear landscape with HIE-ISOLDE (5)

Corresponding Author: maria.jose.garcia.borge@cern.ch

The ISOLDE facility at CERN has as objective the production, study and research of nuclei far from stability. The facility provides low energy radioactive beams and post-accelerated beams. Over 700 isotopes of more than 70 elements have been used in a wide range of research domains, including cutting edge studies in nuclear structure, atomic physics, nuclear astrophysics, and for applications in condensed-matter and life sciences.

The nuclear physics studies focused at first on fundamental properties (mass, spin, magnetic moments, decay modes...) of exotic nuclei using low energy beams of 30-60 keV. New fields of research opened up in 2001 when the Radioactive beam EXperiment, REX, started operation and allowed reaction experiments to be carried out up to 3 MeV/u. Unique feature of these post-accelerated beams is that essentially all isotopes produced can be charge-bred and accelerated further. So far more than one hundred different beams have been post-accelerated and used for physics studies. In two decades of physics with post-accelerated beams beautiful results have been obtained at ISOLDE exploring, by Coulomb excitation with the Miniball HPGe-array the structure and shape of nuclei under study [1]. A good example being the recent studies of Ra and Rn isotopes published in Nature [2]. In this work it was found that ^{224}Ra had a permanent octupole deformation character in its ground state while ^{220}Rn had only dynamic octupole correlations.

Presently the facility is having an upgrade, the HIE-ISOLDE project, which aims to improve the ISOLDE capabilities in a wide front, from an energy increase of the post-accelerated beam to improvements in beam quality and beam purity. The first phase of HIE-ISOLDE will start for physics in the autumn of 2015 with an upgrade of energy for all post-accelerated ISOLDE beams up to 4.3 MeV/u for $A/Q = 4.5$, reaching 5.5 MeV/u at the start of the running period in 2016. The implementation of two extra cryomodules to reach acceleration energies of 10 MeV/u should be realized early 2017. In addition improvements in several aspects of the secondary beam properties such as purity, ionization efficiency and optical quality are addressed to accommodate a roughly fourfold increase in intensity foreseen for 2020.

Currently the facility and the experimental equipment undergo extensive transformation to commit to the new physics challenges [3]. Since May 2010 more than 35 letters of intent have been received. More than 600 shifts have been approved for day one physics. An ample variety of subjects will be addressed from isospin symmetry, collectivity versus single particle behavior, study of magicity far from stability, deformation, shape coexistence as well as quadrupole and octupole degrees of freedom. In this presentation the day one HIE-ISOLDE experiments will be discussed.

References

- [1] P. Van Duppen and K. Riisager, J. Phys. G. Nucl. Part. **38** 02405 (2011).
- [2] L. P. Gaffney et al., Nature 497, 309 (2013).
- [3] *HIE-ISOLDE, the scientific opportunities* ed. by K. Riisager, P. Butler, M. Huyse and R. Krücken, CERN Report, CERN-2007-008.

HIE-ISOLDE installation progress (6)

Corresponding Author: Erwin.siesling@cern.ch

The long shutdown of the CERN accelerators in 2013-2014 was used to upgrade the general infrastructure to the needs of HIE ISOLDE with minor disruptions to the physics programs. For this the full ISOLDE water-station has been replaced and became operational in time for the 2014 Low Energy run of the ISOLDE facility. Two new buildings were added to the existing ISOLDE facility to house the different HIE ISOLDE services. On their roofs cooling towers and chiller units have been installed.

The acoustically isolated Compressor building contains the now fully installed and tested water cooling system providing the warm elements of the HIE ISOLDE High Energy Beam Transfer lines as well as the cryo plant and different power convertors and RF amplifiers with 27C demineralized water. An additional chiller system has been installed to be able to run the existing REX NC Linac RF cavities and amplifiers at a lower water temperature of 20C. As far as the cryogenic system is concerned the two He tanks are in place outside the building and the installation of the refurbished ALEPH compressor units is ongoing.

In the Cold Box building the HVAC systems for controlled air cooling of the ISOLDE experimental hall and service buildings have been installed and tested. RF systems as well as the SC Solenoid power supplies are being installed. The ALEPH Cold Box is being refurbished and will be installed towards the end of the summer. It will provide 700W of cryogenic cooling power sufficient for the second phase of the super conducting linac when four high-beta cryomodules deliver beams up to 10MeV/u.

In the ISOLDE experimental hall, as part of the HIE ISOLDE civil engineering works, walls were cut and new trenches installed to house the linac shielding tunnel and allow passage for handling of the cryomodules. Air ducts have been mounted along the walls and ceiling to cool the hall as well as the different equipment. The shielding tunnel which consists of more than 550 tons of concrete to assure operational radiation values well below the limitations for a CERN surveyed area is in place. Its roof will be closed by the end of the summer. For safety with regard to oxygen deficiency inside the tunnel a solution was found in guiding the He release outside via the tunnel roof. The metal structures carrying the cryogenic distribution line and jumper boxes as well as those for the HEBT infrastructure and HIE ISOLDE equipment platform are in place whereas the cryogenic distribution line and jumper boxes themselves feeding the cryomodules inside the tunnel with liquid He coming from the cold box at a temperature of 4.5K will be installed towards the end of this year.

For the three HEBT lines the elements' supports are all in place. Cooling water and vacuum exhaust tubing is about to start after which the first quadrupoles, correctors and dipoles as well as diagnostic boxes will arrive to the hall. Controls, DC and RF cables with a total length of more than 65 kilometres are being installed and power supplies, beam instrumentation and vacuum racks are in place.

To assure the ISOLDE Low Energy Physics programs in parallel with the HIE ISOLDE installation works the ISOLDE experimental hall is being divided into a working zone and an experimental zone. Access and the wear of safety equipment will be adjusted accordingly.

This talk will give you an insight in the ongoing installation activities and those yet to come. It will give you an overview on the changes to the existing ISOLDE facility and the schedule of the different stages of installation of the HIE Isolde project.

Superconducting RF cavity review (7)

Corresponding Author: Sébastien Bousson, bousson@ipno.in2p3.fr

Historically, the Superconducting Radio Frequency (SRF) technology gained maturation with the developments on electrons cavities (adapted to $b=1$ particles) especially under the momentum given by several teams worldwide working on the framework of the future linear collider (Tesla Technology Collaboration). These efforts are still ongoing, for instance now dedicated towards the construction of the European X-FEL.

During the last decade, projects based on proton or ion accelerators have multiplied to follow the increasing demand of high power beams, for a wide range of applications. Thanks to the continuous progress in SRF technology, most of these accelerators are based on low beta superconducting cavities of different type (half-wave, quarter-wave, spoke, elliptical...) and make this particular field very active in many laboratories in Europe and worldwide, giving important perspectives for high intensity beams acceleration.

In this talk, we review the most recent developments in SRF technology performed in the framework of several projects or constructions involving European teams like SPIRAL-2, ESS, MYRRHA, and IFMIF. The HIE-ISOLDE facility, also to be listed as an important European facility construction using the thin-films SRF technology, is covered by another talk in this same workshop.

The same increase of the number of accelerator projects based on low beta SRF technology is observed worldwide. In order to gain perspective, we also quickly review the cavity developments ongoing for the most important ones such as FRIB and PROJECT-X in the USA, SARAF in Israel and the Chinese ADS (C-ADS).

The R&D on HIE-ISOLDE superconducting quarter-wave resonators (8)

Corresponding Author: pei.zhang@cern.ch

Quarter-wave resonators (QWR) were designed to be used in the ongoing linac upgrade of the ISOLDE facility at CERN namely HIE-ISOLDE. The cavities are made of niobium sputtered on copper substrate. They will be operated at 101.28 MHz at 4.5 K providing 6 MV/m accelerating gradient with maximum 10 W power dissipation.

A two-step frequency tuning strategy have been developed. It includes a pre-tuning step on the copper substrate before niobium sputtering by using the cavity outer conductor length. Fig. 1 shows the tuning mechanism of cavity QS1. Then the tuning system could be and has been drastically simplified to compensate only the unavoidable uncertainties induced by the substrate chemical treatment and in the frequency shift during the cool-down process, as well as minimizing the forward power variation during beam operations. This two-step frequency tuning strategy has been successfully applied on three production cavities.

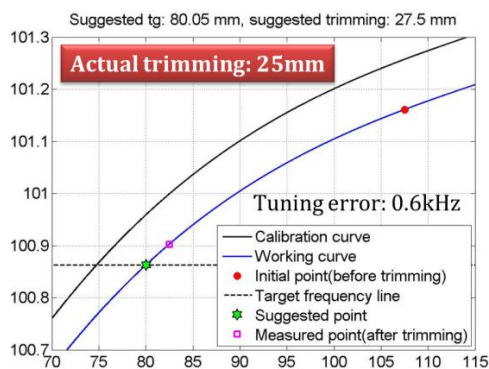

Figure 1: Frequency pre-tuning of QS1.

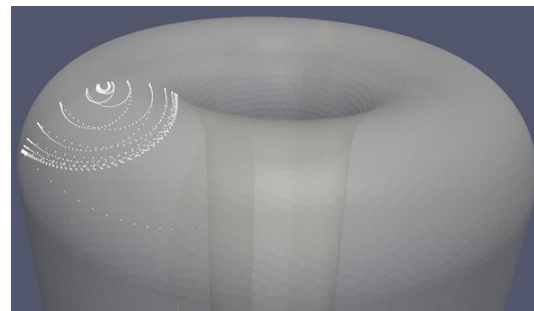

Figure 2: Multipacting electron trajectories.

The multipacting of the high-beta QWRs have been simulated by both CST Particle Studio and SLAC ace3p suite as shown in Fig. 2. The results from the two codes are consistent. Same field level of multipacting onset has also been seen during the cavity RF cold test.

In addition to normal Q0 vs. Eacc measurements during the cavity RF cold test, the impact of thermal gradient and the magnetic flux trapping during the cooldown process on the cavity performance has been carefully studied and correlations have been found.

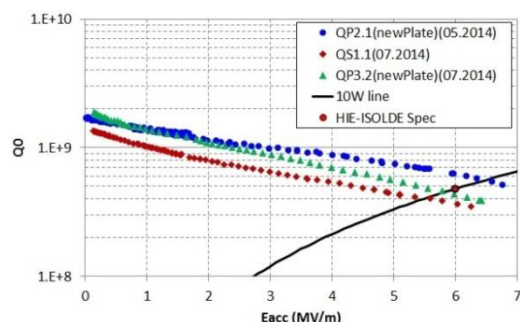

Figure 3: Q0 vs. Eacc for good cavities.

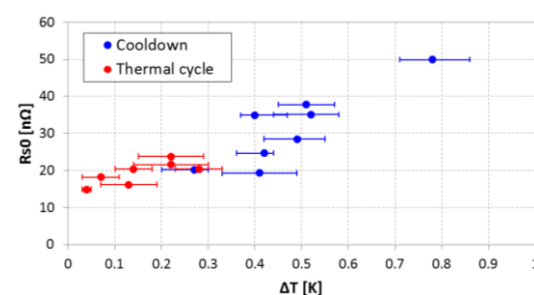

Figure 4: The dependence of residual resistance on thermal gradient.

The frequency tuning strategy and realization, multipacting study and the RF cold test results will be presented.

The research leading to these results has received funding from the European Commission under the FP7-PEOPLE-2010-ITN project CATHI (Marie Curie Actions - ITN). Grant agreement no PITN-GA-2010-264330.

Niobium coatings for the HIE-ISOLDE superconducting accelerating cavities (9)

Corresponding Author: Noemie.marie.jecklin@cern.ch

The HIE-ISOLDE project is the upgrade of the existing ISOLDE facility at CERN, which is dedicated to the production of a large variety of radioactive ion beams for nuclear physics experiments.

The construction of the new superconducting linear accelerator (linac) for the energy increase of the beam (from 3MeV/u to 10MeV/u) requires the production of superconducting accelerating Quarter Wave Resonators (QWR) of two geometries, 12 with a geometrical $\beta=0.063$ and 20 with a geometrical $\beta=0.103$, including an adequate number of spares.

In a first phase two cryomodules of 5 first prototype $\beta=0.103$ SC cavities each are scheduled to accelerate first beams in 2015. The cavities are made of a copper substrate, with a sputter-coated superconductive niobium layer, operated at 4.5 K with an accelerating field of 6 MV/m at 10W RF losses ($Q_0=4.5e8$)

As mentioned, the technology chosen for the production of HIE-ISOLDE superconducting cavities is the Nb/Cu technology, because it is allowing to combine the superconducting characteristics of niobium with the stiffness and high thermal conductivity of the thick Cu substrate, offering a valid alternative to bulk niobium resonators.

Of course, this was done at the expense of the added complication of the sputtering process of the niobium film, which was a challenging task in such a complex cavity geometry.

In this presentation, I will describe the production steps of the first prototype $\beta=0.103$ SC cavities which achieve the required RF-performances, going from the cavity surface treatment to the baseline niobium coating recipe.

Producing one cavity with the baseline recipe takes 4 weeks - two weeks for the niobium coating and another two weeks for the RF characterization. The production sequence comprises the following steps:

- Copper substrate surface treatments : Chemical polishing (SUBU) and passivation (Sulfamic acid)
- Dust-free copper substrate treatment : low pressure (8 bars) ultrapure water rinsing in clean room class 100
- Dust-free system assembly in clean room class 100
- Pre-heating of the copper substrate under vacuum : cavity bakeout temperature (635-655°C), with $T_{bakeout} > T_{coating}$
- Activation of NEG pump inside the chamber
- 8kW-power biased diode coating in several steps
- Dust-free sputtered cavity treatment : low pressure (8 bars) ultrapure water rinsing
- RF measurement

The research leading to these results has received funding from the European Commission under the FP7-PEOPLE-2010-ITN project CATHI (Marie Curie Actions - ITN). Grant agreement no PITN-GA-2010-264330.

Status of the HIE-ISOLDE high beta cryomodule assembly at CERN (10)

Corresponding Author: yann.leclercq@cern.ch

The HIE ISOLDE project aims at increasing the energy of the radioactive ion beams of the existing REX ISOLDE facility from the present 3 MeV/u up to 10 MeV/u for A/q to 4.5. The upgrade includes the installation of a superconducting linac in successive phases for a final layout containing two low- β and four high- β cryomodules.

The first phase involves the installation of two high-B cryomodules. The design of this high-B cryomodule was completed at CERN and the procurement of assembly tooling and the parts for two units is well advanced at the time of writing. The assembly of the first unit has started in August 2014.

The high-B cryomodule houses five high-B superconducting cavities and one superconducting solenoid aligned within tight tolerances. The design provides four adjustment possibilities to be operated at different assembly steps and at different steps of the cool-down procedure. The positions of active components are monitored at all times.

The active components require a cryogenic and steady temperature for efficient operation. This is achieved with two cryogenic circuits; one helium gas circuit at 55K and 13bara, cooling actively a low emissivity nickel plated thermal shield and one helium bi-phase liquid-gas circuit at 4.5K 1.3bara nominal to cool actively the active components and their supporting structure. We present the cryogenic design, the cool-down procedure, estimations for static and dynamic heat loads, the instrumentation layout and the safety considerations.

The cryomodule design presents a common beam and insulation vacuum toward 1.10^{-8} mbar in operation contained in a 15mm thick stainless steel reinforced vacuum vessel. To preserve performance of the RF cavities, a high level of cleanliness is required in operation conditioning the design and requiring assembly in a clean room class100 (ISO5). We present the vacuum design, its instrumentation layout and the technical solutions adapted to the cleanliness requirements.

The main steps of the assembly of the cryomodule are performed in a dedicated class100 (ISO5) clean room equipped with specific tooling. A smaller class100 clean room is used for pre-assembling some components. Before entering the clean rooms, all parts and tooling are individually blank assembled and UHV and dust cleaned. We present the organization of the assembly, the different actors, the tooling, procedures and sequence.

Finally we present the current status of the procurement phase as well as the status of the assembly.

Beam instrumentation R&D in Europe and status of other ITN projects (11)

Corresponding Author: carsten.welsch@cockcroft.ac.uk

Beam diagnostics is a rich field in which a great variety of physical effects are made use of and consequently provides a wide and solid base for the training of young researchers. Moreover, the principles that are used in any beam monitor or detector enter readily into industrial applications or the medical sector, which guarantees that training of young researchers in this field is of relevance far beyond the pure field of particle accelerators. Beam diagnostics systems are essential constituents of any particle accelerator; they reveal the properties of a beam and how it behaves in a machine. Without an appropriate set of diagnostic elements, it would simply be impossible to operate any accelerator complex let alone optimize its performance.

There was a strong requirement for innovative instrumentation to monitor the beams at HIE-ISOLDE. An experienced and an early stage researcher have been working closely together to develop new beam diagnostics for determining the beam's properties in detail. In this contribution, these developments will be put into a broader context by linking them to instrumentation requirements at other low energy ion beam facilities.

Moreover, in addition to [CATHI](#) there has been a dedicated Initial Training Network (ITN) on beam diagnostics at accelerators ([DITANET](#)) which formed the basis for two further projects, [LA³NET](#) and [oPAC](#). Selected research results from these projects, as well as an overview of international training initiatives in accelerator science and technology and the status of these ITNs will also be presented.

Beam diagnostics for HIE-ISOLDE (12)

Corresponding Author: esteban.daniel.cantero@cern.ch

Co-authors: E. Bravin, A. Sosa

Several beam diagnostics devices were developed as part of the HIE-ISOLDE LINAC energy upgrade, in particular for the measurements of the intensity, energy, transverse and longitudinal profiles, and transverse emittance. The beam energy ranges between 300 keV/u and 10 MeV/u and the beam intensities between 1 pA and 1 nA. Faraday cups will be used for the measurement of the beam intensity while silicon detectors will be used for the energy and longitudinal profile measurements. The transverse profiles will be measured by moving a V-shaped slit in front of a Faraday cup and the beam position will be calculated from the resulting profiles. The transverse emittance can be measured using the existing REX-ISOLDE slit and grid system, or by the combined use of two scanning slits and a Faraday cup. The final design of these devices will be presented in this talk, including the results of the experimental validation tests. The production of six short and nine long Diagnostic boxes for the LINAC and HEBT sections by industrial partners is on the final stages. A new electronic card based on the VME standard has been designed and tested for controlling the instrumentation devices, including the actuators' stepper motors, the acquisition chain and the bias voltage required for the Faraday cup. Two main FESA servers have been developed to handle the beam intensity acquisition, the collimators movement, and the energy and time spectra obtained with the Si detectors.

The research leading to these results has received funding from the European Commission under the FP7-PEOPLE-2010-ITN project CATHI (Marie Curie Actions - ITN). Grant agreement no PITN-GA-2010-264330.

HIE-ISOLDE – MATHILDE system presentation (13)

Corresponding Author: guillaume.kautzmann@cern.ch

In the frame of the HIE-ISOLDE project, most of the existing ISOLDE REX line will be replaced by a superconducting Linac in order to upgrade the energy and intensity of the REX ISOLDE facility at CERN. This upgrade involves the design, construction, installation and commissioning of 2 low- β and 4 high- β cryomodules. Each high- β -cryomodule houses five high- β superconducting cavities (6 for the low- β version) and one superconducting solenoid (2 for the low- β version).

Beam-physics simulations show that the optimum linac working conditions are obtained when the main axes of the active components, located inside the cryostats, are aligned and permanently monitored on the REX Nominal Beam Line (NBL) within a precision of 0.3 mm for the cavities and 0.15 mm for the solenoids at one sigma level along directions perpendicular to the beam axis.

The Monitoring and Alignment Tracking for HIE-ISOLDE (MATHILDE) system is based on opto-electronic sensors, precise optical elements, metrological tables and mechanical elements. Some of them will be exposed to non-standard environmental conditions such as high vacuum and cryogenic temperatures. In addition, MATHILDE incorporates a software solution to adjust the sensor observations and broadcast the alignment results.

The presentation gives a general presentation of the system, its current status and latest developments.

Integration study for HIE-ISOLDE: 3D modelling, data and documentation management (14)

Corresponding Author: Eleftherios.zografos@cern.ch

The 3D Integration study for the HIE-ISOLDE project was one of the work packages defined in the CATHI project. The work begun in August 2011 and is currently under way. It has been undertaken by the Integration Section of the EN/MEF Group. The workload was broken down to two main activities; integration of the new machine assigned to E. Zografos and integration of the rest of the facility and services assigned to S. Maridor. The main duties of the integrators were to provide reference to the system designers, to check for compatibility and fitting issues and offer their feedback as input for any redesign required.

The design effort was conducted with the Catia V5TM CAD software and the management of the produced data was done with the Enovia SmarTeamTM PDM tool. Regarding the machine integration, three 3D layout models, corresponding to the initially foreseen installation stages of the new equipment, have been created and maintained.

The machine layout as defined by the physicists conducting the optics study was captured in the so called “skeleton”. Early stage development consisted of the creation of approximate geometries for the main equipment elements. Thereby the necessary space was reserved and initial design reference was provided. This was followed by the replacement of those approximate geometries with exact ones as the system’s design was getting mature enough. The 3D master model is updated regularly upon delivery of new system designs. The final outcome of this process will be a complete model of the HIE-ISOLDE machine layout as it is going to be installed.

Certain supporting activities of the above described process were undertaken. First of all, the produced CAD data had to be managed. Therefore the Hardware Baseline Structure has been created in Enovia SmarTeamTM. E. Zografos was charged with its maintenance as well as the access rights assignment.

A second supporting activity has to do with the management of all the produced documentation regarding the newly designed machine. A structure matching the Hardware Baseline was created for that purpose in EDMS and kept up to date.

Last but not least, in order to establish a common language and thereby facilitate the communication among the project participants the ISOLDE Equipment Naming Convention has been defined. This is to offer a framework for the naming of new equipment and the related documentation so that they can be easily retrievable and accessible.

The final step of the integration effort will be the validation that the actual installation of the new machine is going to comply with the “as designed” model. This effort will be continued throughout the various installation faces in the years to come.

The research leading to these results has received funding from the European Commission under the FP7-PEOPLE-2010-ITN project CATHI (Marie Curie Actions - ITN). Grant agreement no PITN-GA-2010-264330.

Overview of the new high level software applications developed for the HIE-ISOLDE superconducting linac (15)

Corresponding Author: davide.lanaia@cern.ch

The High Intensity and Energy (HIE) ISOLDE project consists of an upgrade of the ISOLDE facility at CERN. With the installation of 32 independently-phased, superconducting (SC) quarter-wave cavities the energy of post-accelerated radioactive beams (RIBs) will be increased from 3 MeV/u to over 10 MeV/u. The large number of cavities will increase the number of parameters to optimise. In order to ensure a fast set-up of the machine during operation and commissioning, new software applications have been developed and an upgrade of the existing software was carried out. Four high level applications have been specifically developed for the SC linac. The first allows the conversion of optics settings into machine settings, and vice versa. The second will aid the phasing of the cavities using and beam energy measurements. In addition to this, a third application, which is under development, will provide a tool for to help phasing the cavities by means of a time-of-flight system (ToF). A similar application was developed, tested and implemented at the ISAC-II SC accelerator at TRIUMF. The last application will automatically generate the phase and voltage settings for the cavities SC linac. In this contribution we will present an overview on the beam commissioning plan with special focus on the new applications and outline how these will be used in commissioning and operation of the new SC linac. A section will be also dedicated to the CERN control tools that are implemented and used at ISOLDE.

The research leading to these results has received funding from the European Commission under the FP7-PEOPLE-2010-ITN project CATHI (Marie Curie Actions - ITN). Grant agreement no PITN-GA-2010-264330.

New electromagnets for HIE-ISOLDE: from conceptual design to magnetic compatibility studies (16)

Corresponding Author: Panagiotis.farantatos@cern.ch

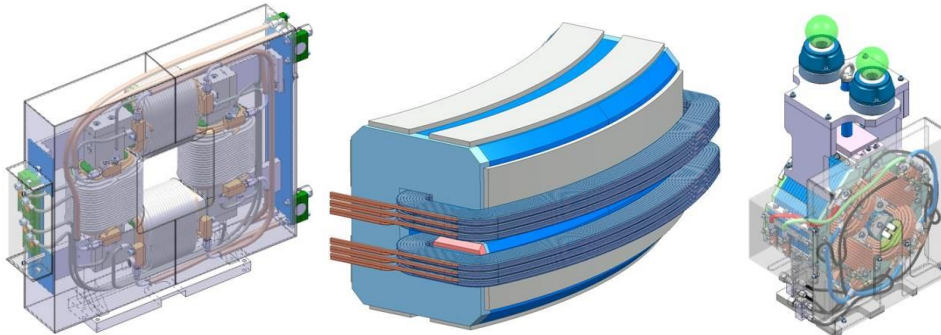

The HIE-ISOLDE high energy beam transfer lines shall contain 4 (+3 optionally) dipole electromagnets for switching and bending the beam towards 3 experimental stations, 24 (+8 optionally) quadrupole electromagnets for vertical and horizontal focusing of the beam and 20 dual plane correcting dipole electromagnets for beam trajectory correction.

The main engineering parameters of the electromagnets were translated from beam optics requirements as well as requirements defined by the vacuum system, power converters and cooling water network engineering interfaces. This consequently led to a detailed analytical design, where the excitation current, cooling parameters and detailed coil design of the electromagnets were defined.

These inputs led to an initial 2D magnet lamination mechanical profile design which allowed the elaboration of an advanced 3D magnetic model. Extensive Finite Element Analysis (FEA) and field quality harmonic analysis assessment led to a final mechanical geometry which yielded a magnetically optimal model. This optimum mechanical geometry obtained from magnetic modelling evolved in the detailed 3D manufacturing drawings which accompanied the technical specifications of the electromagnets for their procurement in industrial partners. The dipole and quadrupole electromagnets comprise laminated electrical steel yokes, while the correcting dipole electromagnets are made from solid iron yokes. All magnets comprise water-cooled hollow copper coils.

Furthermore, magnetic compatibility issues were raised due to electric machinery operating in close proximity to the magnets. In particular, a turbo-molecular pump and two stepping motors would operate under the stray magnetic field influence of the dual plane correcting dipole. In all cases FEA was used for estimating magnetic interference in the volume occupied by this machinery. In the case of the stepping motors, magnetic field interference was found to be low, while in the case of the turbo-molecular pump, the radial magnetic field component was found to be critically high. In the latter case, this could generate eddy currents and cause overheating, leading to perturbations during the nominal operational mode of the pump. Consequently, a cylindrical magnetic shielding design made of structural steel was proposed which assures safe operation of the turbo-molecular pump. This magnetic shielding design was magnetically analyzed using FEA in order to determine any potential dimensional sensitivity issues on the shielding quality and assess any potential impact on the dual plane corrector dipole's field quality. It remains to be integrated, provided that the turbo-molecular pump will keep its current position in the final machine layout.

Finally, in the framework of the CATHI project, a secondment project was initiated with the Danish Technical University, Department of Electrical Engineering (DTU – ELEK) which led to an on-going collaboration on the theoretical and experimental continuous torque performance assessment of permanent magnet couplings.

The research leading to these results has received funding from the European Commission under the FP7-PEOPLE-2010-ITN project CATHI (Marie Curie Actions - ITN). Grant agreement no PITN-GA-2010-264330.

TSR@ISOLDE (17)

Corresponding Author: Fredrik.wenander@cern.ch

The goal of the TSR@ISOLDE initiative is to place the Test Storage Ring (TSR) from MPI-K, Heidelberg, after the HIE-ISOLDE linac to perform experiments with stored exotic nuclides. With the integration of TSR at HIE-ISOLDE it would become the first storage ring at an isotope separator on-line facility. A substantial fraction of the vast number of radioactive beams produced at the ISOLDE facility could be injected into the ring for storage, beam deceleration or acceleration. Apart from decay studies, reaction studies could be carried out using an internal gas-jet being installed at the experimental section of the ring. The ions could also be extracted slowly to external setups by means of resonant excitation extraction.

TSR is a storage ring with a circumference of 55.42 m and a residual gas pressure in the 10^{-11} mbar region. The ions are introduced from the linear accelerator into the ring by multiturn injection. The length of the injection window is typically 30 μ s, meaning that the extraction time from the breeder should be shorter in order not to lose the exotic ions. An RF cavity compensates for the energy losses in the gas-jet target, and can in principle also be used for accelerating or decelerating the beam, although the process is slow and takes several seconds. The rigidity range of the ring stretches from 0.25 to 1.57 Tm, thus ions with 10 MeV/u should have a mass-to-charge ratio lower than 3.4. The ring features an electron cooler used for beam size and energy spread reduction. A transverse beam emittance, relative energy spread and beam size in the experimental interaction region of a few 10^{-2} μ m (normalized), few 10^{-5} and smaller than 1 mm (all 1σ) are expected for stored beam intensities below 10^8 ions.

As the electron cooling time is inversely proportional to the square of the ion charge, higher charge states out of the breeder are of interest. Likewise the ion storage time benefits from higher charges as the electron stripping cross-section is reduced. Finally, and most challenging, some of the experiments requests fully stripped ions, or Li/Na-like atomic configuration for the very heavy $A\sim 200$ ions. For these reasons an upgrade of the REXEBIS charge breeder, which can presently only provide fully stripped ions to $Z=20$, would be of interest. The results from the initial technical investigations of such an advanced breeder will be discussed.

The widely varying operational schemes will impose a large flexibility on the injector. For instance, the injection period will vary between 0.5 and 2 s, in some cases even longer times. The radioactive ions from ISOLDE will therefore have to be accumulated for an extensive time in REXTRAP before they are injected into the charge breeder. The implications of the long storage time in the Penning trap will be addressed.

The initiative at its present stage will be summarized, specifically the interfacing of the ring with the HIE-ISOLDE linac and HEBT, and a tentative layout of the ring and its experimental areas will be introduced. Results from the extensive integration study covering the technical aspects of the move and integration into the CERN accelerator environment will be presented, in addition to next steps and future prospects.

Brookhaven EBIS program: operation and development (18)

Corresponding Author: Alexander Pikin, pikin@bnl.gov

Co-authors: James G. Alessi, Edward N. Beebe, Andrey Shornikov, Roberto Mertzig, Fredrik Wenander, Richard Scrivens

Since its commissioning in September 2011 the Electron Beam Ion Source (EBIS) routinely supplies highly charged ions for the Relativistic Heavy Ion Collider (RHIC) and NASA Space Radiation Laboratory (NSRL). Normally RHIC EBIS operates with an electron current of 7 – 8 A and electron beam neutralization in the trap of 70 - 90%. There are three primary ion sources of singly charged ions for ion injection into EBIS trap, and one can switch between different species in a matter of 0.2 s using fast electrostatic optics. To date 16 ionic species have been delivered to users, from $^3\text{He}^{2+}$ to $^{238}\text{U}^{38+}$. Owing to its high reliability the beam availability from EBIS in 2014 was 99.8%. EBIS development includes expansion of its ion trap for higher beam intensity, upgrade of the electron collector to provide better vacuum, and the building of a Brillouin electron gun for generating a high-current-density electron beam. The purpose is to increase the ion charge state and thereby enabling higher ion energy from the Booster to NSRL, and to develop the technology for the new ISOLDE high intensity and high energy charge breeder. The simulation results and the design of new gun with electrostatic focusing are presented. The new electron gun is installed at Test EBIS and in first experiments an electron beam with a current up to 1.7 A was transmitted to the electron collector.

The research leading to these results has received funding from the European Commission under the FP7-PEOPLE-2010-ITN project CATHI (Marie Curie Actions - ITN). Grant agreement no PITN-GA-2010-264330.

Development progress of the charge breeder for HIE-ISOLDE and TSR@ISOLDE (19)

Corresponding Author: andrey.shornikov@cern.ch

Co-authors: Robert.mertzig@cern.ch, pikin@bnl.gov, Fredrik.wenander@cern.ch

As a part of the CATHI project, work package 8 “Radioactive Ion Beams Quality Improvements”, a design study of a new high-performance successor to the REXEBIS charge breeder has been carried out. In a parametric study based on the HIE-ISOLDE upgrade 2a scenario, and a possible future extension of HIE-ISOLDE by TSR@ISOLDE, a set of design requirements for the new breeder was elaborated. In collaboration with world-leading EBIS and EBIT groups the feasibility of the project was analyzed and the critical constraint was found to be a High Energy Compression and Current (HEC2) electron beam. Such beam is required to deliver the requested very high charge states and high repetition rate, while maintaining the ion pulse capacity and acceptance for primary ions. The HEC2 beam exceeds by far parameters of contemporary EBIS/T devices and requires significant R&D.

In collaboration with the Advanced Ion Sources group at Brookhaven National Lab a research program was initiated. Based on BNL development a high compression electron gun was built at CERN and shipped to BNL, commissioned, tested and brought to operation on a full scale TestEBIS. The electron beam was extracted from the gun, guided to full compression region, transported through the ionization region with comparable length to HIE-ISOLDE breeder and efficiently absorbed in the collector. The beam was transmitted in a magnetic field up to 3.3 T over about 4 meters distance. In these experiments we achieved an electron current up to 1.7 A and the electron energy was about 35 keV. This is a significant step towards the full HIE-ISOLDE specification of 3.5 A and about 60 keV (up to 150 keV for TSR@ISOLDE). We have identified potential sources of a 20 mA loss current limiting the achieved current to 1.7 A. At the moment, a series of design modifications is on the way to address and mitigate the limiting loss. The compression of the electron beam can be measured only indirectly by analyzing the charge state distribution of the charge bred ions after a certain exposure time to the electron beam. In a series of preliminary experiments the electron beam was used to ionize residual gas in the unbaked EBIS vacuum chamber. Such experiment does not allow obtaining precise numbers on the current density, however, an intensive ion pulse containing bare oxygen and carbon amongst other charge states was extracted after 16.6 ms of breeding with 0.45 A electron beam. When projected to higher full current this gives rather optimistic estimations of achievable compression level.

During the autumn of 2014 the experimental research is continued. We are preparing an upgraded electron gun with enhanced optics at BNL. At CERN we also prepare for the commissioning by building diagnostics tools to analyze the charge state distribution, energy distribution and emittance of the charge bred ions. Furthermore we continue the design studies by addressing the required modifications in order to allow changing the electron collector optics from immersed flow electron beams with 20-25% duty cycle to high compression beams of near 100% duty cycle.

In this presentation we would like to give a summary of the R&D on the upgrade of the HIE-ISOLDE charge breeder. We will present a revised parametric study, recent experimental results, nearest future experimental plans and longer a longer development perspective.

The research leading to these results has received funding from the European Commission under the FP7-PEOPLE-2010-ITN project CATHI (Marie Curie Actions - ITN). Grant agreement no PITN-GA-2010-264330.

Beam dynamics design studies for 10 MHz bunch frequency of post-accelerated RIBs at HIE-ISOLDE (20)

Corresponding Author: matthew.alexander.fraser@cern.ch

A ten-fold increase in the bunch spacing of post-accelerated radioactive ion beams has been requested by several research groups targeting experimental physics at HIE-ISOLDE. A bunch spacing of ~ 100 ns will permit the use of time-of-flight techniques for particle identification and background suppression. A design study has been carried out to assess the feasibility of providing such a time structure inside the framework of the HIE-ISOLDE linac upgrade. It is proposed to bunch externally into the existing REX-ISOLDE RFQ using a single-gap grid-less multi-harmonic buncher (MHB). The MHB will operate at a sub-harmonic frequency of 10.128 MHz in order to produce the required bunch spacing with minimal loss in transmission. Whilst using the optional bunching system transmissions as high as $\sim 80\%$ can be expected with $\sim 15\%$ of the beam populating the satellite bunches located between the 10 MHz bunches. A chopper structure located after the RFQ will be required to remove the satellite bunches from the bunch train such that the stringent specification of $<1\%$ for the background is met.

The proposed scheme for the 10 MHz bunch repetition frequency will be presented, its specification outlined and its performance assessed with beam dynamics simulations. The studies demanded a comprehensive modeling of the low energy section of REX from the EBIS ion source through the A/q-separator and the RFQ. The entire system was implemented in the TRACK [1] beam dynamics program representing a single end-to-end simulation using numerically computed 3D electromagnetic field maps of all active components, including the RFQ. The model proved useful designing the bunching system and specifying the constraints imposed by the existing accelerator infrastructure on the beam parameters that will be delivered by an upgraded EBIS. The design and optimization of the MHB structure will be briefly discussed, along with the results of RF error studies that assess the effect of jitter on the delivered beam quality. The opportunity to reduce the longitudinal emittance formed in the RFQ is also examined in different scenarios of the HIE-ISOLDE linac upgrade. An overview of the studies carried out for chopping the satellite bunches will also be given.

[1] TRACK, ANL: <http://www.phy.anl.gov/atlas/TRACK/>

*The author acknowledges co-funding by the European Commission as a Marie Curie action (Grant agreement PCOFUND-GA-2010-267194) within the Seventh Framework Programme for Research and Technological Development.

Target voltage modulator development for the On-Line Isotope Mass Separator, ISOLDE (21)

Corresponding Author: luis.manuel.dos.santos.redondo@cern.ch

Co-authors: J. Fernando Silva, H. Canacsinh, J. P. M. Mendes, T. Fowler

The aim of this work was to propose a new modulator topology for the existing On-Line Isotope Mass Separator, ISOLDE, target, based on the power semiconductor technology progress, in order to substitute the actual ISOLDE modulator system, located at the Proton-Synchrotron Booster (PSB) at CERN, for the future energy and intensity upgrade of the delivered radioactive ion beam.

The ISOLDE ion source is connected to a thick target, floating at 60 kV, which is periodically bombarded by a 1.4 GeV high intensity proton beam (up to $2\mu\text{A}$). The produced ions are then accelerated to 60 kV by a grounded extraction electrode, before being transported to the experimental area. The target and ion source, raised to full accelerating potential, must be held at a precise voltage with respect to a grounded extraction electrode to provide the necessary acceleration. If high mass resolution is required in the downstream separator it is extremely important that this accelerating voltage is exceptionally stable. However, the impacting proton beam intensively ionizes the surrounding air, which perturbs the accelerating voltage because it represents a significant additional load on the 60 kV power supply, PS. Hence, during the critical period when protons strike the target the accelerating voltage is discharge to zero. This is acceptable provided that the stable accelerating voltage is interrupted for less than 10 ms, so still allowing the detection of very short lifetime radioisotopes. During this period the beam is prevented from entering the separator. The actual modulator, based on a fixed parameters hard-tube switch resonant circuit with a transformer, restores the voltage close to its nominal value within 6 ms. This circuit topology is proven to satisfy the voltage recovery time and stability constraints for positive ion beams. In the future, the beam energy and intensity increase for the HIE-ISOLDE (High Intensity and Energy ISOLDE) will inevitably lead to degradation of the target modulators performance.

Hence, a new circuit concept for the ISOLDE pulse power modulator, which can provide the mandatory stability for the future demands, has been proposed. This includes the same 60 kV PS and various solid-state switches, with the aim of increasing the efficiency and flexibility for changing the circuit parameters considering the various operating conditions. During the first years of the project, the target requirements for the new modulator were defined, and two low voltage prototypes, up to <10 kV, consisting of two versions of the concept, have been assembled in Lisbon and successfully tested at CERN. In fact, experimental measurements at CERN with a static electrical equivalent load circuit gave a voltage recovery time <0.5 ms, and overshoot $<0.2\%$, considering different operating conditions. One of the circuits is based on a Marx voltage multiplier and the other uses solid state switches that hold-off the full operation conditions voltage. More recently, in order to increase the overall system efficiency, the circuit was modified to include energy recovery of the load target.

This work was possible considering the two teams of physics and engineers that are working in Lisbon and at CERN.

A new modulator system for HIE-ISOLDE (22)

Corresponding Author: roger.barlow@cern.ch

Until now the current ISOLDE modulator system has functioned well and has delivered constant precise voltage to the target systems. With the advent of the HIE-ISOLDE project and increasing load demand from new target materials a revised modulator system is required. One of the key difficulties encountered is strictly related to ionization effects around the target in air during and immediately after beam impact, producing excessive loading on the power supply which reduces the target voltage level and furthermore reduces the possibilities of extraction of short life-time isotopes. The target voltage is required to recover to its stable value within 10ms to ensure that short-lived isotopes are extracted. Because of the limited power output of the high precision power supply the recovery time cannot always be respected hence a modulation system is used in which the charge of the target capacitance is resonantly transferred to a buffer capacitor during the heaviest ionization period (few tens of ns after beam impact) and re-established $\sim 200\mu\text{s}$ later on the target capacitance. Additional complexity due to circuit losses requires the power supply to provide current for a further 6ms before full stable target voltage is obtained ($\pm 0.6\text{V}$). Most of these issues have been addressed with the past ISOLDE modulator; however, new technologies are now needed with better systems diagnostics to cater for the new beam energies involved at impact point and new target materials.

To mitigate the problem new circuit topologies have been conceived and developed. One promising development is a "Charge pump modulator". In this circuit a 400nF buffer capacitor and the target capacitance are charged to 60kV by a low power, high precision D.C. power supply (HVPS). Immediately prior to beam impact the HVPS is disconnected from the target and buffer capacitors using a 90kV rated semiconductor switch. During beam impact the target capacitance is rapidly discharged to $\sim 50\text{kV}$ after which the buffer capacitor, which is partially isolated from the beam impact ionization by virtue of a series-connected 2.2k Ω resistor, begins to re-establish voltage on the target. After 1ms a feedback loop controlling an auxiliary high voltage amplifier, which applies a voltage in series with the buffer capacitor, is switched in. This additional voltage brings the target voltage back to the required $\pm 0.6\text{V}$ tolerance within 5ms. Finally, when the target has recovered sufficient high impedance, the feedback loop is opened and the HVPS is re-connected to the target to maintain the stable 60kV voltage.

Technical studies for the HIE-ISOLDE frontend upgrade (23)

Corresponding Author: Jacobo.montano@cern.ch

For ISOLDE, frontend is defined as the machine responsible for hosting the target unit and for delivering the radioactive ion beams to the mass separators. The frontends are installed in high radiation environments and work under severe conditions with very limited maintenance. Furthermore, the intensity of the proton beam driven to the target will be increased five times after the HIE-ISOLDE upgrade. The consequently higher radiation levels will reduce the lifetime of the frontends or even produce a major failure of their systems. The most important effects of radiation are the material damage and the air ionization. The high voltage is one of the most affected systems by these effects provoking breakdowns. An upgrade of the frontend that assure its good performance during its whole lifetime is mandatory facing the upcoming increases of the radiation levels.

The frontend extraction system has been targeted to be replaced. The existing one consists in a ground electrode that is placed in work position (or retired from work position) every time a target unit is replaced. A new extraction system consisting in two fixed stage extraction has been prototyped and studied. It intends to remove some identified risk elements of the existing system: no mechanism, no dirty tip since replaced with every unit, custom electrode design for different ion sources. This new system has been characterized in the new ISOLDE off-line lab. In the framework of the HIE-ISOLDE Design Study, thermal measurements, air conductivity measurements and extraction performance measurements have been performed for the characterization of the prototyped extraction.

The research leading to these results has received funding from the European Commission under the FP7-PEOPLE-2010-ITN project CATHI (Marie Curie Actions - ITN). Grant agreement no PITN-GA-2010-264330.

Automatic tuning of complex beam-lines (24)

Corresponding Author: tim.giles@cern.ch

Beam-tuning is essential to the operation of any beamline, accelerator or isotope separator, but it is time-consuming and needs to be repeated often to maintain optimal performance. The machine-time devoted to setup may be reduced by simulating in advance the desired tune [2], but the success of this approach is variable. Irregular beamline designs, poor alignment, and limited knowledge of the mechanical layouts can adversely affect the success of any simulation. And certain devices, such as beam-coolers or charge-breeders, may be extremely difficult to simulate with any accuracy.

In this paper we side-step the problems associated with simulation and adopt an alternative approach. We take the statistical techniques used to optimise computer models [1][4][3] and apply them directly to the machine hardware. Our method can be applied to any equipment, so long as the “goodness” of the tune can be quantified - usually by the beam current at the end of the beamline.

The optimisation algorithm was tested on the REX-Isolde post-accelerator, which comprises a large number adjustable parameters, and includes a number of exotic devices in addition to conventional beamline elements. Initial results are on a par with the best and most experienced human operators. The method has the potential to reduce setup time and increase the time available for physics.

References

- [1] Robert G. Bland, The allocation of resources by linear programming, *Scientific American* 244 (1981), no. 6, 126 { 144.
- [2] Kyoko Makino and Martin Berz, *Cosy in_unity version 9*, Nuclear Instruments and Methods in Physics Research Section A: Accelerators, Spectrometers, Detectors and Associated Equipment 558 (2006), no. 1, 346 { 350.
- [3] W.H. Press, S.A. Teukolsky, W.T. Vetterling, and B.P. Flannery, *Numerical recipes 3rd edition: The art of scientific computing*, Cambridge University Press, 2007.
- [4] J.H. Wilkinson, C. Reinsch, and F.L. Bauer, *Linear algebra, Grundlehren der mathematischen Wissenschaften*, Springer-Verlag, 1971.

A multi-reflectron Time-of-Flight mass spectrometer (25)

Corresponding Author: martin.breitenfeldt@cern.ch

Since the Noble Prizes in 1989 for H. Dehmelt and W. Paul "for the development of ion trap technique" these devices have been brought to a wide range of applications. E.g. in the field of nuclear physics traps are used for accumulation of ion beams, for purification of ion ensembles and as mass spectrometers for exotic species. At the ISOLDE facility at CERN trap techniques have been applied and further developed over the last decades.

The ISOLTRAP collaboration has been exploring the nuclei chart in the last 25 years and contributed to the fields of fundamental, nuclear and astrophysics with mass measurements of a precision down to 10^{-9} . During this time it has been necessary to improve the setup in means of precision, sensitivity and cleaning abilities. A new tool has been implemented in the system to allow measurements, which otherwise would be limited or impossible due to short half-lives, low yields or a bad ion-of-interest to contamination ratio. This device is a Multi-Reflectron Time-of-Flight mass spectrometer (MR-ToF MS).

In this presentation the principle of the MR-ToF MS as an electrostatic trapping device will be discussed, then some limits and requirements for the application will be derived. Finally a scenario and recent results of the ISOLTRAP MR-ToF MS will be presented.

Design study for a new high resolution separator at ISOLDE (26)

Corresponding Author: Mathieu.augustin@cern.ch

Co-authors: T. Giles, J. Montano, M. Breitenfeldt, R. Catherall

In the framework of High Intensity and Energy (HIE)-ISOLDE project at CERN, the High Resolution Separator (HRS), one of the ISOLDE's mass spectrometer for the production of radioactive ion beams, will undergo major improvements. The new setup has to provide a mass resolving power of $R=m/\Delta m \sim 20\,000$ to allow suppression of contaminating nuclei for physics experiments and for radioprotection reasons. Following the constraints raised by the current beam line positioning and space availability in the existing separator room, new layouts are proposed and investigated with simulations. These layouts feature a pre-separator, a beam-cooler to improve the beam emittance, several electrostatic elements, beam diagnostics, and the separator magnet including higher order corrections.

Different magnet types were considered, and following the constraints previously mentioned and the results of simulations, this lead to the choice of plain pole face magnet, exhibiting a radially inhomogeneous field. The choice of the magnet type, its specifications and the technology of pole face windings used for the adjustment of a defocusing component and the correction of higher order terms is discussed as well.

In order to verify the principles necessary for the upgrade of the HRS before bringing modification to the machine, a new test stand (ISOLDE offline 2) has been commissioned. It consists of an ISOLDE Front End, a mass separator magnet, a beam-cooler, and electrostatic elements, making it very similar in its design to the current online facility. This new offline test stand will expand possibilities for research and development on the different items of the setup. Of special interest is a dipole magnet with pole face winding for the adjustment of quadrupole, sextupole and octopole terms. This magnet is currently under design and will contribute to validate the technology.

References

- [1] Hermann Wollnik, Optics of charged particles, Orlando, FL : Academic Press, 1987
- [2] Jack T. Tanabe, Iron Dominated Electromagnets : design, fabrication, assembly and measurements, Singapore, World Scientific, 2005
- [3] S. Russenschuck, Field Computation for Accelerator Magnets, Weinheim : Wiley, 2010

The research leading to these results has received funding from the European Commission under the FP7-PEOPLE-2010-ITN project CATHI (Marie Curie Actions - ITN). Grant agreement no PITN-GA-2010-264330.

Low level control for the HIE-ISOLDE high resolution separator magnet (27)

Corresponding Author: mark.butcher@cern.ch

In the framework of the High Intensity and Energy (HIE)-ISOLDE project at CERN the control system of the High Resolution Separator (HRS) has been upgraded.

Two approaches have been followed for the renovation of the magnet control: the first one is the updating of the previously used control system to the current BE-CO standard, in particular substituting the old GM infrastructure with the new object oriented front-end software framework (FESA). Operational results are shown.

The second one regards the development and implementation of a new low-level control algorithm. The HRS dipole magnetic field should in the future be controlled with an accuracy of a few ppm and with a faster response than the current one. In order to achieve these strict requirements a closed-loop control system is proposed, based on the Proportional Integral Derivative (PID) control architecture with a nonlinear compensator to compensate the magnetic hysteresis. An observer, developed using an accurate model of the magnet, is used in the feedback loop. It should be able to predict the magnetic field value using knowledge of the supply current read and, when available, the intermittent measurements of the magnetic field performed by a nuclear magnetic resonance (NMR) probe. Some simulation results will be shown.

The research leading to these results has received funding from the European Commission under the FP7-PEOPLE-2010-ITN project CATHI (Marie Curie Actions - ITN). Grant agreement no PITN-GA-2010-264330.

Improvements and future developments for the radio frequency quadrupole cooler and buncher at ISOLDE (28)

Corresponding Author: Carla.babcock@cern.ch

ISOLDE's radio frequency quadrupole cooler and buncher (RFQCB), called IS-COOL, is a helium-filled Paul trap located after the two High-Resolution Separator (HRS) magnets in the ISOLDE beam line, and is used to reduce the emittance of the beam while offering the option of creating a time structure (bunching). The RFQCB provides increased beam quality, and is relied on by all of the experiments using the HRS at this facility. Operating experience with this machine has shown, however, that improvements to the vacuum system, alignment and overall design are necessary for optimal performance.

The pressure inside the ion trap is unknown and, based on simulations and experiments may be too low by an order of magnitude, resulting in inefficient cooling within the available length. However, the helium flow into the ion trap is limited by the constraints of the low pressure that must be maintained in the rest of the beam line, and the helium flow itself is uncalibrated and irreproducible.

The alignment of the machine has been measured and a deviation of 0.75 mm has been found between the injection (and extraction) electrodes, necessitating dramatic beam steering during operation and lowering the acceptance of the machine. This has been resolved by the use of adjustable supports and the new alignment is accurate to within 0.1mm.

Apart from modifications to ISCOOL, upgrades to promote new RFQCB functionalities will be tested on a new machine that will be mounted on a test bench. These functionalities include adapters to allow laser light to illuminate the ion trapping region in order to facilitate experiments which require in-cooler pumping, and more diagnostics in order to monitor the internal helium pressure. This test bench will also allow the measurement of various parameters, such as emittance and transmission as a function of mass, which are currently not well known for ISCOOL and will be useful for its operation.

This talk will discuss the changes that have been made to ISOLDE's current RFQCB, the progress of the construction of a new RFQCB with the features mentioned above, as well as some possible design improvements for future machines.

The ESS superconducting Radio-Frequency linac activities and implementation (29)

Corresponding Author: Christine.darve@esss.se

The European Spallation Source (ESS) is a multi-disciplinary research centre under construction in Lund, Sweden. This new facility is funded by a collaboration of 17 European countries and is expected to be up to 30 times brighter than today's leading facilities and neutron sources. The ESS will enable new opportunities for researchers in the fields of life sciences, energy, environmental technology, cultural heritage and fundamental physics.

A 5 MW, 2.86 ms long pulse proton accelerator with a repetition frequency of 14 Hz (4 % duty cycle), and a beam current of 62.5 mA is used to reach this goal.

Three families of Superconducting Radio-Frequency (SRF) cavities are being prototyped, counting the spoke resonators with a geometric beta of 0.5, medium-beta elliptical cavities ($\beta_g=0.67$) and high-beta elliptical cavities ($\beta_g=0.86$).

The Niobium cavities and fundamental power couplers are assembled into cryomodules, which are operating using RF sources, cryogenic and water coolings. These cryomodules operate in a radioactive environment, at 2 K and at a frequency of 704.42 MHz.

Cavity cryomodule technology demonstrators will be built and tested by the end of 2016 in order to validate the ESS series production in industry.

The design, performance and integration of each SRF linac component benefit from technology and lessons learned from the worldwide SRF accelerator community.

RIB at TRIUMF: From ISAC to ARIEL (30)

Corresponding Author: Colin Morton, Morton@triumf.ca

ISAC, the Isotope Separator and Accelerator at TRIUMF, is an ISOL-type RIB facility that has been in operation since 1998. Like most such facilities, it has unique capabilities that differentiate it from others around the world. RIB production at ISAC is driven by 480–520 MeV protons from TRIUMF's main cyclotron at beam currents of up to 100 μA , giving ISAC the highest driver-beam power among existing facilities and allowing the routine delivery of beams with half-lives as short as a few milliseconds in quantities suitable for accelerated-beam experiments. ISAC also has a post-accelerator complex comprising a room-temperature RFQ and DTL and a superconducting heavy-ion linac that allows the delivery of accelerated RIB with energies from 150 keV/u to upwards of 6.5 MeV/u for ions with mass-to-charge ratios less than six (and to upwards of 11.5 MeV/u for those with mass-to-charge ratios less than three). The facility currently delivers more than 3,000 hours of RIB to experiments each year, supporting a broad research program at low and high energies across a number of disciplines including nuclear physics, nuclear astrophysics, materials science, and the life sciences.

ARIEL, the Advanced Rare IsotopE Laboratory, will build on the existing ISAC facility to ultimately triple the number of hours of beam available for experiments while providing a complementary means of RIB production. The centrepiece of ARIEL is a new superconducting electron linac, one of the world's most advanced, that will serve as a high-power driver for RIB production by photofission of actinide targets using bremsstrahlung photons from the stopping of high-energy electrons in a thick converter target. This is expected to produce high-intensity beams of very neutron-rich isotopes at intermediate masses without the heavy, alpha-particle-emitting spallation products associated with proton-driven production. A second high-current proton beamline will be used to drive RIB production by spallation as at ISAC in order to serve high-precision experiments requiring long running times that cannot presently be accommodated. These will both operate in parallel with the existing ISAC production targets, allowing up to three RIB to be delivered to experiments simultaneously.

The first stage of ARIEL, colloquially known as ARIEL-I, comprises the e-linac and a new building to house the ARIEL target facilities. The building was completed in 2013 while the e-linac is undergoing commissioning for completion later this year. The second stage, ARIEL-II, will include high-power target stations, an upgrade of the e-linac to its full beam power, the second proton beamline, and low-energy beam transport from the ARIEL target stations to the existing experimental infrastructure at ISAC. This will be carried out in five phases interleaved with RIB production in support of TRIUMF's ongoing research program. Details of the entire ARIEL project, including a timeline of the project phases and the expected capabilities at each, as well as a review of TRIUMF's existing capabilities at ISAC will be presented.

SEPS: a being built exotic beam facility at INFN-LNL (31)

Corresponding Author: Giovanni.bisoffi@lnl.infn.it

INFN-LNL is constructing an ISOL facility delivering neutron rich ion beams at 10A MeV or beyond, making use of the linear accelerator ALPI as the secondary accelerator. The facility includes a direct ISOL target based on UCx and able to reach 10^{13} Fission/s. In parallel, an applied physics facility will be developed, with applications in medicine and neutron production.

Considering the exotic beam application, SPES is developed under the NuPECC umbrella, together with HIE-Isolde at CERN and Spiral2 at GANIL, as a second generation Exotic Beam Facility paving the way to EURISOL. The SPES project is a national facility, which was approved for construction and is being financed in stages. SPES enjoys fruitful collaborations with Italian labs and Universities, European and extra-European labs. Commissioning with the first exotic species is expected in 2018.

The primary accelerator is a commercial cyclotron, which will send a 40 MeV, 200 uA proton beam onto a UCx target, connected to SIS, PIS and LIS ion sources. The extracted beam is purified through a Low Resolution Mass Separator (LMRS, Wien filter and a dispersive dipole), a beam cooler and a High Resolution Mass Separator (HRMS) and sent to an ECR Charge Breeder to boost the exotic beam charge state. The highly charged exotic beam is further separated in a MRMS (Medium Resolution Mass Separator) and injected into a 100% duty cycle RFQ and into the existing superconducting linac ALPI, which will be refurbished and upgraded to be an efficient exotic beam accelerator. The upgrade is tuned, so as to give ~ 10 MeV/A specific energy to ^{132}Sn , taken as the reference ion beam.

At present, the cyclotron accelerator is approaching completion, together with the building hosting it (<http://www.lnl.infn.it/index.php/en/>). After cyclotron commissioning, the second part of the machine which will become operational will be the one from the charge breeder to the RFQ injection, through the MRMS (phase planned in 2016). By the time of completion of the RFQ construction, the beam line from the Target-Ion-Source to the Charge Breeder, and the new ALPI injector will be completed too, and commissioning of the whole facility will start in stages.

The research leading to these results has received funding from the European Commission under the FP7-PEOPLE-2010-ITN project CATHI (Marie Curie Actions - ITN). Grant agreement no PITN-GA-2010-264330.

ECOS-LINCE: A proposal for a high-intensity stable-beam facility for nuclear structure and reactions (32)

Corresponding Author: ismael.martel@gmail.com

During the last decades there have been extraordinary advances in our knowledge of the fundamental physics governing the relevant subatomic degrees of freedom, from atomic and plasma physics to basic nuclear structure and reactions. Many of these achievements have been addressed by the use of both stable and radioactive beam facilities. However, new physics paradigms have emerged together with a number of research programs, requiring a new heavy-ion facility able to provide higher intensity stable heavy-ion beams and/or where measurements requiring long periods of beamtime could be realized. The ECOS collaboration [1], an expert working group of NuPECC, strongly supported the construction of a dedicated high-intensity stable-ionbeam facility in Europe with energies at and above the Coulomb barrier, to be considered as part of the next Long-Range Plan of the Nuclear Physics community.

In order to fulfil the ECOS physics program we propose to build a superconducting (SC) heavy ion linac. The required intensities should be of 1 mA for protons and light ions, and in the range of 10 μA to 100 μA for heavy ions. A sample of relevant beams, energies and intensities are listed in Table 1.

Table 1: Selected Beam Intensities and Energies

Ion	Q	A/q	E (Mev/u)	I (μA) / I ($\text{e}\mu\text{A}$)
H	1	1	45	1000 / 1000
^4He	2	2	10	500 / 1000
^{28}Si	9	3.1	12	10 / 90
^{48}Ca	8 or 10	6 or 5	7.5	10 / 80 or 100
^{184}W	27	6.8	2.5	1 / 27
^{238}U	34	7	8.5	0.5 / 17

The proposed ECOS-LINCE heavy-ion linac [2] should take advantage of the developments already carried out for the construction of SPIRAL2, ATLAS and FRIB facilities. It has been designed to accelerate $A/Q = 1 - 7$ ions from 500 keV/u as delivered by a four-vane RFQ [3], to about 8.5 MeV/u, using 26 SC QWRs and 15 SC solenoids. The RF frequencies used for the resonators are harmonics of 18.19 MHz, the fundamental frequency for the LINCE Project.

References

- [1] F. Azaiez et al., <http://www.nupecc.org/ecos/ECOS-Final.pdf>
- [2] I. Martel et al., THPME036, Conf. Proc. IPAC2014, Dresden (Germany).
- [3] A.K.Orduz et al., THPME037, Conf. Proc. IPAC2014, Dresden (Germany).

Overview of ISOL facility at RISP (33)

Corresponding Author: Hyung-Joo Woo, hjwoo@ibs.re.kr

Rare Isotope Science Project (RISP) is in progress for the construction of world-class Rare Isotope Facility in Korea. The key feature of ISOL facility at RISP is to provide high intensity and high-quality beams of neutron-rich isotopes with mass in the range 80-160 by means of 70 MeV proton beam directly impinging on uranium carbide thin-disc targets to perform forefront researches in nuclear structure, nuclear astrophysics, reaction dynamics and interdisciplinary fields like medical, biological and material sciences. The technical design of the 10 kW direct fission target with in-target fission rate of up to 2×10^{13} fissions/s has been performed, and for the development of ISOL fission target chemistry initial effort has been given to the production of porous lanthanum carbide (LaCx) disc as a benchmark for the final production of porous UCx disc. To produce the large part of the possible beams, three classes of ion source are under development at RISP: the surface ion source, the plasma ion source (FEBIAD), the laser ion source, and the prototype fabrication is in progress. An engineering design and fabrication of ISOL target/ion source front-end system is also in progress, and a prototype will be used as off-line test facility in front of the pre-separator. The technical designs of other basic elements in ISOL facility such as the RF-cooler, the high-resolution mass separator, the A/q separator have been almost finished, and the results are introduced with the following plans.

The SPIRAL 2 – GANIL facility: the technical developments made for the highly intensive radioactive ion beams from ISOL production (34)

Corresponding Author: hanna.franberg@ganil.fr

The SPIRAL 2 facility at GANIL is under installation and will begin to produce beam in the end of 2014.

The facility is constructed to perform experiments on radioactive ion beams of high intensities from both in-flight and ISOL production stations. The stable beams produced and accelerated will in the first years be used in the S3 and NFS facilities also constructed at site.

Later on the stable beams will be used in a unique production building for the production of highly intensive RI beams through ISOL production.

The current beams from GANIL, and those under development, will also be used in a new experimental area that is to be constructed on the GANIL site. Giving the experimental installations a larger choice of the radioactive ion beams to be investigated.

A general presentation of the installation will be made with a focus on the technical developments made to handle the production of the highly intensive radioactive ion beams around the ISOL production station. I will present the technical developments made for the maintenance and operation of the production station and the beam lines up to the experimental points.

CERN-MEDICIS: a new facility (35)

Corresponding Author: thierry.stora@cern.ch

About 50% of the 1.4 GeV CERN (European Organization for Nuclear Research, www.cern.ch) protons are sent onto targets to produce radioactive beams by online mass separation at the Isotope Separator Online Device (ISOLDE) facility, for a wide range of studies in fundamental and applied physics. CERN-MEDICIS is a spin-off dedicated to R&D in life sciences and medical applications. It is located in an extension of the Class A building presently under construction. It will comprise laboratories to receive the irradiated targets from a new station located at the dump position behind the ISOLDE production targets. An increasing range of innovative isotopes will thus progressively become accessible from the start-up of the facility in 2015 onward; for fundamental studies in cancer research, for new imaging and therapy protocols in cell and animal models and for pre-clinical trials, possibly extended to specific early phase clinical studies up to Phase I trials. Five hundred megabecquerel isotope batches purified by electromagnetic mass separation combined with chemical methods will be collected on a weekly basis. A possible future upgrade with gigabecquerel pharmaceutical-grade *i.e.*, current good manufacturing practices (cGMP) batch production capabilities is finally presented.

The ISOL@MYRRHA project (36)

Corresponding Author: Lucia Popescu, lpopescu@sckcen.be

One of the major projects under development at SCK•CEN, is MYRRHA: a Multipurpose hYbrid Research Reactor for High-tech Applications. MYRRHA is an accelerator driven system (ADS), which combines a subcritical nuclear reactor, a spallation target and a high-power linac. Neutrons produced by spallation at the impact of the proton beam on the Lead-Bismuth Eutectic (LBE) target are feeding the subcritical core of the reactor, which, otherwise, would not be able to keep the chain reaction. The system is designed to run both in subcritical and critical modes, when the accelerator is decoupled from the reactor core and the core configuration is changed to reach criticality.

The applications catalogue of this facility is vast and runs over many fields of science and technology development. An important application of MYRRHA is the production of Radioactive Ion Beams (RIBs) for fundamental science and nuclear medicine. For this, part of the proton beam delivered by the accelerator is directed towards an Isotope Separation On-Line (ISOL) system that operates in parallel to the sub-critical reactor. This system, called ISOL@MYRRHA, aims at producing RIBs with unprecedented intensities. 600-MeV protons (and, in a second phase of the project, 1-GeV protons) with beam currents of up to 0.2 mA, are going to be used for RIB production. This makes out of ISOL@MYRRHA a next-generation ISOL facility.

The presentation will give an overview of the envisaged ISOL@MYRRHA facility, underlining the technical challenges and related R&D activities.

Extending the scope of the ISOLDE Laser Ion Source (37)

Corresponding Author: Sebastien.rothe@cern.ch

Starting as an experiment at ISOLDE the resonance ionization laser ion source RILIS has now developed into one of the most often selected methods to ionize the isotopes requested by the facility users. One main reason is the high degree of selectivity of ionizing only a single element of choice. This gives rise to a selective enhancement over possible contaminants. Besides its standard operation as an ion source, the RILIS is also frequently used for in-source laser spectroscopy to determine isotope shifts and hyperfine structures of the atomic spectrum which allow the extraction of nuclear structure properties. These investigations directly benefit many users, since the precise laser frequencies are then known for certain isotopes and in some cases the ratio of isomer to ground state within the resulting beam of a chosen isotope can be influenced.

In the framework of the HIE-ISOLDE proposal formulated in 2006 the RILIS laser system underwent a series of upgrades: The copper vapor lasers were replaced by solid-state high average power lasers, the dye laser system now comprises commercial lasers, a complementary solid-state titanium: sapphire laser system was installed and the beam transport and instrumentation was improved. The remote control and monitoring of RILIS parameters is essential for the immediate goal of operating the system from the new RILIS control room, away from the environment with an elevated level of radiation. This will, in the mid-term, allow for switching to on-call RILIS operation.

Besides the operation of RILIS (and especially during LS1), the team has been pursuing an ongoing program of RILIS development: New, more efficient laser ionization schemes have been determined, techniques to exploit the pulsed nature of the laser ion beam have been investigated and a compact atomic beam unit to be used for reference measurements during in-source laser spectroscopy experiments was commissioned. A permanent laser installation at the new ISOLDE off-line separator will advance these developments further, but will also give the possibility to verify the compatibility of new mass-separator geometries that have been developed as part of the CATHI programme with RILIS.

In this presentation, the RILIS workings will be introduced, followed by an overview of the upgrade sequence and the current status and capabilities. In the second part the ongoing developments and basic studies to enhance the RILIS performance, conducted mainly during LS1, will be highlighted and the prospects for their future implementation at HIE-ISOLDE will be described.

Target area infrastructure, cooling and ventilation (38)

Corresponding Author: andrea.polato@cern.ch

The upgrade of the proton beam in intensity (from $2\mu\text{A}$ to $6.7\mu\text{A}$) and energy (from 1.4 GeV to 2 GeV) will cause an increase in the contamination of the air present in the ISOLDE Tunnel.

The Design Study constituted a good occasion to study a set of practical solutions to limit the activity releases into the environment via the:

- Stop of the air supply during beam mode;
- Reduction of the ISOLDE Tunnel negative pressure with respect to the outdoors;
- Increase of the leaktightness of the tunnel;
- Installation of leak tight doors;

Part of the activity has been devoted to the study of measures in order to separate the ventilation systems of the HIE ISOLDE Tunnel from the adjacent Class A Laboratory, in particular with the installation of airlock chambers between HIE ISOLDE Tunnel and Class A Laboratory.

Concerning the heat removal system, the activity was focused in the integration of the target cooling system into the cooling towers loop that has been installed for the whole ISOLDE facility.

The presentation will show the different steps of the Design Study from the first assumptions and on field measurements to the final proposals.

Radiation related estimations near ISOLDE tunnel with FLUKA (39)

Corresponding Author: Leonel.morejon@cern.ch

Co-authors: V. Vlachoudis, J. Vollaire, Th. Stora, A. Dorsival

In the ISOLDE facility, beams of rare isotopes are prepared for dedicated nuclear physics experiments. In the initial stage 1.4 GeV protons at 2.0 uA are directed towards heavy targets (U, Ta, W) to produce the desired isotopes. This occurs in the ISOLDE tunnel, where high neutron fluxes are produced as result, with an Energy spectrum similar to the one shown in the Figure below.

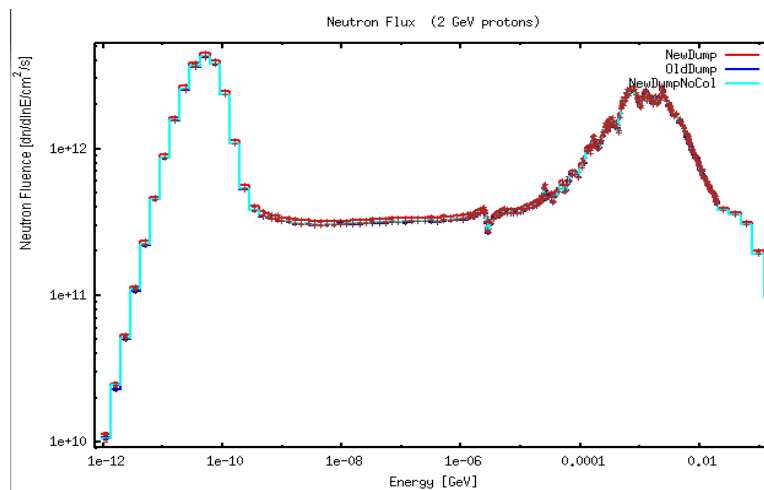

Figure: Neutron flux inside the ISOLDE tunnel (from beam dump studies).

The HIE-ISOLDE upgrade foresees an increase of this flux due to an increase of the proton beam Intensity to 7uA and Energy to 2.0GeV. This calls for a review of the beam dumps, shielding and activation inside the tunnel.

On the other hand, the addition of a laboratory for medical applications (MEDICIS) and a new storage for the hot irradiated targets very close to the ISOLDE tunnel needed the estimation of dose and proposals of shielding.

The present work presents these studies, which have been performed with FLUKA simulations:

- As part of an evaluation of the beam dumps performance under HIE-ISOLDE conditions, Energy deposition profiles were calculated. Also for the study of a modification of the HRS beam dump, this was found to be needed.
- The dose affecting the MEDICIS and the target's storage was assessed for different configurations, obtaining separate results for the neutrons coming from the tunnel, the activated targets, and the activation of the shielding.
- The inclusion of new elements inside the tunnel (new robot rails, Fe-rich shielding) would activate as well. These results are also presented here.
- Finally, the results presented are benchmarked by comparing FLUKA simulations results with previous measurements performed on-site at ISOLDE.

The research leading to these results has received funding from the European Commission under the FP7-PEOPLE-2010-ITN project CATHI (Marie Curie Actions - ITN). Grant agreement no PITN-GA-2010-264330.

ISOLDE HRS and GPS dumps: evaluation of present and future operation (40)

Corresponding Author: valentina.venturi@cern.ch

The ISOLDE facility at CERN is operating since 1992. The two dumps, designed for an 800 MeV beam operating on HRS and GPS separators, have never been modified since then. The beam power, on the other hand, was increased up to 1.4 GeV.

With the further upgrade of the primary beam to 2.0 GeV foreseen after the second long shutdown at CERN, a study on the thermo-mechanical situation of the two actual dumps has been carried out.

The thermo-mechanical model is based on 2D drawings from the first project where the dumps are described as two structural steel blocks surrounded by concrete. No detailed information was found about the materials. Being not clear which is the actual contact state between the core and the shielding, a full range of possibilities was taken into account, by considering different thermal exchange rates.

After having studied the impossibility of a beam upgrade to 2.0 GeV without the risk of the dumps failure, a new design was considered. The proposal solution includes a water cooled Copper alloy block placed in front of the actual dumps allowing for lower temperature and stresses on the old steel cores. The possible HRS dump configuration is studied by means of CFD and FEM.

Recent results on the development of the SPES target-ion source complex (41)

Corresponding Author: alberto.andrighetto@lnl.infn.it

The SPES project at Laboratori di Legnaro of INFN (Italy), now in the construction phase, is concentrating on the production of neutron-rich radioactive nuclei by the Uranium fission at a rate of 10^{13} fission/s. The emphasis to neutron-rich isotopes is justified by the fact that this vast territory has been little explored, at exceptions of some decay and in-beam spectroscopy following fission.

The Rare Ion Beam (RIB) will be produced by ISOL technique using the proton induced fission on a Direct Target of UCx.

The most critical element of the SPES project is the Multi-Foil Direct Target. Up to day the proposed target represents an innovation in term of capability to sustain the primary beam power. The design is carefully oriented to optimise the radiative cooling taking advantage of the high operating temperature of 2000°C.

During the talk will be presented the recent developments on the fabrication, characterization, and on-line testing of uranium carbide targets. Also developments related to the ion-source activities using the surface ion source, plasma ion source, laser ion source techniques it will be reported. Finally test e results on handling of the target system it will be shown.

ESR9: target conceptual design (42)

Corresponding Author: Stefano.marzari@cern.ch

Co-author: S. Cimmino

This work package was held by Serena Cimmino during just over two years due to a late start in February 2012 and early departure in June 2014. Serena's work was focused on thermal issues and target development in order to optimise and improve thermal measurement quality, repeatability, safety and radioactive waste reduction. In addition she has contributed to the development of a new "donut" neutron converter in collaboration with TRIUMF laboratory in Vancouver and also to the new molten salt target tested at Isolde.

The research leading to these results has received funding from the European Commission under the FP7-PEOPLE-2010-ITN project CATHI (Marie Curie Actions - ITN). Grant agreement no PITN-GA-2010-264330.

Study of prototype refractory ceramics (SiC and Al₂O₃) with open unidirectional porosity (43)

Corresponding Author: Michal.czapski@cern.ch

Co-authors: T. Stora, R. Santos Augusto, C. Tardivat, S. Delille, J. Leloup, F. Bouville, R. Fernandes Luis

The goal of this study is to develop new prototype target materials for HIE-ISOLDE experiment, made of refractory ceramics (SiC, Al₂O₃) with an open uni-directional porosity for the HIE-ISOLDE project. It was shown before [1] that microstructure modification could impact effusive and diffusive properties of a material. By applying so-called *Ice-templating method* [2-3], which allows one to control pore formation conditions within the material, we prepared prototypes that showed an open uniaxial porosity of defined pore size and fraction. Those prototypes were later irradiated at CERN using the ISOLDE proton beam from the PS-Booster and the HiRadMat proton beam from the SPS to verify their aging due to irradiation. In this study, we assessed how the structure modification impacted effusivity and mechanical properties of the studied prototypes as well as their mechanical integrity due to impact of a proton beam. We also showed the first post-irradiation results.

References

1. S. Fernandes, "Submicro- and Nano-Structured Porous Materials for Production of High-Intensity Exotic Radioactive Ion Beams", EPFL, Switzerland, 2010
2. S. Deville, "Freeze-Casting of Porous Ceramics: A Review of Current Achievements and Issues", *Advanced Engineering Materials* 10 (3) (2008) 155169.
3. S. Deville, E. Saiz, A.P. Tomsia, "Ice-templated porous alumina structures", *Acta Materialia* 55 (6) (2007) 19651974.
4. S. Deville, C. Viazzi, J. Leloup, A. Lasalle, C. Guizard, E. Maire, J. Adrien, L. Gremillard, "Ice shaping properties, similar to that of anti-freeze proteins, of a zirconium acetate complex", *PloS one* 6 (10) (2011) e26474.

The research leading to these results has received funding from the European Commission under the FP7-PEOPLE-2010-ITN project CATHI (Marie Curie Actions - ITN). Grant agreement no PITN-GA-2010-264330.

Radiation protection study for the HIE-ISOLDE project (44)

Corresponding Author: Joachim.vollaire@cern.ch

Co-authors: S. Giron, A-P. Bernardes, A. Dorsival, D. Voulot

The presentation gives an overview of the Radiation Protection analysis performed for the upgrade of the existing Radioactive ion beam Experiment (REX) at ISOLDE with a superconducting linac. The new linac will raise the energy of the post-accelerated beams from 3 MeV/u to over 10 MeV/u in order to further expand the physics program conducted in the ISOLDE facility. From a radiation protection point of view, field emission in the superconducting quarter wave resonators and the associated dose rate due to X-rays as well as the possibility to induce nuclear reactions with beam energies above the Coulomb barrier are the two new aspects which have been considered in the analysis. The radiological risks due to the X-ray dose rate is mitigated by enclosing the accelerating part of the facility inside a shielding enclosure with personnel access interlocked to the RF power in the cavities. The thickness of the shielding has been determined by performing measurement on cavities during conditioning and quality factor measurement periods inside a test bench in a first step. In a second step, the measurement results were used as the source term of a FLUKA calculation for which a detailed model of the post-accelerator enclosure was implemented as a FLUKA geometry. The equivalent dose rate due to nuclear reactions with beam energies above the Coulomb barrier was evaluated considering the intensity of the post-accelerated beams and it was concluded that stable beams used for tuning the accelerator represented the envelope case. In collaboration with the operating team, the maximum allowed beam intensity corresponding to the different ion species which can be accelerated was determined considering the radiological classification of the area. Other radiological hazards already existing in the current facility as the contamination of the vacuum system which is inherent to the pumping of radioactive beam systems as well as the possibility to accumulate strong gamma emitters and create “hot-spots” will further increase with higher beam intensities and new experiment involving long half-lives radionuclides. Those changes were considered in the upgrade of the radiation monitor network which occurred in 2014 and additional monitors have been installed in order to anticipate the future radiological situation in the ISOLDE experimental hall.

The research leading to these results has received funding from the European Commission under the FP7-PEOPLE-2010-ITN project CATHI (Marie Curie Actions - ITN). Grant agreement no PITN-GA-2010-264330.

Vaccum: use of dry pumps and filters to avoid propagation (45)

Corresponding Author: Mario.armin.hermann@cern.ch; giovanna.vandoni@cern.ch

Within the framework of the Target area and Beam Quality improvement for the Design Study, the RFQ Cooler and Buncher was redesigned for larger acceptance and more cooling efficiency. An essential part of this study consisted in redesigning the vacuum system of the RFQCB. A molecular flow Monte-Carlo model was first benchmarked on the existing RFQCB. Orifice flow from the central quadrupolar electrode was modelled by I.Graur at University of Marseille and used as source term for helium flow in the UHV part of the section. New, optimized turbopumps, relying on the magnetic bearing technology, were installed on the new RFQCB and commissioned.

The present Gas Recuperation System of Isolde suffers from several safety issues, amongst which the most critical one is related to propagation of contaminant species along the vacuum pipework and through the primary pumps to two tanks operated in overpressure. The oil sealed primary pumps retain a part of the contaminants, thus filtering the effluent gases. Pump's maintenance, performed every two years, presents considerable risk of contamination of personnel and generates 70l of contaminated oil. A dry pump scheme with selective filtering on solid absorbers has been successfully tested during highly contaminating runs. The study of propagation of contaminants is being completed by a coupled numerical (Monte-Carlo) and experimental study. Collaboration with GANIL, INFN-Legnaro and INFN-Catania has focussed on parallel safety reviewing of the Gas Recuperation Systems for Spiral2 (Caen), SPES (Legnaro) and Tandem (Catania), steered from the TE/VSC group at CERN.

In the framework of the protection of the HIE-Isolde superconducting linac against air inrush, a test bench for leak propagation velocity was set up in collaboration with GANIL. Numerical simulation in the viscous and molecular regime is thus benchmarked by the pressure front propagation measurements performed with fast cold-cathode gauges and strain gauges.

The research leading to these results has received funding from the European Commission under the FP7-PEOPLE-2010-ITN project CATHI (Marie Curie Actions - ITN). Grant agreement no PITN-GA-2010-264330.

Evaluation of a potential explosive front-end (46)

Corresponding Author: ana-paula.bernardes@cern.ch

Co-authors: B. Crepieux, M. Czapski, R. Guida, L. P. De Menezes, H. Encontre, S. Marzari, N-T. Vuong

The On-Line Isotope Mass Separator ISOLDE is a facility dedicated to the production of a large variety of radioactive ion beams for a great number of different experiments. At ISOLDE, radioactive nuclides are produced in thick high-temperature targets via spallation, fission or fragmentation reactions. The targets are placed in the external proton beam of the PS Booster, which has an energy of 1.4 GeV and an intensity of about 2 μA . During operations ISOLDE targets are heated to high temperature (2000°C) under vacuum. The temperature is controlled by a water cooling system.

A leak on the cooling water target during operation could produce a large amount of gases, an increase of pressure, and in some case, could produce some explosive gases, such as hydrogen, by chemical reaction. All this gas production, in the better case could stay trapped inside the target and Front-end volume (cf. Figure 1) but in the worst case could leak outside the Front-end and produce an explosive atmosphere inside the faraday cage where the Front-end is located.

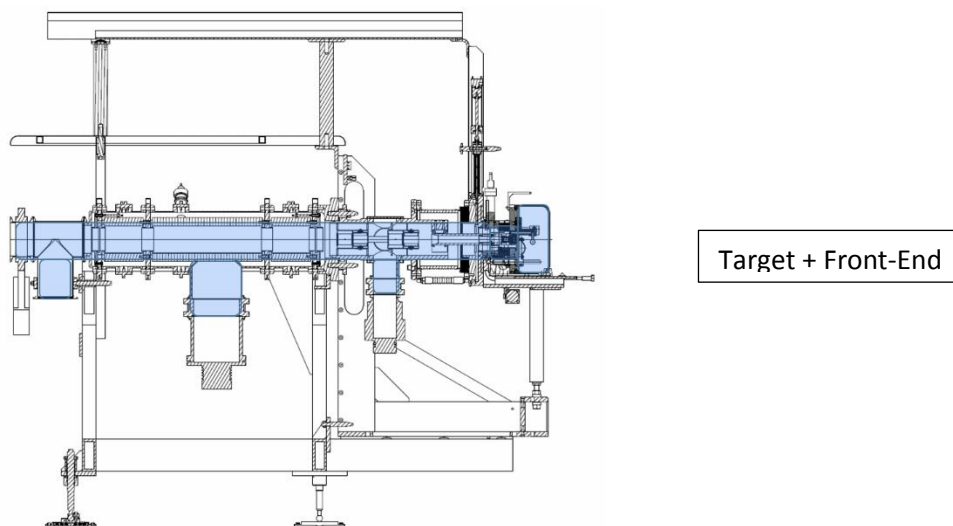

Figure 1 –Volume of the system filled with water vapour in blue

In order to assess the consequence of such a scenario, a test bench has been assembled to reproduce the condition of a water leak in a hot target during operation. In total three water leaks have been simulated. This talk will summarize the main lessons learned from these tests.

CATHI Final Review Meeting

22th-26th September 2014

Hotel H10 Marina, Barcelona, Spain



Local CERN Organizing Committee:

Yacine Kadi (Chairman)

Richard Catherall (Chairman)

Michal Czapski

Francoise Girard Madoux

Geraldine Jean

Ayse Karatepe

Merethe Morer-Olafsen

Annelie Rasmussen

CERN Scientific Advisory Committee:

Richard Catherall

Maria Garcia Borge

Thierry Stora

Walter Venturini Delsolaro

Fredrik Wenander

Didier Voulot

Thomas Otto

More information at:

indico.cern.ch/e/Cathi-Final-Review-Meeting

and

en-dep.workshops@cern.ch

