

# Induction session: physics coordination overview

1st CMS Induction Session - 18/7/2014

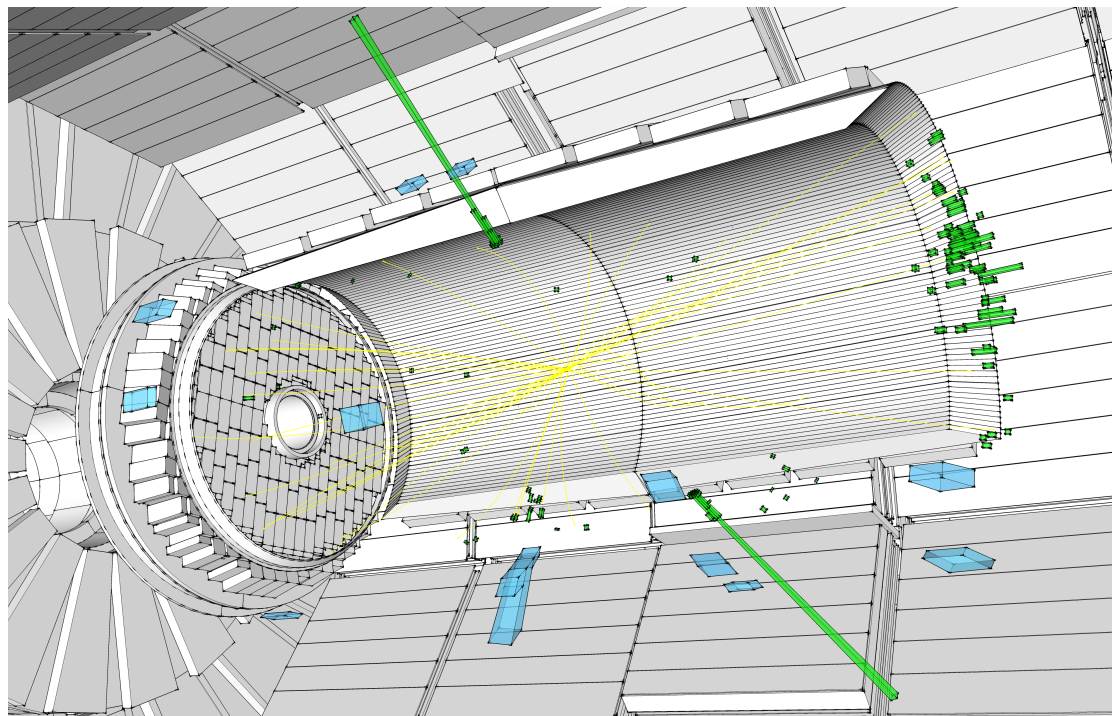

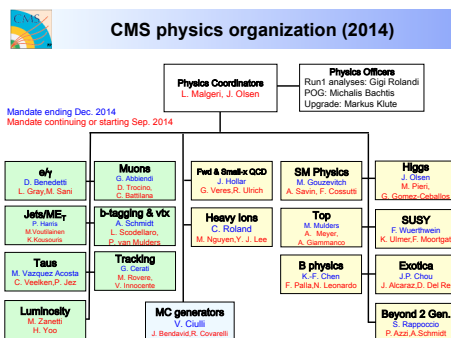

## Physics Coordination organization

- POGs, PAGs definition
- work organization
- documentation

## CMS product: publications

- the story of a physics analysis
- type of documents
- tools (CADI, CDS, etc.)
- publication committee

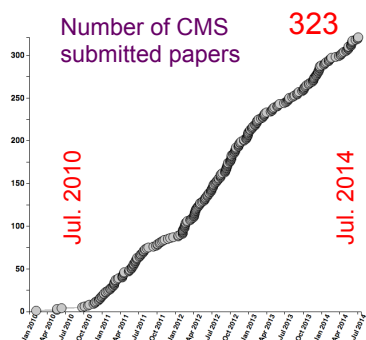

## First steps in a physics analysis

- how to produce the first plot
- how to access the data
  - (PAT, CRAB, Analysis Releases)
- statistical interpretation and statistics committee

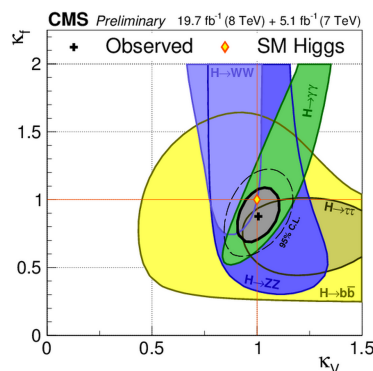

## Run2 physics highlights



# Physics Coordination organization

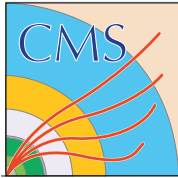

# What is Physics Coordination in CMS



Just a clarification on what we mean by “Physics Coordination” in CMS:

it is not the only place where we do **physics**, indeed everything you have seen here (from detector construction up to analysis) IS experimental particle “Physics”.

For a lack of better name in CMS (and in this talk) we call “Physics” (or better Physics Coordination) what is left at the end of the food chain:

physics object performance groups (**POGs**) and physics analyses groups (**PAGs**).

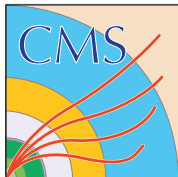

# What is Physics Coordination in CMS



First stop for documentation:

<https://cms.web.cern.ch/org/cms-collaboration>

The screenshot shows the CMS Collaboration website interface. At the top left is the CMS logo with the text "Compact Muon Solenoid experiment at CERN's LHC". To the right, it says "Logged in as malgeri Logout" and has a search box. Below the logo are two tabs: "PUBLIC WEBSITE" and "COLLABORATION WEBSITE". A navigation bar contains links for "Collaboration", "Coordination Tasks", "Detectors", "Upgrades", "Physics", "Meetings", "Documents", "Tools", and "Help". The "Physics" menu is open, showing three columns of links: "Coordination" (Physics Home page, Physics Results, LHC Physics Centre, Procedures & Guidelines, Analysis Tools, Generators, Statistics Committee, Physics Perf. and Dataset), "Analysis Groups" (Beyond 2 Generations, B Physics, Exotica, Forward Physics, Heavy Ions, Higgs, Standard Model, SUSY, TOP), and "Physics Objects" (B-Tagging, Tracking, e/gamma, Jets/MissET, Luminosity, Muons, Tau-ID). Below the navigation bar, there are "View" and "Revisions" buttons, followed by the text "Welcome to the CMS Collaboration (Internal) Website". A section titled "Upcoming meetings" lists several events for Friday, July 11, 2014, at 15:00. A graph titled "CMS Integrated Luminosity" shows a cumulative plot of luminosity over time, with a yellow area under the curve and a blue line representing the recorded luminosity. The graph indicates "CMS Recorded: 21.79 fb<sup>-1</sup>". On the right side of the page, there is a sidebar with links for "Indico category, search it", "At Work", "Group Calendar", "Hypernews", "CADI - Analysis DB", and "CINCO - Conferences".

Direct link: <https://twiki.cern.ch/twiki/bin/view/CMS/DrupalPhysicsCoordination>

Main channel for general communication:

[hn-cms-physics-announcements@cern.ch](mailto:hn-cms-physics-announcements@cern.ch)

➡ all “central” news, approval calls, rehearsals are announced there.

➡ Please subscribe!

All sub-groups have their own HN that you are also invited to join!



# Physics Coordination Structure



## CMS physics organization (2014)

Mandate ending Dec. 2014  
Mandate continuing or starting Sep. 2014

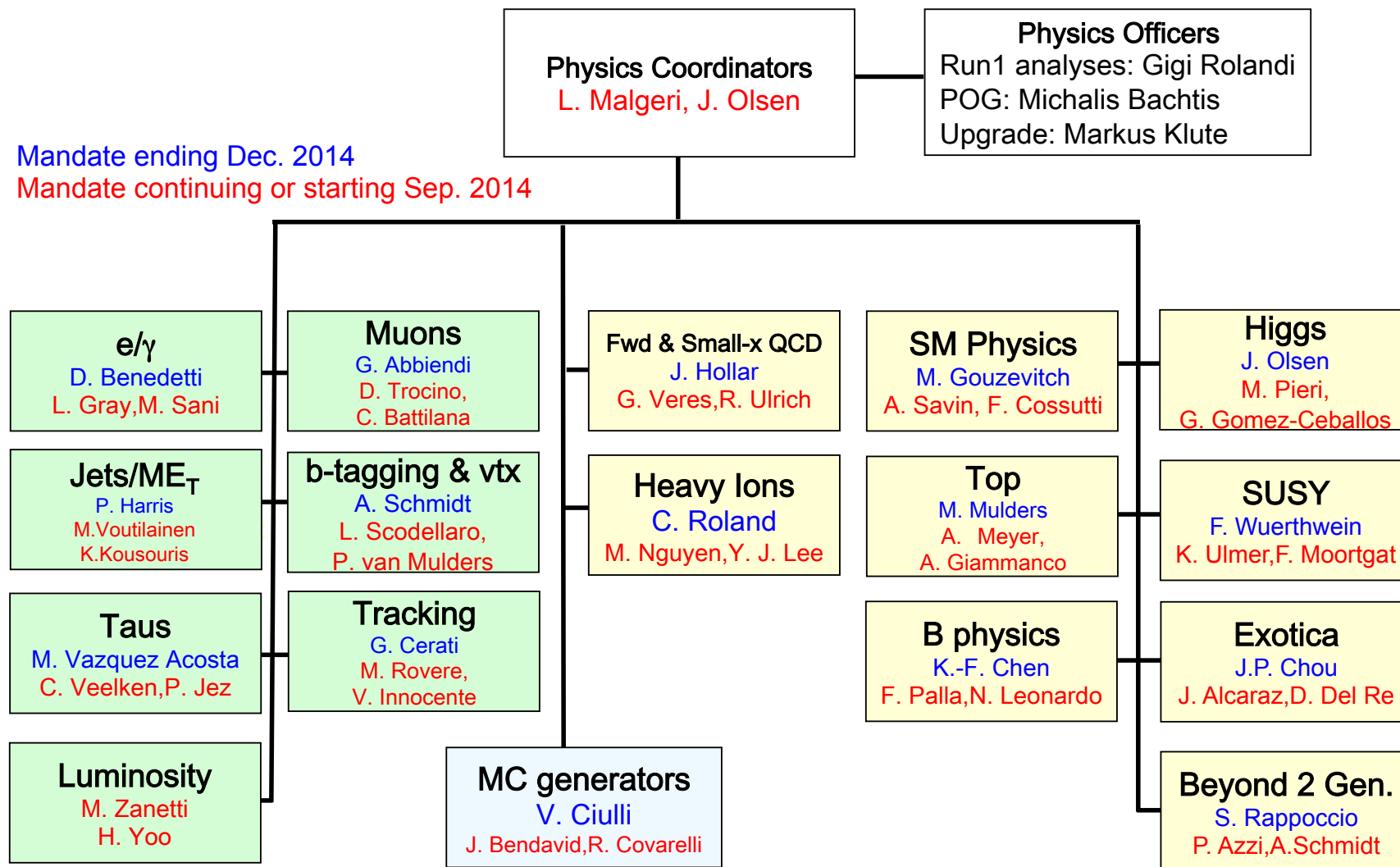



## Physics Office

Starting from Jan 2014 we have established the figures of “Physics Officers”. Three high profile colleagues helping Physics Coordination to overview three major areas:

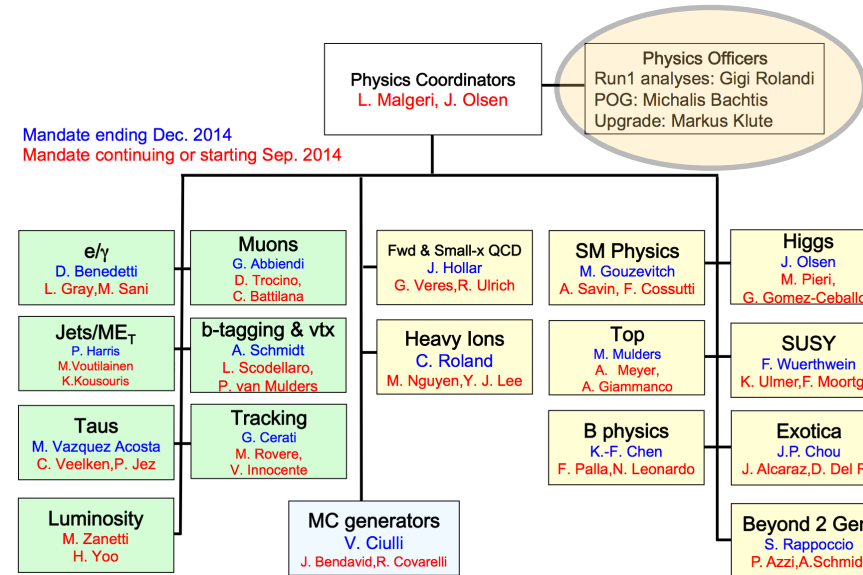

- Exploitation of the full Run I potential (aka “Legacy Papers”) Gigi Rolandi
- Upgrade Physics Studies: simulations, performance studies, preparation of TP Markus Klute
- cross-POG issues: GED(PFlow) development (run2 and beyond), improvements in physics objects; HLT Michalis Bachtis

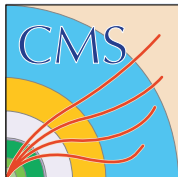

# Physics Coordination Structure



## POGs= Physics Object Groups

- Define the single “objects” reconstruction and ID.
- Work in strict contact with Trigger coordination, Offline, PPD and related Detector Performance Groups.
- Validate and certify object’s working points for physics analyses.
- Provide official recipes and recommendations on how to optimally use our objects.
- Twikis for all groups accessible from main page

**Egamma**: identification of electron and photons

**JetMET**: Jet and missing ET performance

**Taus**: the name says it all

**Muons**: the name says it all

**B-tagging & Vtx**: deals with secondary vertexing (and b-tag in general)

**Tracking**: deals with tracking and primary vertex

**Luminosity**: special POG. Delivers luminosity values for Physics analyses (several methods, tools). Work in strict contact with BRIL project.

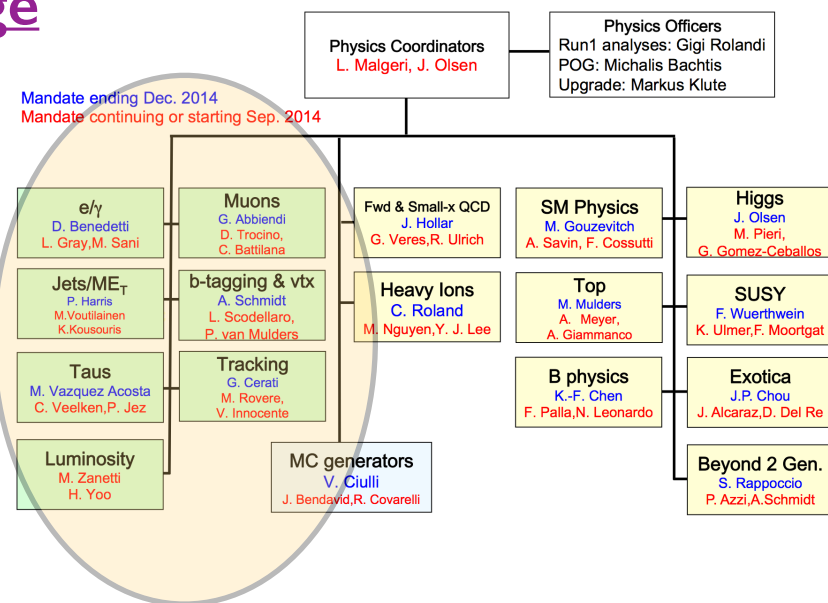



## CrossPOG forum: a new addition since Jan 2014

Forum to discuss issues common to all POGs and develop in a consistent way the future **Global Event Description** tools.

It oversees all **Particle Flow** developments (basis of our high-level reconstruction)

**Particle Flow in a nutshell:**  
 combine information from all subdetectors to define particles.  
 Deal with particles, not hits.

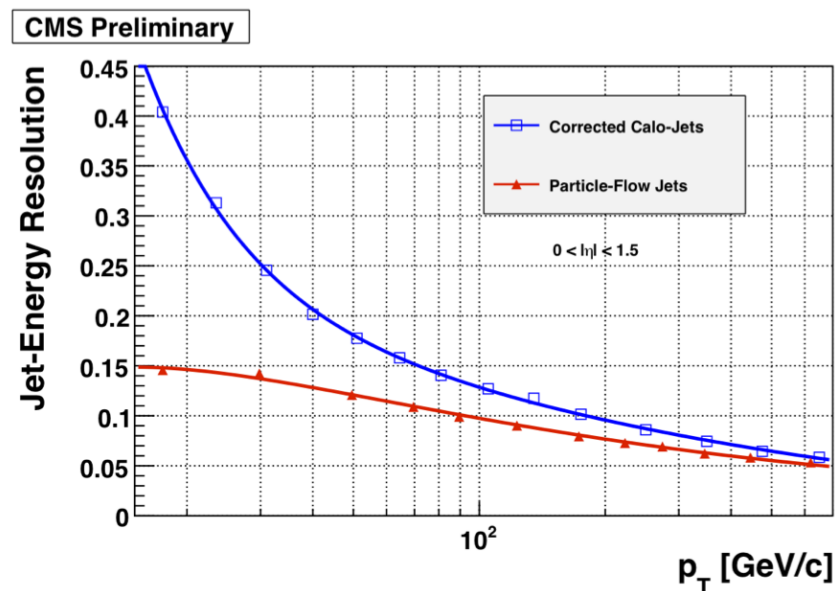
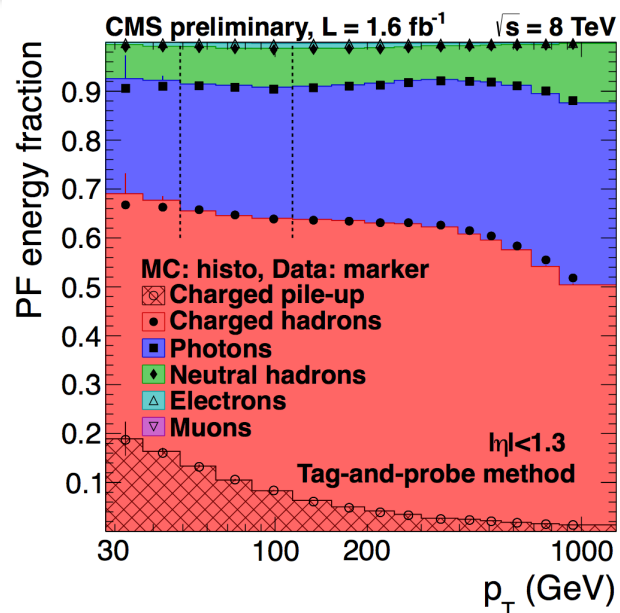
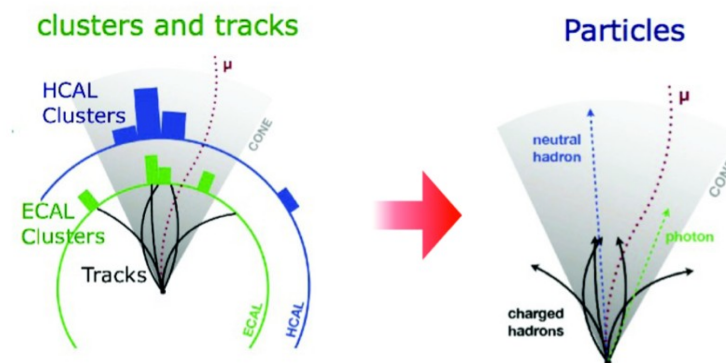

## CrossPOG forum: a new addition since Jan 2014

Current activities focussing on PU mitigation (both in time and out of time → **crucial for 25ns running!**)

Adding time information to hits to distinguish out of time contribution

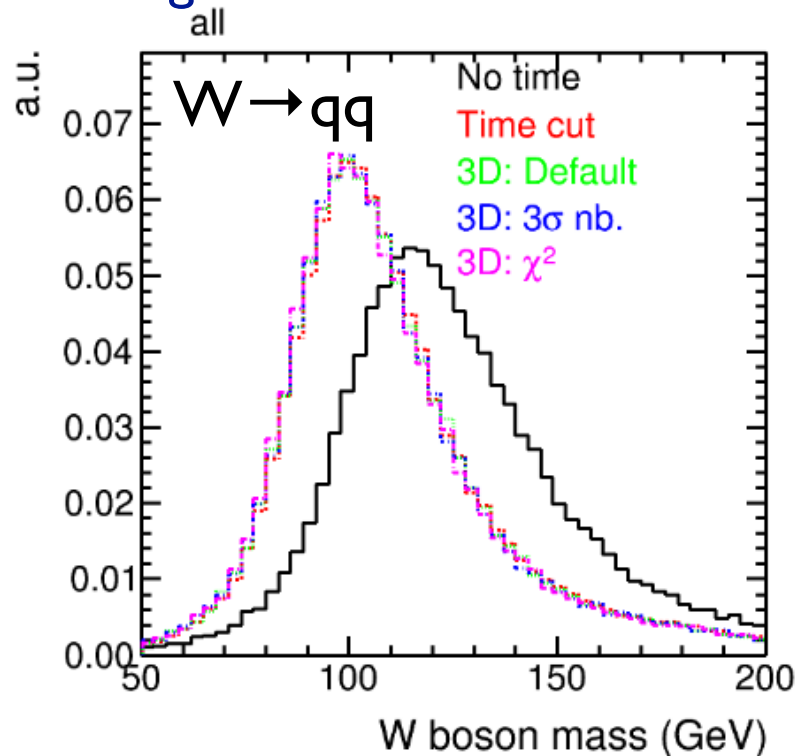

PU per Particle Identification (PUPPI) to improve in time PU mitigation

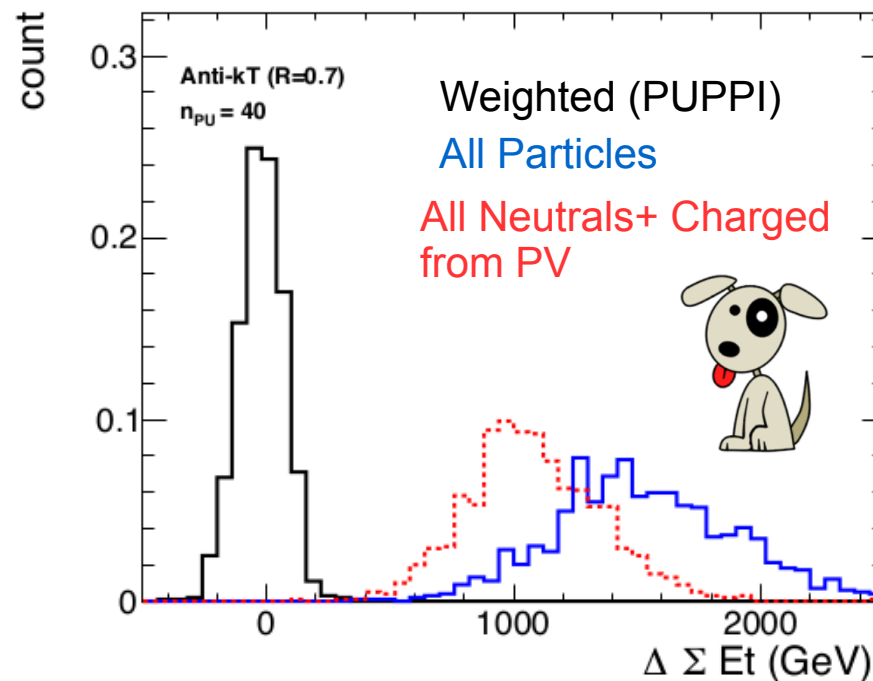

Meets (bi)-weekly on Tue: [hn-cms-eflow@cern.ch](mailto:hn-cms-eflow@cern.ch)

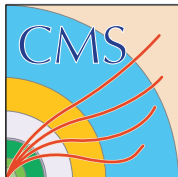

# Physics Coordination Structure



## PAGs= Physics Analysis Groups

- Oversee the physics analysis plan
- Follow single analyses associated to their group up to the approvals
- Make sure that **all recommendations are applied** and participate in forming them (through object experts)
- **Help defining Trigger strategies**
- Deal with anything going public from our analyses: conference reports, PAS, twiki pages

All twiki pages accessible from main page, including links to latest greatest results to prepare your conference report

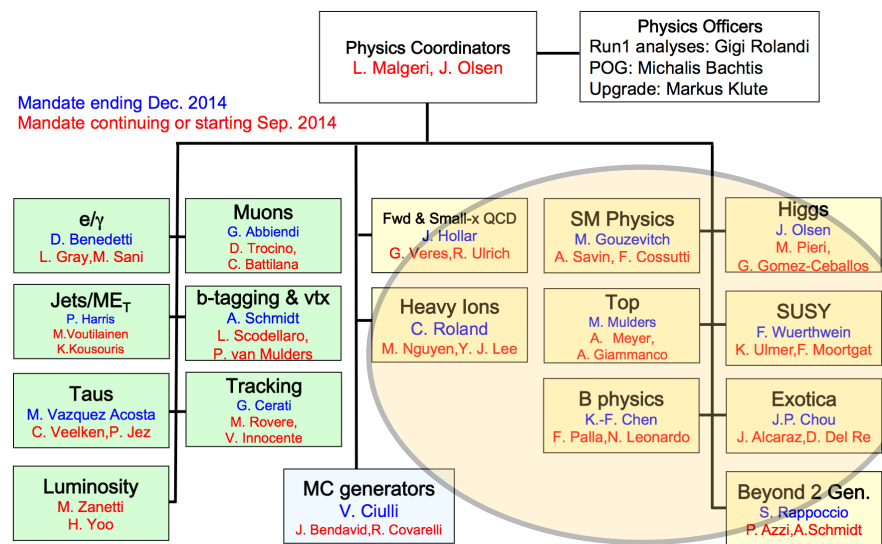

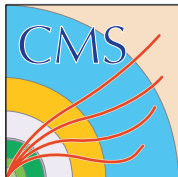

# Physics Coordination Structure



## PAGs= Physics Analysis Groups

- **FSQ**: Forward and small-x QCD analyses (interacts also with TOTEM)
- **SMP**: Standard Model Physics (apart from FSQ, TOP, Higgs and BPH)
- **HIG**: everything “Higgs” (up to a certain mass, after which it becomes EXO/SuSy)
- **HIN**: Heavy Ions analyses, including pp reference samples
- **TOP**: name says it all
- **SUS**: searches for SuperSymmetry
- **EXO**: searches for exotic phenomenologies
- **BPH**: B physics and quarkonia in general
- **B2G**: Searches based on Beyond 2nd Generation (usually top, boosted objects)
- **GEN**: in between Physics and Offline, deal with generators in general and their validation (includes UE tuning, PDF, etc.)

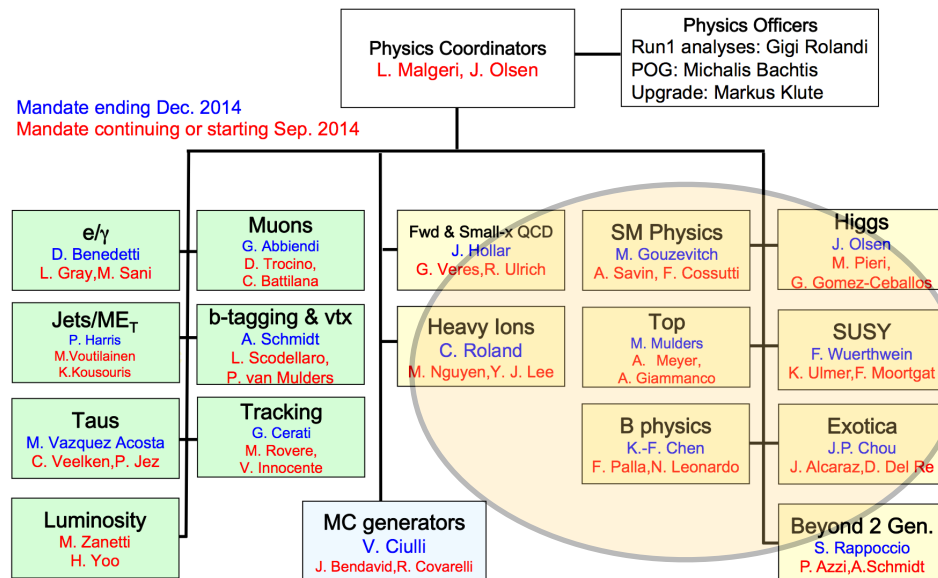



# Physics Coordination Structure



PAGs= Physics Analysis Groups

**Common results in:** <https://twiki.cern.ch/twiki/bin/view/CMSPublic/PhysicsResults>



# Physics Coordination Structure



## PAGs= Physics Analysis Groups

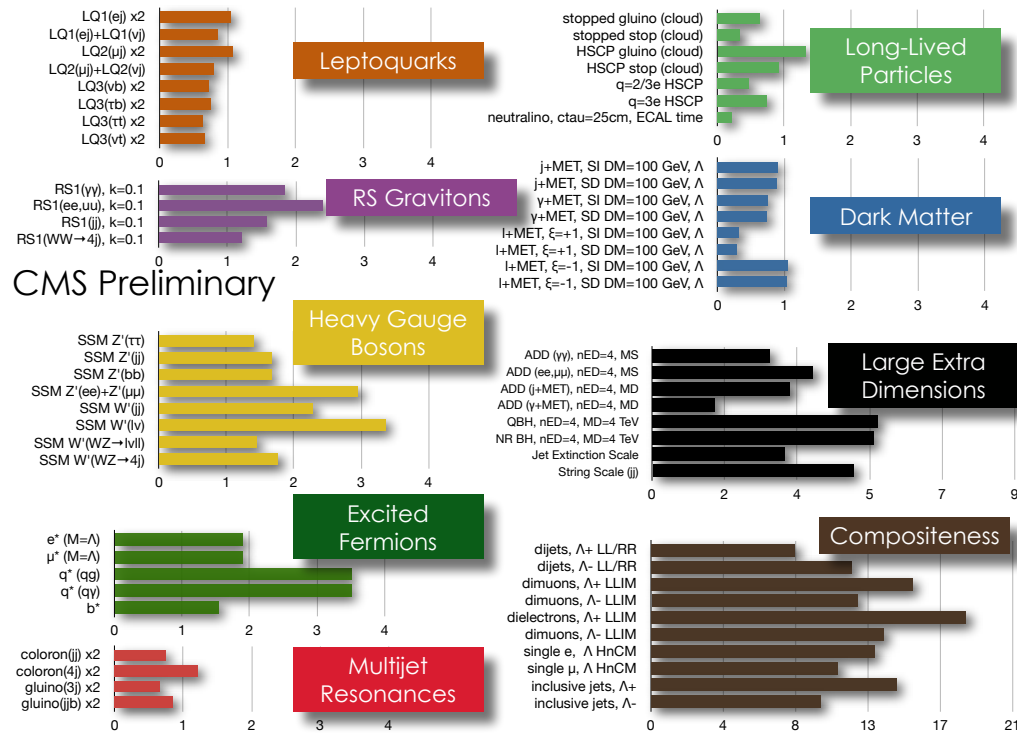

CMS Exotica Physics Group Summary – ICHP, 2014



# Physics Coordination Structure



## PAGs= Physics Analysis Groups

CMS Preliminary

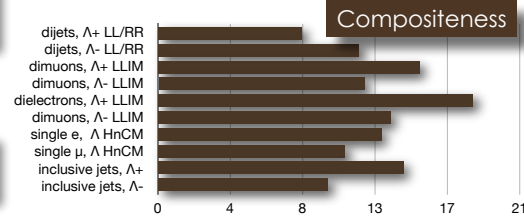
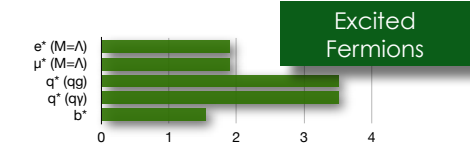
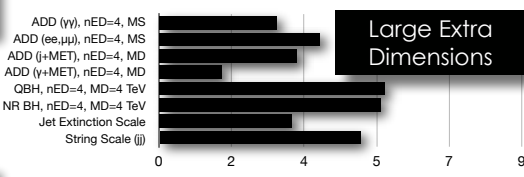
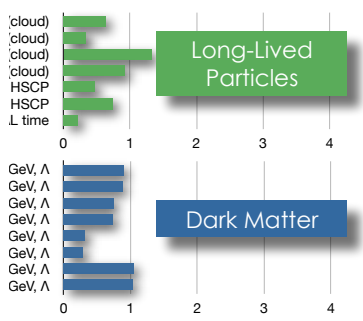
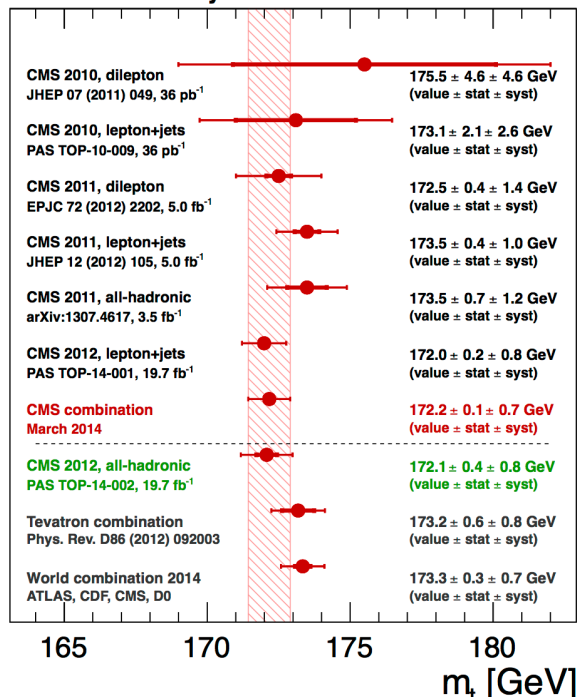



# Physics Coordination Structure



## PAGs= Physics Analysis Groups

CMS Preliminary

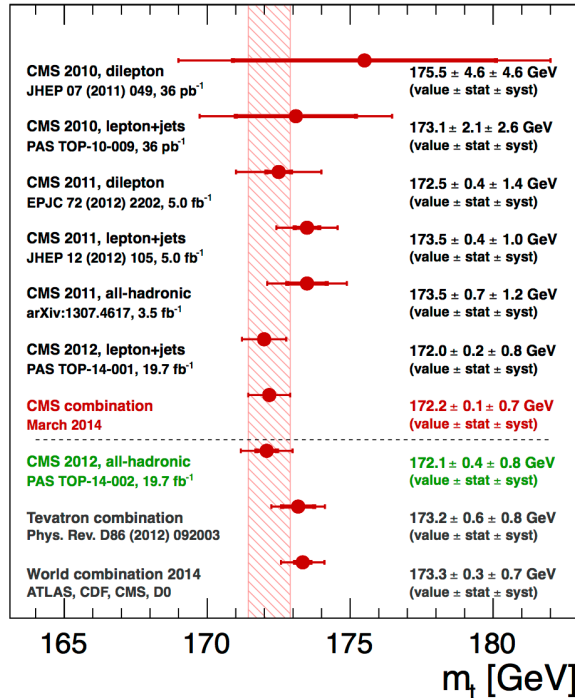

CMS Searches for New Physics Beyond Two Generations (B2G)

95% CL Exclusions (TeV)

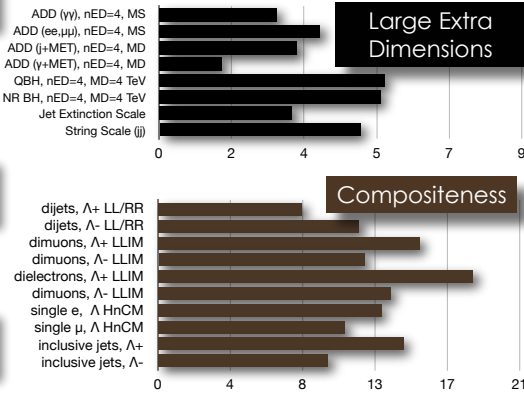
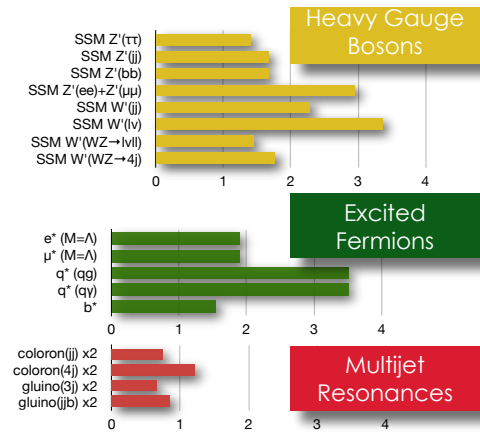
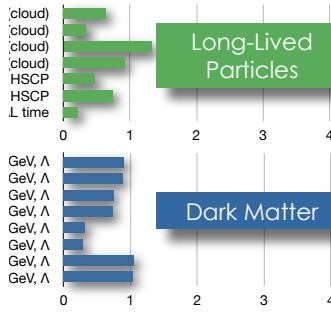
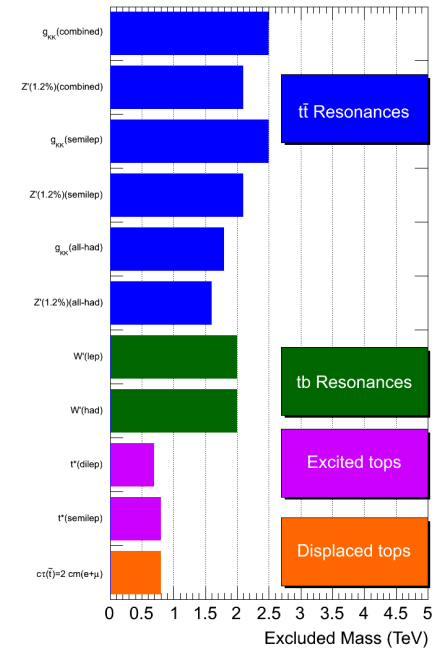
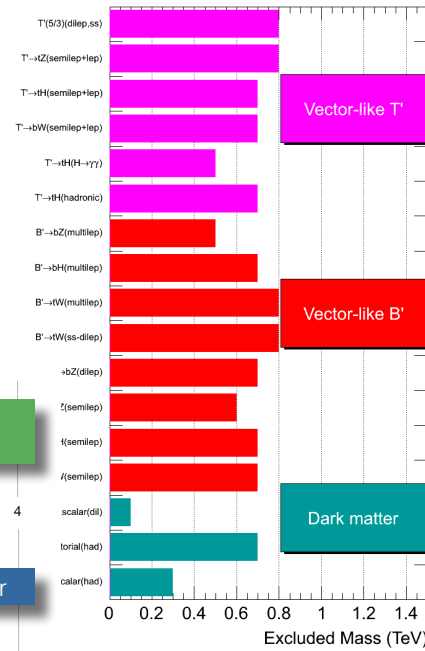







# Physics Coordination Structure



## PAGs= Physics Analysis Groups

CMS Preliminary

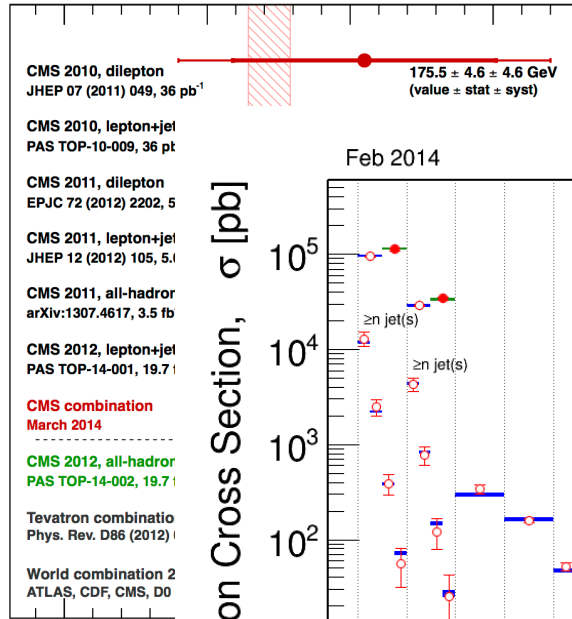

CMS Searches for New Physics Beyond Two Generations (B2G)

95% CL Exclusions (TeV)



Feb 2014

CMS Preliminary

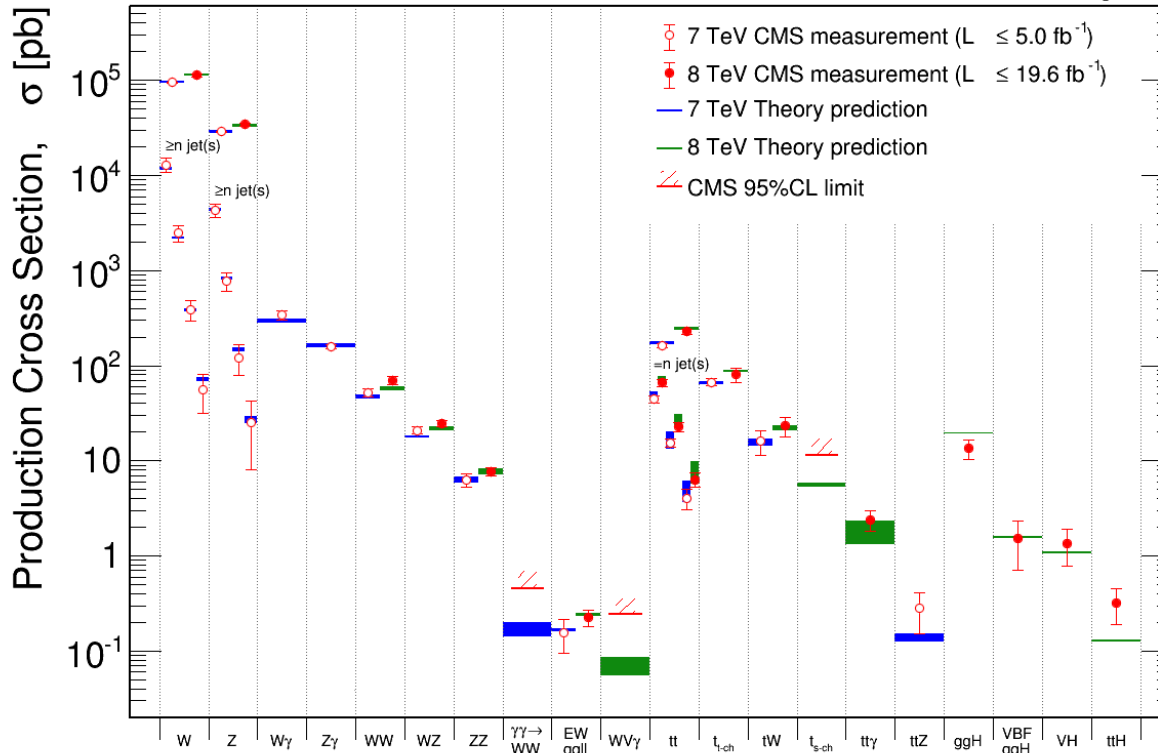

ork

ICHEP 2014

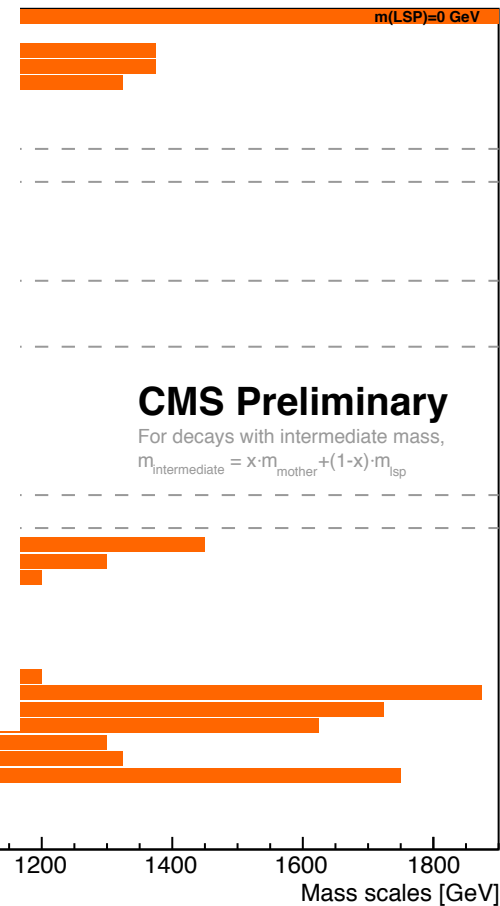

RS  
C  
165

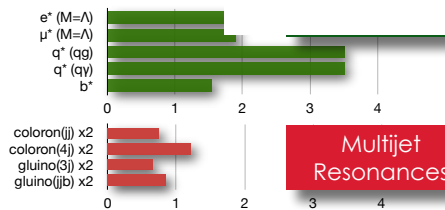
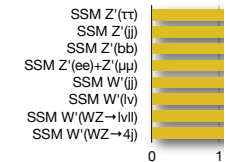

CMS Exotica Physics Group Summary - 10

\*Observed limits, theory uncertainties not included  
 Only a selection of available mass limits  
 Probe \*up to\* the quoted mass limit



## How the work is organized in POGs and PAGs

Most groups have internal working groups (a.k.a. L3 groups).

- In **POG's** they mostly address specific areas: **Identification, Reconstruction, HLT, etc.**
- In **PAG's** they mostly address specific signatures common to many analyses or needs: **leptonic, photonic, MC production, Trigger, etc.**
  - they are also the first **entry for analysis proposals and follow analyses up to pre-approval stage** (see later for more details).

Meeting structure:

- **fortnightly POG** general meetings on **Monday**
- **fortnightly PAG** general meeting on **Tuesday**
- weekly **plenary PPD and WGM** on **Wednesday**
- parallel working group meetings saturating all afternoons on **Thursday and Fridays**

Please have a look at the calendar in [https://www.dropbox.com/s/xcheni5kzee33wa/PhysRooms2014\\_pub.xlsx](https://www.dropbox.com/s/xcheni5kzee33wa/PhysRooms2014_pub.xlsx) and pay attention to the groups HN announcements/twikis.



# Physics Coordination Structure



All info seen so far (and more) can be obtained from POG and PAG twikis:

Compact Muon Solenoid experiment at CERN's LHC 

Logged in as *malgeri* Logout

Search 

**PUBLIC WEBSITE** **COLLABORATION WEBSITE**

Collaboration Coordination Tasks Detectors Upgrades **Physics** Meetings Documents Tools Help

CERN > CMS Experiment > CMS Collaboration > Tools

View Revisions

Welcome to the CMS Collaboration (Internal) Website

**Upcoming meetings**

- Fri, 11 Jul 15:00 80th USCMS Phase 1 Upgrade Technical Board
- Fri, 11 Jul 15:00 Track Trigger Integration Working Group
- Fri, 11 Jul 15:00 Trigger Meeting
- Fri, 11 Jul 15:30 STEAM meeting
- Fri, 11 Jul 15:50 SMP-VV: Multibosons (PIN

**Coordination**

- Physics Home page
- Physics Results
- LHC Physics Centre
- Procedures & Guidelines
- Analysis Tools
- Generators
- Statistics Committee
- Physics Perf. and Dataset

**Analysis Groups**

- Beyond 2 Generations
- B Physics
- Exotica
- Forward Physics
- Heavy Ions
- Higgs
- Standard Model
- SUSY
- TOP

**Physics Objects**

- B-Tagging
- Tracking
- e/gamma
- Jets/MissET
- Luminosity
- Muons
- Tau-ID

**At Work**

- Group Calendar
- Hypernews
- CADI - Analysis DB
- CINCO - Conferences

**Integrated Luminosity (fb<sup>-1</sup>)**

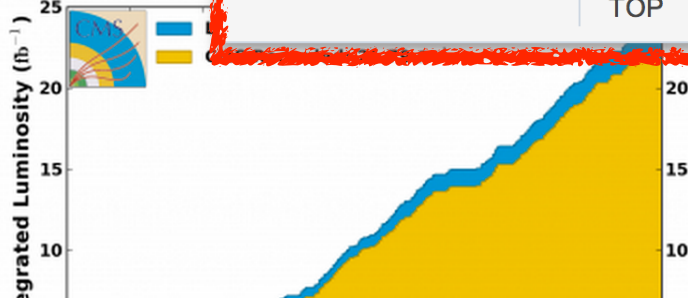



# Physics Coordination Structure



All info seen so far (and more) can be obtained from POG and PAG twikis: **TOP example**

## CMS Top Quark Physics Group

[CMS Physics](#)

**Group conveners: Andreas Meyer (DESY), Martijn Mulders (CERN)**

Previous conveners: Roberto Tenchini (Pisa), Roberto Chierici (Lyon), Frank-Peter Schilling (Karlsruhe), Tim Christiansen (CERN), Claudio Campagnari ([UCSB](#)), Jorgen D'Hondt (Brussels), Joachim Mnich (DESY)

- ↓ [Public Results](#)
- ↓ [Internal Links](#)
- ↓ [Meetings & Hypernews](#)
- ↓ [Subgroups](#)
- ↓ [Contact persons](#)
- ↓ [Useful Links](#)
- ↓ [Some historical Top PAG documents and links](#)

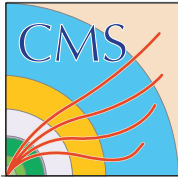

# Physics Coordination Structure



All info seen so far (and more) can be obtained from POG and PAG twikis: **TOP example**

## CMS Top Quark Physics Group

[CMS Physics](#)

**Group conveners: Andreas Meyer (DESY), Martijn Mulders (CERN)**

Previous conveners: Roberto Tenchini (Pisa), Roberto Chierici (Lyon), Frank-Peter Schilling (Karlsruhe), Tim Christiansen (CERN), Claudio Campagnari ([UCSB](#)), Jorgen D'Hondt (Brussels), Joachim Mnich (DESY)

- ↓ [Public Results](#)
- ↓ [Internal Links](#)
- ↓ [Meetings & Hypernews](#)
- ↓ [Subgroups](#)
- ↓ [Contact persons](#)
- ↓ [Useful Links](#)
- ↓ [Some historical Top PAG documents and links](#)



# Physics Coordination Structure



All info seen so far (and more) can be obtained from POG and PAG twikis: **TOP example**

## Subgroups

Group	Conveners	Twiki page	Hypernews	Meeting
Cross sections	Akram Khan, Mara Senghi Soares	<a href="#">TopCrossSections</a>	<a href="#">Cross section HN</a>	<a href="#">indico</a>
Mass	Sebastian Naumann-Emme, Pedro Silva	<a href="#">TopMass</a>	<a href="#">top-mass HN</a>	<a href="#">indico</a>
Properties	Jacob, Linacre, Efe Yazgan	<a href="#">TopProperties</a>	<a href="#">top-properties HN</a>	<a href="#">indico</a>
Single top	Rebeca Gonzalez Suarez, Orso Iorio	<a href="#">SingleTop</a>	<a href="#">Single Top HN</a>	<a href="#">indico</a>

*Twikis, meetings, HN*

**CMS To**

[CMS Physics](#)

**Group conveners**

Previous conveners

Christiansen (CERN)

↓ [Public Relations](#)

↓ [Internal Liaison](#)

↓ [Meetings](#)

↓ [Subgroups](#)

↓ [Contact persons](#)

↓ [Useful Links](#)

↓ [Some history](#)

## Contact persons

Task / Liaison	contact persons	additional info/links
Software and Documentation	Volker Adler	<a href="#">TWikiTopRefEventSel</a> , <a href="#">SWGGuideTQAF</a>
Datasets / T2 space managers	Annik Olbrechts, Lukasz Kreczko, Thorsten Chwalek	<a href="#">TopSamplesT2Locations</a>
Trigger, TSG, SDs, Skims	Javier Fernandez, Stephanie Beuceron	<a href="#">TOP Trigger Analysis</a> - <a href="#">TopTriggerPlanning</a> - <a href="#">indico</a> - <a href="#">Top Trigger HN</a>
GEN group, MC production	Jan Kieseler, Markus Seidel, Benedikt Maier, Javier Fernandez, James Keaveney	<a href="#">TopMonteCarlo</a>
DQM, PVT	Abideh Jafari, Enrique Palencia	<a href="#">TOP DQM main Twiki</a>
JME	Henning Kirschenmann, Nathan Mirman	<a href="#">TOP JetMET Analysis</a>
EGM	Kelly Beernaert, Nik Berry	<a href="#">TOP EGM Analysis</a>
MUO	Carlo Battilana, Carmen Diez Pardos	<a href="#">TOP MUO Analysis</a> - <a href="#">TOP-MUO Coordination</a>
TAU	Federico Nguyen	<a href="#">TOP TAU Analysis</a>
BTV	James Keaveney, Luca Scodellaro (interim)	<a href="#">TOP BTV Analysis</a>
Fast Sim	Andrea Giammanco	
Conference Support	Andrea Giammanco, Efe Yazgan	

(Karlsruhe), Tim (DESY)

*Additional info*



# CMS product: publications





# What kind of documents we produce



We have 5 types of public documents:

- 1) **Journal Publications**: they appear on refereed journals and are signed by the whole CMS Collaboration
- 2) **Physics Analysis Summaries (PAS)**: summary documents usually in preparation for a paper or a conference contribution. Many PAS can be “concentrated” in a single paper.
- 3) **Detector Performance Summaries (DPS)**: equivalent of PAS for performance plots and detector related analyses. They are managed jointly by Physics Coordination, Run Coordination and PPD.
- 4) **Conference Reports (CR)**: proceedings to be submitted to conference.
- 5) **CMS Notes**: it is now obsolete (absorbed by PAS), so please forget about it.

Please note:

- All documents, apart CR, are signed by the whole CMS Collaboration
- All public documents must pass an internal review.

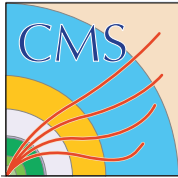

# What kind of documents we produce



We have 3 types of private documents:

- 1) **Analysis notes (AN)**: they are usually in support of a PAS with detailed documentation on analysis single step. They are used in the internal review of analyses and should be kept up-to-date.
- 2) **Detector Performance Notes (DP)**: it is the private version of a DPS. Usually contains more material and explanation w.r.t. a DPS to help CMS speakers in conferences.
- 3) **Internal Notes (IN)**: they were used as internal backup material of CMS Notes. They are now much less, if at all, used.
- 4) **Detector Notes (DN)**: focussed on technical aspects of the detectors and managed usually internally in every single project.

Please note:

- All private documents have explicit reference to the authors
- No real wide review, but only a check that the material is not inappropriate.



# The story of a physics analysis in CMS



## Step 1:

- You have an idea
- You don't have an idea but you'd like to contribute
  - ➔ individuate a group and talk directly to group/sub-group conveners

## Step 2:

- participate in the activity of the subgroup on everything needed to complete it:
  - do you need a particular sample?
    - ➔ Help becoming a MC production expert
  - do you need a particular object?
    - ➔ Work in the POG in order to get it as performant as you need it (and for the whole CMS)
  - do you need a particular workflow?
    - ➔ Develop it and propose it to PPD.
  - do you need a special trigger?
    - ➔ Work in LI and HLT in order to set it up (in a way that is useful to the whole CMS)
  - This list can continue forever but probably you've got the point.

## Step 3:

- Start presenting your analysis (or your group analysis) in the pertinent working group until you reach a state that is judged sufficient for pre-approval

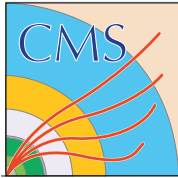

# The story of a physics analysis in CMS



## Step 4:

### • Pre-approval

- it is usually held inside a working group meeting and called by the sub-group conveners. This is also the time when an ARC (Analysis Review Committee) is appointed and start to follow your analysis.

## Step 5:

### • Approval

- it is usually held inside a general group meeting and called by the POG/PAG convener. The ARC should give a green light for the approval.
- after approval the analysis is ready to be shown in public as preliminary result unless it was agreed to go directly to a paper (it is usually the case when there is already a first preliminary result).

## Step 6:

### • Collaboration Wide Review

- everybody in the collaboration is asked to comment on the paper
- this step is coordinated by the Publication Committee

## Step 7:

### • Final Reading and submission to a journal

- the Publication Committee evaluates the comments from CWR and schedule a FR to wrap it up



# The story of a physics analysis in CMS



A more formal timeline from main PC twiki page:

Procedure and Guidelines: <https://twiki.cern.ch/twiki/bin/viewauth/CMS/Drupal-CMSRules>

Stage/event	Responsibility	Actions	Comments
Early stages of an analysis	<b>PAG conveners</b>	Analysis record is created on CADI web page (i).	
	<b>Authors + WG conveners</b>	Analysis is discussed regularly in the working group	
	<b>Authors + POG conveners</b>	If analysis uses non-standard tools, these must be reviewed & approved by the relevant POG	The procedure to be followed for formal pre-approval in a POG is identical to that for formal pre-approval in a PAG
Prior to scheduling pre-approval	<b>PAG conveners</b>	Target dates for pre-approval updated in CADI	
	<b>PAG conveners</b>	Request formation of ARC	Preferably at least 2 weeks before pre-approval meeting
	<b>WG conveners</b>	Read preliminary version of PAS & supporting AN-NOTE approximately 1 week prior to preapproval announcement. Thus decide if pre-approval can go ahead.	
Announcement of pre-approval meeting	<b>Authors</b>	PAS (iv) & supporting AN-NOTE(s) submitted & frozen in CADI until pre-approval	Authors can continue to edit latex in response to comments, but not submit new drafts to CADI.
	<b>PAG conveners</b>	Announce pre-approval meeting on Hypernews(ii)	May happen only hours after PAS put into CADI.
<b>AT LEAST ONE WEEK</b>			<b>Conveners, ARC</b> and general members of CMS to read documents .
<b>Pre-Approval meeting</b>	<b>WG/PAG Conveners</b>	Decide if analysis is (conditionally) pre-approved.	ARC should ideally attend (as observers).
After pre-approval meeting	<b>Authors</b>	Post new version of PAS (iv) & AN-NOTE(s) to CADI, taking into account comments made during pre-approval. Document all questions/answers on twiki.	
	<b>PAG conveners</b>	If analysis was pre-approved (or conditionally pre-approved & conditions have been met by revised documentation), set flag in CADI and announce on Hypernews (ii)	CADI status flag ♦ Pre-App
	<b>Authors</b>	Discuss analysis schedule with ARC chairperson	Helps minimize time between pre-approval and approval
<b>N WEEKS</b>			<b>ARC Review</b> of analysis (Usually takes at least 2 weeks). If major changes to the analysis are needed, the ARC may recommend that it be sent back to PAG for re-preapproval.
Prior to scheduling approval	<b>Authors</b>	Post new version of PAS (iv) & AN-NOTE(s) to CADI, taking into account comments made by ARC. Document all questions/answers on twiki.	
	<b>ARC</b>	Decide whether analysis is ready for approval meeting, announce this on Hypernews (iii) & set flag in CADI.	CADI status flag ♦ ARC-GreenLight





# The story of a physics analysis in CMS



A more formal timeline from main PC twiki page:

Procedure and Guidelines: <https://twiki.cern.ch/twiki/bin/viewauth/CMS/Drupal-CMSRules>





Stage/event	Responsibility	Actions	Comments
Announcement of Approval meeting	Authors	All documentation is frozen in CADI until the approval meeting. Any plots to be made public (especially those not in PAS) should be posted to twiki.	Authors can continue to edit latex in response to comments, but not submit new drafts to CADI.
	Phys. Coord.	Announces approval meeting is on Hypernews (ii)	
	Language Editor	In exceptional circumstances only, Language Editor improves English in PAS or draft PAPER (iv). This only happens if the PAS is very badly written or if the PAS/PAPER is very important. (e.g. Discovery).	Can work on latex whilst PAS (iv) is frozen, uploading new draft to CADI only after approval meeting.
 <b>AT LEAST ONE WEEK</b> 			Members of CMS read the documentation.
Approval meeting	ARC	Makes statements about the analysis	Changes made to the analysis, after documentation was frozen, must be highlighted. Major changes require a return to pre-approval.
	PAG conveners/P.C.	Decide if the analysis is (conditionally) approved & announce it on Hypernews(ii)	
After approval meeting	Authors	Post new version of PAS (iv) & AN-NOTE(s) to CADI, taking into account comments made during approval. Document all questions/answers on twiki.	
	ARC	Check that authors have implemented all comments and announce this in Hypernews (iii)	
	PAG conveners	If analysis was approved (or conditionally approved & conditions have been met by revised documentation), set flag in CADI.	CADI status flag ♦ Phys-App
	ARC	Check quality of plots on twiki that authors wish to publish. If good enough for publication, set CADI flag.	CADI status flag ♦ PAS-readyForPub
	PAG conveners	Make plots on twiki public (v).	
	Physics Coord.	Make PAS public (v).	CADI status flag ♦ PAS-readyForPub Phys. Coord. may decide not to make the PAS itself public if the intention is to publish almost immediately in a journal.



# The story of a physics analysis in CMS



## Additional steps for a publication in a journal

Starting Point	Analysis assumed to have already been formally "approved" & documented in PAS + AN-NOTE(s)			
	<b>Authors</b>	Write PAPER, if not already done.	This may be very similar to the PAS.	
	<b>ARC</b>	Once decent draft paper exists, ask Pub. Comm. Board chair to assign a Language Editor to the PAPER.	CADI status flag ♦ Pub-Draft	
	<b>Language Editor</b>	Improve English in paper.		
<b>Prior to Collaboration Wide Review</b>	<b>ARC</b>	Check that comments made during approval meeting have been implemented & language editor has finished. Then indicate that it is ready for CWR in hypernews (i) and by changing CADI flag.	CADI status flag ♦ ReadyForCWR	
	<b>Pub. Comm. Chair</b>	Copy PAPER from CADI (ii) to CDS web page (iii).	CADI status flag ♦ CWR	
<b>Announcement of Collaboration Wide Review</b>	<b>Pub. Comm. Chair</b>	Assign ~4 institutes to review it.		
	<b>Pub. Comm. Chair</b>	Ask Stat. Comm. to review it.		
	<b>Pub. Comm. Chair</b>	Announce start of CWR (iv).		
		<b>2 WEEKS</b>		
<b>After Collaboration Wide Review</b>	<b>Authors</b>	Post new version of PAPER to CADI, taking into account comments made during pre-approval. Document all questions/answers on twiki.		
	<b>Language Editor</b>	Improve English in paper.	Arbitrate on English comments made during CWR & check that authors do not introduce any new English errors.	
	<b>ARC</b>	Check that comments made during CWR have been implemented & language editor has finished. Then indicate that it is ready for FR in hypernews (i) and by changing CADI flag.	CADI status flag ♦ ReadyForFR	
<b>Before Final Reading</b>	<b>Pub. Comm. Chair</b>	Arrange Final Reading		
		<b>A FEW DAYS AT LEAST</b>		
<b>Final Reading</b>	<b>Pub. Comm.</b>	Discuss paper, in particular any unresolved comments from Pub. Comm. Members.	<b>ARC Chair &amp; Analysis Contact Person</b> (author) to attend. Both to note any action items from the meeting.	
<b>After Final Reading</b>	<b>Authors</b>	Post new version of PAPER to CADI, taking into account comments made during the FR.	Should only take a few days ...	
	<b>Language Editor</b>	Improve English in paper.	Check that no new English errors added in these final steps.	
	<b>ARC</b>	Check that all comments have been implemented & Language Editor has finished. Then announce in Hypernews (i).		
	<b>Pub. Comm Chair</b>	Submit to journal.		

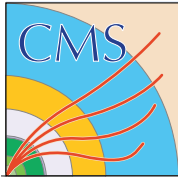

## Few important things to keep in mind.

- Despite the minimal required time between the steps, in general you should foresee (by experience):
  - at least 1 month between pre-approval and a public Physics Analysis Summary
  - at least 2 months between analysis enter CWR and submission to a journal
- The documentation freezing time is not there to punish the analyzers, but to allow the full collaboration to get involved and give comments
- We have two basic ways to exchange information on an analysis:
  - the dedicated HN forum (created automatically using the CADI interface, see later)
  - the dedicated twiki pages (private and public versions) that will stay forever also as additional material, if agreed upon.



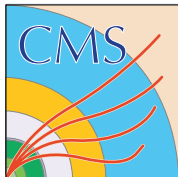

# What next after approval? Publication

Slides from Gautier Hamel de Monchenault

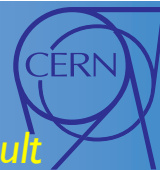

## Role of Publication Committee

<https://twiki.cern.ch/twiki/bin/viewauth/CMS/CMSPubComm>

- The CMS Publications Committee (PubComm) is responsible for the high editorial quality of all CMS publications and public documents
- The PubComm defines the **CMS standards** for detector descriptions, figures, formats, styles, symbols, etc.
- The PubComm is organized in **seven Editorial Boards (EB)**
- The EB chairs form the PubComm Steering Board

## CMS Publications Committee

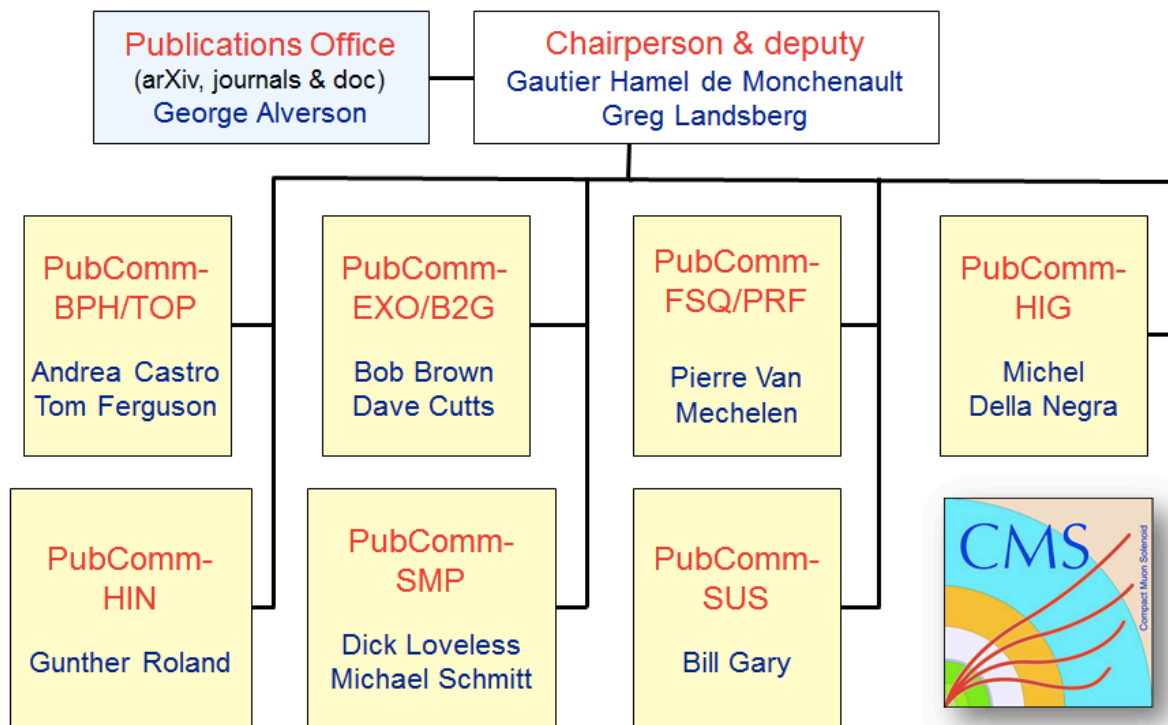



# What next after approval? Publication

Slides from Gautier Hamel de Monchenault

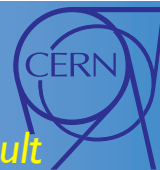

## Milestones of a physics publication in CMS

<https://twiki.cern.ch/twiki/bin/view/CMS/ArcCollaborationWideReview>

- The PubComm chair and the Physics Coordinator appoint the Analysis Review Committee (ARC: 4 members)
- The work of the Editorial Board starts when the analysis is approved
- A language editor (LE) is appointed
- The draft paper is circulated in the Collaboration (CWR)
- All comments are included for the Final Reading (FR)
- The paper is submitted to the journal
- The paper is published

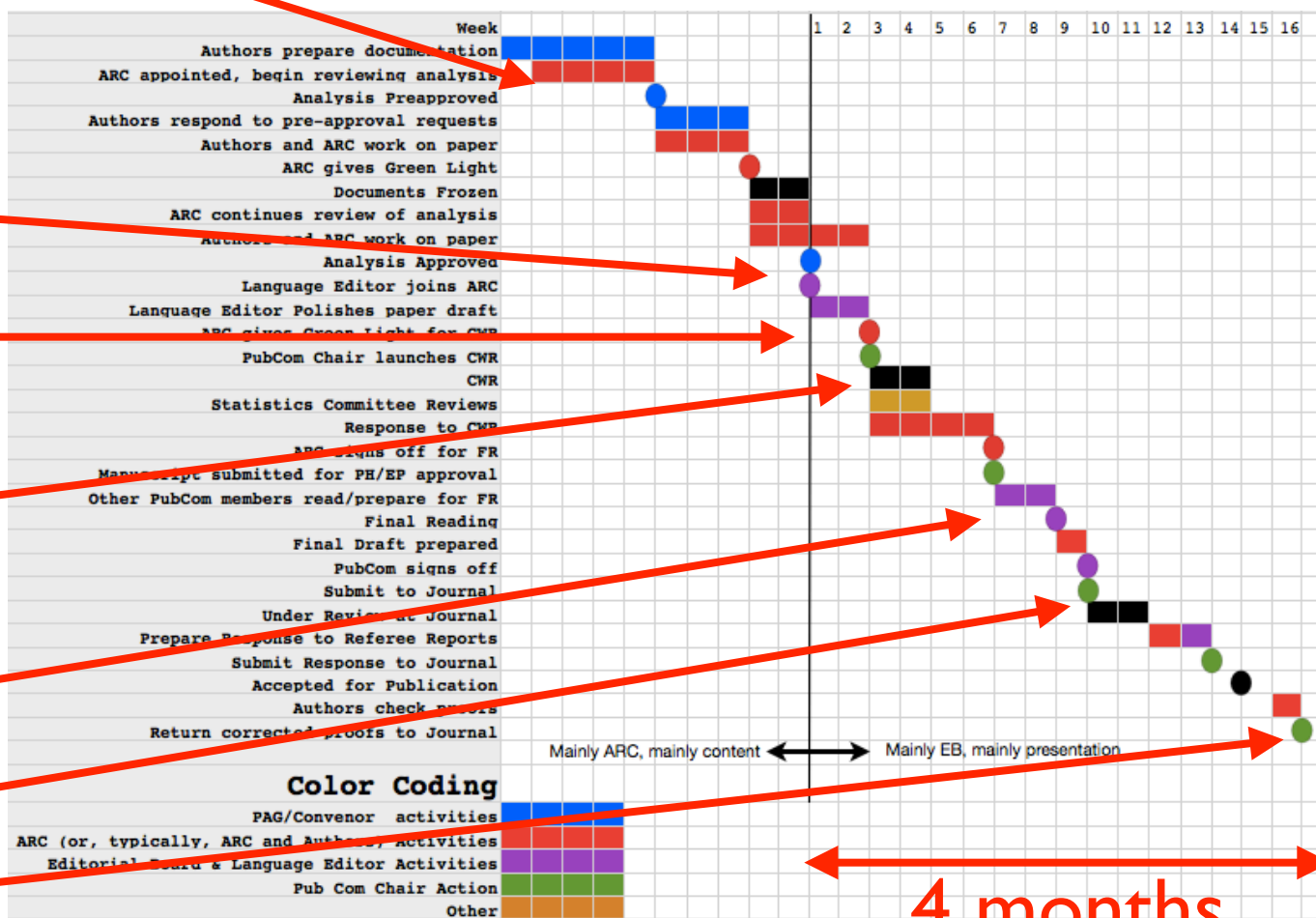

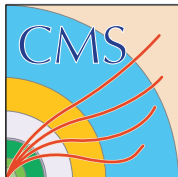

# What next after approval? Publication

Slides from Gautier Hamel de Monchenault



## CMS publications so far

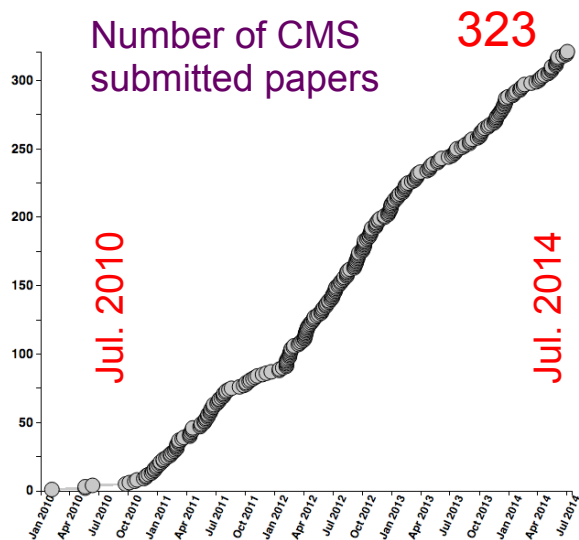

All CMS papers are published Open Access in:

**JHEP, PLB, EPJC, JINST, PRL, PRD, PRC,**  
**Nature Physics and Science**  
 (red=SCOAP3, blue=APS, green=other)

### Submitted by CMS:

- 323 papers (collision data)
- 1 paper (cosmic ray data)
- 10 detector papers
- 1 tau performance paper
- 1 paper in Science
- 23 CRAFT papers

	JHEP	PLB	PRL	EPJC	PRD	PRC	NatPh	SUB	PUB
EWK	6	5	2	1	3	0	0	17	17
QCD	11	3	5	3	3	0	0	25	25
FWD	5	1	0	2	1	0	0	9	9
SMP	8	5	3	5	3	0	0	24	13
FSQ	3	0	0	3	1	0	0	7	5
BPH	9	6	6	2	2	0	0	25	24
TOP	12	7	6	8	3	0	0	35	30
HIG	10	10	4	4	2	0	1	31	27
SUS	15	7	7	5	8	0	0	42	37
EXO	21	28	15	1	8	0	0	73	67
B2G	3	2	2	0	0	0	0	7	7
HIN	6	7	7	4	0	3	0	28	25
<b>TOTAL</b>	<b>108</b>	<b>81</b>	<b>57</b>	<b>38</b>	<b>34</b>	<b>3</b>	<b>1</b>	<b>323</b>	<b>286</b>

Grand total = 359 CMS papers submitted



# Where to find information on analyses



We have a single database that stores all info.  
**CADI** (CMS Analysis Database Interface).

Important note:

use this new link: <http://cms.cern.ch/iCMS/analysisadmin/cadilines>  
and **NOT** the old link: <http://cms.cern.ch/iCMS/jsp/analysis/admin/analysismanagement.jsp>

unless you want to wait for ages before getting a page  
(unfortunately the new link is not yet propagated everywhere)

<a href="#">AWGs</a>   <a href="#">Notes</a>   <a href="#">ARCs</a>   <a href="#">IRCs</a>   <a href="#">Misc</a>		<a href="#">show Analysis papers</a>   <a href="#">Admin ToDo list</a>   <a href="#">Analysis Management &gt;&gt;</a>			
<a href="#">switch to EDIT mode</a>   <a href="#">set FULL Info</a>		<a href="#">show Analyses</a> <input type="text" value="any"/> in <input type="text" value="any"/> with Status <input type="checkbox"/> after <input type="text" value="any"/>			
Code	Name	Status	PAS	PAPER	ARC
<a href="#">B2G-12-001</a> »   <a href="#">show</a>	Search for t' pair production in the dilepton channel	Free			NO ARC
<a href="#">B2G-12-002</a> »   <a href="#">show</a>	Search for baryon-number violating top decays into 2 jets and 1 lepton	PAS-PUB			Jorgen D'Hondt (BRUSSEL-VUB)
<a href="#">B2G-12-003</a> »   <a href="#">show</a>	Search for a heavy partner of the top quark with charge 5/3	PAS-PUB			Sridhara Rao Dasu (WISCONSIN)
<a href="#">B2G-12-004</a> »   <a href="#">show</a>   <a href="#">CDS</a>   <a href="#">JHEP</a>	Search for b' pair production in the lepton + jets channel	PUB			Andrea Giammanco (LOUVAIN)
<a href="#">B2G-12-005</a> »   <a href="#">show</a>	Search for ttbar resonances in boosted all-hadronic final state	PAS-only-PUB			Vyacheslav Krutelyov (UCSB)
<a href="#">B2G-12-006</a> »   <a href="#">show</a>	Search for ttbar resonances in semileptonic final state	PAS-only-PUB			Kevin Patrick Lannon (NOTRE_DAME)
<a href="#">B2G-12-007</a> »   <a href="#">show</a>	Search for ttbar resonances in dileptonic final state	PRE-APP			Kevin Patrick Lannon (NOTRE_DAME)



# Where to find information on analyses



We have a single database that stores all info.

**CADI** (CMS Analysis Database Interface).

## What you can do with CADI (just a short list):

- define a new analysis (for the conveners)
- change its status (defined, pre-approval, approved, published, etc.)
- ask for dedicated HN
- define tentative targets (dates, conference)
- link documents
- define ARCs (for PC and Pub.Comm)
- dig out history of analyses and ARCs
- upload additional material (still under work)
- contact authors and other interested people in a single analyses
- .....

**In short: it is your single stop to get info on what is going on**

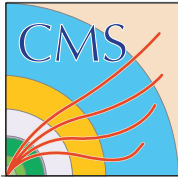

# First steps in a physics analysis



# Few practical hooks for the “first steps”



You know now:

- how we took our data
- how they are separated in datasets (trigger paths, skims, etc.)
- where to look for them (DAS and alike)
- what are the steps in order to get an analysis approved and shown at conferences

In the next few slides you will have some practical hooks on how to produce your first plots

- how to get a quick look at the data (with examples)
- how to access data on the grid
- how to deal with complex statistical procedure

**CAVEAT:** this is far from being a tutorial!

For real tutorial please have a look (for example) at CMS Data Analysis Schools:

<https://espace.cern.ch/learncms/AnalysisSchoolCERNJan14/SitePages/Home.aspx>

The screenshot shows the website for the CMS Data Analysis School CERN Jan 2014. The page has a dark blue header with 'Site Actions', 'Browse', 'Page', 'Publish', and 'Sign In'. Below the header is the CERN logo and the page title 'CMS Data Analysis School CERN Jan 2014 > Home'. A search bar is located on the right. The main content area features a list of links to other schools and a 'Welcome to CMSDAS, Jan 13-18 2014 at CERN' message. There are also links to the agenda, twiki, and exercises.



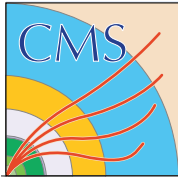

# Few practical hooks for the “first steps”

Slides from Tae Jeong Kim

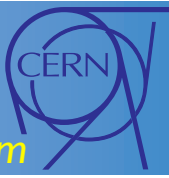

For your first interaction with CMSSW and data analysis, **PAT** (Physics Analysis Toolkit) should be the way to go.

**PAT** is a toolkit, part of the CMSSW framework, aimed at performing analysis.

<https://twiki.cern.ch/twiki/bin/view/CMSPublic/SWGuidePhysicsTools>

## Interface

Between RECO expertise and analysis contacts

Simplifies access via dataformats

Canalizes expertise of Physics Object Group (POG) and Physics Analysis Group (PAG)

## Common Tool

approved algorithms & sensible defaults

synergy (everybody can profit from recent developments)

quick start into analysis for the beginners

## Common Format

facilitates transfer & comparisons

PAG common configurations

sustained provenance



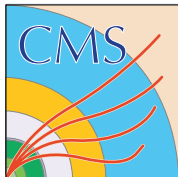

# Few practical hooks for the “first steps”

Slides from Tae Jeong Kim



## How to organize your analysis?

- Producing and using PAT objects
  - All up-to-date features collected from all POGs
  - Get latest algorithms always from the same interface: the PAT objects
- Can use centralized PAT production → miniAOD (this is new!!)

### MINIAOD: OVERALL IDEA

- Typical Run 1 analysis workflow

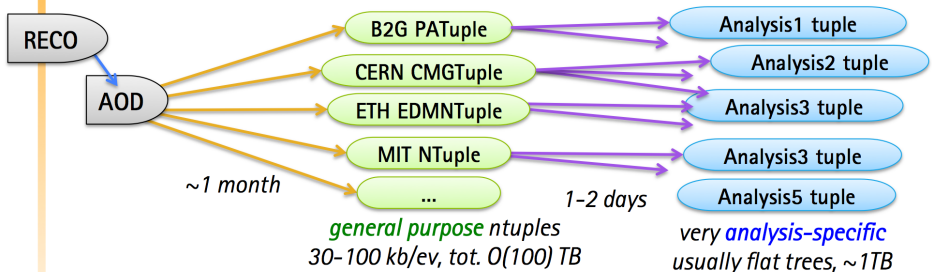

- With a MiniAOD

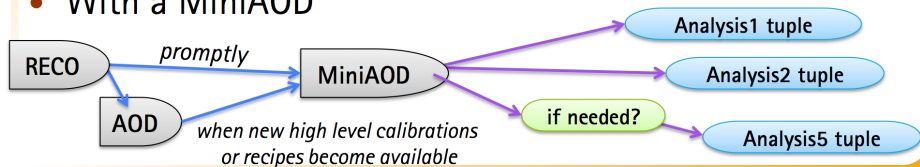

28.05.14

A. Rizzi (Pisa), G. Petrucciani (CERN)

3

Dataset	PU	kb/evt
SingleMu-Run2012D-15Apr2014	2012D	18
DoubleElectron-Run2012D-15Apr2014	2012D	26
DYJetsToLL_M-50_13TeV-madgraph-pythia8	20 (25ns)	29
DYJetsToLL_M-50_13TeV-madgraph-pythia8	20-50 (50ns)	40
TT_Tune4C_13TeV-pythia8-tauola	20 (25ns)	40
TT_Tune4C_13TeV-pythia8-tauola	S14* (50ns)	46
VBF_HToZZTo4L_M-125_13TeV-powheg-pythia6	S14* (50ns)	40
TTbarH_HToWWTo2LAndTauNu_M-125_13TeV_pythia6	20 (25ns)	46
RSgluonToTT_M-4000_Tune4C_13TeV-pythia8	20 (25ns)	44
RSgluonToTT_M-4000_Tune4C_13TeV-pythia8	S14* (50ns)	49

(\*) CSA14 50ns scenario: 50% flat 20-50 PU plus 50% fixed 40 PU

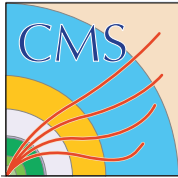

# Few practical hooks for the “first steps”

Slides from David Lange



To simplify the analysis tasks (and also to make them uniform) we are moving towards using **Analysis certified CMSSW Releases**.

## Concept:

Releases created specifically for analysis code integration such as:

- **PAT** developments (e.g., **miniAOD**)
- POG object ID recipes (goal to stay up to date with Twiki page recipes)
- Broadly use ntuple making codes
- Other developments that naturally lag behind release cycle that focuses on simulation and reconstruction timelines.

## Planned implementation:

- Analysis releases would start once CMSSW release has stabilized and is in use for reconstruction
- Clear deadlines: approximately monthly, adjusted to match “object reviews” or other deadlines as needed

Implementation starting with the release cycle for **CSA I4 (Computing, Software and Analysis challenge starting now)** – watch the release announcements forum for more news:

[hn-cms-relAnnounce@cern.ch](mailto:hn-cms-relAnnounce@cern.ch)



# Few practical hooks for the “first steps”



How do you access full datasets on the GRID?

**CRAB !**

CRAB (CMS Remote Analysis Builder) is software & hardware infrastructure used by CMS to submit analysis jobs to the LHC Computing Grid.

We are now in its third major release (CRAB3) and this will be the only one supported for Run2.

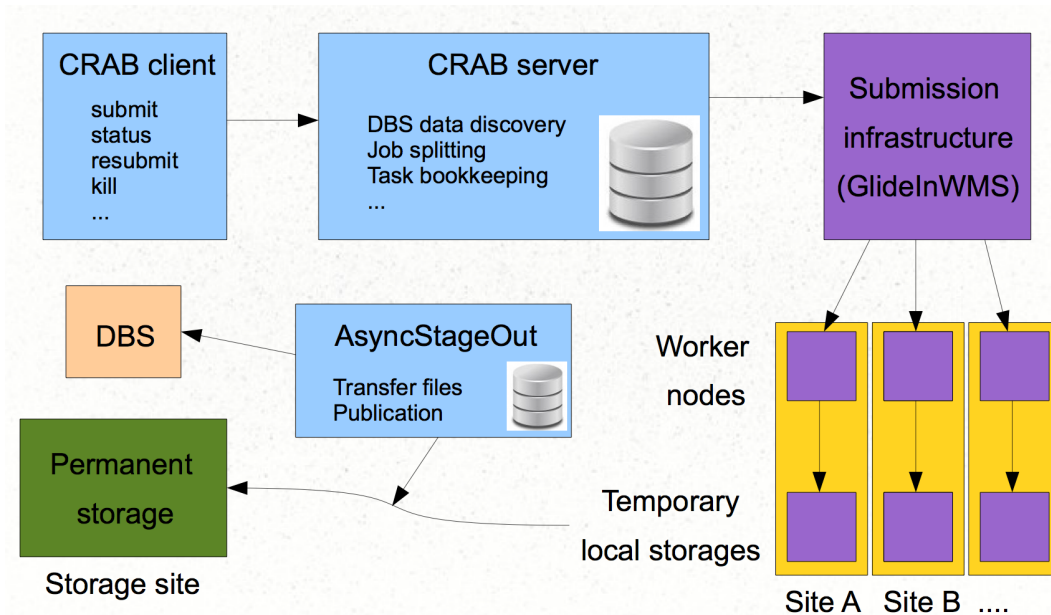

**Tutorial:** <https://indico.cern.ch/event/320672>

**Twiki page:** <https://twiki.cern.ch/twiki/bin/view/CMSPublic/WorkBookCRAB3Tutorial>



# Few practical hooks for the “first steps”



## Where to get help and find info

**First stop, the Workbook!**

<https://twiki.cern.ch/twiki/bin/view/CMSPublic/WorkBook>

Physics Analysis Tool group twiki page:

<https://twiki.cern.ch/twiki/bin/view/CMSPublic/SWGuidePhysicsTools>

## Tutorials

Just finished PAT tutorial:

<https://twiki.cern.ch/twiki/bin/view/CMSPublic/WorkBookPATTutorial>

MiniAOD tutorial:

<https://twiki.cern.ch/twiki/bin/view/CMSPublic/WorkBookMiniAOD>

PAT release recipe for each CMSSW release:

<https://twiki.cern.ch/twiki/bin/view/CMSPublic/SWGuidePATReleaseNotes70X>

Questions about Physics Analysis Tools should be sent to [hn-cms-physTools@cern.ch](mailto:hn-cms-physTools@cern.ch) (please register)

Another source of information is the weekly RECO/AT meeting every Thursday at 5 pm, CERN time.



## Statistics tools

With the complexity of analyses, the statistical interpretation of the results has reached a totally new level at the LHC.

The help of experts in statistics is needed:

- How to evaluate errors and correlations when I use an MVA of an MVA of an MVA? (we have analyses needing this approach)
- What should I use for settings limits?
- Is CLs ok? Should I use frequentist or Bayesian approaches?
- How I can be sure my limits cover? (i.e. 95% CL is really 95%?)
- What kind of error should I use when no event is surviving?
- .....

These are just some of the common issues that are continuously popping up. If you are not sure about them, don't embark in a DIY statistical approach but contact our **Statistics Committee!**



## The CMS Statistics Committee

### SC members

Tommaso Dorigo (chair)

Sudeshna Banerjee

Mingshui Chen

John Conway

Bob Cousins

Luc Demortier

Ulrich Heintz

Louis Lyons

Jochen Ott

Fedor Ratnikov

Michael Schmitt

Igor Volobouev

- 12 CMS members with interest in statistics who **work to help collaborators** produce results using recommendable statistics procedures
- The CMS Statistics Committee forms **recommendations on statistical issues** relevant to CMS physics analyses  
The members of the committee also act as **consultants to CMS collaborators seeking input** on specialized statistics issues.
- The committee has a useful twiki page which can be found at <https://twiki.cern.ch/twiki/bin/view/CMS/StatisticsCommittee>
- It is also a good idea to subscribe to the “Statistics Discussions” Hypernews: low-rate, high S/N threads; currently 640 subscribers



# Few practical hooks for the “first steps”



## The CMS Statistics Committee

SC members **take 3-week shifts** to be “on call”, answering statistics questions (sent through “[Statistics discussions](#)” Hypernews or the [cms-statistics-committee@cern.ch](mailto:cms-statistics-committee@cern.ch) mailing list) or directing collaborators to relevant resources

The shifter **guarantees a quick initial response** and interfaces the committee in the solution of the problem

### Rapid Response Shifts

The CMS Statistics Committee attempts to answer statistical questions in the shortest possible time. To speed up the process, members engage in rapid interaction with the person asking the question.

The table below allows Statistics Committee members to view shift information. This information is mainly for internal use of the committee and should be submitted through the Hypernews forum or the mailing list [cms-statistics-committee@cern.ch](mailto:cms-statistics-committee@cern.ch). However, please note that when possible, it is more recommendable to get in touch in person, to save time.

Begin date	End date	Member in charge	At CERN ?
Jul 28 <sup>th</sup> 2014	Aug 17 <sup>th</sup> 2014	Sudeshna Banerjee	
Jul 7 <sup>th</sup> 2014	Jul 27 <sup>th</sup> 2014	John Conway	
Jun 16 <sup>th</sup> 2014	Jul 6 <sup>th</sup> 2014	Mingshui Chen	yes
May 26 <sup>th</sup> 2014	Jun 15 <sup>th</sup> 2014	Louis Lyons	No
May 5 <sup>th</sup> 2014	May 25 <sup>th</sup> 2014	Bob Cousins	

- The SC **reviews every CMS paper draft** to check the exposition of the statistical treatment of the data and the reporting of results.
- The SC also created a **questionnaire** that analysts need to fill before approving a physics result. This aims at steering analyzers away from faulty techniques or ad-hockery which would otherwise result in large losses of time during later analysis review stages.
- The CMS Statistics Committee **meets via vidyo every 2 weeks** to discuss questions by collaborators, papers, questionnaires, and to form recommendations on statistics issue. **Meetings are open to all.**

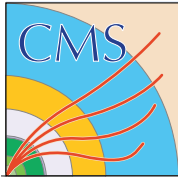

(Biased)  
Run2 physics highlights  
based on Run I results



Theorists have suggested what is the “minimal” effort approach assuming what we observe is the “Higgs”, SuSy is there and it is the solution to the Hierarchy problem:

- the mass of the Higgs gets quadratically divergent loop corrections:

$$\delta m^2_H = \delta m^2_H{}^{top} + \delta m^2_H{}^{W,Z} + \delta m^2_H{}^{self}$$

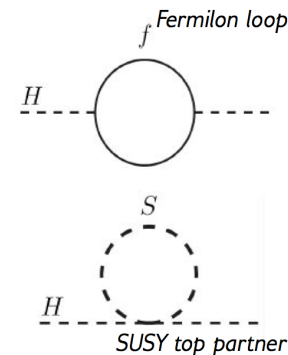

- we need a “natural” cancelling term with negative contribution:  
arXiv:1110.6926, J. Ruderman et al.

$$\delta m^2_{H_u} = -\frac{3y_t^2}{8\pi^2} (m_{Q_3}^2 + m_{u_3}^2 + |A_t|^2) \ln\left(\frac{\Lambda}{m_{\tilde{t}}}\right)$$

- but in turns, a light stop requires a not too heavy gluino (two loop corrections):

$$\delta m^2_{H_u}|_{gluino} = -\frac{2}{\pi^2} y_t^2 \left(\frac{\alpha_s}{\pi}\right) |M_3|^2 \log^2\left(\frac{\Lambda}{\text{TeV}}\right)$$

- + additional constraints on Higgsinos.....

Compulsory Natural SUSY

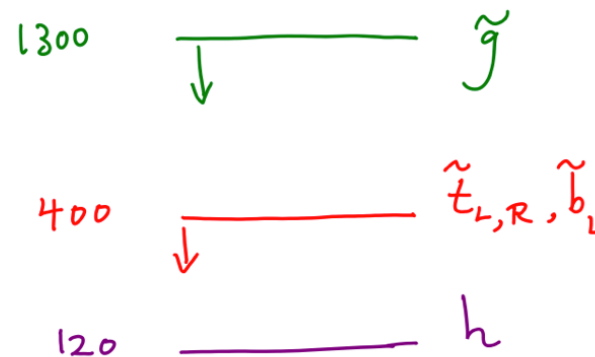

Unavoidable tunings:  $\left(\frac{400}{m_{\tilde{t}}}\right)^2, \left(\frac{4m_{\tilde{t}}}{M_{\tilde{g}}}\right)^2$

Standard SuSy searches are based on characteristic signatures: large missing energy (stable LSP), b-tag and multiple leptons, multi-jet (...) appearing from decay cascades.

Broad/generic searches in CMS have not given positive results so far.

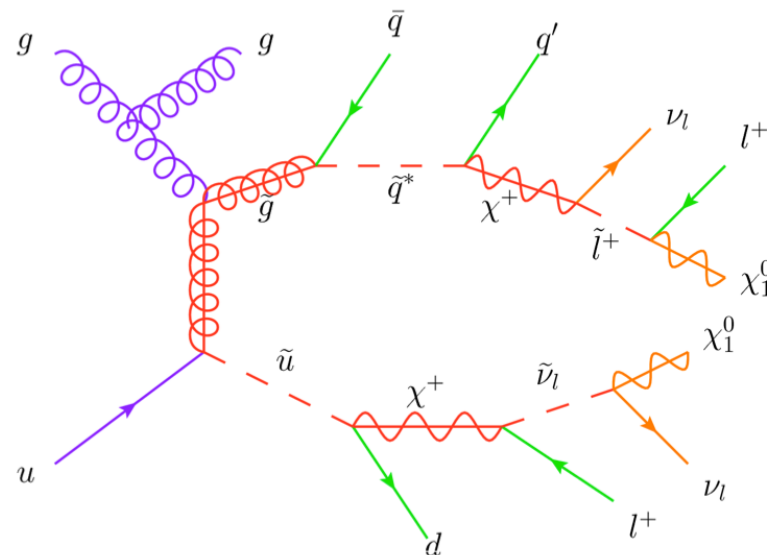

Dedicated search for stop and sbottom after the “Higgs” discover (in gluino decays and direct production) are based on low mass differences and low mass LSP:

- low missing energy
- soft leptons
- boosted top (jet substructure)
- long-lived particles, stopping tracks

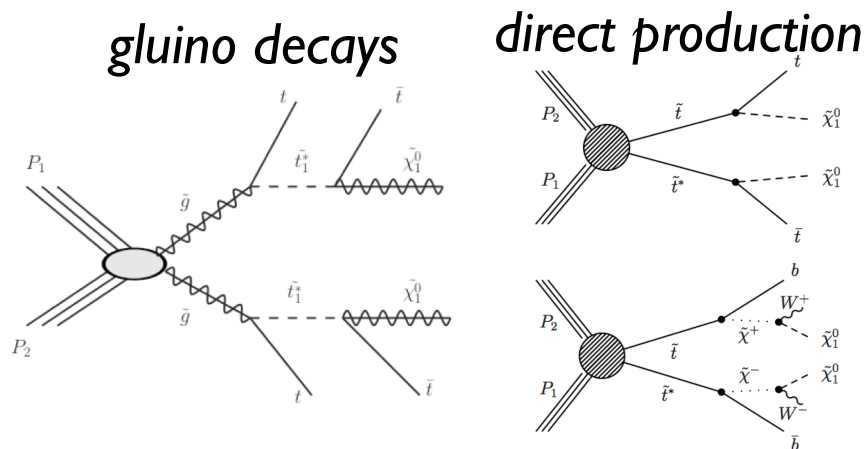

While a “natural” solution to the hierarchy problem looks elegant and appealing, there is absolutely no other fundamental reason to believe it is the only possible solution (if a solution is really needed).

- Nature might be **extremely fine tuned** (actually many think there is no absolute scale to define a fine tuning...)
- There is no need to be **R parity conserving**. We would miss a good candidate for dark matter but nobody ordered that SuSy solves both the hierarchy and the dark matter problems.

- More exotic BSM models (**extra dimensions, new gauge forces (Z', W'), Hidden sectors, unparticles**) might completely change the picture

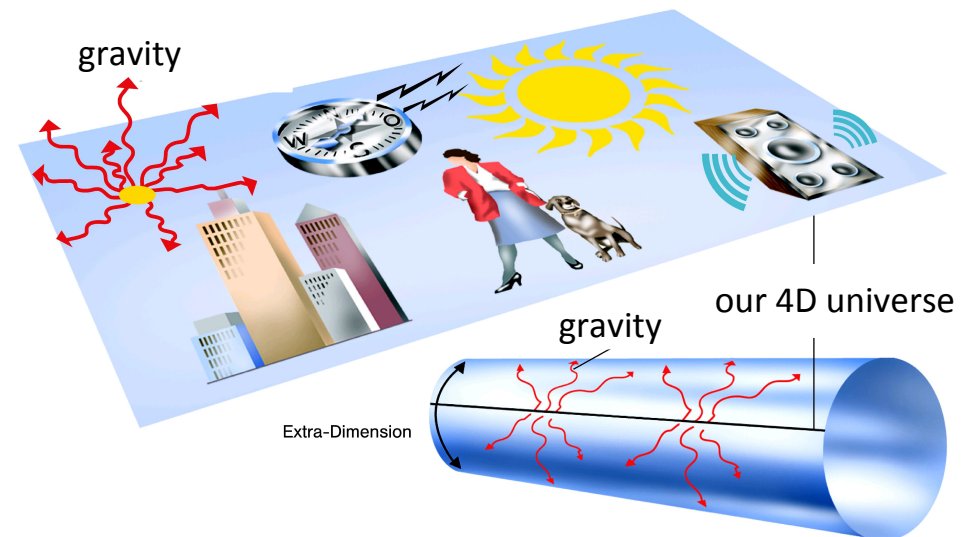

CMS has a very large program in EXOTICA searches (this includes B2G analyses).

In general these use the most demanding “object” id/reco, particularly important for Run2:

- TeV range muons and electrons for W', Z' searches
- abnormal timing/tracking (long-lived particles, displaced vertices)
- highly boosted jets (monojet, etc.)

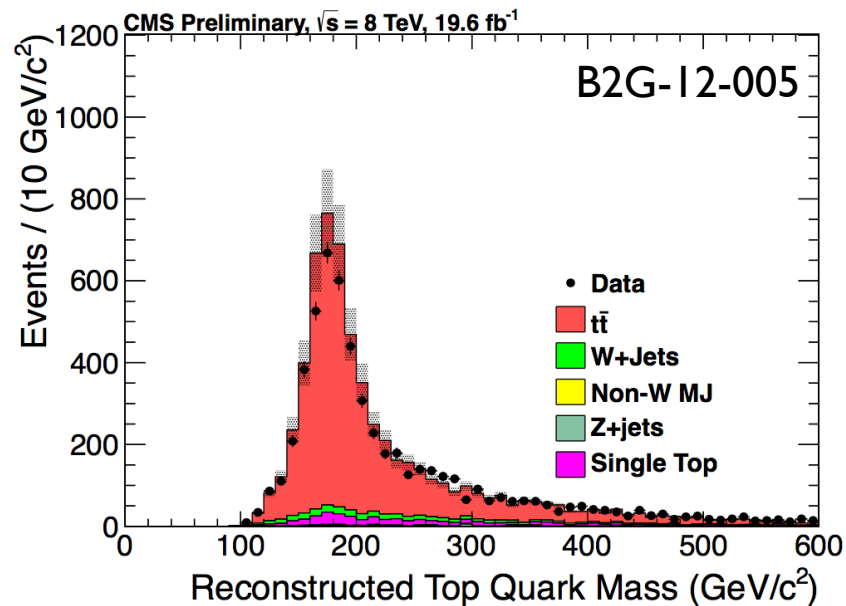
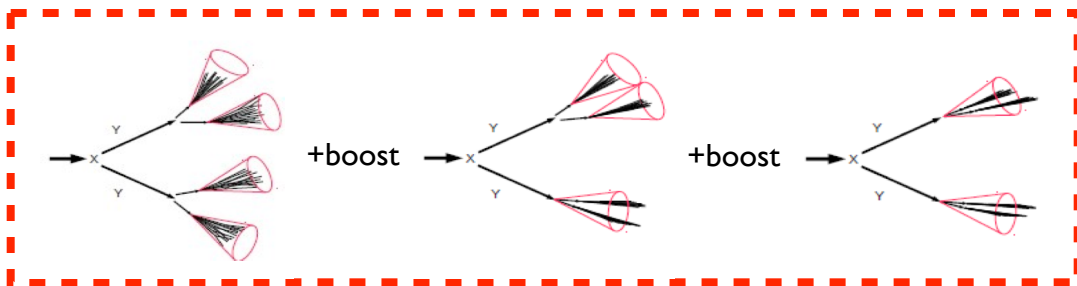

We should not forget that Standard Model precision physics **IS** a discovery tool:

- history has shown us that indirect searches via SM tests are a **powerful way to get hints on new physics**
- with the discovery of the Higgs (assuming it is the SM Higgs) we have **closed the parameter space of the SM** and precision measurements become even **more powerful**
- in addition, they represent an intrinsic **“calibration/validation”** tool for all our analyses.

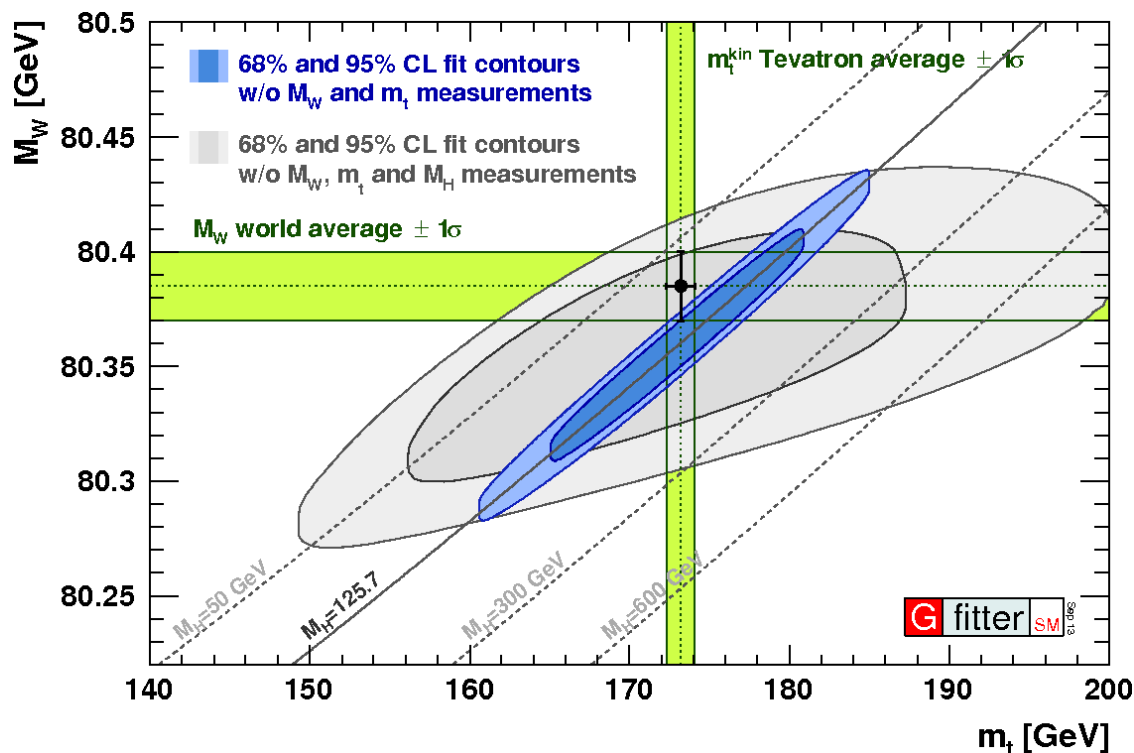

- ▶ We (LHC/CMS) are already doing pretty well in  $M_{\text{top}}$ .
- ▶  $M_W$  might be the next (big) challenge. Tevatron did great and much better than expected.
- ▶ Need to keep an eye on it and prepare for Run2!

The road is already well planned (after our 8 TeV data).

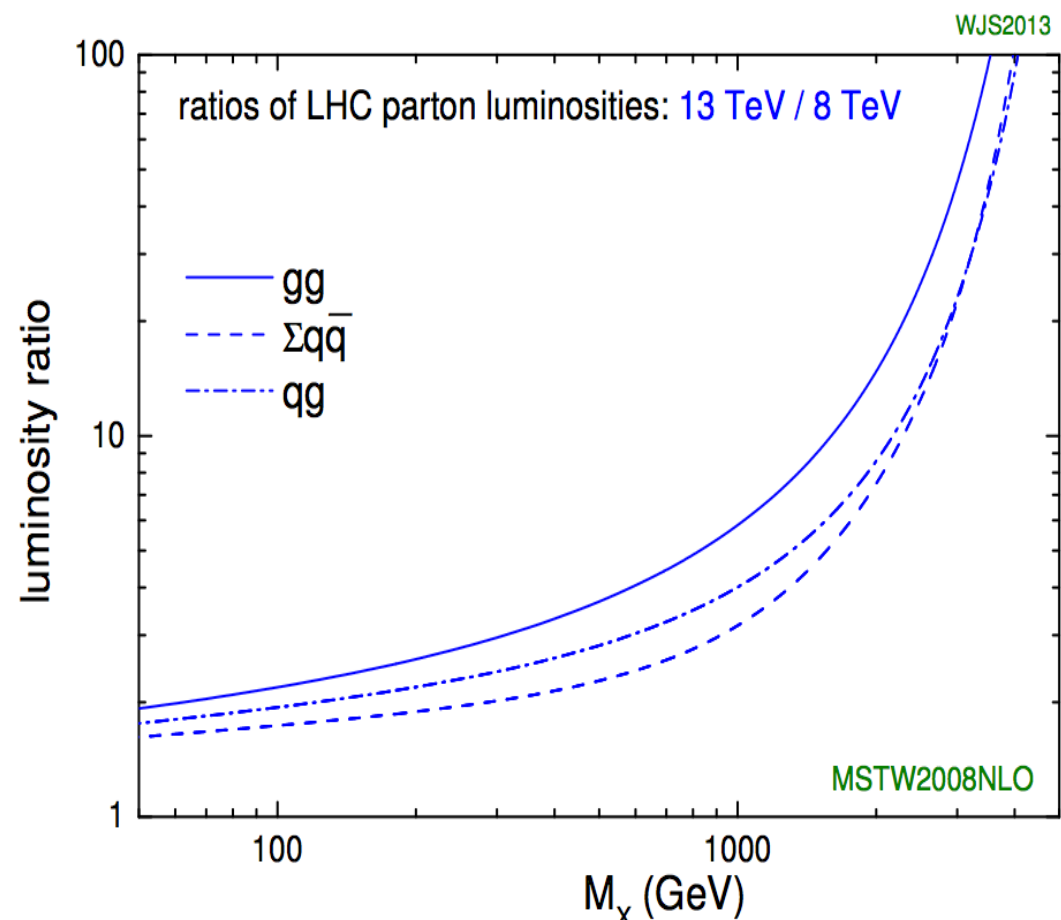

- direct extrapolation from Stirling plot (i.e. when will we exceed the 8 TeV discovery potential?)
- Explore corner of phase space left hidden in our 8 TeV data (low missing  $E_t$ , low  $p_t$  leptons, long-lived, etc.) but for this we need a lot of ingenuity and flexibility at trigger and data processing level
- Precision physics:
  - test that bkg for searches are well modelled (including our MC tuning)
  - Indirect searches.

A different way to look at the Stirling plot:

how much luminosity @13TeV is needed to equal the 8 TeV discovery potential (a really approximate view!)

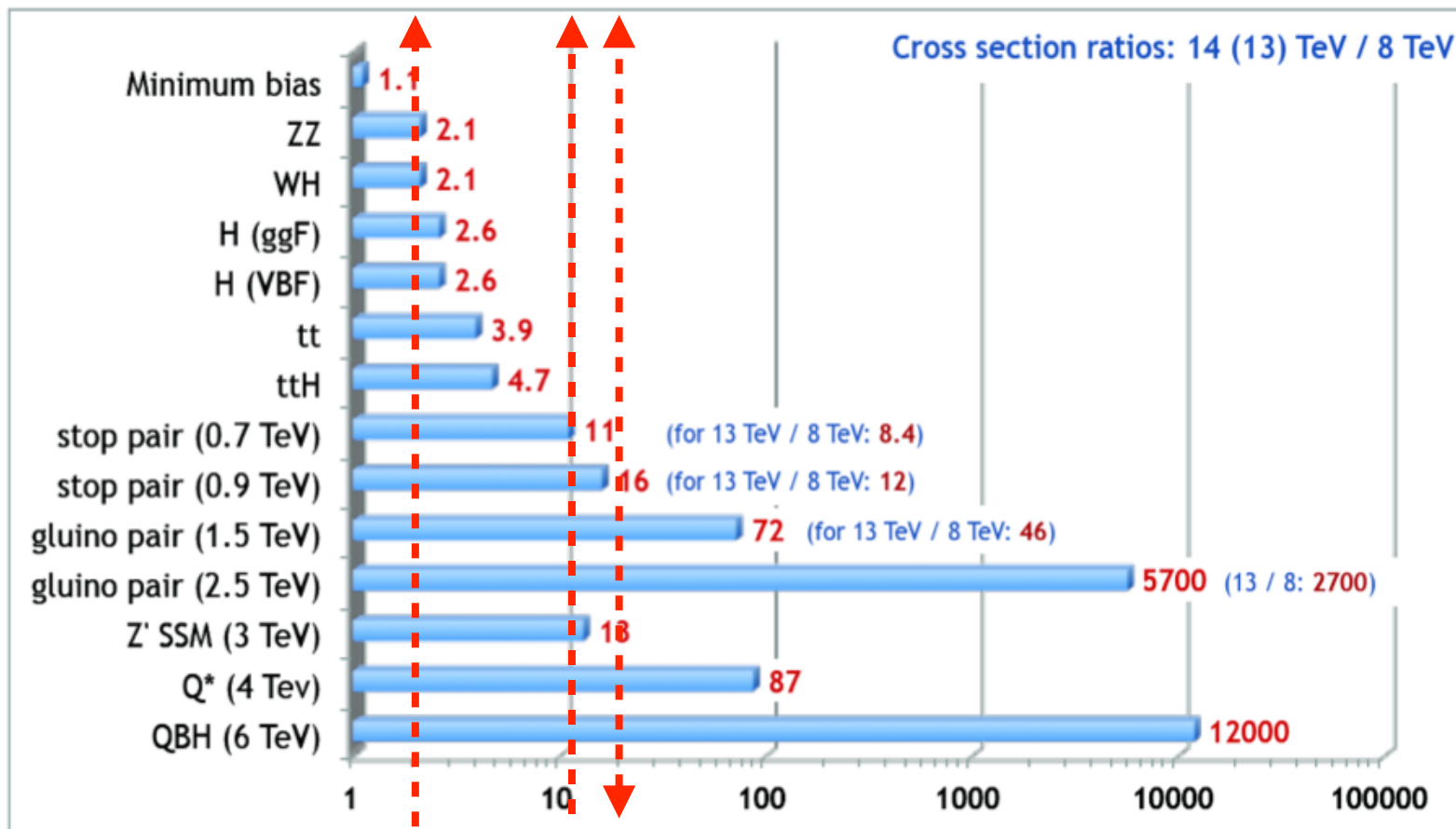

1 fb-1 equivalent reach to Run I

2 fb-1 equivalent reach to Run I

10 fb-1 equivalent reach to Run I

Going backward along the line of big cross section multipliers

$Z' \rightarrow \mu\mu$  (M= 3 TeV)

we will be in an unexplored region with 1-2 fb<sup>-1</sup> !

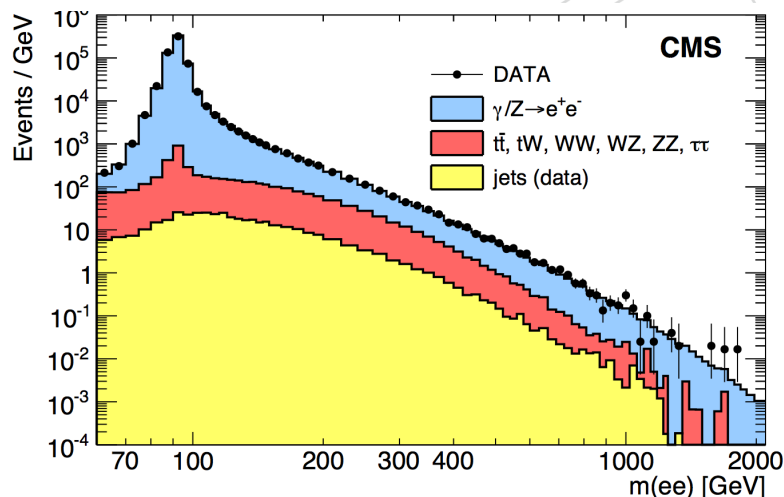
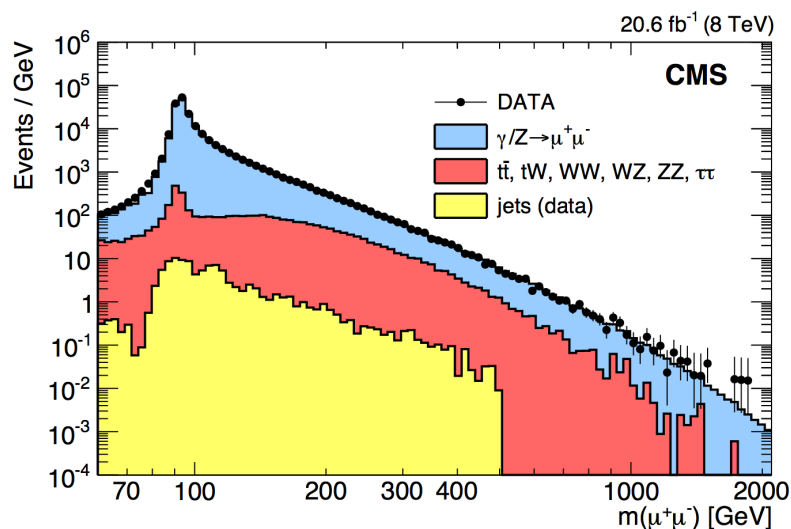
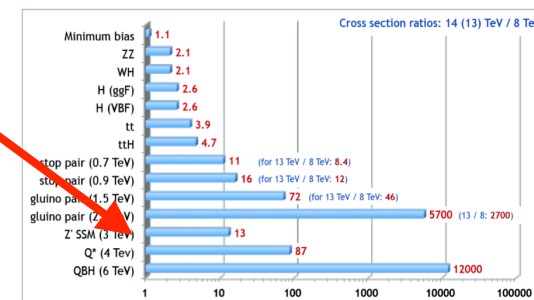

Needs:

- high energy lepton id and reco
- boosted topologies (for other channels)

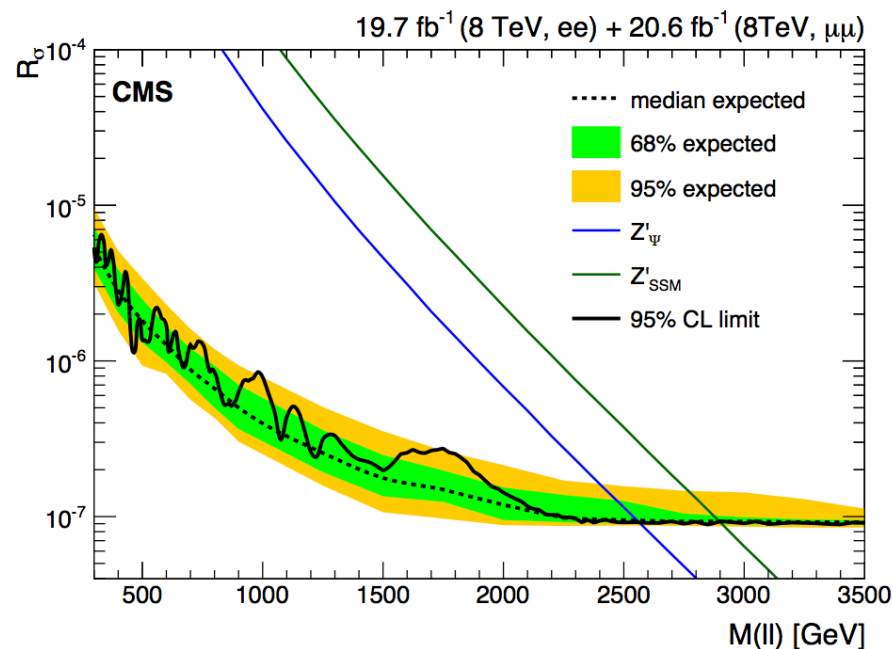





# Some suggestions for Run2



Going backward along the line of big cross section multipliers

gluino pair  $\rightarrow$  x46 ( $M = 1.5$  TeV)

we will be in an unexplored region with  $0.5 \text{ fb}^{-1}$  !

Need to understand (very early in the run):

- missing  $E_t$ , lepton efficiencies
- btag, ttbar background

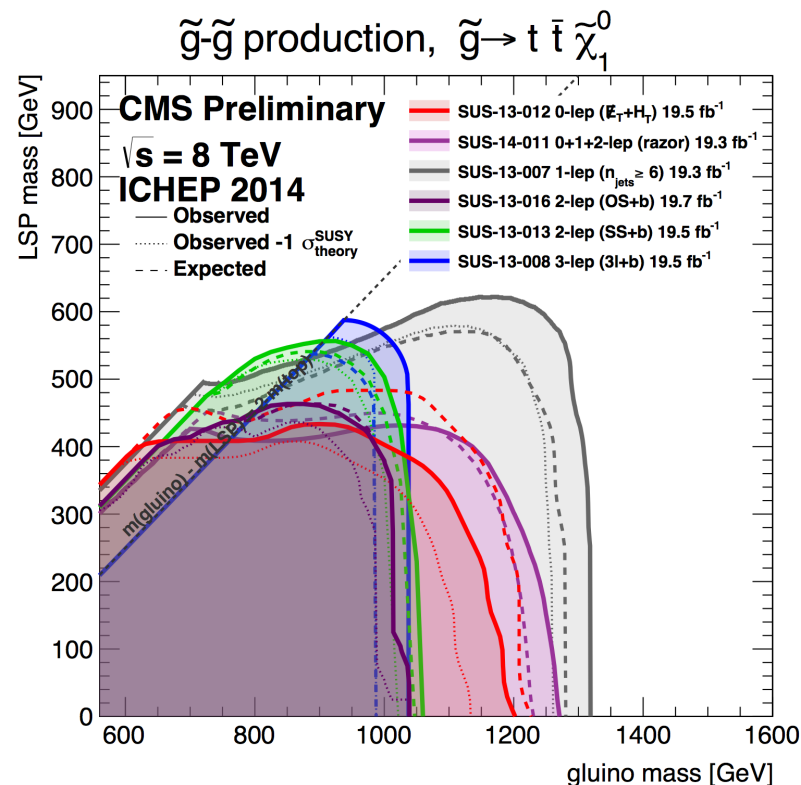
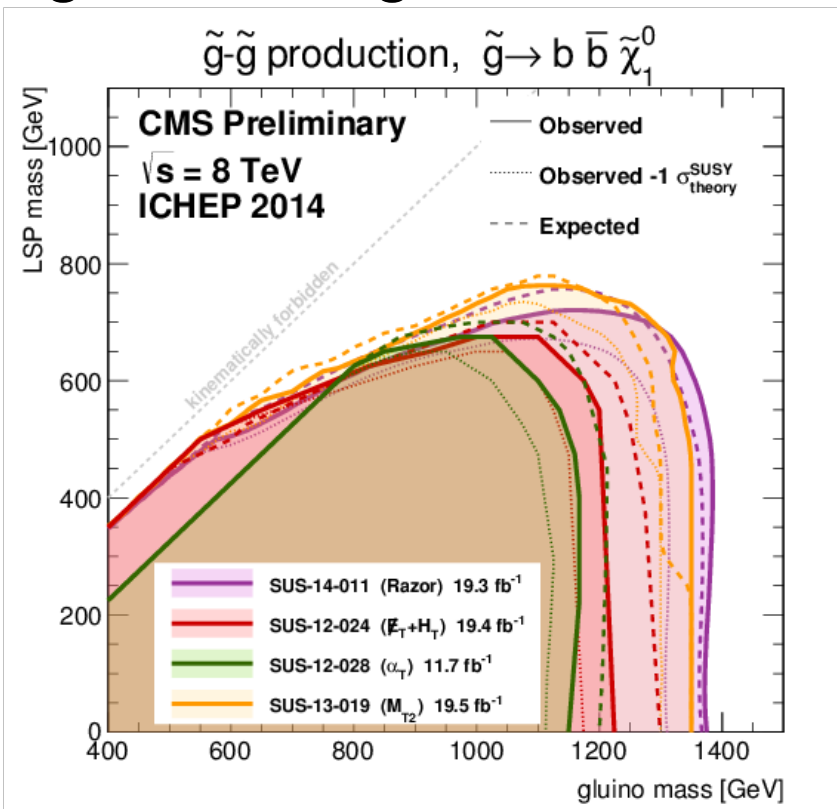
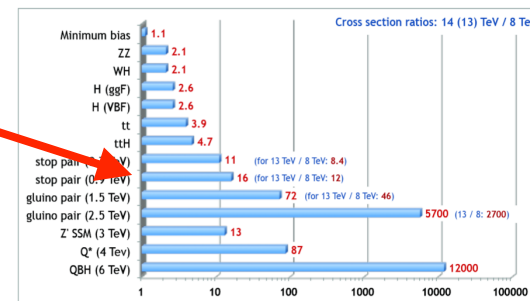



# Some suggestions for Run2



Going backward along the line of big cross section multipliers

stop/sbottom pair  $\rightarrow$  x6 (M = 0.7 TeV)

we will be in an unexplored region with  $4 \text{ fb}^{-1}$  !

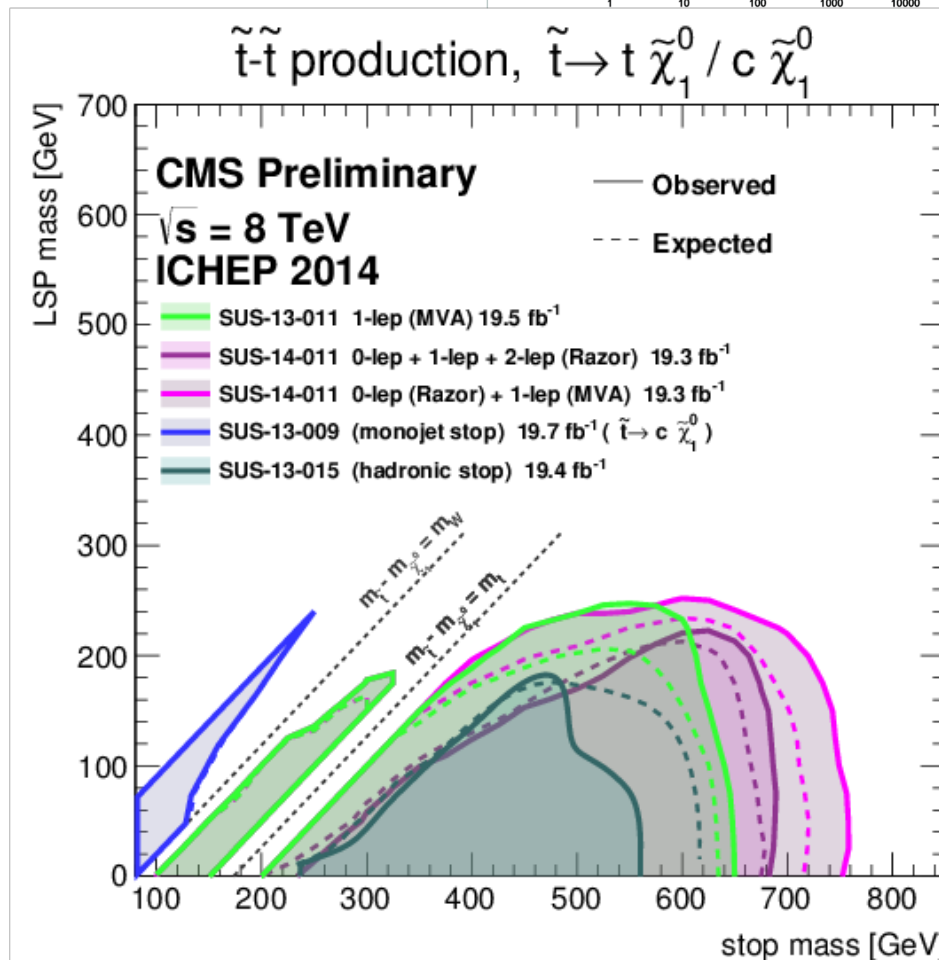
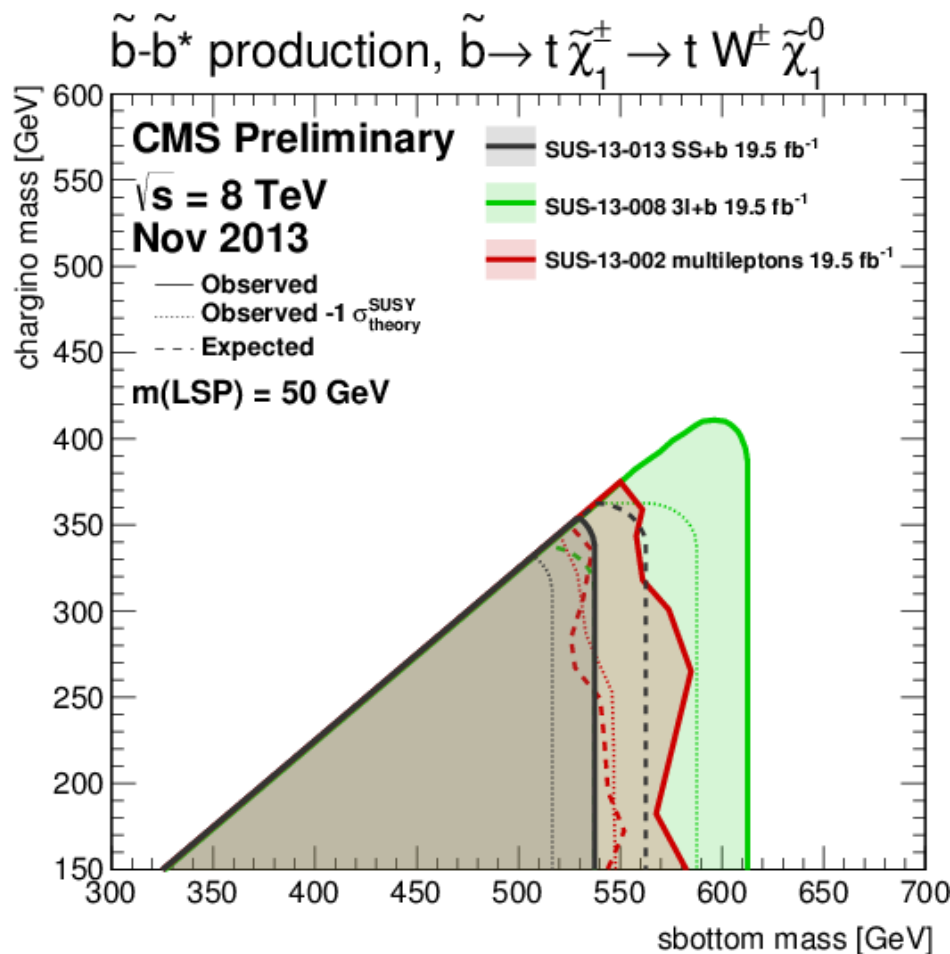
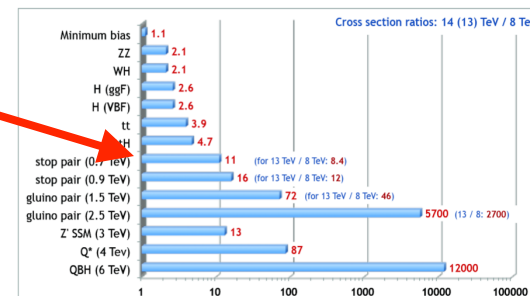

Going backward along the line of big cross section multipliers

**ttH → x4**

ttH can probably pass the “observation” threshold already with  $\sim 10\text{fb-I}$  @13TeV

The other Higgs process will get a boost around 2x (i.e. need to wait  $\sim 40\text{fb-I}$  to equal our current knowledge)

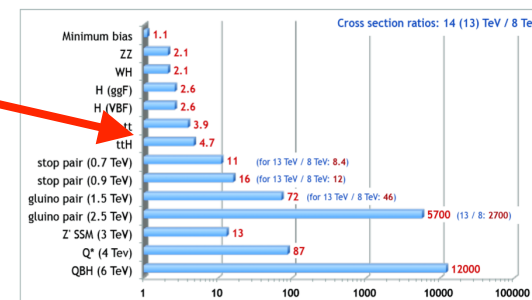

Experimentally extremely challenging (all possible final states considered including multileptons!)

ttH Channel	Measured $\mu$	95% CL upper limits on $\mu = \sigma / \sigma_{SM}$ ( $m_H = 125.6$ GeV)				
		Observed	Observed	Median Signal-injected	Expected Median	Expected 68% CL range
$\gamma\gamma$	$+2.7^{+2.6}_{-1.8}$	7.4	5.7	4.7	[3.1, 7.6]	[2.2, 11.7]
$b\bar{b}$	$+0.7^{+1.9}_{-1.9}$	4.1	5.0	3.5	[2.5, 5.0]	[1.9, 6.7]
$\tau_h\tau_h$	$-1.3^{+6.3}_{-5.5}$	13.0	16.2	14.2	[9.5, 21.7]	[6.9, 32.5]
4l	$-4.7^{+5.0}_{-1.3}$	6.8	11.9	8.8	[5.7, 14.3]	[4.0, 22.5]
3l	$+3.1^{+2.4}_{-2.0}$	7.5	5.0	4.1	[2.8, 6.3]	[2.0, 9.5]
Same-sign 2l	$+5.3^{+2.1}_{-1.8}$	9.0	3.6	3.4	[2.3, 5.0]	[1.7, 7.2]
Combined	$+2.8^{+1.0}_{-0.9}$	4.5	2.7	1.7	[1.2, 2.5]	[0.9, 3.5]

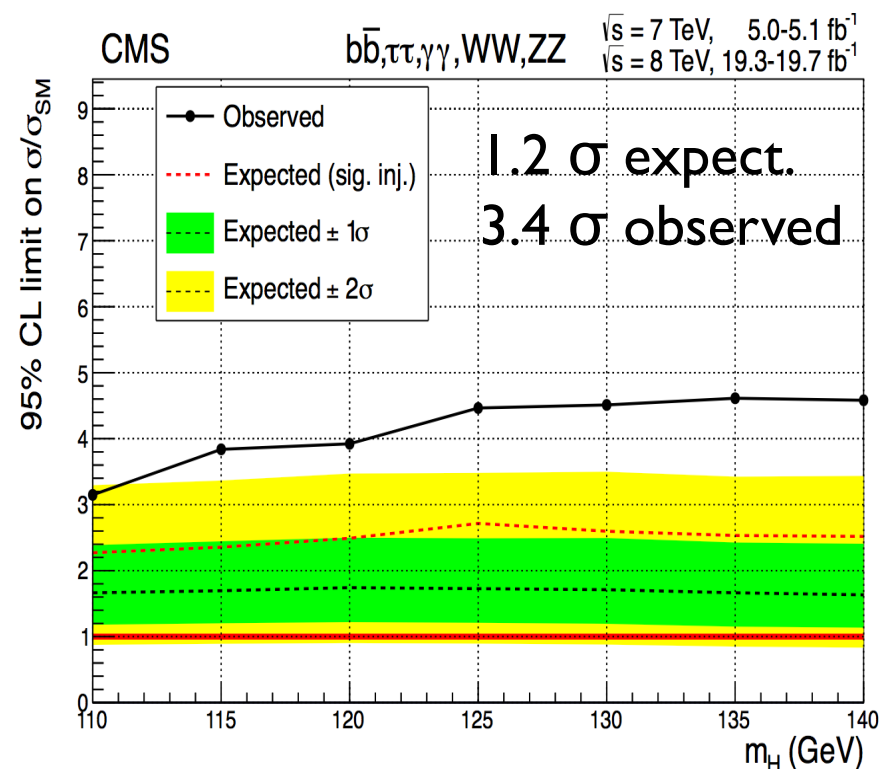

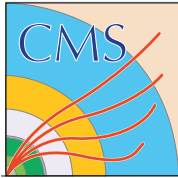

## SM/Precision Physics High Priority Analysis

### SMP+FSQ+BPH:

- integrated lumi is not an issue here, cross section will be high enough.
- Essential is a low PU run early both for physics analyses (inclusive X-sec, etc.) and for MC tuning as we have done in 2009/2010. Only a (very) low int. lumi is needed!
- inclusive Xsec (W, Z, VV) accessible with 0.1-1.0fb<sup>-1</sup>
- aQGC limits, VV scattering need > 5 fb<sup>-1</sup>

### TOP

- first ttbar X-sec can be obtained with few pb<sup>-1</sup>.
- important to develop a dynamical trigger strategy: simple paths up to the 1st fb<sup>-1</sup>, more complex (b-tag, MET, combined, etc.) for later on.

### HIG

- “re-discovery” with first 5-10 fb<sup>-1</sup> (but BSM heavy Higgs searches probably earlier).
- maintaining trigger performance is a must



## Searches High Priority Analyses

### B2G:

- Crucial for B2G to develop non-isolated lepton trigger and merged hadronic tops (boosted top)
- priority analyses:
  - $l+j$  and dilepton, single lepton
  - $Z' \rightarrow t\bar{t}$ ,  $W' \rightarrow tb$

### EXO:

- Natural high priority analysis:
  - $Z', W'$
  - di-jet, di-photon
  - $VV$  resonance
- On the trigger side, the long-lived paths should be rethought

### SuSy:

- exceeding 8 TeV reach after 2-5  $\text{fb}^{-1}$  of 13 TeV data
- natural SuSy will still be under the spot ( $M_{\text{gluino}} < 1.5 \text{ TeV}$ ,  $M_{\text{stop}} < 800 \text{ GeV}$ ) but if nothing pops up, next frontier is small mass splitting, long-lived, stealth (a nightmare for trigger)

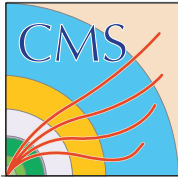

# Conclusions



- This is just a really limited overview of the activities in the Physics Coordination areas
- Hopefully you can find here **at least a hook** from where you can find your way through.
- Please feel free to **contact anybody** you have seen named in these slides for any doubt or question you might have!
- And remember, the best source of info are:
  - ➔ hyper news
  - ➔ twiki pages (especially the WorkBook)
  - ➔ tutorials and CMSDAS schools



# BACKUP

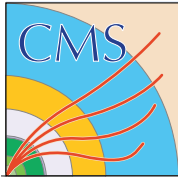

Everything that has to do with conferences in CMS is managed by the CMS Conference Committee (CCC)

#### CCC MEMBERS:

Arnd Meyer (AACHEN-3A) (chair)  
Nicolo Cartiglia (TORINO)  
Monika Grothe (WISCONSIN)  
Vivian O'Dell (FERMILAB)  
Borislav Pavlov (SOFIA-UNIV)  
Gavin Davies (LONDON-IC)  
Kajari Mazumdar (TIFR-EHEP)  
Sergey Petrushanko (MOSCOW-MSU)  
Sung Won Lee (TEXAS-TECH)  
Vincenzo Chiochia (ZURICH-UNIV)  
Ulrich Goerlach (STRASBOURG)  
Jorge Rodriguez (FLORIDA-FIU)

All available talks are advertised on the “Conference announcements” hypernews

([hn-cms-confAnnounce@cern.ch](mailto:hn-cms-confAnnounce@cern.ch))

➔ **Everybody interested in conference talks should read / subscribe to this**

(Only) urgent requests are in addition communicated at the weekly general meeting

General questions / requests: [cms-conf@cern.ch](mailto:cms-conf@cern.ch), but also no problem with approaching us individually

We strive for a transparent and fair distribution of all talks – you can help us in achieving this goal

➔ **Tell us what you like / don't like**

➔ **Nominate for talks! Your colleagues, any deserving CMS member, yourself**



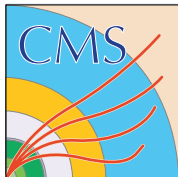

# What next after approval? Conference



Slides from Arnd Meyer

The main gateway to conference presentations is **CINCO**  
(**C**MS **I**Nformation on **C**Onferences):

[https://cms-mgt-conferences.web.cern.ch/cms-mgt-conferences/conferences/conf\\_listing.aspx](https://cms-mgt-conferences.web.cern.ch/cms-mgt-conferences/conferences/conf_listing.aspx)

[https://cms-mgt-conferences.web.cern.ch/cms-mgt-conferences/conferences/pres\\_listing.aspx](https://cms-mgt-conferences.web.cern.ch/cms-mgt-conferences/conferences/pres_listing.aspx)

The screenshot shows the CINCO website interface. At the top, it says "Cms Information on Conferences (CINCO)" and "All Conferences". There is a navigation menu with items: Conferences, Presentations, Speakers, Statistics, Committee, My Info, Help, and Support. Below the menu, it shows the user "Luca Malgeri (CERN)\*" with a "logout" link. The main content area displays "Conferences in" followed by a dropdown menu set to "the next 12 months" and a count of "(86)". There are three filter dropdowns: "Date Type" (set to "Conf. Start"), "Category" (set to "All"), and "Status" (set to "CMS Interest"). Below these filters is a table of conferences:

Conf. Start	Name
21-Jun-15	<b>NN2015</b> , Catania, IT: The 12th International Conference on Nucleus-Nucleus Collisions
21-Mar-15	<b>Moriond/QCD</b> , La Thuile, IT: 50th Rencontres de Moriond on "QCD and High Energy Interactions"
14-Mar-15	<b>Moriond/EW</b> , La Thuile, IT: 50th Rencontres de Moriond on "EW Interactions and Unified Theories"
2-Feb-15	<b>ICPAQGP-2015</b> , Kolkata, IN: The 7th International Conference on Physics and Astrophysics of Quark Gluon Plasma

Any CMS member has a “**profile**” in CINCO:

[https://cms-mgt-conferences.web.cern.ch/cms-mgt-conferences/user\\_info.aspx](https://cms-mgt-conferences.web.cern.ch/cms-mgt-conferences/user_info.aspx)

➔ Please add information (→ biography, contributions, ...), and keep it up to date

Your conference of interest may not (yet) be in CINCO

➔ Enter it yourself, and/or send an email to [cms-conf@cern.ch](mailto:cms-conf@cern.ch)

Don't always wait for “looking for speakers...” announcements

➔ Consider submitting an abstract in CINCO, tailored to your own interests

➔ For some conferences (DIS, Lake Louise, ...), if nobody thought of the topic you might want to talk about, there will be no abstract, and thus no talk, and a missed opportunity...

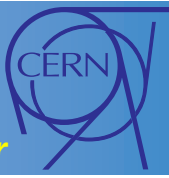
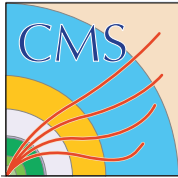

## Few things to keep in mind:

- To be selected for a presentation, speaker candidates need to be “nominated” in CINCO
  - Nomination is by anyone for anyone
- Self-nomination is perfectly fine (and common), additional nomination (convener, supervisor, etc.) particularly useful for younger colleagues
  - Can be deciding factor for otherwise equally deserving candidates
- It does not hurt to have many nominations
- Selection among nominated candidates based on
  - History of (analysis) talks and their importance (e.g. schools/national meetings do not count)
  - Contributions (on analysis, detector, data taking, etc.)
  - Other information in profile (non-tenured, student, job needs, author, ...)
  - Nominations and recommendations