

Computing at CERN

Tim Smith CERN/IT

Our Universe is Yours
Notre Univers est le vôtre



computing, *n.*

Pronunciation:

Brit. /kəm'pjʊtɪŋ/ , U.S. /kəm'pjʊdɪŋ/

1. The action or an instance of calculating or counting;
= computation *n.* 1a.
2. The action or practice of using computers, esp. as a professional or expert; the activity or operation of an electronic computer; (also) = computer science *n.*

An Early “Computer”

- Wim Klein
- Calculating the 73rd root of a 500 digit number took less than 3 minutes...



Computing

- Scientific
 - Compute, Storage, Network
- Technical
 - Design, Operation
- Administrative
 - HR, Finance, Projects
- Desktop
- Collaborative

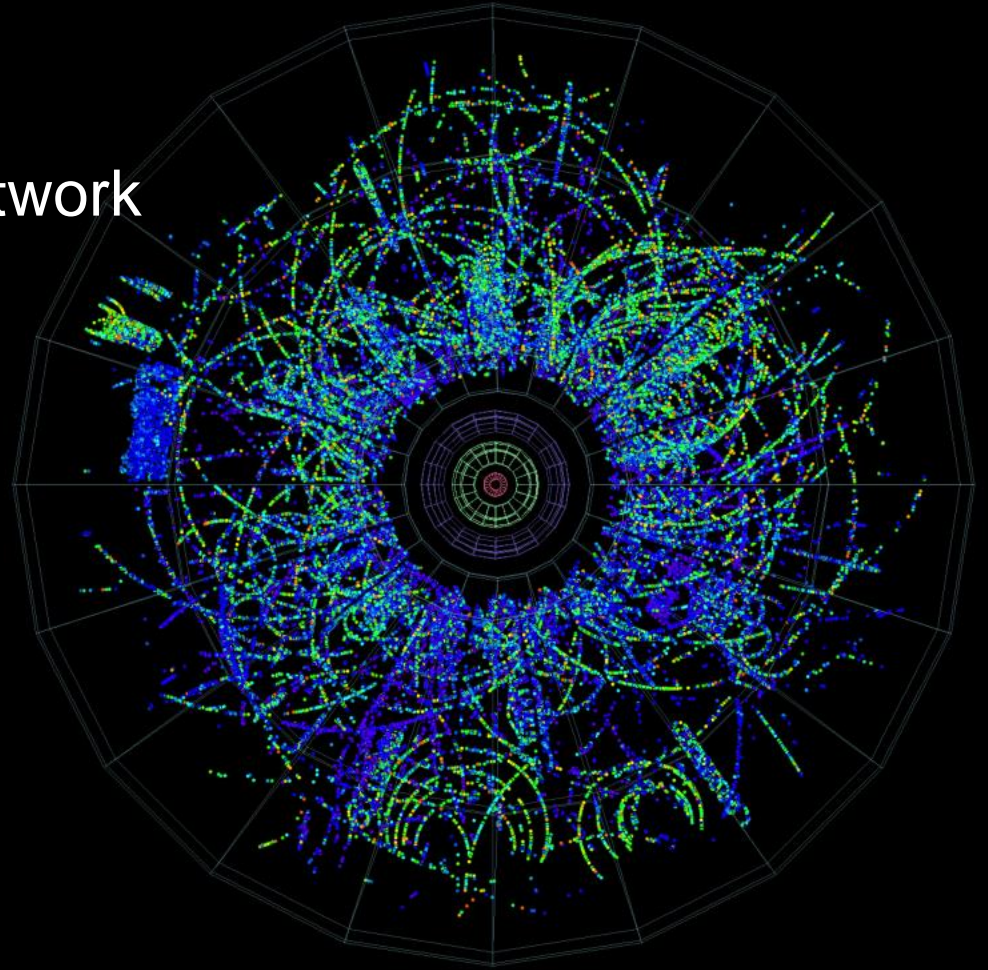

Spark Chambers

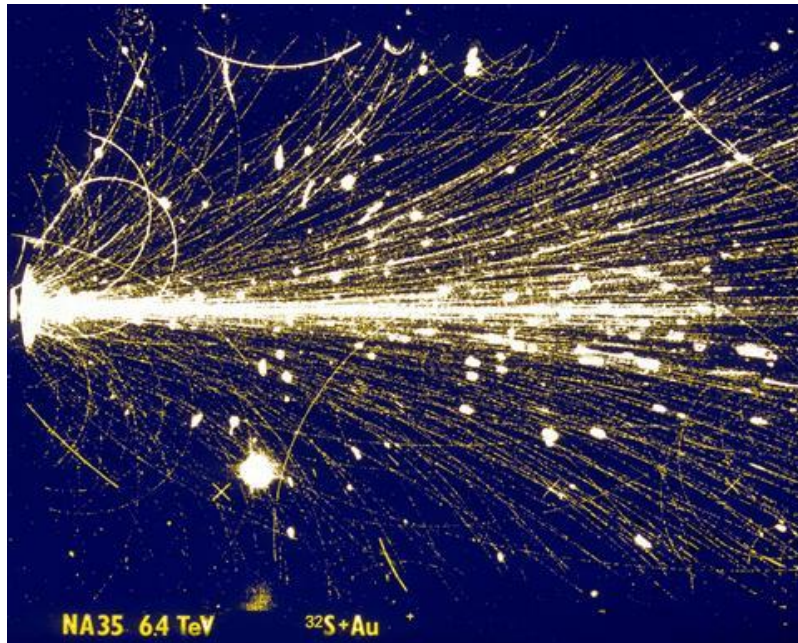

Magnetostrictive readout

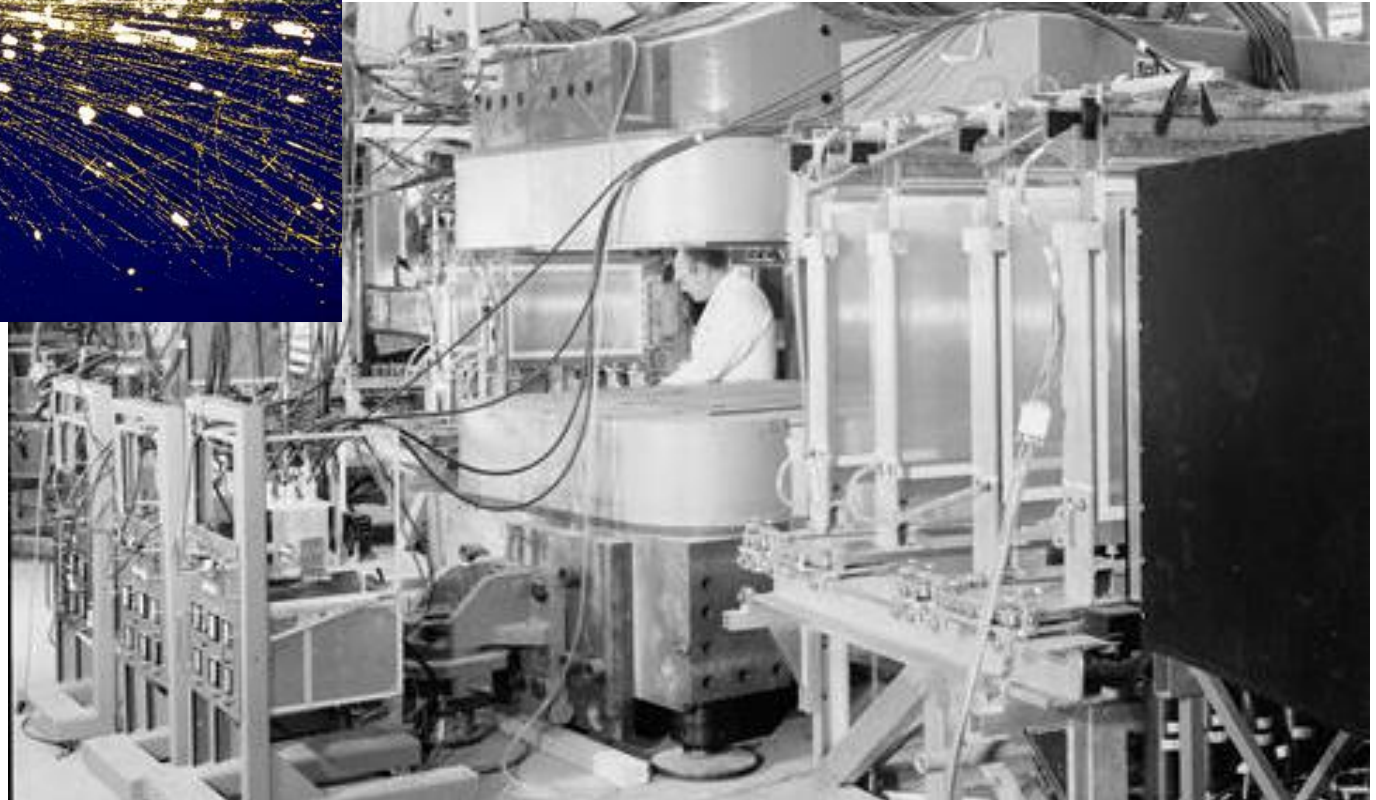

Momentous Events

1960: Vacuum tubes
1965: CDC 6600: #3



Mainframes

New Computer Centre for a New Computer



1983: 2 CDCs and an IBM 3081

Super Computers



1988: Cray XMP

RISC Workstations



Comodity Computing



Farming in a Data Centre



Computing

- Networking

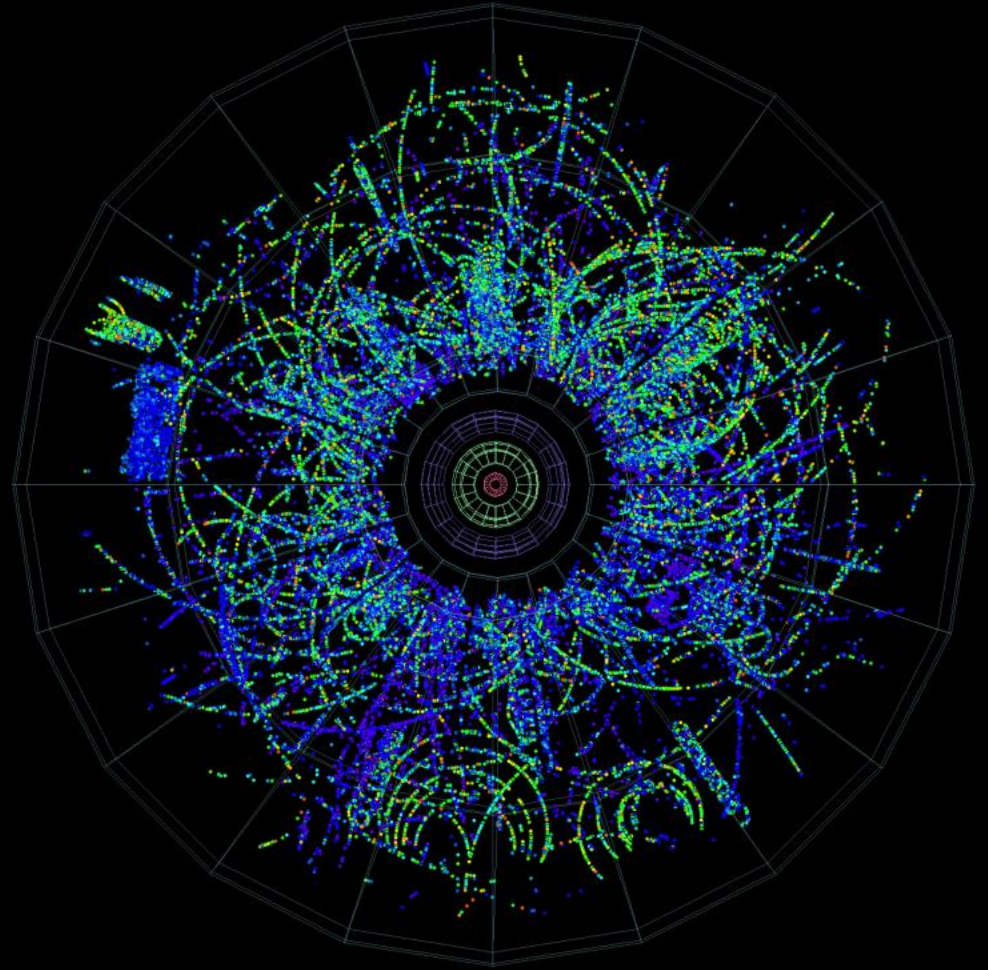

Networking



- Packet-switched network
- 1969 ARPANET
 - US DoD sponsored research at US Universities
 - Aim: communications network to survive a nuclear attack
 - Find next best route if one node obliterated
- 70s and 80s proliferation
 - US: NASA Science Net, CSnet, Energy Sciences Net, NSFnet
 - FR: CYCLADES
 - UK: Mark I, SERCnet
 - Commercial: Tymnet, CompuServ, BITnet, DECnet
 - Protocols: NCP, X.25 (1976), TCP/IP (1982)
 - CERnet



Networking

- Science without borders
 - Data exchange across the iron curtain
 - 1988 first data connection between China and scientific world – IHEP to CERN
- Truly international Internet
 - 1989 first external TCP/IP connection
 - 1990 principle link US-EU from CERN
 - (1.5Mb/s)
 - 1991 80% of the internet capacity installed in Europe for international traffic was terminated at CERN



CERN Internet Exchange Point



Global IS



Computing

- Information Management

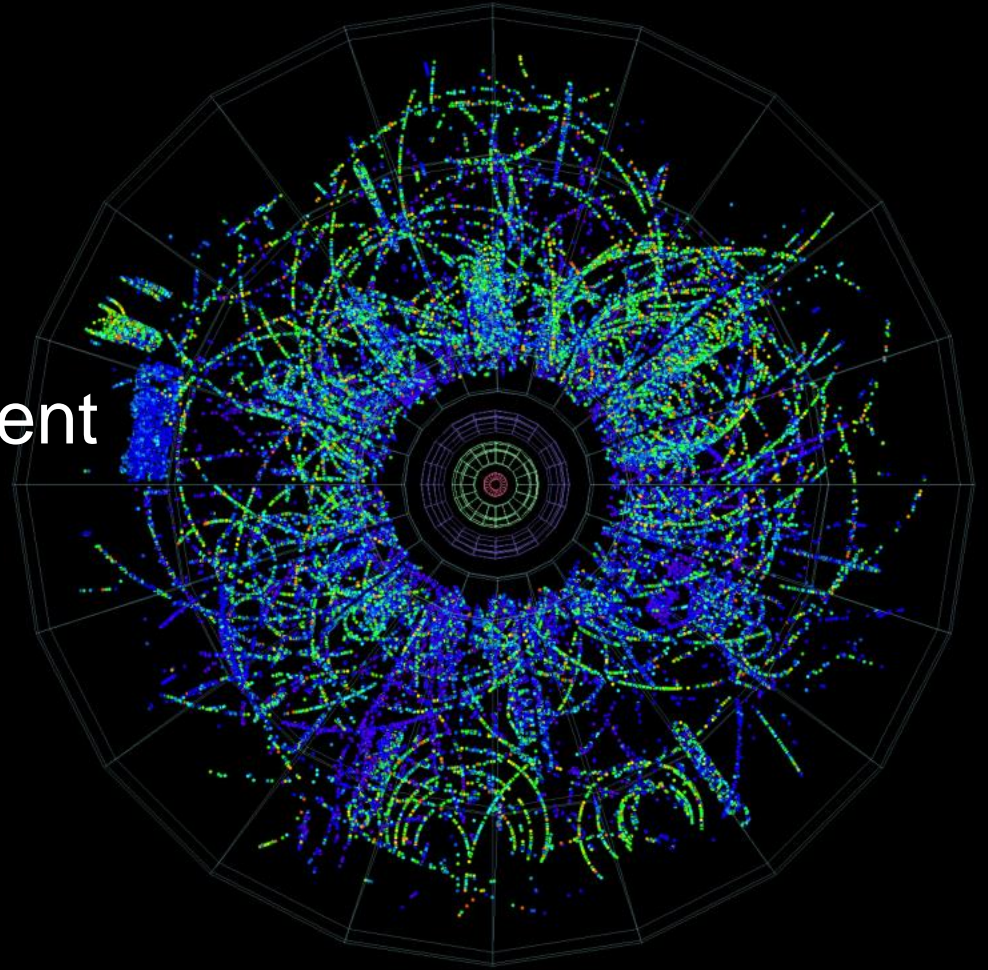

Information Management - *circa 1989*

- Keep track of LHC project and CERN?
 - Researchers turnover ~2 years
- Information about CERN and its experiments
 - Not hierarchical, or centrally controlled
 - A multiply connected web
 - Experts store locally, update independently
 - Community is distributed: remote access
- System to link it all together
- CERN is a model in miniature of the rest of world in a few years time



Vague but Exciting ...

Vague but exciting ...

CERN DD/OC Tim Berners-Lee, CERN/DD
Information Management: A Proposal March 1989

Information Management: A Proposal

Abstract

This proposal concerns the management of general information about accelerators and experiments at CERN. It discusses the problems of loss of information about complex evolving systems and derives a solution based on a distributed hypertext system.

Keywords: Hypertext, Computer conferencing, Document retrieval, Information management, Project control

```
graph TD
    ThisDocument[This document] -- describes --> Proposal[A Proposal X]
    ThisDocument -- describes --> CERNDOC[CERNDOC]
    ThisDocument -- describes --> Hypermedia[Hypermedia]
    ThisDocument -- describes --> Hypermedia[Hypermedia]
    Proposal -- describes --> ComputerConferencing[Computer conferencing]
    Proposal -- describes --> IBMGroupTalk[IBM GroupTalk]
    Proposal -- describes --> VAXNOTES[VAX/NOTES]
    Proposal -- describes --> UNICNews[UNIC News]
    Proposal -- describes --> HierarchicalSystems[Hierarchical systems]
    ComputerConferencing -- describes --> HyperCard[Hyper Card]
    ComputerConferencing -- describes --> ENQUIRE[ENQUIRE]
    IBMGroupTalk -- describes --> UNICNews
    VAXNOTES -- describes --> UNICNews
    HierarchicalSystems -- describes --> CERN[CERN]
    CERN -- describes --> CERNE[C.E.R.N.]
    CERNE -- describes --> DD[DD division]
    CERNE -- describes --> HIS[HIS]
    CERNE -- describes --> OC[OC group]
    OC -- describes --> RA[RA section]
    RA -- describes --> TimBernersLee[Tim Berners-Lee]
    TimBernersLee -- describes --> CommsACFT[Comms ACFT]
```

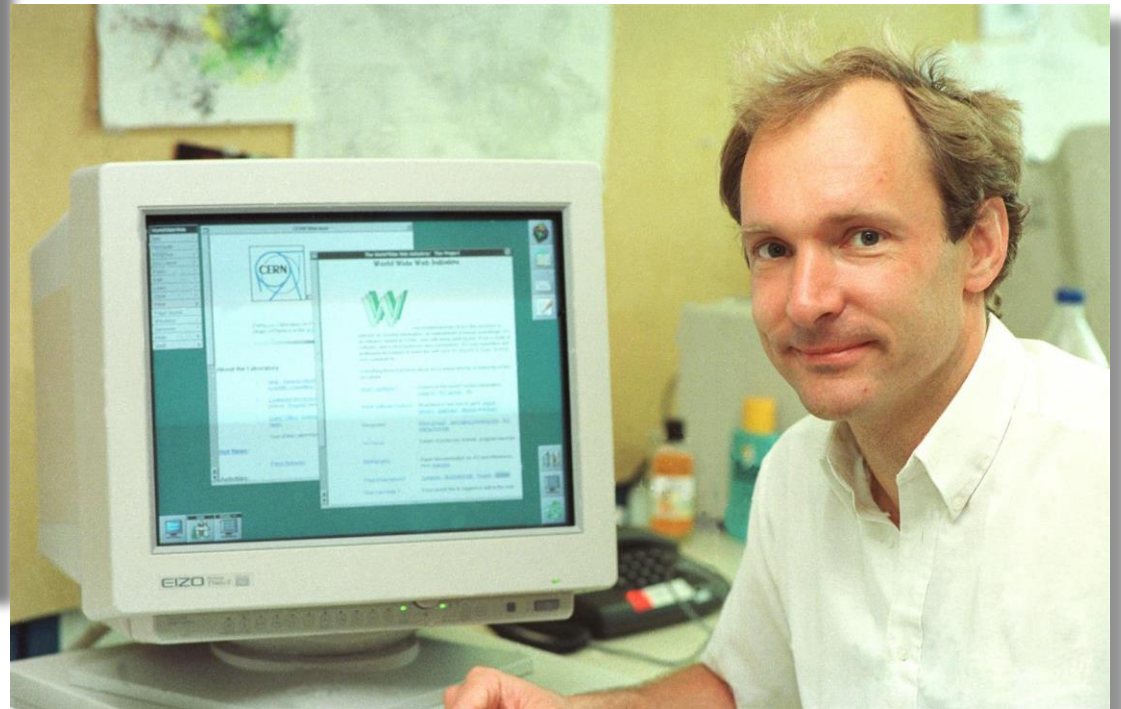

Growth of the Web

- Aug 1991 went public
 - Tim posted project to alt.hypertext and other internet groups



- Dec 1991 First web s
- 1992 rapid expansio
 - Universities and rese

World Wide Web

The WorldWideWeb (W3) is a wide-area [hypermedia](#) information retrieval initiative aiming to give universal access to a large universe of documents.

Everything there is online about W3 is linked directly or indirectly to this document, including an [executive summary](#) of the project, [Mailing lists](#) , [Policy](#) , November's [W3 news](#) , [Frequently Asked Questions](#) .

[What's out there?](#)

Pointers to the world's online information, [subjects](#) , [W3 servers](#), etc.

[Help](#)

on the browser you are using

[Software Products](#)

A list of W3 project components and their current state. (e.g. [Line Mode](#) ,X11 [Viola](#) , [NeXTStep](#) , [Servers](#) , [Tools](#) , [Mail robot](#) , [Library](#))

[Technical](#)

Details of protocols, formats, program internals etc.



Growth of the Web

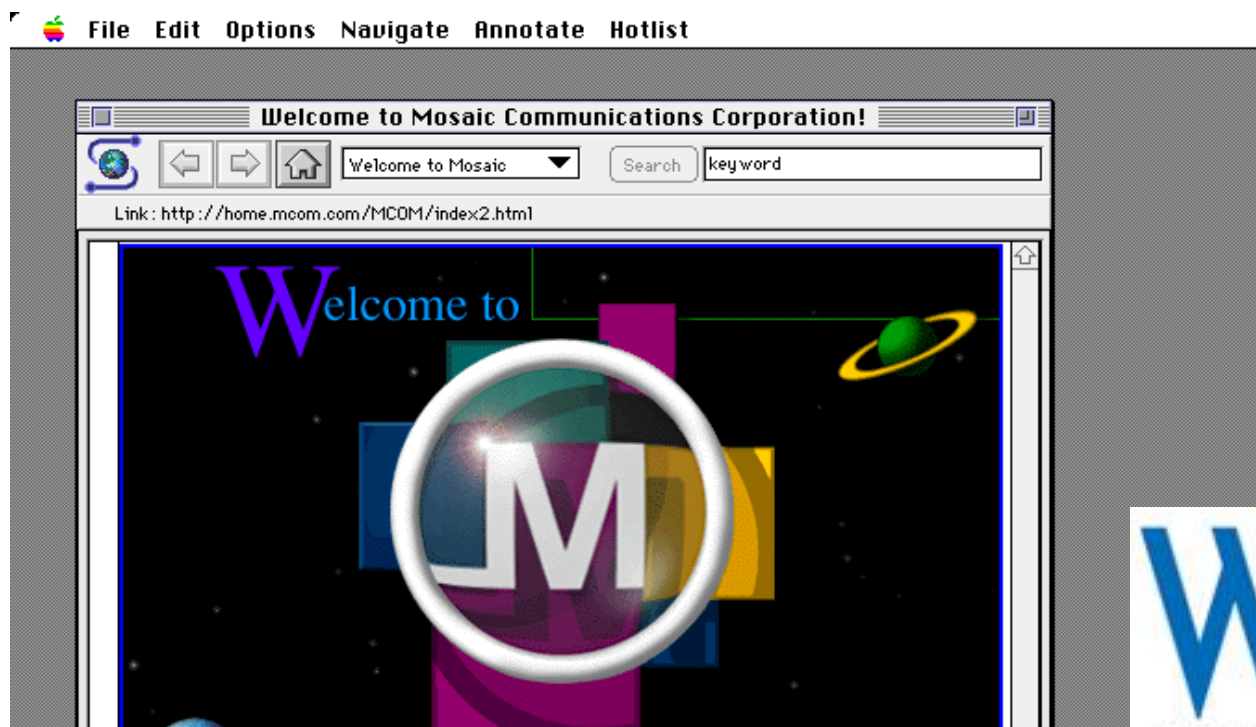

- 1993 rapid expansion across the world
 - National Center for Supercomputing Applications (NCSA) at the University of Illinois released its Mosaic browser

Computing

- The LHC Era

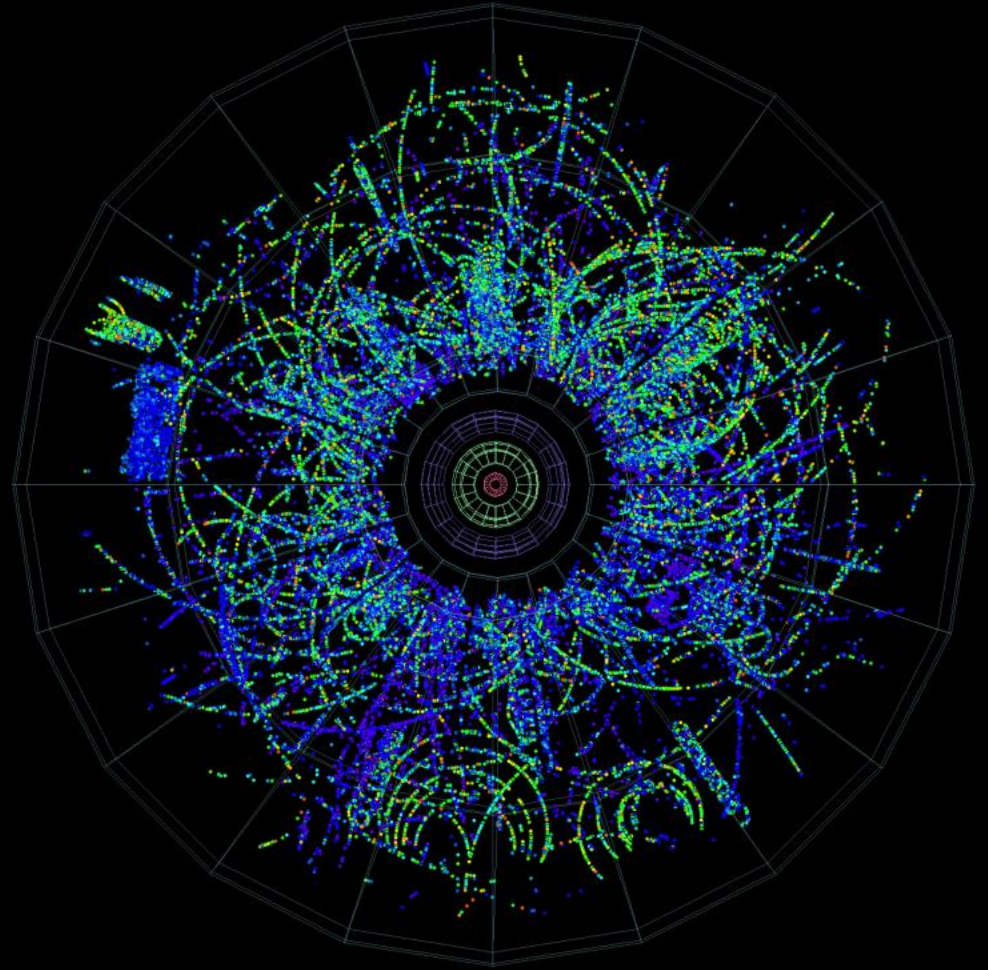

The LHC Data Challenge

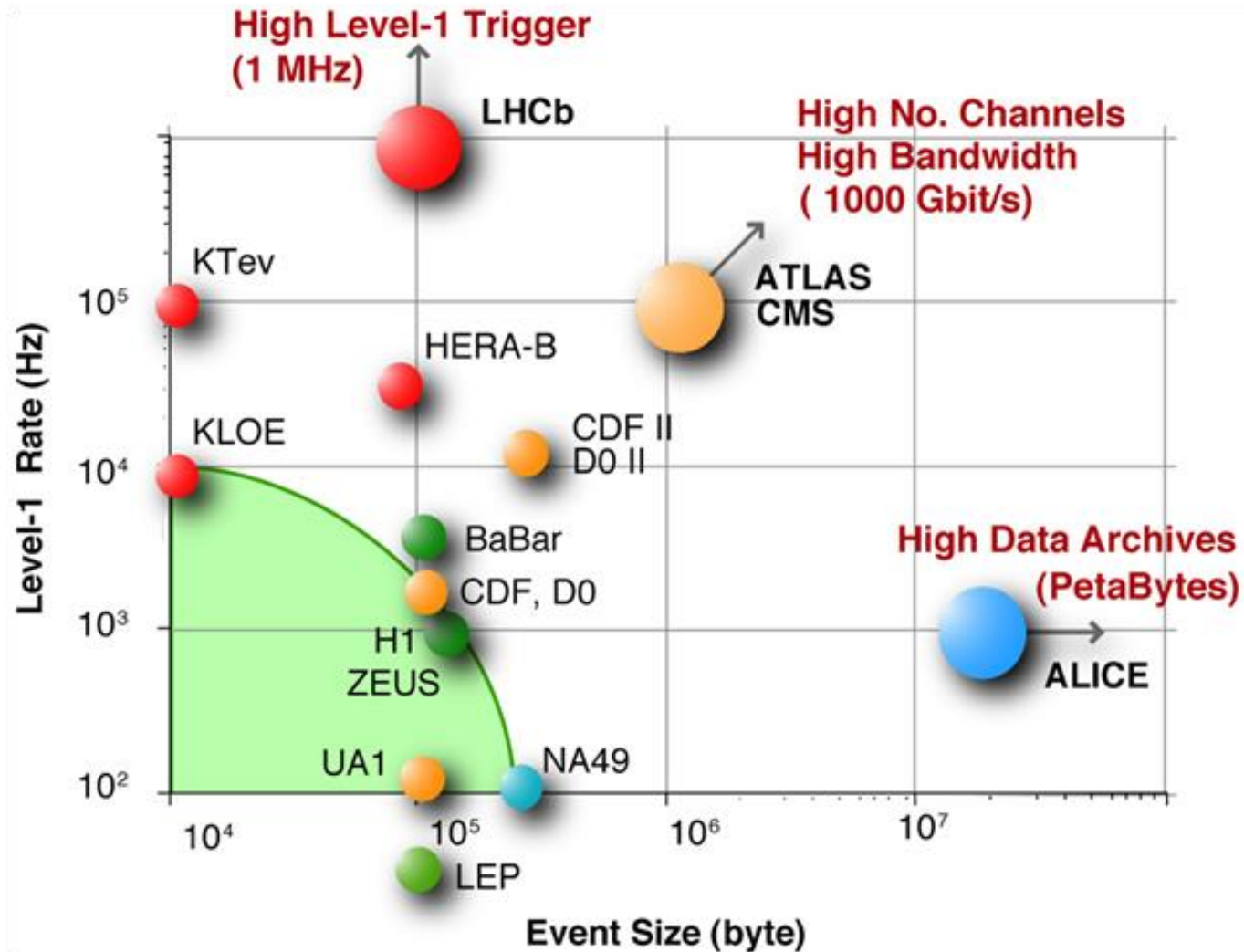

Big Data !

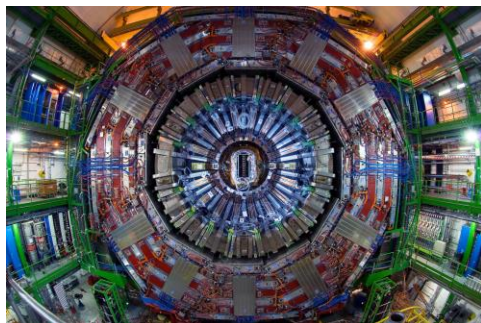

150 million sensors
Generating data 40 million times per second

→ **Peta Bytes / sec !**



Trigger
Select 100,000 per second

→ **Tera Bytes / sec !**



HLT / Filter
Select 100 per second

→ **Giga Bytes / sec !**

Primary Storage

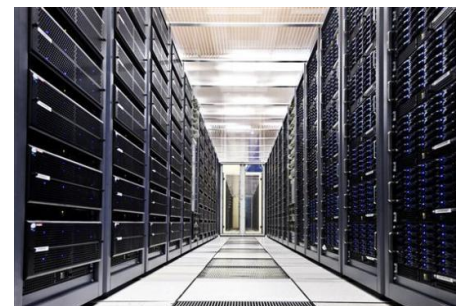
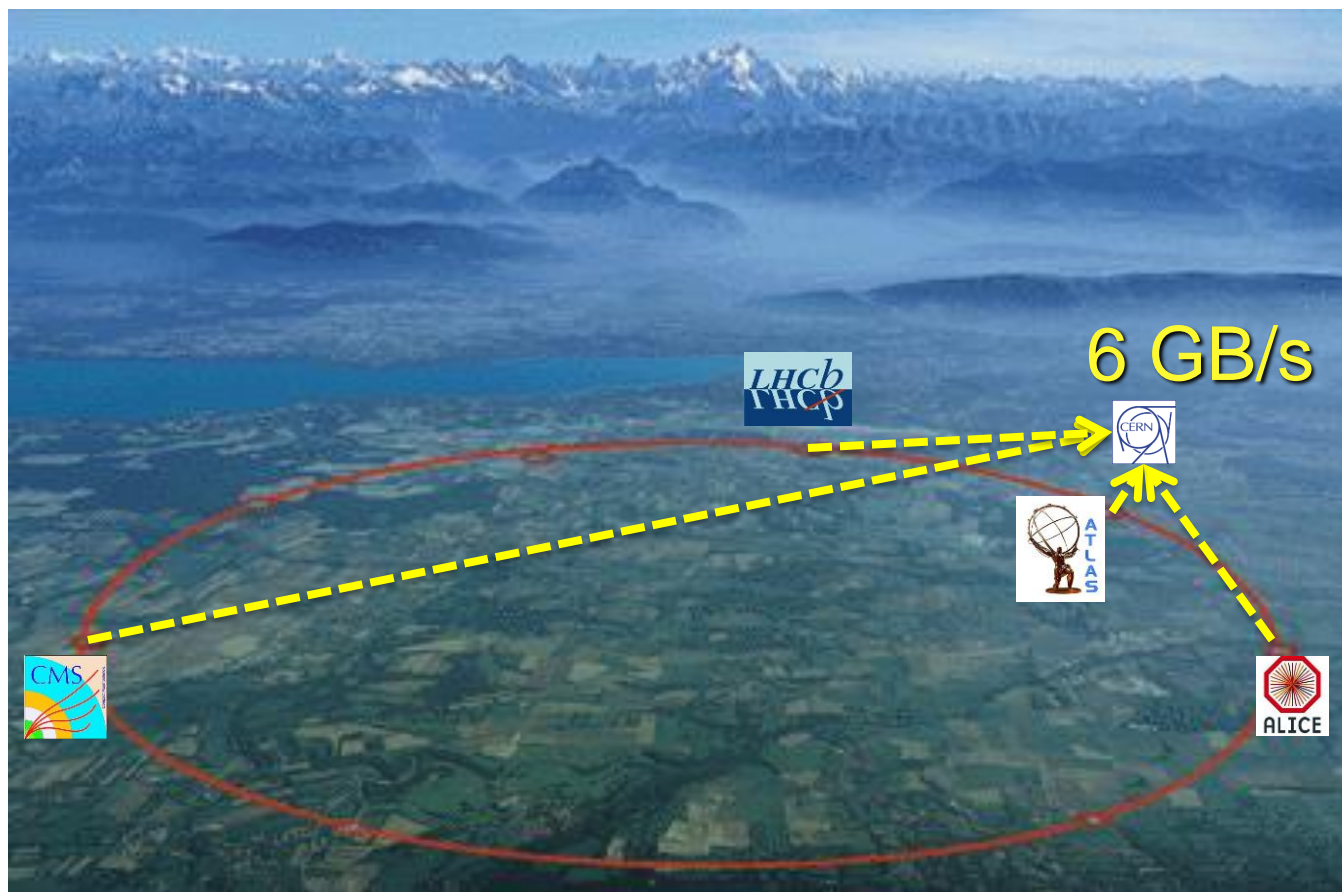

80,000 Disks
88,000 CPU Cores

18,000 1GB NICs
2,700 10GB NICs



The LHC Data Challenge

- Few places can store it
- Processing needs 5x CERN
- HEP community distributed
 - Local funding for computing
- Distributed solution...



- Models of Networked Analysis at Regional Centres



x 2 locations @ CERN



Resource Management - *circa* 1999

- Keep track of LHC project and CERN2
 - Computing power and Data Storage capacity
 - Researchers turnover ~2 years
- Resources of CERN and its experiments
 - Not hierarchical, or centrally controlled
 - A multiply connected web
 - Experts install locally, update independently
 - Community is distributed: remote access
- System to link it all together
- CERN is a model in miniature of the rest of world in a few years time



Solution: the Grid

- Use the Grid to unite computing resources of particle physics institutes around the world

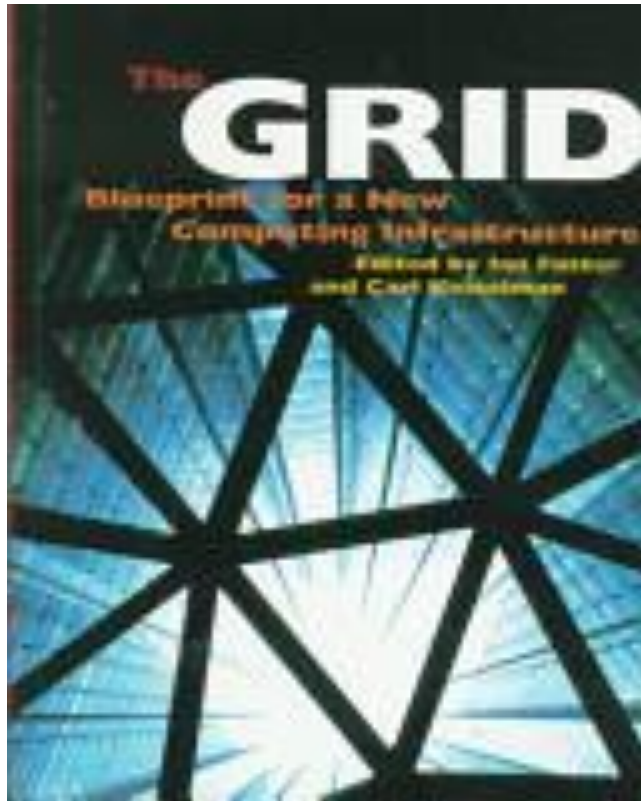

Worldwide LHC Computing Grid

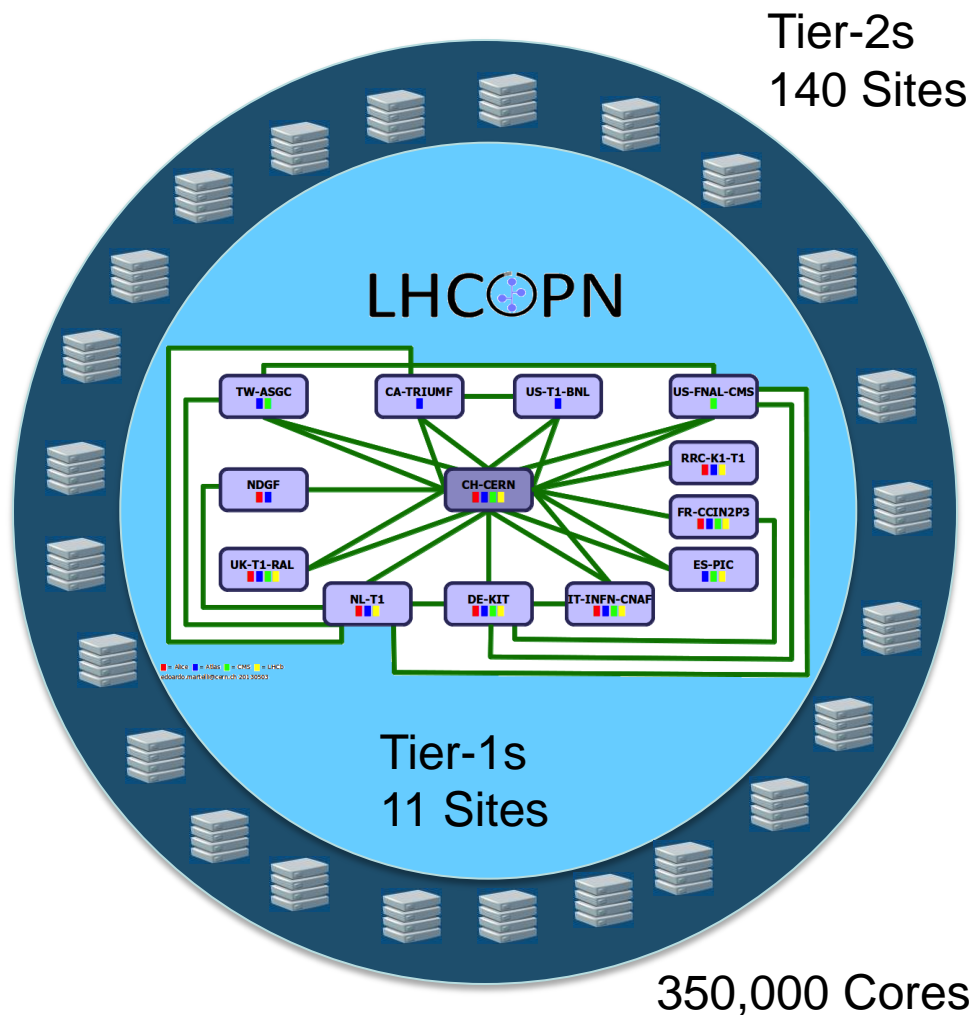
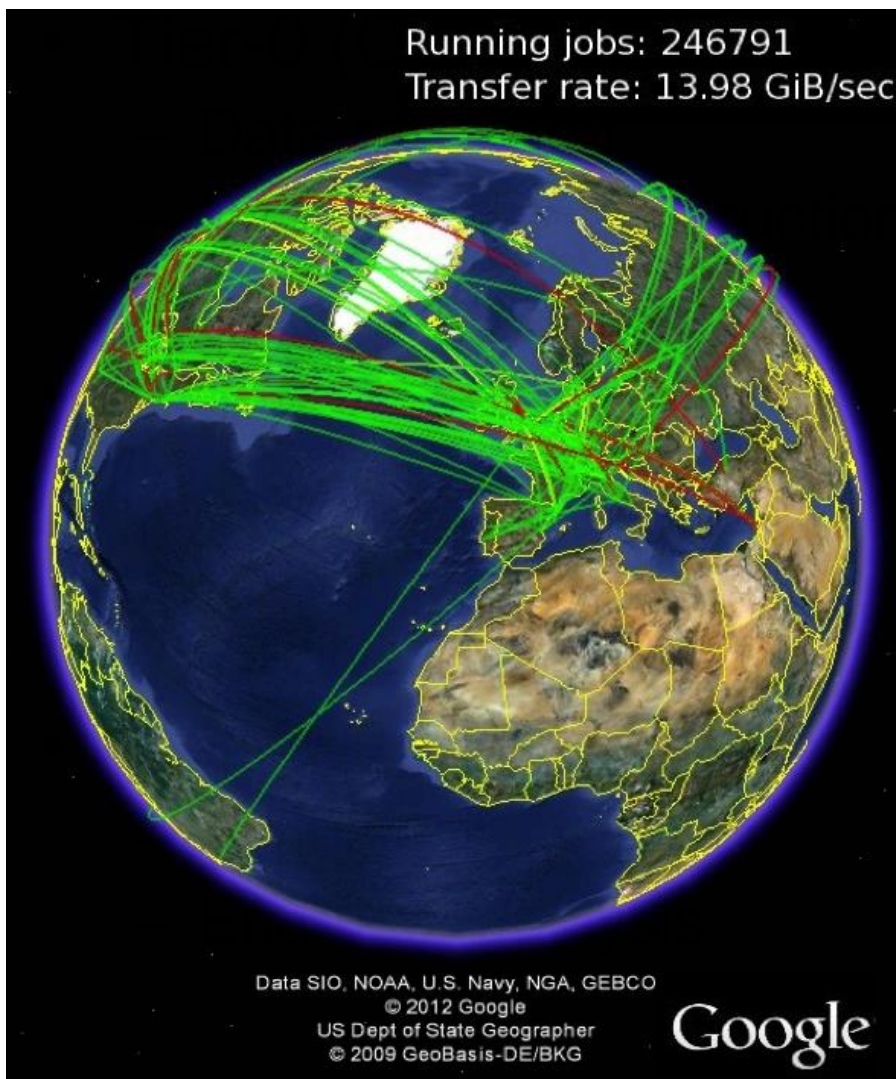

What is Grid Middleware?

- The glue that creates the illusion that a distributed infrastructure is a single resource
 - without enforcing uniformity
 - without central control
- Hide and manage heterogeneity
- Facilitate communication between users and providers

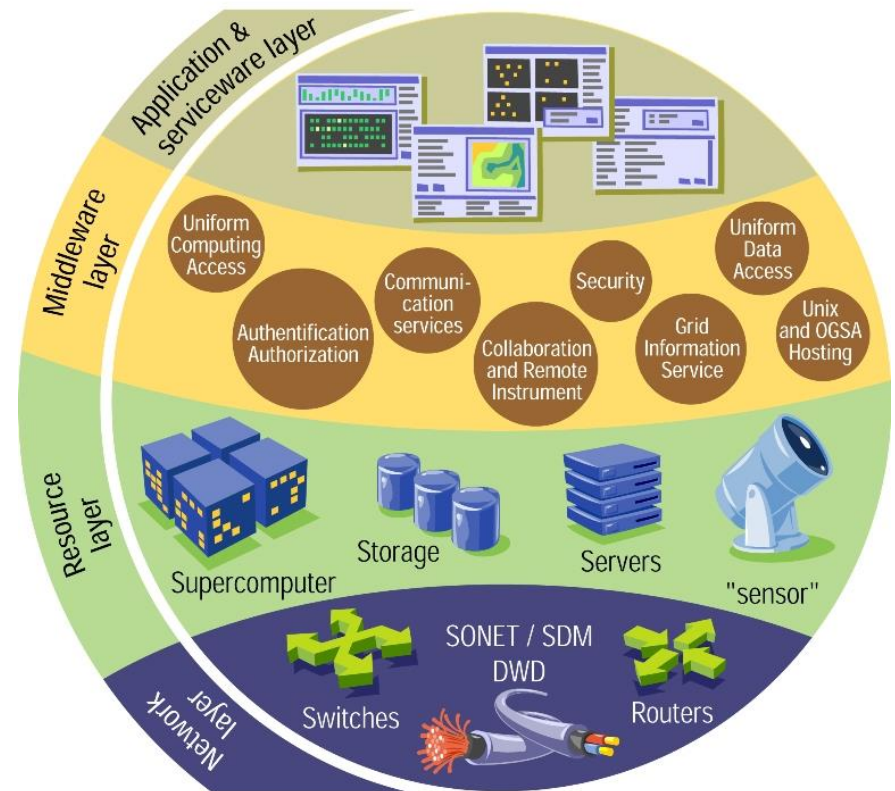

The Grid that Never Sleeps

1/1/2014 12:01:01 am

Running jobs: 223509
Transfer rate: 2.49 GiB/sec

Activity on 1 January 2014
Running Jobs: 223509
Transfer rate: ~2.5 GiB/s



US Dept of State Geographer
© 2013 Google
© 2009 GeoBasis-DE/BKG
Data SIO, NOAA, U.S. Navy, NGA, GEBCO

Google earth

56°02'55.29" N 39°34'04.37" E eye alt 27557.33 km

 dashboard

[Tour Guide](#)



Data Transferred to Tape

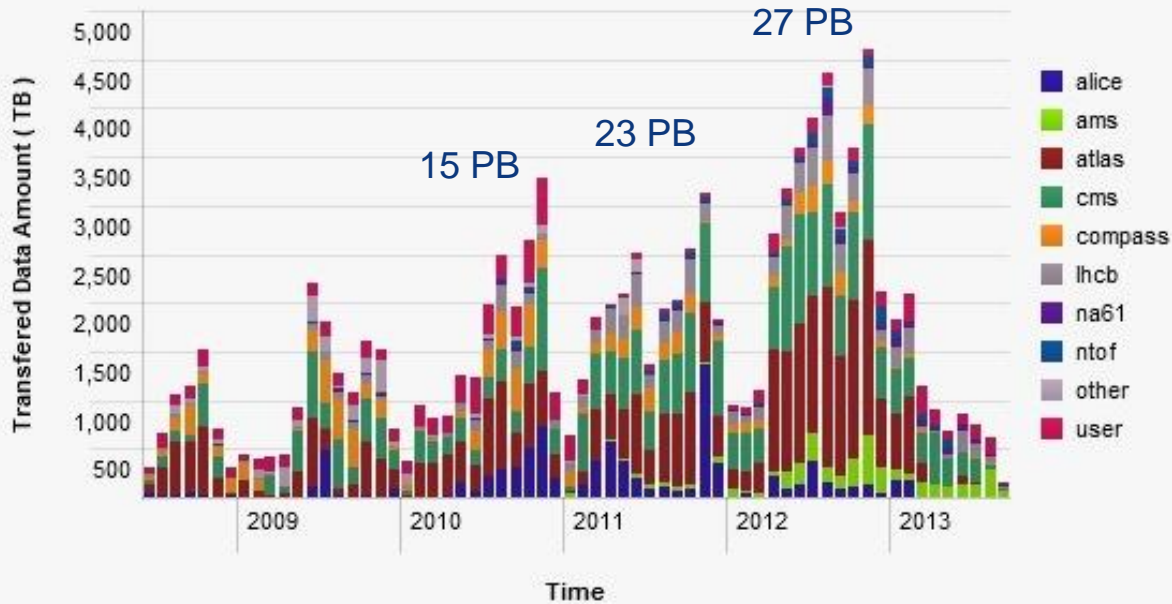

Expected 15TB/y

100 PB on tape !

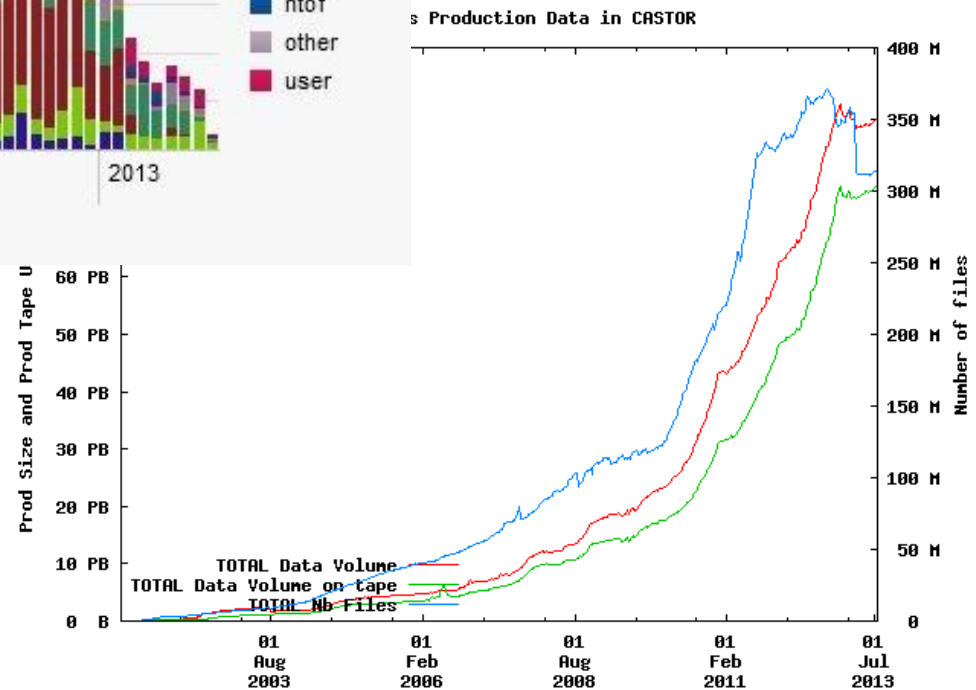

Generated Jul 23, 2013 CASTOR (c) CERN/IT



Data Reduction / Analysis

- Publication
- Reduced
- Reconstructed
- Raw

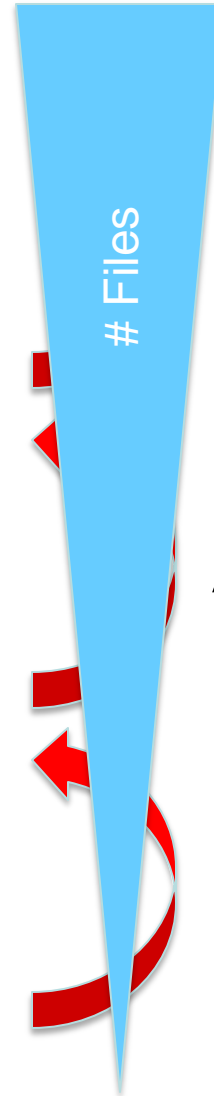
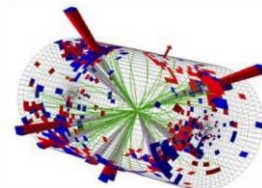
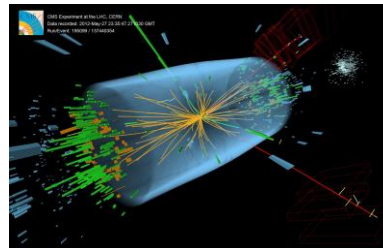
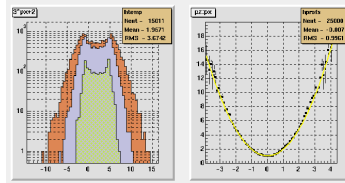
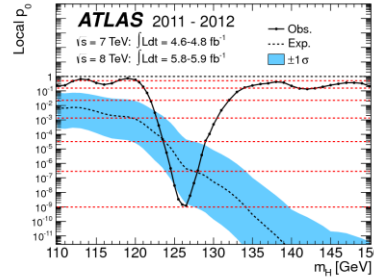
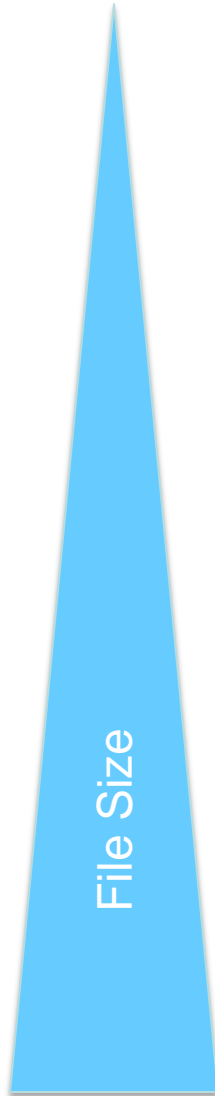

Researchers
T2s, T1s

Analysis Coordinators
T1s

Production Managers
T0, T1s

Data Inflation

- Static: Storing 100 PB was a good challenge 😊
- Dynamic: Analysing it means transformation, reduction, transport, replication, regeneration

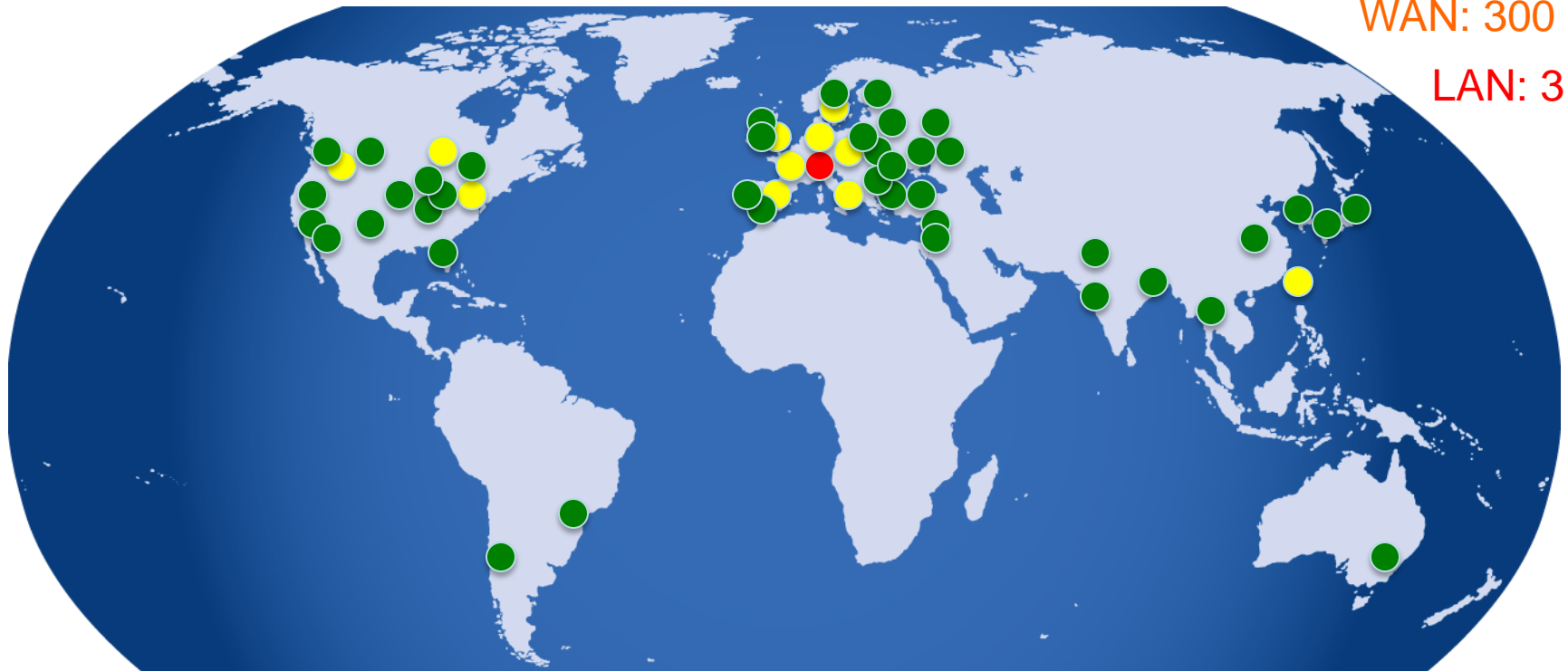

WAN: 300 PB

LAN: 3 EB

Managing a 100 PB Store

- Media Verification

- Hot / Cold Data
- Catching and correcting errors while you still can
- 10% of production drive capacity for 2.6 years

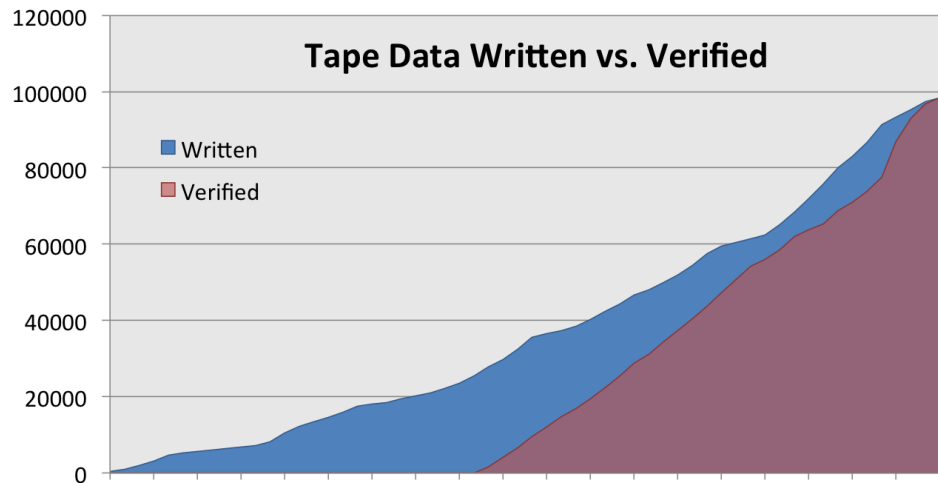

- (0.000065% data loss)

Managing a 100 PB Store

- Media Migration
 - Drive and Media obsolescence
 - 50% of current drive capacity for 2 years

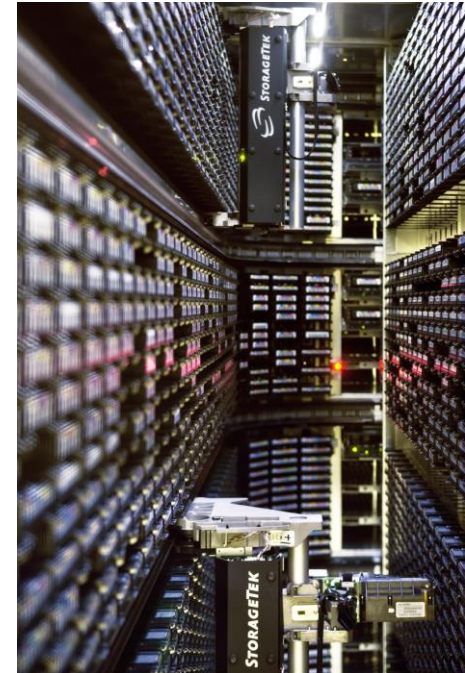

Shared Infrastructures

- >270 VOs from several scientific domains
 - Astronomy & Astrophysics
 - Civil Protection
 - Computational Chemistry
 - Comp. Fluid Dynamics
 - Computer Science/Tools
 - Condensed Matter Physics
 - Earth Sciences
 - Fusion
 - High Energy Physics
 - Life Sciences
 -

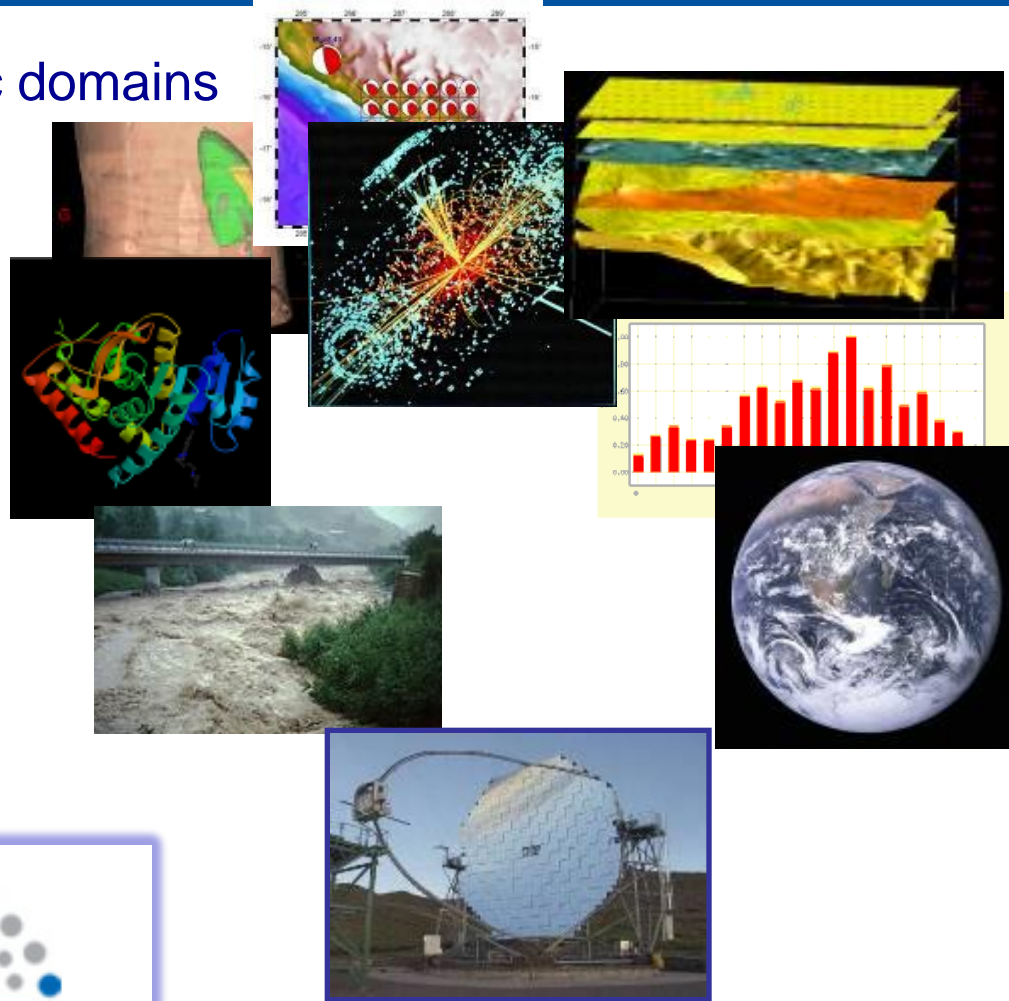

LHC Data Outlook

2009 2010 2011 2011 2013 2014 2015 2016 2017 2018 2019 2020 2021 2022 2023 2024 ... 2030?

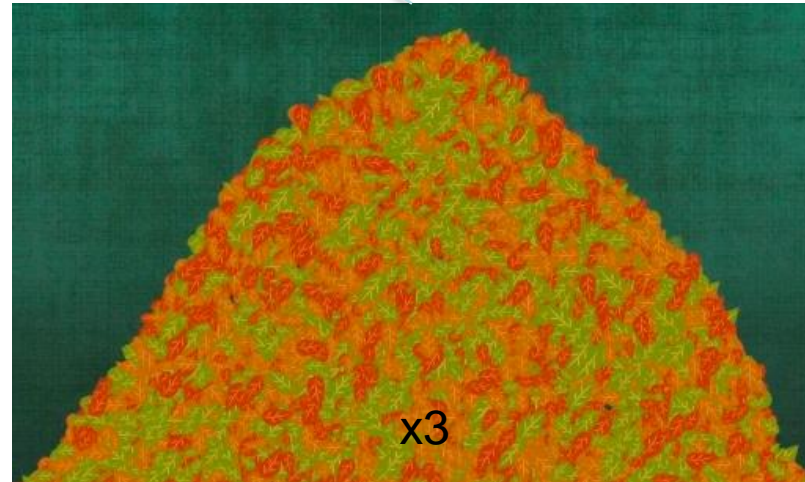
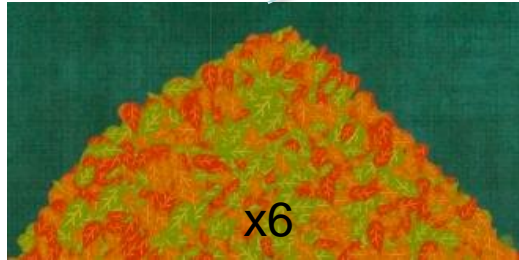
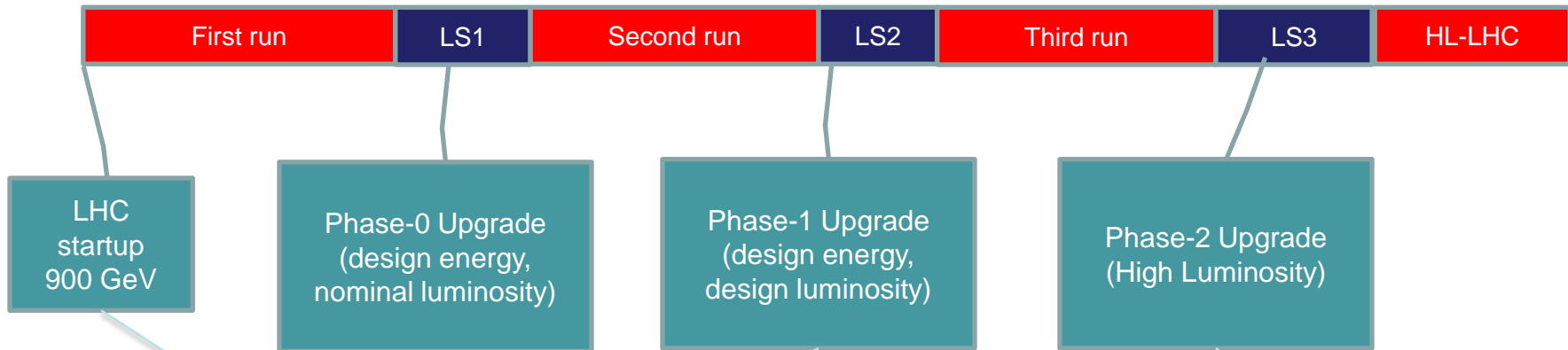

Computing Model Evolution

- Flattening the tiered structure
 - Strict hierarchy of connections becomes more of a mesh
- Network: a resource to schedule
 - Sending data directly to worker node over wide area network
- Pilots jobs
 - Building up an enormous batch queue
 - LHC experiments use the same read-only environment centrally distributed to nearly half a million processor cores
- **AAA: any data, any time, any where 😊**

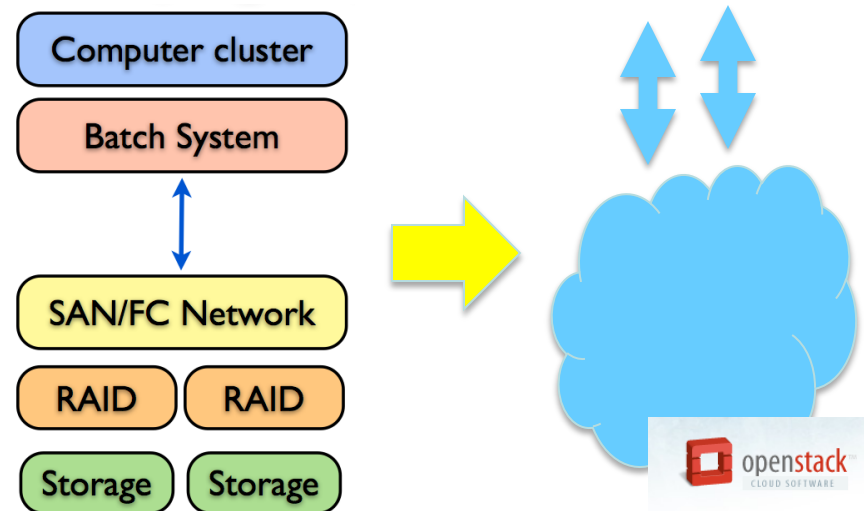
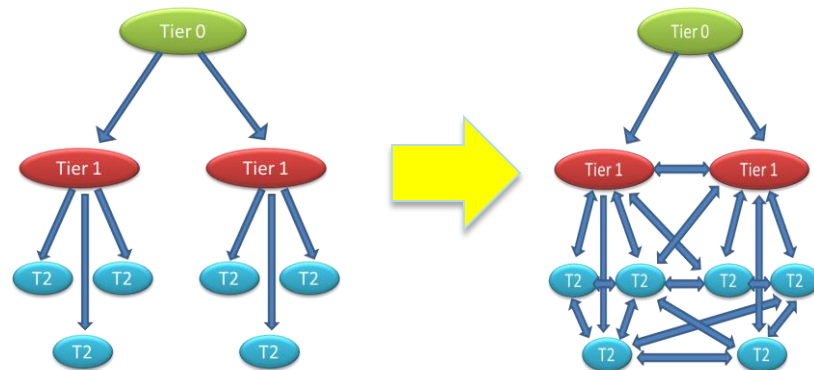

A New Computer Centre

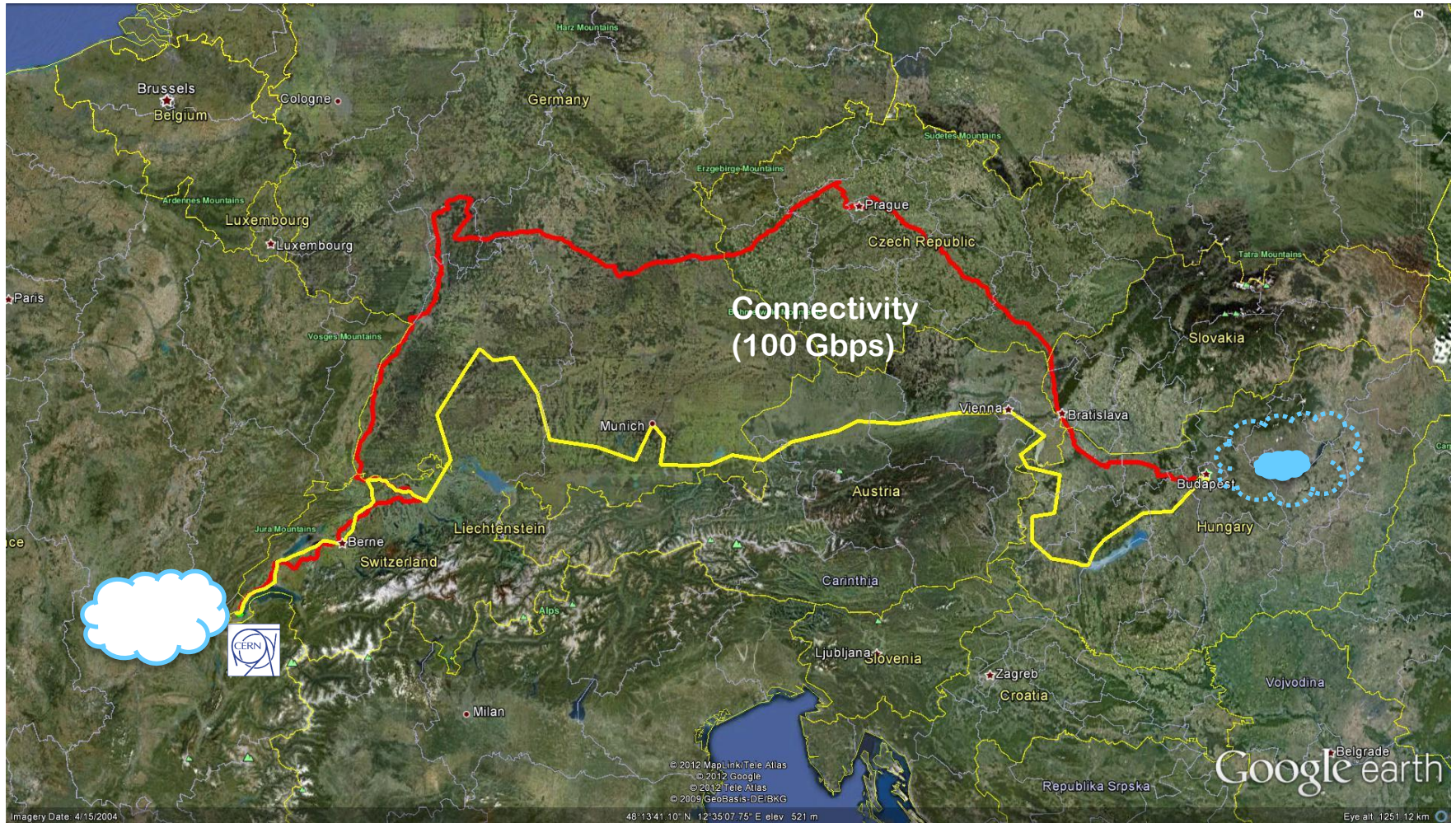

2015: 15k servers, 300k VMs



Computing

- Technical

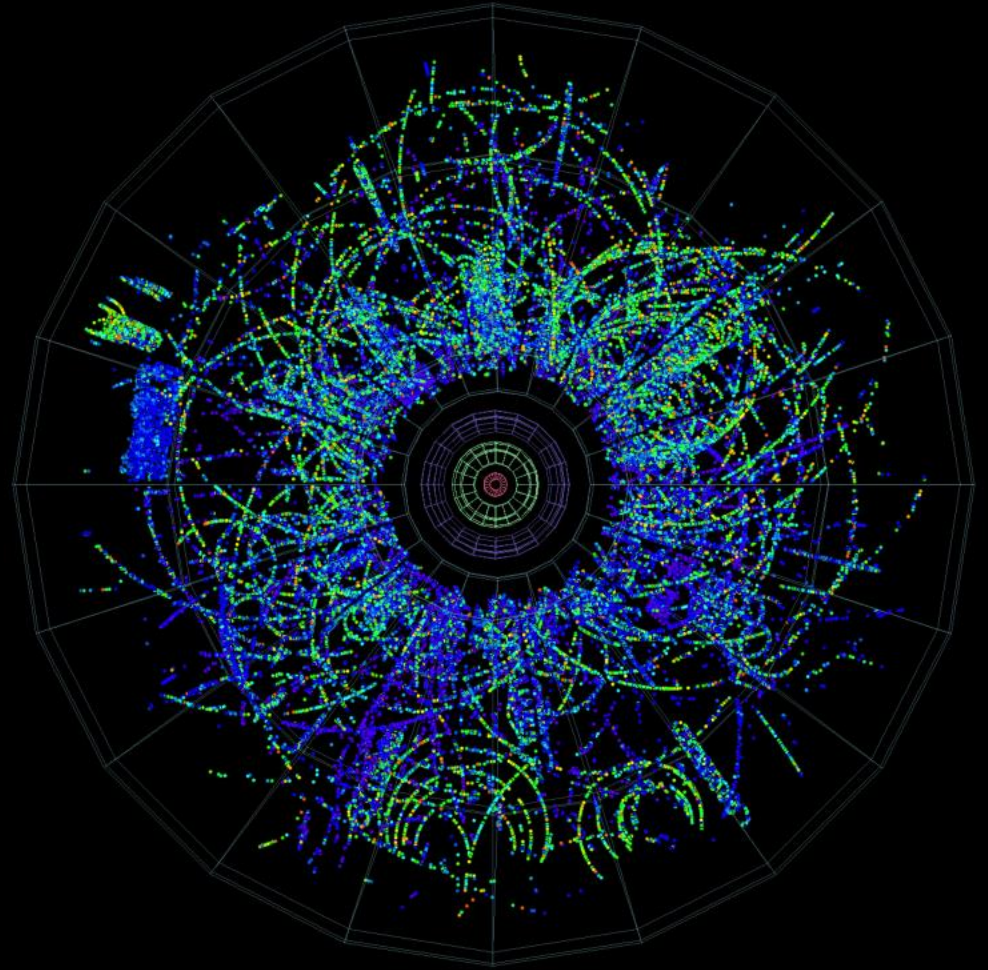

Design

- Magnet Design

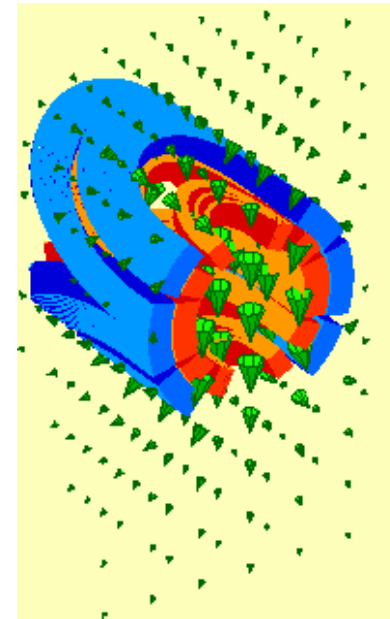
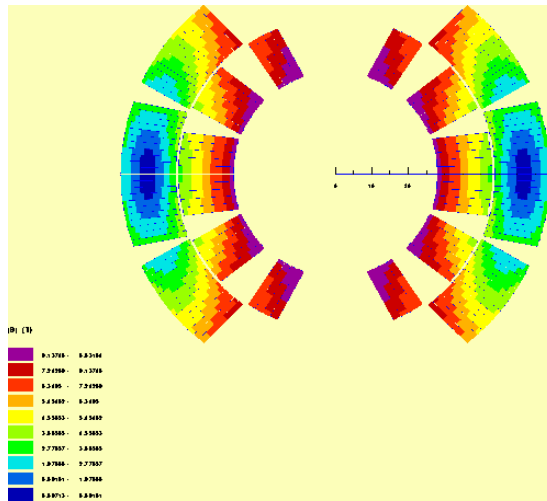

- Volunteer Computing

- LHC@home
- SixTrack



- Simulates particles accelerating around the 27 km LHC to find their orbit stability

Operations



Computing

- Administrative
- Software

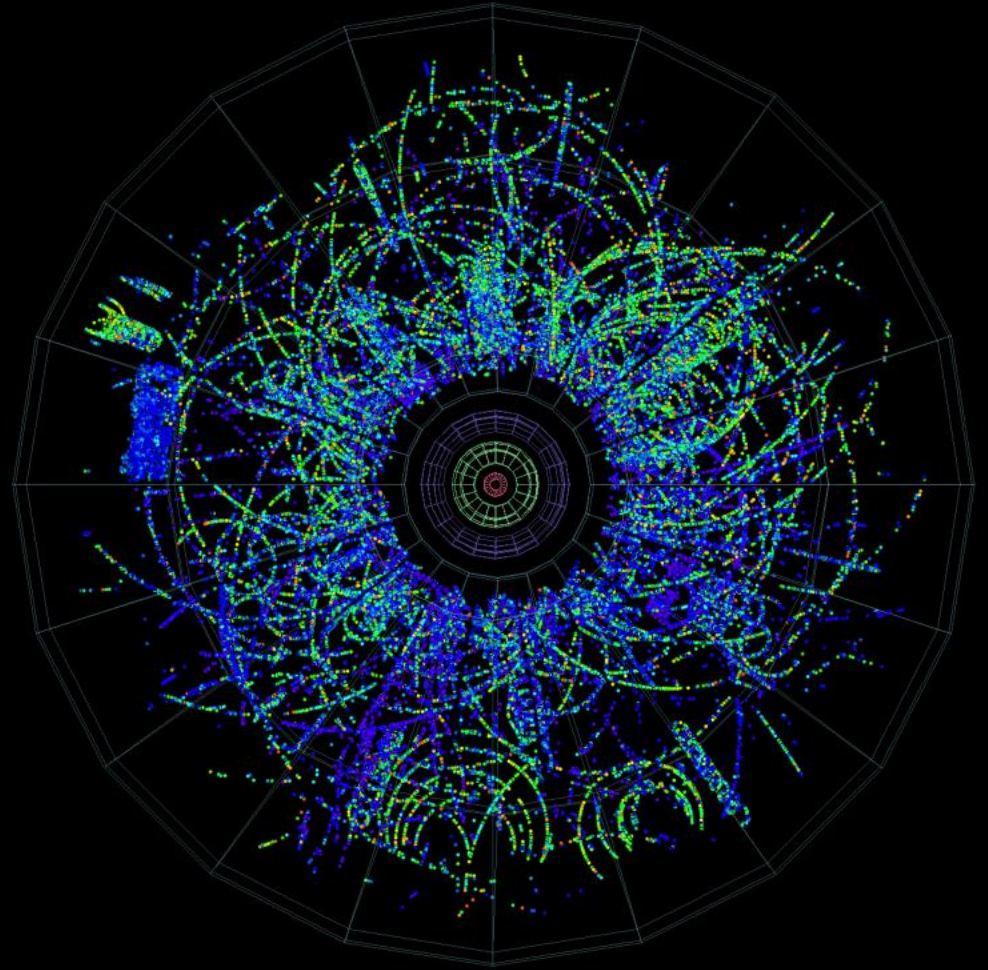

Administrative Information Services

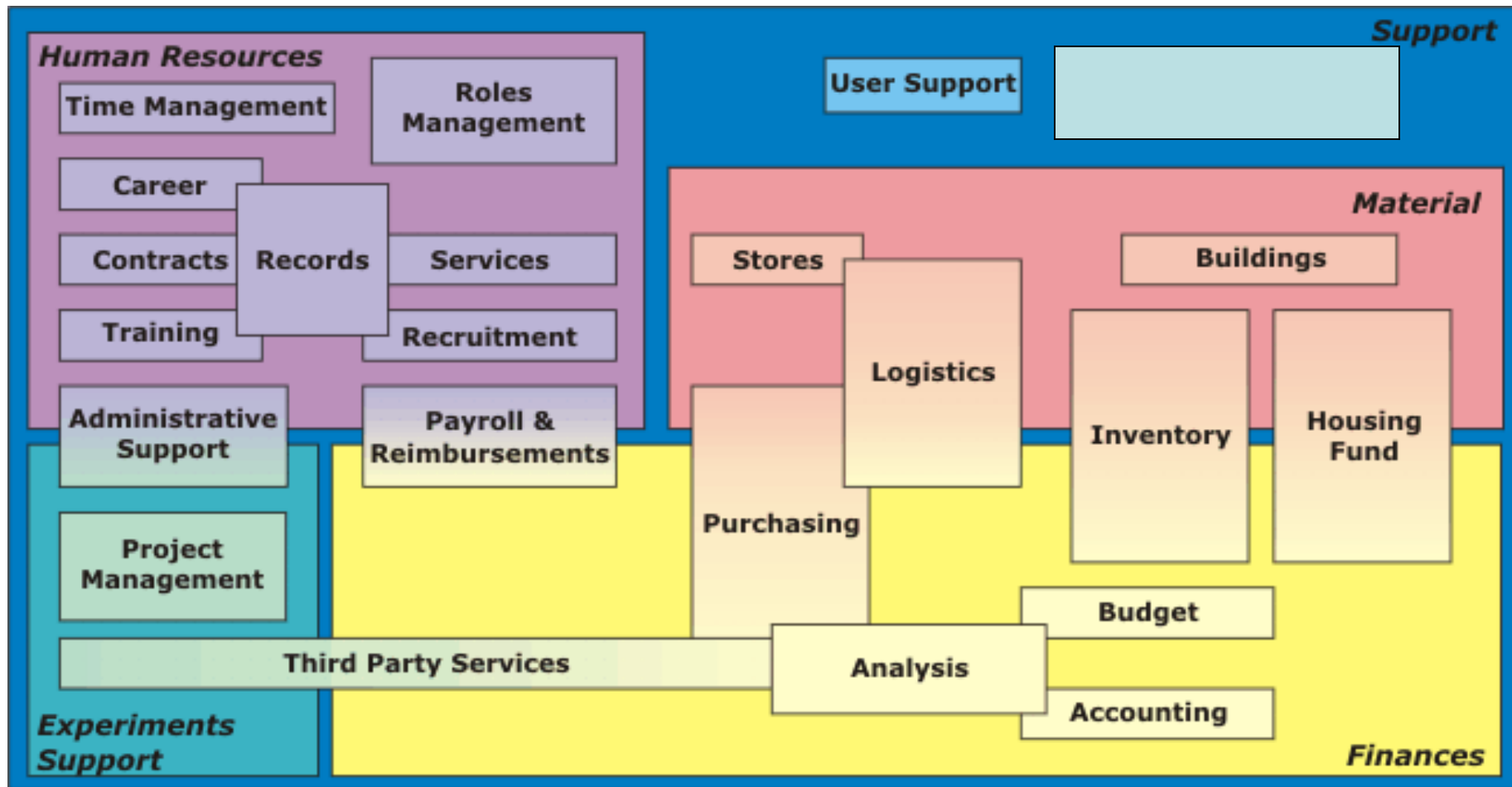

Administrative Information Services

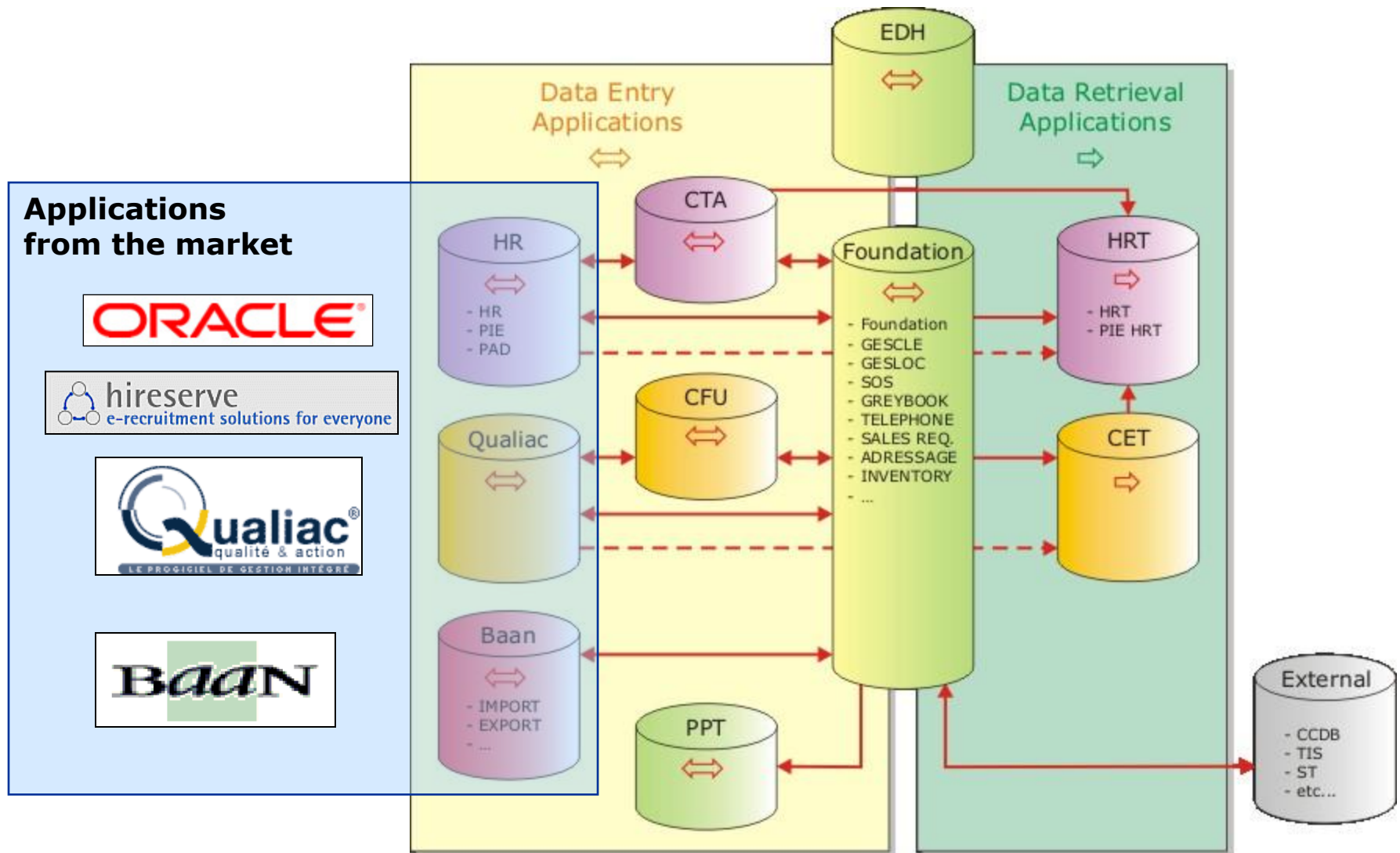

Software for Open Science

- Invenio: 514k; Indico: 377k
Code Analysis

Code Analysis

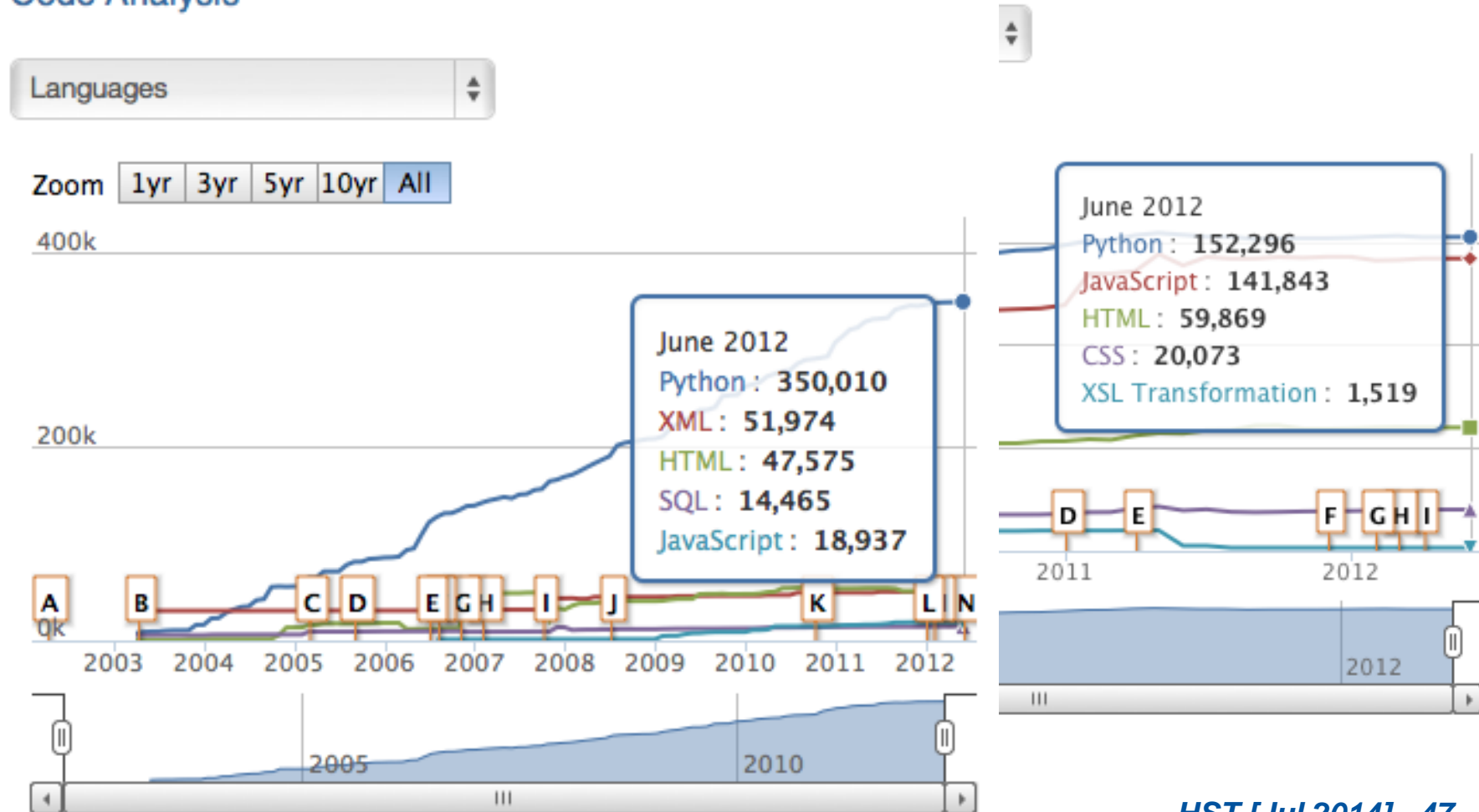

Computing

- Collaborative

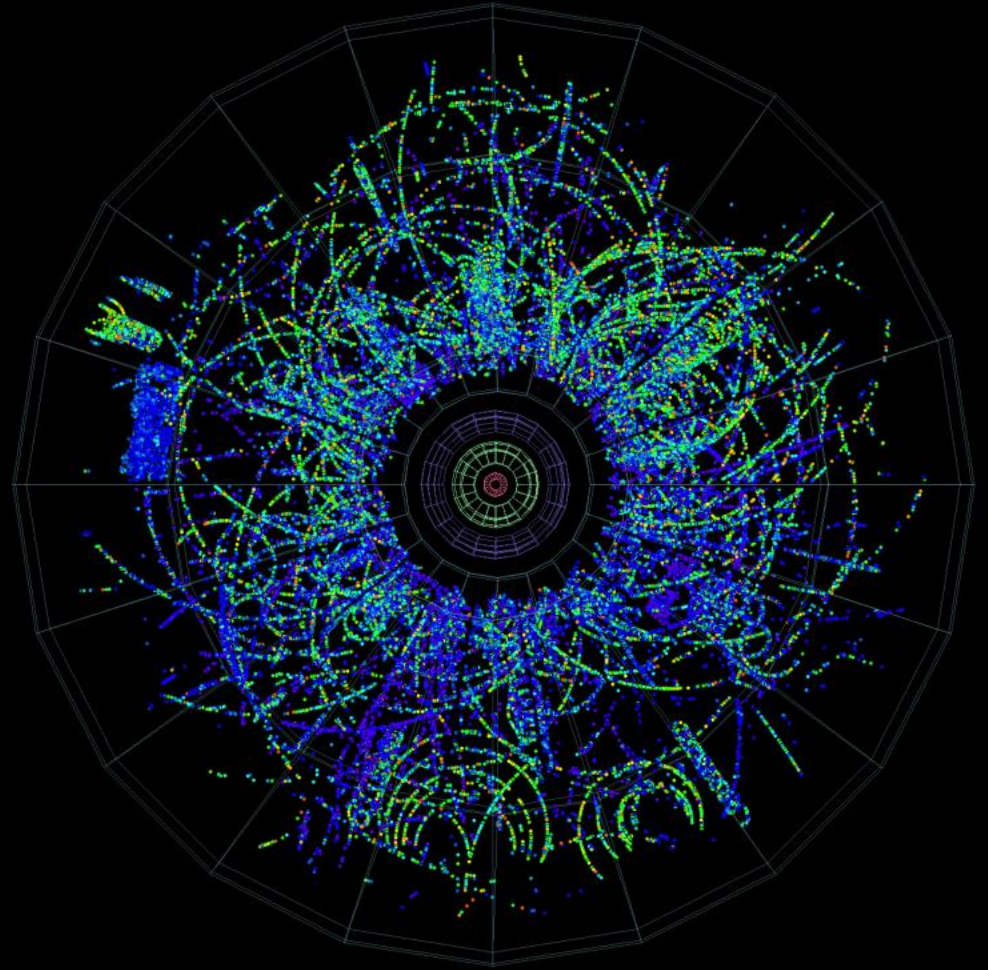

Videoconference

- 250 meeting rooms of all sizes on site
 - 90 equipped for video conference
 - Legacy + VidyoPanorama
 - 13 equipped for VC + Webcast
- 500 legacy endpoints worldwide
 - Non centrally managed

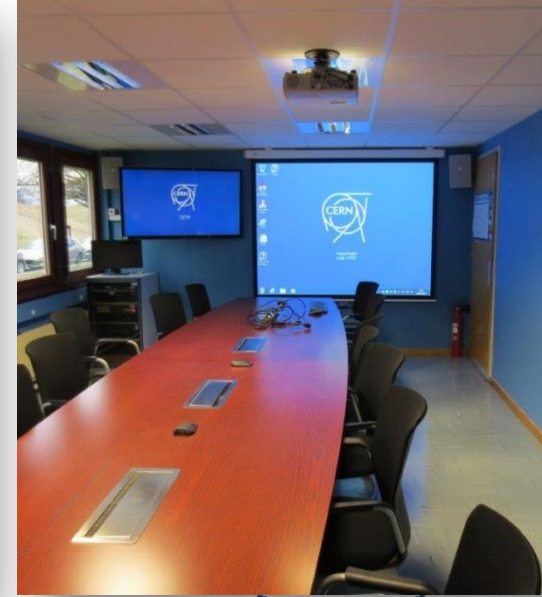
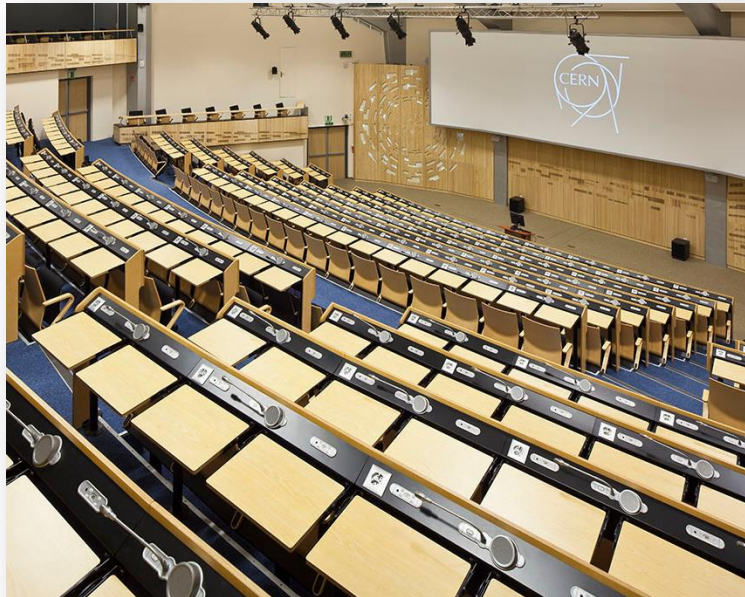

CERN Vidyo Worldwide Service Topology



- 3200 meetings/month
- 852 simultaneous connections
- 252 in one meeting
- 50M minutes last year / 40k downloads

Recruitment

- Asynchronous video screening

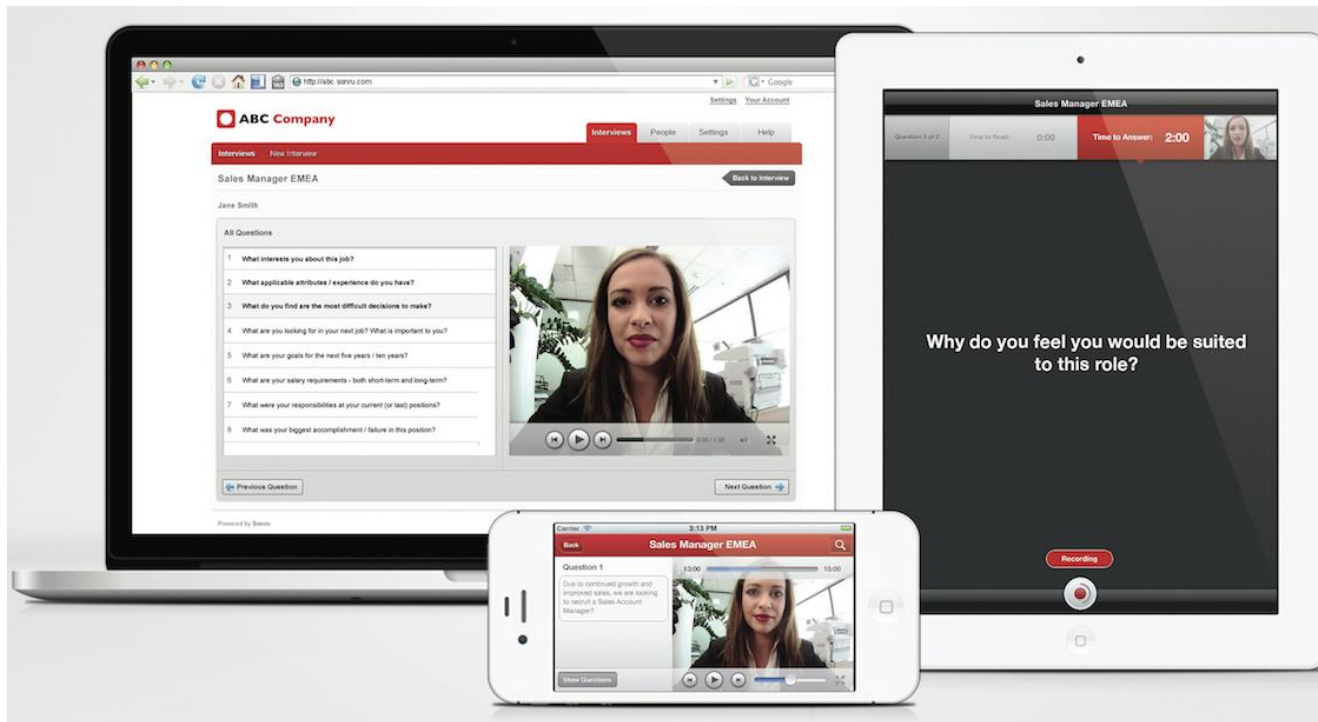

- Cost savings in bringing people to interview
- Multi-lingual – recruit from over 20 countries

CERN's social media

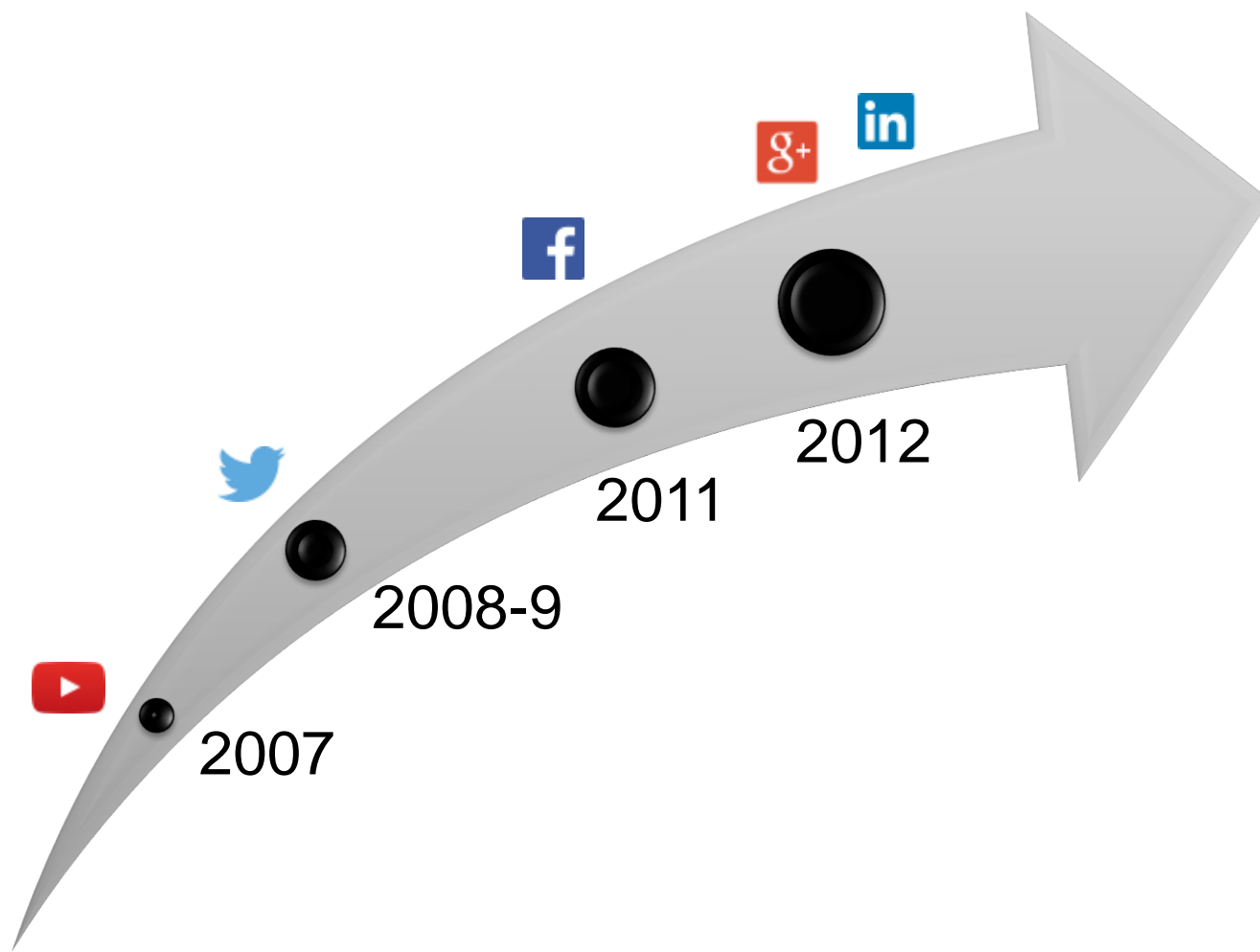

	975K
	309K
	92K
	40K
	20K
	12K

Impact



Courtesy of Twiplomacy, November 2013

Behind Open Science

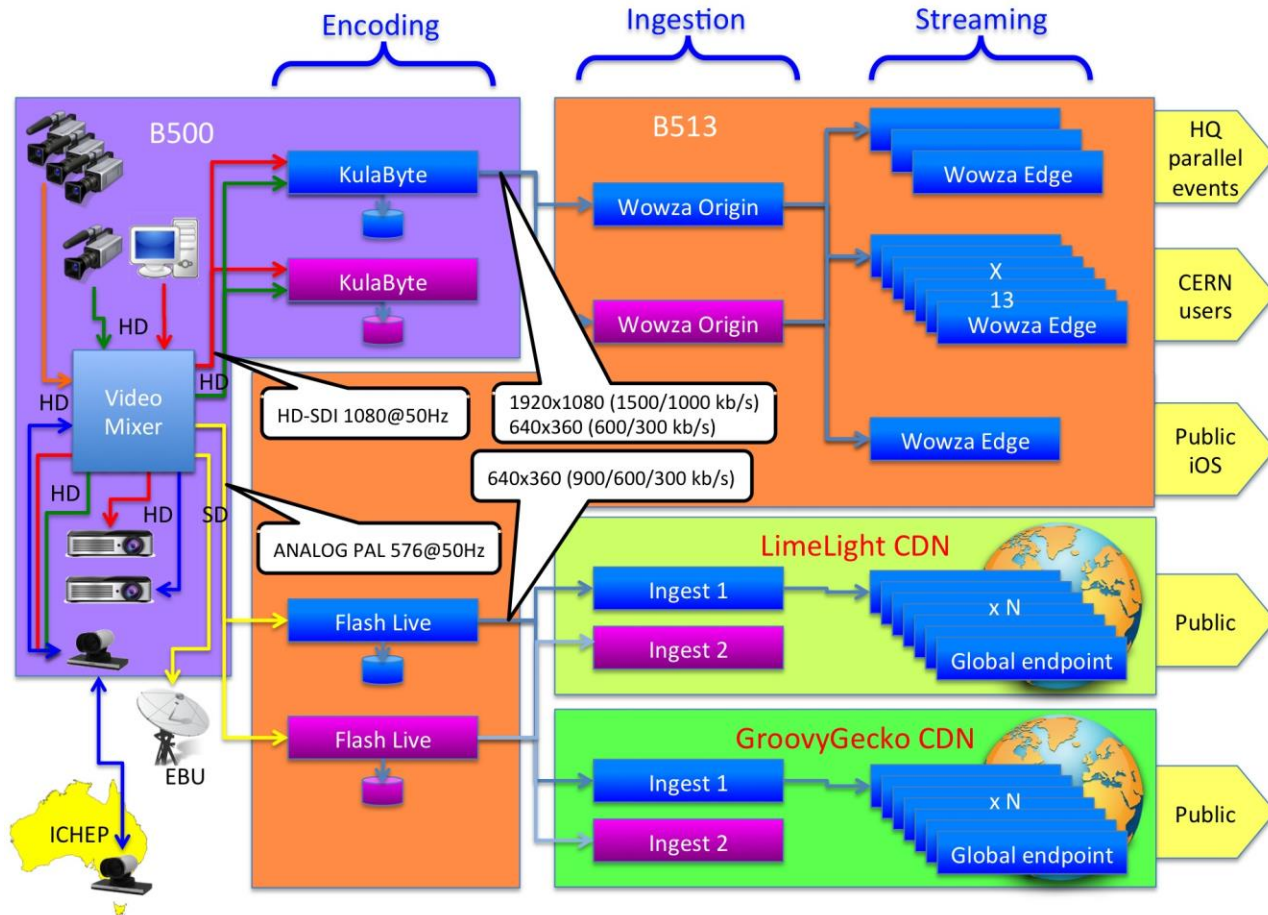

...Biggest Scientific Event ever
 WebCast ~Million
 TV ~Billion





www.cern.ch

Links (I)

- Contact:
 - Tim.Smith@cern.ch
- More information:
 - IT Department: <http://information-technology.web.cern.ch>
 - The LHC Grid: <http://wlcg.web.cern.ch>
 - Google Street view in CC:
 - https://www.google.ch/maps/@46.232624,6.045747,3a,75y,162.48h,90t/data=!3m5!1e1!3m3!1sBU7JKhoaY_H9JVPFHcH8JA!2e0!3e5?hl=en
 - <http://lego-scavenger-hunt.web.cern.ch>
 - IT Archives: <https://it-archives.web.cern.ch>



Links (II)

- Social Media at CERN
 - <http://twitter.com/CERN>
 - http://twitter.com/CERN_FR
 - <http://facebook.com/cern>
 - <http://google.com/+CERN>
 - <http://youtube.com/CERN>
 - <http://linkedin.com/company/cern>

