

G4Vis: Status, New Features and Issues

Geant4 Collaboration
Workshop

Lisboa

2006

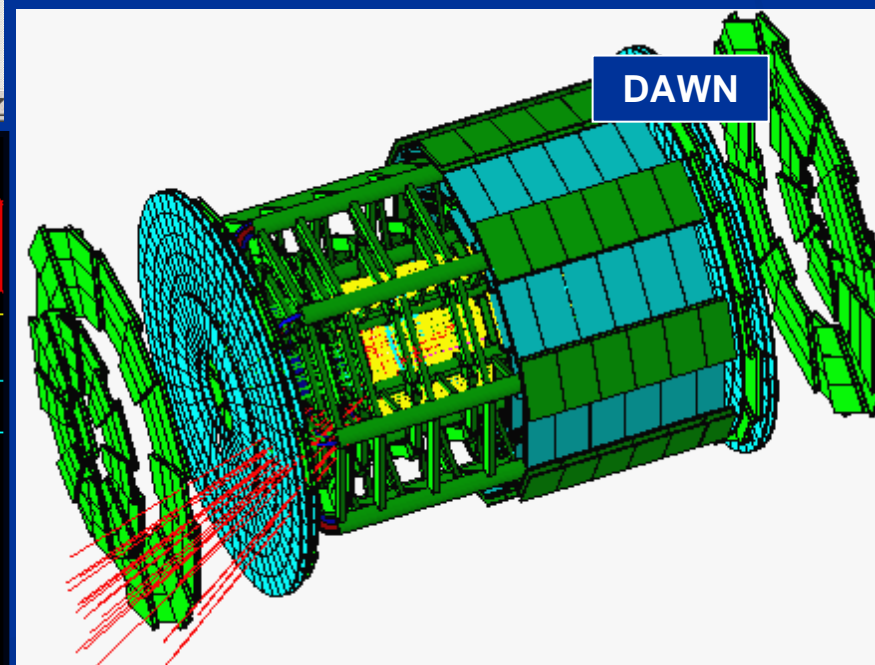
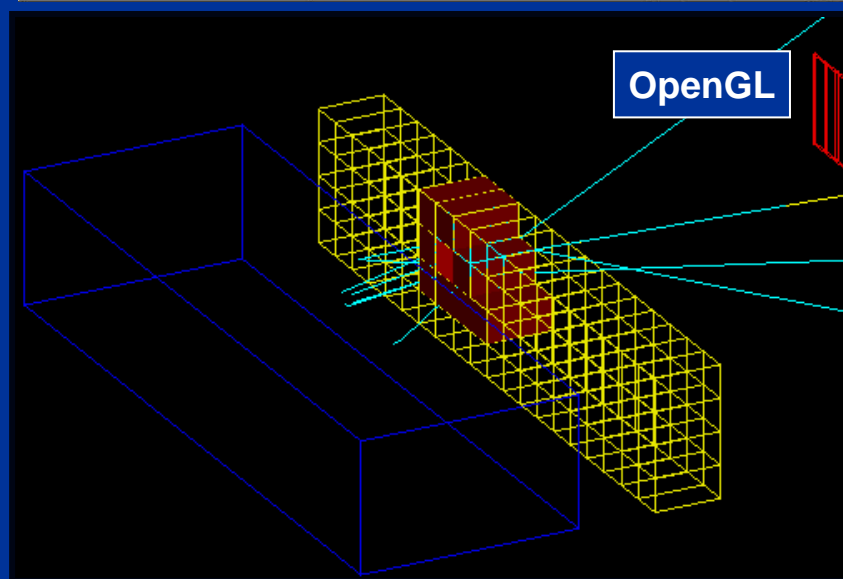
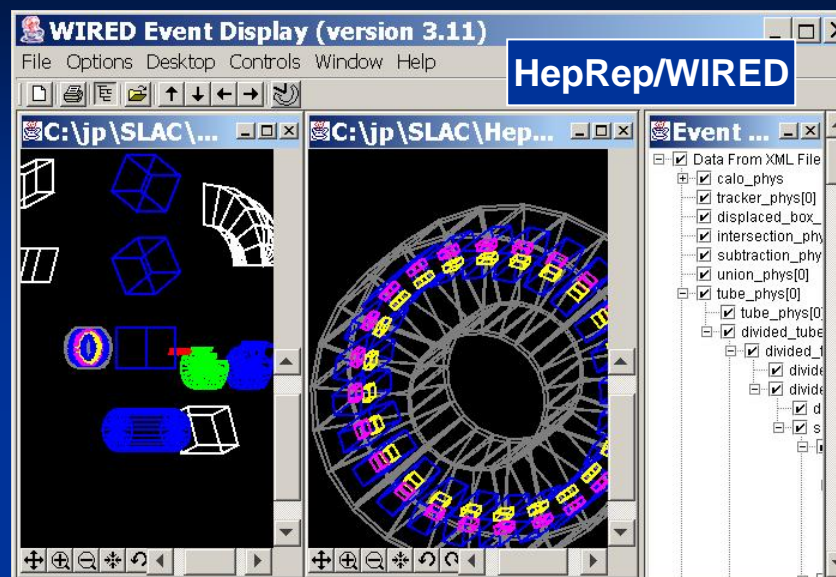

Sorry, Vis Status Talks always need two pages of Cover Graphics

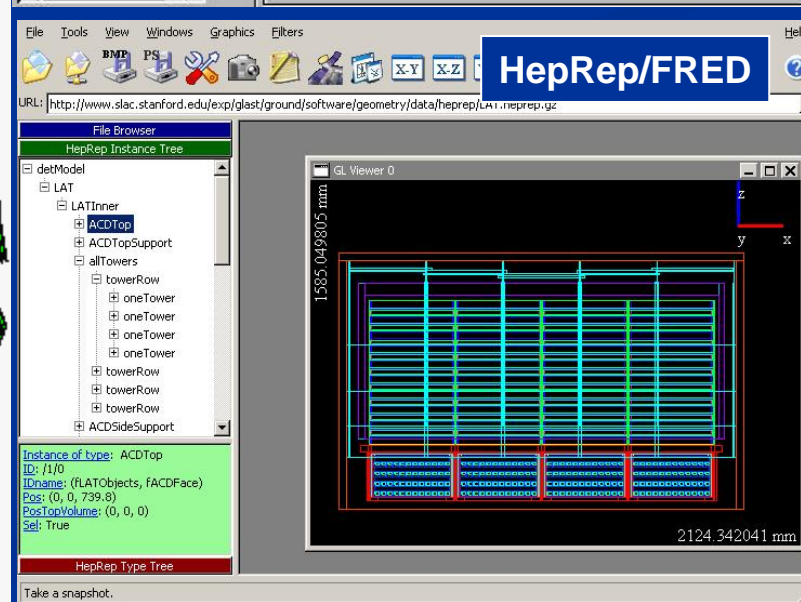
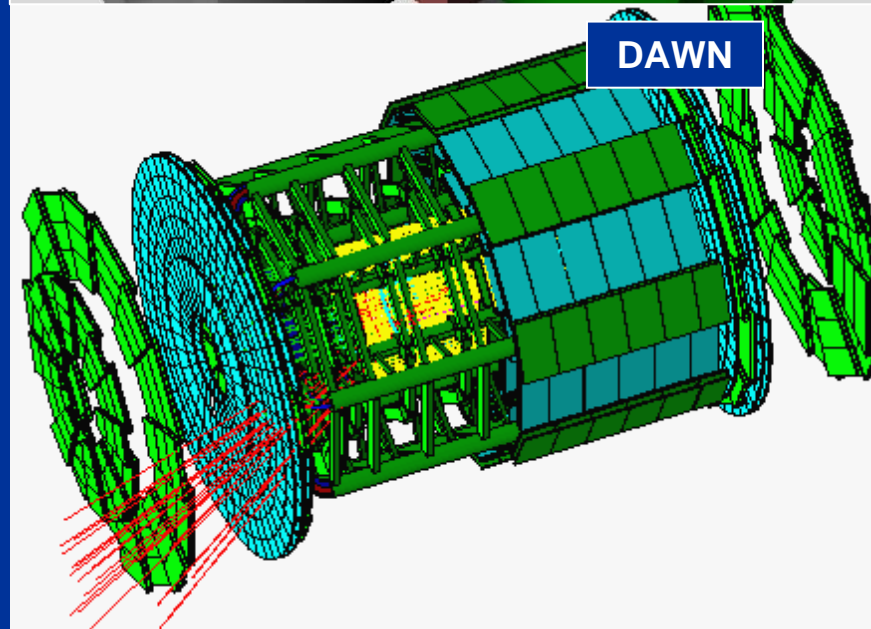
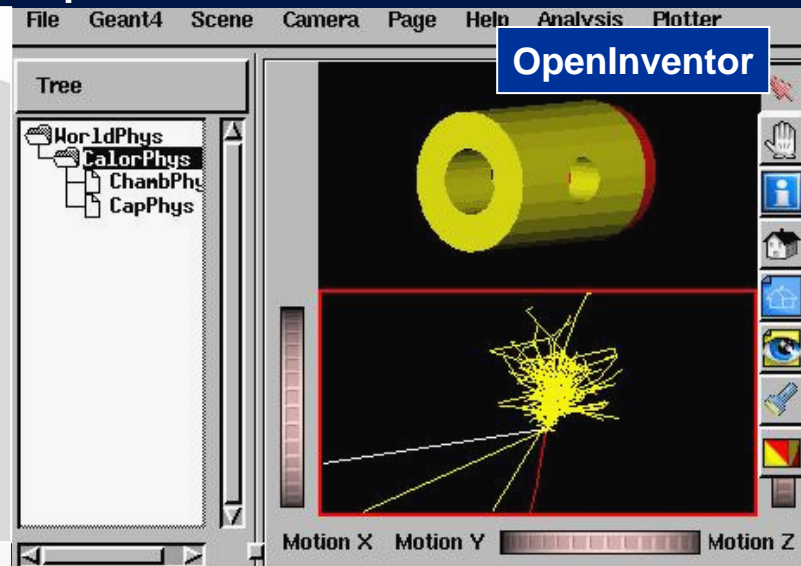
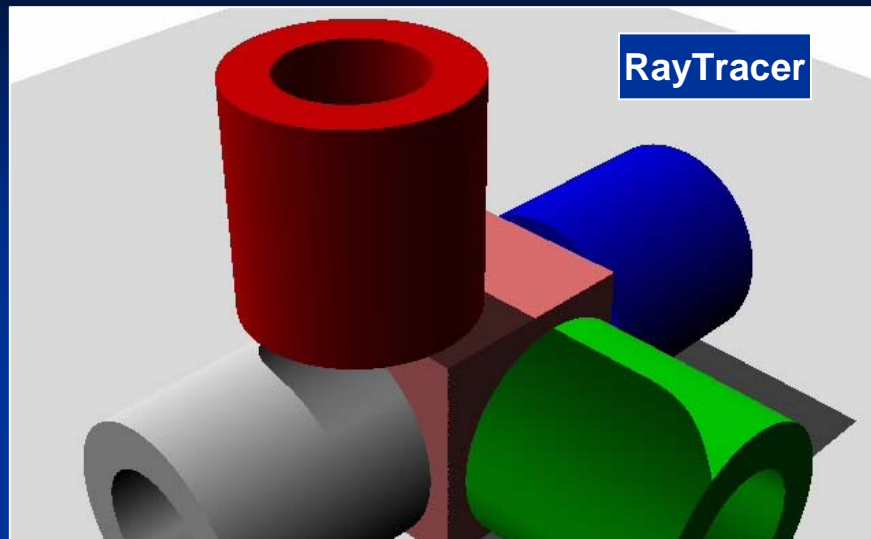

Contents

- Status -
Joseph Perl
- New Features: Trajectory Modeling and Filtering -
Jane Tinslay
- New Features: Movies -
John Allison
- Issue: Boolean Processor, Generic Sections and Cutaways -
John Allison

Status: Seven Visualization Drivers

OpenGL

- /vis/open OGLIX
- Features
 - Control directly from Geant4
 - Uses GL libraries that are already included on most Linux and Windows systems
 - Rendered, photorealistic image with some interactive features
 - zoom, rotate, translate
 - Fast response (can usually exploit full potential of graphics hardware)
 - Limited printing ability (pixel graphics, not vector graphics)
- Supported by John Allison with Guy Barrand

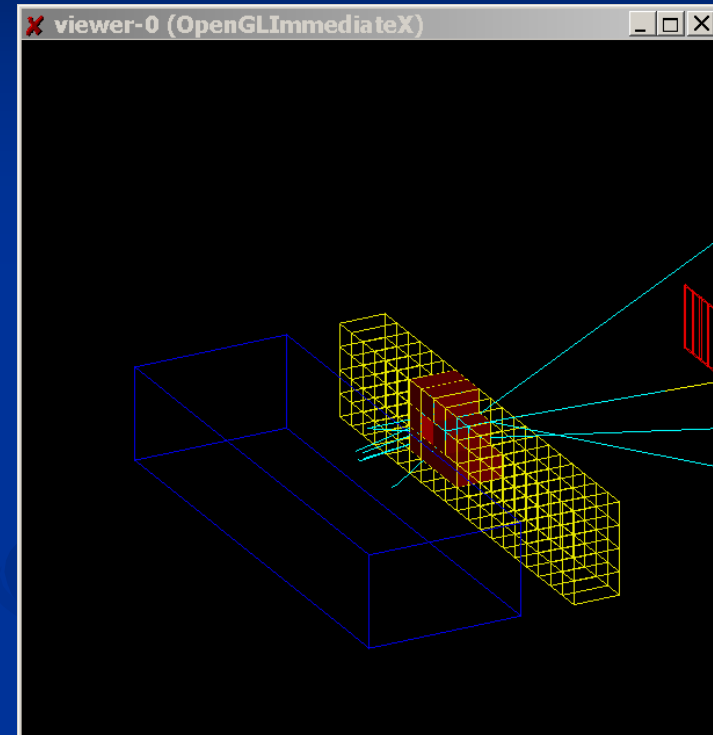

OpenGL with Motif Control

- If you don't have Motif, all control is done from Geant4 commands:
 - `/vis/open OGLIX` or `OGLSWin32`
 - `/vis/viewer/set/viewpointThetaPhi 70 20`
 - `/vis/viewer/zoom 2`
 - etc.
- But if you have Motif libraries, you can control Geant4 from Motif widgets:
 - `/vis/open OGLIXm`

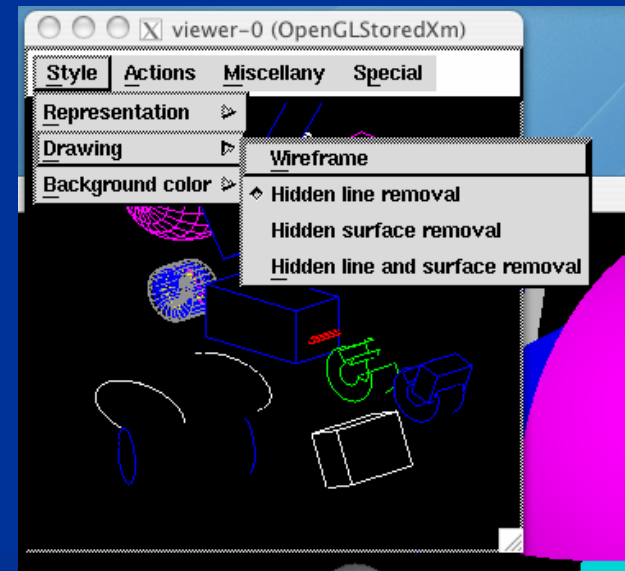
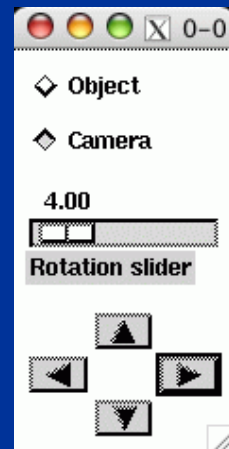

Hidden Line Removal

- OpenGL supports hidden line removal.
- You can control whether this removal is done and whether trajectories and hits are affected by this feature.
- By default, hidden line removal is disabled
- To turn on hidden line removal
 - `/vis/viewer/set/hiddenEdge 1`
- This hides edges of geometry, but lets trajectories through.
- To hide trajectories and hits as well
 - `/vis/viewer/set/hiddenMarker 1`

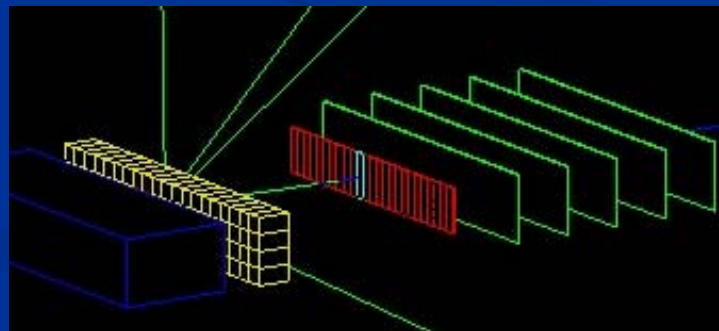
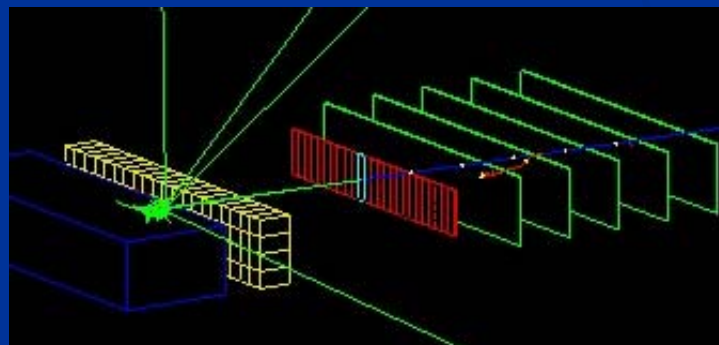
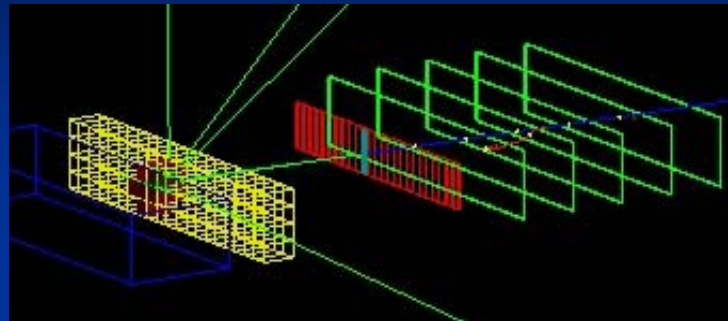

OpenInventor

- /vis/open OIX or /vis/open IOWin32

- Features
 - Control from the OpenInventor GUI
 - Requires addition of OpenInventor libraries (freely available for most Linux systems and Windows).
 - Rendered, photorealistic image
 - Many interactive features
 - zoom, rotate, translate
 - click to “see inside” opaque volumes
 - Fast response (can usually exploit full potential of graphics hardware)
 - Expanded printing ability (vector and pixel graphics)

- Supported by Guy Barrand

OpenInventor: Start from Geant4

- With OpenInventor, start from Geant4, but then some control from OpenInventor GUI

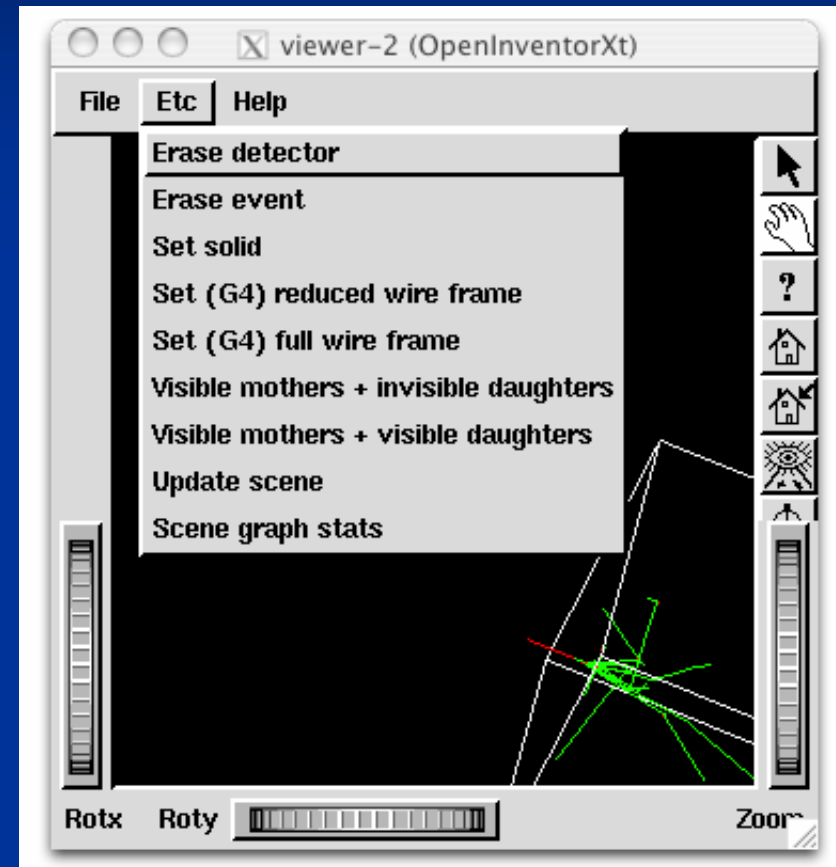
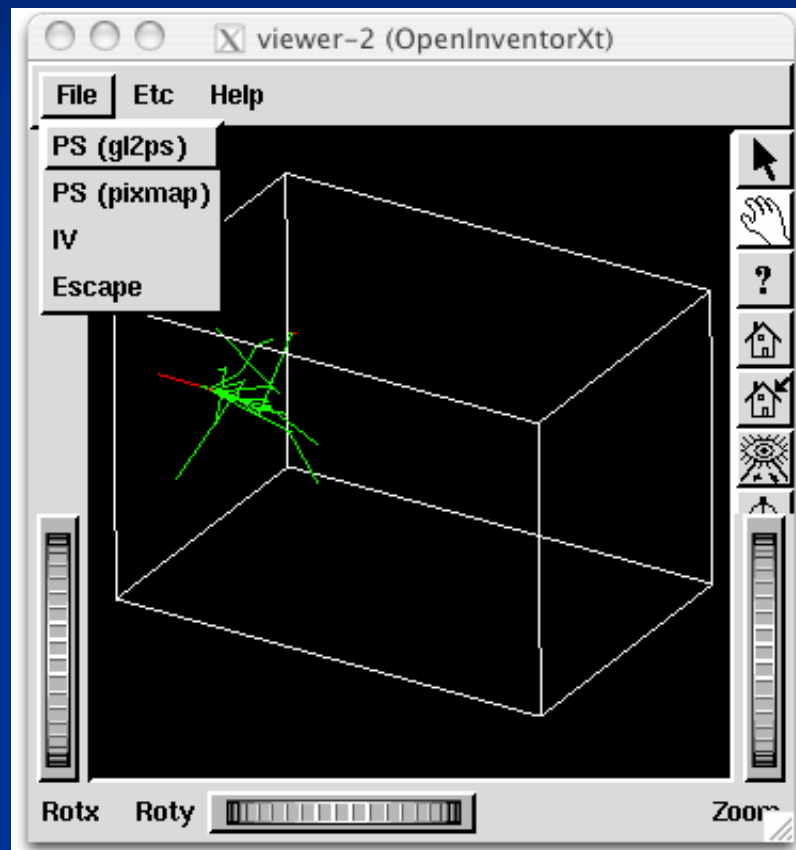

OpenInventor: More GUI Control

- You can also choose to control the Geant4 run from OpenInventor.

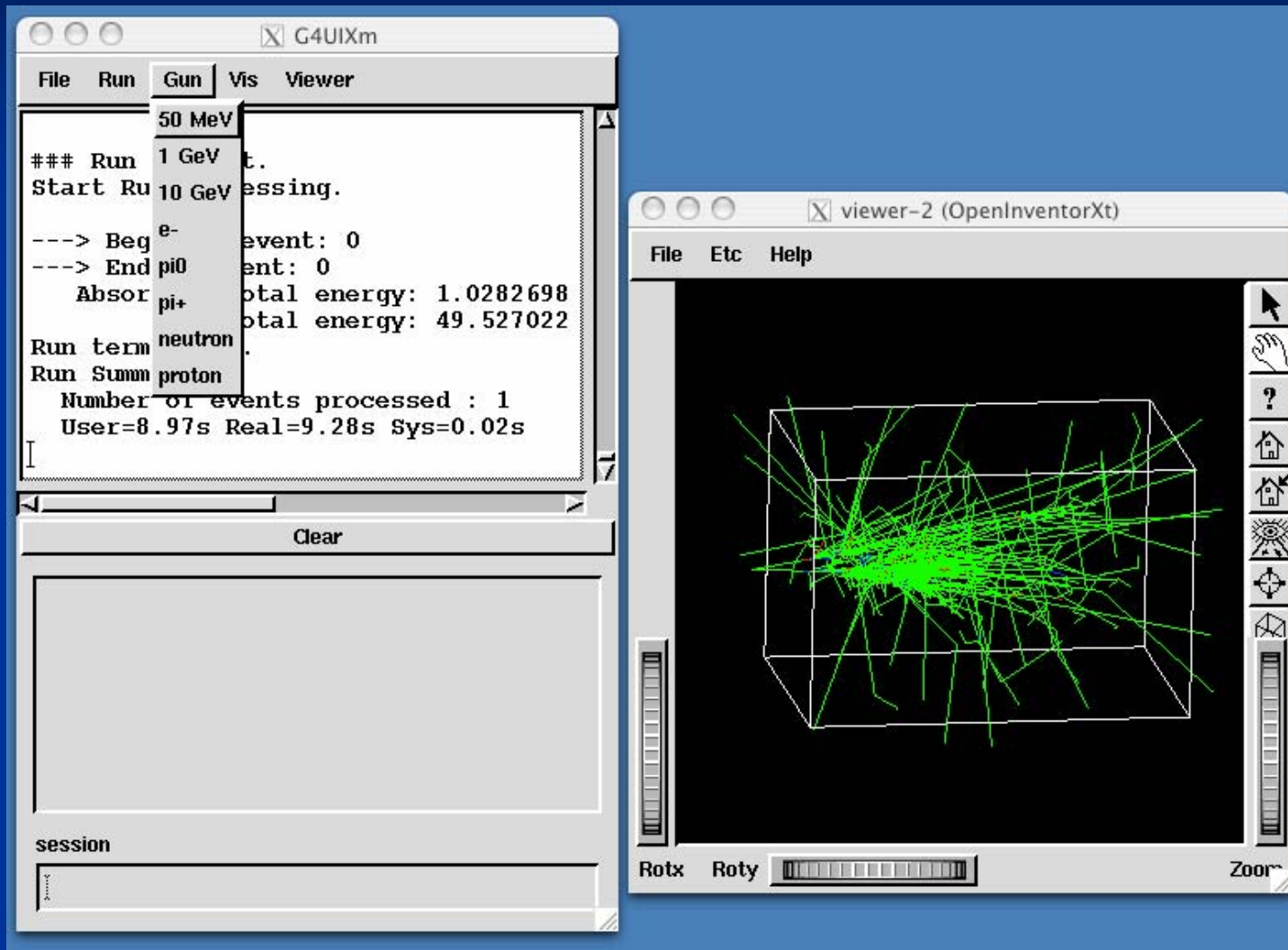

HepRep

- /vis/open HepRepFile

- Features
 - Create a file to view in the
 - WIRED3 HepRep Browser
 - WIRED4 JAS Plugin
 - or FRED Event Display
 - Wireframe or simple area fills (not photorealistic)
 - Many interactive features
 - zoom, rotate, translate
 - click to show attributes (momentum, etc.)
 - special projections (FishEye, etc.)
 - control visibility from hierarchical (tree) view of data
 - Hierarchical view of the geometry
 - WIRED3 and WIRED4 can export to many vector graphic formats (PostScript, PDF, etc.)

- Supported by Joseph Perl and Mark Donszelmann

WIRED3: Pick to Show Physics Attributes

Picked on this volume to show

- Material
- Density
- Radlen
- etc

Picked on this trajectory to show

- Particle ID
- Charge
- Momentum
- etc.

The screenshot displays the WIRED3 software interface with two windows open. The top window, titled 'Selected...', shows a table of attributes for a selected volume:

Attribute	Value
State	3
LVol	magneticL...
Material	Air
Solid	magneticT...
Density	8.05154e...
EType	G4Tubs
Radlen	28516

The bottom window, titled 'Selected Item(s)', shows a table of attributes for a selected trajectory:

Attribute	Value
.PDG	22
PID	613
PN	gamma
Ch	0
NTP	6
IMom	-74.6591 -409.67 296.17 keV
ID	61

The background shows a 3D visualization of a particle detector with trajectories. A purple arrow points from the text 'Picked on this volume to show' to a circular detector component. Another purple arrow points from the text 'Picked on this trajectory to show' to a trajectory passing through the detector.

WIRED3: Labeling by Any Attribute

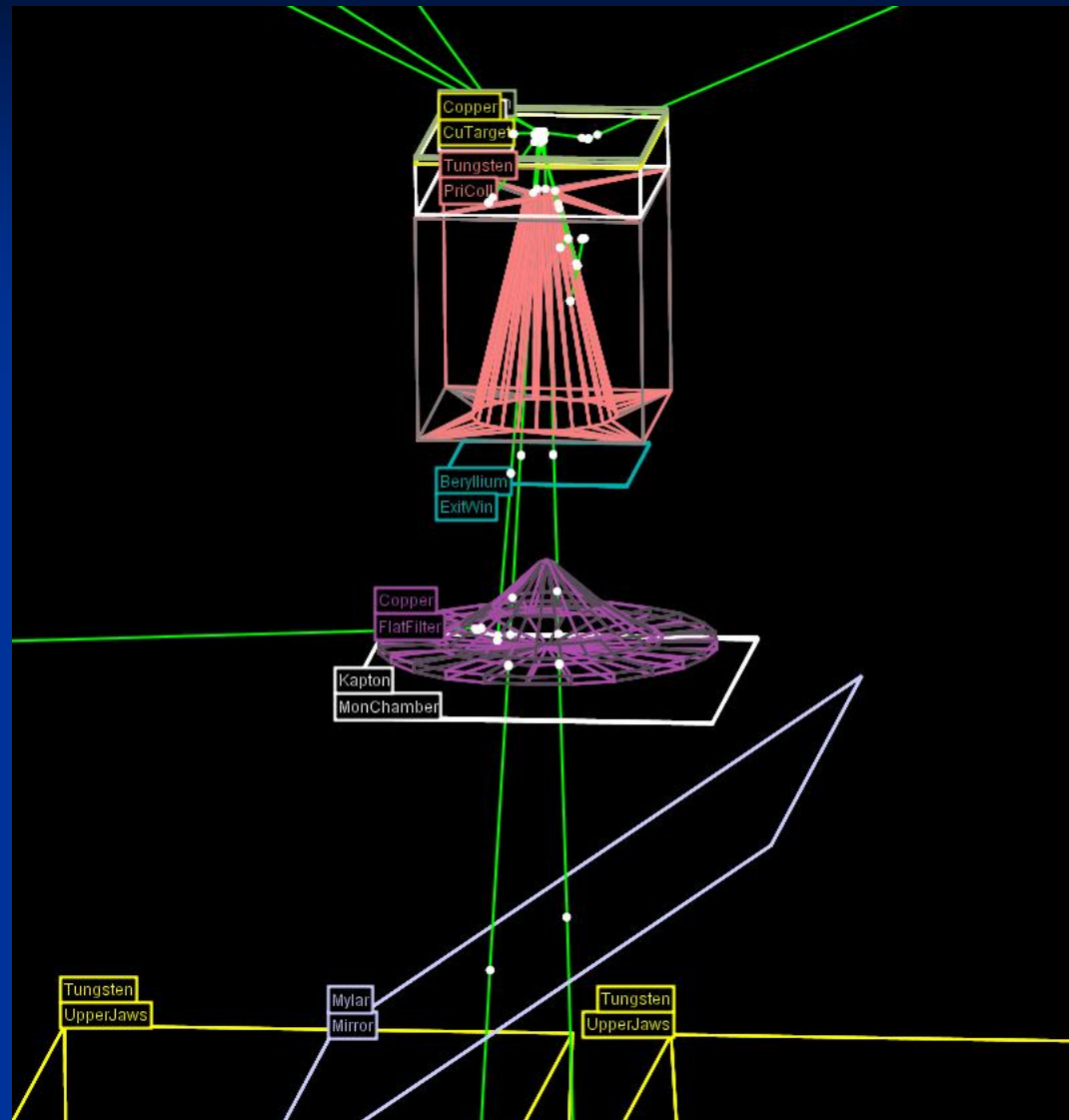

WIRED3: Cut by Any Attribute

The image displays two overlapping windows from the WIRED3 software. The background window is the 'WIRED3 HepRep Browser (version 3.13.0)', showing a 3D visualization of particle trajectories. The foreground window is the 'WIRED3 Cut Control' panel, which lists various attributes for filtering data.

WIRED3 Cut Control Panel Attributes:

Category	Attribute	Value
Overall	Density	=
	EType	=
	LVol	=
	Material	=
	Radlen	=
	Region	=
	RootRegion	=
	Solid	=
Trajectories	Ch	=
	ID	=
	IMag	=
	IMom	=
	NTP	=
	PDG	=
	PID	=
	PN	=
	Pos	=

Below the attribute list, a text input field contains the text: "Type a value and then hit the enter key".

The background window shows a 3D visualization of particle trajectories. A blue box highlights a set of trajectories with the label "IMag 1004.85 MeV". A green box highlights another set of trajectories with the label "IMag 27.6901 MeV". A blue box highlights a third set of trajectories with the label "IMag 31.0962 MeV". A green box highlights a fourth set of trajectories with the label "IMag 46.8678 MeV". The bottom right corner of the visualization area displays the text "Trajectories:IMag>25.0".

DAWN

- /vis/open DAWNFILE
- Features
 - Create a .prim file
 - Requires DAWN, available for all Linux and Windows systems
 - DAWN creates a rendered, photorealistic PostScript image
 - No interactive features once at PostScript stage
 - Highest quality technical rendering - vector PostScript
 - View or print from your favorite PostScript application
- Supported by Satoshi Tanaka
 - Recently ported DAWN, DAWNCUT and DAVID to FedoraCore 4.0 (g++ 4.0)

DAWN Examples

- From a repository of beautiful images at
 - http://geant4.kek.jp/~tanaka/GEANT4/ATLAS_G4_GIFFIG/

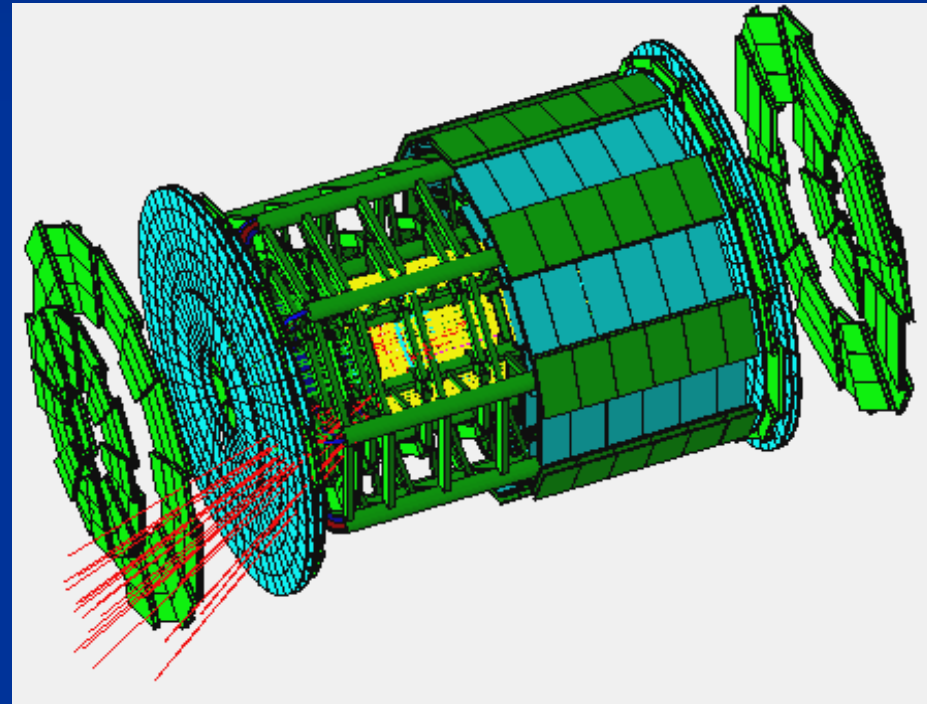
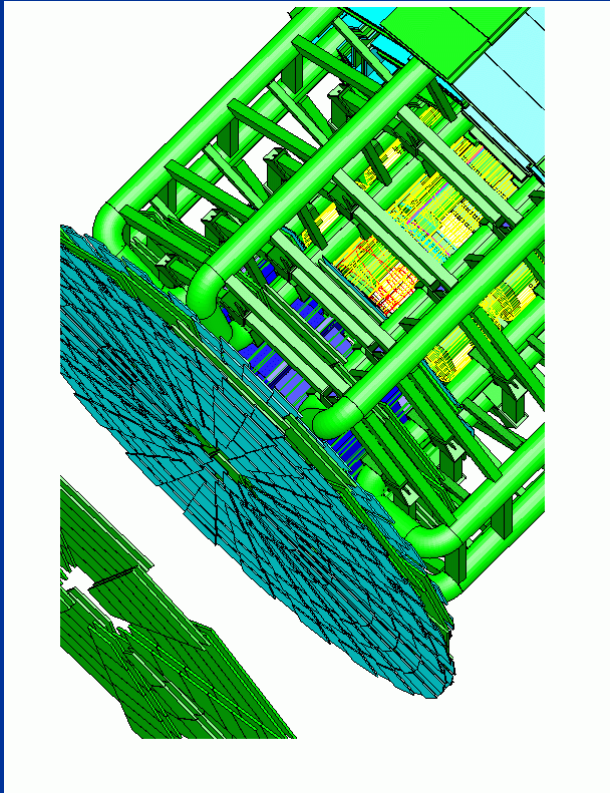

DAWN makes True Vector PostScript

- So when you zoom in with your PostScript browser, the images retain high resolution

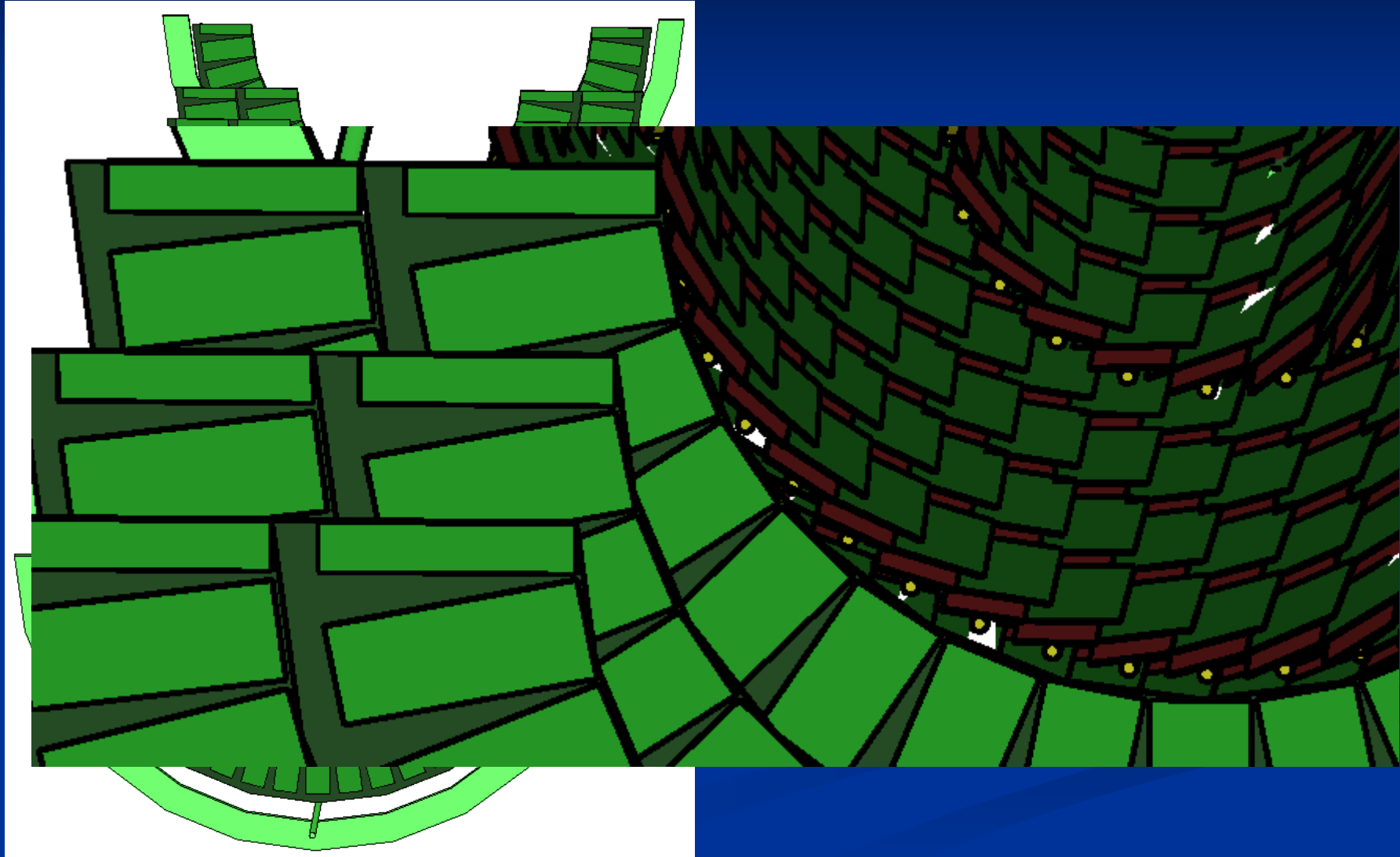

DAWNCUT and DAVID

- A standalone program, DAWNCUT, can perform a planar cut on a DAWN image.
 - DAWNCUT takes as input a .prim file and some cut parameters. Its output is a new .prim file to which the cut has been applied.
- Another standalone program, DAVID, can show you any volume overlap errors in your geometry.
 - DAVID takes as input a .prim file and outputs a new .prim file in which overlapping volumes have been highlighted.
- Details at <http://geant4.kek.jp/~tanaka/>

VRML

- `/vis/open VRML1FILE` or `/vis/open VRML2FILE`
- Features
 - Create a file to view in any VRML browser (some as web browser plug-ins).
 - Requires VRML browser (many different choices for different operating systems).
 - Rendered, photorealistic image with some interactive features
 - zoom, rotate, translate
 - Limited printing ability (pixel graphics, not vector graphics)
- Supported by Satoshi Tanaka

VRML

- Geant4 creates VRML File
 - /vis/open VRML1FILE or /vis/open VRML2FILE
- View file in a VRML Browser
 - Many free options, for example, here is one from octaga.com

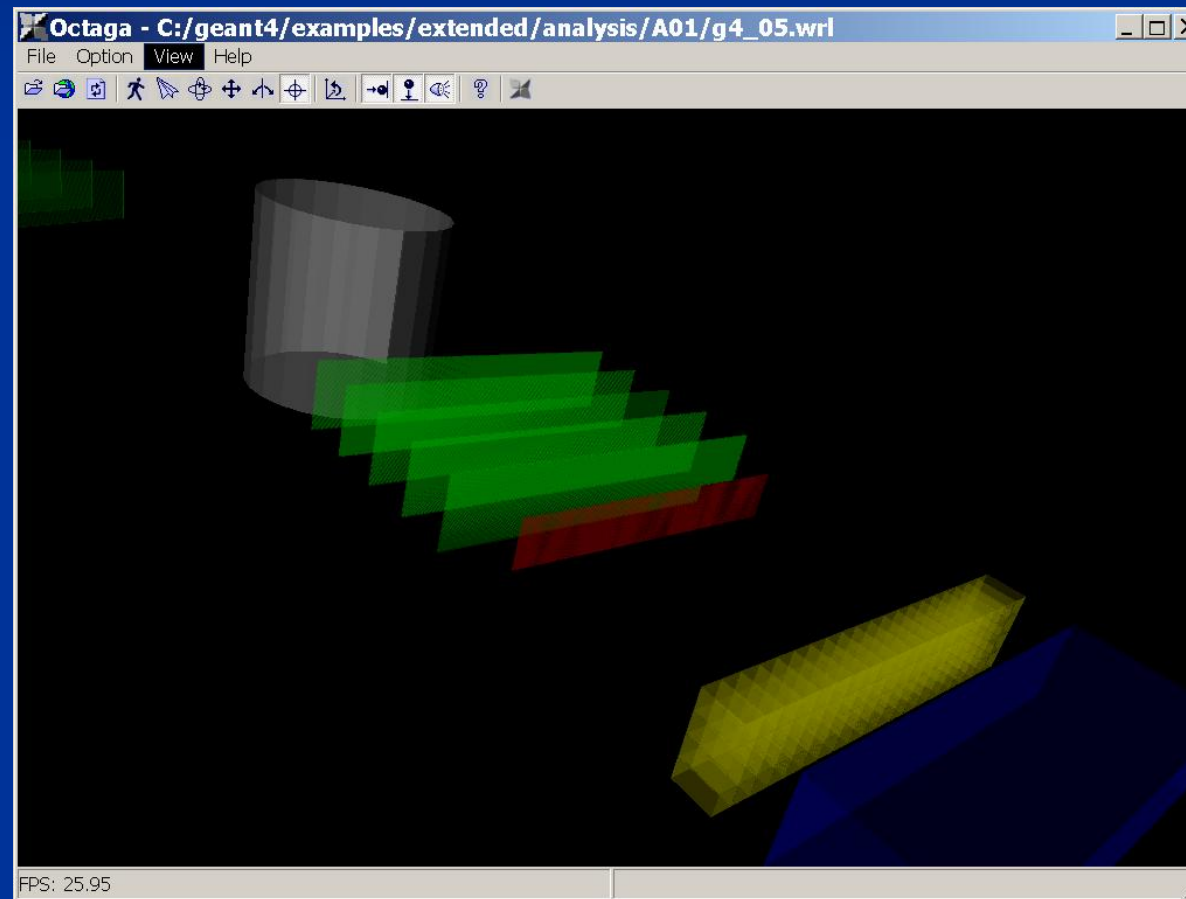

RayTracer

- /vis/open RayTracer
- Features
 - Create a jpeg file
 - Forms image by using Geant4's own tracking to follow photons through the detector
 - Can show geometry but not trajectories
 - Can render any geometry that Geant4 can handle (such as Boolean solids) - no other Vis driver can handle every case
 - Supports shadows, transparency and mirrored surfaces
- As of release Geant4.8.0, also now RayTracerX
 - /vis/open RayTracerX
 - Simultaneously renders to screen and to jpeg file, so that you can watch as the rendering grows progressively smoother
- Supported by Makoto Asai and John Allison

RayTracer Shows Shadows

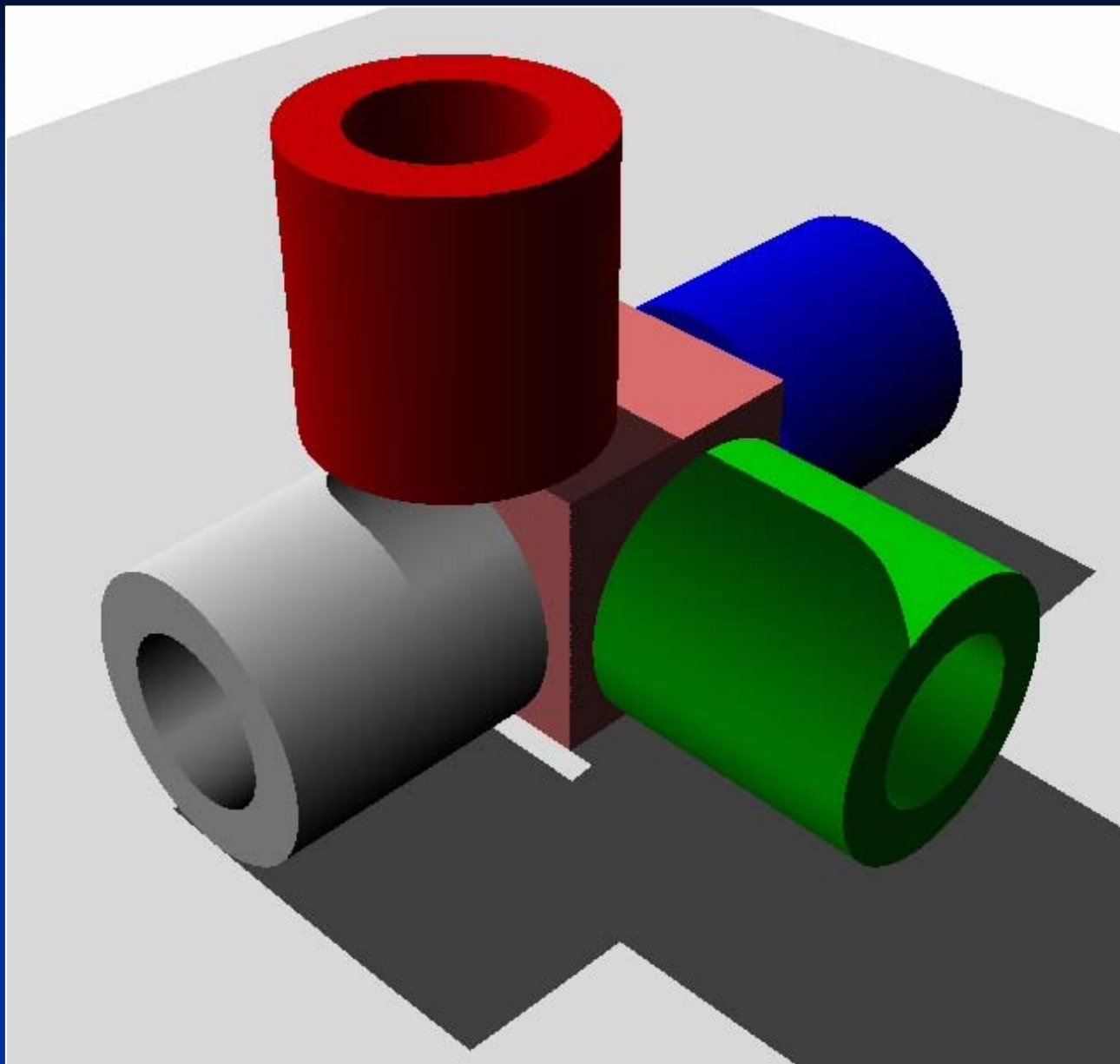

RayTracer Supports Transparency

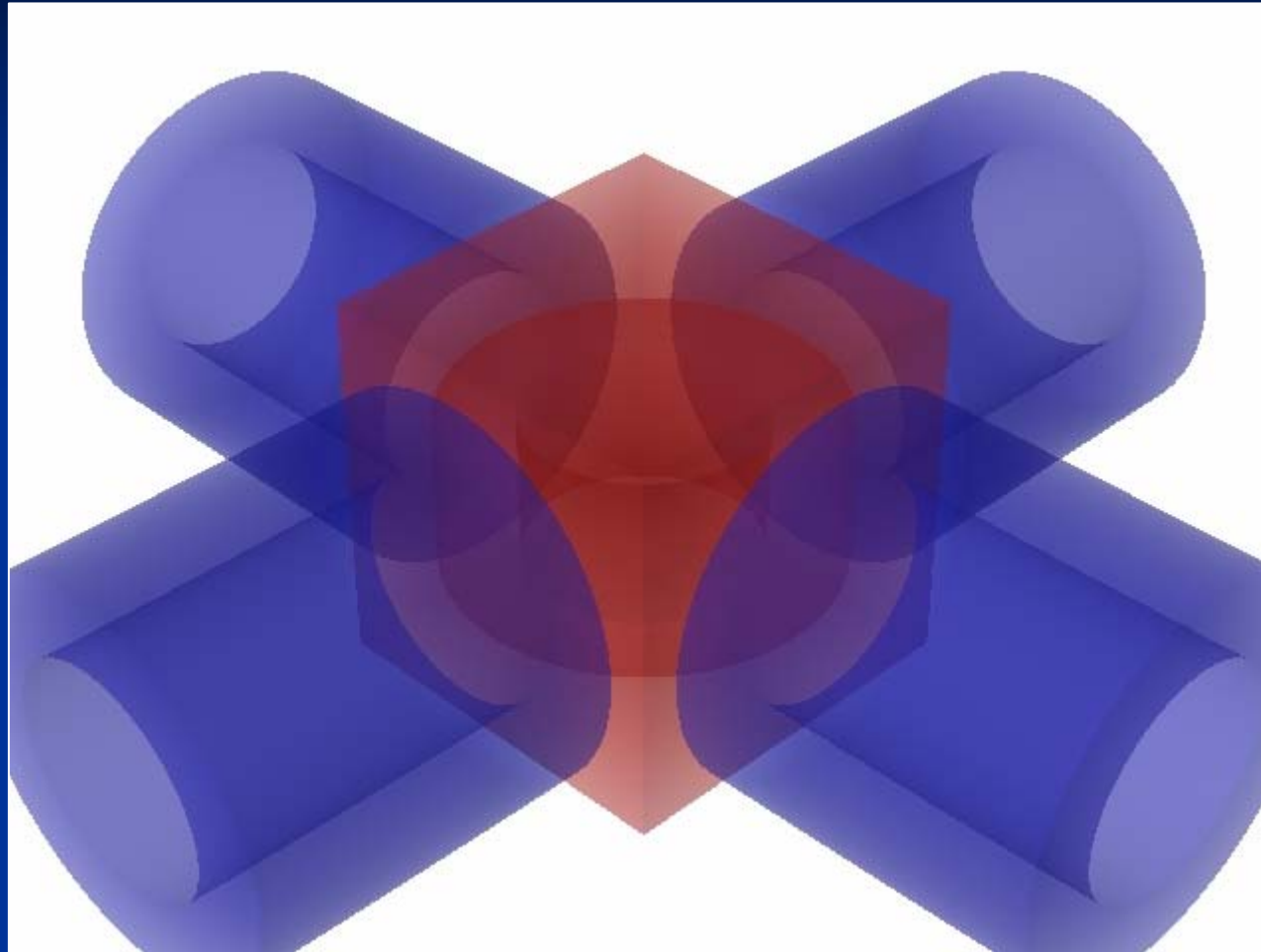

RayTracer Handles Mirrored Surfaces

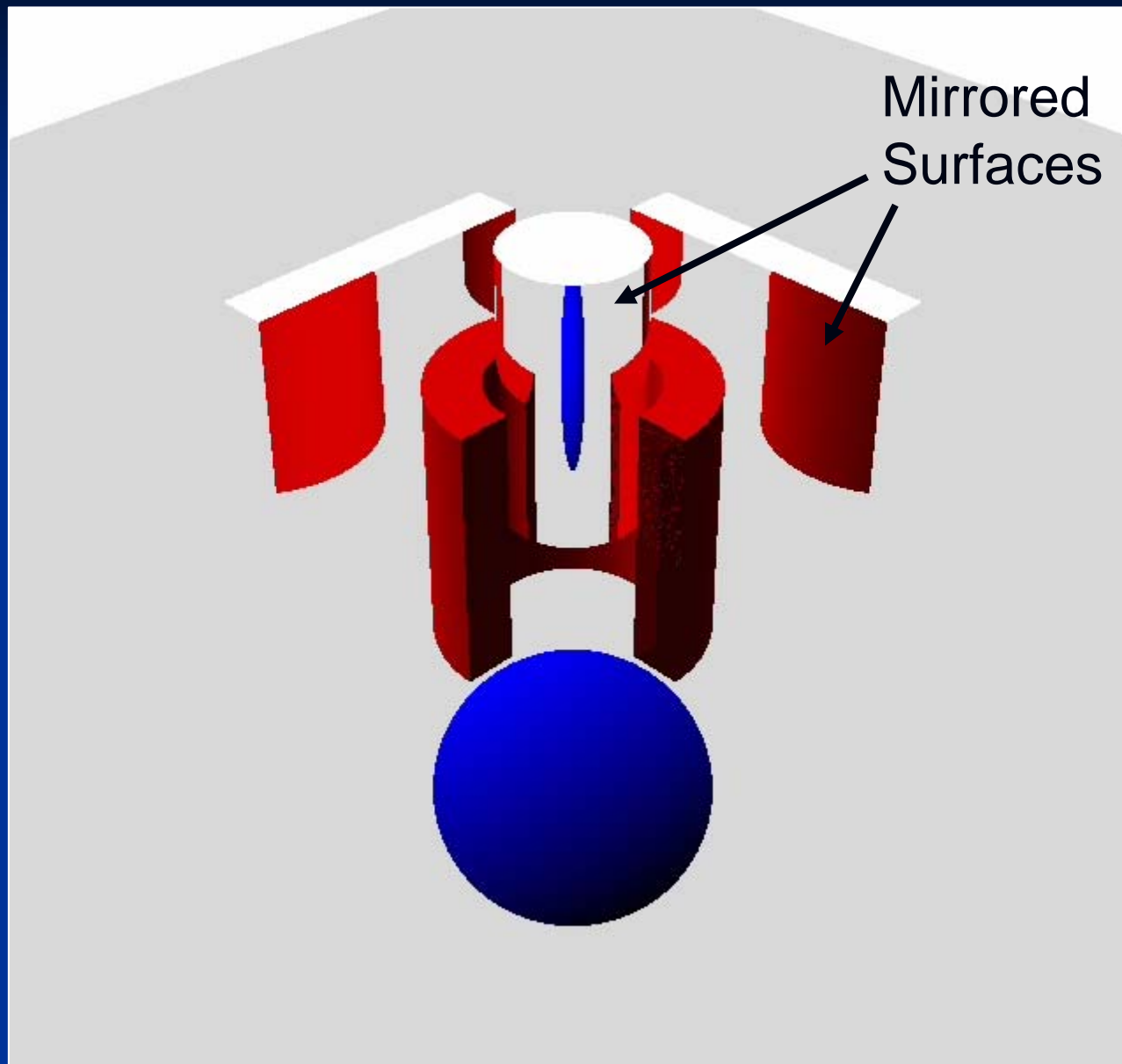

RayTracer Handles Boolean Solids

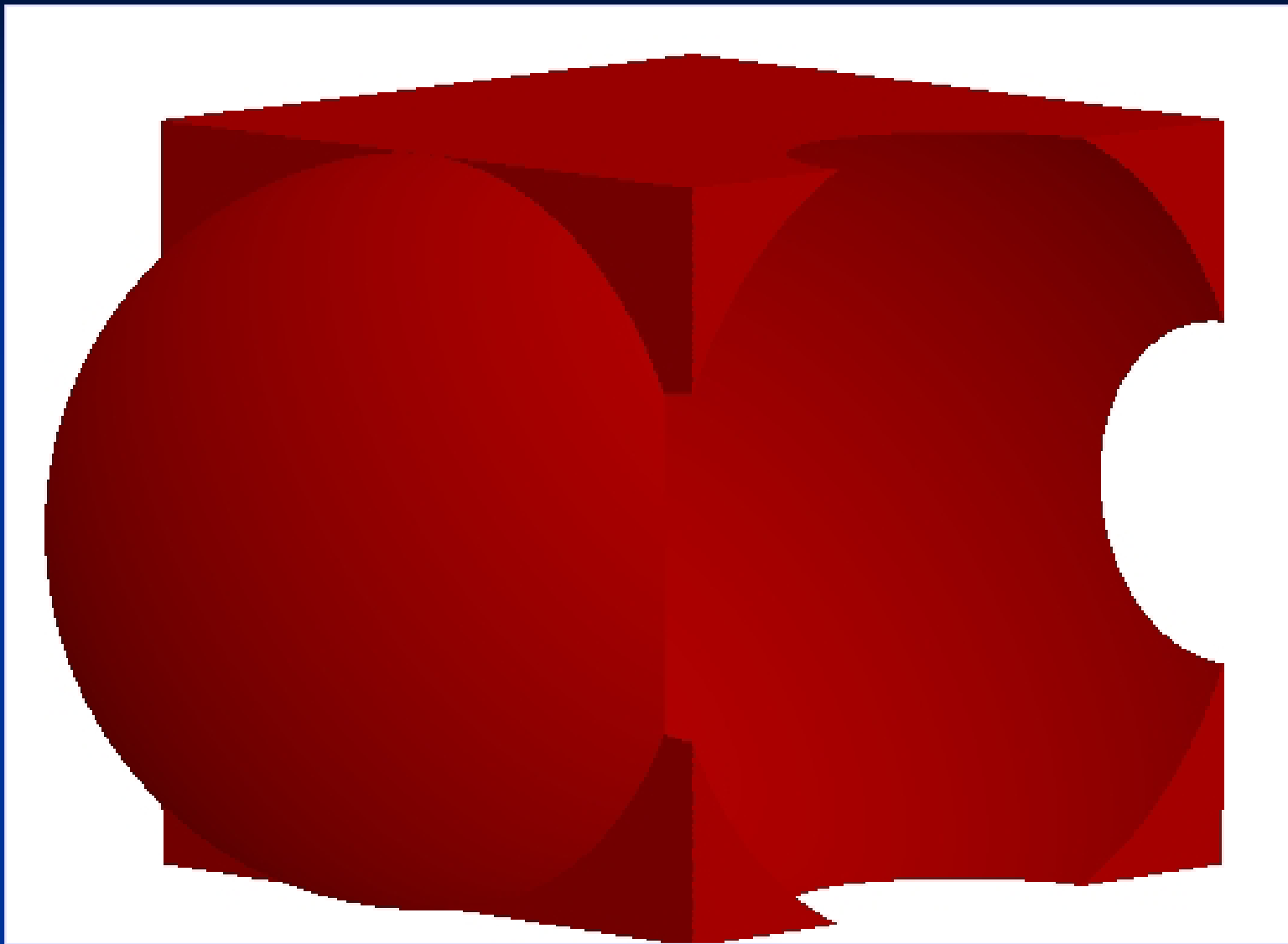

RayTracerX

- New since Geant4.8.0
- In addition to
 - `/vis/open RayTracer`
- You have the option of
 - `/vis/open RayTracerX`
- Builds same jpeg file as RayTracer, but simultaneously renders to screen so you can watch as rendering grows progressively smoother.
- Means you can abort and retry the rendering with different view parameters without having to wait for the complete refinement of the image.

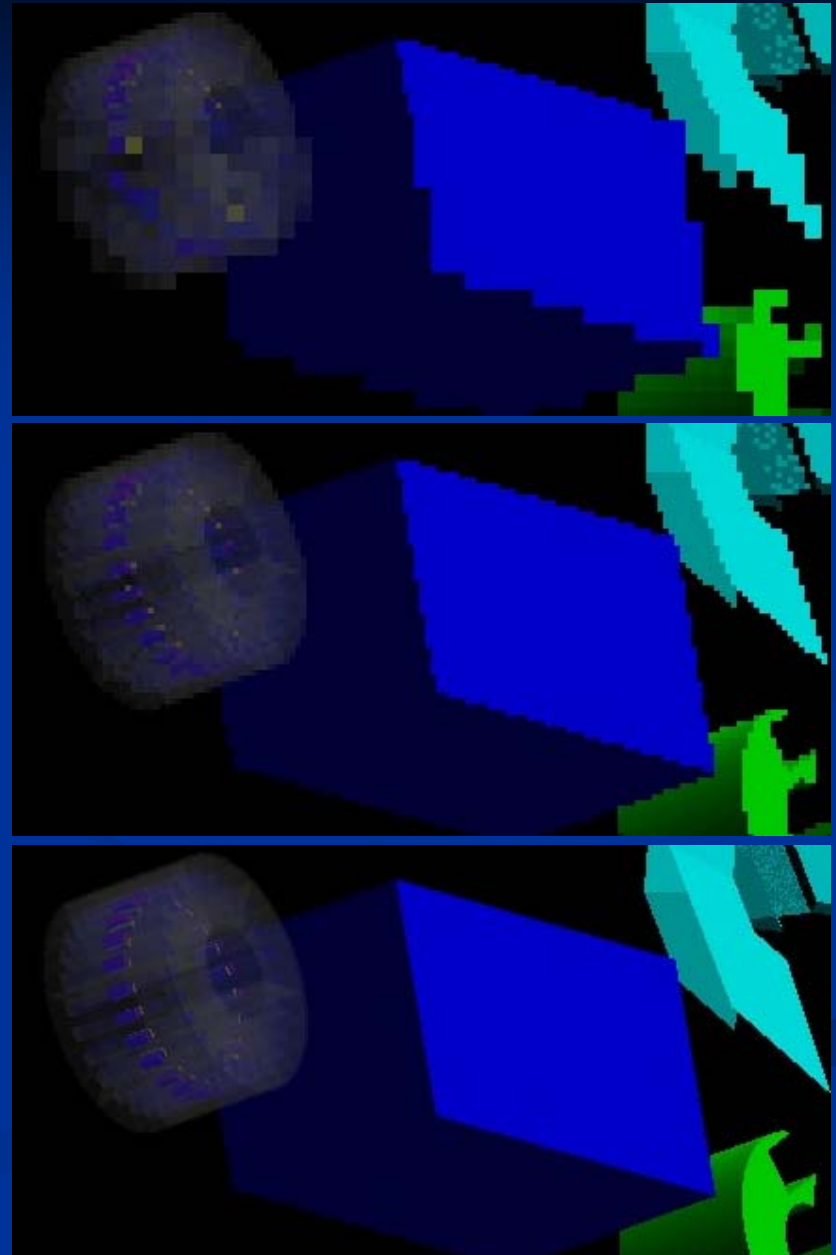

ASCIITree

- `/vis/open ATree`
- Features
 - Text dump of the geometry hierarchy
 - Not graphical
 - Control over level of detail to be dumped
 - Can calculate mass and volume of any hierarchy of volumes
- Supported by John Allison

ASCIITree

- ASCIITREE is a visualization driver that is not actually graphical, but that dumps the hierarchy as a simple text tree.
 - `/vis/open ATree`
- `/vis/viewer/flush`
 - `"worldPhysical":0`
 - `"magneticPhysical":0`
 - `"firstArmPhysical":0`
 - `"hodoscope1Physical":0`
 - `"hodoscope1Physical":1` (repeated placement)
 - `"hodoscope1Physical":2` (repeated placement)
 - `"hodoscope1Physical":3` (repeated placement)
 - `"hodoscope1Physical":4` (repeated placement)
- Can be set to various levels of detail
 - `/vis/ASCIITree/verbose <verbosity>`
 - 0: prints physical volume name.
 - 1: prints logical volume name.
 - 2: prints solid name and type.
 - 3: prints volume and density of solid.
 - 4: calculates and prints mass(es) of volume(s) in scene.
 - By default, shows only daughters of first placement and not repeat replicas.
 - Add 10 to the above to also show repeated placements and replicas.

ASCIITree: Calculate Volume and Mass

- At verbosity level 4, ASCIITree calculates the mass of the complete geometry tree taking into account daughters up to the depth specified for each physical volume.
- The calculation involves subtracting the mass of that part of the mother that is occupied by each daughter and then adding the mass of the daughter, and so on down the hierarchy.
- `/vis/ASCIITree/Verbose 4`
- `/vis/viewer/flush`
- `"HadCalorimeterPhysical":0 / "HadCalorimeterLogical" / "HadCalorimeterBox"(G4Box), 1.8 m3 , 11.35 g/cm3`
 - `"HadCalColumnPhysical":-1 (10 replicas) / "HadCalColumnLogical" / "HadCalColumnBox"(G4Box), 180000 cm3, 11.35 g/cm3`
 - `"HadCalCellPhysical":-1 (2 replicas) / "HadCalCellLogical" / "HadCalCellBox"(G4Box), 90000 cm3, 11.35 g/cm3`
 - `"HadCalLayerPhysical":-1 (20 replicas) / "HadCalLayerLogical" / "HadCalLayerBox"(G4Box), 4500 cm3, 11.35 g/cm3`
 - `"HadCalScintiPhysical":0 / "HadCalScintiLogical" / "HadCalScintiBox"(G4Box), 900 cm3, 1.032 g/cm3`
- Calculating mass(es)...
 - Overall volume of "worldPhysical":0, is 2400 m³
 - Mass of tree to unlimited depth is 22260.5 kg

Summary of Visualization Drivers

We have Seven Visualization Drivers
with complimentary strengths.
All well supported.

- OpenGL
- OpenInventor
- HepRep/WIRED (and FRED)
- DAWN
- VRML
- RayTracer
- ASCII Tree

Detailed List of What Was Recently Done and What is Still To Do

I'll Spare you the Details.

We have more exciting things to show you in our limited time here today.

For the complete list of what has been done since release 8.0 and what is to do, see:

http://geant4.slac.stanford.edu/Presentations/vis/workplans/VisToDoList_20061011d.doc

and .pdf

Feedback welcome

Geant4 Visualization Resources

Geant4 Installation Guides

➤ <http://geant4.slac.stanford.edu/installation>

Hands on WIRED3 Tutorial

➤ <http://geant4.slac.stanford.edu/Presentations/vis/G4WIREDTutorial/G4WIREDTutorial.html>

Hands on DAWN Tutorial

➤ <http://geant4.slac.stanford.edu/Presentations/vis/G4DAWNTutorial/G4DAWNTutorial.html>

Hands on OpenGL Tutorial

➤ <http://geant4.slac.stanford.edu/Presentations/vis/G4OpenGLTutorial/G4OpenGLTutorial.html>

Geant4 Visualization Commands

➤ <http://geant4.slac.stanford.edu/Presentations/vis/G4VisCommands.ppt> (and .pdf)

Geant4 Advanced Visualization

➤ <http://geant4.slac.stanford.edu/Presentations/vis/G4VisAdvanced.ppt> (and .pdf)

On-line Documentation on Geant4 Visualization:

➤ <http://cern.ch/geant4/G4UsersDocuments/UsersGuides/ForApplicationDeveloper/html/Visualization>

List of Visualization Commands:

➤ <http://cern.ch/geant4/G4UsersDocuments/UsersGuides/ForApplicationDeveloper/html/Visualization/Ulcommands/vis.txt>

Another Presentation that Introduces Visualization,
with More Focus on Controlling Visualization from C++:

➤ <http://www.ge.infn.it/geant4/training/portland/visualisation.pdf>

For Questions or Comments: Geant4 Visualization Online Forum:

➤ <http://geant4-hn.slac.stanford.edu:5090/HyperNews/public/get/visualization.html>

References

- OpenScientist Home Page
<http://openscientist.lal.in2p3.fr>
- HepRep: a generic interface definition for HEP event display representables
<http://www.slac.stanford.edu/~perl/heprep>
- Fred: oh no, another event display (a HepRep client)
<http://www.fisica.uniud.it/~glast/FRED>
- WIRED3 HepRep Browser
<http://www.slac.stanford.edu/BFROOT/www/Computing/Graphics/Wired>
- DAWN Hot Information
<http://geant4.kek.jp/Geant4/vis>
- DAWN Home Page
http://geant4.kek.jp/~tanaka/DAWN/About_DAWN.html
- DAWNCUT Home Page
http://geant4.kek.jp/~tanaka/DAWN/About_DAWNCUT.html
- DAVID Home Page
http://geant4.kek.jp/~tanaka/DAWN/About_DAVID.html
- Satoshi Tanaka's GEANT4 Ritsumeikan University Group Home Page (more information on DAWN, sample PRIM files, images, etc.)
<http://geant4.kek.jp/~tanaka/>

And Now...

Jane Tinslay and John Allison will show you some very cool new features.