

CLIC

FIRST 3D STUDIES for the TURNAROUND AREA

John Osborne / A.Kosmicki

Collaboration with Alexandre Samoshkin / Claude Hauviller & Bernard Jeanneret

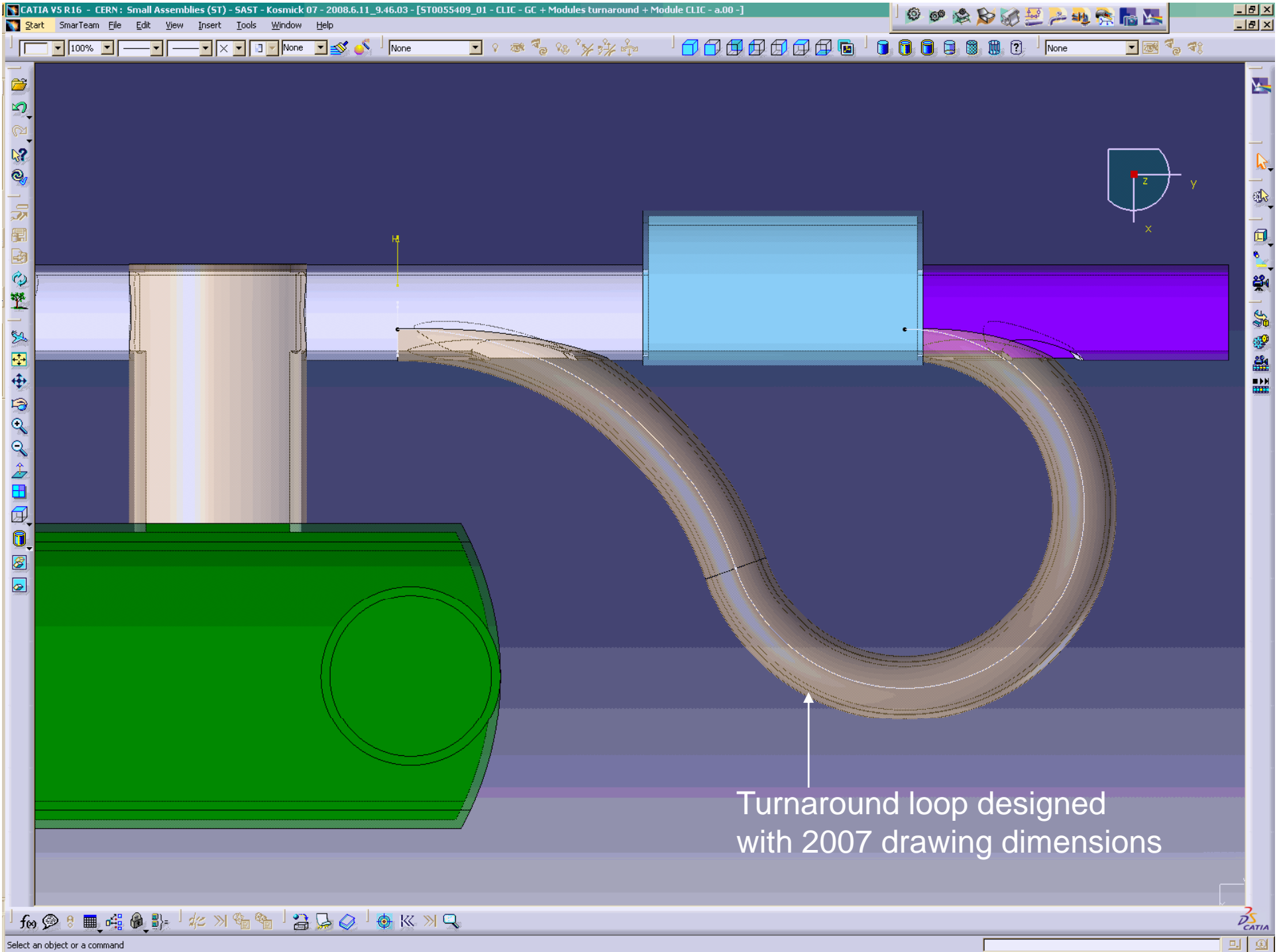

Turnaround loop designed with 2007 drawing dimensions

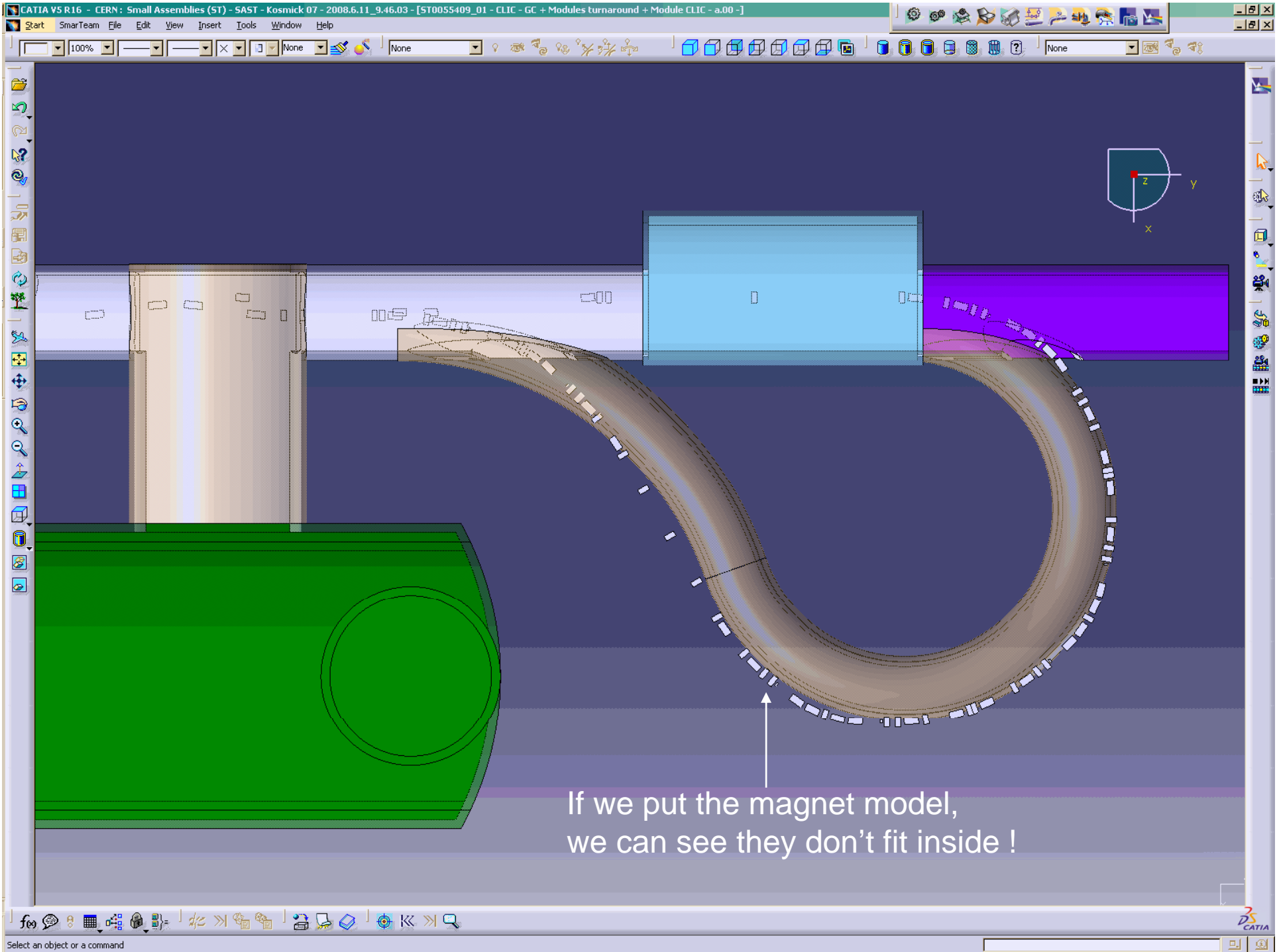

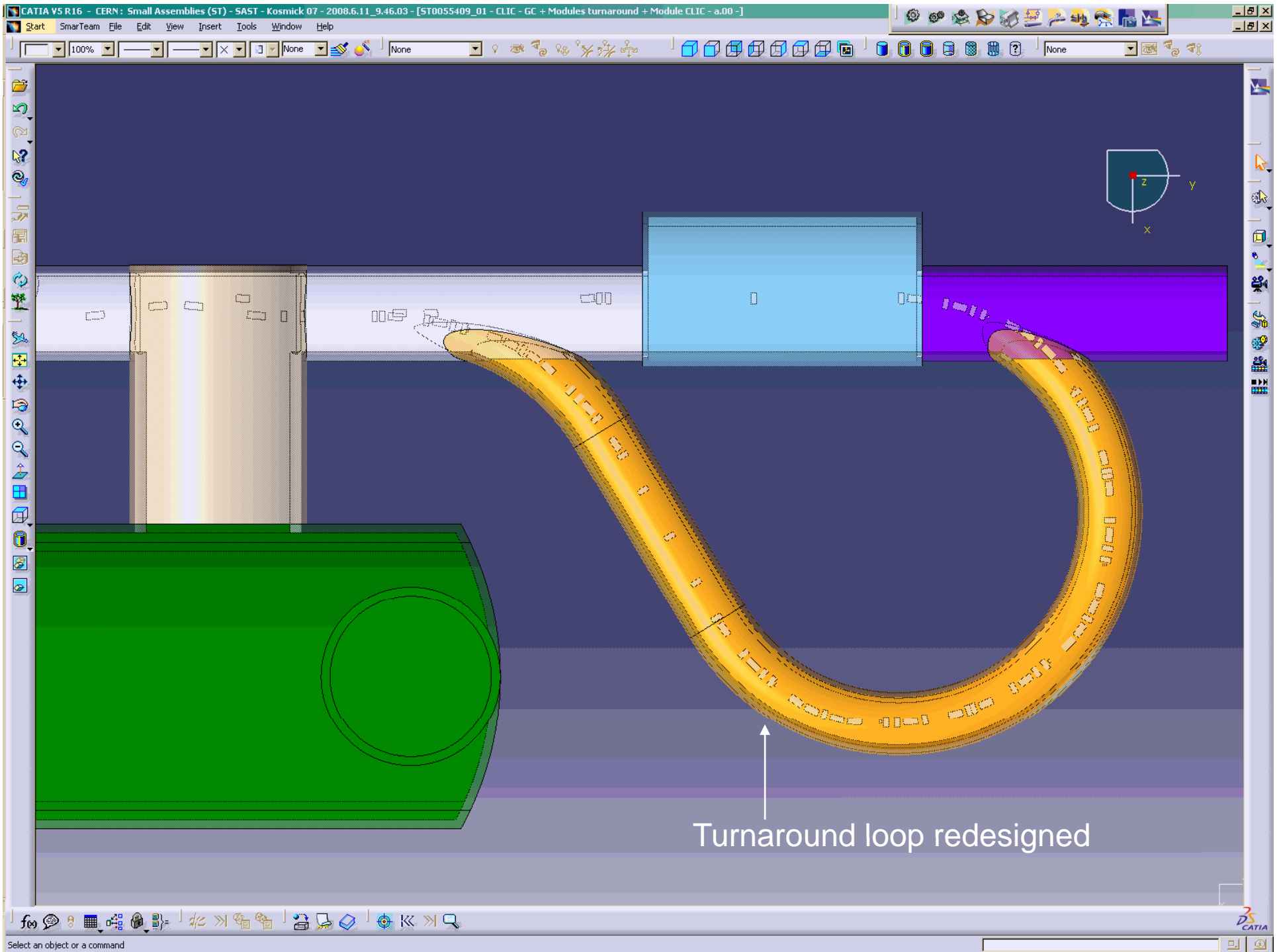

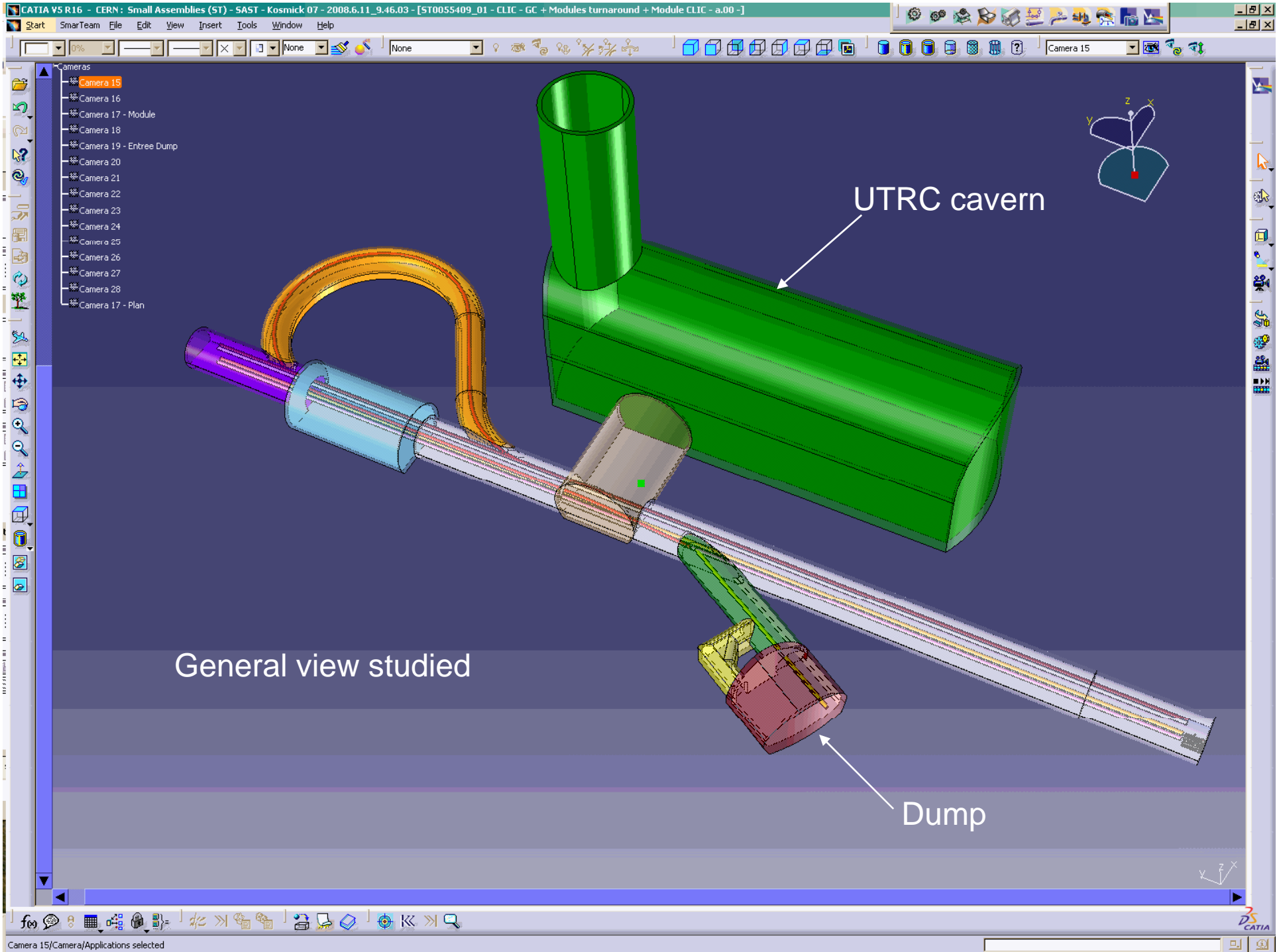

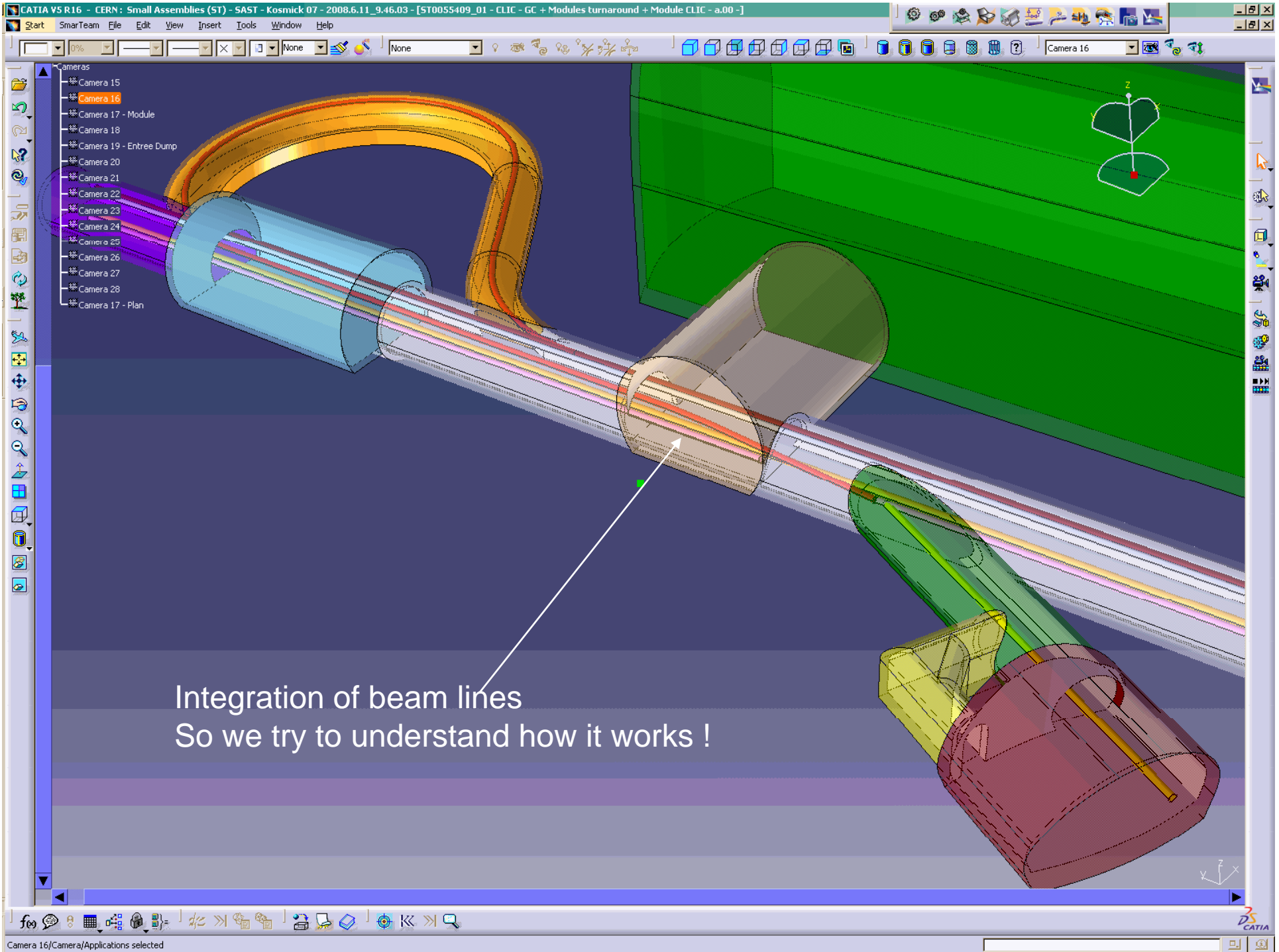

- Cameras
- Camera 15
- Camera 16
- Camera 17 - Module
- Camera 18
- Camera 19 - Entree Dump
- Camera 20
- Camera 21
- Camera 22
- Camera 23
- Camera 24
- Camera 25
- Camera 26
- Camera 27
- Camera 28
- Camera 17 - Plan

CLIC module
By Alexandre Samoshkin

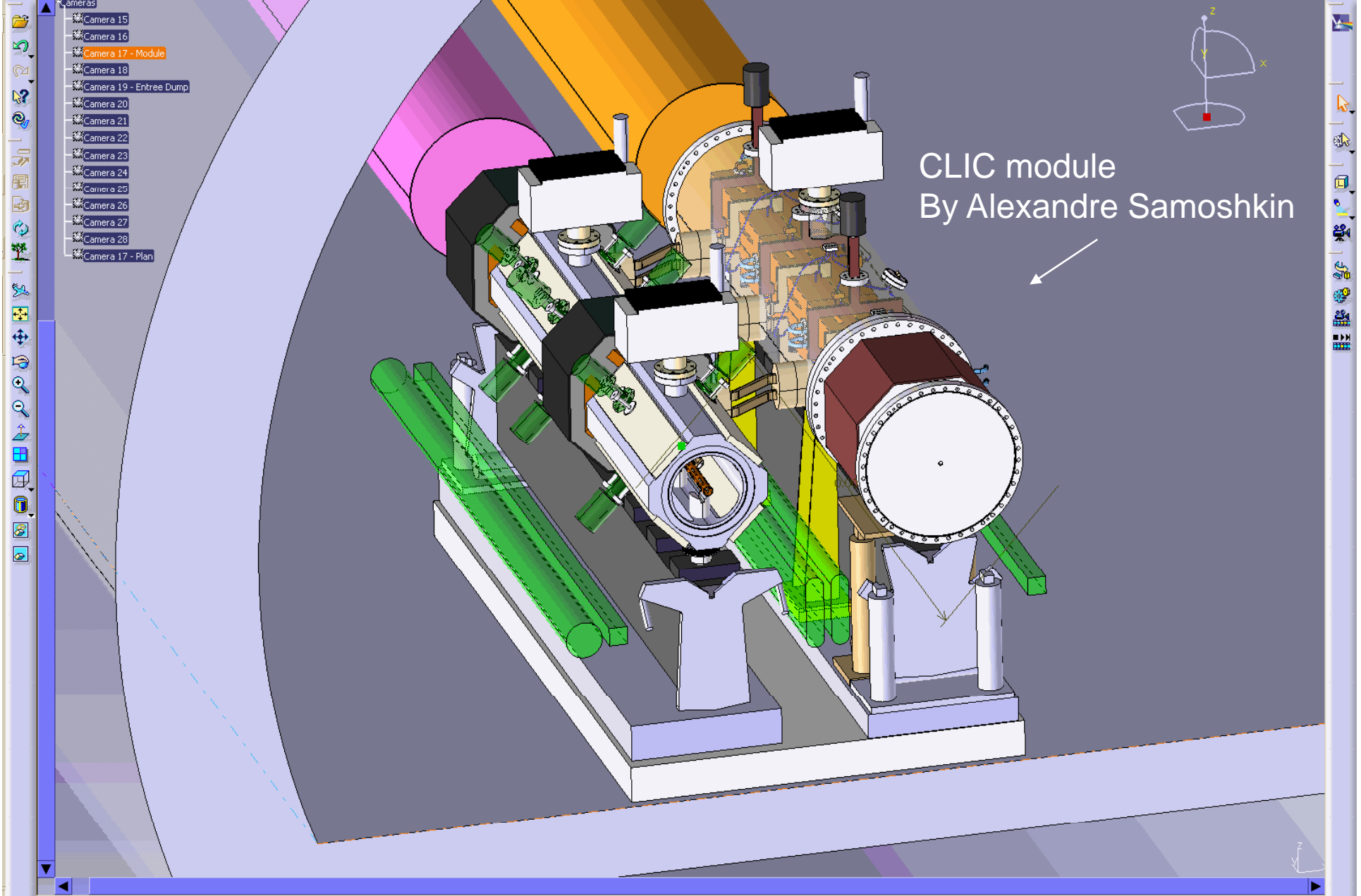

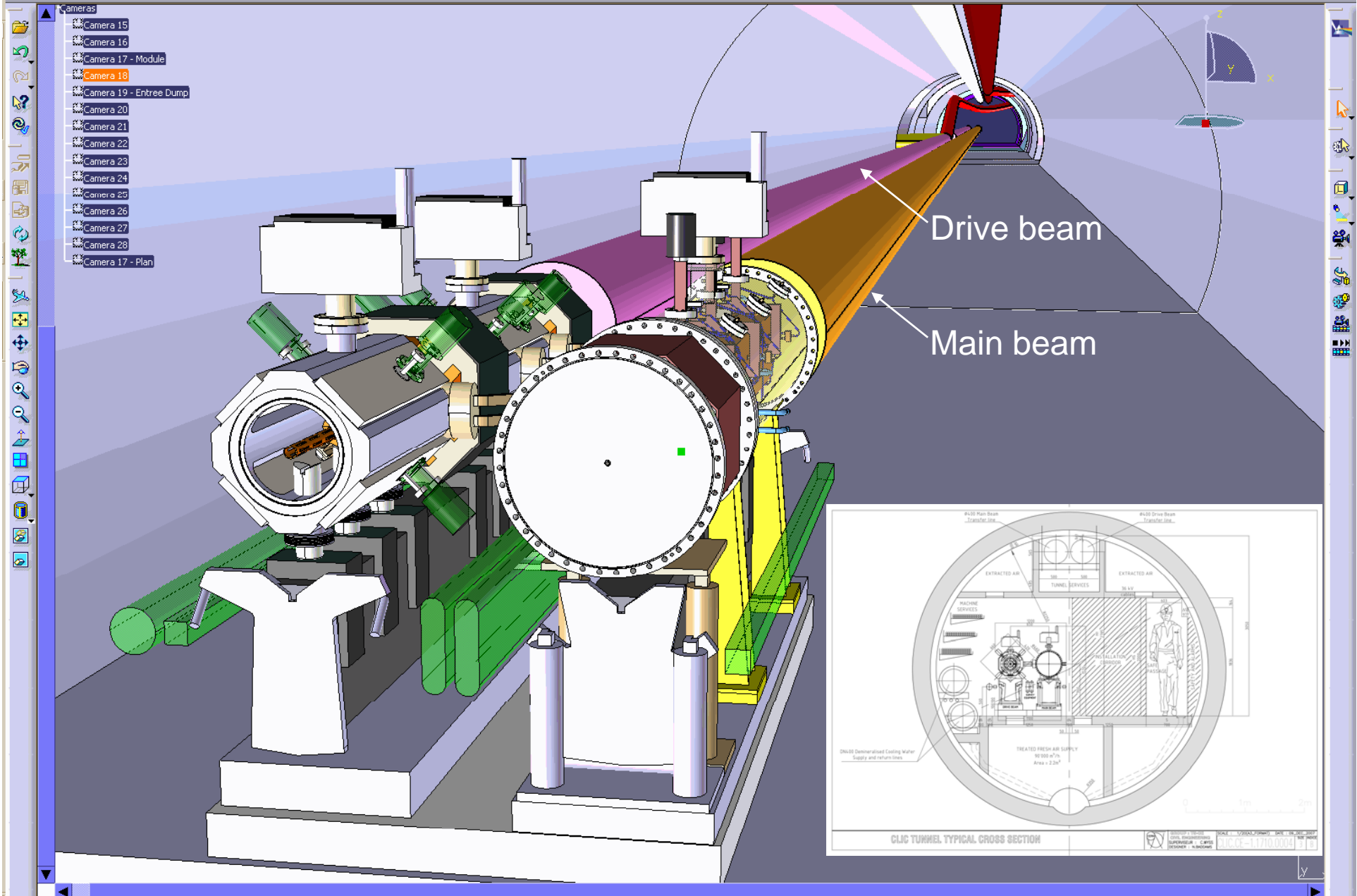

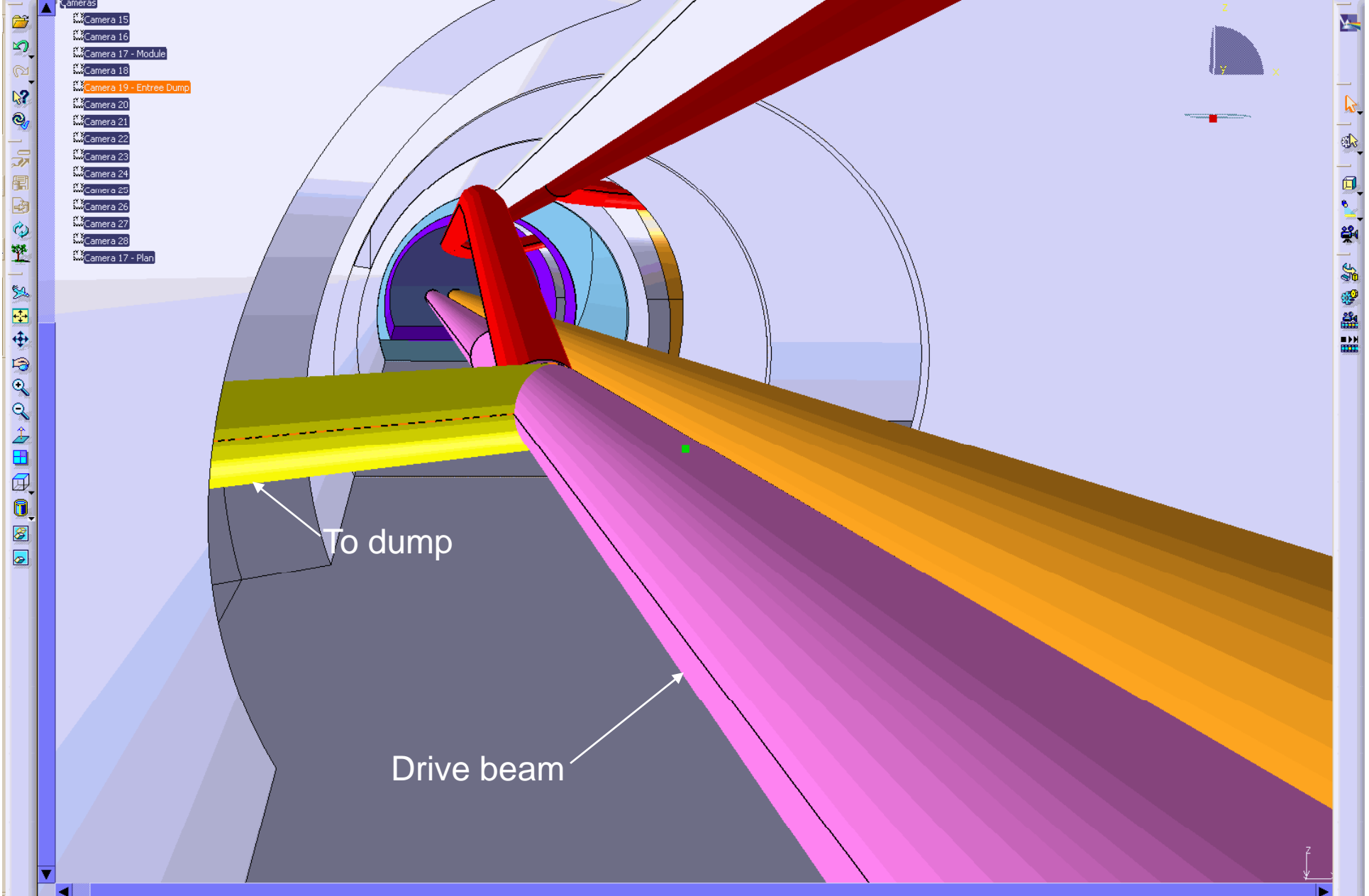

- Cameras
- Camera 15
- Camera 16
- Camera 17 - Module
- Camera 18
- Camera 19 - Entree Dump
- Camera 20
- Camera 21
- Camera 22
- Camera 23
- Camera 24
- Camera 25
- Camera 26
- Camera 27
- Camera 28
- Camera 17 - Plan

To dump

Drive beam

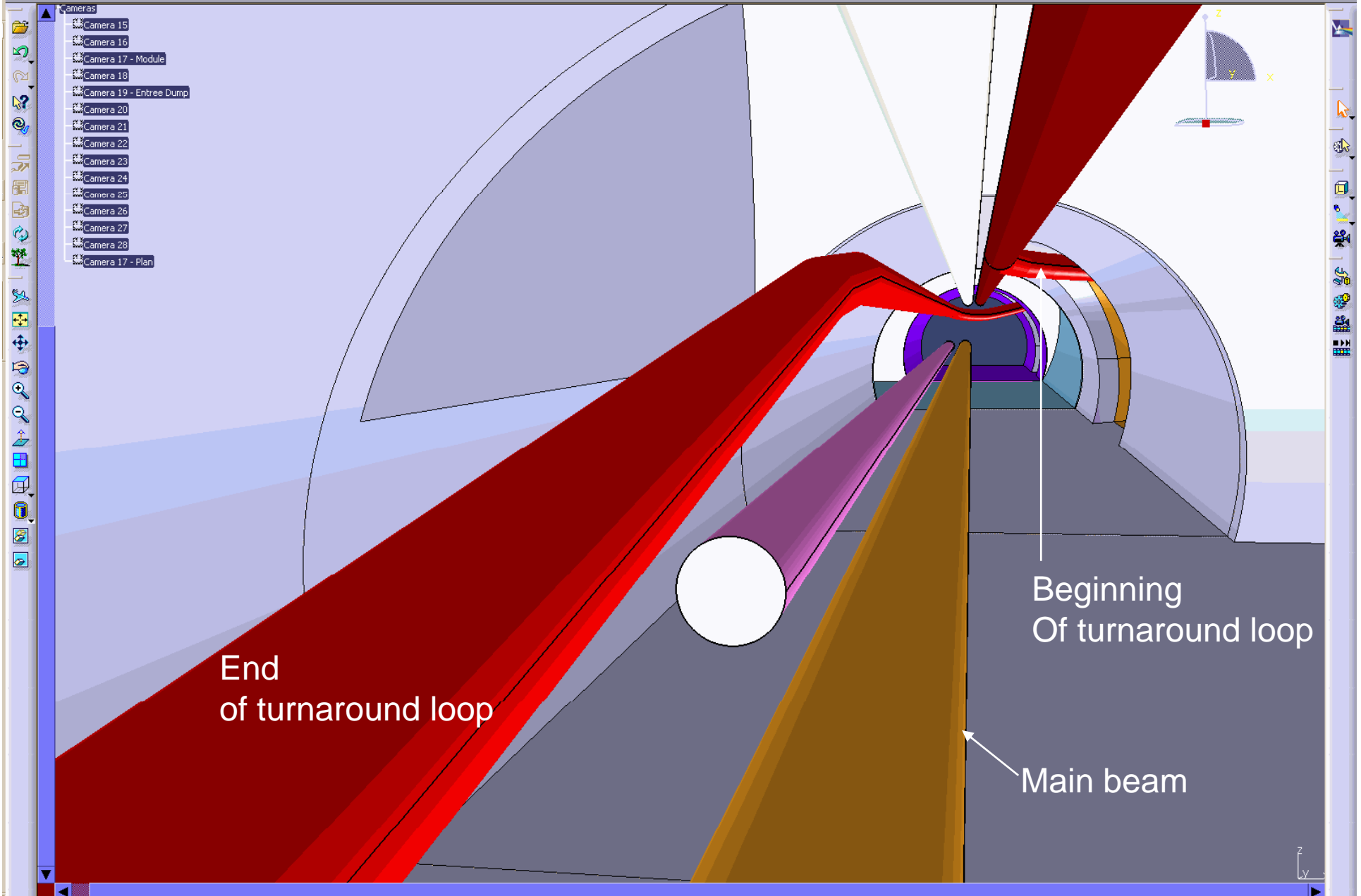

- Cameras
- Camera 15
- Camera 16
- Camera 17 - Module
- Camera 18
- Camera 19 - Entree Dump
- Camera 20
- Camera 21
- Camera 22
- Camera 23
- Camera 24
- Camera 25
- Camera 26
- Camera 27
- Camera 28
- Camera 17 - Plan

End of turnaround loop

Beginning Of turnaround loop

Main beam

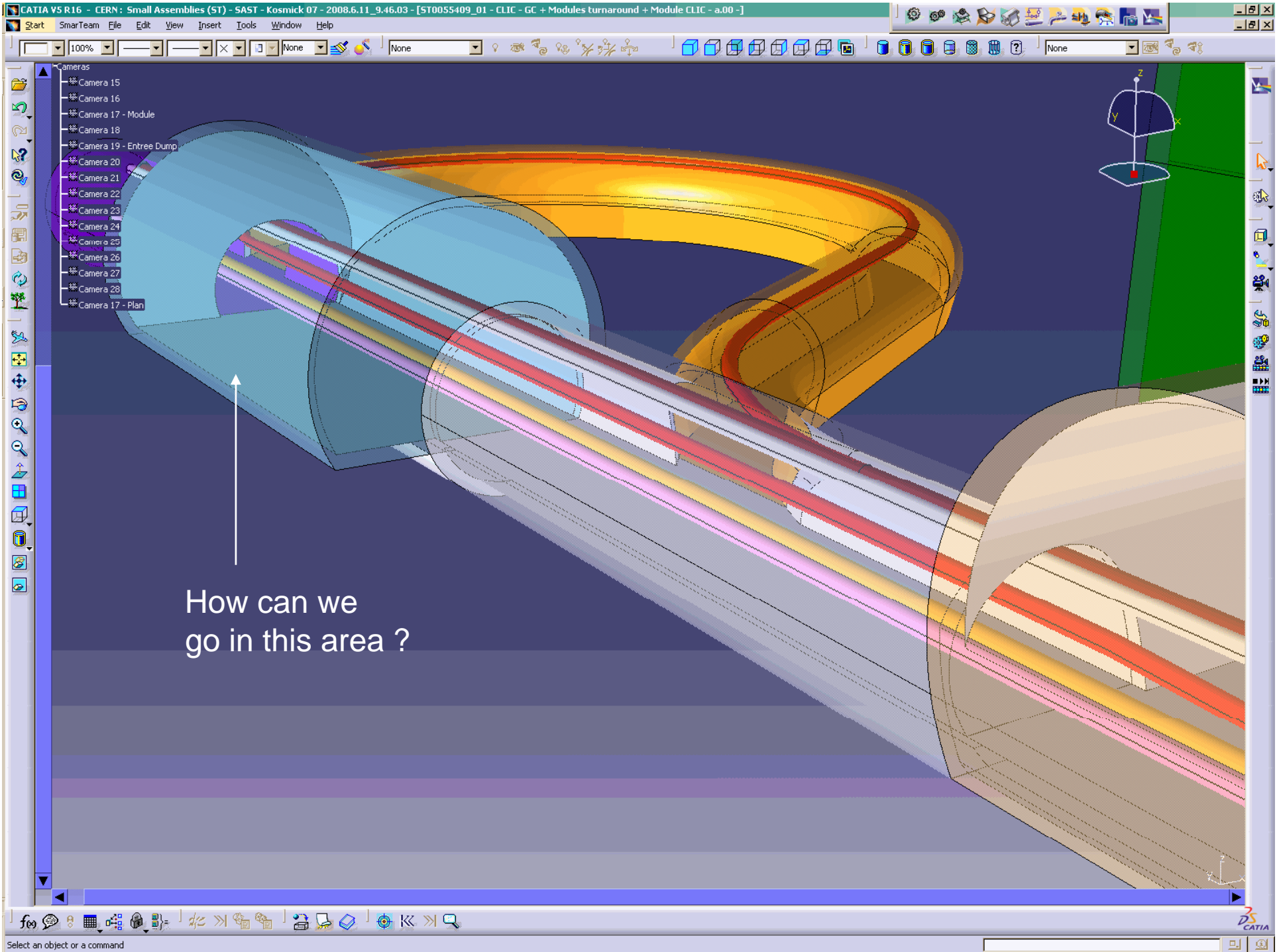

How can we go in this area ?

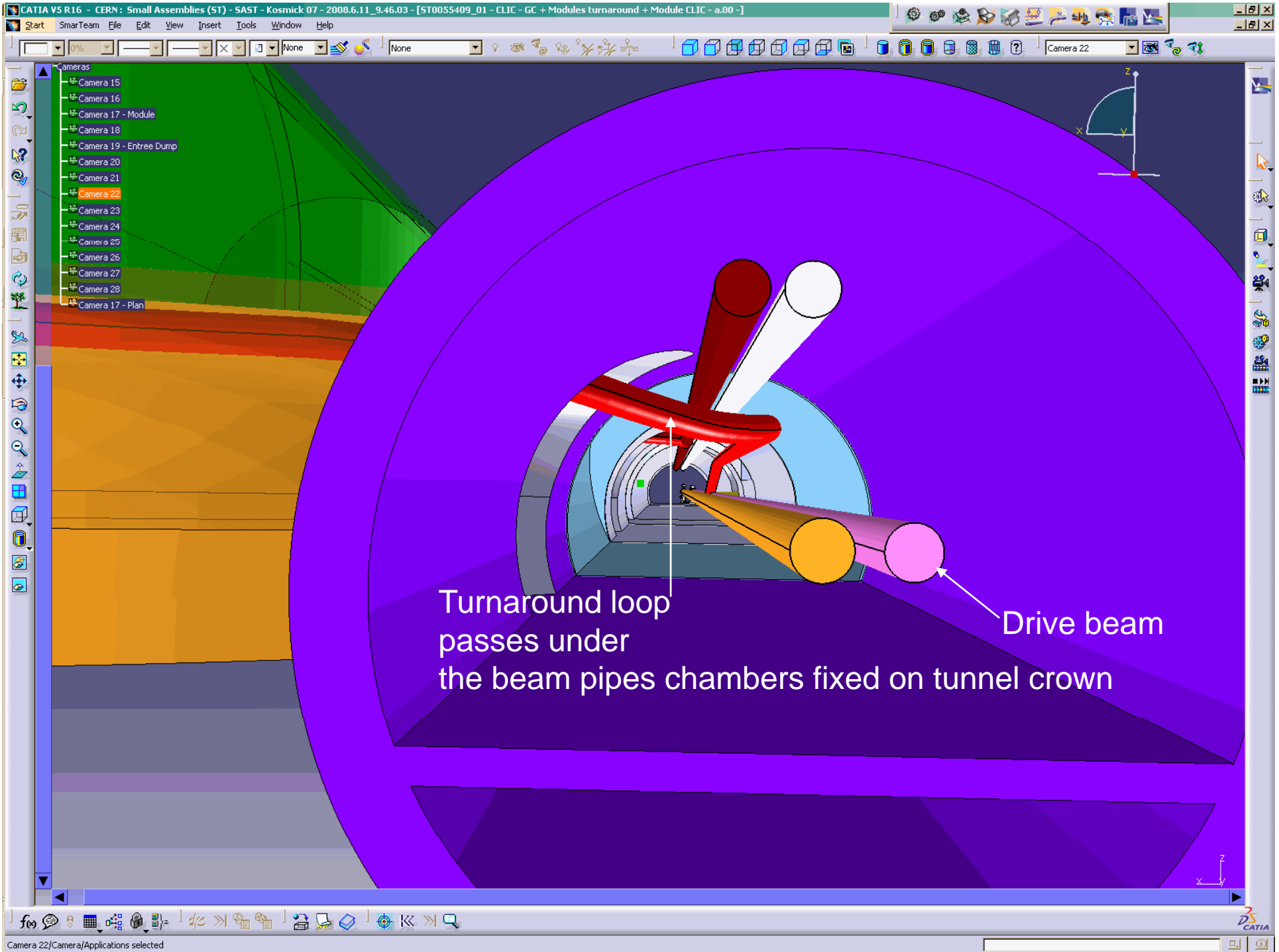

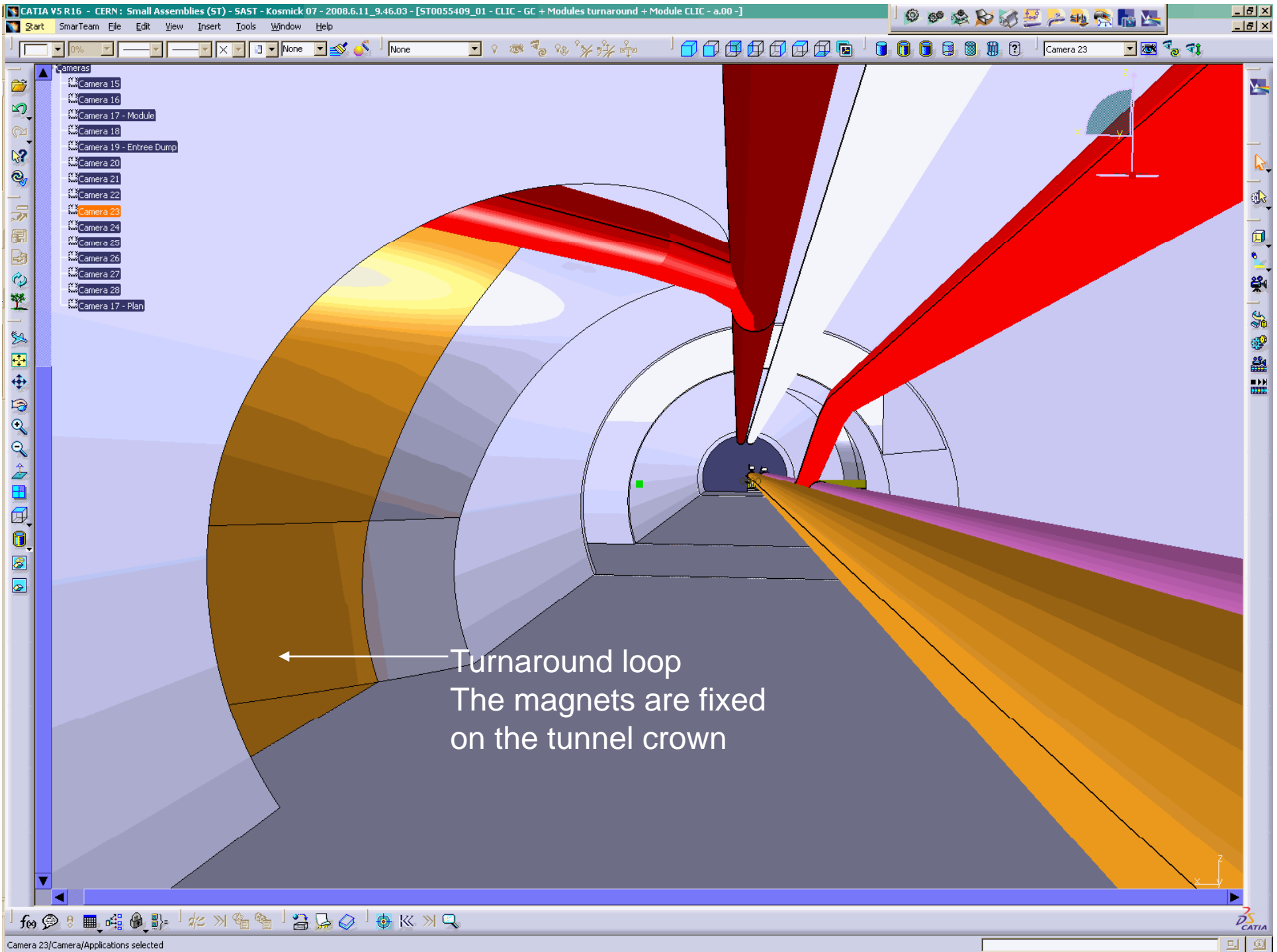

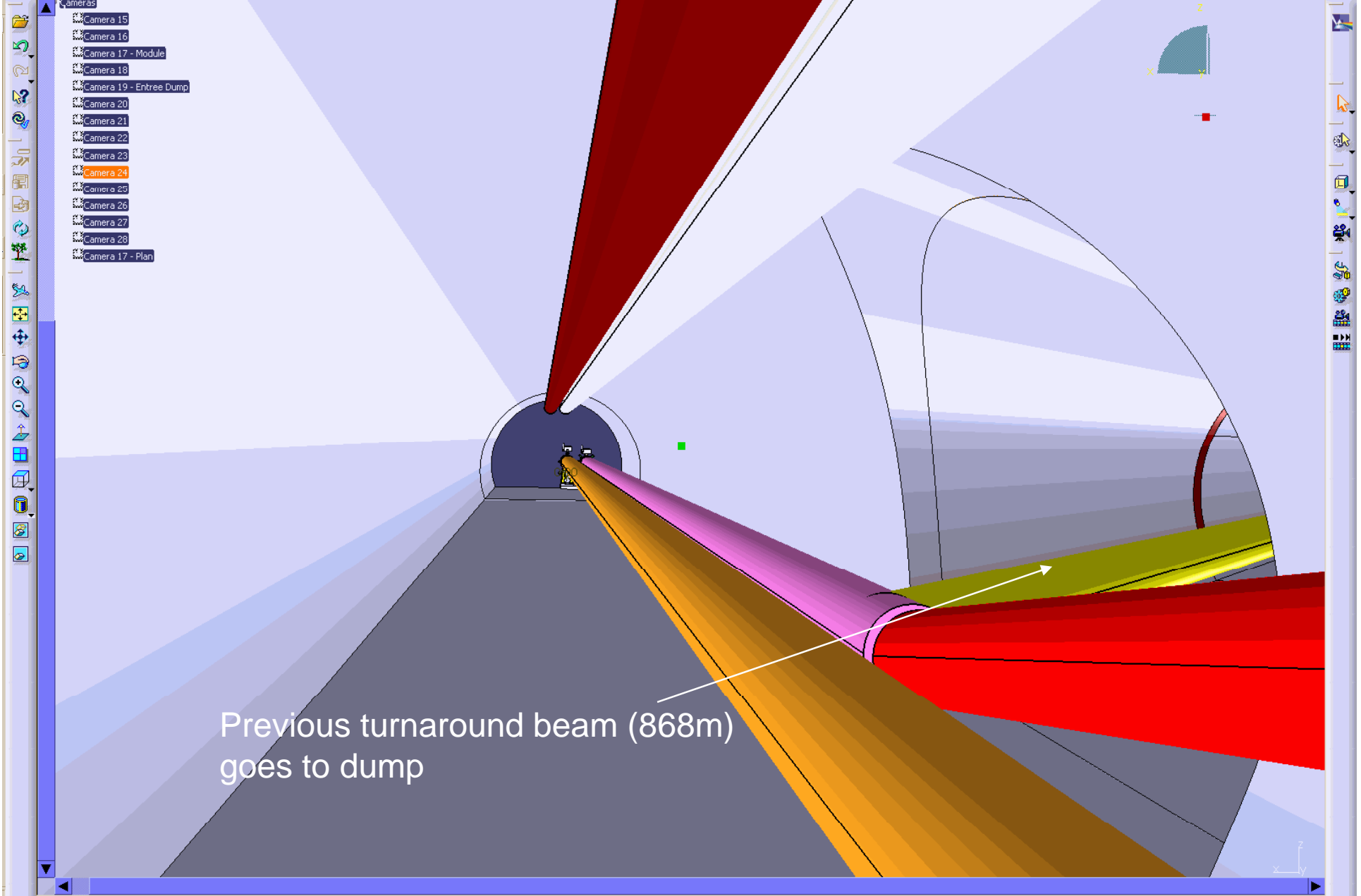

- Cameras
- Camera 15
- Camera 16
- Camera 17 - Module
- Camera 18
- Camera 19 - Entree Dump
- Camera 20
- Camera 21
- Camera 22
- Camera 23
- Camera 24
- Camera 25
- Camera 26
- Camera 27
- Camera 28
- Camera 17 - Plan

Previous turnaround beam (868m)
goes to dump

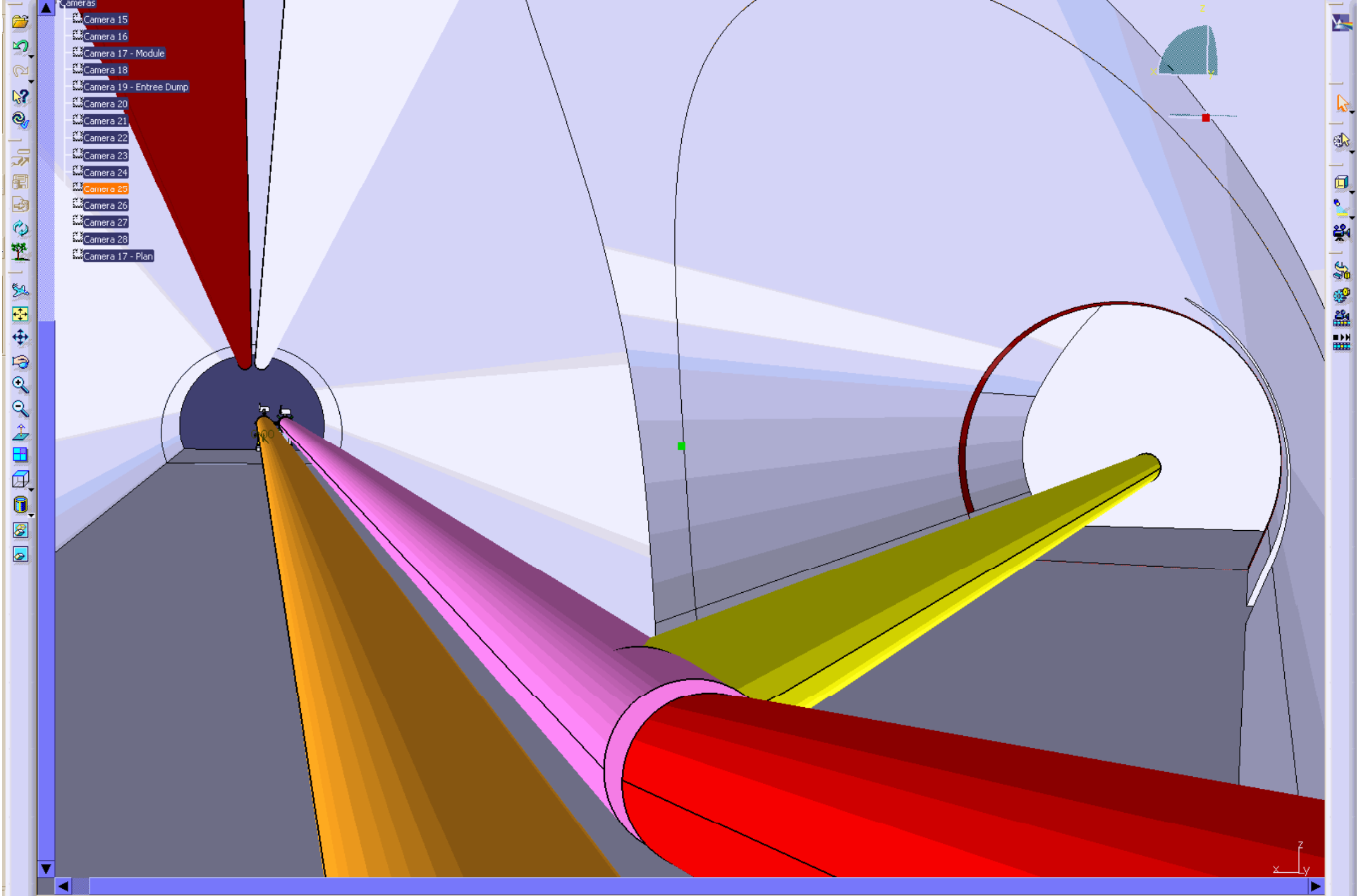

- Cameras
- Camera 15
- Camera 16
- Camera 17 - Module
- Camera 18
- Camera 19 - Entree Dump
- Camera 20
- Camera 21
- Camera 22
- Camera 23
- Camera 24
- Camera 25
- Camera 26
- Camera 27
- Camera 28
- Camera 17 - Plan

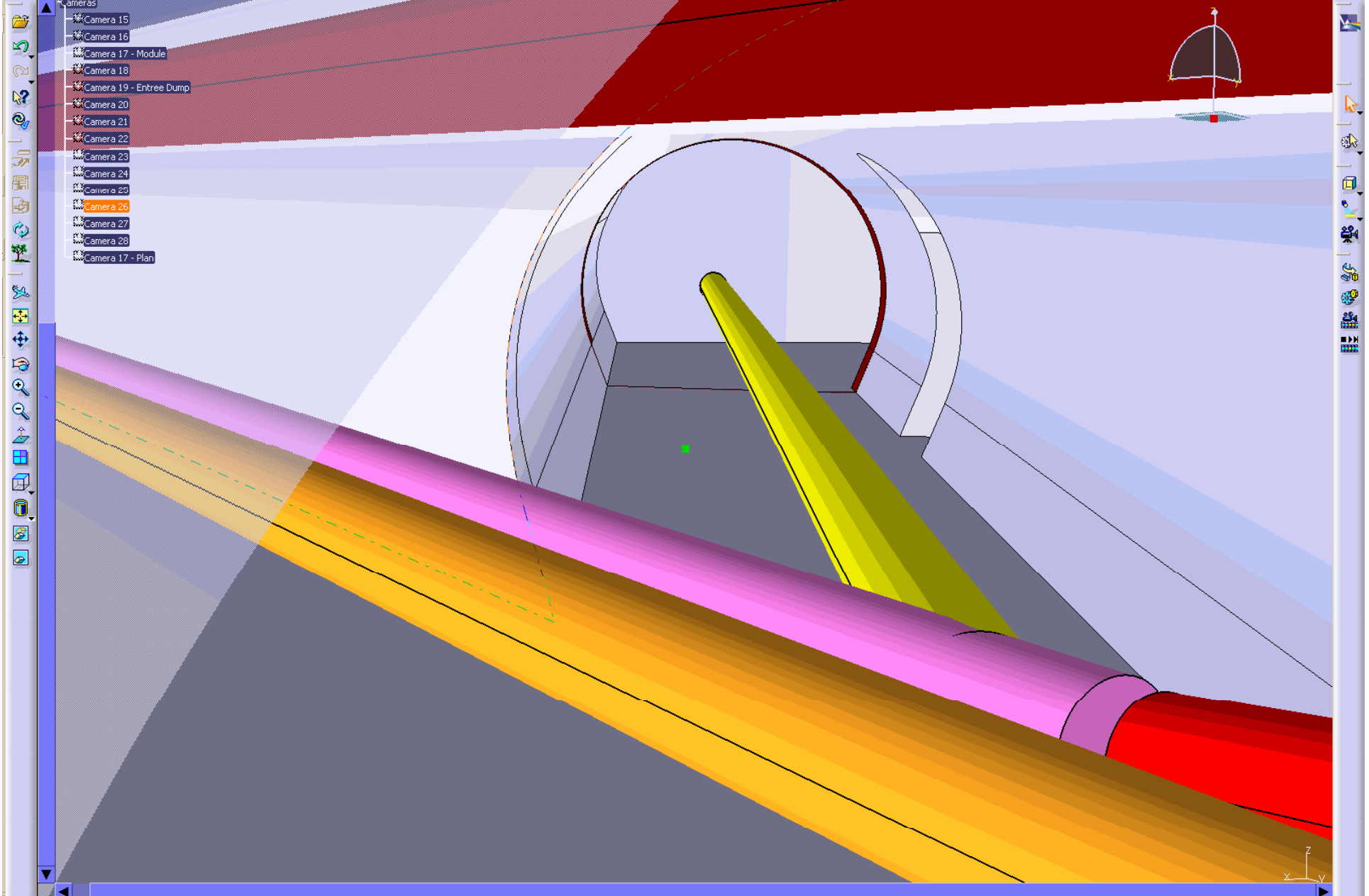

- Cameras
- Camera 15
- Camera 16
- Camera 17 - Module
- Camera 18
- Camera 19 - Entree Dump
- Camera 20
- Camera 21
- Camera 22
- Camera 23
- Camera 24
- Camera 25
- Camera 26
- Camera 27
- Camera 28
- Camera 17 - Plan

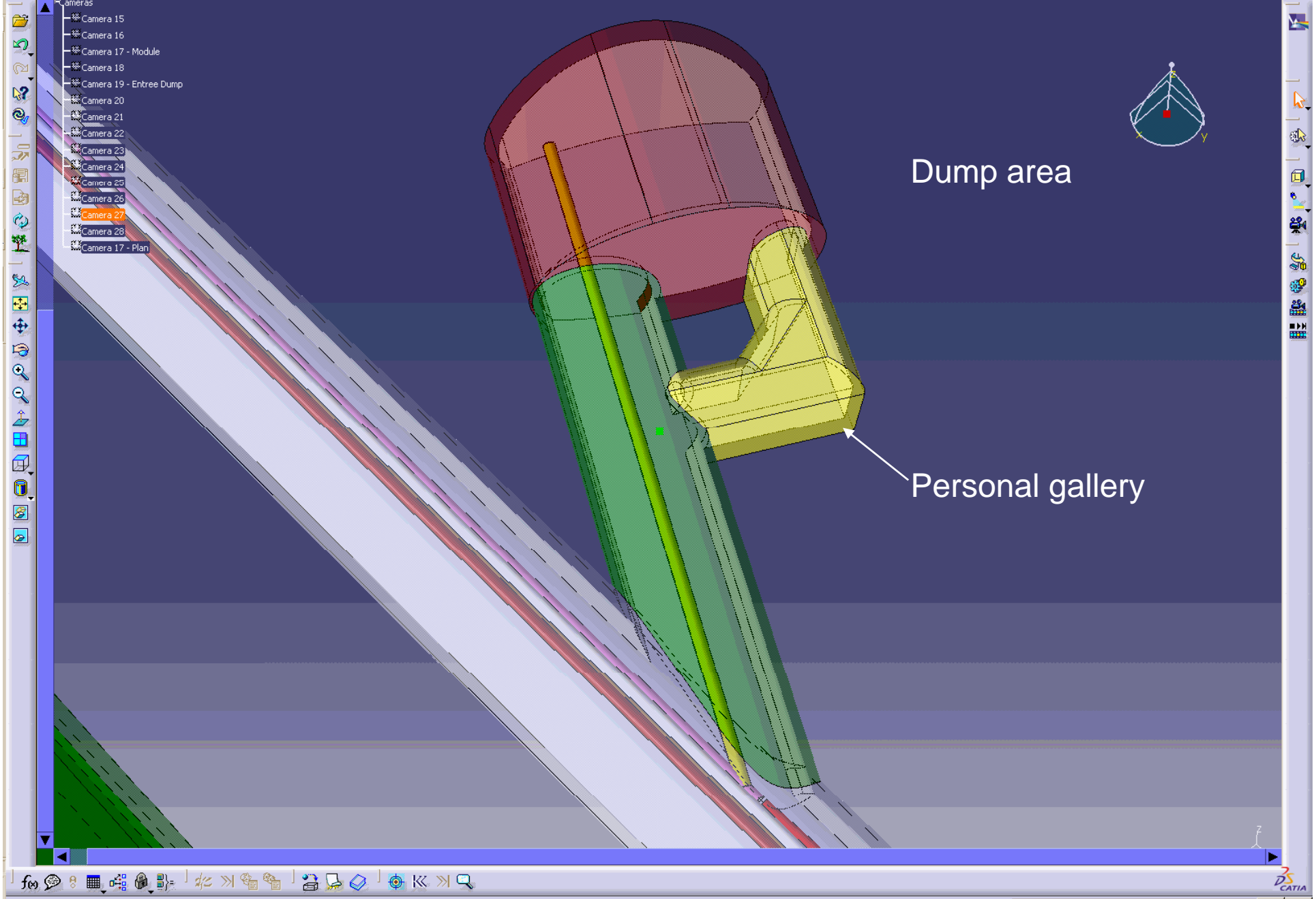

- Cameras
- Camera 15
- Camera 16
- Camera 17 - Module
- Camera 18
- Camera 19 - Entree Dump
- Camera 20
- Camera 21
- Camera 22
- Camera 23
- Camera 24
- Camera 25
- Camera 26
- Camera 27
- Camera 28
- Camera 17 - Plan

Dump area

Personal gallery

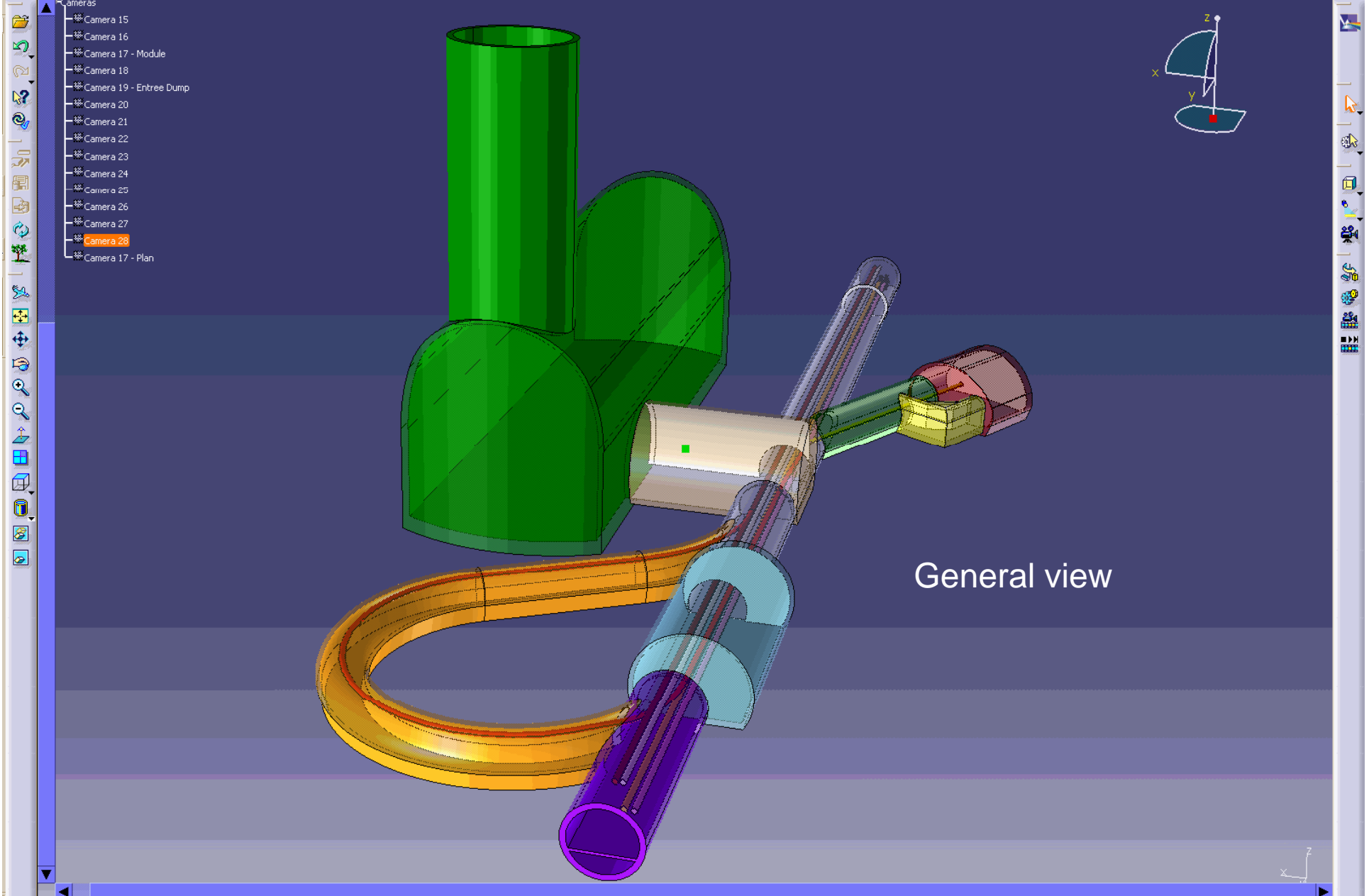

- Cameras
- Camera 15
- Camera 16
- Camera 17 - Module
- Camera 18
- Camera 19 - Entree Dump
- Camera 20
- Camera 21
- Camera 22
- Camera 23
- Camera 24
- Camera 25
- Camera 26
- Camera 27
- Camera 28
- Camera 17 - Plan

- Cameras
- Camera 15
- Camera 16
- Camera 17 - Module
- Camera 18
- Camera 19 - Entree Dump
- Camera 20
- Camera 21
- Camera 22
- Camera 23
- Camera 24
- Camera 25
- Camera 26
- Camera 27
- Camera 28
- Camera 17 - Plan

Layout view

