



Electrical Installation

CM39

Andy Gallagher & Ian Mullacrane



Science & Technology
Facilities Council



Contents

- Rack Room 2
 - Electrical Distribution
 - UPS System
 - Network
 - Cooling water for SS energy absorbers
- SS & FC Magnet Connection Boxes
- Compressor installation
- Remaining rack build
 - Vacuum rack & compressor controls
 - Diffuser and Tracker Control rack
 - EMR Rack



Rack Room 2 - Equipment Layout

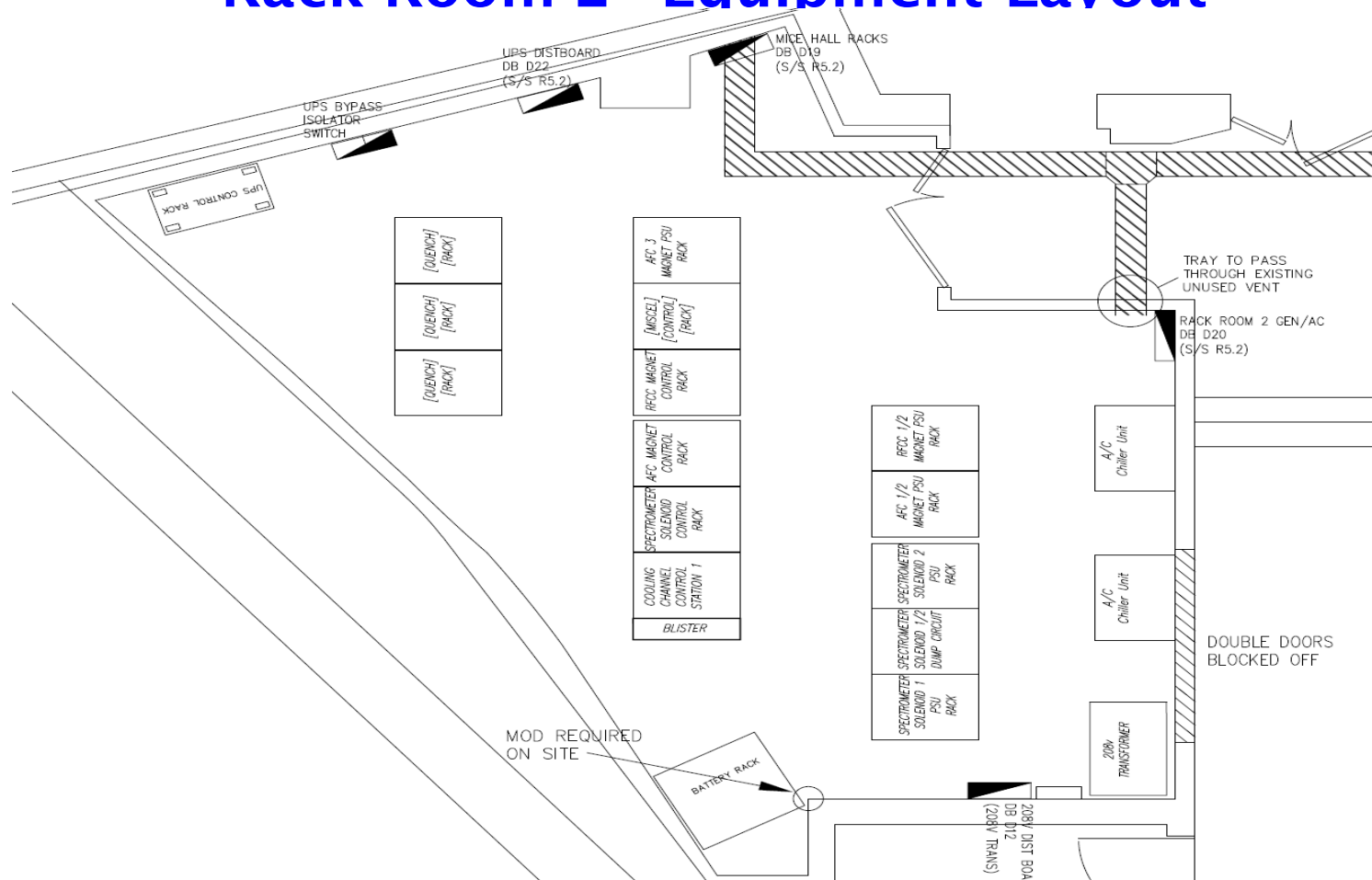

- Allocation and position of racks and equipment for Step IV agreed and finalised.
- FC Quench Detection Systems – to be installed in RR2.
- Room complete, all distribution boards installed, UPS & Battery Rack installed, Air Conditioning installed.



Rack Room 2 – Step IV Equipment Layout

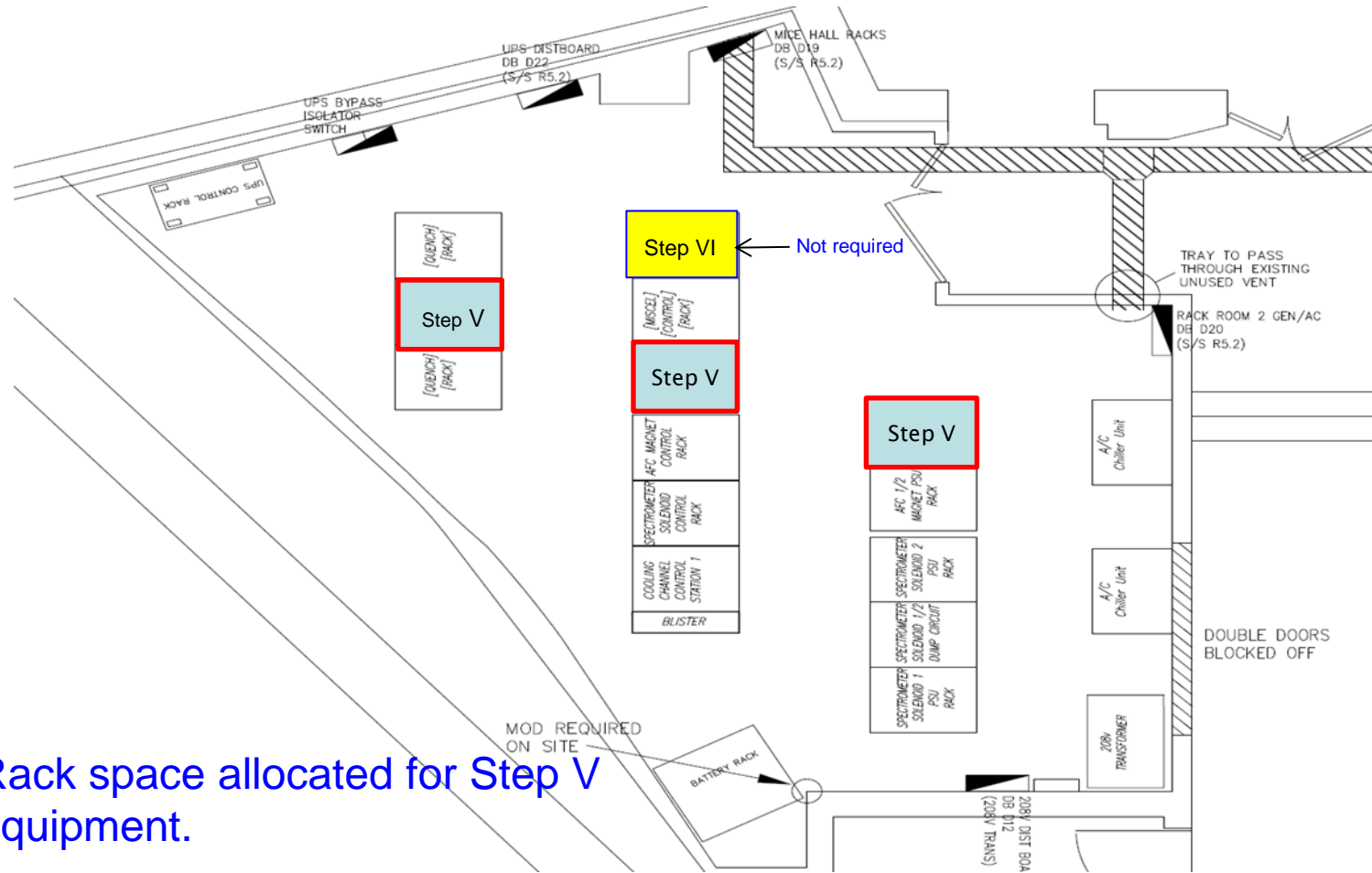

- Rack space allocated for Step V equipment.
- 1 Rack space available (no Step VI)



Rack Room 2 - Electrical Distribution



REFERENCE DRAWINGS
DRAWING LIST 204/7000
204/7001 - 204/7002 DISTRIBUTION BOARD LAYOUTS

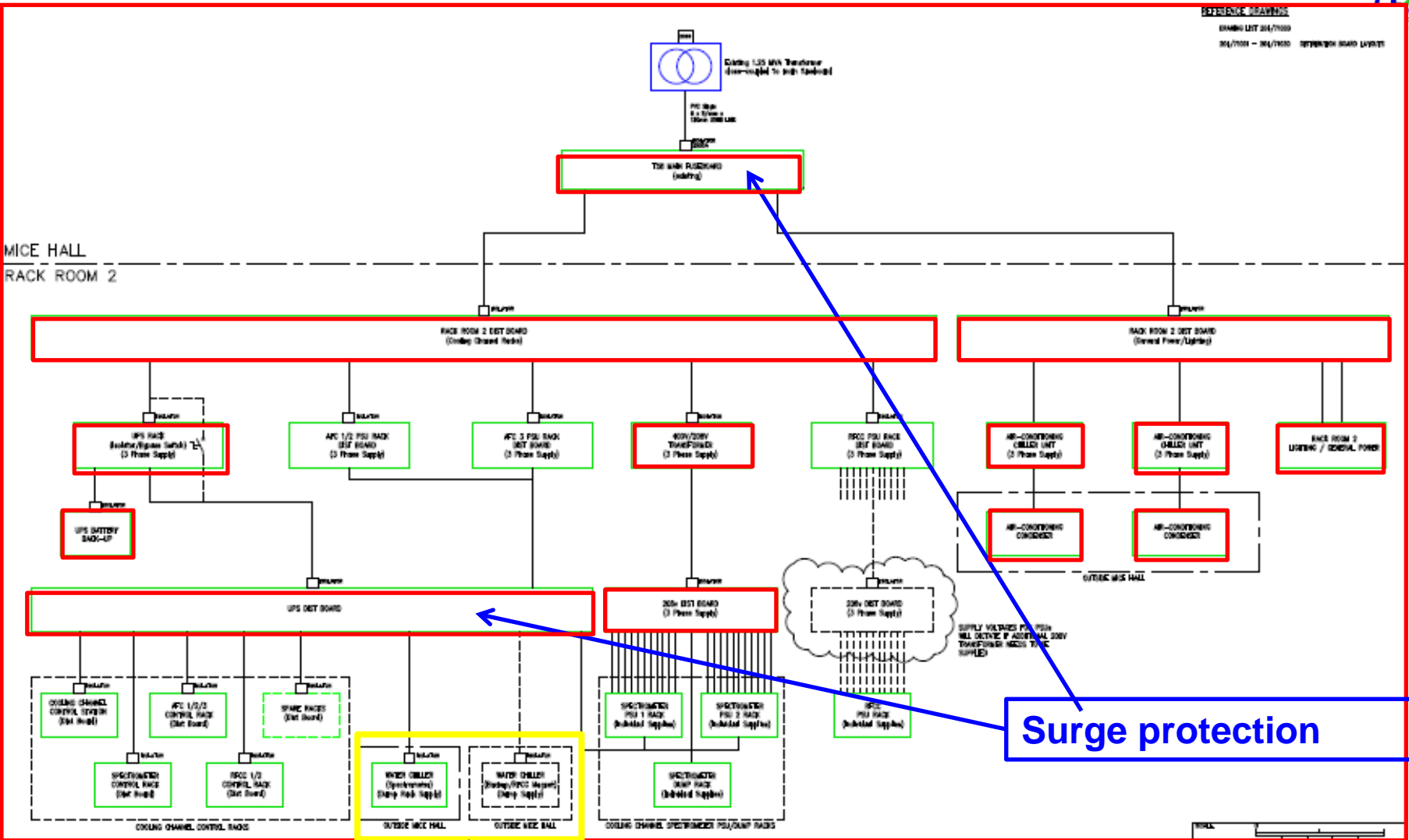

Surge protection

Chillers no longer required

Rack Room 2 - UPS

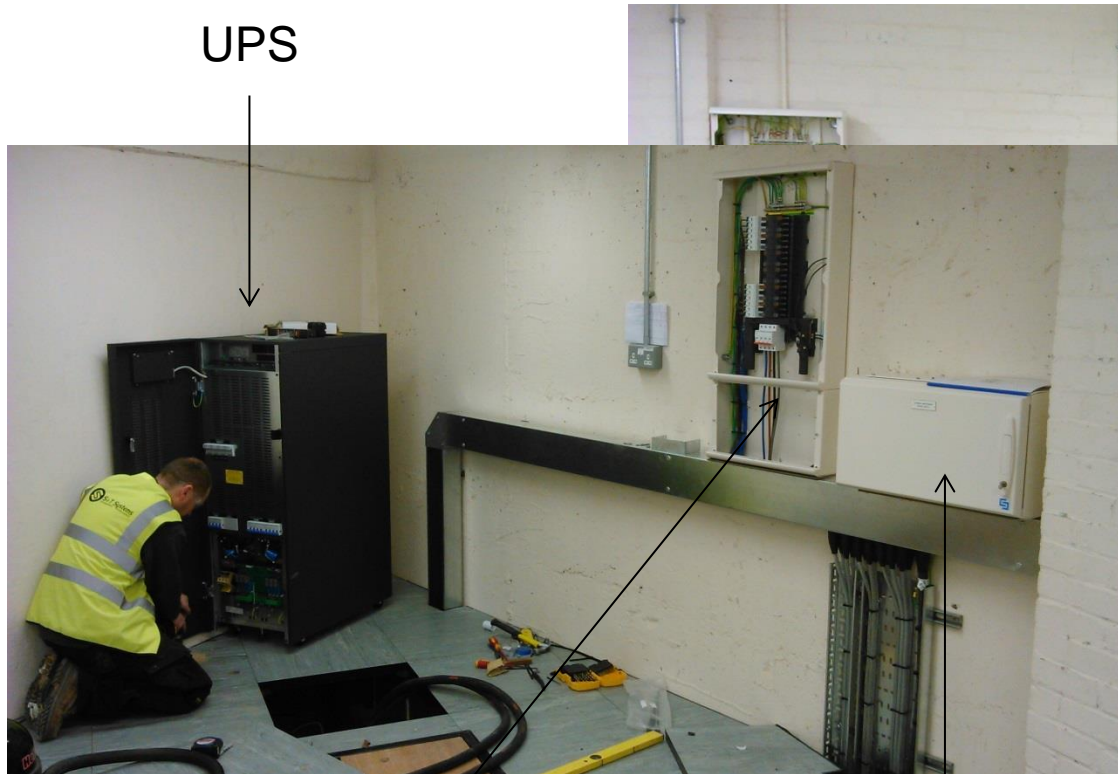

UPS

UPS Distribution Board
to include surge
protection.

UPS By-pass
switch



Battery Pack



Rack Room 2 – UPS Inverter and Batteries



UPS for Critical Loads

Riello Multi Sentry UPS –
3 Phase - Double Conversion Technology

As the cooling water will be supplied from the ISIS system we no longer require total >1hour autonomy. Some spare capacity available.

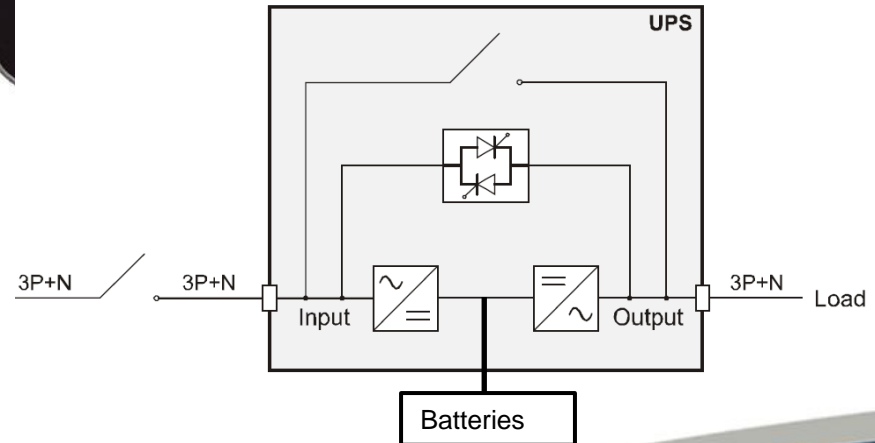
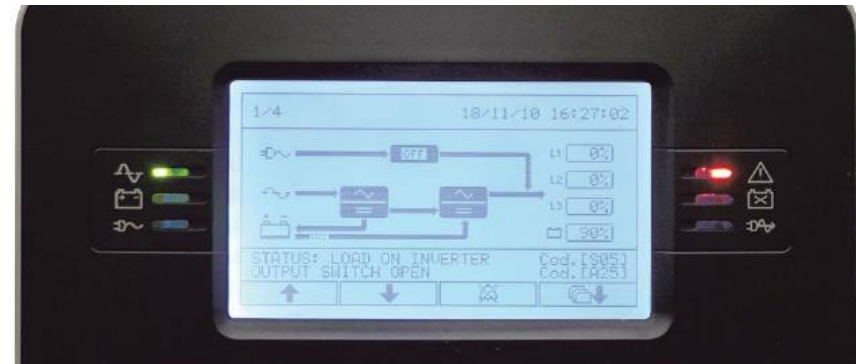

Rack Room 2 - Network



- Existing network cables to be re-used
- 24-port Network switch with 100Base-FX uplink allocated in Control Rack
- UPS & Air Conditioning can be monitored via network if required.
- Wireless router could easily be installed in RR2



First 2 Racks Delivered From DL -

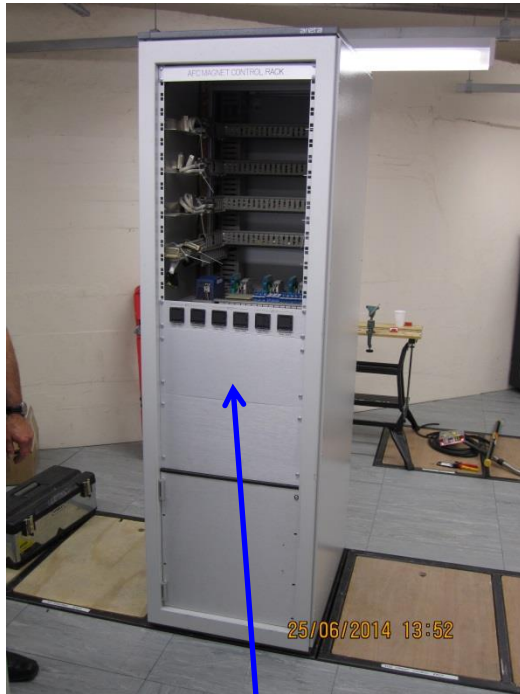

AFC 1/2 Control Rack –
Instrumentation delivered by
August.

AFC 1/2 Power Supply Rack

Cooling Water For Energy Absorbers

- It has been proposed to utilise the ISIS water cooling system
- The ISIS system has sufficient capacity.
- Sufficient cooling in the system to cope with load in the event of a power failure.
- Water flow and temperature interlocks – control philosophy to be agreed.

Magnet Termination Boxes

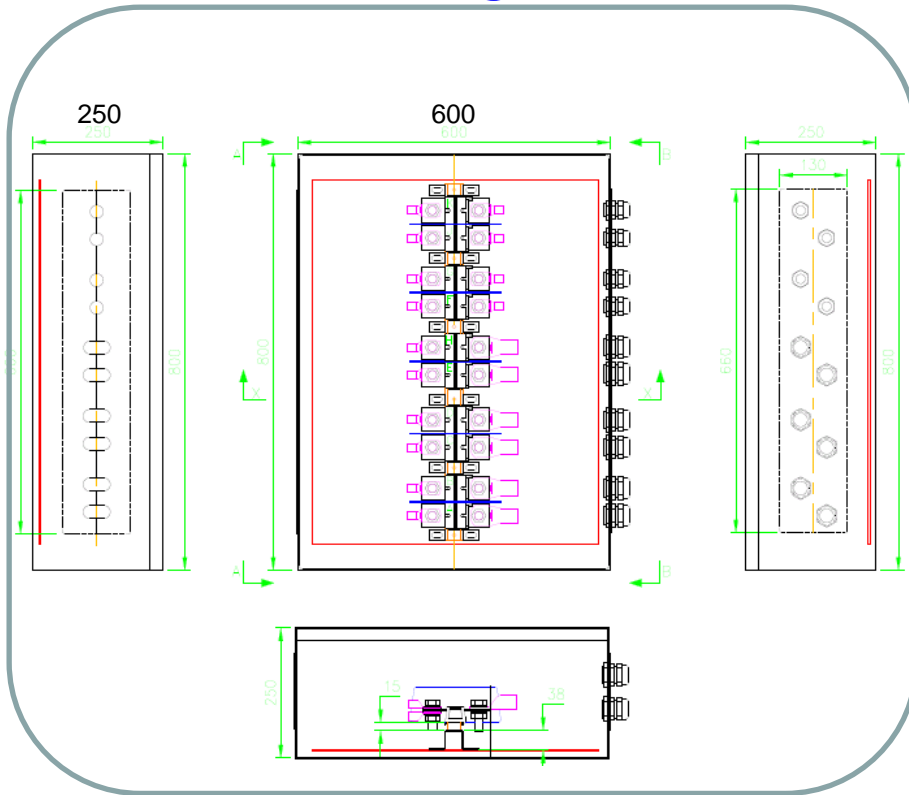

Spectrometer 1 & 2

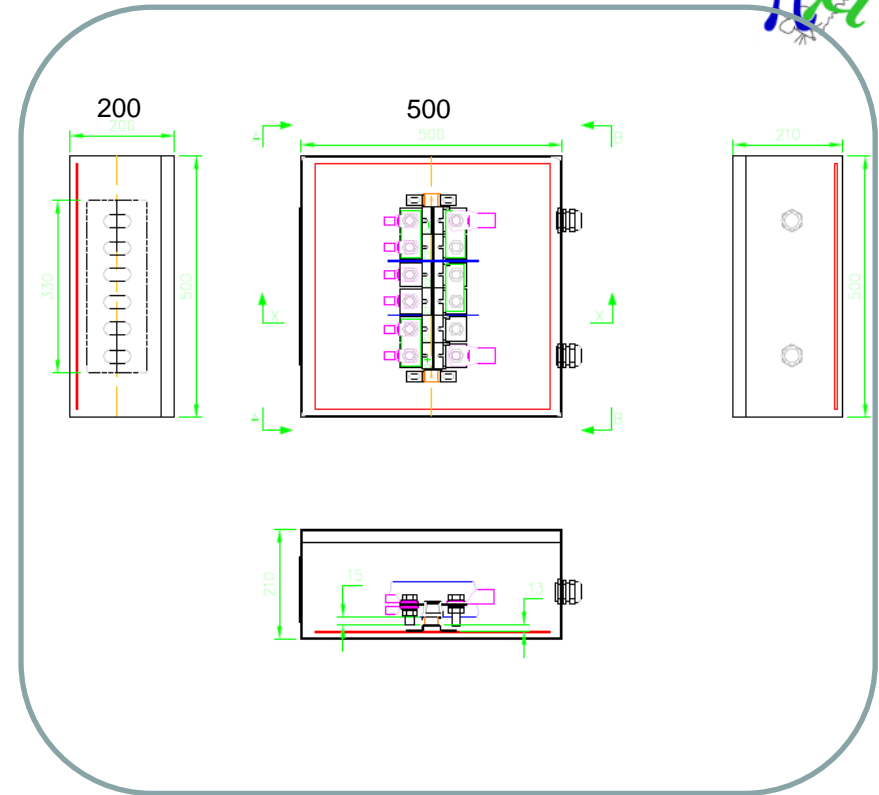

FC 1 & 2

Magnet Termination Boxes – South Mezzanine

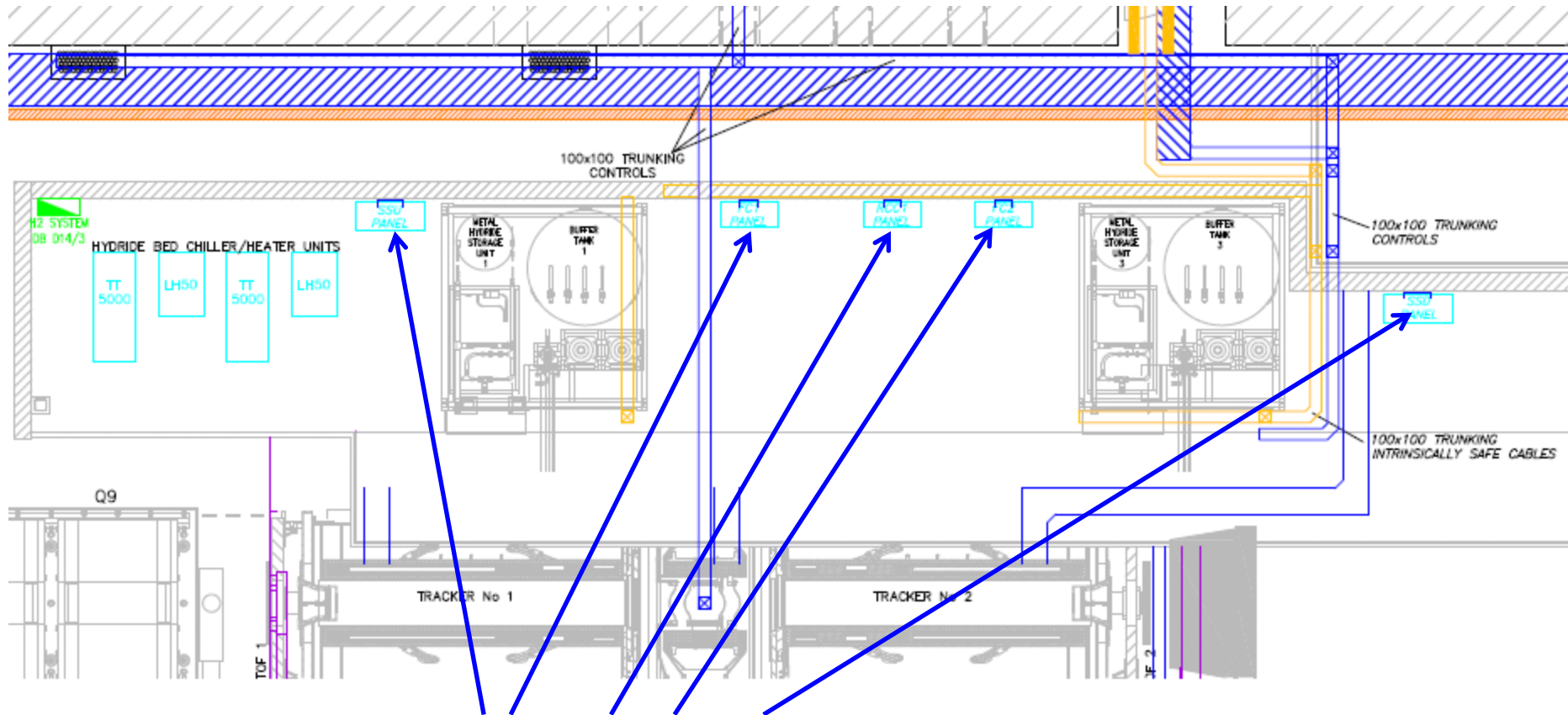

Termination Boxes spaced appropriately along cooling channel



Compressor installation

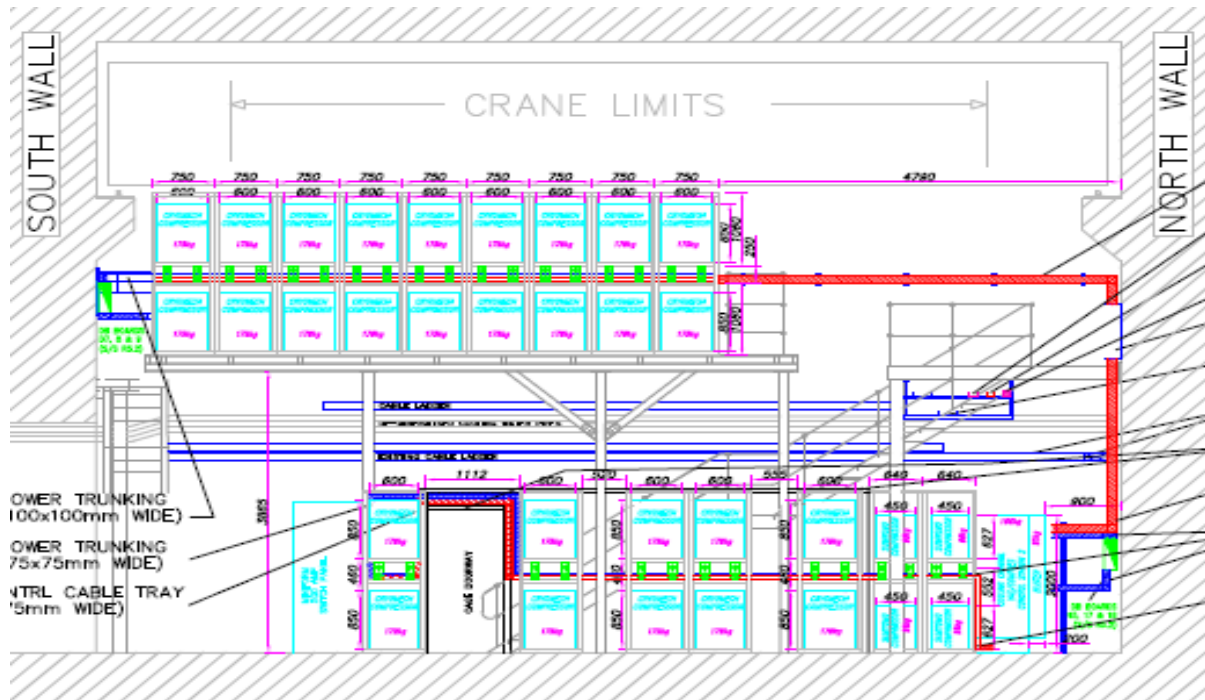

- Power Distribution Boards in place.
- Require Compressor stands to be located to allow power & controls wiring to be installed.

Remaining rack builds.



- SS Downstream – Basic rack build complete – waiting for equipment from USA.
- Absorber rack – upstream complete, downstream waiting for equipment from USA.
- Vacuum control rack – basic rack complete – design work underway.

- EMR rack – All equipment to be re-located in a new 47u rack. Design agreed.
- 2 Quench Detection racks to be designed & built.
- Diffuser & Tracker rack 2. Design complete.
- Vacuum Rack – design underway.

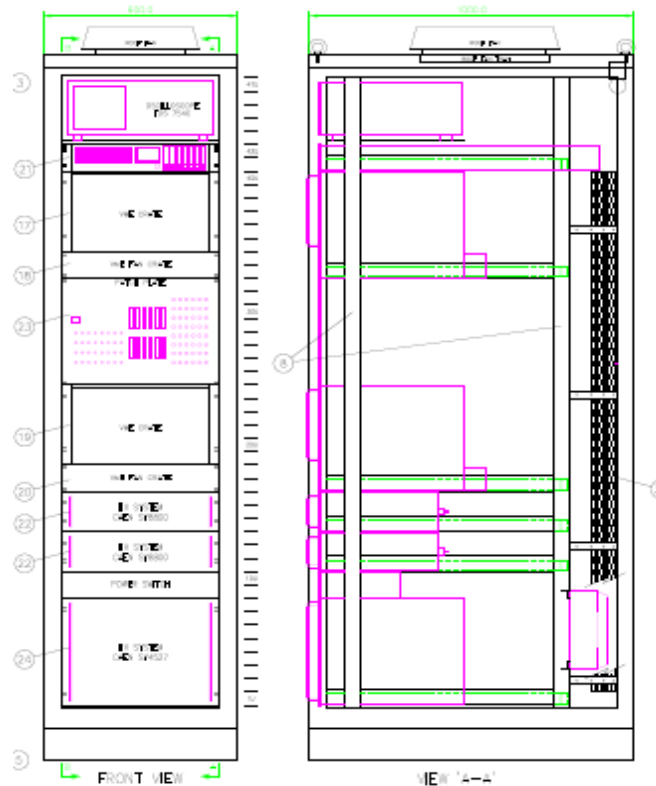

Spectrometer Solenoid Energy Absorber Rack

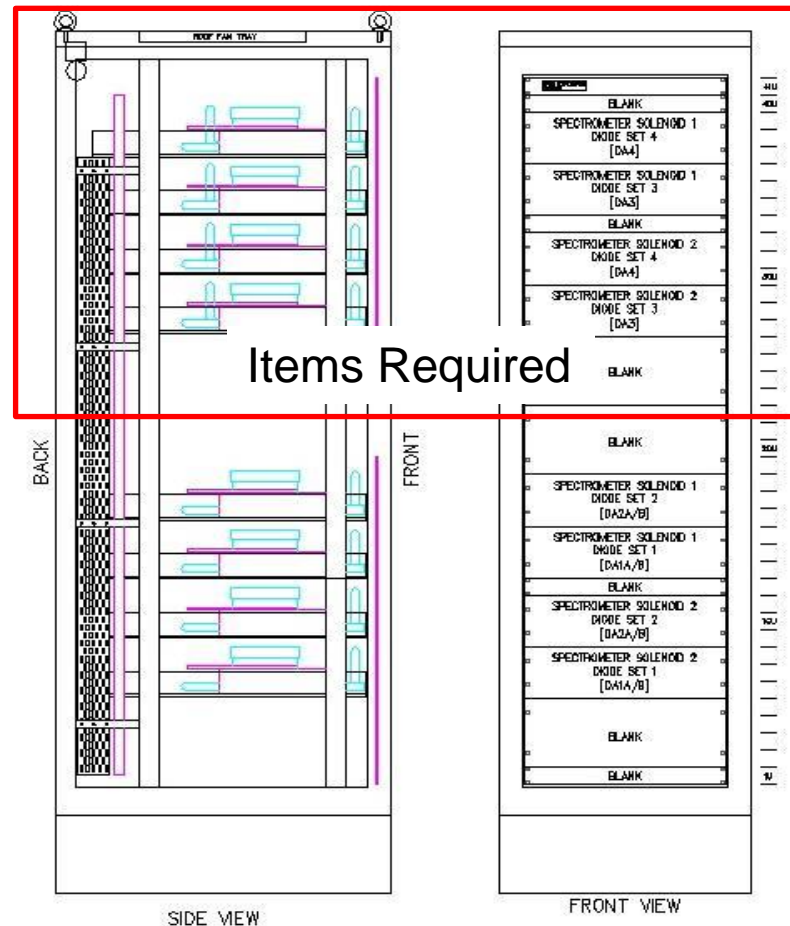

Energy Absorber Rack-Rear with and without DC Cables

- Upstream SS energy absorber tests complete.
- Cooling water circuits have been modified and flow indication added.
- Downstream SS energy absorbers due for delivery late July 2014.

Quench Detection & Protection Racks

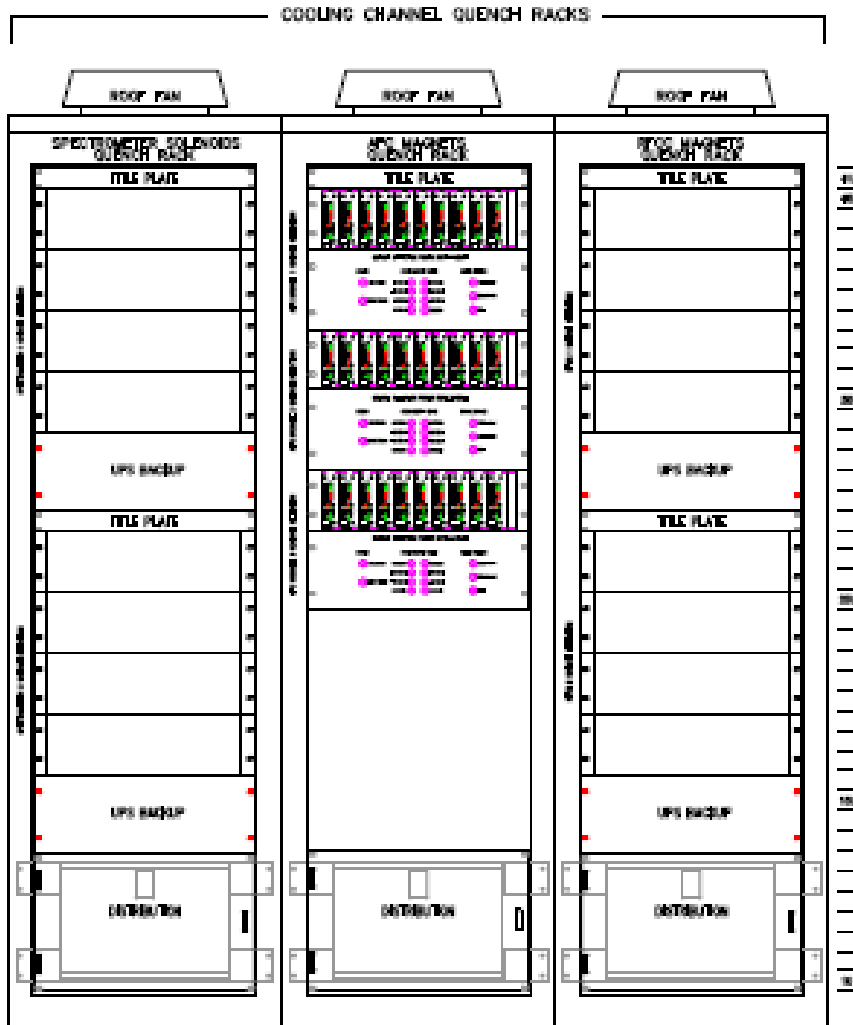

SS QD / QP
System rack

FC QD / QP
System rack

RFCC QD / QP
System rack

- The location of the FC QD systems is agreed.
- Reliable operation with 40m voltage tap cable lengths has been confirmed.
- Two FC QD systems have been assembled and tested.
- One system is currently being used for training the FCs.
- The location for SS QD systems to be confirmed.
- A 3rd SS QD system is to be assembled, tested and installed before Nov 2014.



Focus Coil & Spectrometer Solenoid PSU Racks



Cooling Channel PSU Racks - Step IV

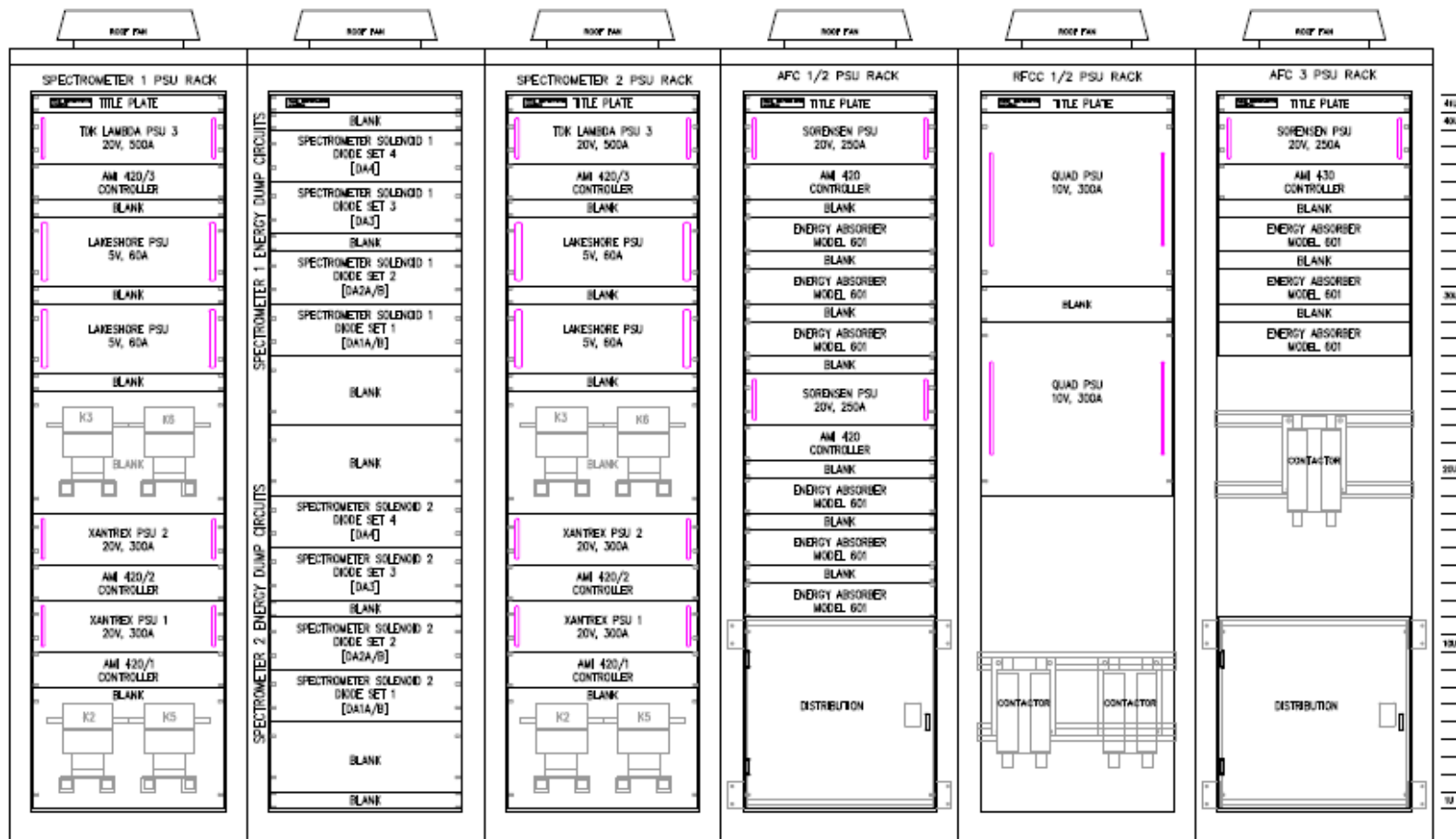

- These 4 racks are all designed.
- Assembly is completed apart from SS#2 PSU rack.

Diffuser and Tracker Control Rack



Cooling Chanel Control Racks for Step IV

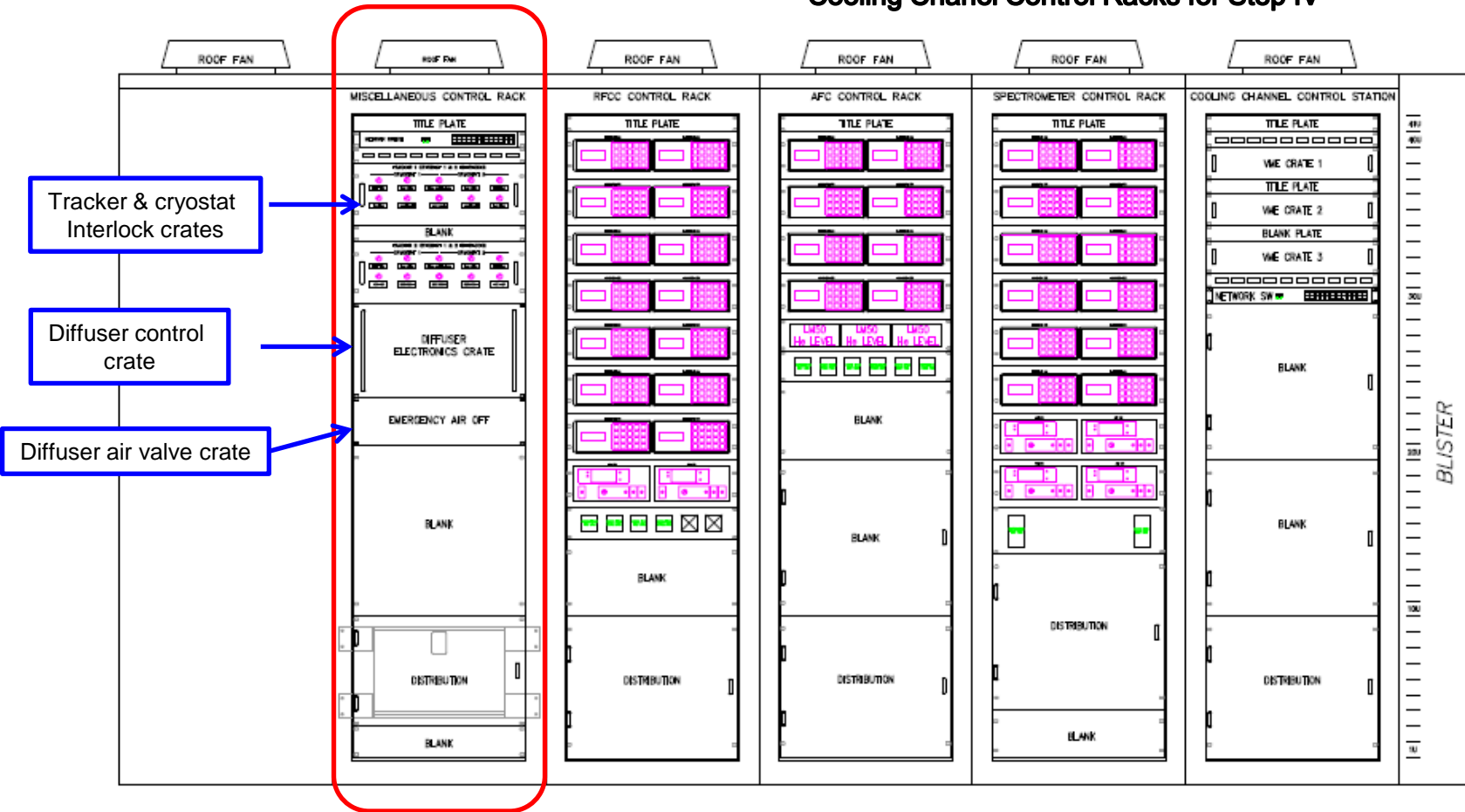

- The rack design is complete.
- The rack will be assembled ready for population with equipment by September 2014.



Compressor & Vacuum Control Rack



COMP/VAC CONTROL STATION

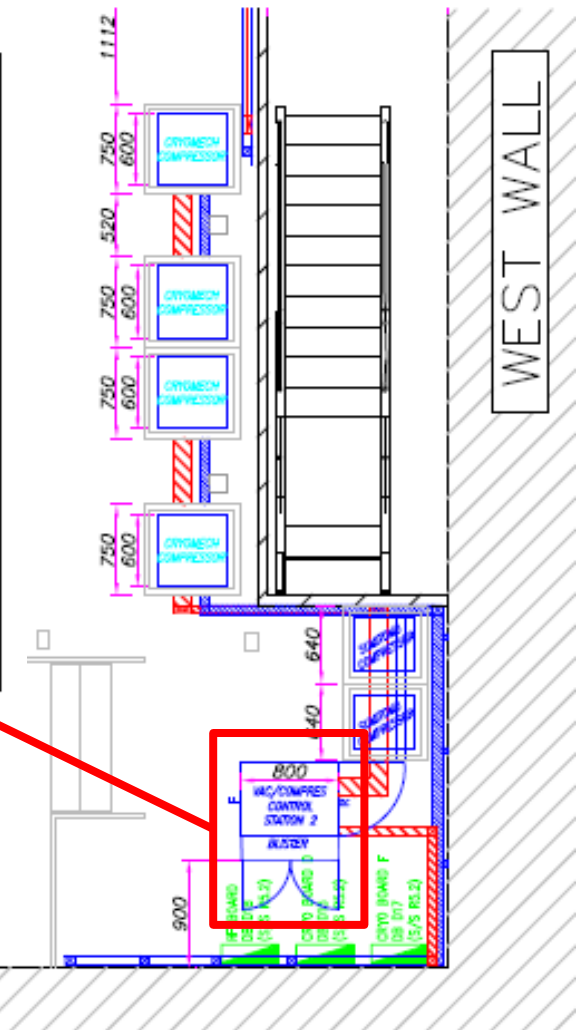
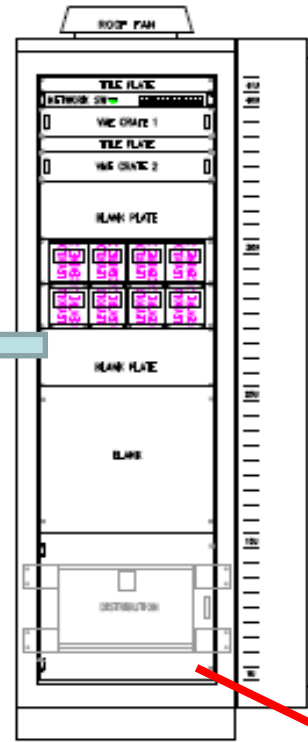

- The control system requirements for the compressors are agreed and the rack physically assembled.
- Vacuum flow diagram agreed and design is underway.



Questions?

CM39

A Gallagher & Ian Mullacrane

Acknowledgements

Chris White

Trevor Hartnett

John Webb

Steve Griffiths

