

# FCC Horizon 2020 Design Study Proposal



Daniel Schulte for the FCC team

Preparatory Collaboration Board Meeting, September 2014

# *EuroCirCol Objectives*

Design studies should address all key questions concerning the technical, legal and financial feasibility of new or upgraded facilities, leading to a 'conceptual design report' showing the maturity of the concept and forming the basis for identifying and constructing the next generation of Europe's and the world's leading research infrastructures.

For 100 TeV energy frontier hadron collider:

- Conceive collider conceptual design
- Define collider infrastructure
- Assess feasibility of accelerator key elements
- Draft implementation scenario



# EuroCirCol Consortium

Short Name	Country
<b>CERN</b>	IEIO
<b>TUT</b>	Finland
<b>CEA</b>	France
<b>CNRS</b>	France
<b>KIT</b>	Germany
<b>TUD</b>	Germany
<b>INFN</b>	Italy
<b>UT</b>	Netherlands
<b>ALBA</b>	Spain
<b>CIEMAT</b>	Spain
<b>STFC</b>	United Kingdom
<b>UNILIV</b>	United Kingdom
<b>UOXF</b>	United Kingdom
<b>KEK</b>	Japan
<b>EPFL</b>	Switzerland
<b>UNIGE</b>	Switzerland

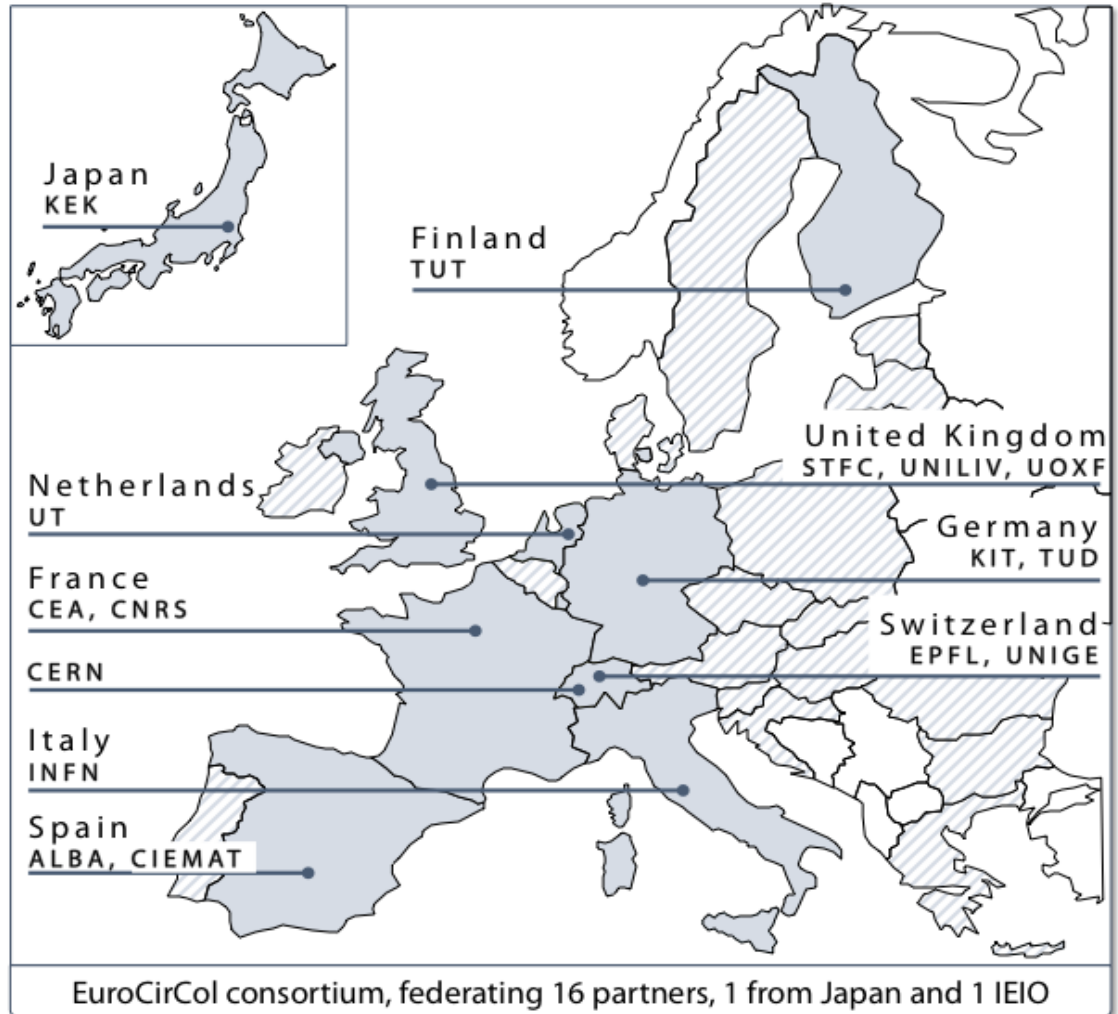

# Associated Partners

Short Name	Country	Contribution
NHFML /FSU	USA	Explore potential to double $J_c$ of superconducting $Nb_3Sn$ at 16 T. Propose improvements in strand architecture and reaction optimization. Material research in BSCCO-2212 as alternative to A15 and high field magnet technology using HTS materials.
BNL	USA	Participate in the study of magnet coil design concepts (common coils, racetrack) and in the engineering for a US-based 16 T model. Develop YBCO HTS technology for high field inserts for 20 T option or for use in high heat load/radiation cases.
FNAL	USA	Participate in the study of magnet coil design concepts (cos-theta, collars) and in the engineering for a US-based 16 T model. Prepare tooling for model construction. Develop BSCCO-2212 HTS magnet technology for high field inserts for 20 T option.
LBNL	USA	Participate in the study of magnet coil design concepts (blocks, canted-cosinus-theta) and in the engineering for a US-based 16 T model. Develop BSCCO-2212 HTS magnet technology for high field inserts.



# Schedule and Budget

- The study will last four years
- Total budget is about 10M€ (1509 person months)
- Total EC contribution is 2.999M€
- Partners receive roughly the same from the EC as their own contribution
- **EPFL** and **UNIGE** are beneficiaries, not requesting EC funding. Funding will be ensured by the Swiss State Secretariat for Research and Education
- In line with H2020 participation rules, **KEK** joins as beneficiary, not requesting any EC funding and comes up for its committed resources.
- CERN will request nearly no contribution but provides about 1/3 of project



# *Rational for EuroCirCol Scope*

- Had to choose a sub-set of FCC R&D for EuroCirCol to match a 10M€ budget
  - Need a coherent activity “addressing all the key questions”
  - Had to make sure that collaborators will profit from EU contribution
- ⇒ Limited study to FCC-hh collider and its technology
  - Explicitly mentioned as high priority in the European strategy for particle physics
- ⇒ Have chosen the most critical FCC-hh technical cost and performance drivers as part of EuroCirCol
  - Very interesting for collaborators
- ⇒ Much more work will be required for a CDR
- ⇒ Made a link to work outside of EuroCirCol
  - E.g. more collider ring studies, infrastructure, injectors and civil engineering



# Workpackages



Arc Design

Arc Design

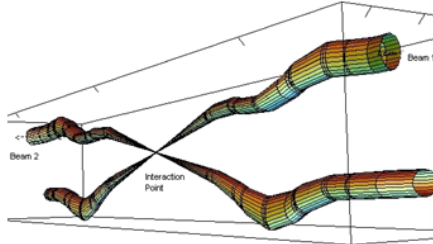

EIR Design

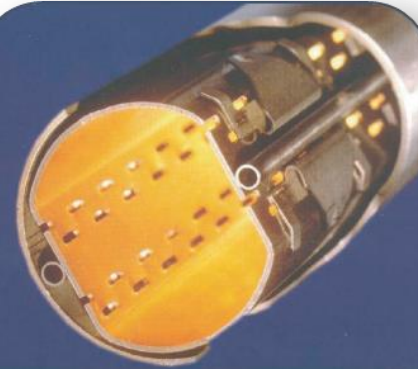

Cryo Beam Vacuum



High Field Magnet

Management and Coordination

1. Management, Coordination and Implementation
2. Arc Design and Lattice Integration
3. Experimental Insertion Design
4. Cryogenic Beam Vacuum System Conception
5. High-field Accelerator Magnet Design

# EuroCirCol Scope

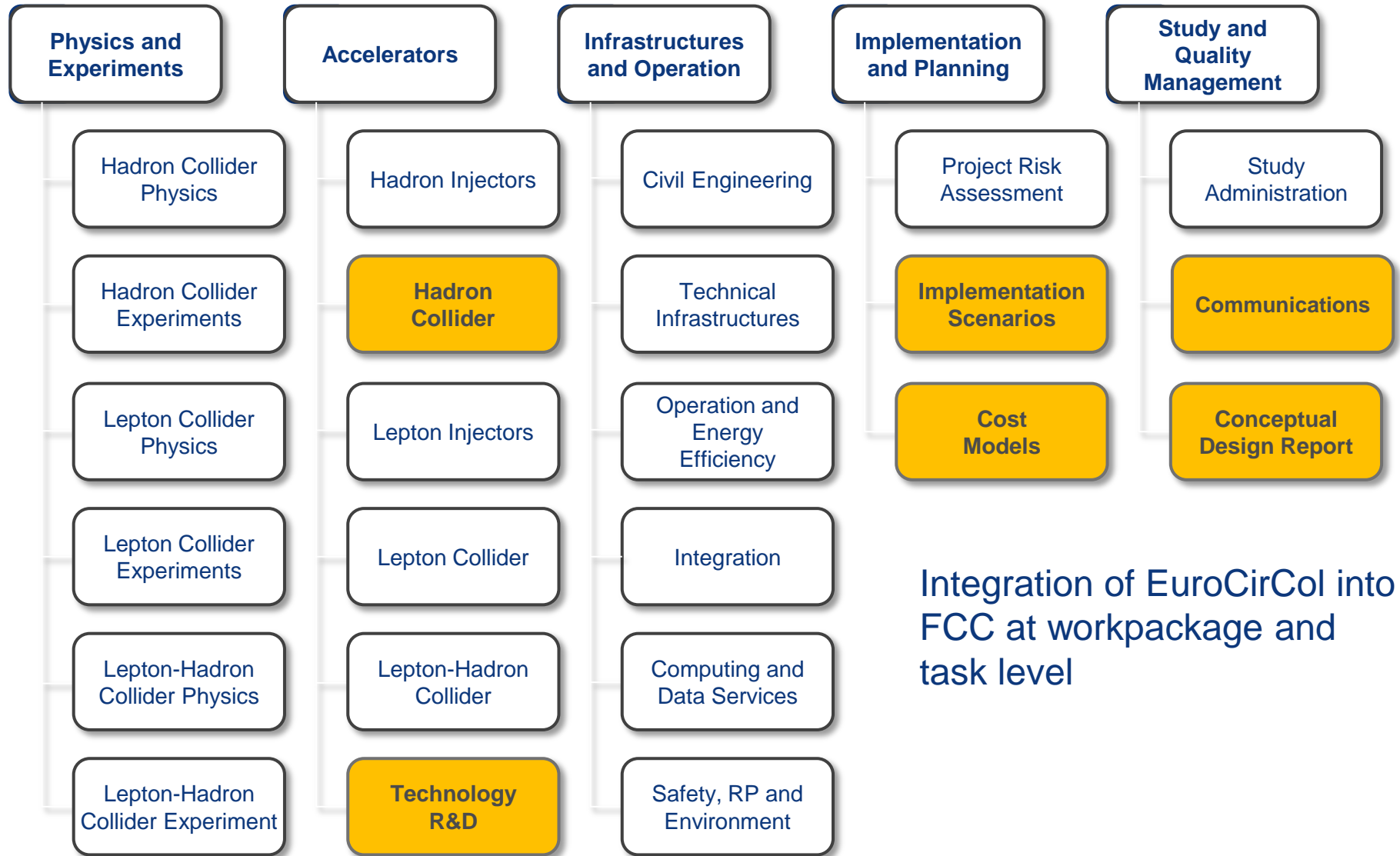

Integration of EuroCirCol into FCC at workpackage and task level



# Management, Coordination & Implementation (WP1)

1. Study management (**CERN**)
2. Quality management (**CERN**)
3. Communication, dissemination and outreach (**ULIV**, CERN)
4. Knowledge and innovation (**CERN**)
5. Coordinate technical scope (**CERN**)
  - This links to the overall FCC-hh R&D
  - Parameters and layout
6. Develop implementation and cost scenarios (**CERN**)
  - This links to the cost, site and implementation studies



# Arc Design and Lattice Integration (WP2)

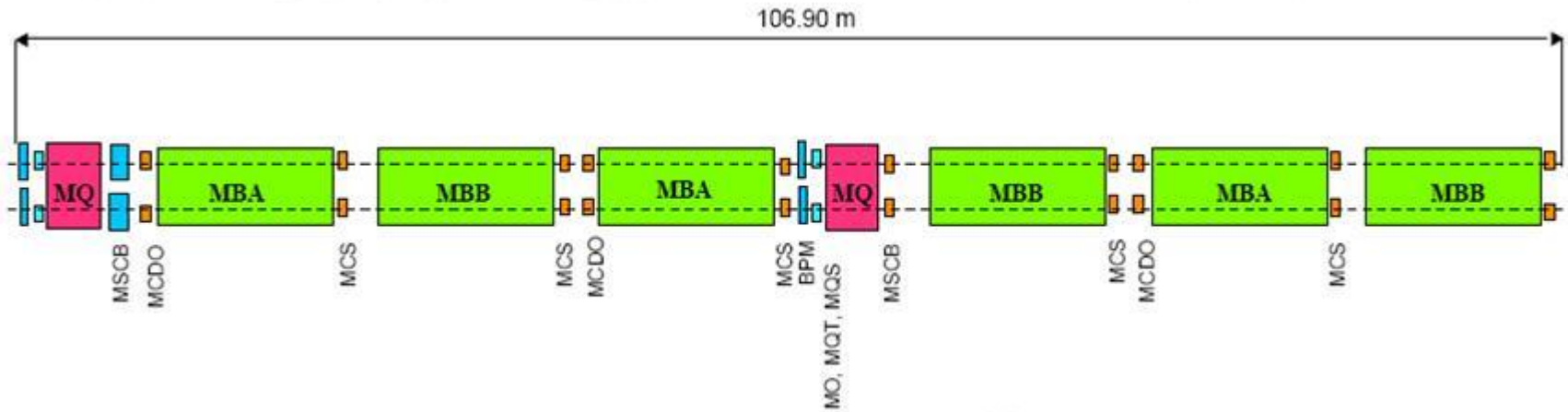

- 1) Optimised conceptual design of arc
- 2) Study and optimise dynamic aperture and magnet tolerances
- 3) Conceptual design of collimation optics
- 4) Key functional specifications for arc components

Lattice design and dynamic aperture

Beam stability

Electron cloud build-up

# *Arc Design and Lattice Integration (WP2)*

1. Coordination (**CEA**, CERN)
2. Develop optimised arc lattice (**CEA**, CERN)
3. Study dynamic aperture (**CEA**, CERN)
4. Study single beam current limitations (**TUD**, CERN)
5. Understand and control impact of electron cloud (**KEK**, CERN)
6. Develop optics concept for the collimation system (**CNRS**, CERN)

# Experimental Insertion Region Design (WP3)

- 1) Conceptual design of interaction region
- 2) Key functional specifications for components
- 3) Conceptual design of machine-detector interface
- 4) Identification of future R&D needs

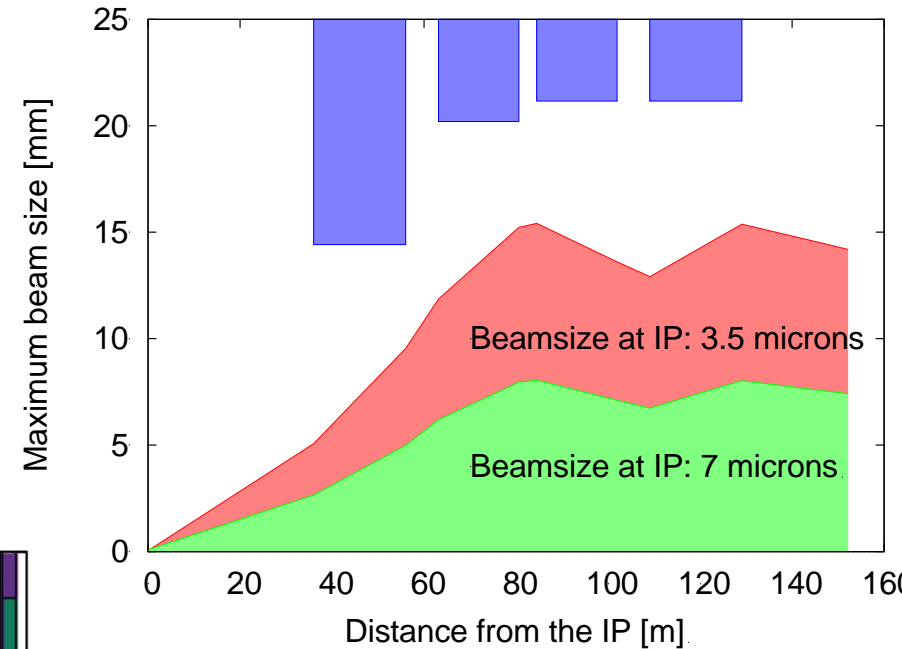
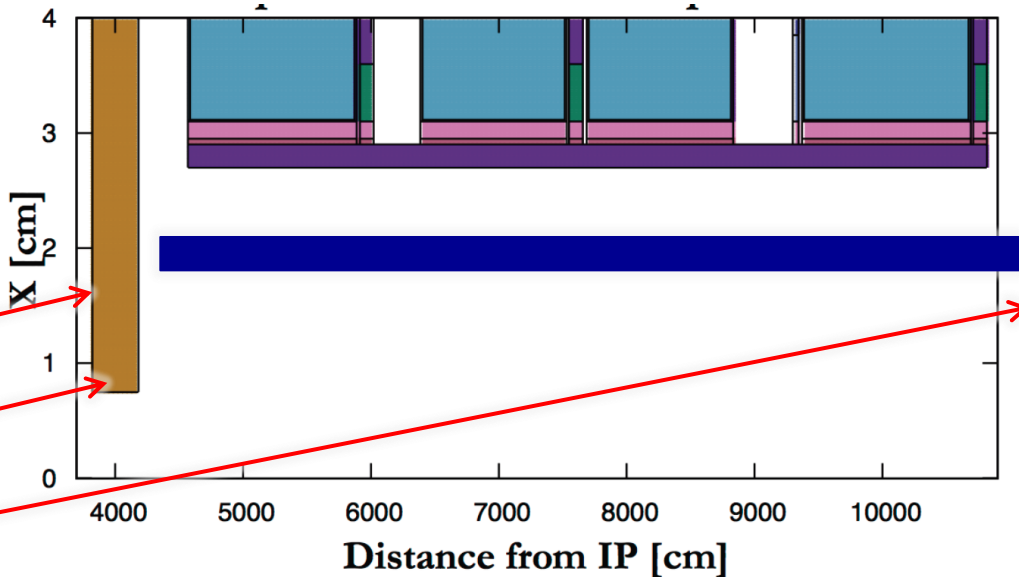

Small beta-functions  
Collision debris  
Beam-beam interaction

...

# *Experimental Insertion Region Design (WP3)*

1. Coordination (**UOXF (JAI)**, CERN)
2. Develop interaction region optics (**UOXF (JAI)**, CERN)
3. Design machine detector interface (**STFC (UMAN)**, INFN, CERN)
4. Study beam-beam interaction (**EPFL**, CERN)



# Cryogenic Beam Vacuum Conception (WP4)

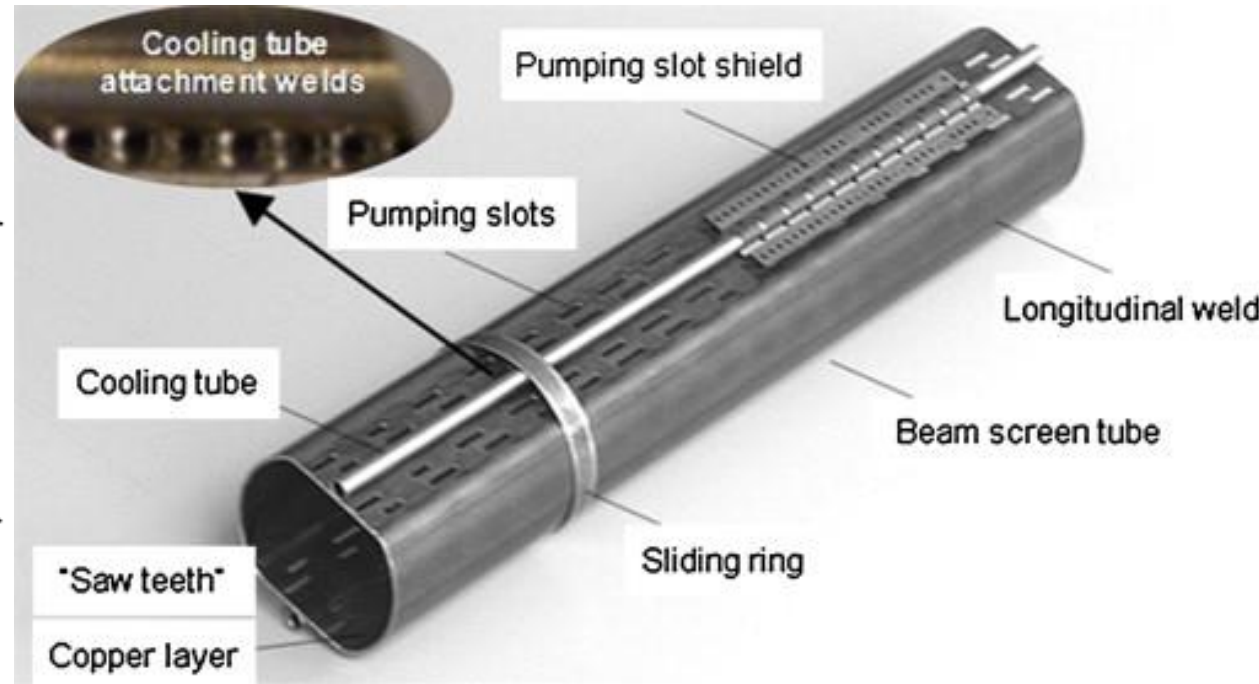
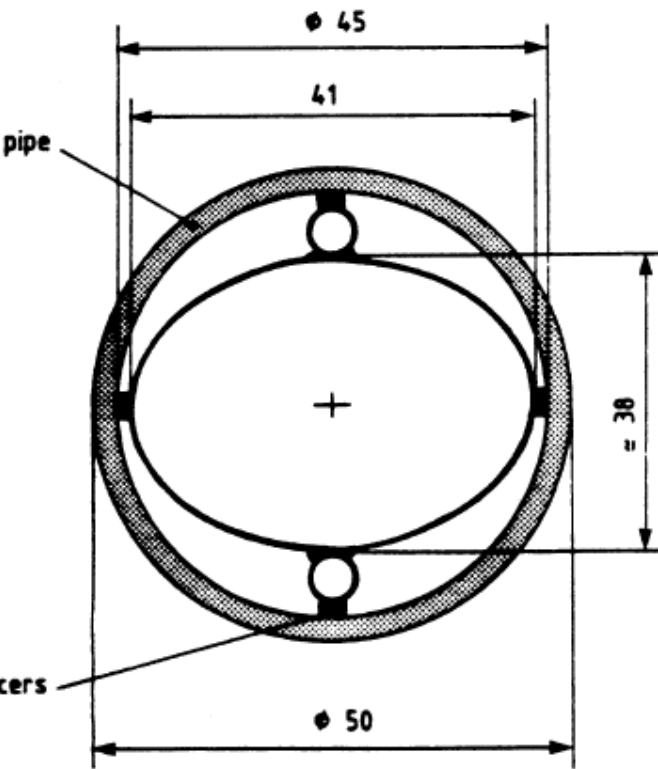

- 1) Impact of arc design on technology requirements
- 2) Overall integrated design of cryogenic beam vacuum system
- 3) Identify technology needs
- 4) Impact of synchrotron radiation on heat and electron photo-production
- 5) Novel mitigation techniques

# Cryogenic Beam Vacuum Conception (WP4)

1. Coordination (**ALBA**)
2. Study beam-induced vacuum effects (**ALBA**, CERN)
3. Mitigate beam-induced vacuum effects (**STFC**, CERN)
4. Study vacuum stability at cryogenic temperatures (**INFN**, CERN)
5. Develop conceptual design for cryogenic beam vacuum system (**CERN**, CIEMAT)
6. Measurements on cryogenic beam vacuum system prototype (**KIT**, INFN, CERN)



# High-field Accelerator Magnet Design (WP5)

Main cost driver

Field level is a challenge but many additional issues:

- Field quality
- Aperture needs
- Beam separation
- Cost
- ...

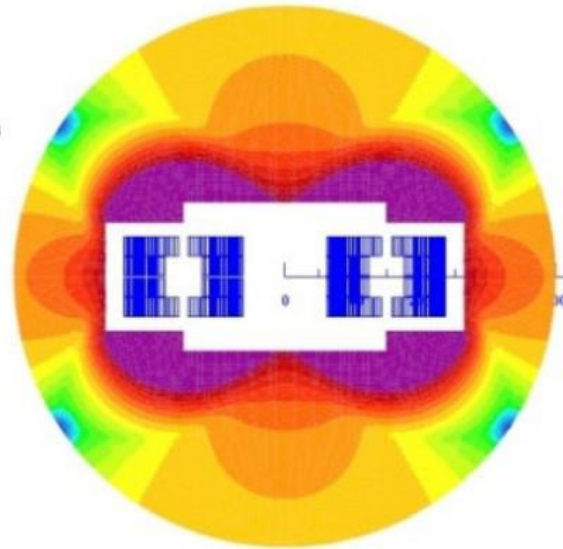

Baseline: 16T ( $\text{Nb}_3\text{Sn}$ )  
Alternative: 20T (HTS)

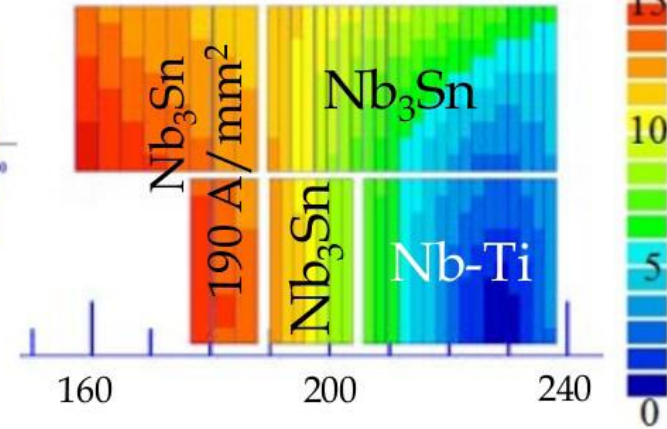

Coil sketch of a 15 T magnet with grading, E. Todesco

- 1) Explore design options for O(16T) magnets
- 2) Conceptual design for most promising ones
- 3) Calibrated cost model
- 4) Preferred option => baseline design
- 5) Engineering design of baseline



# High-field Accelerator Magnet Design (WP5)

1. Coordination (**CERN**)
2. Study accelerator dipole magnet design options (**CEA**, KEK, CERN)
3. Develop dipole magnet cost model (**CERN**, CEA, CIEMAT)
4. Develop electromagnetic design (**INFN**, CIEMAT, UT)
5. Develop mechanical engineering design (**CIEMAT**, CEA, UT, UNIGE)
6. Devise quench protection concept (**TUT**, INFN)



# Conclusion

- Preparation of EuroCirCol showed very strong interest in and support for FCC
  - Many commitments already made, more in the pipeline
  - Strong contributions of the collaboration to the study contents
  - Already some link to Asia and the US
- The proposal includes the core FCC-hh machine studies
  - Arcs, EIR, MDI, collimation, dipoles and beam pipe system
  - Need to also address other important studies
  - Need also verification of key results
  - Need global effort
- Integration with FCC at all levels to be as transparent as possible
  - Highest efficiency use of resources
- **Let us hope that we receive the funding**



# *Reserve*



	Participant Organisation Name	Abr.	Country
1	European Organisation for Nuclear Research (Coordinator)	CERN	IEIO
2	Technical University of Tampere	TUT	Finland
3	Commissariat à l'Énergie Atomique et aux Énergies Alternatives	CEA	France
4	Centre National de la Recherche Scientifique, Institut National de Physique Nucléaire et de Physique des Particules	CNRS	France
5	Karlsruhe Institute of Technology	KIT	Germany
6	Technical University Darmstadt	TUD	Germany
7	Istituto Nazionale di Fisica Nucleare	INFN	Italy
8	University of Twente	UT	Netherlands
9	ALBA Consorcio para la Construcción, Equipamiento y Explotación del Laboratorio de Luz Síncrotrón (CELLS)	ALBA	Spain
10	Centro de Investigaciones Energéticas, Medioambientales y Tecnológicas	CIEMAT	Spain
11	Science & Technology Facilities Council	STFC	UK
12	The University of Liverpool	UNILIV	UK
13	The Chancellor, Masters and Scholars of the University of Oxford	UOXF	UK
14	Inter-University Research Institute Corporation, High Energy Accelerator Research Organization	KEK	Japan
15	École Polytechnique Fédérale de Lausanne	EPFL	Switzerland
16	Université de Genève	UNIGE	Switzerland