

# Probing Gluon and Sea Quark Polarization with PHENIX

A. Bazilevsky

January 25-31, 2015

Keystone, Colorado



# RHIC Spin

RHIC Spin is a unique program  
PHENIX and STAR are truly complementary

[arXiv: 1501.01220](https://arxiv.org/abs/1501.01220)

The RHIC Spin Program  
Achievements and Future Opportunities

Instead of presenting only PHENIX results I'll  
give you a more complete and coherent picture  
of **Spin results from RHIC**, with focus on  
**longitudinal spin (helicity) measurements**

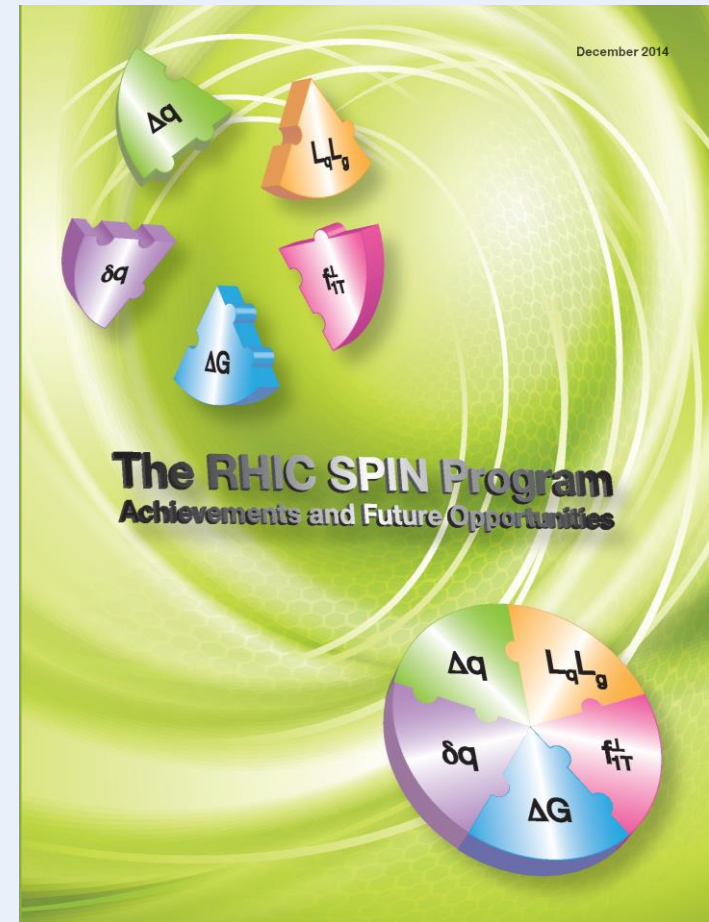

# Nucleon Helicity Structure

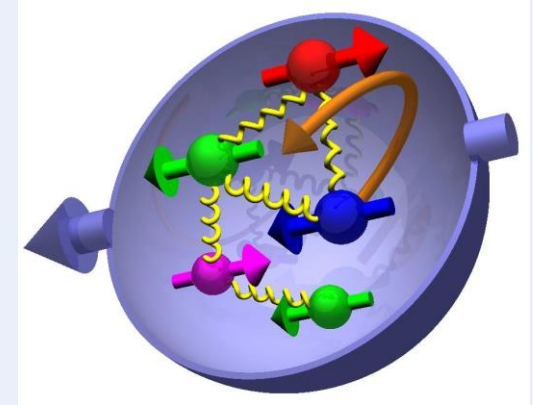
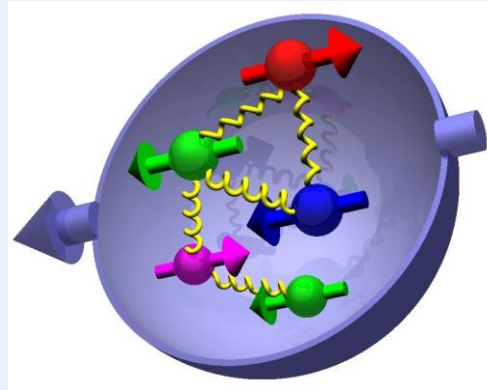
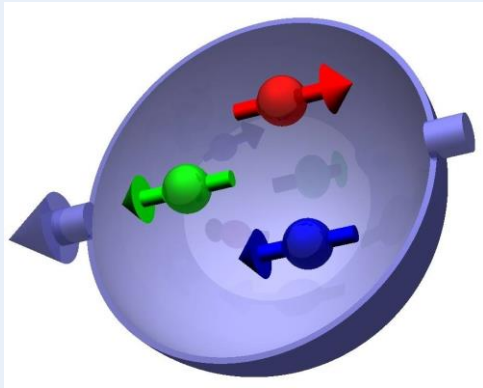

Naïve parton model:

$$\frac{1}{2} = \frac{1}{2}(\Delta u_v + \Delta d_v)$$

⇒ Gluons are polarized ( $\Delta G$ )  
 ⇒ Sea quarks are polarized:

For complete description include parton orbital angular momentum  $L_z$ :

1989 EMC (CERN):  
 $\Delta\Sigma = 0.12 \pm 0.09 \pm 0.14$   
 $\Delta\Sigma = \Delta u + \Delta d + \Delta s + \Delta\bar{u} + \Delta\bar{d} + \Delta\bar{s}$   
 ⇒ Spin Crisis

$$\frac{1}{2} = \frac{1}{2}(\Delta q + \Delta\bar{q}) + \Delta G$$

$$\frac{1}{2} = \frac{1}{2}(\Delta q + \Delta\bar{q}) + \Delta G + L_z$$

Determination of  $\Delta G$  and  $\Delta\bar{q}$  has been the main goal of longitudinal spin program at RHIC

# From DIS to pp:

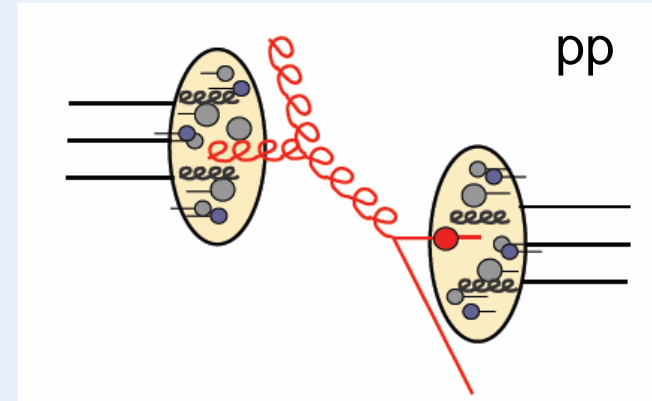
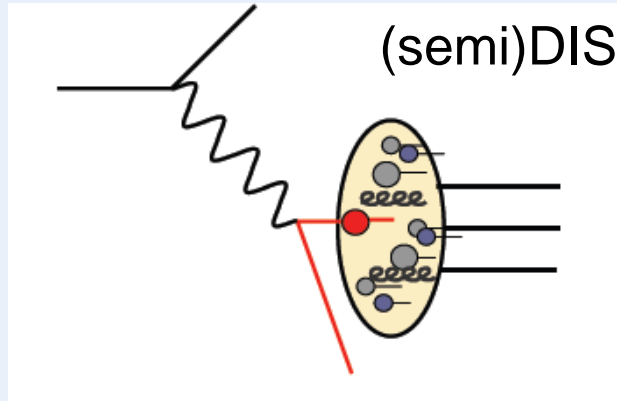

## Probes $\Delta G$ :

$Q^2$  dependence of quark PDFs

Photon-gluon fusion

## (Anti-)quark flavor separation:

Through fragmentation processes

## Probes $\Delta G$ :

Directly from  $gg$  and  $qg$  scattering

## (Anti-)quark flavor separation:

Through  $u\bar{d} \rightarrow W^+$  and  $\bar{u}d \rightarrow W^-$

Complementary approaches

# RHIC as polarized proton collider

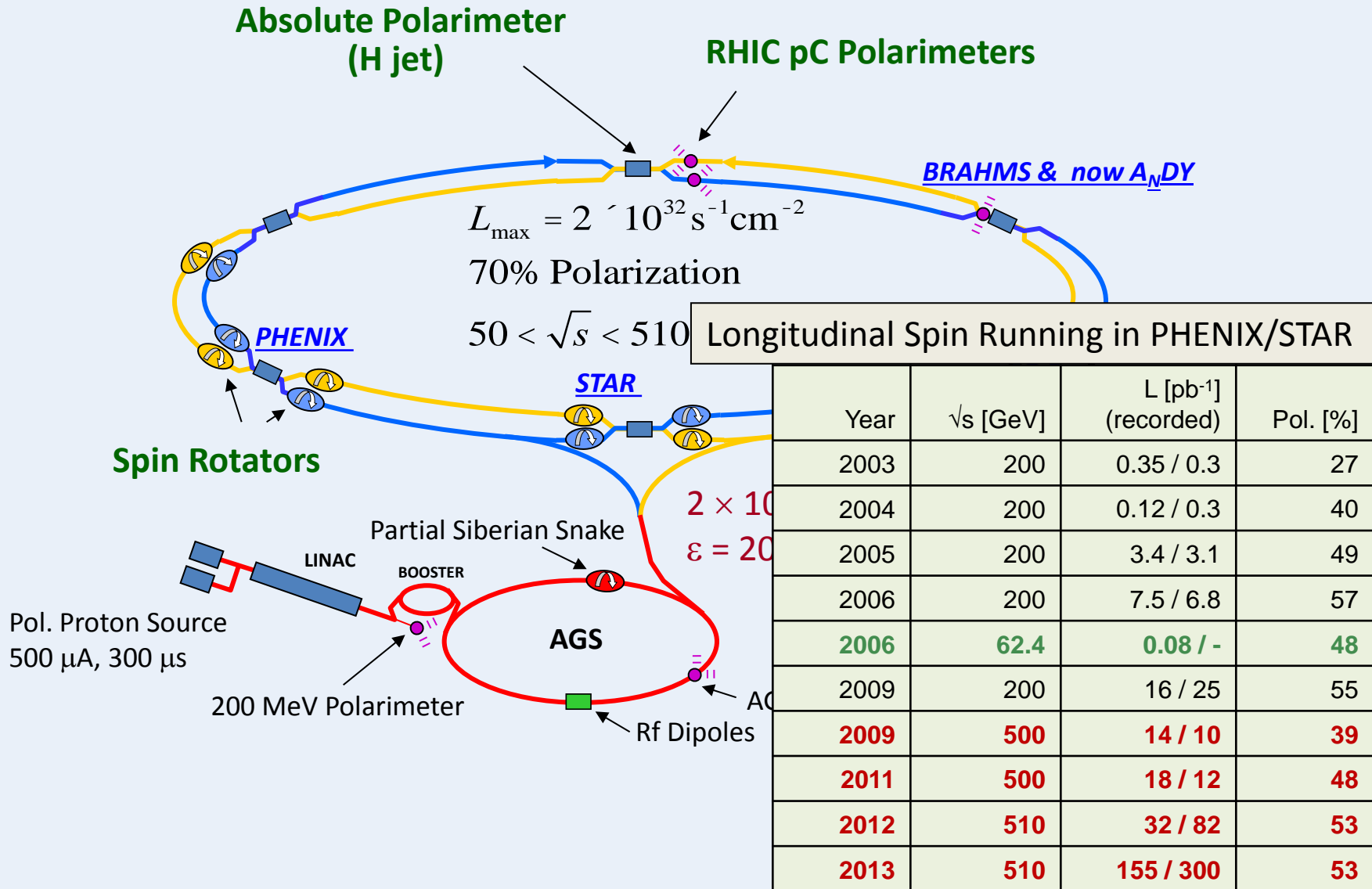

# PHENIX and STAR

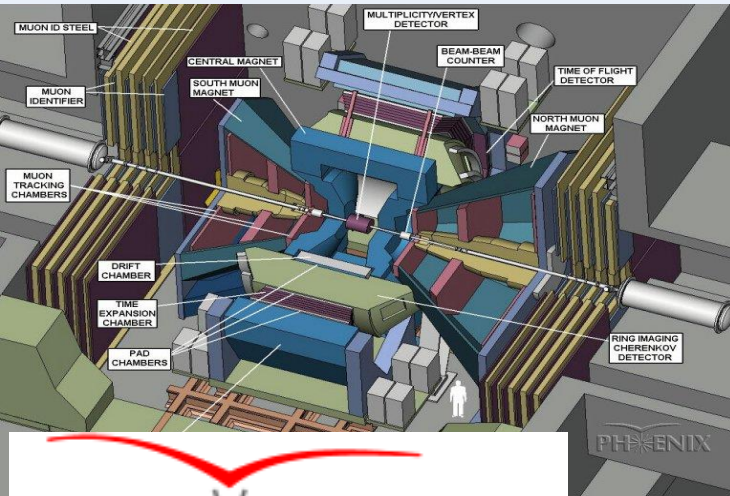

## PHENIX:

High rate capability

High granularity

Good mass resolution and PID

Limited acceptance

Upgraded to forward capabilities, inner tracking

## STAR:

Large acceptance with azimuthal symmetry

Good tracking and PID

Central and forward calorimetry

Upgrades to higher rate capabilities,

Inner tracking

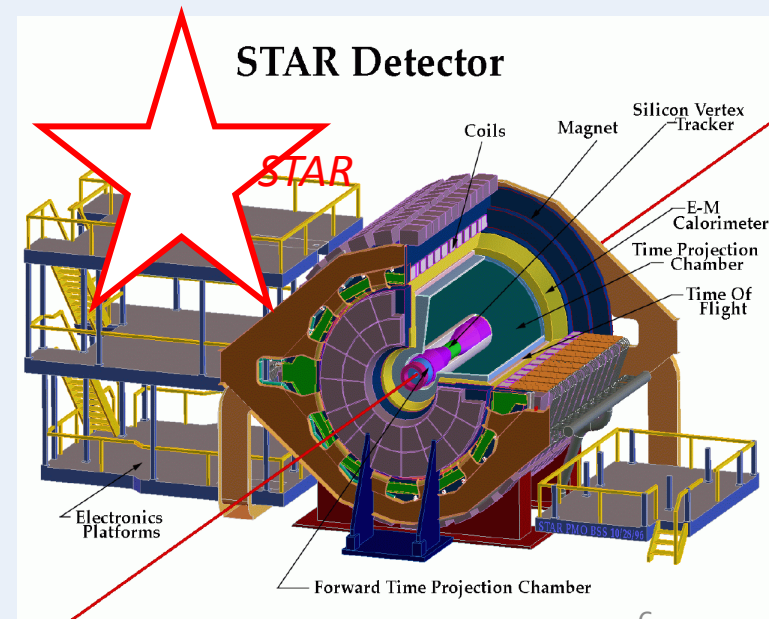

# Probing $\Delta G$ in pol. pp collisions

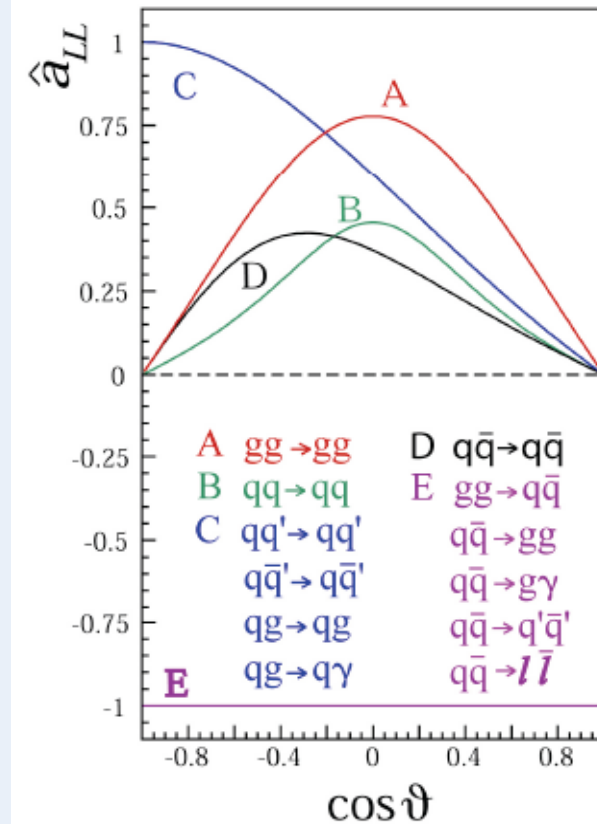
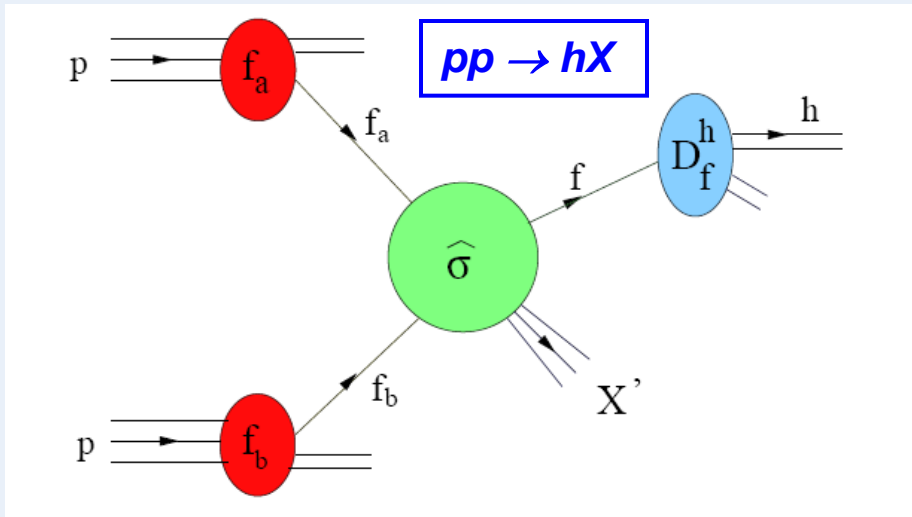

$$A_{LL} = \frac{d\sigma^{++} - d\sigma^{+-}}{d\sigma^{++} + d\sigma^{+-}} = \frac{\sum_{a,b} \Delta f_a \otimes \Delta f_b \otimes d\hat{\sigma}^{f_a f_b \rightarrow fX} \cdot \hat{a}_{LL}^{f_a f_b \rightarrow fX} \otimes D_f^h}{\sum_{a,b} f_a \otimes f_b \otimes d\hat{\sigma}^{f_a f_b \rightarrow fX} \otimes D_f^h}$$

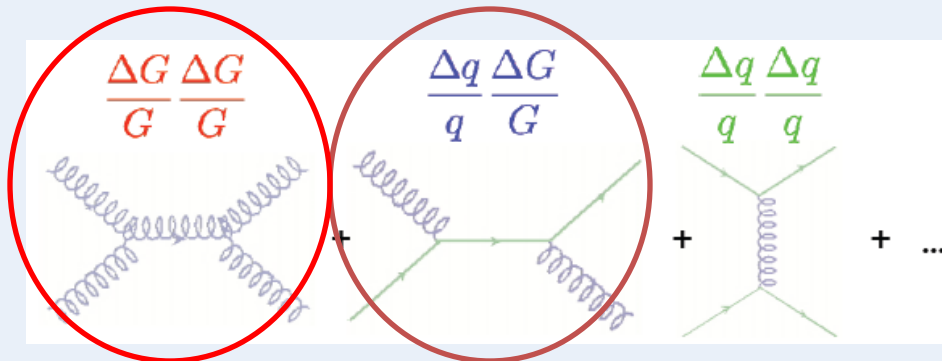

Double longitudinal spin asymmetry  $A_{LL}$  is sensitive to  $\Delta G$

# $\Delta G$ : $\pi^0$ and jet $A_{LL}$

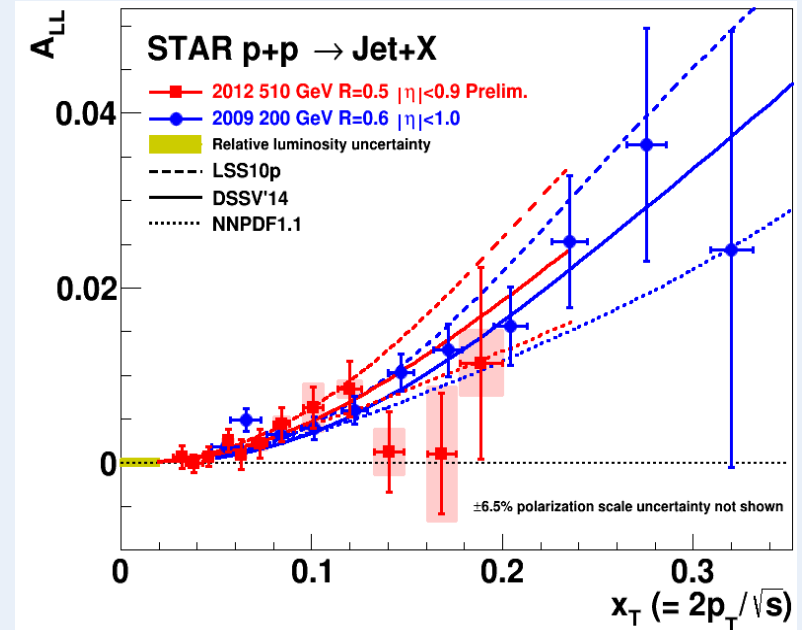
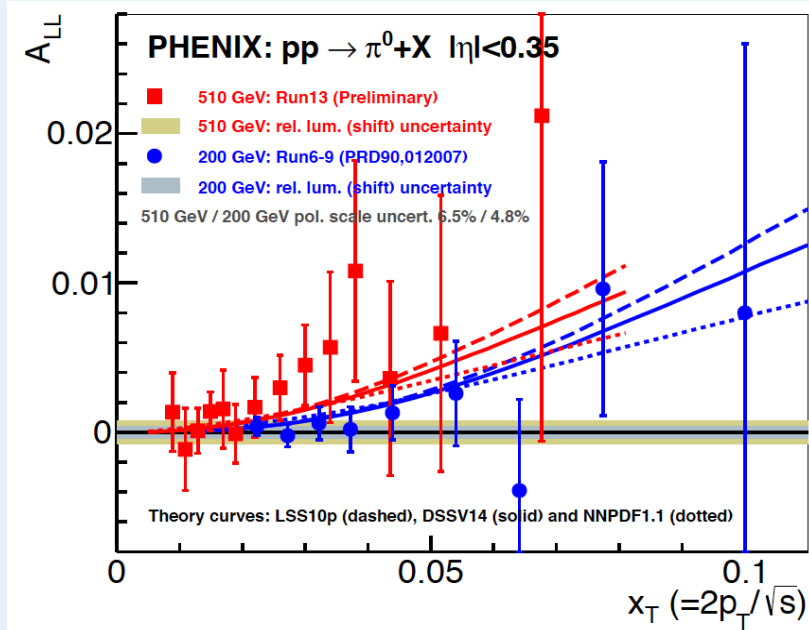

First observation of non-zero  $A_{LL}$  associated with non-zero  $\Delta G$  !

# $\Delta G$ : DIS+pp global QCD fit

DSSV:

D. de Florian  
R. Sassot  
M. Stratmann  
W. Vogelsang

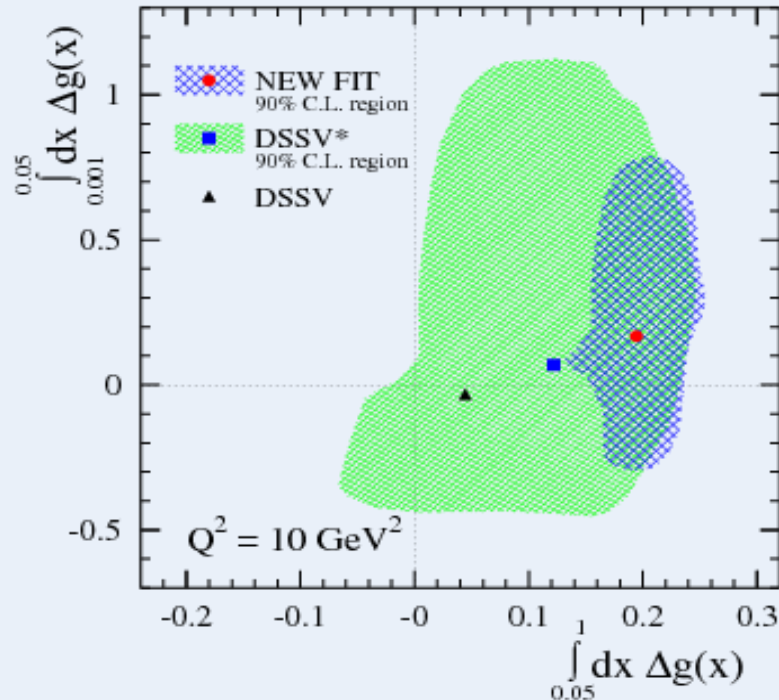

DSSV: Phys Rev Lett, 101, 072001 (2008)

Data from up to 2006

New DSSV: Phys Rev Lett, 113, 012001 (2014)

Data from up to 2009

$$\int_{0.05}^1 dx Dg(x) = 0.2^{+0.06}_{-0.07}$$

Significant non-zero  $\Delta g(x)$  in the kin. region probed by RHIC

Similar result from another global fit NNPDF

Still huge uncertainty in unmeasured region ( $x < 0.05$ )

=> Measurements at higher  $\sqrt{s}$  and forward rapidity

# $\Delta G$ : Near Term Projections

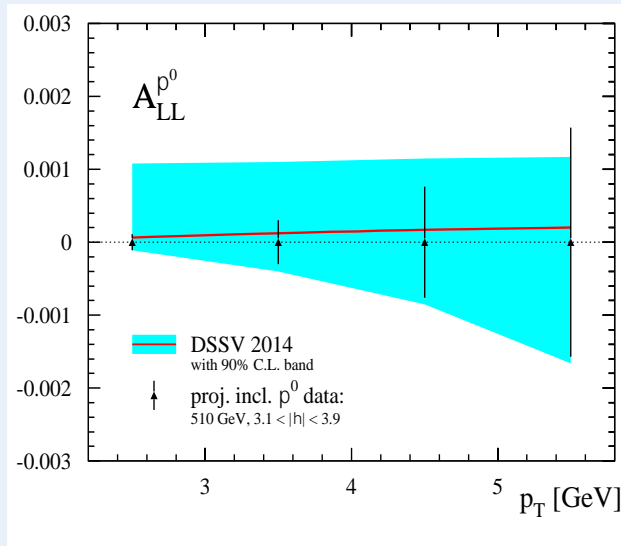

$\pi^0$  in forward region at  $\sqrt{s}=510$  GeV (PHENIX):  
Based on collected 2013 data  
Probes lower  $x$  down to  $\sim 10^{-3}$

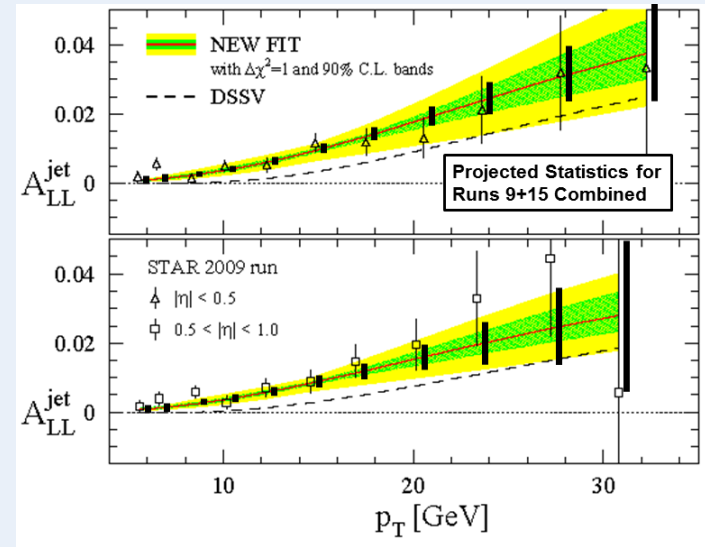

Inc. Jet at  $\sqrt{s}=200$  GeV (STAR):  
Based on 2009/15 data  
Considerably improve exp. precisions

# $\Delta G$ : Near Term Projections

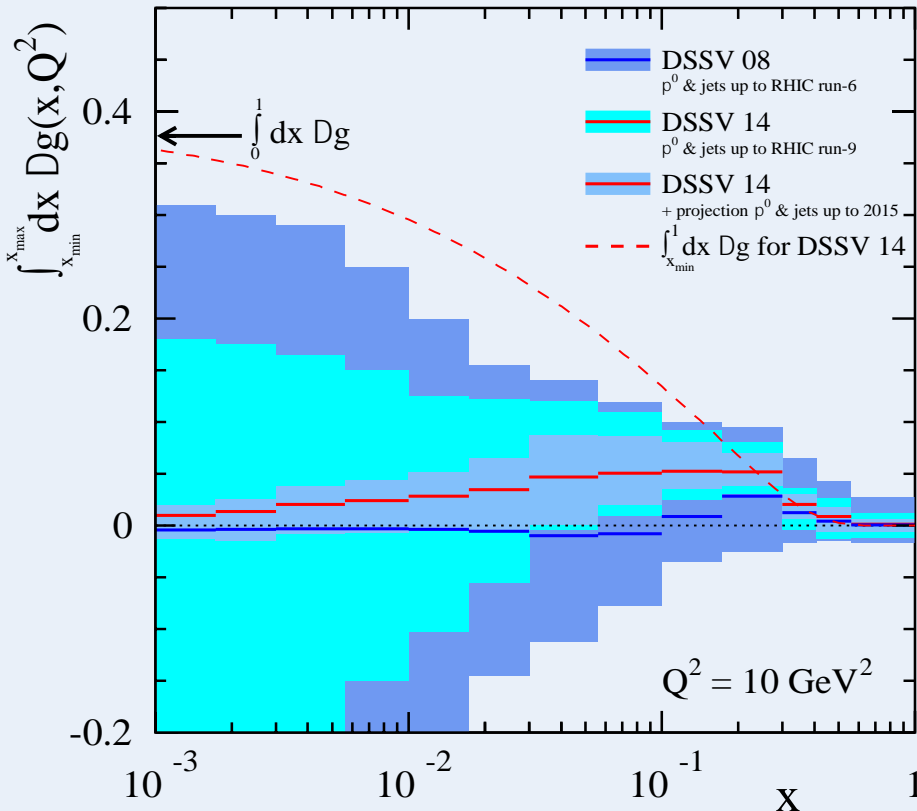

$\Delta G$  fit in each  $x$  bin

Innermost band: after inclusion of projected data up to 2015

$x > 0.01$  mainly from central rap. data  
 $x < 0.01$  mainly from forward rap. data

Significant improvement expected soon, particularly at  $x < 0.03$

Other channels are also being measured

$\gamma$ ,  $\eta$ ,  $\pi^\pm$ ,  $h^\pm$ , heavy flavor through  $e$  and  $\mu$   
 jet-jet,  $h$ - $h$ ,  $\gamma$ -jet,  $\gamma$ - $h$

Will serve for syst. effects study in  $\Delta g(x)$  fit

# (Anti)quark flavor separation

DSSV: PRL 101, 072001 (2008)

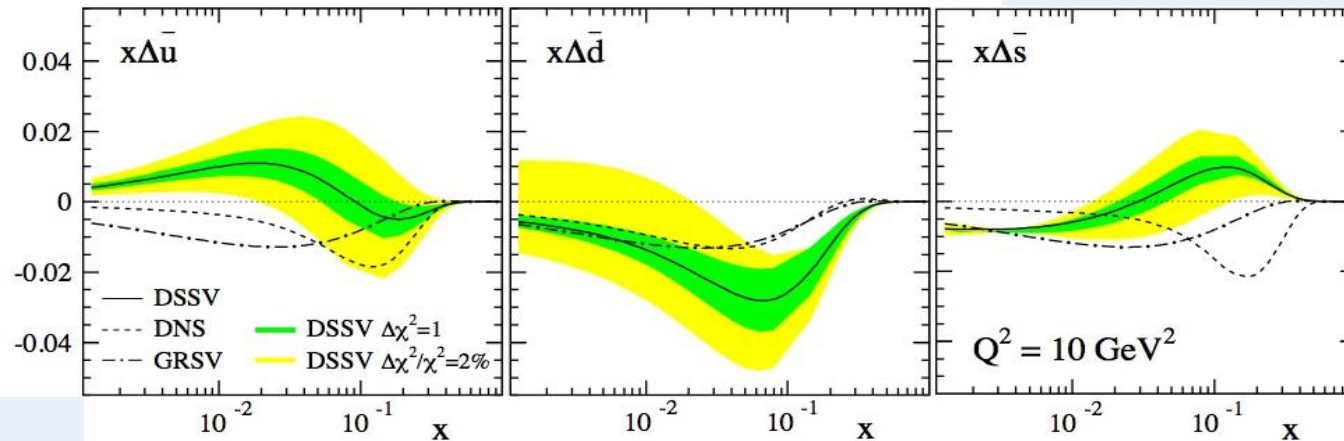

Mainly from **SIDIS**:

Fragmentation functions to tag (anti)quark flavor

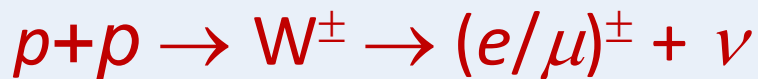

➤ Parity violating W production:

Fixes quark helicity and flavor:

$$d_L \bar{u}_R \rightarrow W^- \quad u_L \bar{d}_R \rightarrow W^+$$

➤ No fragmentation involved

➤ High  $Q^2$  (set by W mass)

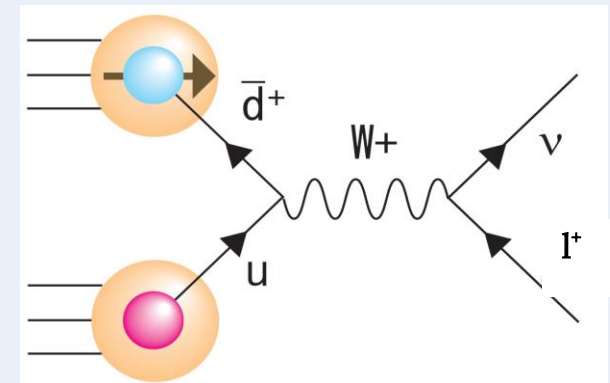

$$A_L^{W^+} = \frac{-D u(x_1) \bar{d}(x_2) + D \bar{d}(x_1) u(x_2)}{u(x_1) \bar{d}(x_2) + \bar{d}(x_1) u(x_2)}$$

# W: $A_L$ vs $\eta$

$$A_L^{W^+} = \frac{-Du(x_1)\bar{d}(x_2) + D\bar{d}(x_1)u(x_2)}{u(x_1)\bar{d}(x_2) + \bar{d}(x_1)u(x_2)}$$

$$A_L^{W^-} = \frac{-Dd(x_1)\bar{u}(x_2) + D\bar{u}(x_1)d(x_2)}{d(x_1)\bar{u}(x_2) + \bar{u}(x_1)d(x_2)}$$

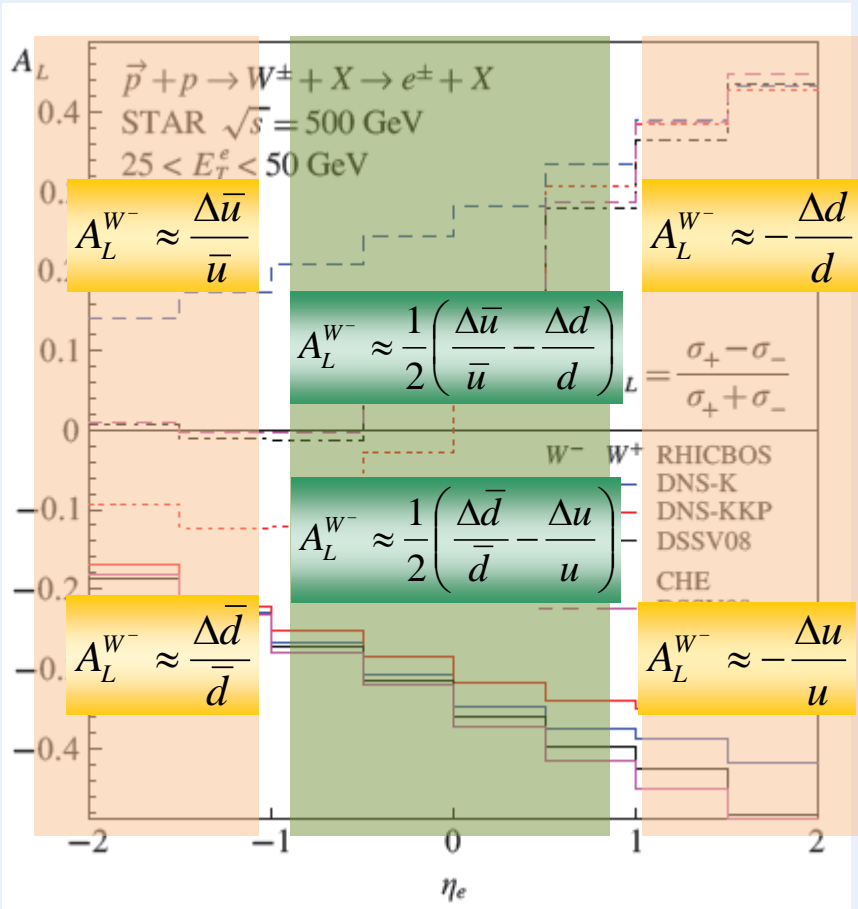

## STAR

Central (barrel) region ( $W \rightarrow e^\pm$ ,  $|\eta| < 1$ )

Data from 2009: **PRL106, 062002 (2011)**

Data from 2011/12: **PRL113, 072301 (2014)**

Forward (endcup) region ( $W \rightarrow e^\pm$ ,  $1 < |\eta| < 2$ ):

Forward tracker upgrade, first data from 2013

## PHENIX

Central Arms ( $W \rightarrow e^\pm$ ,  $|\eta| < 0.35$ )

2009 data: **PRL106, 062001 (2011)**

2011-13 data: **"Preliminary"**

Forward Arms ( $W \rightarrow \mu^\pm$ ,  $1.2 < |\eta| < 2.4$ ):

2011-13 data: **"Preliminary"**

Crucial to measure in wide rapidity range

# Central region: $W^{\pm} \rightarrow e^{\pm}$

- Triggered by energy in EMCal
- Momentum from energy in EMCal
- Charge from tracking in B field

PHENIX:  $|\eta| < 0.35$

STAR:  $|\eta| < 0.5$

STAR:  $0.5 < |\eta| < 1.1$

$W^- \rightarrow e^-$

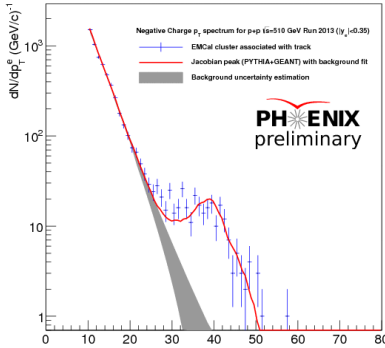

$W^+ \rightarrow e^+$

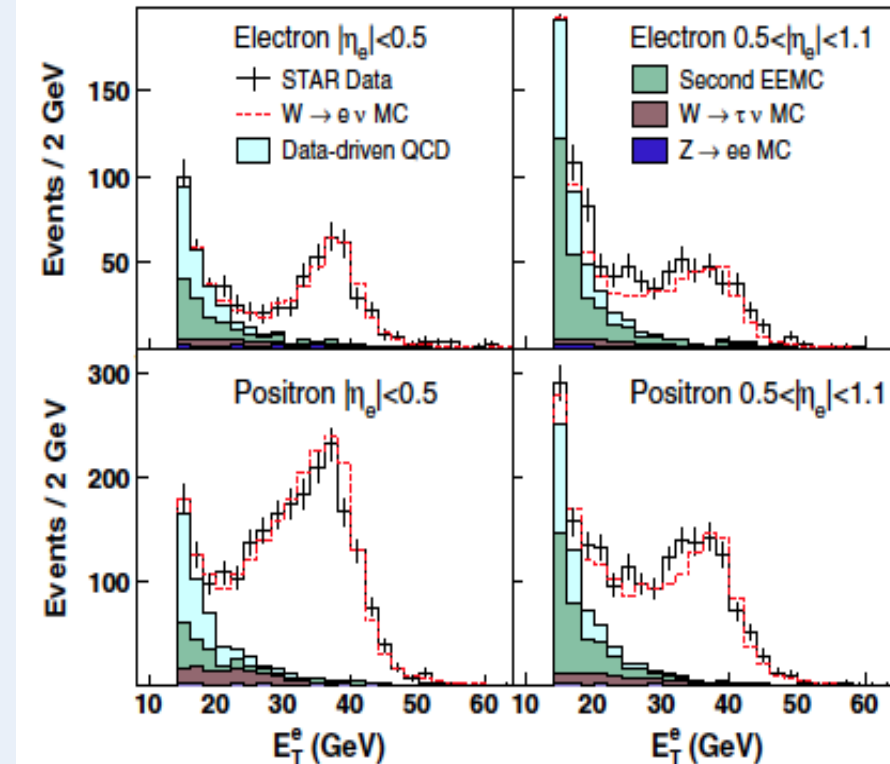
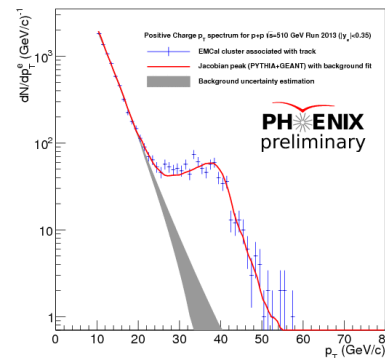

# Cross section

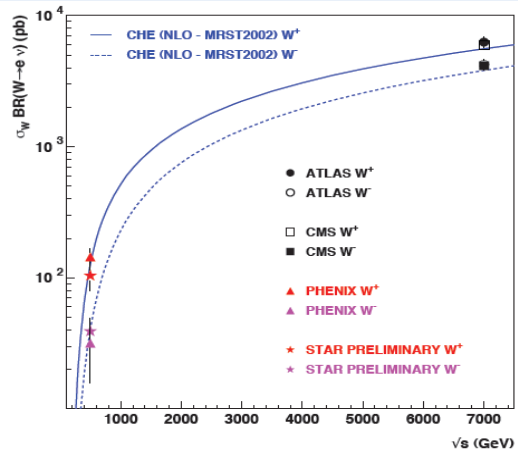

# Central region: $W^\pm \rightarrow e^\pm$

PHENIX: 2011-13

STAR: 2011/12

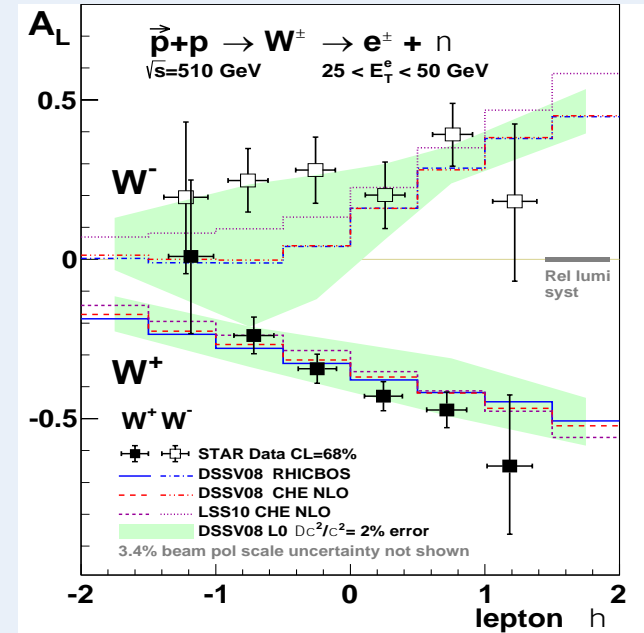
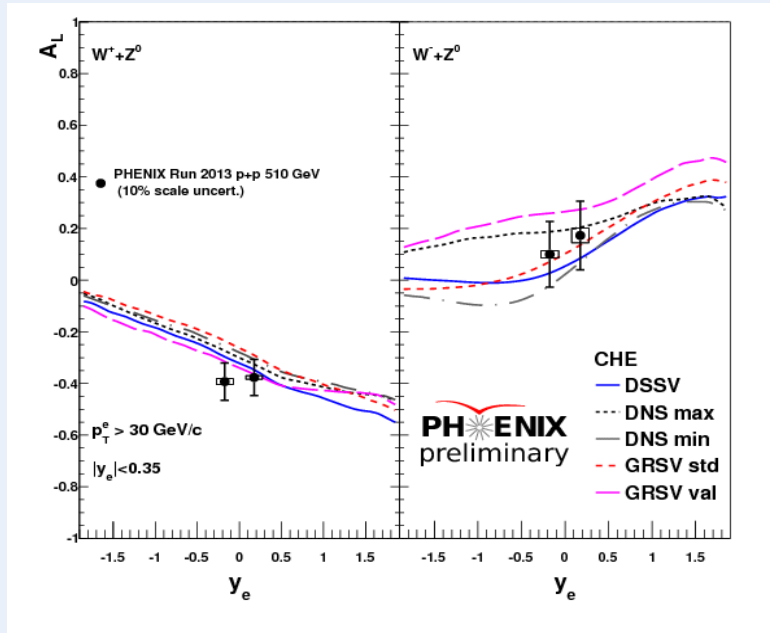

$\Delta u$ -bar tends to be more positive  
 Symmetry breaking in polarized quarks?

# W: Central vs Forward region

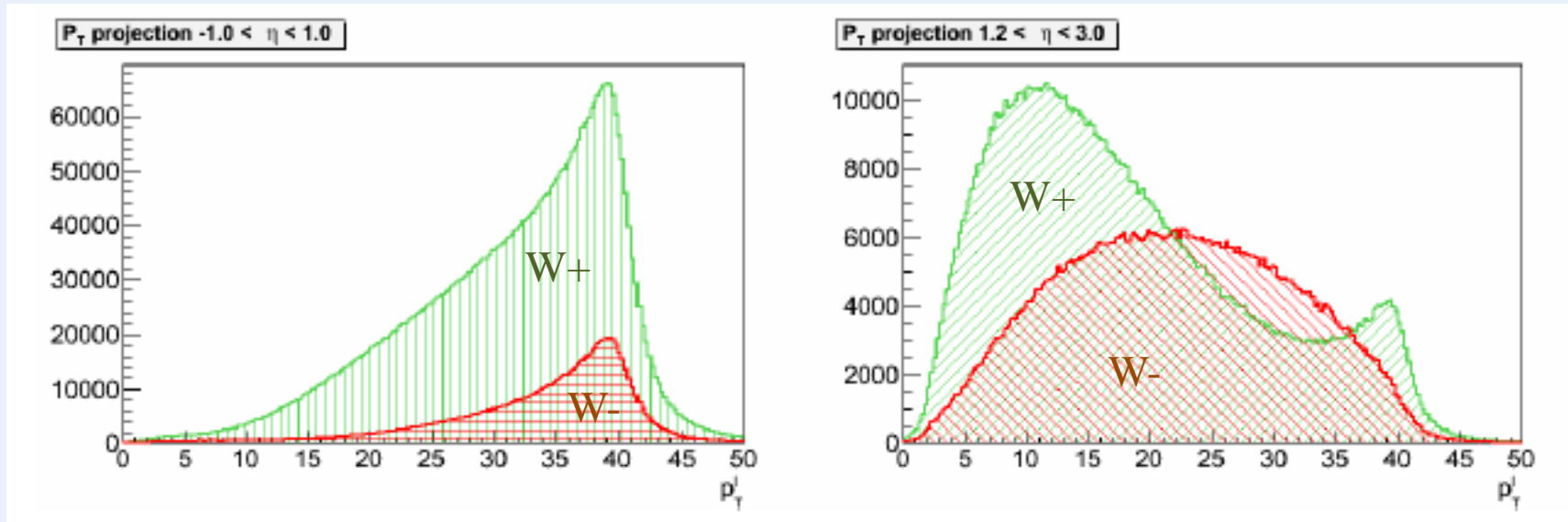

Clear Jacobian peak  
at central rapidities

Suppressed/No Jacobian peak  
at forward rapidities

# Forward region: $W^\pm \rightarrow \mu^\pm$

## PHENIX

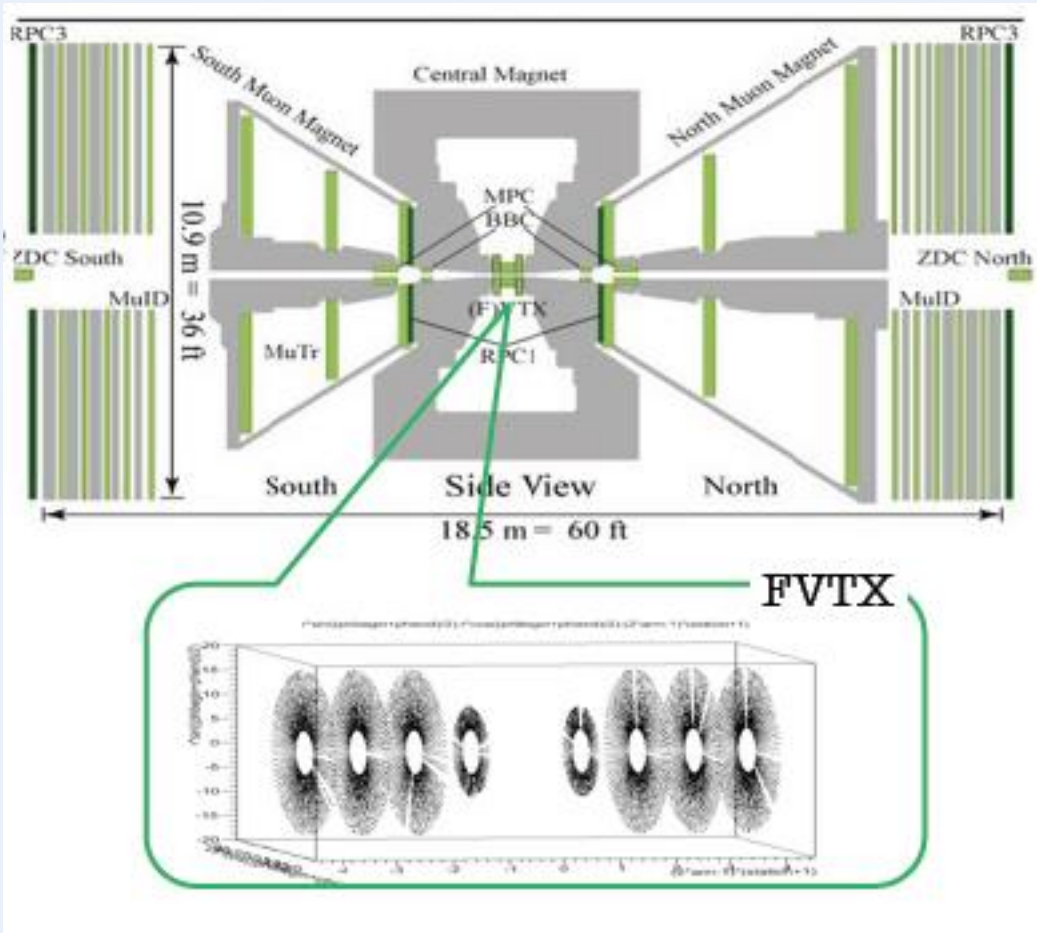

**Muon Arms:  $1.2 < |\eta| < 2.4$   $\Delta\phi = 2\pi$**

**Muon Tracker (MuTr)**

Tracking, Momentum

**Muon Identifier (MuID)**

$\mu/h$  separation

**Resistive Plate Chamber (RPC)**

Timing, background rejection

**Forward Vertex Detector (FVTX)**

More precise tracking, background rejection

**Dedicated Trigger**

Based on MuTr and RPC

To tag high  $p_T$  muons

# Forward region: $W^\pm \rightarrow \mu^\pm$

## PHENIX

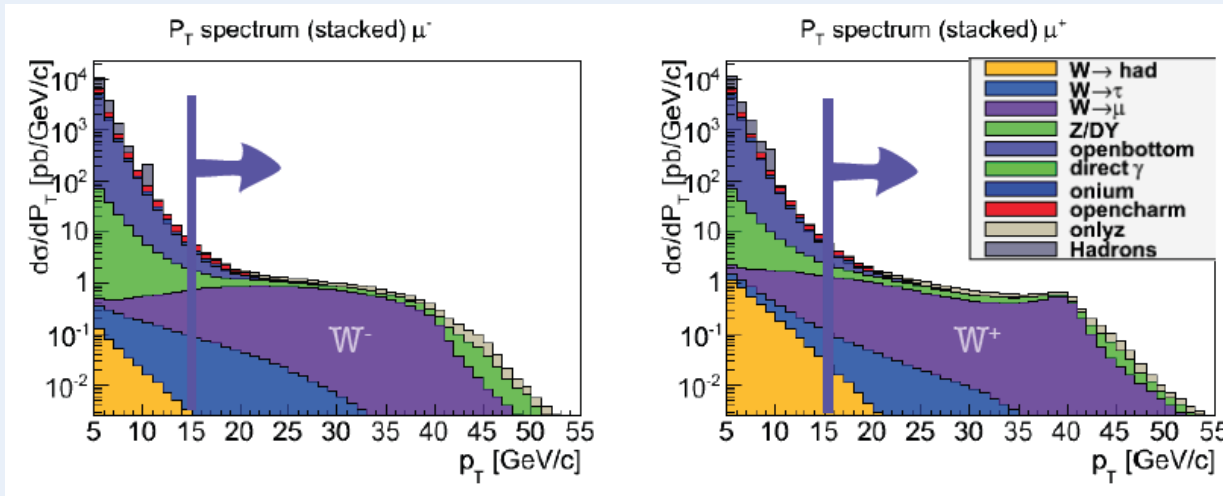

Muon background:

- Heavy flavor
- Quarkonia
- Decay muons
- Z/DY
- Etc.

Not significant at  $>15$  GeV/c

If include hadrons  
(misidentified as  $\mu$ ),  $h \rightarrow \mu$  (fake  
high  $p_T$ ) and  $p_T$  smearing

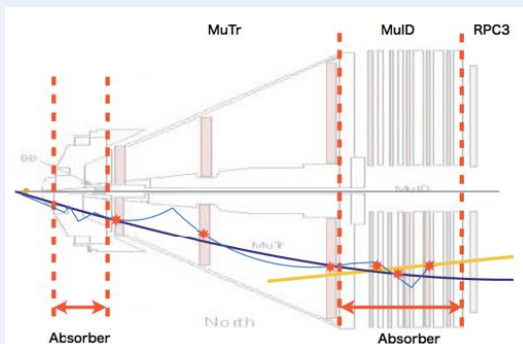

**Total background, accounting for all sources and smearing:**

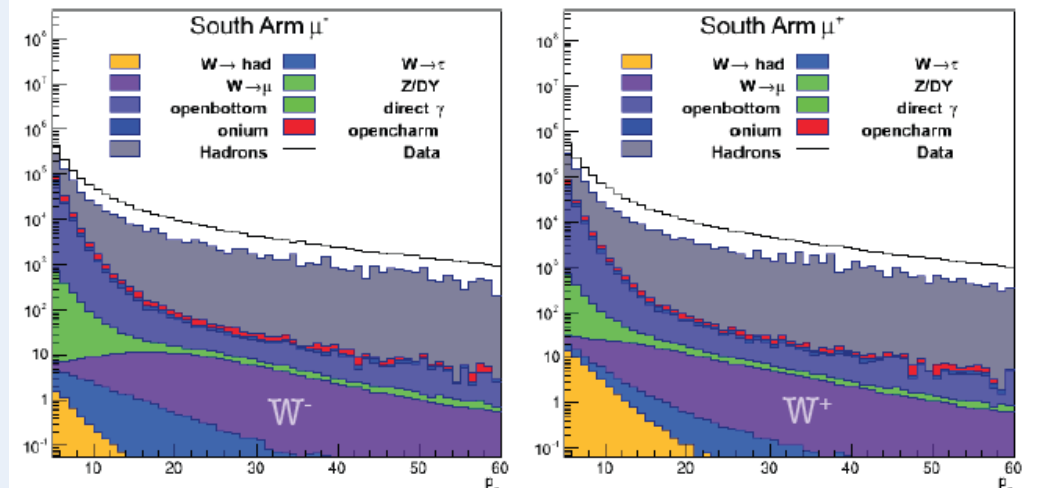

# Forward region: $W^\pm \rightarrow \mu^\pm$

## PHENIX

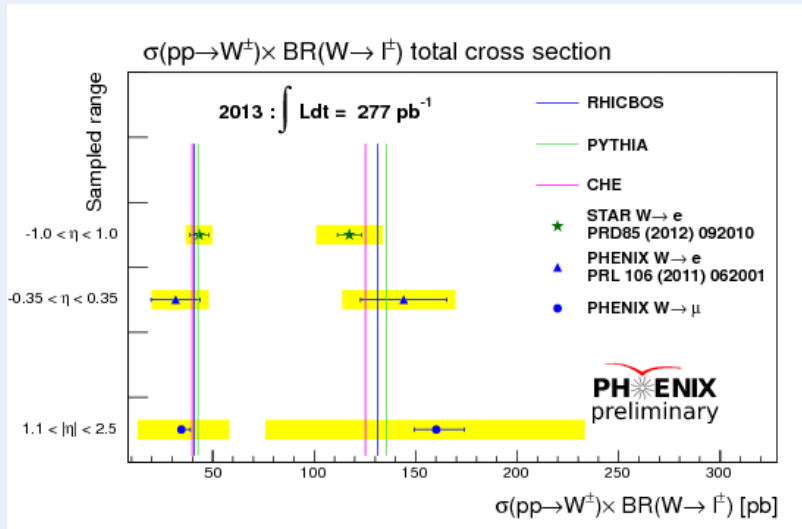

$S/B = 0.2-1$  depending on  $\eta$

Measured cross section agrees with calculations within large uncertainties

$A_L$  uncertainties are still large

Improve  $S/B$

Tracking alignment  $\rightarrow$  reduce momentum smearing and improve charge reco

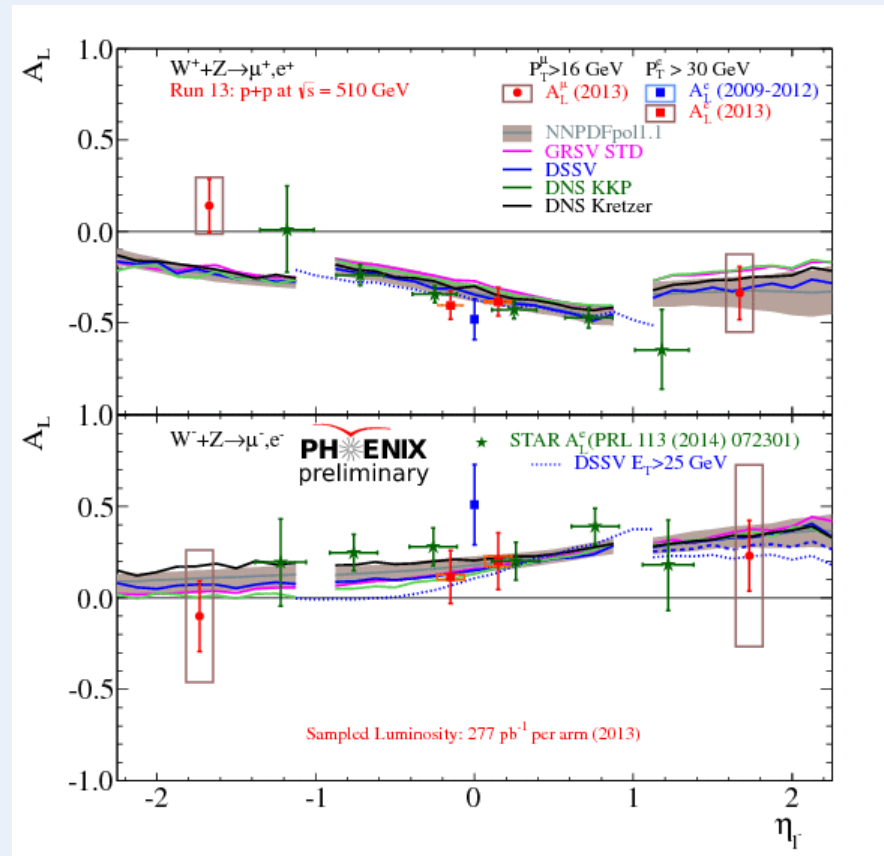

# W: projection

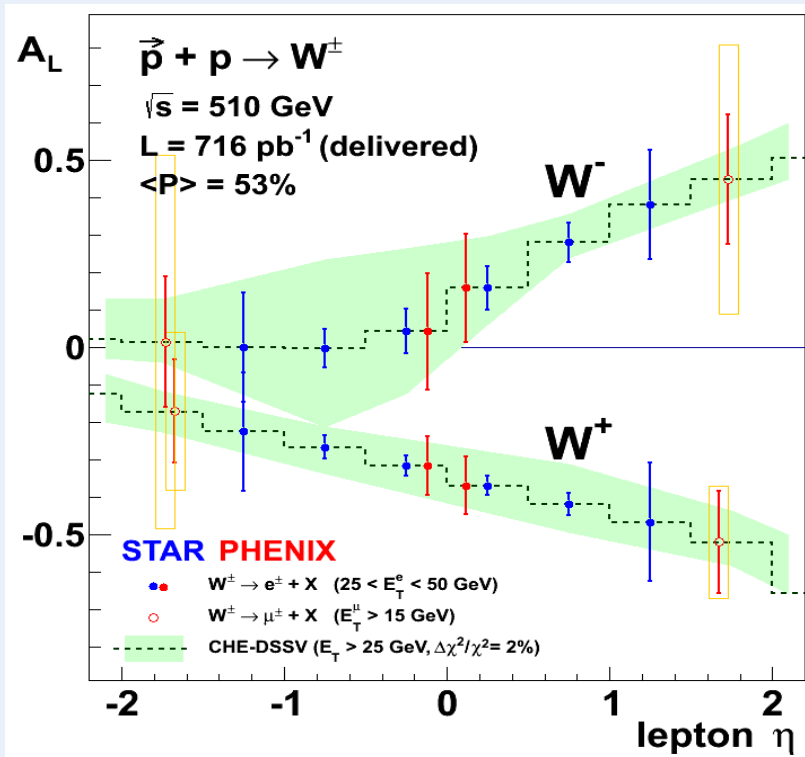

$\Delta\bar{u}$

$\Delta\bar{d}$

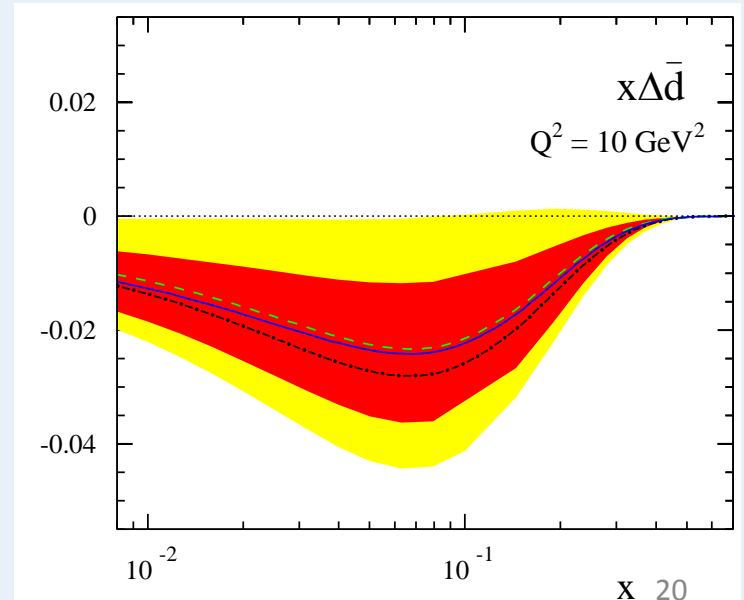
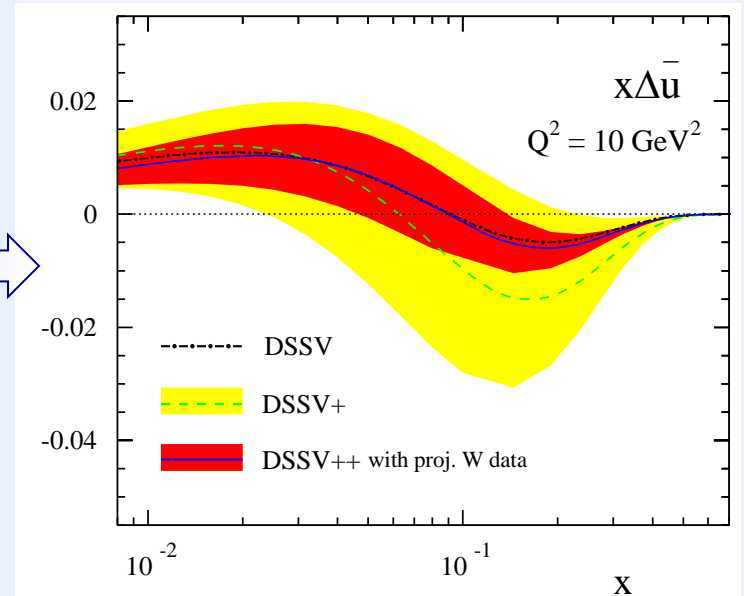

RHIC W-data will give a significant constraint on anti-quark polarization in the proton

# RHIC -> eRHIC

## Electron – Ion Collider

Add electron ring to existing RHIC proton/heavy\_ion ring or  
Add proton/heavy\_ion ring to existing electron ring

Back to DIS but at much higher luminosity (x100-1000 as HERA)

And much higher  $\sqrt{s}$  (with both beams polarized)

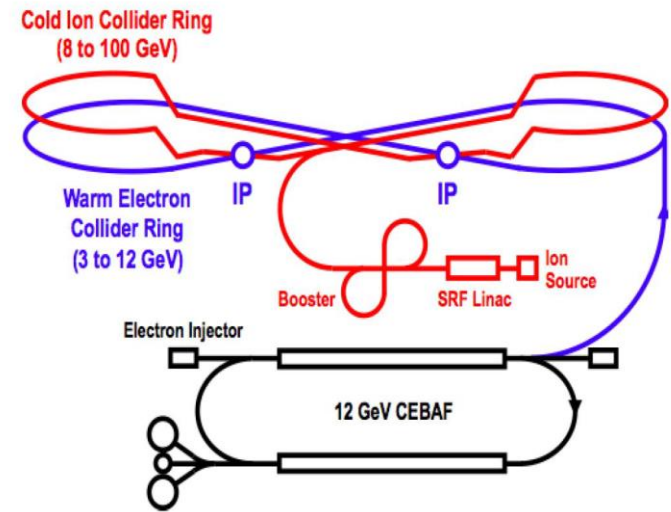
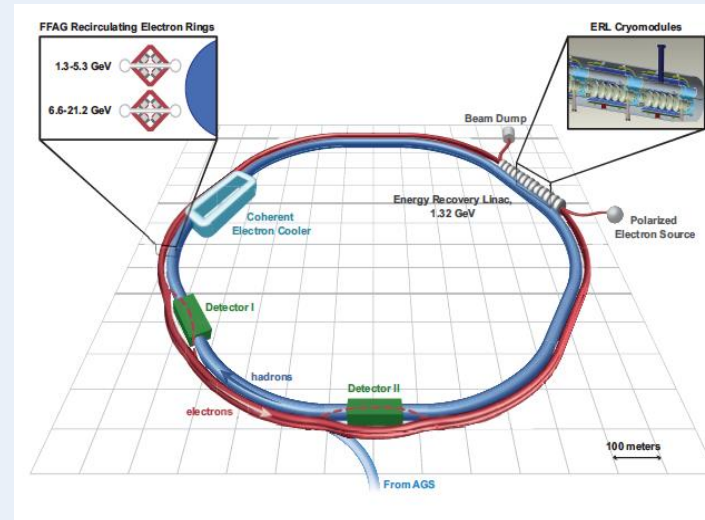
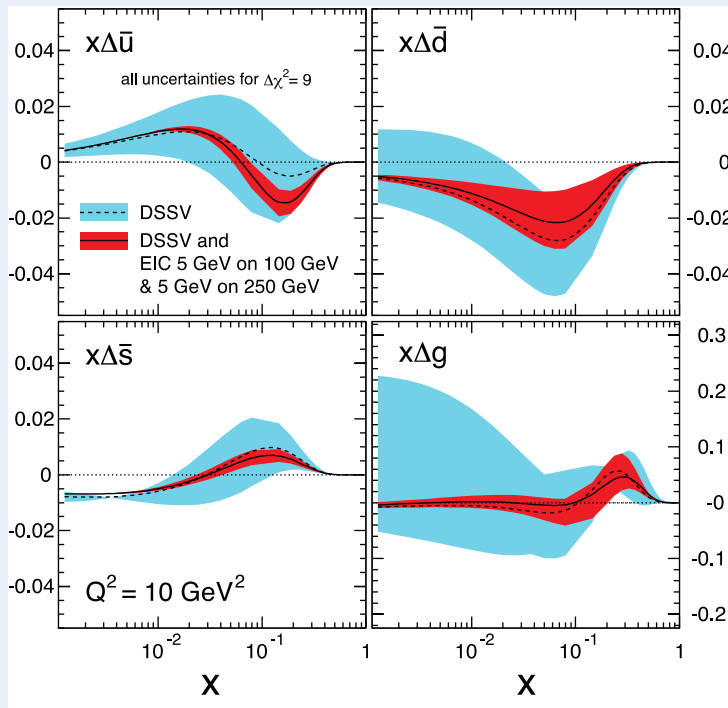

# Summary

## RHIC Longitudinal Spin program:

### How do gluon contribute to the proton Spin

Non-zero (in the limited x-range) and comparable to quark contribution

Plan to study lower x (data already collected!)

### What is the flavor structure of polarized sea in the proton

$\Delta u$ -bar tends to be positive,  $\Delta d$ -bar tends to be negative

Will see the more precise conclusion very soon

# Backup

# Outlook

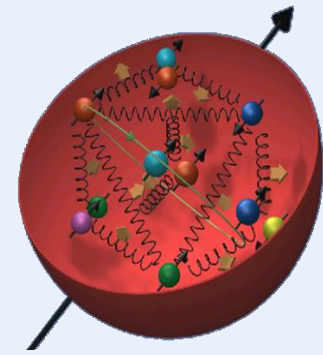

Proton Spin

$$\frac{1}{2} = \frac{1}{2} \Delta\Sigma + \Delta G + L_z$$

(Anti)quark  
Contribution:  
0.15-0.20

Gluon  
Contribution:  
0.1 in  $0.05 < x < 0.2$

Parton Orbital  
Momentum:  
???

Lattice QCD:

quark contributions to the proton spin

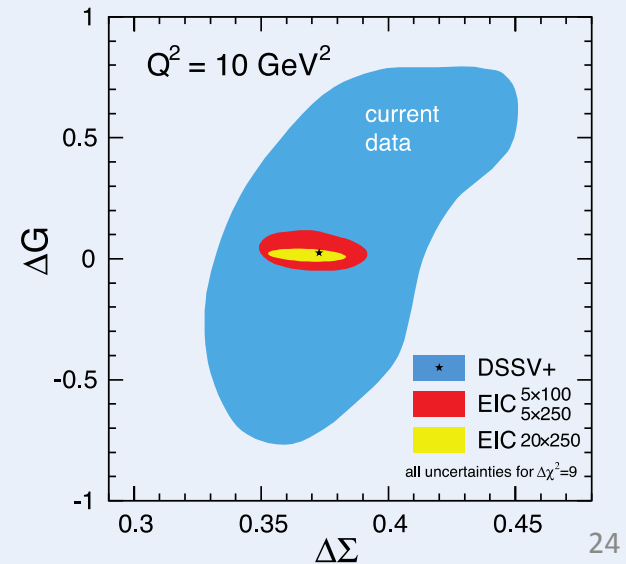
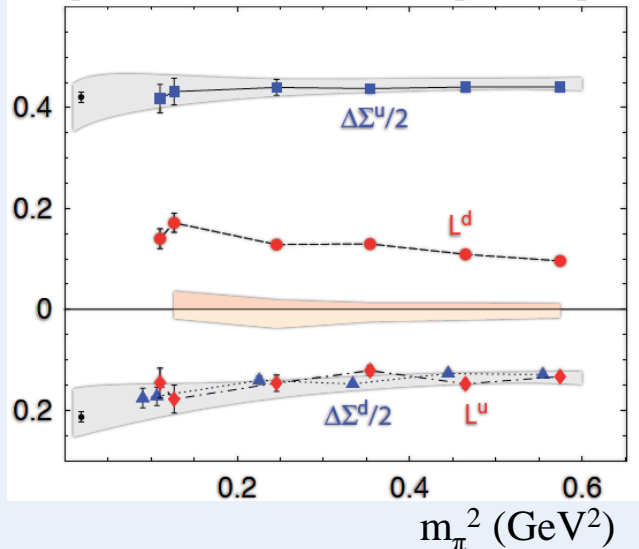

# $\Delta G$ : Near Term Projections

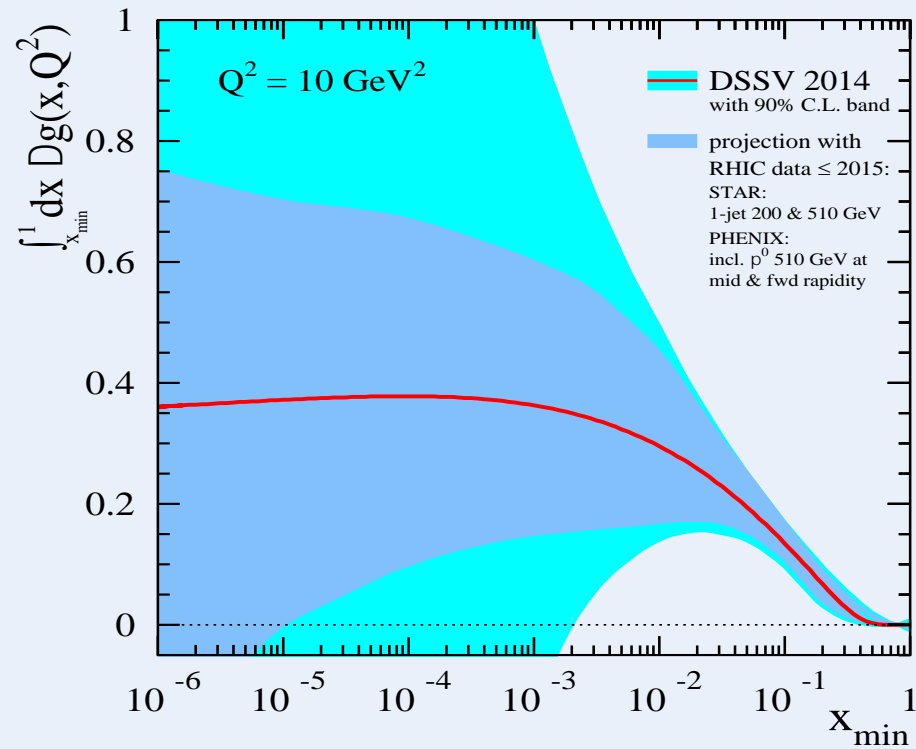

# $\Delta G$ : Near Term Projections

## Di-Jet projections in STAR

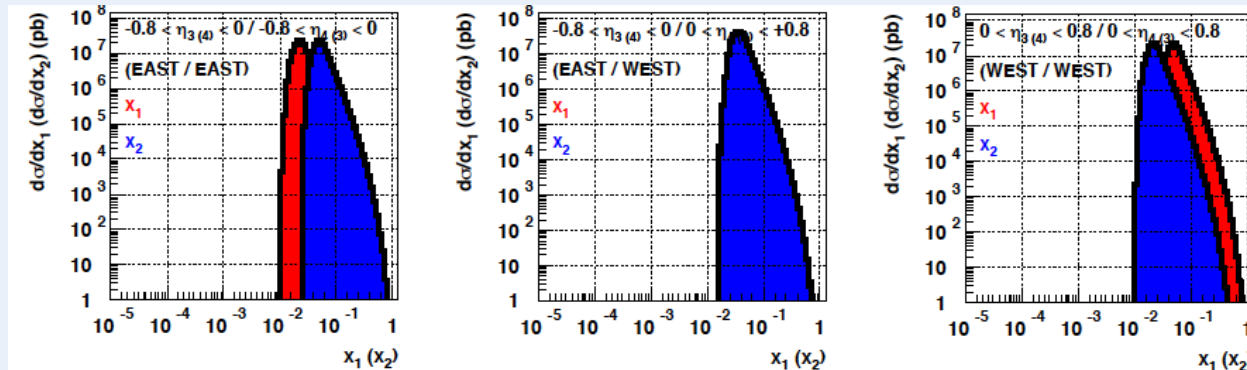
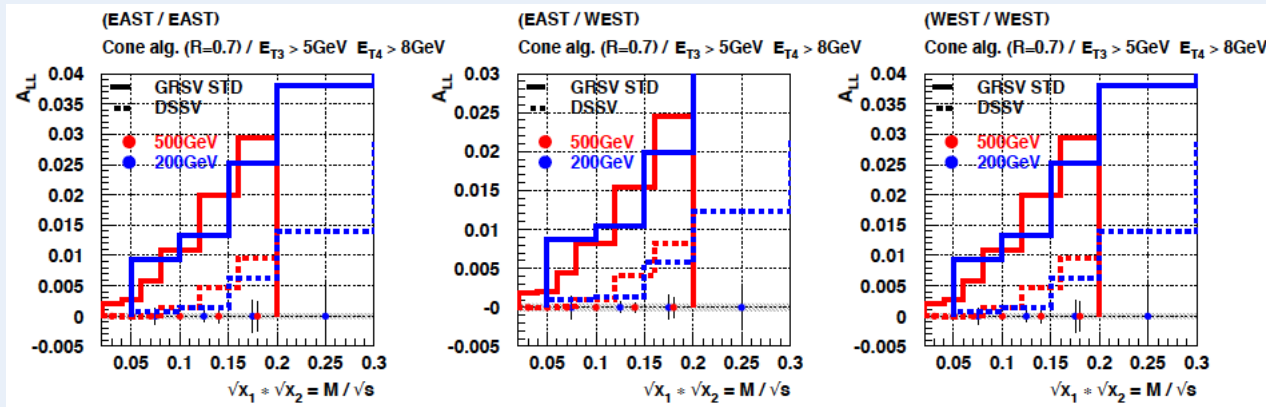

# W: Decay lepton kinematics

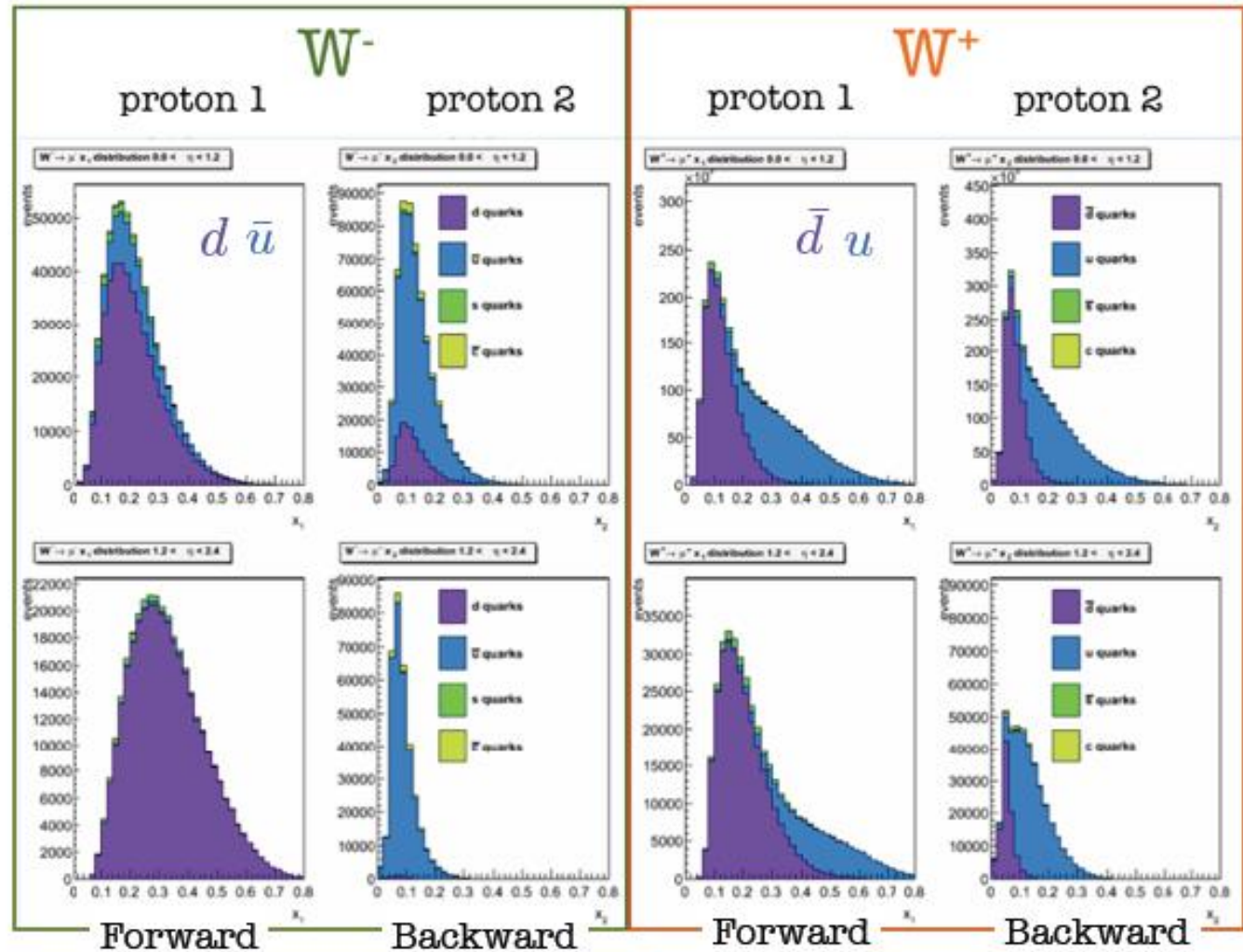
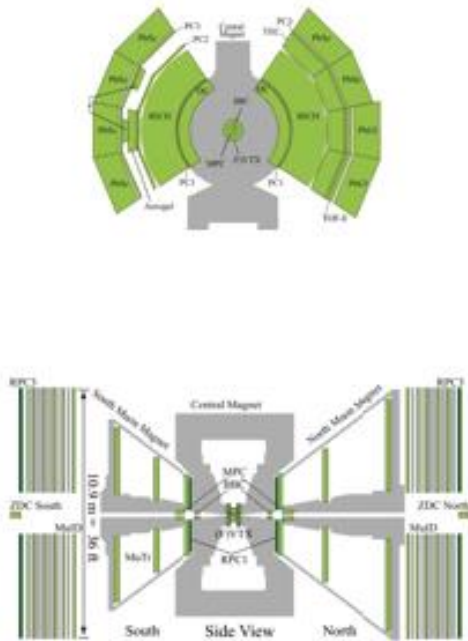

# W: STAR Projection

STAR Run 2013 Projection

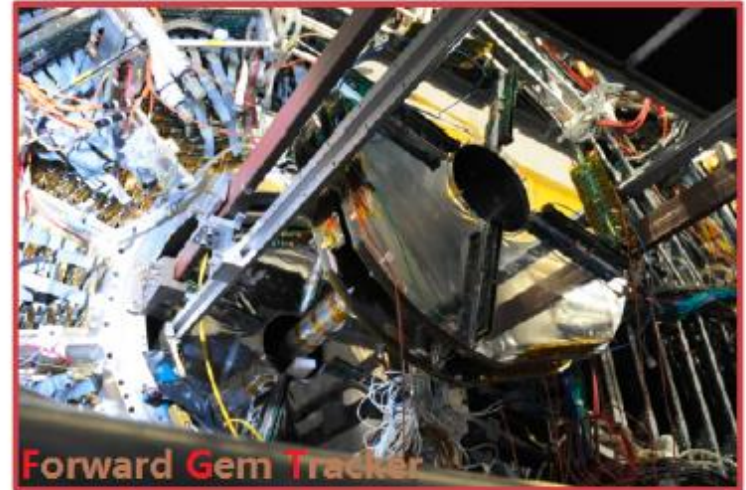
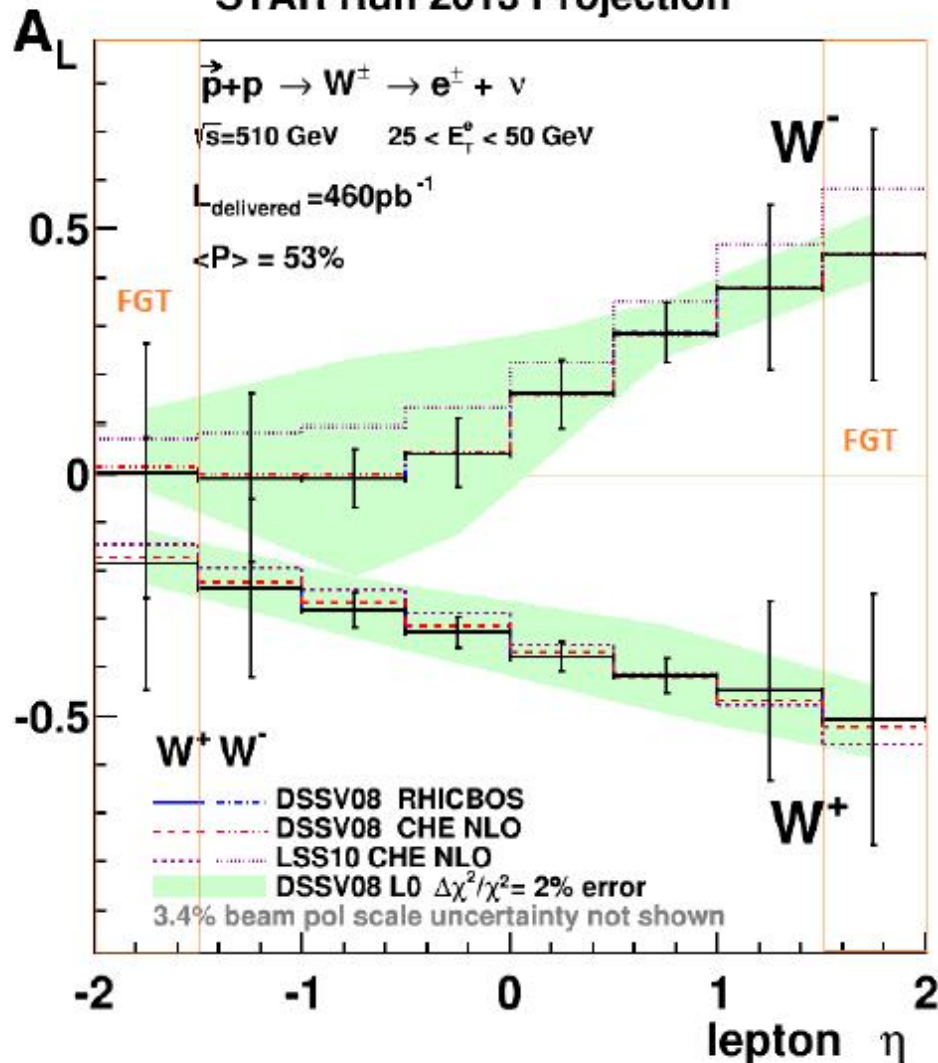

FGT was fully installed for Run13

- Extension of backward and forward acceptance enhances sensitivity to  $\bar{u}$  and  $\bar{d}$  quark polarization
- Higher precision result is expected from much larger statistics of run13 database (being analyzed).

# Central region: $W^\pm \rightarrow e^\pm$

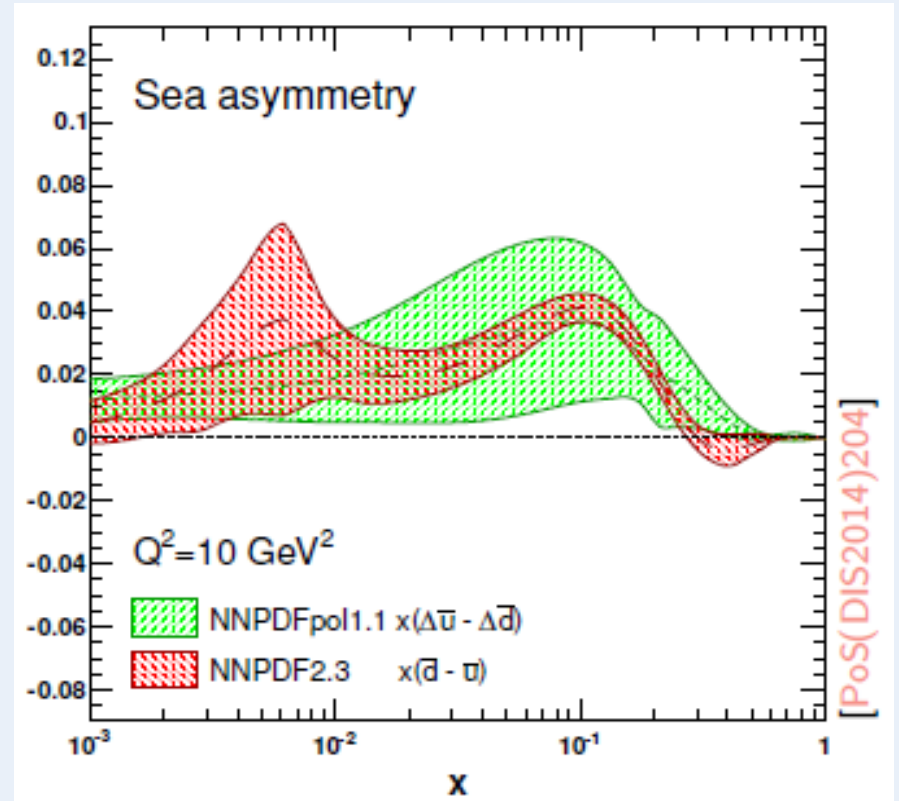
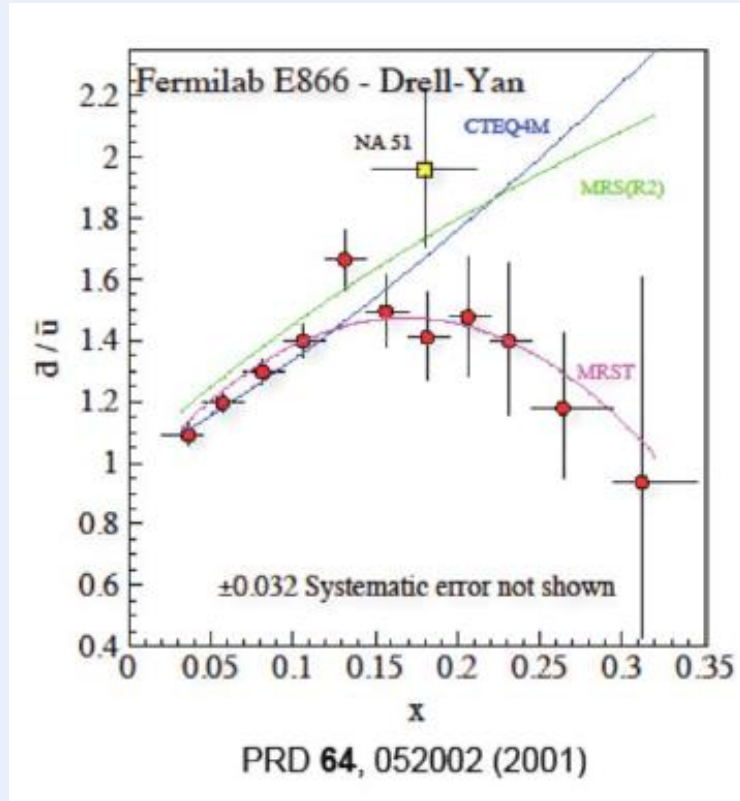

Unpolarized sea is not symmetric

Symmetry breaking in polarized sea?

# From Inclusive Pol. DIS

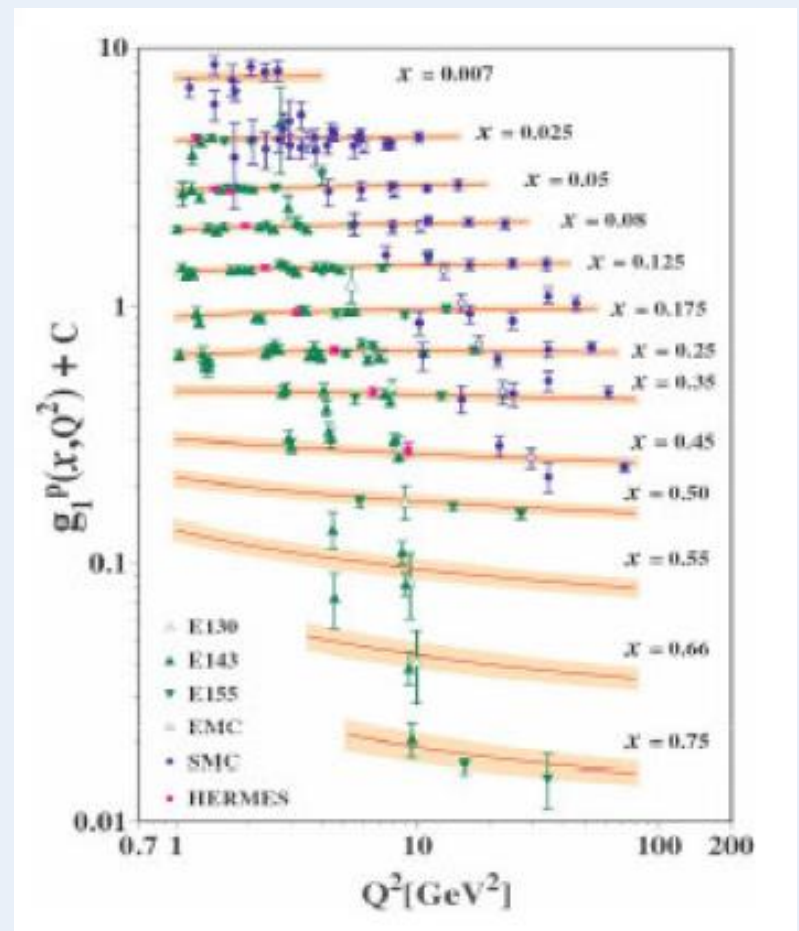
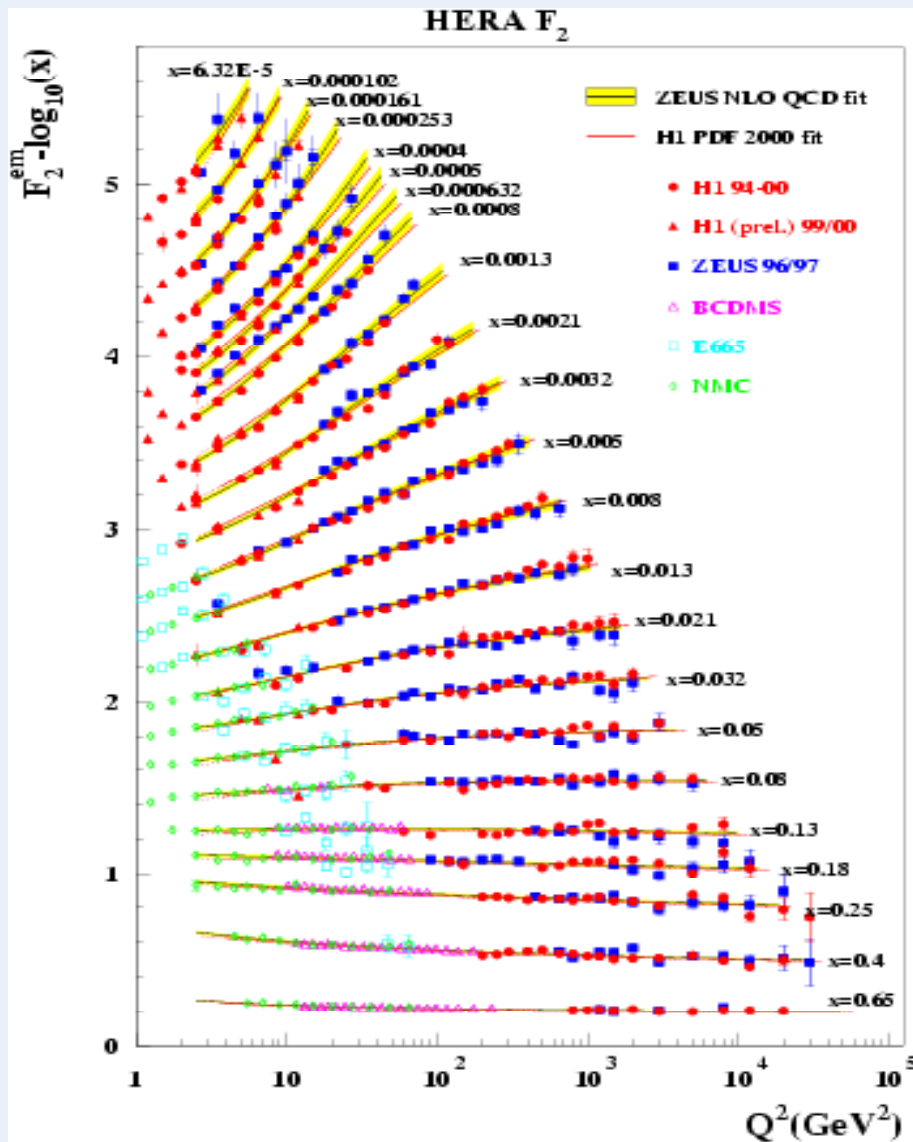

$$\frac{d}{d \ln Q^2} \begin{pmatrix} \Delta q \\ \Delta g \end{pmatrix} = \begin{pmatrix} \Delta P_{qq} & \Delta P_{qg} \\ \Delta P_{gq} & \Delta P_{gg} \end{pmatrix} \otimes \begin{pmatrix} \Delta q \\ \Delta g \end{pmatrix}$$

# Unpol. Cross Section and pQCD in pp

PHENIX  $pp \rightarrow \pi^0 X$   
PRD76, 051106

STAR:  $pp \rightarrow \text{jet} X$   
PRL 97, 252001

PHENIX  $pp \rightarrow \gamma X$   
PRL 98, 012002

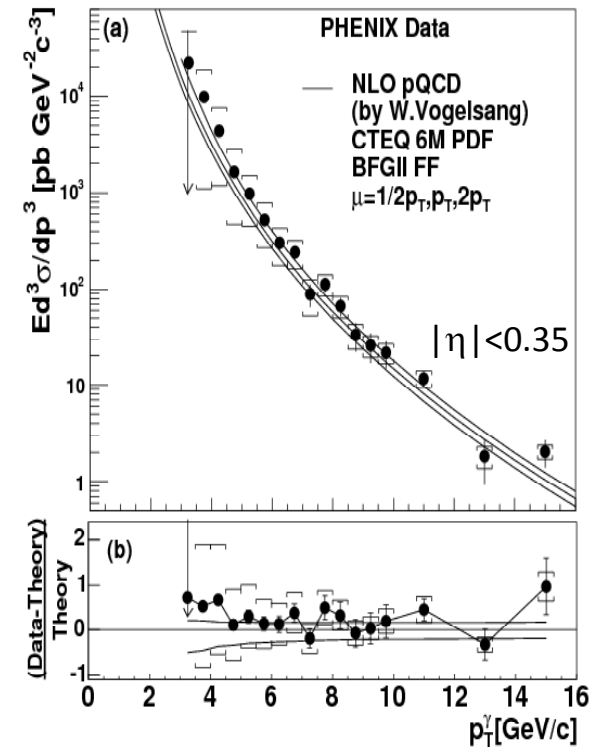
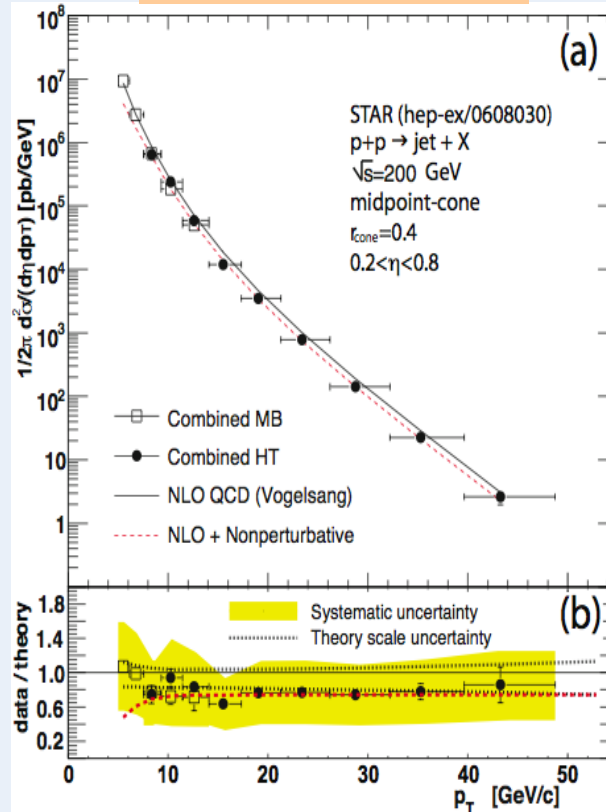
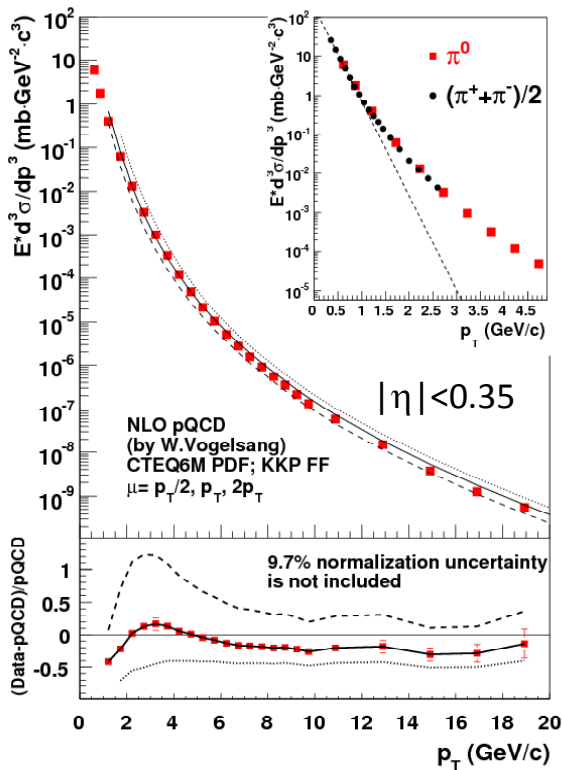

Good agreement between NLO pQCD calculations and data  $\Rightarrow$  pQCD can be used to extract spin dependent pdf's from RHIC data.

# Q<sup>2</sup> dependence

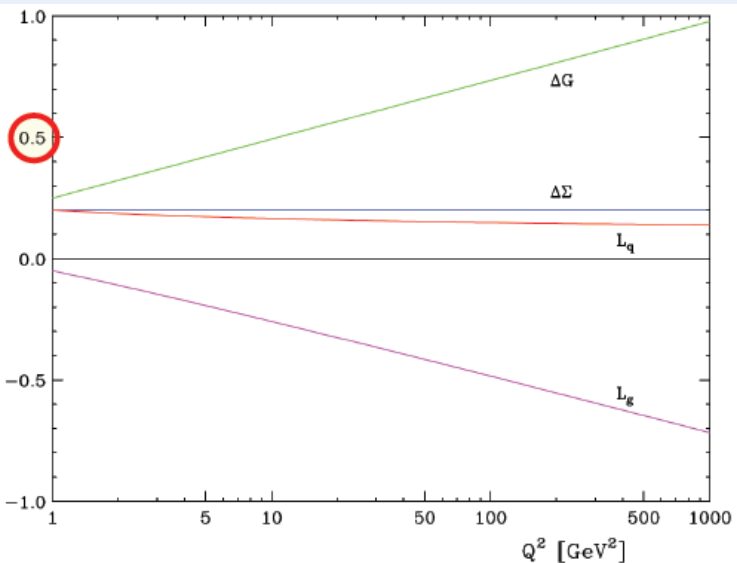

ΔG is dynamic value – Q<sup>2</sup> dependent  
 ΔG can be large at large Q<sup>2</sup> (and can be >>1/2) no matter how small it is at some low Q<sup>2</sup>  
 Large ΔG at large Q<sup>2</sup> is compensated by L<sub>g</sub>

$$\frac{1}{2} \text{proton} = \frac{1}{2} \Delta\Sigma + \Delta g + L_q + L_g$$

$$\frac{1}{2} \Delta\Sigma + L_q = \frac{1}{2} \frac{3n_f}{3n_f + 16} = 0.18$$

$$\Delta g + L_g = \frac{1}{2} \frac{16}{3n_f + 16} = 0.32$$