

OMEGA ROC ASICs for photodetectors

Salleh AHMAD, Sylvie BLIN, Stéphane CALLIER, Frederic DULUCQ, Julien FLEURY, Christophe de LA TAILLE, Gisèle MARTIN-CHASSARD, Ludovic RAUX
Nathalie SEGUIN-MOREAU, Damien THIENPONT, Jeanne TONGBONG

OMEGA microelectronics group
Ecole Polytechnique & CNRS IN2P3

<http://omega.in2p3.fr>

& WEEROC SAS

<http://weeroc.com>



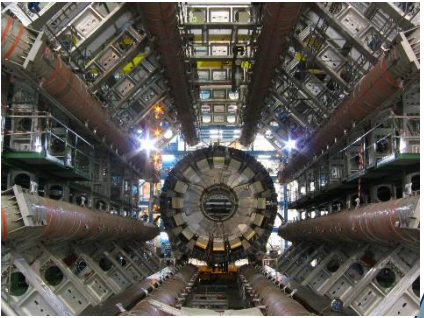

Research,
Institute

Education
School

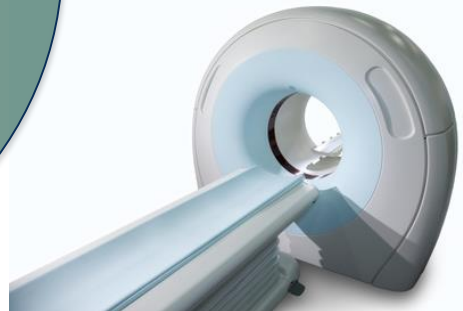

Industry, company

CdLT ROC chips ERDIT Stockholm

- Mutualized ASIC design team
- 10 research engineers (1 IR0, 2 IR1, 6 IR2, 1CDD), 2 pHD students
- Importance of critical mass for more and more complex circuits
- Cross-fertilization between projects
- Technology transfer via startup WEEROC

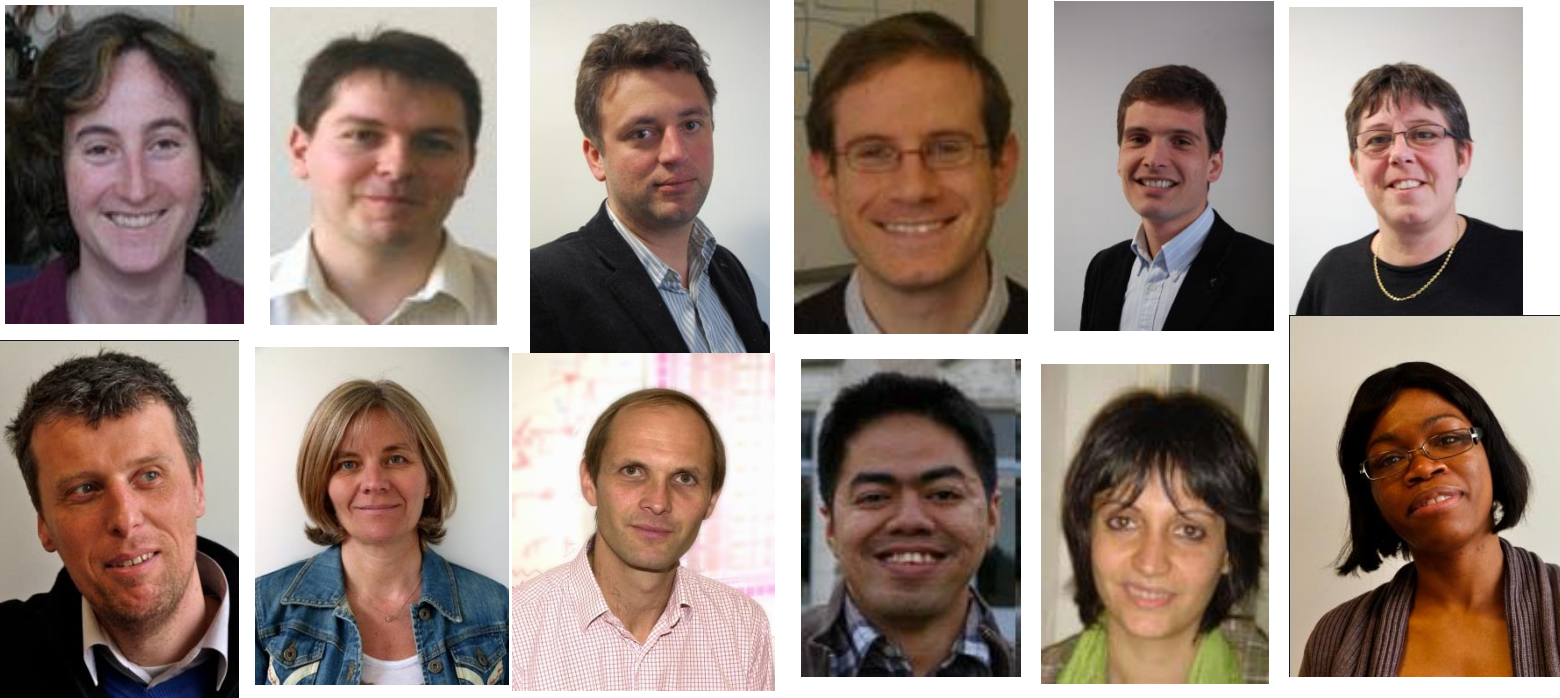

- Use of Silicon Germanium 0.35 μm BiCMOS technology since 2004
- Readout for MaPMT and SiPM for ILC calorimeters and other applications
- Very high level of integration : **System on Chip (SoC)**

Chip	detector	ch	DR (C)
MAROC	PMT	64	-2f-50p
SPIROC	SiPM	36	+10f-200p
SKIROC	Si	64	+0.3f-10p
HARDROC	RPC	64	-2f-10p
PARISROC	PM	16	-5f-50p
SPACIROC	PMT	64	-5f-15p
MICROROC	μMegas	64	-0.2f-0.5p
PETIROC	SiPM	32	50fC-300pC

<http://omega.in2p3.fr>

MAROC3

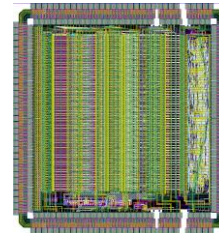

HARDROC2

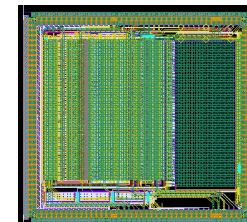

MICROROC1

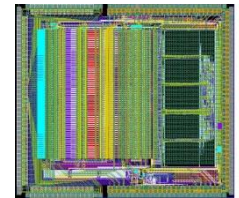

SKIROC2

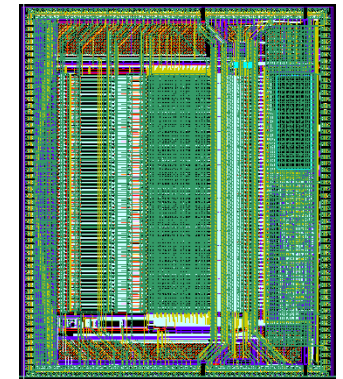

SPIROC2

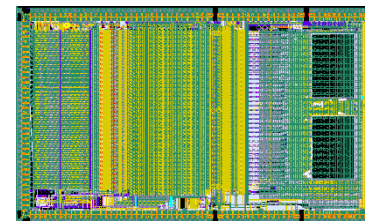

SPACIROC

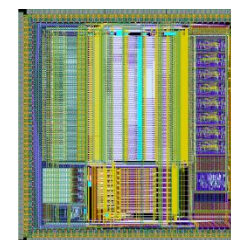

PARISROC2

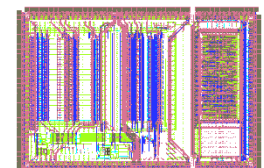

- MAROC
- SPACIROC
- PARISROC

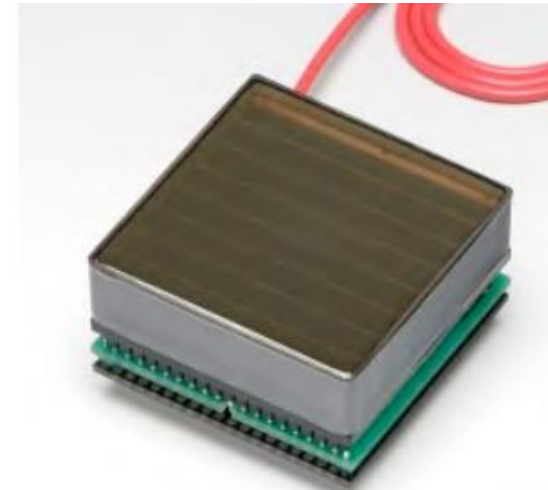

- Started with OPERA_ROC (2001)
 - 32 Channels in BiCMOS 0.8 μm
 - 3000 chips produced in 2002
 - Readout OPERA Target tracker in Gran Sasso
- MAROC1 (2004)
 - First prototype with 64 channels
 - AMS SiGe 0.35 μm (12 mm², Pw=5 mW/ch)
- MAROC2 (2006)
 - **1000 chips produced and bonded on a compact PCB for ATLAS luminometer (ALFA)**
- MAROC3 (2009)
 - Lower power dissipation
 - Wilkinson ADC added
 - 1000 chips produced in 2010
- Many applications: Double-Chooz, Menphyno, medical imaging(Valencia, ISS Roma)...

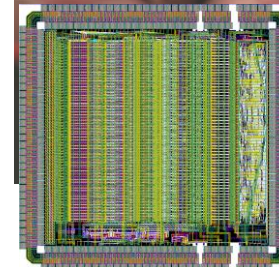
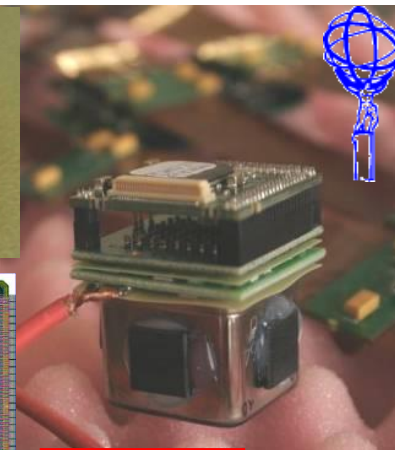
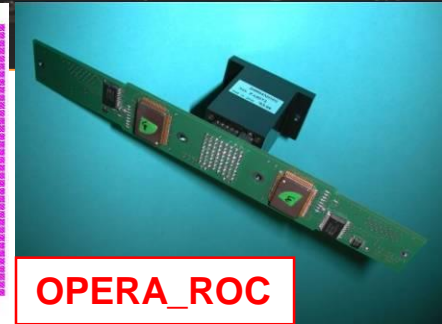
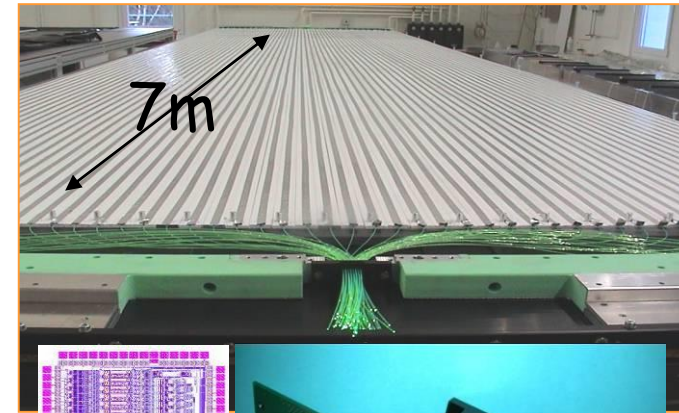

MAROC2

MAROC3 : MultiAnode Read-Out Chip



- Complete front-end chip for 64 channels multi-anode photomultipliers
 - 6bit-individual gain correction
 - Auto-trigger on 1/3 p.e. at 10 MHz
 - 12 bit charge output with internal ADC
 - SiGe 0.35 μm , 12 mm^2 , Pd = 5 mW/ch

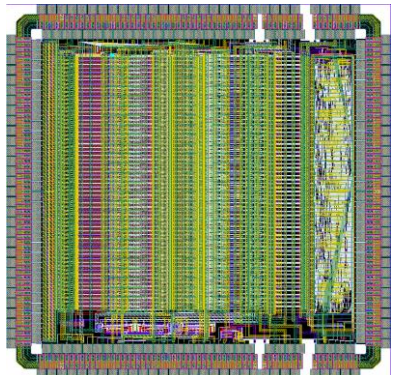
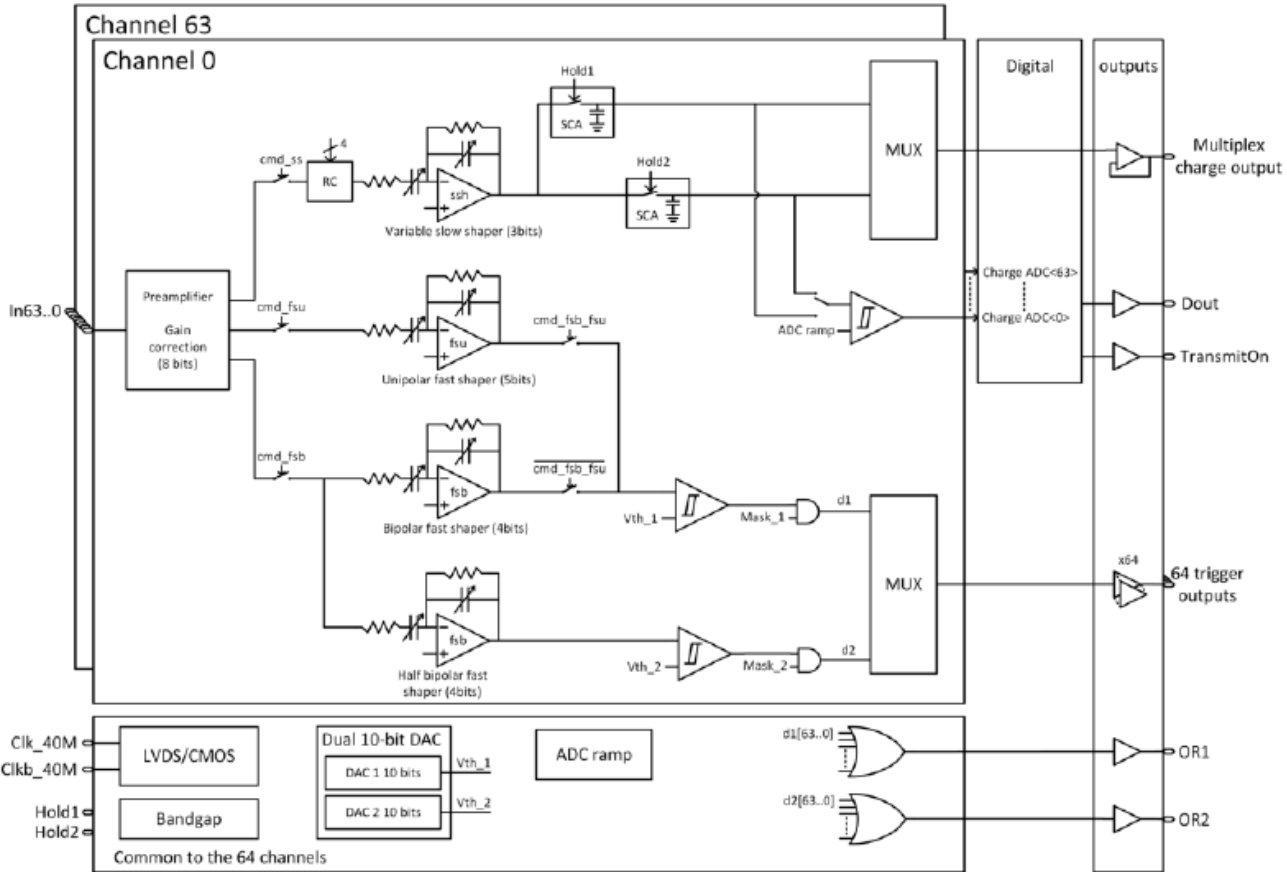

1 MUX charge output

AMS SiGe 0.35 μ m
Package: CQFP240
Area: 16 mm²

64 PM inputs

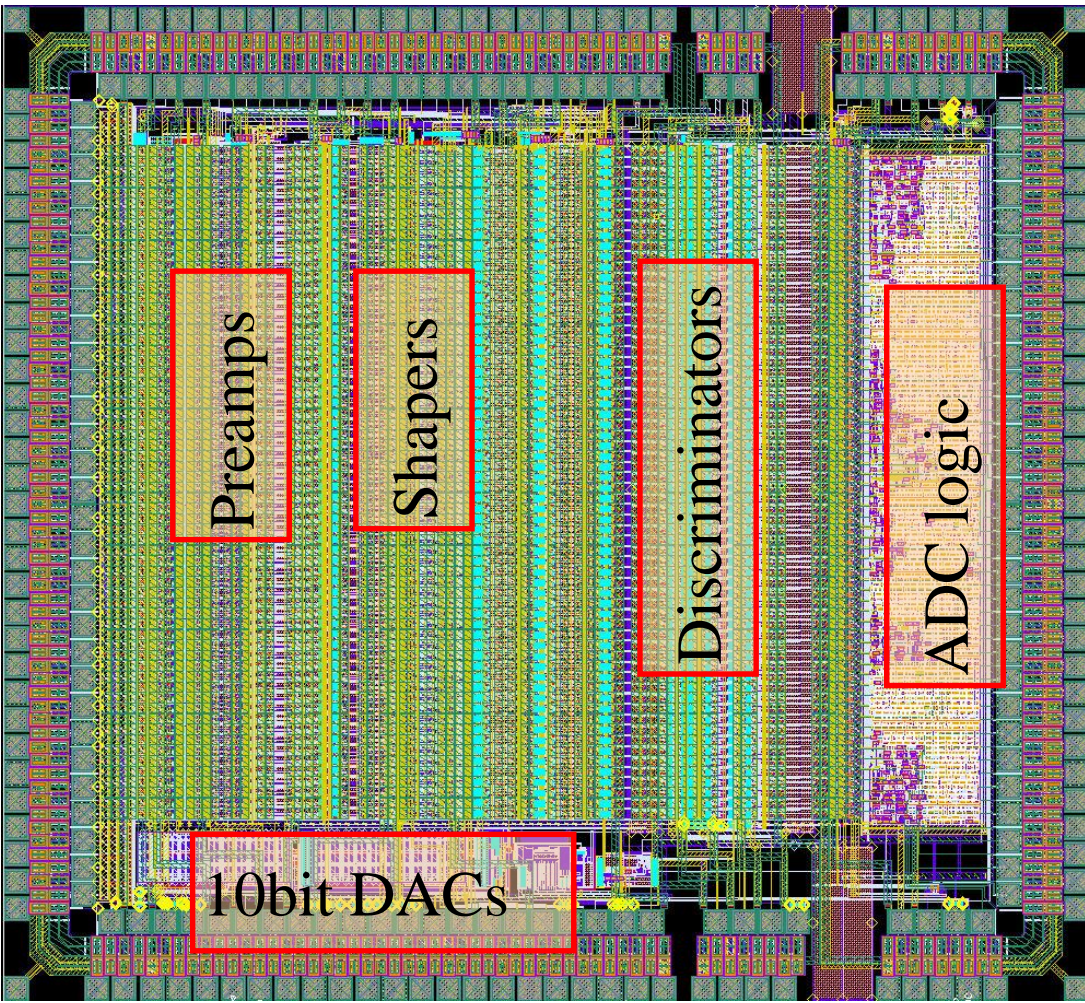

64 trigger outputs

2 Fast OR outputs

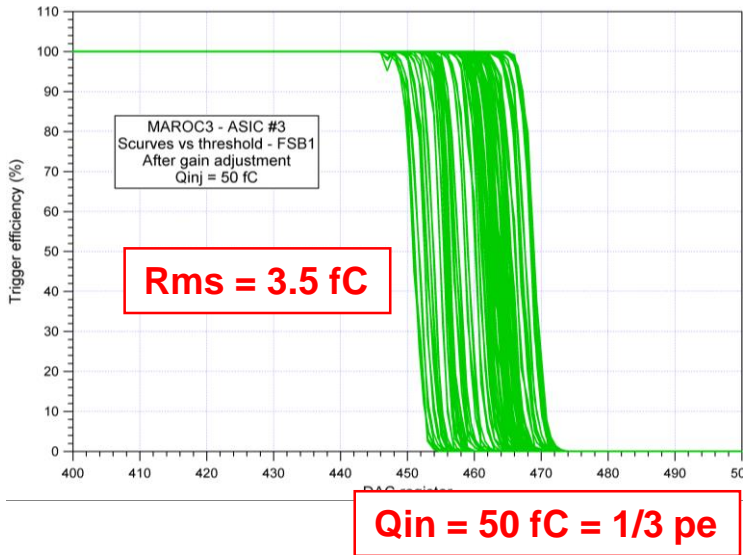

Jitter (ps rms)

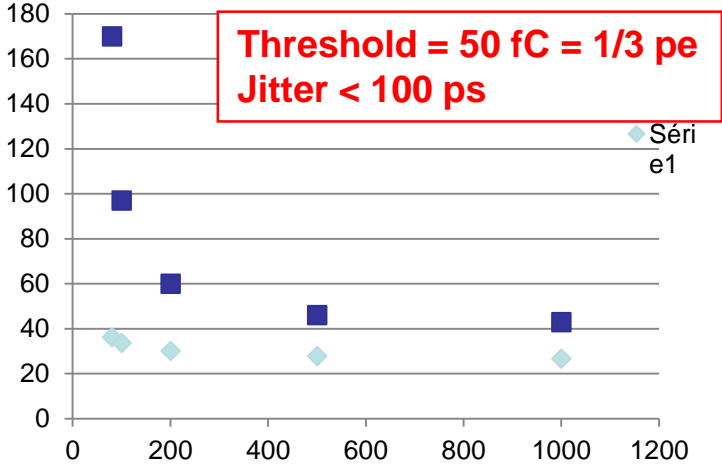

Time walk (ns)

Input charge (fC)

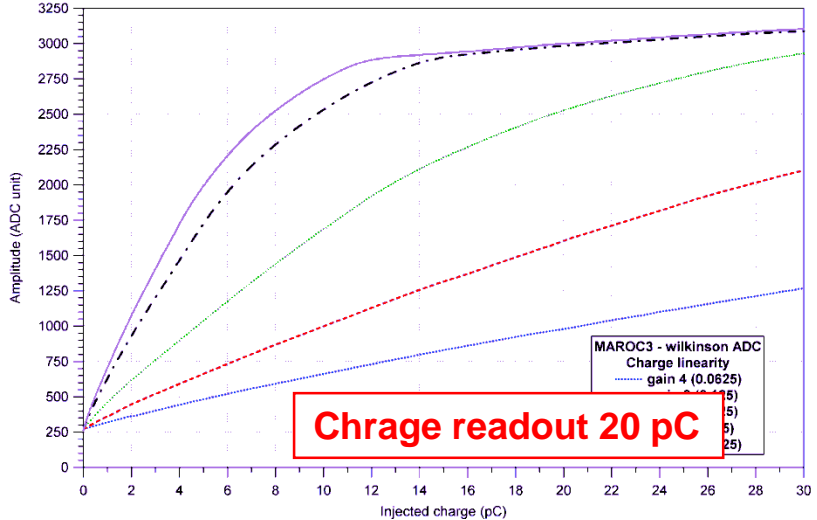
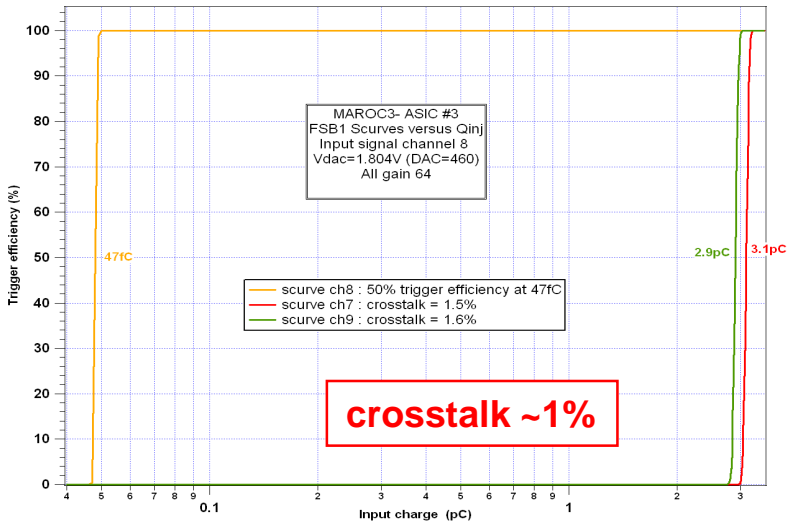

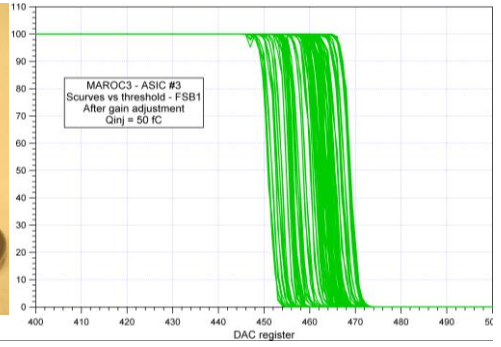
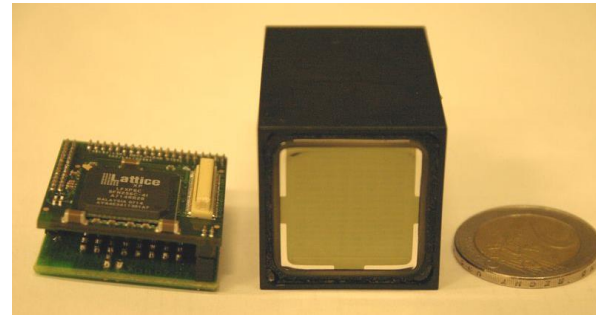
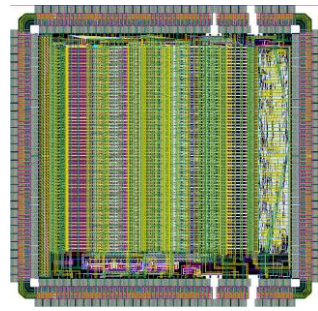

2012-2013	
Ralf ENGELS	Allemagne/Juelich
Vladimir SOLOVOV	Portugal/ Coimbra
Scott Lumsden	UK/Glasgow
JJ Velthuis	UK/Bristol
Piero Giorgio FALLICA/ ST micro	Italie/ Catania
Vincent TATISCHEFF	France/Orsay
Alexander Nadeev	Russie
Domenico Lo Pesti	Italy/Catania
E.L. Rizzini	Suisse/Genève
D. Lo Presti	Italie/ Catania
P. Rodrigues	Portugal/Lisboa
Stephen Wotton	Suisse/Genève
JJ Velthuis	UK/Bristol
Riccardo Faccini	Italie/Roma
Patrizia Rossi	Italie/Frascati
Sima Cristina	Roumanie/Magurele
Patrizia Rossi	Italie/Frascati
D.Cussans/P.Baesso	UK/Bristol
Paolo Baesso	UK/Bristol

Alain Blondel	Suisse/Genève
Pedro Rodriguez	Portugal / Lisboa
William Brooks	Chili / Valparaiso
Stephane Colonges	France / Paris
Evandro Lodi Rizzini	Suisse / Genève
Günter Kemmerling	Allemagne/Juelich
Thomas Schweizer	Allemagne/Munich
Jason Legere	USA / Durham
Evandro Lodi Rizzini	Suisse / Genève
Ronan Oger	France / Paris
Erik Vallazza	Suisse / Genève
Daniel Bertrand	Belgique / Bruxelles
Ronan Oger	France / Paris
Jason Legere	USA / Durham
Tanushyam Bhattcharjee	Kolkota/Inde
Vincent Tatischev	France / Orsay

Gabriela Liosa	Espagne / Valence
Pierre Salin	Sofia Antipolis/France
Prof. A.A.Petrukhin	Russie/Moscou
Erik Vallazza	Suisse / Genève
Riccardo Faccini	Roma/Italie
Pierre Salin	Sofia Antipolis/France

ATLAS lumi : 500chips (LAL)
Double Chooz : 1000 (Nevis)
CLAS12 RICH (INFN)
LHCb RICH ? (CERN)
JUNO Veto (IPHC)

John Parsons	USA
Bernard Genolini	France / Orsay
Nicoleta Dinu	France / Orsay
JJ Jaeger	France / Paris
Vincent Tatischev	France / Orsay

Variant : SPACIROC for JEM-EUSO



- JEM-EUSO (JAXA)
 - Cosmic ray imaging from ISS
- EUSO balloon (CNES)
 - Test flight 25/8/14
- TA experiment (UTAH)

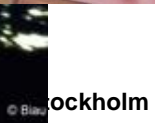
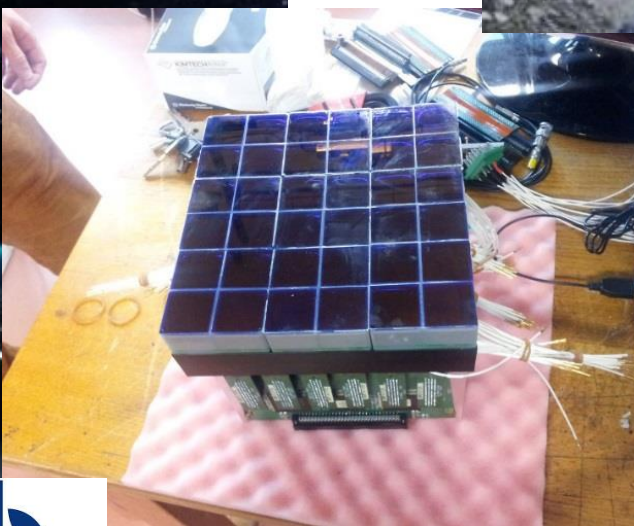
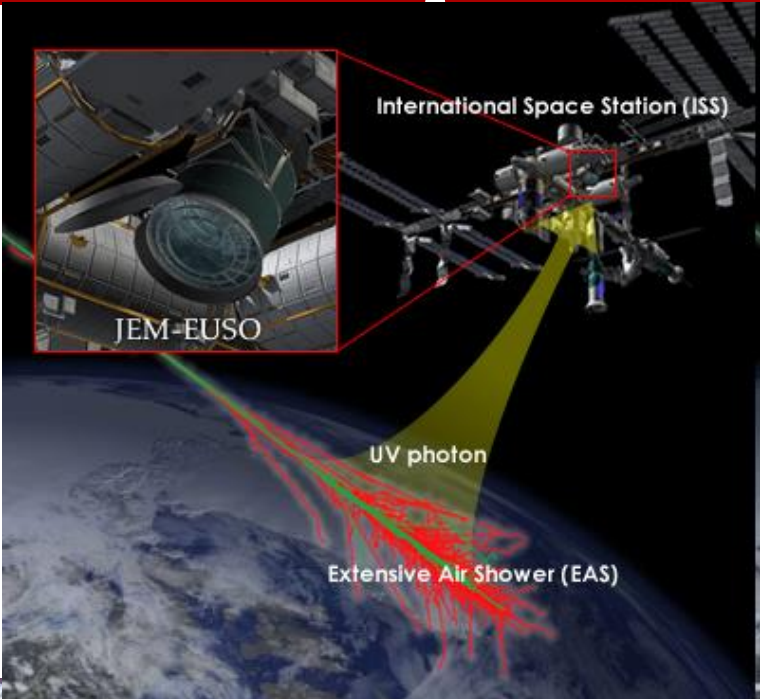

- 100 MHz Photon counting for JEM-EUSO
- 64 ch radtol MaPMT readout
- Pd < 1 mW/ch

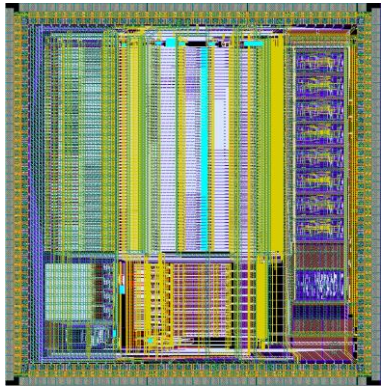
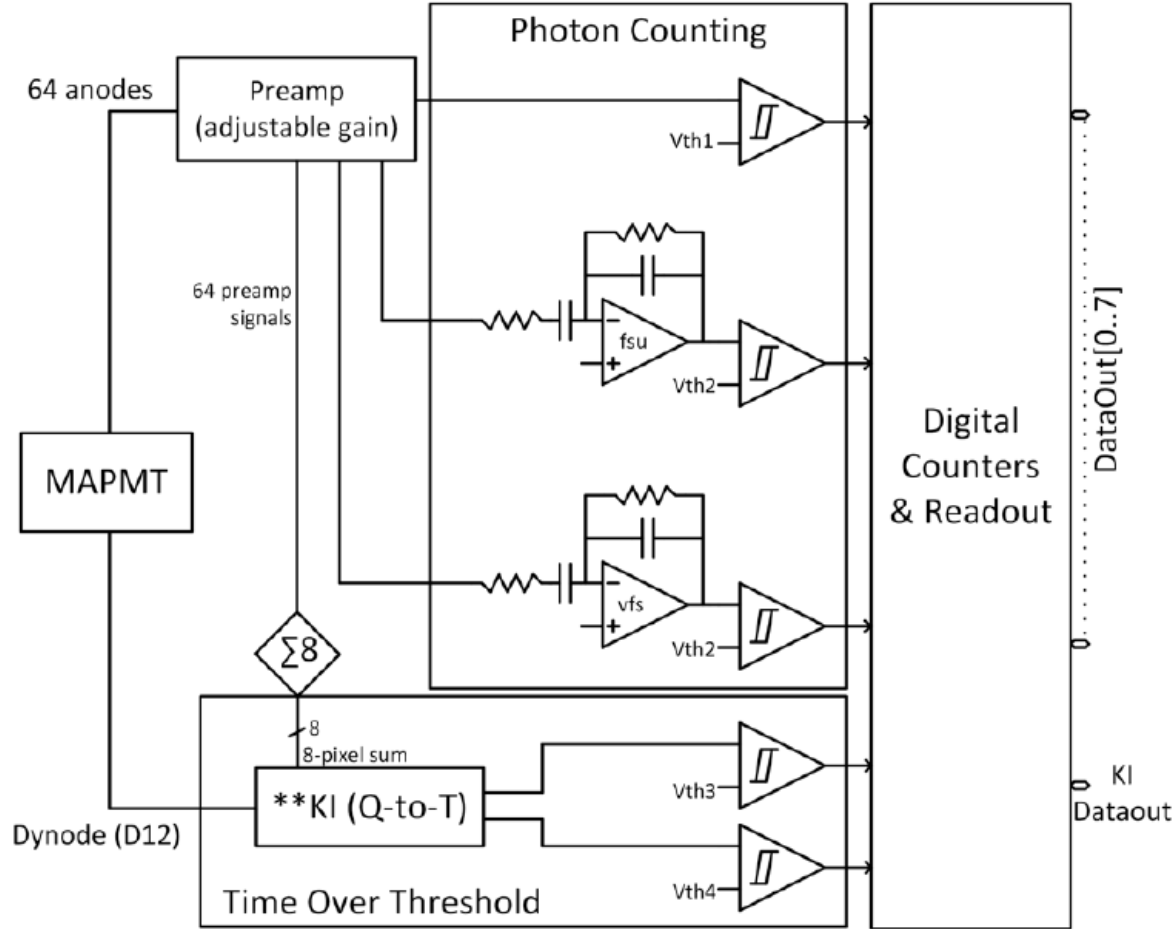

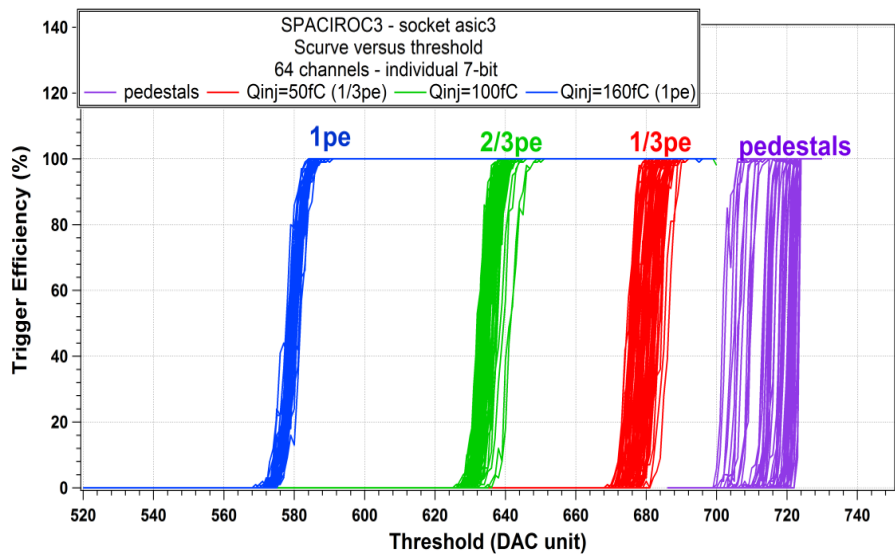
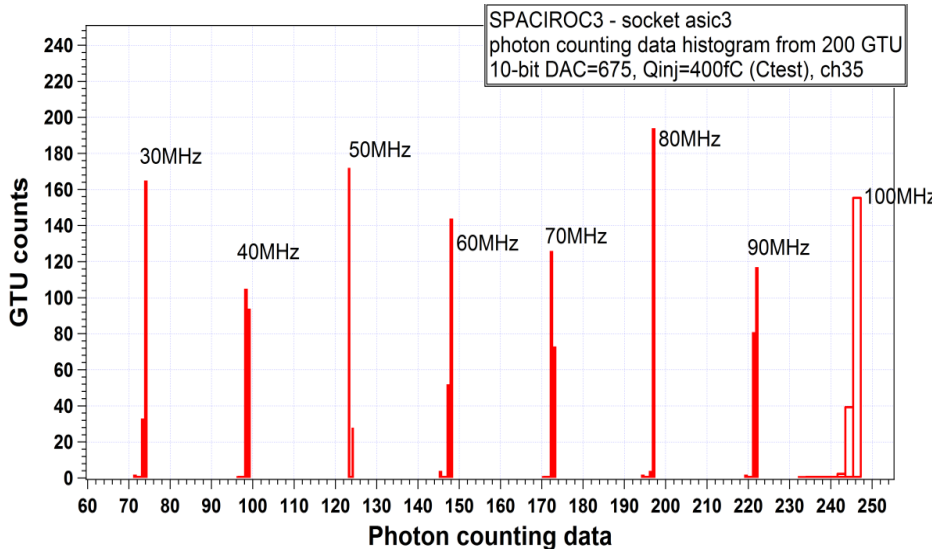
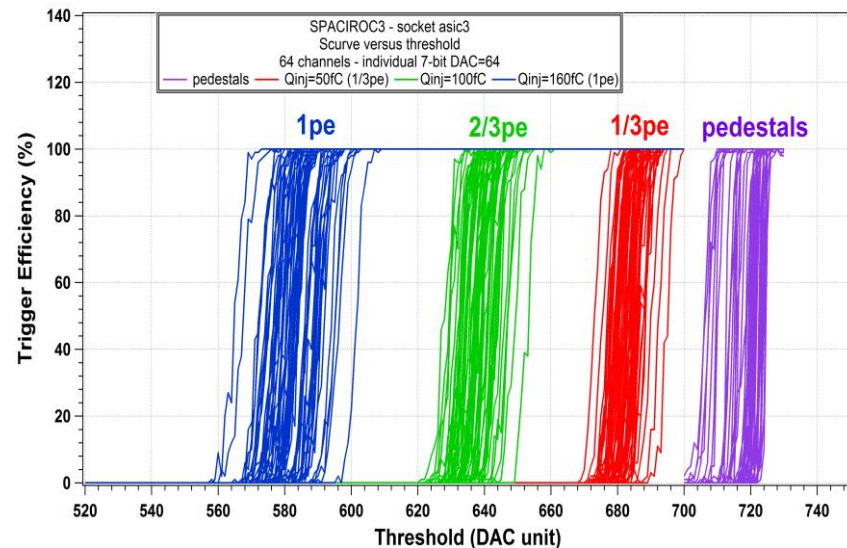
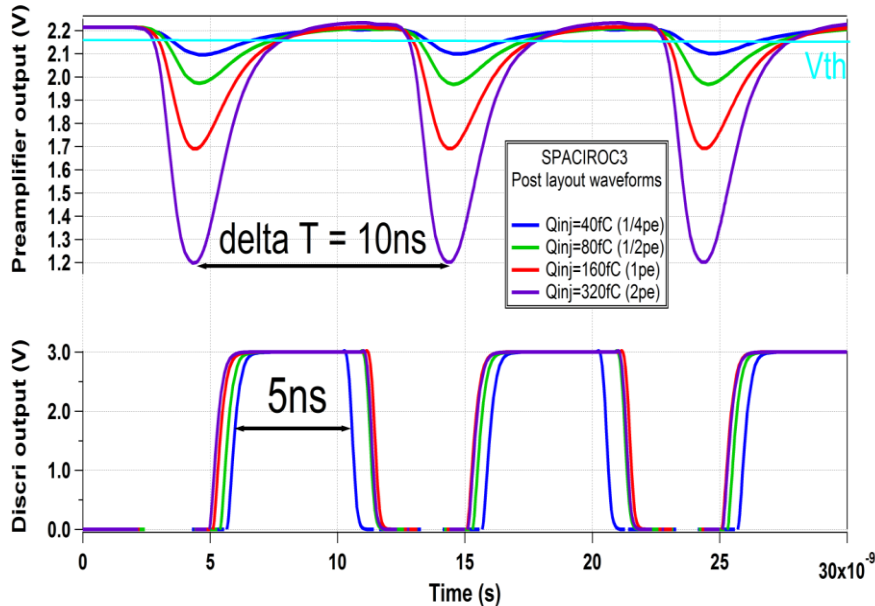

- Photomultiplier ARray Integrated SiGe ROC
 - « Large area PMT array » with centralized ASIC
 - Auto-trigger at 1/3 p.e.
 - Charge and time measurement (10-12 bits)
 - Data driven : « One cheap wire out »

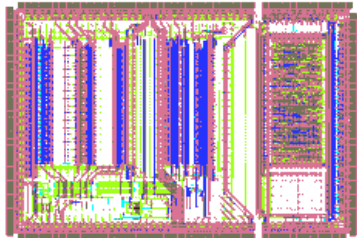
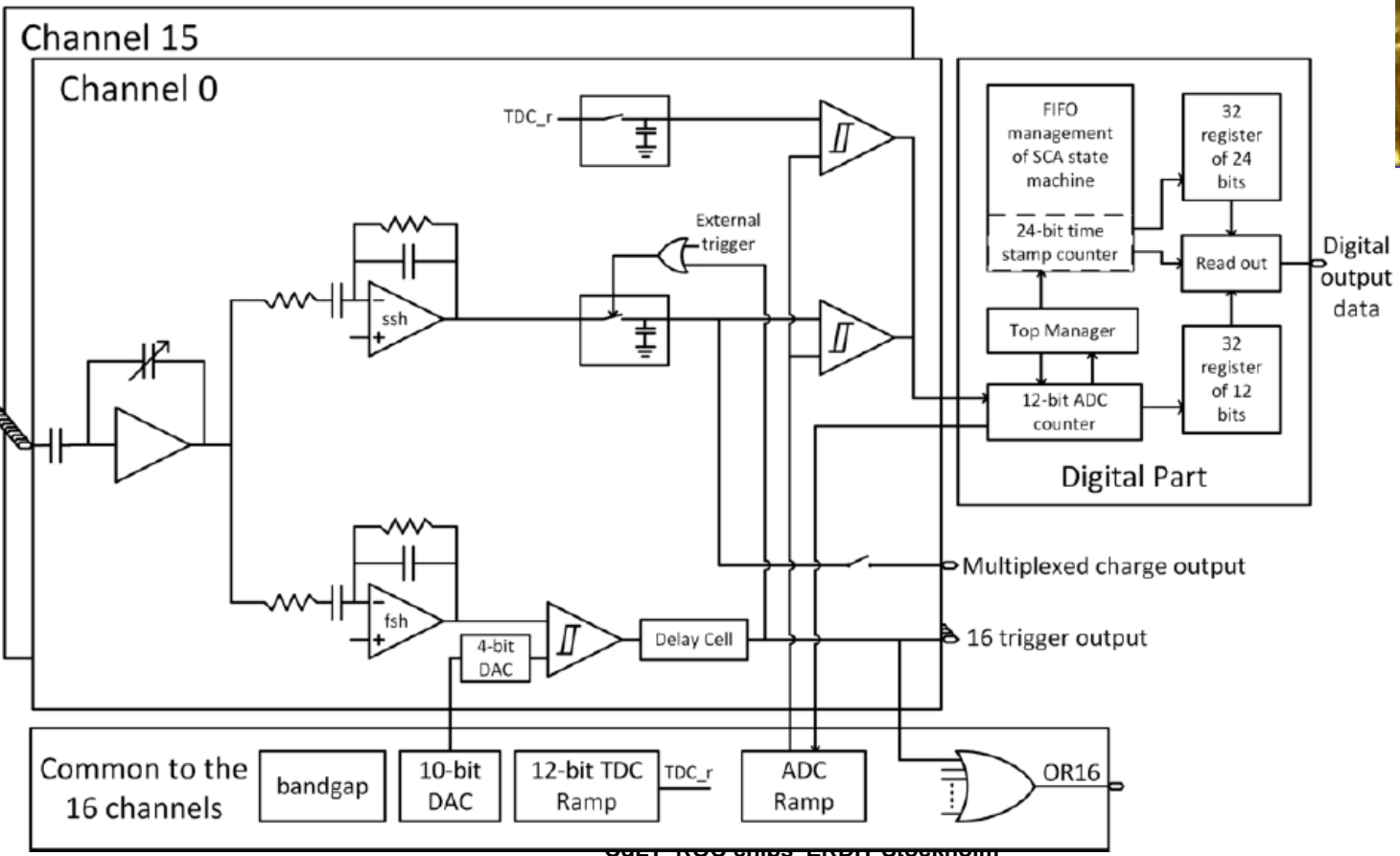
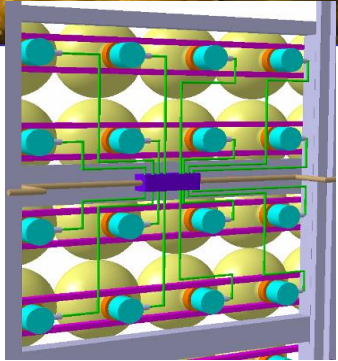

- Next generation large area photomultipliers
 - Replace large PMTs by arrays of smaller ones (PMm² project)
 - Centralized ASIC 16 independent channels
 - Data driven : zero suppressed digital output
 - Single photoelectron sensitive, 100 ps timing

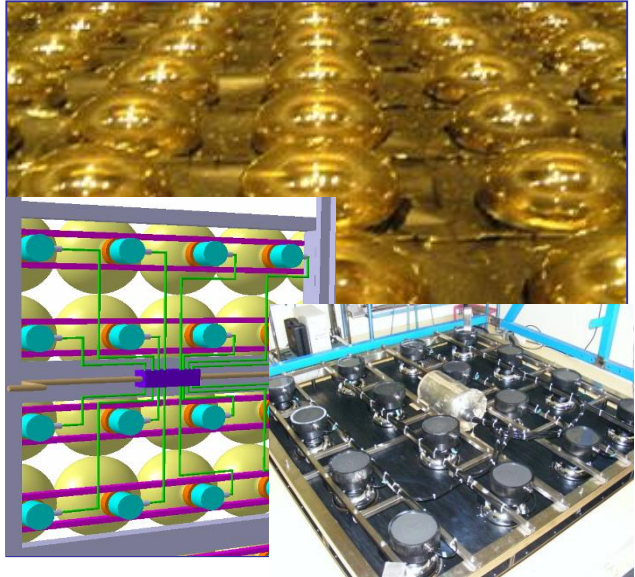

Micro-TCA crates for charge signal acquisition electronics



Large scale demonstrator with 7680 electronic channels in liquid Argon

© Tomas Patzak,
Margherita Buizza
APC, Paris, France

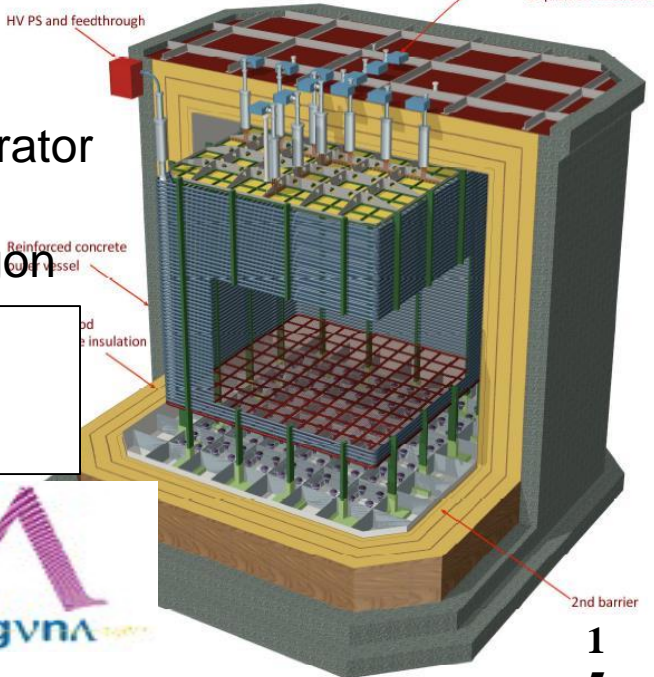

© Tiina Suomijarvi, Yingtao Chen IPN, Orsay



PARISROC2 chip

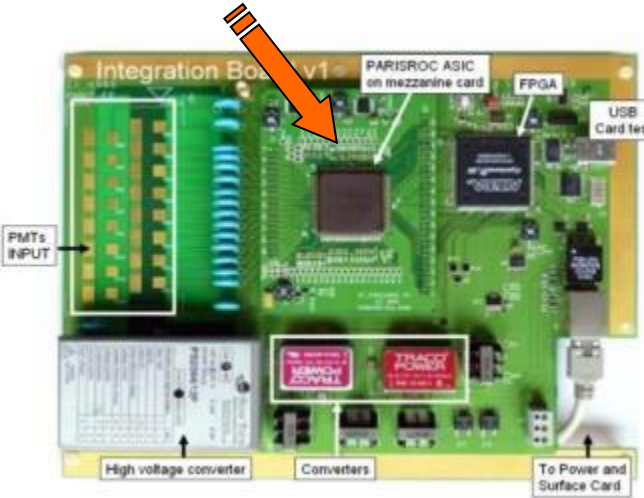

Watertight box



2m x 2m array



1-in (XP3102) single p.e. noise spectrum.

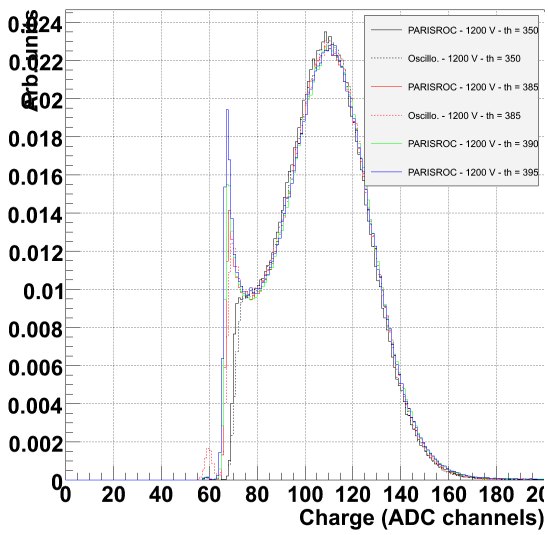

8-in (Hamamatsu R5912) Single p.e. noise spectrum.

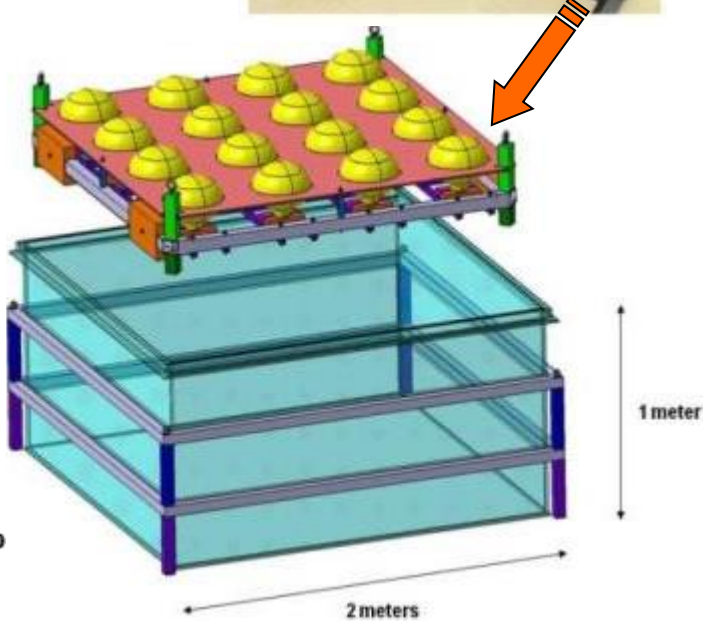
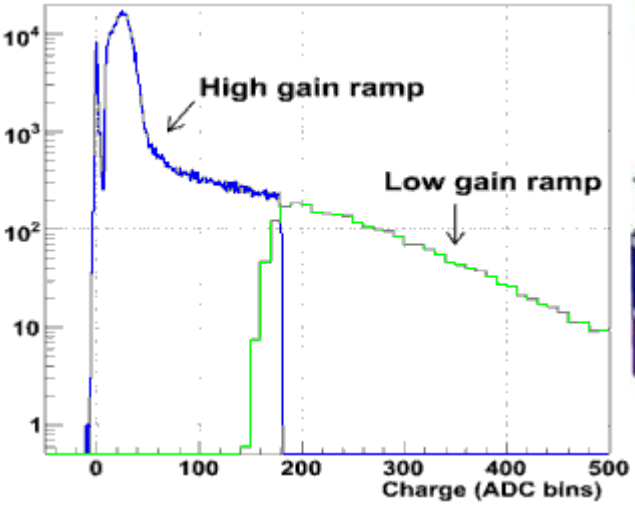

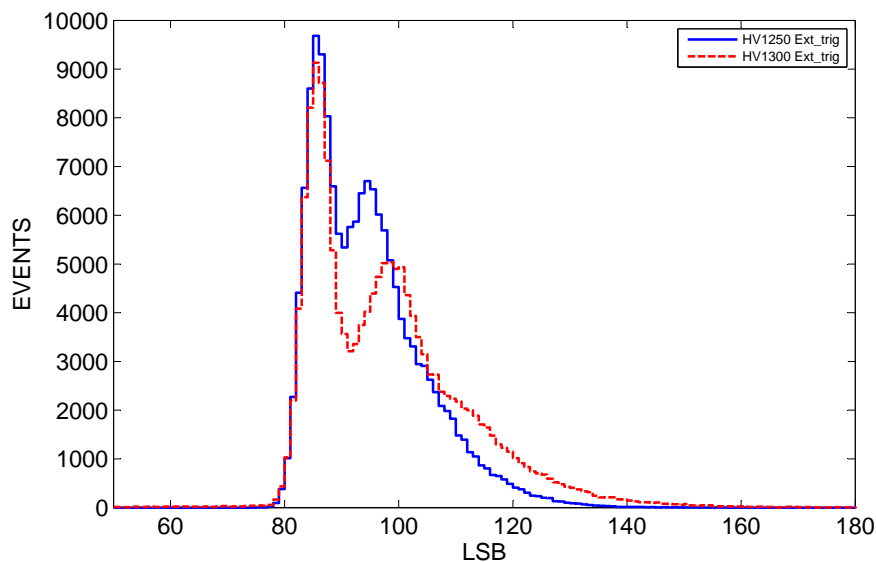
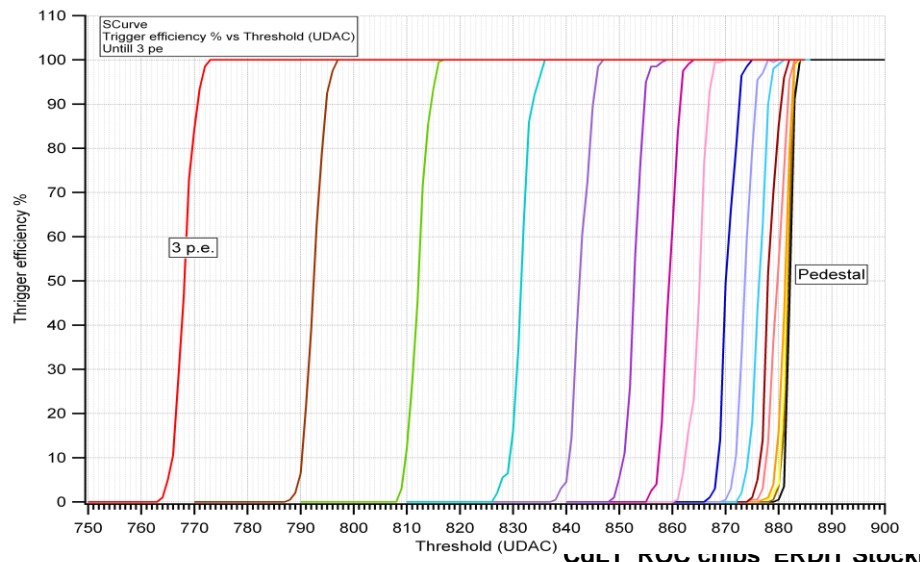
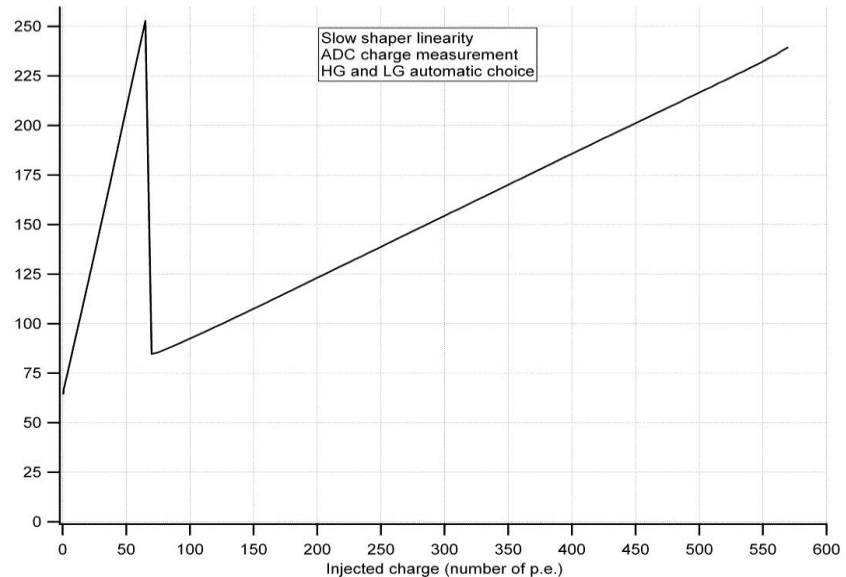
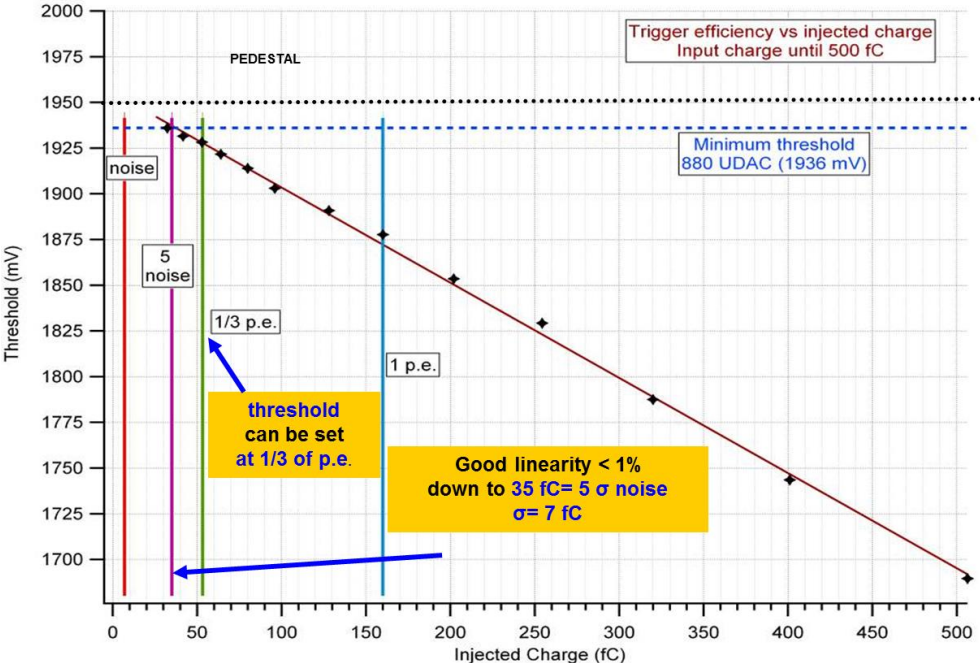

- SPIROC
- EASIROC/CITIROC
- PETIROC
- TRIROC

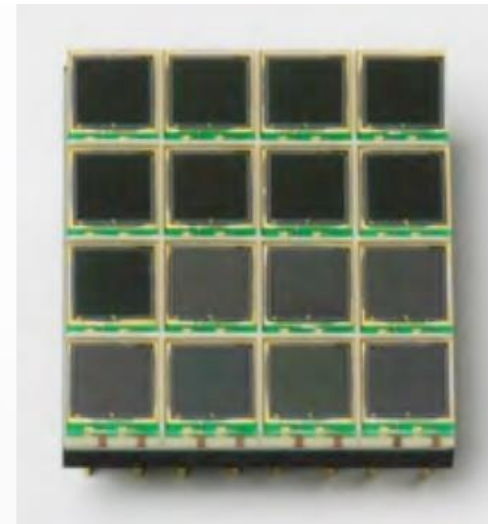
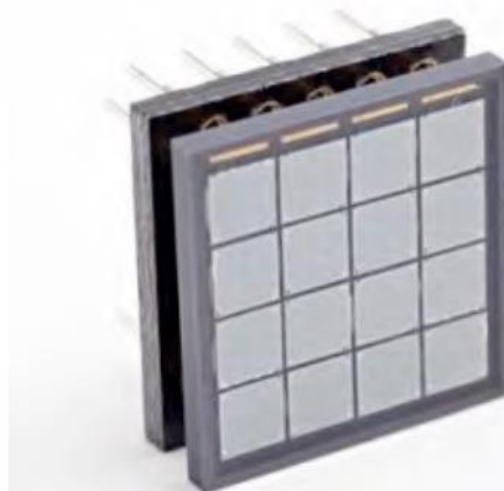
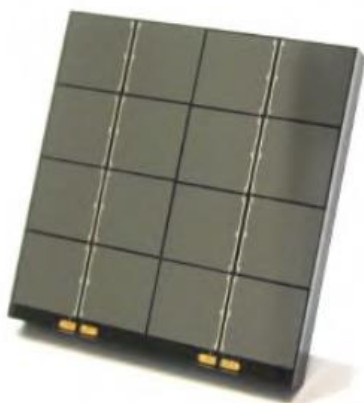

- **FLC_SiPM** designed and produced to equip **the Analog H-Cal physics prototype** for the ILC in 2005 (1 cubic meter, 38 layers, 2cm steel plates, 8000 tiles with SiPM)
 - 1st ASIC to readout SiPM
- **SPIROC** developed in November 2007 to equip the CALICE **AHCAL** and **ECAL** EUDET technological prototypes
- **Variants of SPIROC: EASIROC** designed in September 2009, **CITIROC** in 2013
 - EASIROC/CITIROC : “light” analog version of SPIROC for SiPM users who don’t need the ILC specific digital core
- **Others applications using SPIROC/EASIROC/CITIROC chips for SiPM readout**
 - Astrophysics: PEBS experiment (Aachen University), CTA
 - Medical imaging (Roma, Pisa, INMC Orsay, Valencia, etc.)
 - Nuclear physics: E40 experiment (KEK)
 - Volcanology: MuRay muon radiography of geological structures (INFN Napoli)
- **Dedicated chip for fast timing and high timing resolution applications**
 - **PETIROC** (November 2013)
 - **TRIROC** (March 2014) “FP7” project

- SPIROC : Silicon Photomultiplier Integrated Readout Chip
 - Developed to read out the analog hadronic calorimeter for CALICE (ILC)
 - DESY collaboration (EUDET project)
 - Chip embedded in detector : **low power !**
- 36 channels autotrigger 15bit readout
 - Energy measurement : 15 bits in 2 gains
 - Autotrigger down to $\frac{1}{2}$ p.e.
 - Time measurement to ~ 1 ns
 - Power dissipation : $25\mu\text{W}/\text{ch}$ (power pulsed)

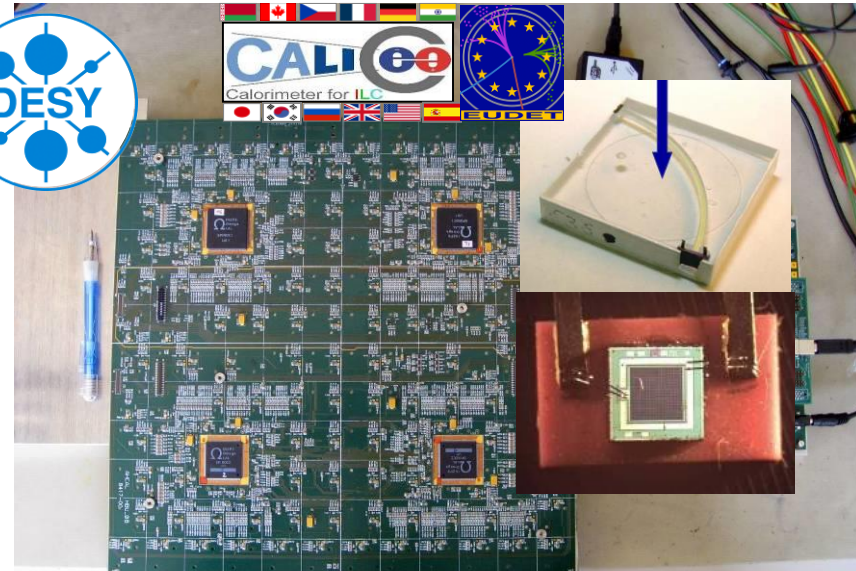

(0.36m)² Tiles + SiPM + SPIROC (144ch)

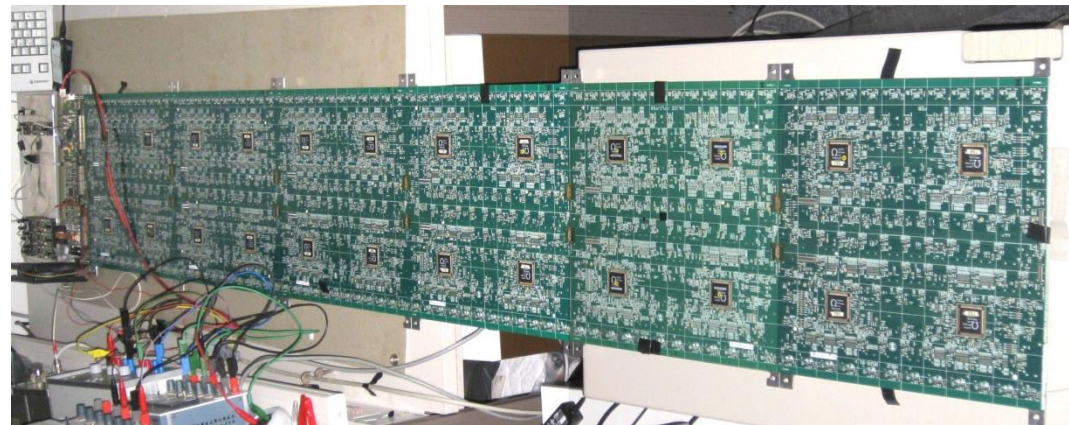
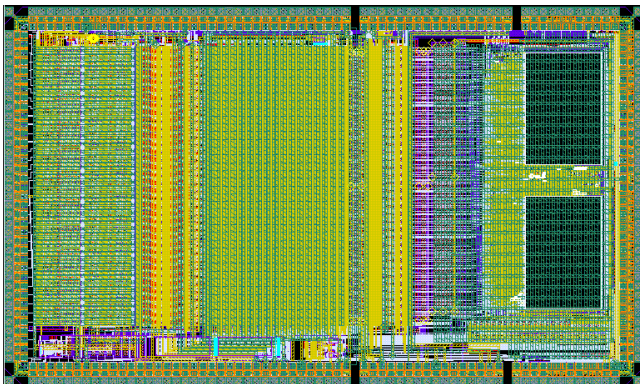

SPIROC : System On Chip

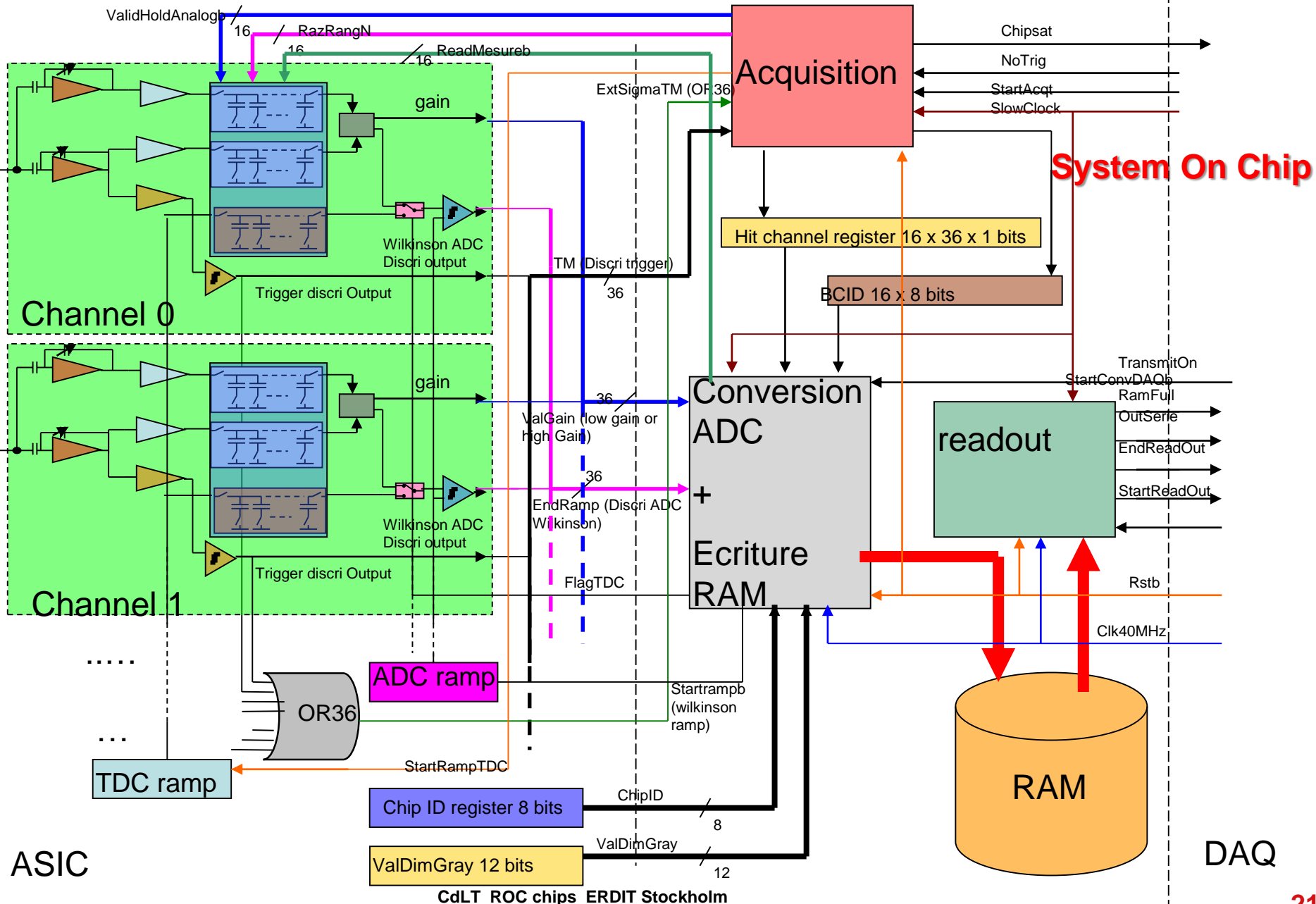

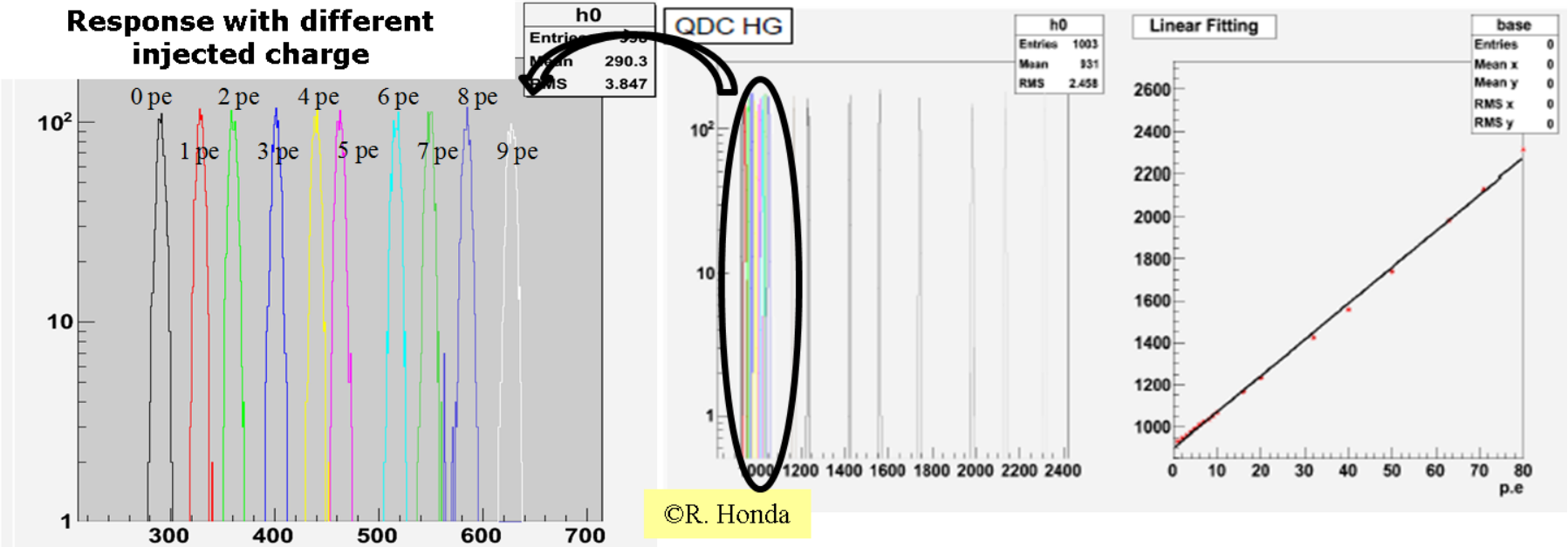

36-channel S-curves: trigger efficiency versus threshold (1 LSB = 2 mV)

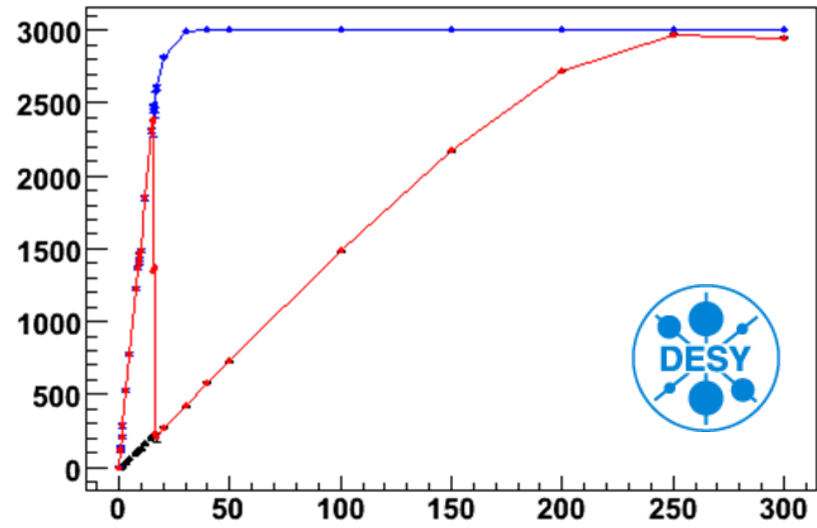
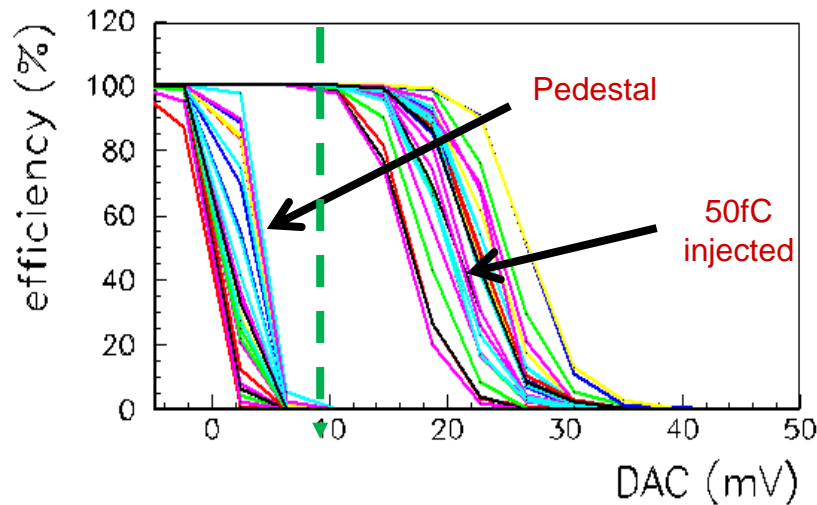

SiPM SPECTRUM with Autotrigger

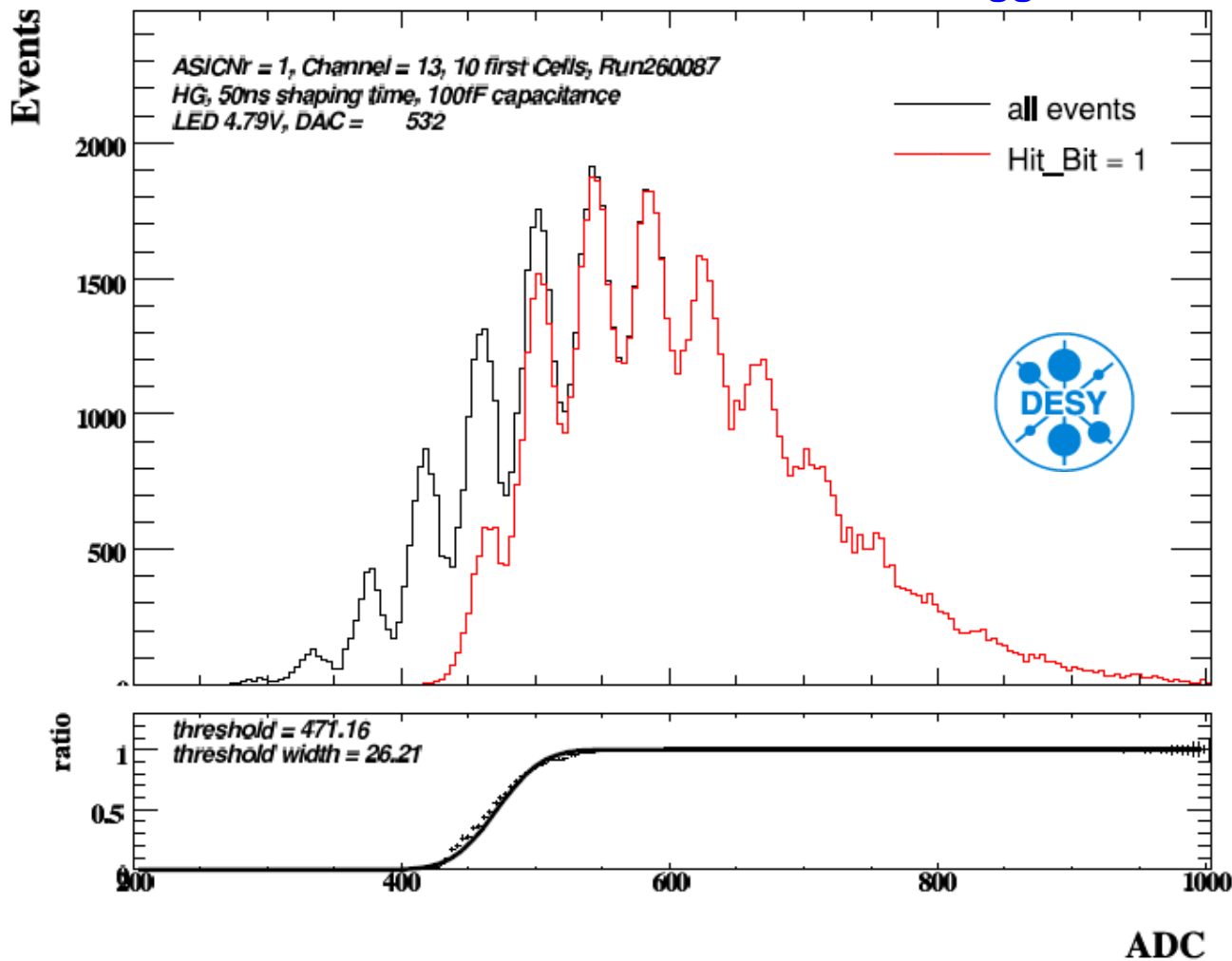

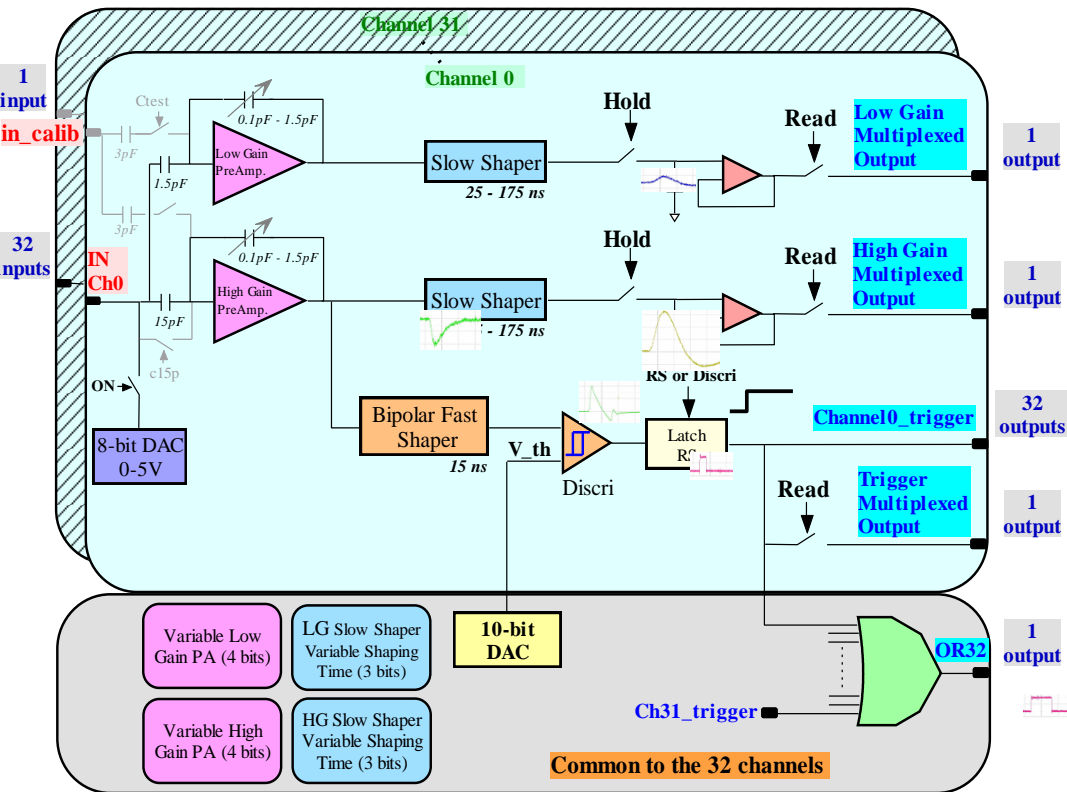

- 32-channel front-end readout (analogue part of SPIROC)
 - 2 multiplexed analog outputs (high gain, low gain) [tri state outputs]
- Trigger output
 - 32 Trigger outputs
 - OR32 output
 - Trigger multiplexed output (latch included) [Tri state output]
- Low power : **4.84 mW/channel**, 155 mW/chip

SipMed, IMNC, LAL, OMEGA

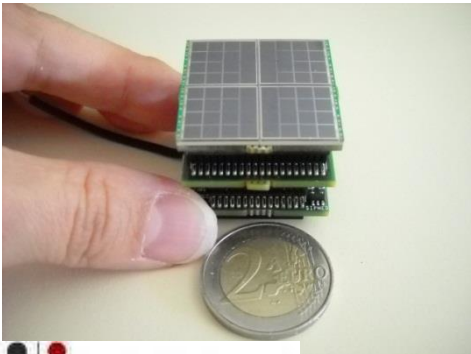
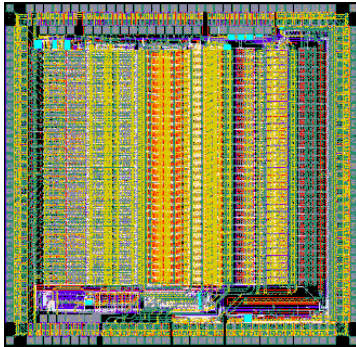
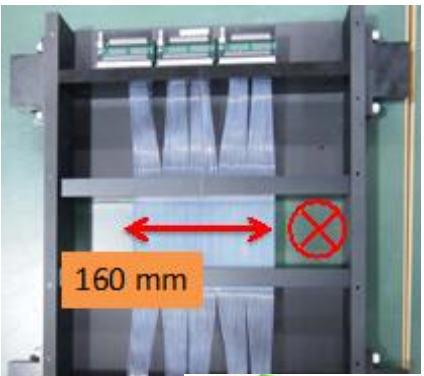

The "Shadow" of the Vesuvius

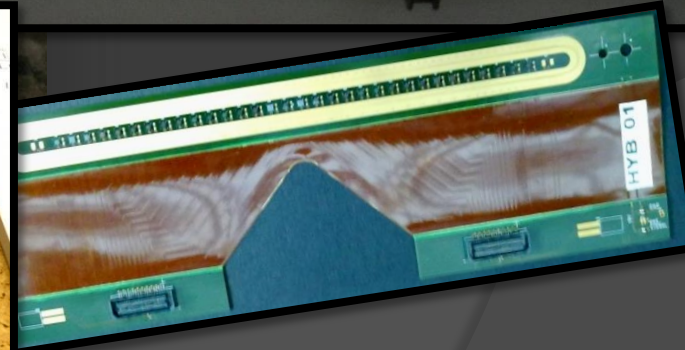
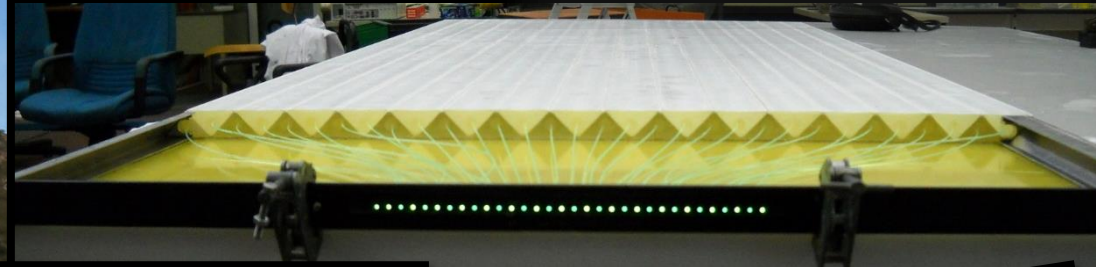
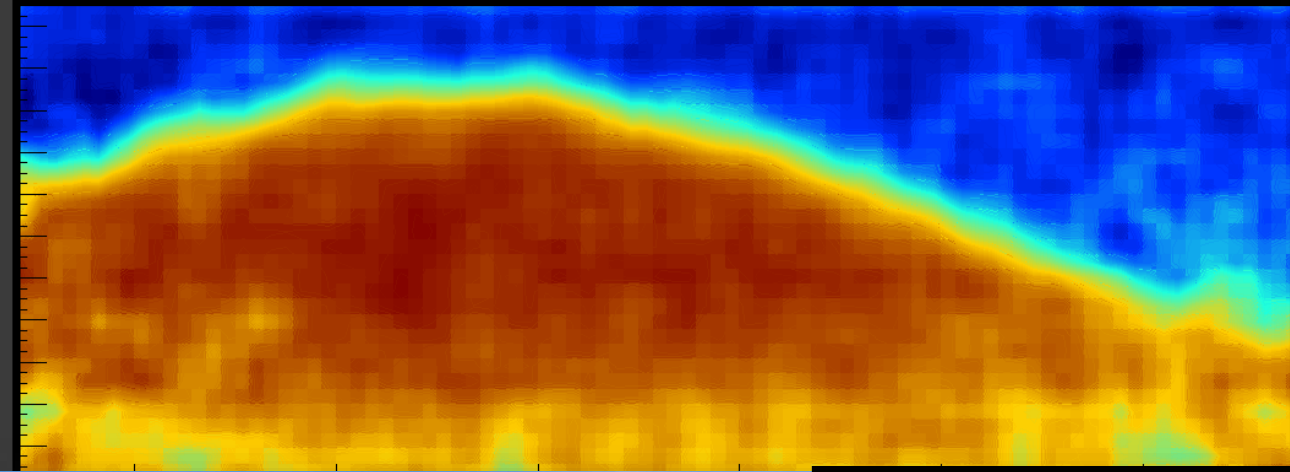

© P. Strolin INFN Napoli



weeroc

- Evolution of EASIROC 32 ch SiPM readout
 - 32 channels, positive input, 5V input DAC HV adjustment
 - 32 trigger outputs & High Gain / Low gain multiplexed charge output
 - Peak detector and two trigger level (timing & energy)
 - Gain adjustment per channel (6 bits)

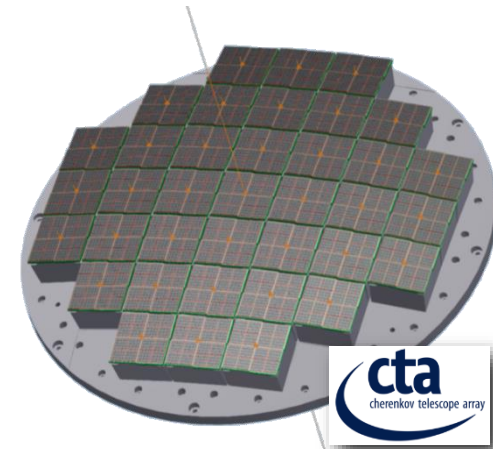
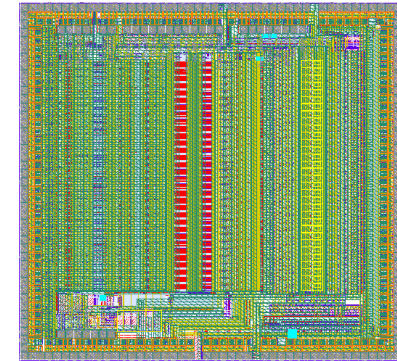
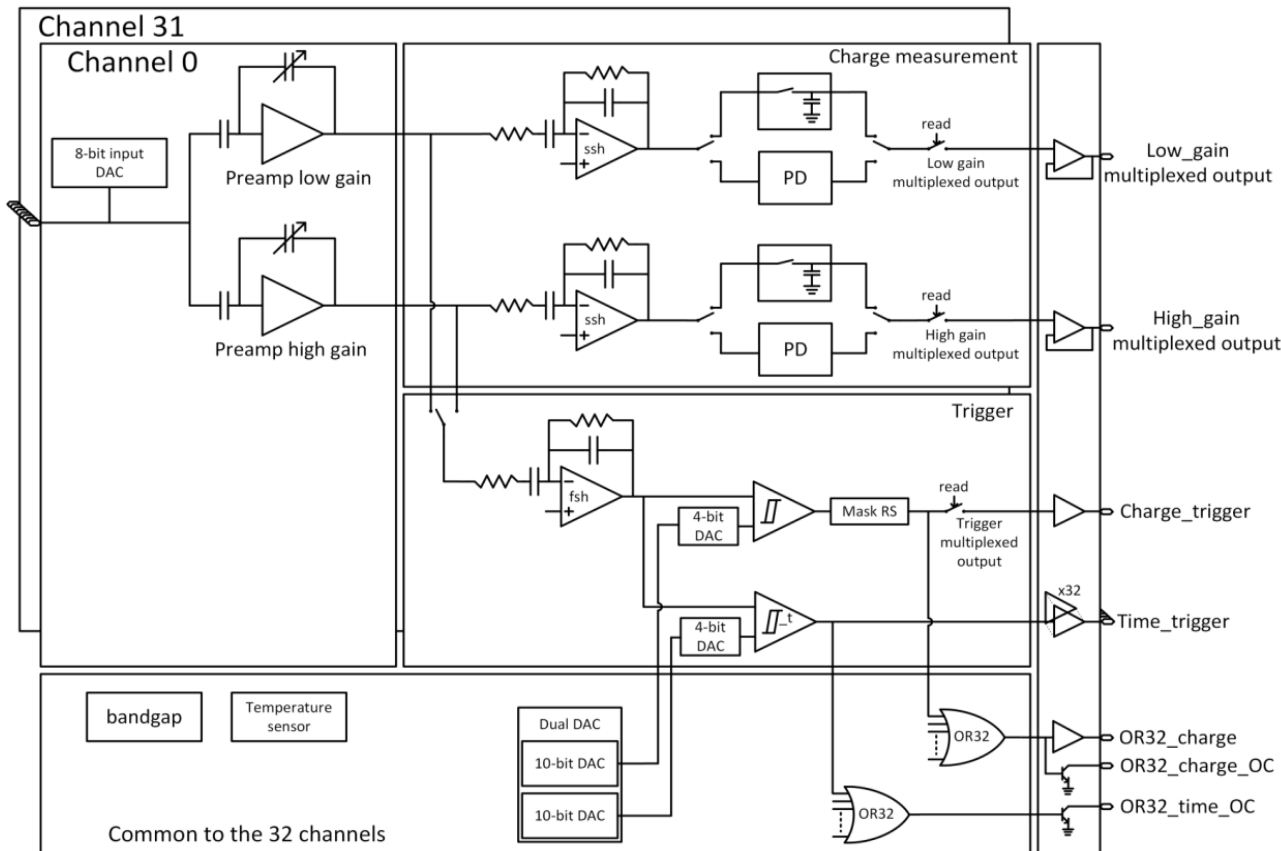

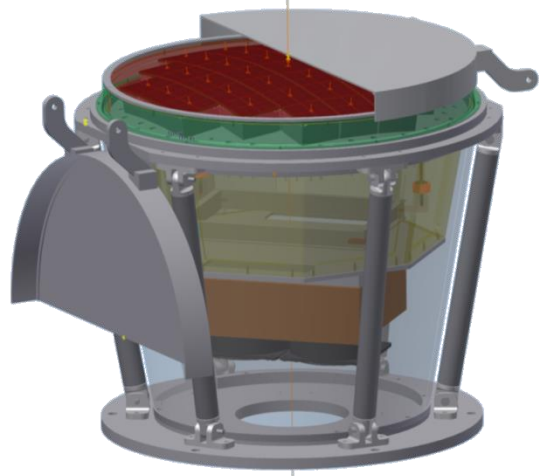

FOV = 9.6°
Ø = 350mm

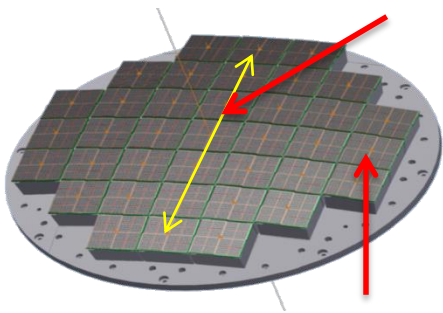

Photon Detection Module (PDM)
Pixel = 0.17° → 6.2 x 6.2 mm

© O. Cataneo INAF Palermo

ASSEMBLING

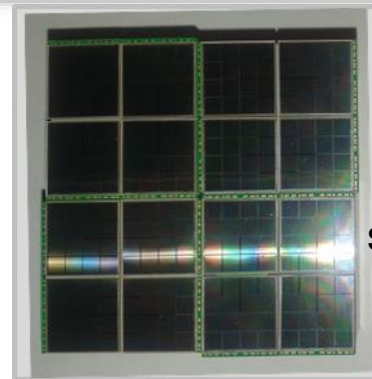
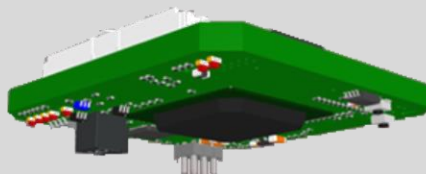
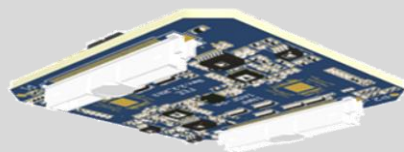
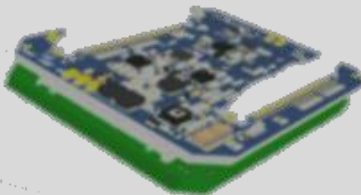
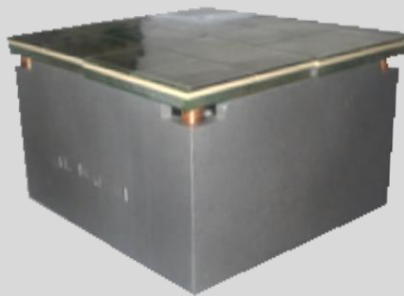

SiPM board
(9 +1 temperature
sensors embedded)

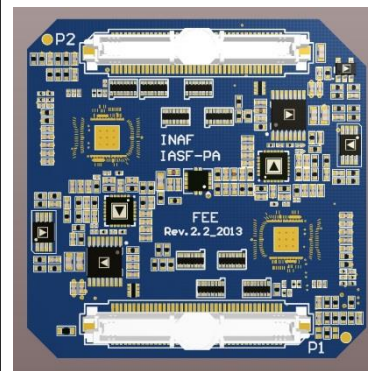

Front-End board
(2 CITIROC
ASIC)

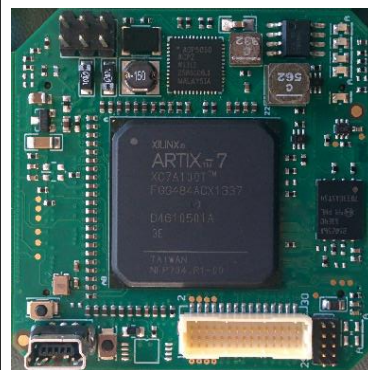

PDM FPGA Board
(XILINX ARTIX 7)

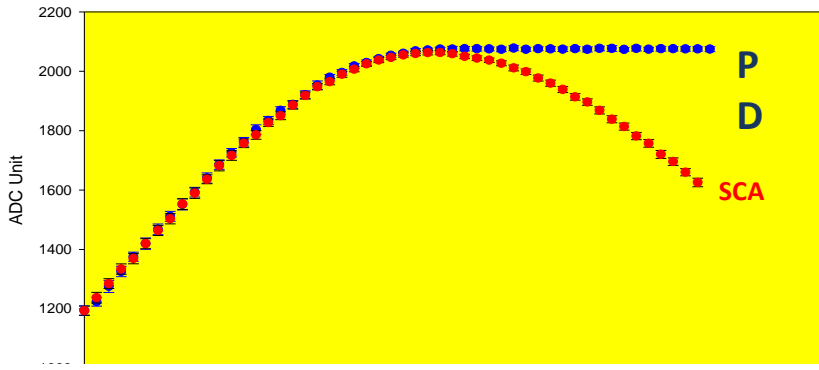

© O. Cataneo INAF Palermo

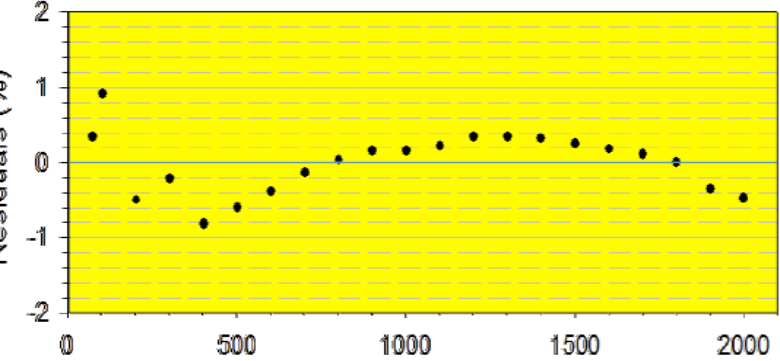
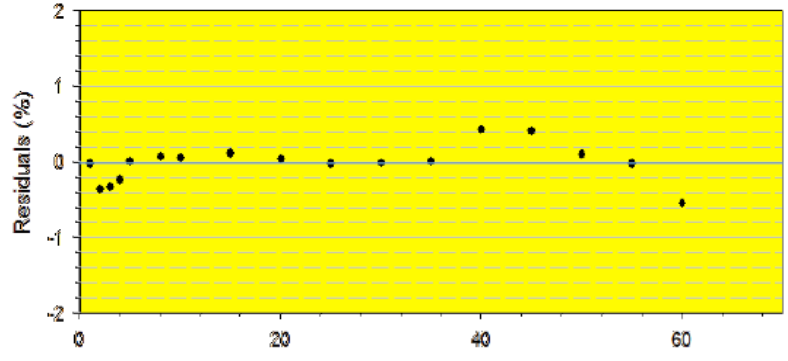
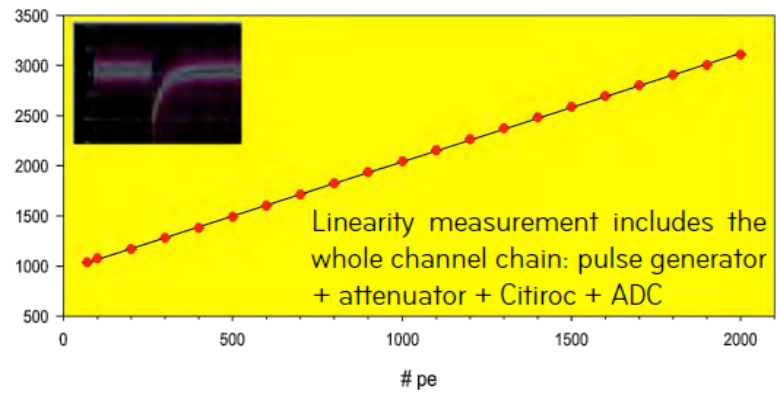
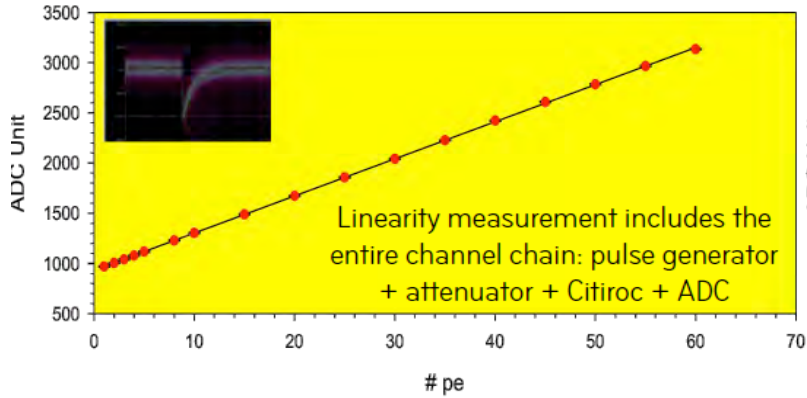

Gain preamplifier = $4 \times 25\text{fF} \approx 150 \text{ nom.}$
 Shaping Time = 50ns
 Steps of 1,2,3,4,5,6,7,8,9,10 pe

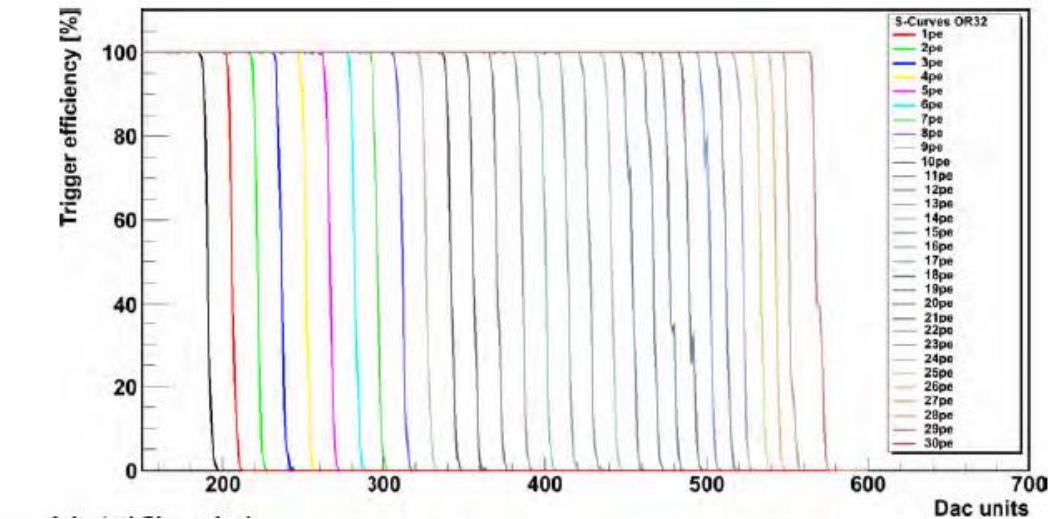
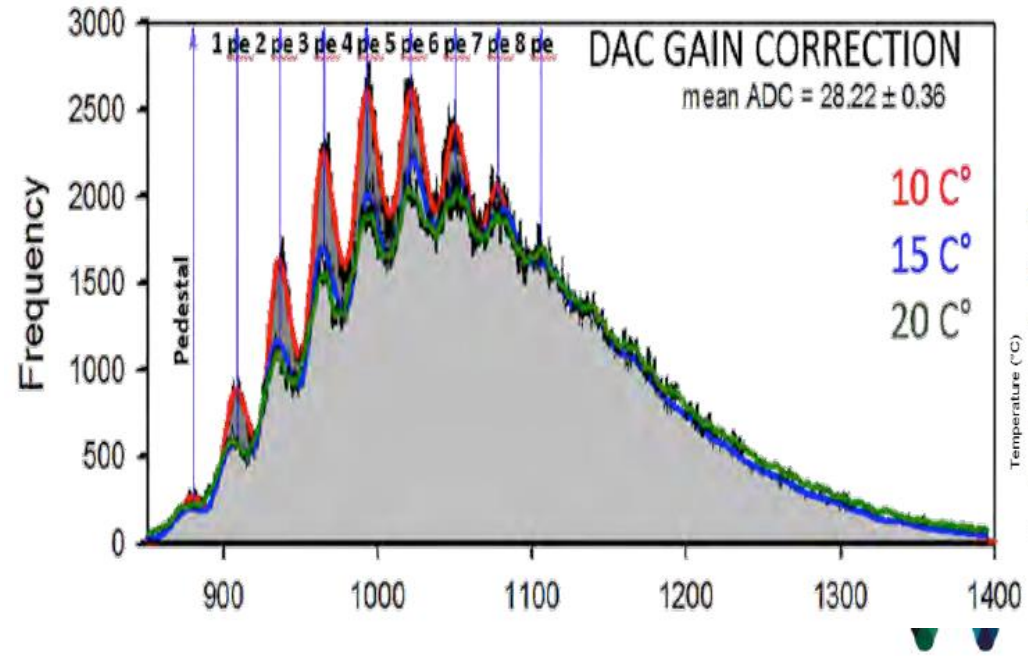

SiPM 4 pixel High Gain = 150
 Shaping Time = 50ns
 delay time = 38 x 2.5 ns
 Temp = 23.7 °C $U_{over} = 1V$
 Resistance = 50 Ohm
 Threshold = 922 DAC ~50% of 1 plateau

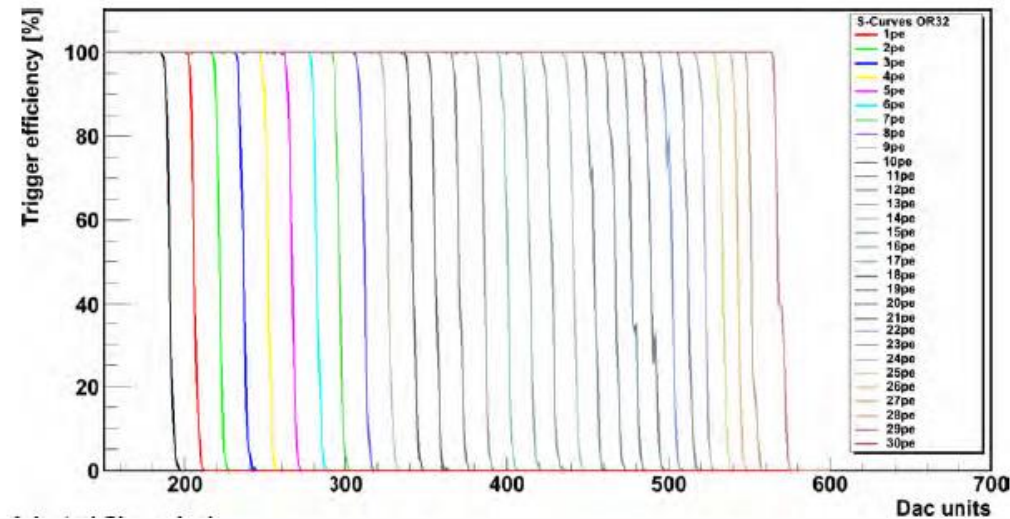

- R&D of 10GHz GBWP preamps for applications where fast timing or high timing resolution is needed (Time Of Flight PET MRI, preclinical, particle physics...)
- 3 architectures in 0.35 μ m SiGe technology integrated and tested

1 pe=160fC

Testboard #3	RF (Common Emitter)	Common Base	Super Common Base
<i>With 100pf/50 Ohm injector (SiPM emulation)</i>		Vb_cb : 400 #DAC	Vb_scb : 1023 #DAC
Noise floor (pedestal)	185-187 #DAC / 1.196V	216-224 #DAC / 1.259V	340-342 #DAC / 1.514V
Signal value @ 10pe	235 #DAC / 1.300V	137 #DAC / 1.085V	115 #DAC / 1.038V
Signal amplitude @ 10pe (signal minus pedestal)	50 #DAC / 110mV	83 #DAC / 174mV	226 #DAC / 476mV
Gain (mV/pe)	10.4mV/pe (5 #DAC/pe)	17.4mV (8.3 #DAC)	47.6mV/pe (22.6 #DAC/pe)
Jitter - threshold 1 pe @10pe	13ps RMS	6ps RMS	8ps RMS
Jitter - threshold 3 pe @10pe	8ps RMS	6ps RMS	8ps RMS
<i>With 100nF DC block (for voltage gain & BW meas.)</i>	18mV injection	18mV injection	7mV injection
Signal Value	267 #DAC / 1.371V	41 #DAC / 0.884V	192 #DAC / 1.2V
Signal amplitude (signal minus pedestal)	81 #DAC / 175mV	179 #DAC / 375mV	150 #DAC / 320mV
Voltage gain (before 50 ohm bridge => factor of 0.5)	4.86 V/V	10.4 V/V	22.5 V/V
Bandwidth, after discriminator (Δt 10% T50% meas.)	Δt : 150ps / 660MHz	Δt : 360ps / 280MHz	Δt : 400ps / 250MHz

⇒ Design of PETIROC1: 16 channels with RF amplifier

⇒ PETIROC2 32ch TRIROC 64 ch

PETIROC1: Triggers on first pe

- Tests on EPTIROC1 (analog version of PETIROC2)
- 1x1mm SiPM Hamamatsu
- Laser for low light injection
 - 405nm, Jitter : 28 ps FWHM
- Petiroc can trigger on first photoelectron
- Petiroc is low noise : single photon identification

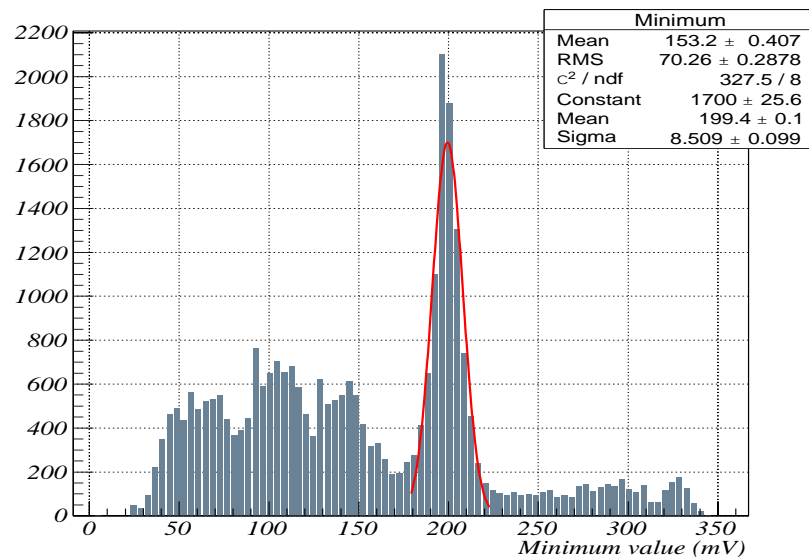

2 ns/div

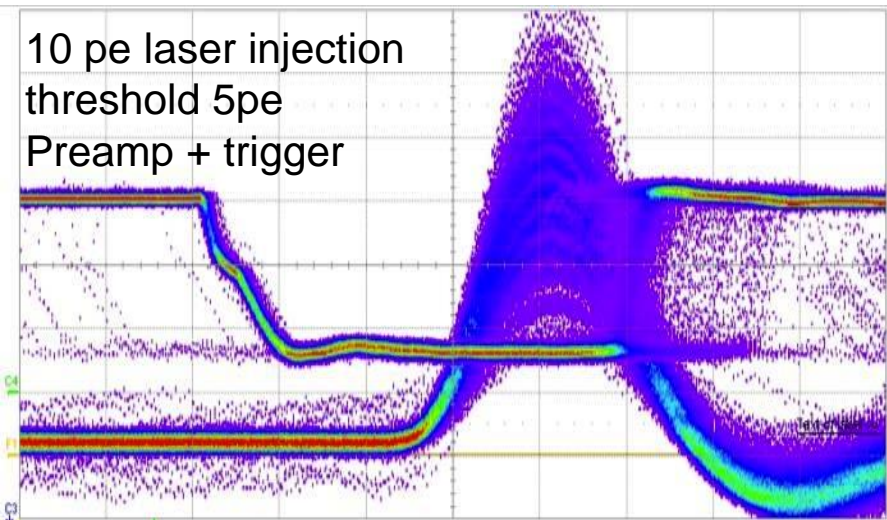

2 ns/div

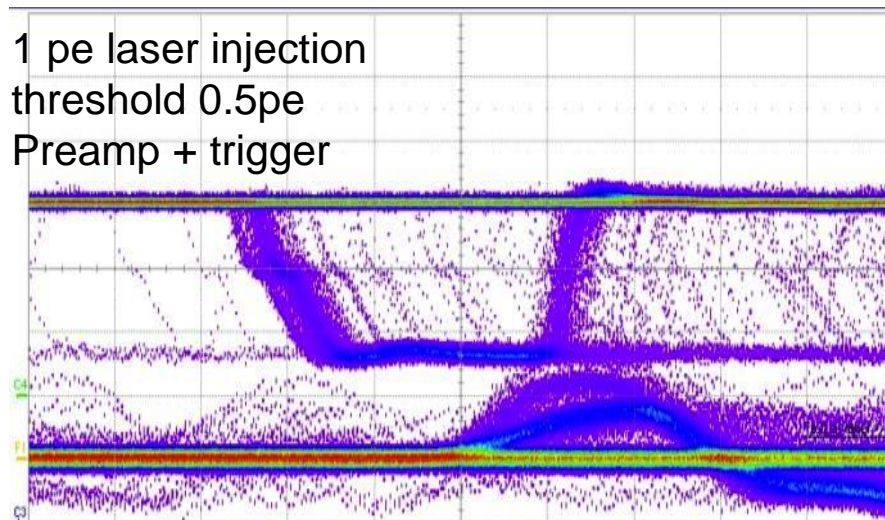

2 ns/div

Petiroc : bandwidth issues

- Pulser vs SiPM comparison
- SiPM is significantly slower than Petiroc
 - Pulser with 100pF injection capacitance, 10pe injected
 - SiPM illuminated with laser pulse, 10pe measured
 - Threshold from 1pe to 9pe
- Petiroc bandwidth meas. : **877MHz** with pulsed
- With SiPM: limitation due to the stray inductance

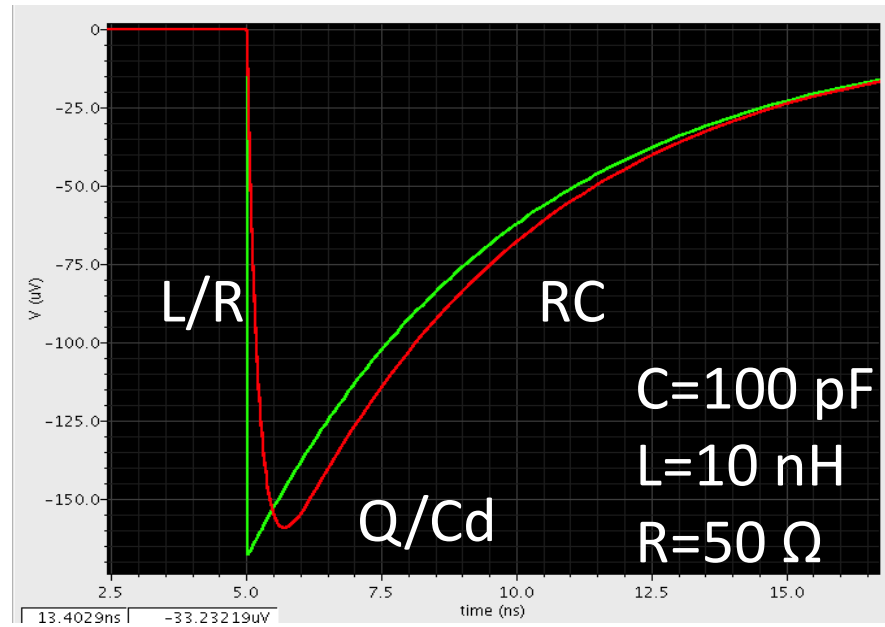
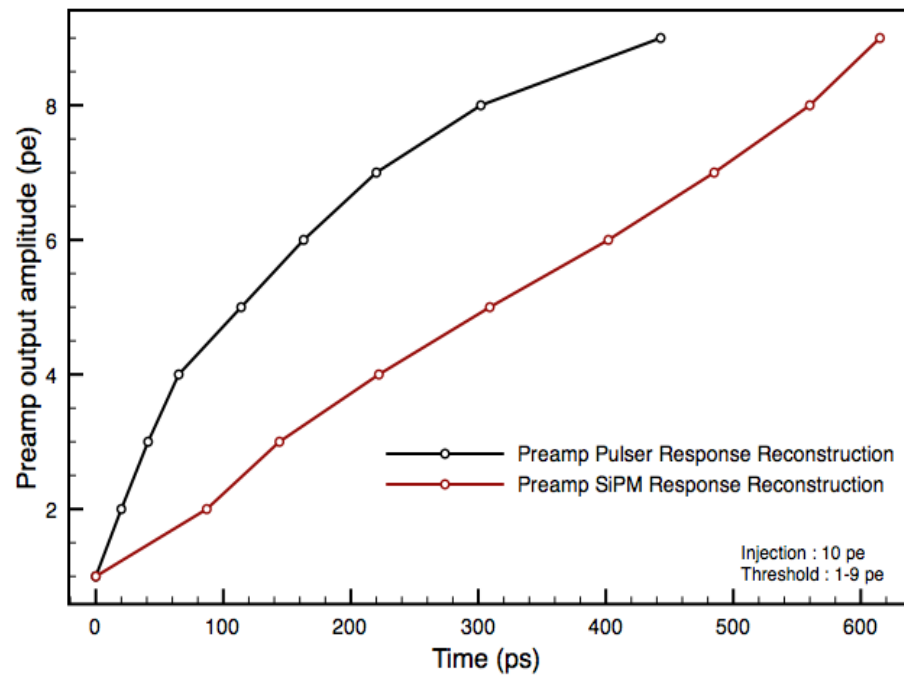
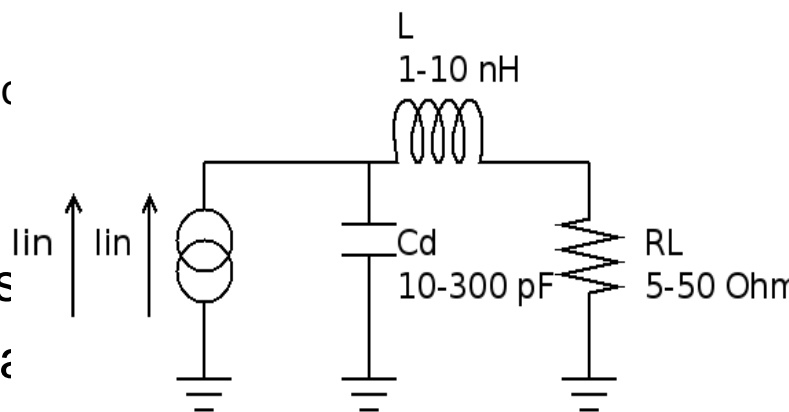

- 32 ch SiPM GHz readout ASIC, dual polarity, 100 fC-400 pC, 6 mW/ch
- 32 trigger outputs and multiplexed data output
- Embedded 10 bit ADC and 50 ps TDC
- Dual threshold : first photons and energy

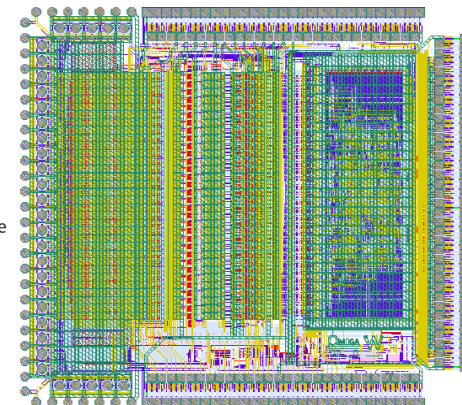
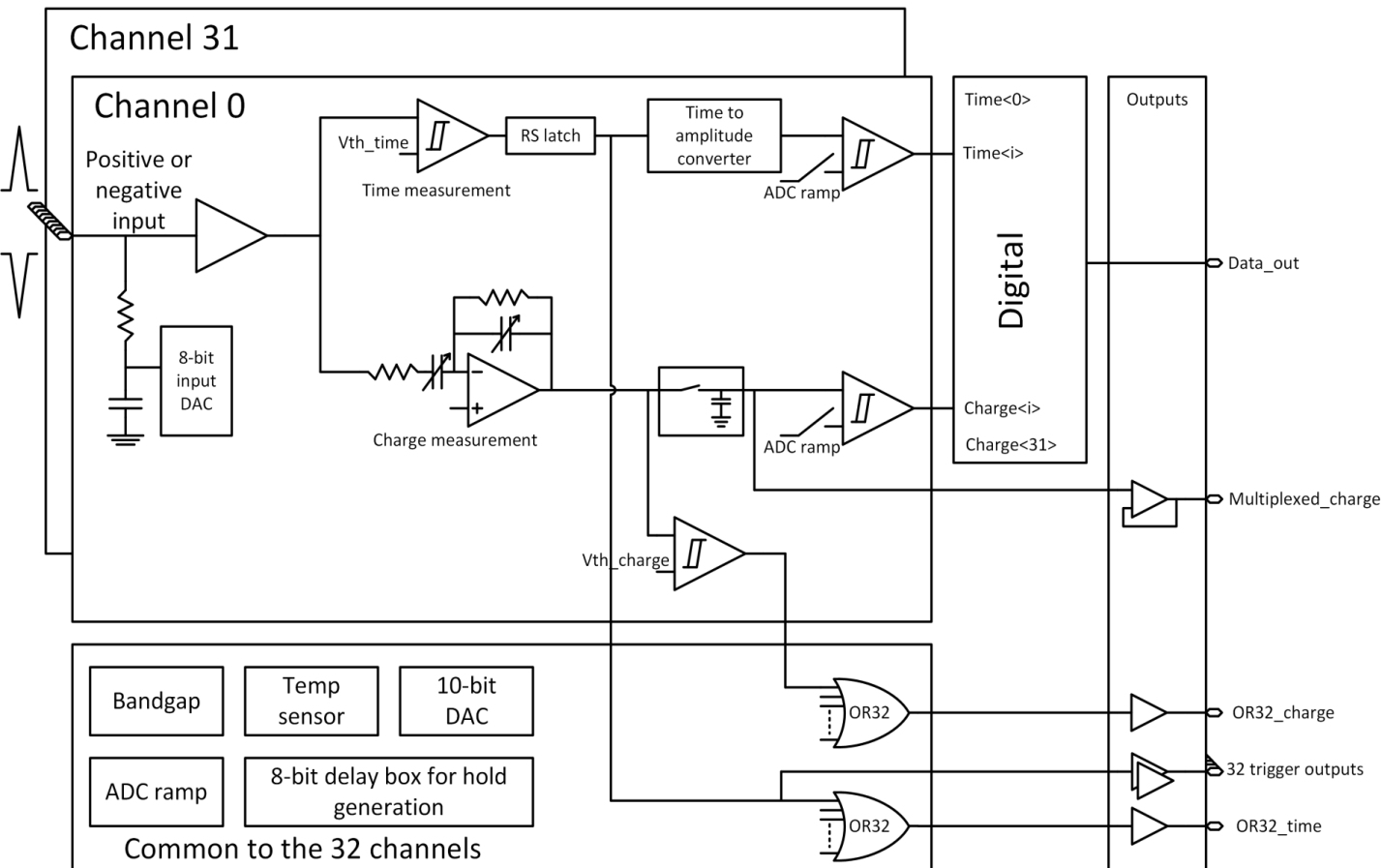

- Linearity and dispersion of the 32 8-bit input DAC

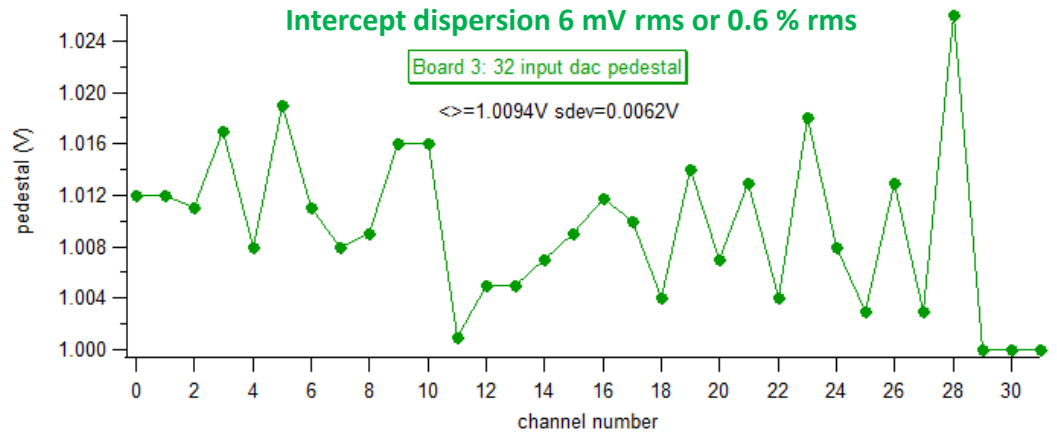
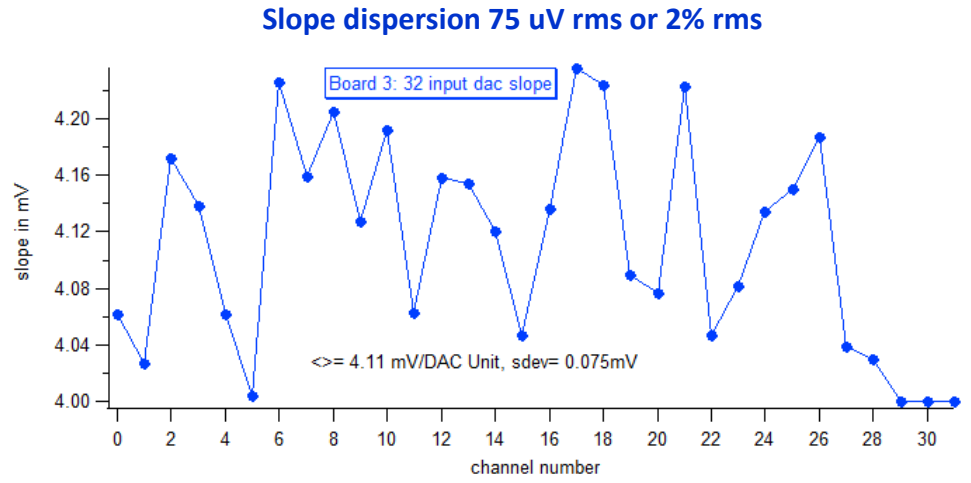
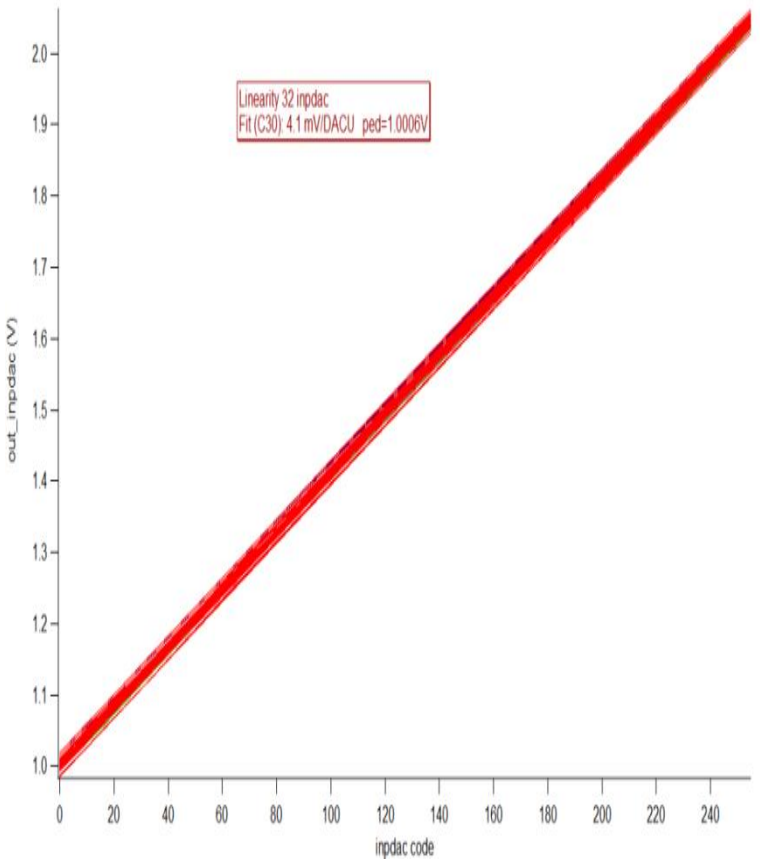

- Trigger efficiency measurements:

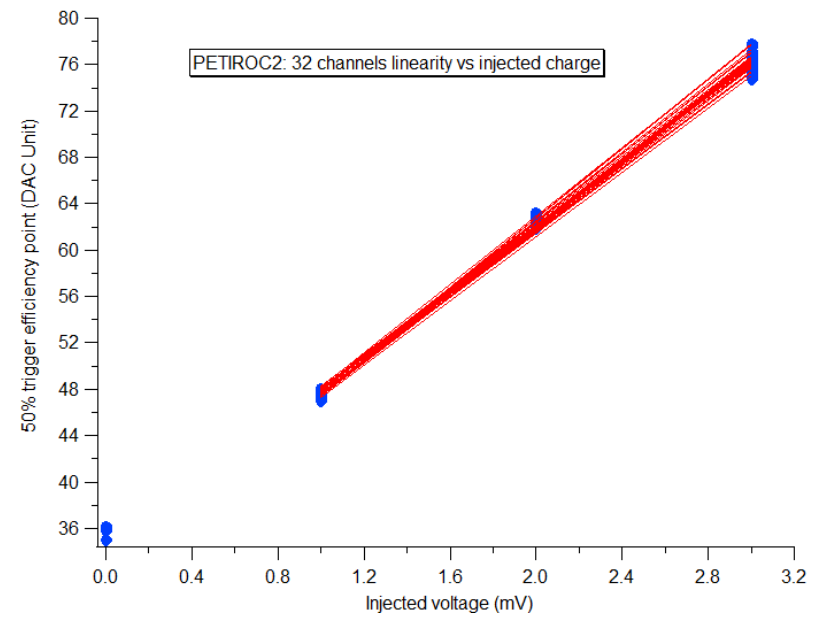
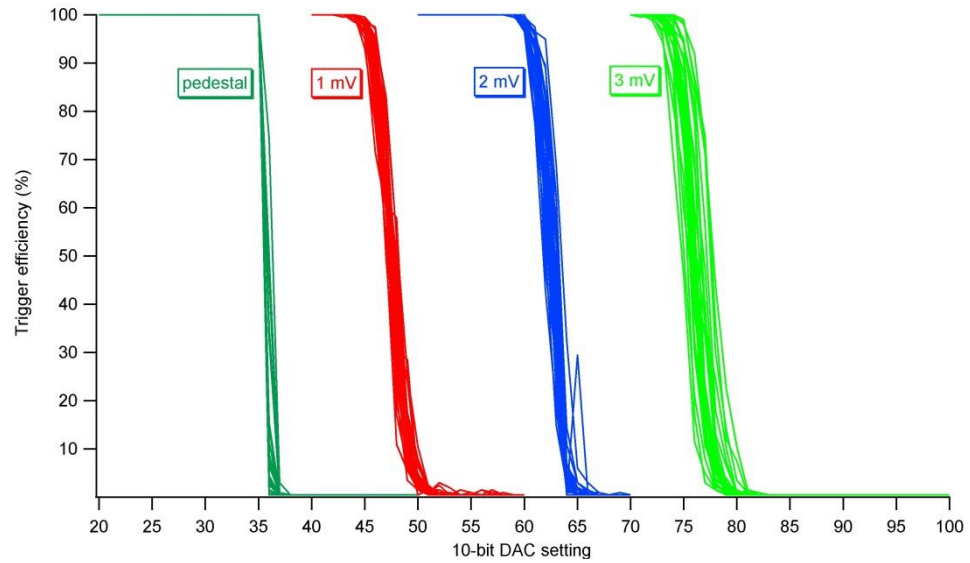
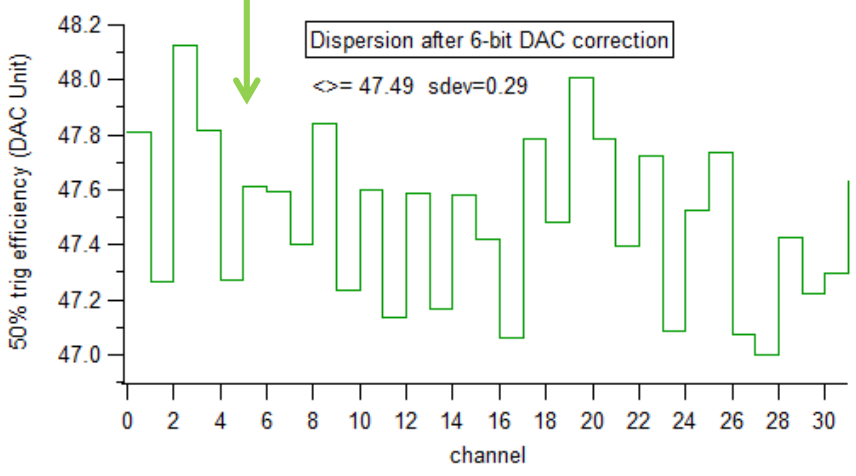
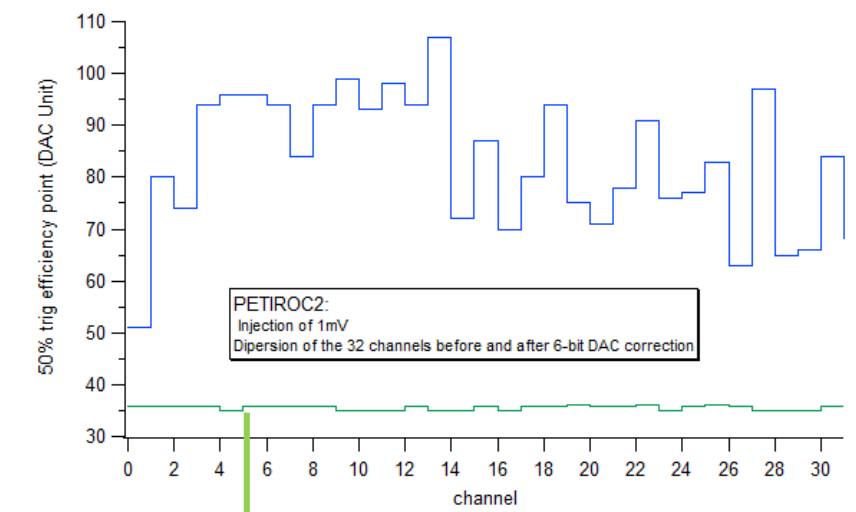

PETIROC2: efficiency uniformity



- Trigger efficiency measurements: Linear
- One 10-bit DAC Unit= 923 μ V

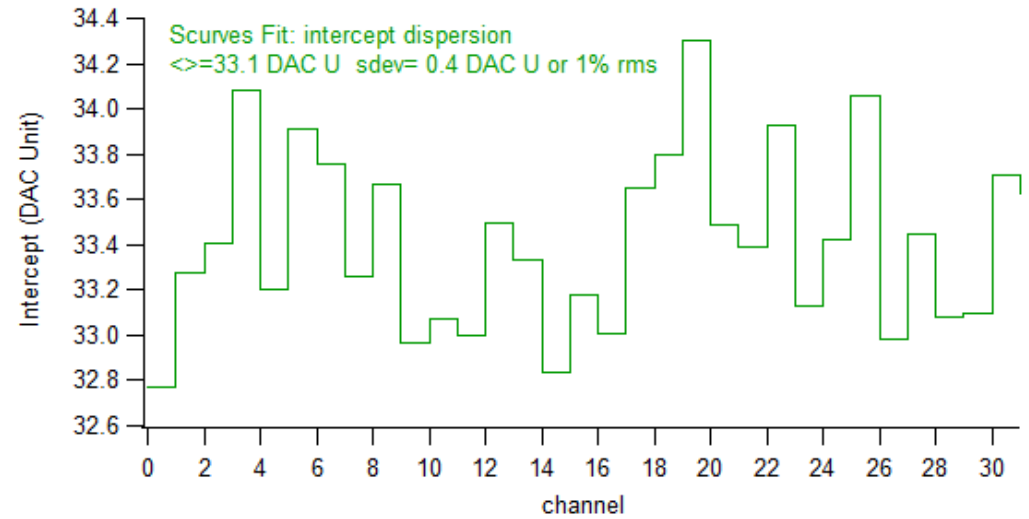
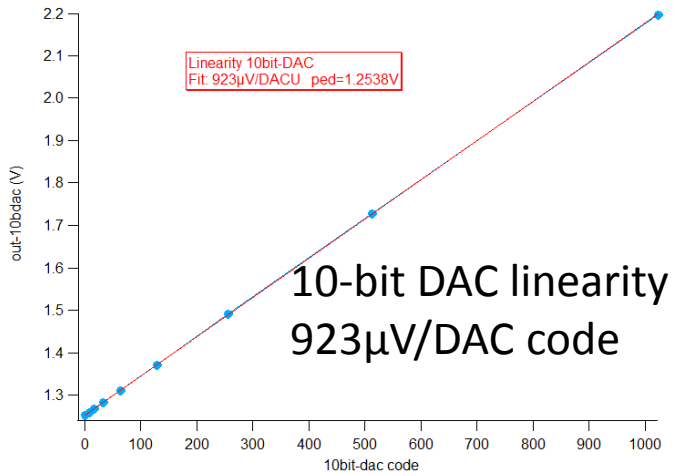
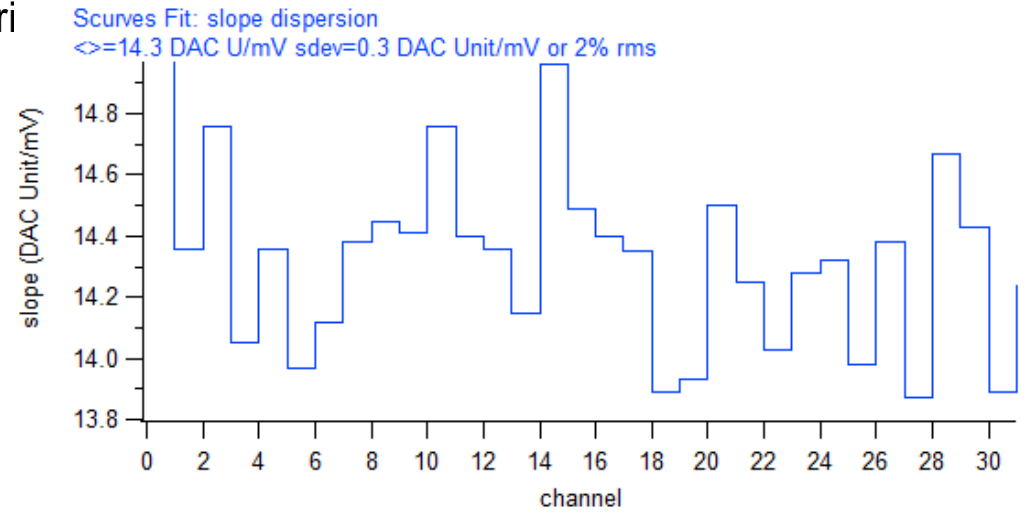
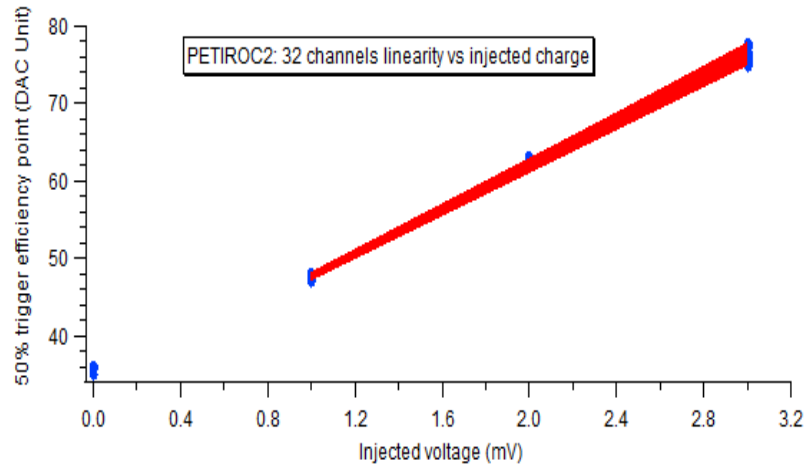

- Jitter vs threshold & injection
- Jitter improves with signal
- Clock couplings (understood)
- Jitter below 20ps

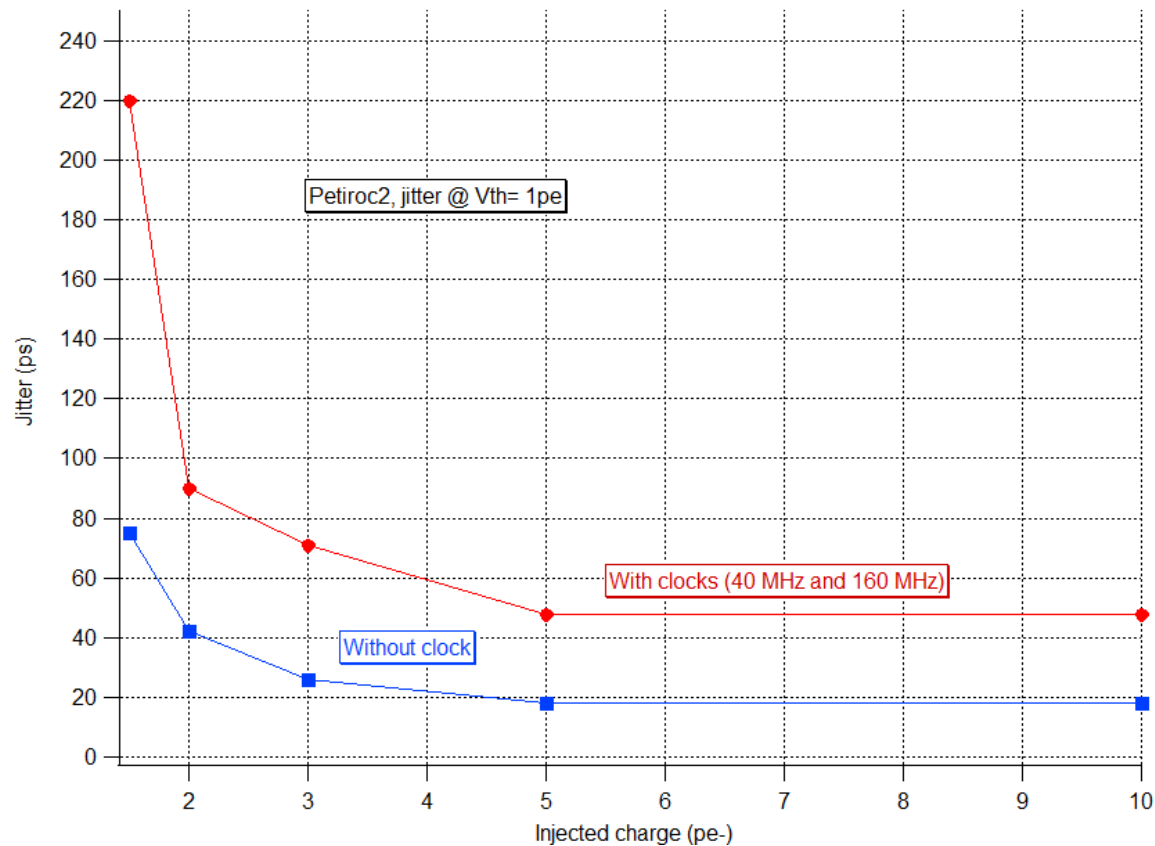

PETIROC2: TAC measurement

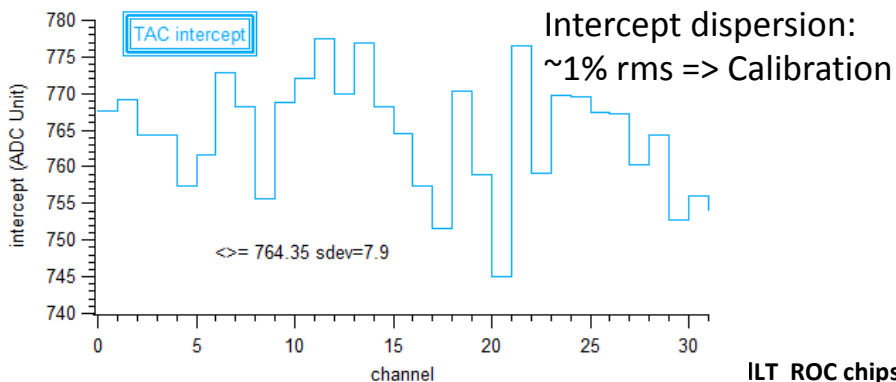
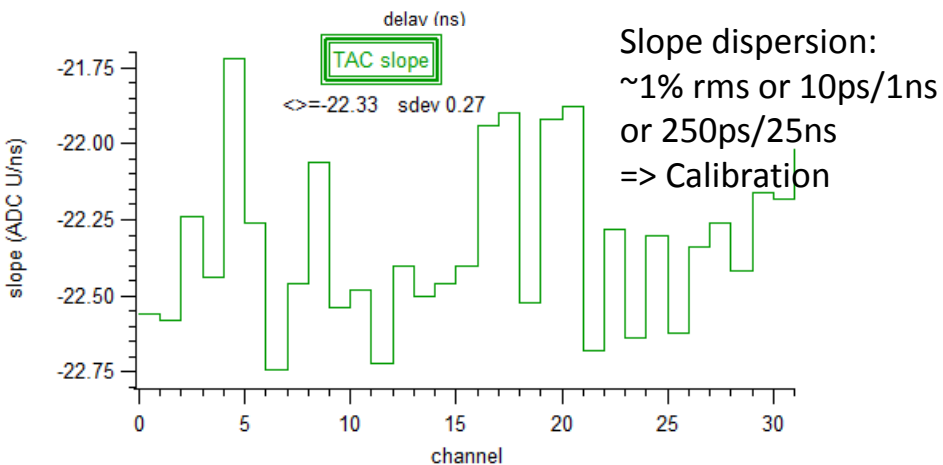
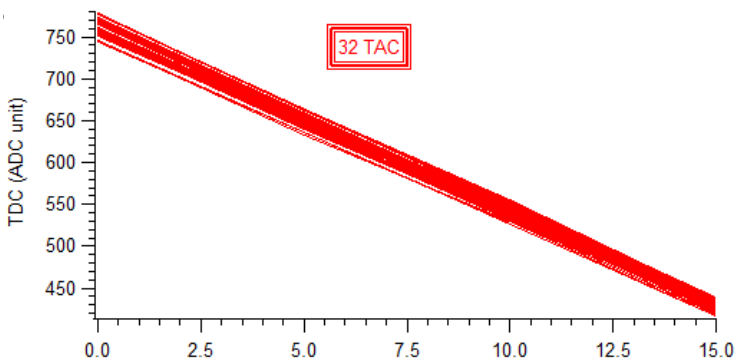

Petiroc 2 TDC output vs. Delay

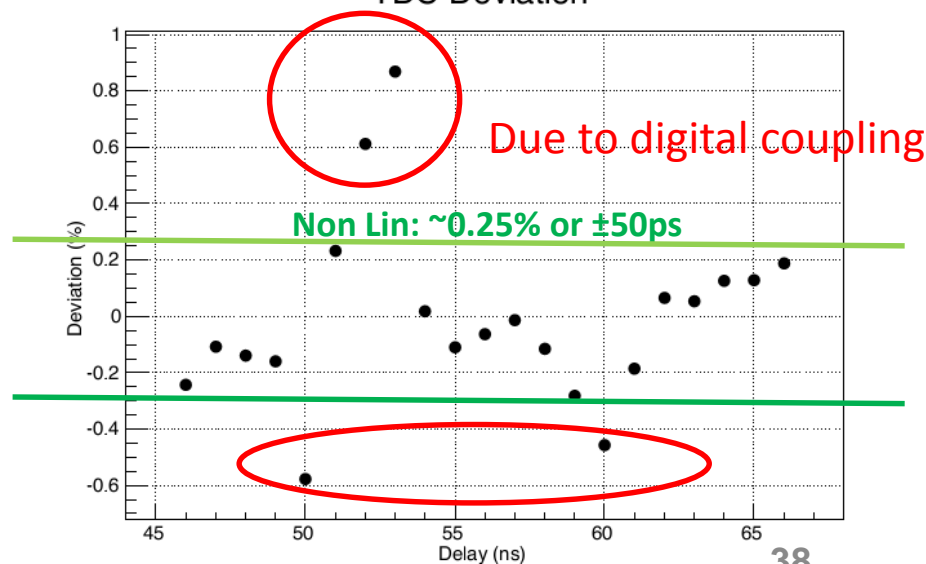
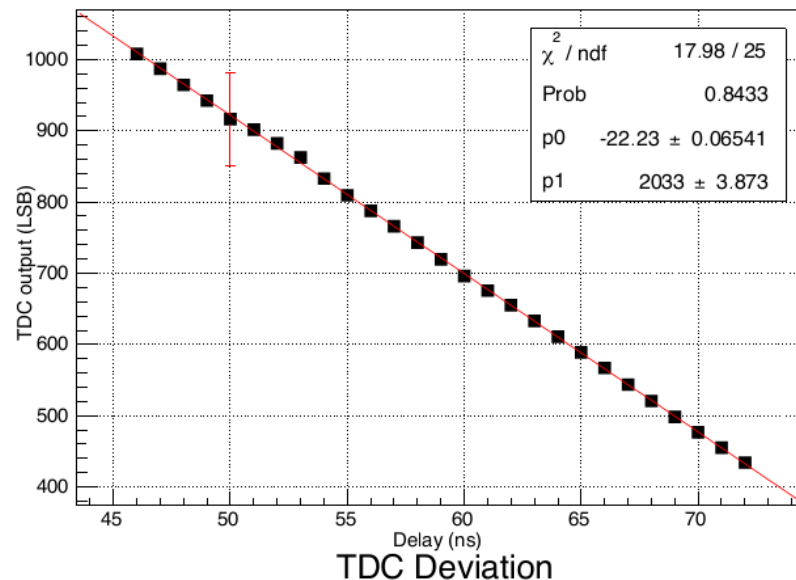

- Cost effective tri-modality (PET – MR – EEG) imaging tools

Project Partners	Role in the project
University of Pisa (UNIFI)	Coordinator & PET system development
Technological Educational Institute of Athens (TEIA)	Dissemination & Monte Carlo simulations
Forschungszentrum Juelich GmbH (FZJ)	Coil design & PET/MR/EEG integration
JARA BRAIN, RWTH (JRB)	Clinical application
Technische Universität München (TUM)	Image quantification & clinical application
University of Zurich (PUK)	Patient recruitment & clinical data analysis
Istituto Nazionale di Fisica Nucleare (INFN)	PET system development & characterization
AdvanSiD (ASD)	SiPMs and chip-scale package development
Weeroc (WRC)	PET modules production & testing
Raytest GmbH (RAY)	Mechanical parts design & market strategy
RS2D (RS2D)	Design, assembly, test 1.5T MRI

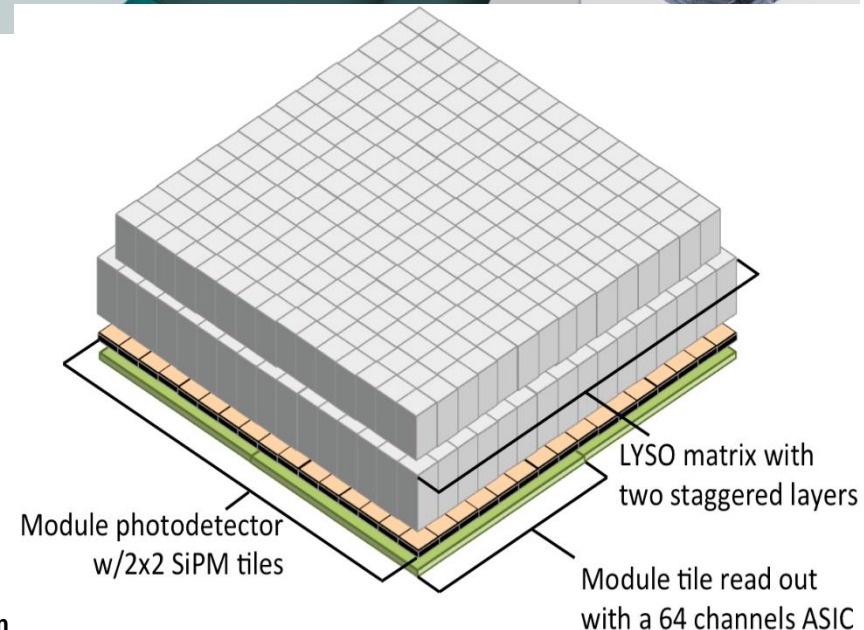
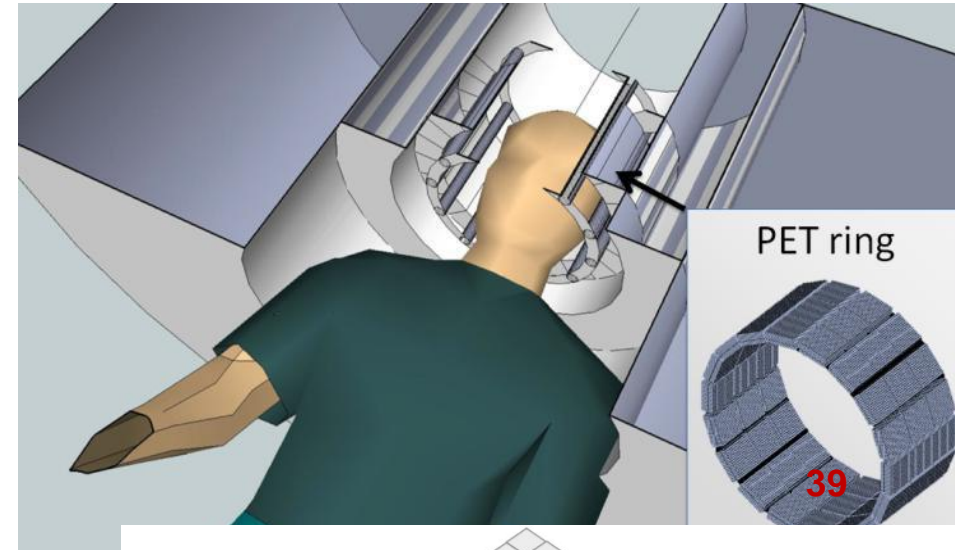

- 64-channel SiPM readout : positive & negative polarity inputs
- 8-bit Input DAC for SiPM HV tuning
- Time Stamp and ADC charge outputs

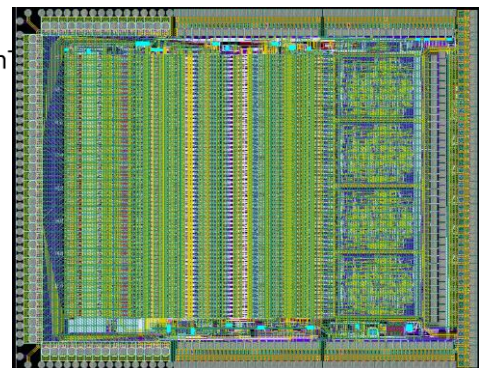
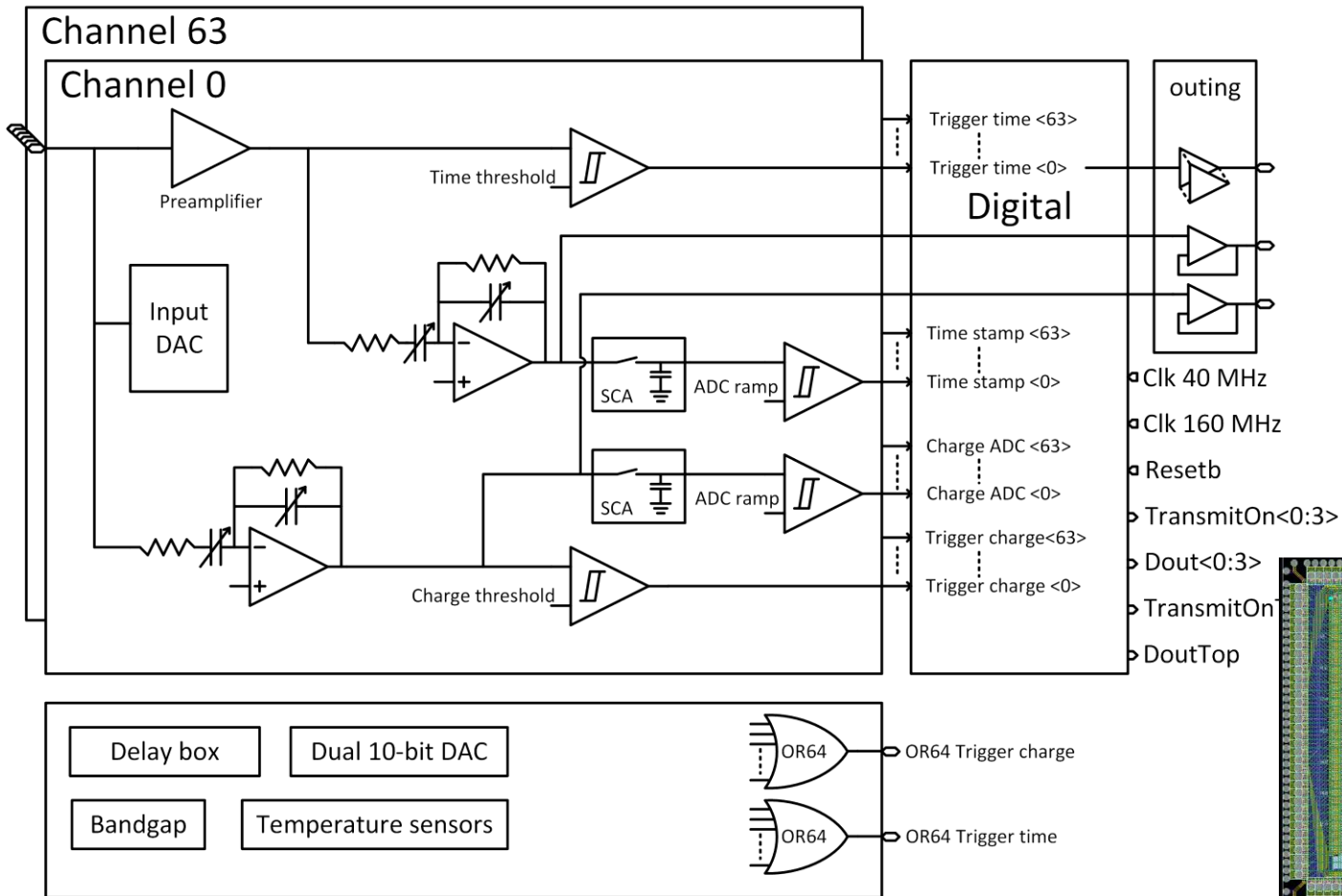

- Several chips transferred to other academic users
- Non-profit « academic price »
- Industry transfer via startup « WEEROC »

chip	year	IN2P3 users	external users
MAROC3	2010	LAL, APC, CSNSM	NEVIS, KEK, CERN, Roma, Seoul, Pisa, Bari, Genève, Mocow, Valencia, Kolkata, Durham, Bruxelles, München, Jülich, Valparaiso, Lisboa, Bristol, Frascati, Budapest, Catania, Glasgow, Coimbra, Grenoble
HARDROC2B	2010	IPNL, LPCCF	
SPIROC2B	2010		DESY (D) , TOHOKU (JP), Bergen (N)
SKIROC2	2010	LAL, LLR	IHEP
SPACIROC1	2010	APC, LAL	
EASIROC	2010	IMNC, LAL, LLR,	Palermo, FNAL, KEK, München, Dijon, CERN, Roma, Aachen, Toulouse, Lyon, Seoul, Bari, Tokyo, Pusan, Kyushu, Osaka
PARISROC2	2010	IPNO, LAPP, LLR, APC	IHEP
CITIROC	2013		INAF , CERN, JLAB, Rio, Berne, Mendoza, Aachen
PETIROC2	2013	IPNL, LPCCF	KEK, Tohoku

- Main activity : Analog and mixed-signal ASIC design
- Research topics :
 - multi-channel ASICs for particle physics and astrophysics detectors
 - BiCMOS SiGe and deep submicron CMOS technologies
 - ultra-low noise, low power and high speed design
 - radiation tolerance, reliability and space applications
 - integration with sensors and System on Chip (SoC)
 - chips for photodetectors, semiconductors or gaseous detectors
- Specific Applications :
 - medical imaging
 - low light "single photon" imaging
 - utilization in space

Chip	Detector	Ch	Polarity	Dyn Range	Specificities
MAROC	PM	64	<0	5 fC - 5 pC	64 trig outputs, internal 8/10/12-bit ADC (for charge measurement)
SPACIROC	PM	64	<0	2 pC- 220 pC	Fast photon counting (50MHz)
PARISROC	PM	16	<0	50 fC - 100 pC	Internal TDC (<1ns), 16 trig outputs
HARDROC	RPC	64	<0	2 fC - 10 pC	3 discriminators, 128 deep digital memory to store 2x64 discriminator encoded data
MICROROC	μMEGAS/GEM	64	<0	0.2 fC - 500 fC	3 discriminators, 128 deep digital memory to store 2x64 discriminator encoded data
SKIROC	Si pin diodes	64	>0	0.3 fC - 10 pC	Internal 12-bit ADC for charge measurement
SPIROC	SiPM	36	>0	10 fC - 300 pC	36 HV SiPM tuning (8 bits), Internal 12-bit ADC for charge and time measurement
EASIROC	SiPM	32	>0	10 fC - 300 pC	32 HV SiPM tuning (8 bits), 32 trigger outputs
CITIROC	SiPM	32	>0	10 fC - 300 pC	32 HV SiPM tuning (8 bits), 32 trigger outputs
PETIROC	SiPM	32	<0	100fC – 300 pC	32 HV SiPM tuning (8 bits), 32 trigger outputs, Internal 10-bit ADC for charge and time measurement (25 ps)
TRIROC	SiPM	64	Both	100 fC- 300 pC	64 HV SiPM tuning (8 bits), 64 trigger outputs, Internal 10-bit ADC for charge and time measurement (25 ps)

- Calorimeter readout: auto-trigger, analog storage, digitization and token-ring readout...
- power pulsing : <1 % duty cycle
- Optimized commonalities within EUDET/AIDA

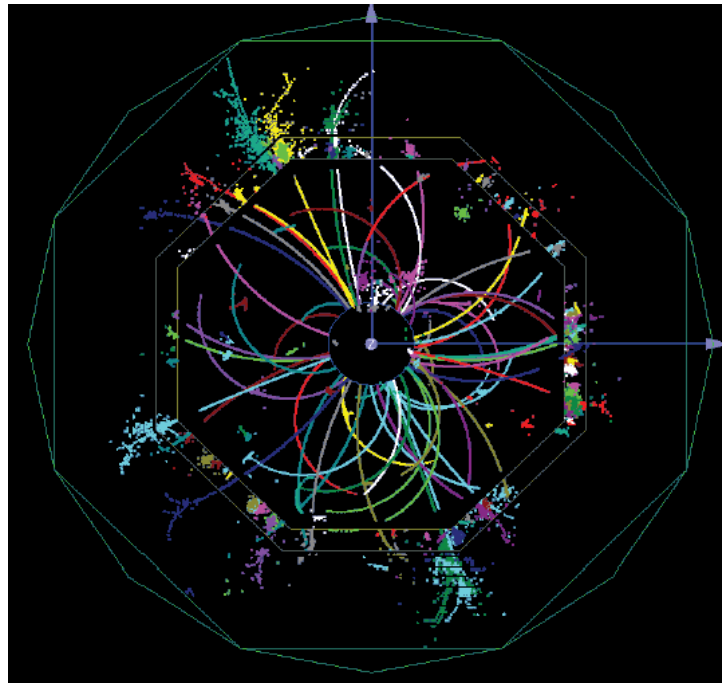
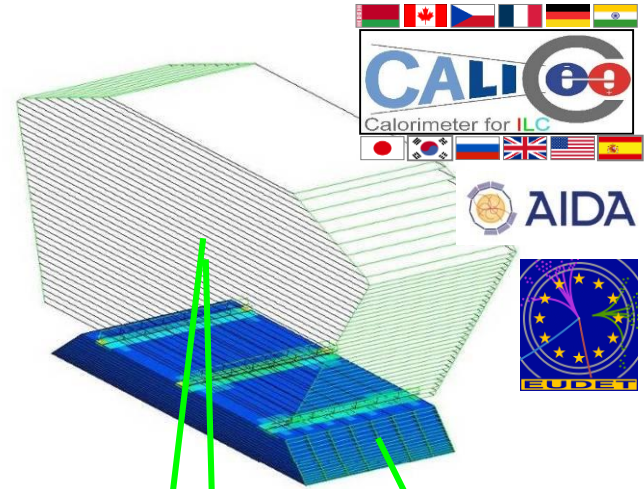

HARDROC2
SDHCAL RPC
64 ch 16 mm²

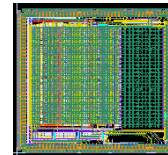

SPIROC2
AHCAL SiPM
36 ch 30 mm²

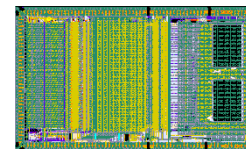

SKIROC2
ECAL Si
64 ch. 70 mm²

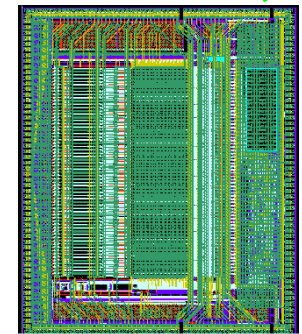

FLC_PHY3
(2003)

- HARDROC2: 64 channels (RPC DHCAL)**

- preamp + shaper+ 3 discris (semi digital readout)
- Auto trigger on 10fC up to 20 pC
- 5 0.5 Kbytes memories to store 127 events
- Full power pulsing => 7.5 μ W/ch
- Fully integrated ILC sequential readout
- 10 000 chips produced to equip 400 000 ch
- SDHCAL technological proto with 40 layers (5760 HR2 chips)
 - Successful TB in 2012 : 40 layers with Power Pulsing mode



cosmic hadronic shower

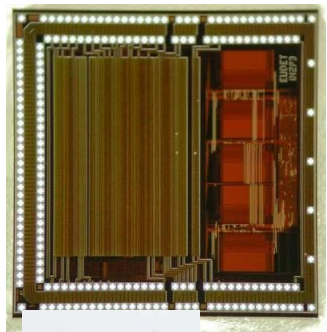
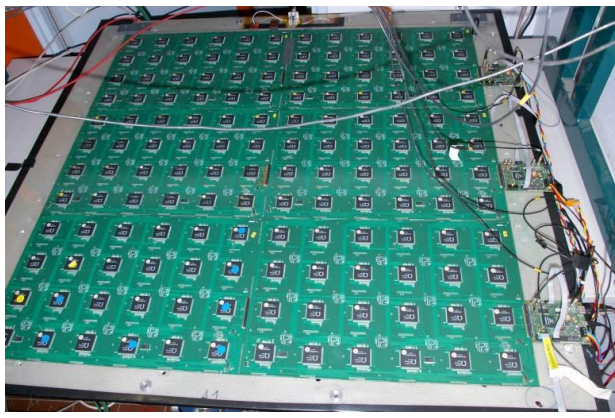

CdLT ROC chips ERDIT Stockholm

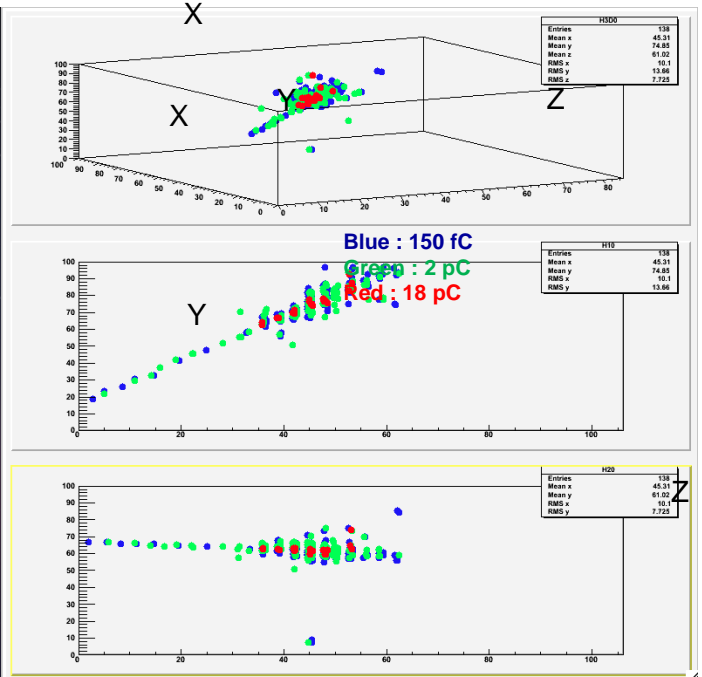

MICROROC: 64 channels for μ Megas (DHCAL ILC)

- ❑ Very similar to HARDROC except for the input preamp (collaboration with LAPP Anney) and shapers (100-150 ns)
- ❑ Noise: **0.2fC Cd=80 pF => Auto trigger on 1fC** up to 500fC
- ❑ Pulsed power: **10 μ W/ch** (0.5 % duty cycle)
- ❑ **HV sparks protection**
- ❑ 1 m² in TB in August and October 2011. Very good performance of the electronics and detector (Threshold set to 1fC).
- ❑ 2012: 4 m² in TB

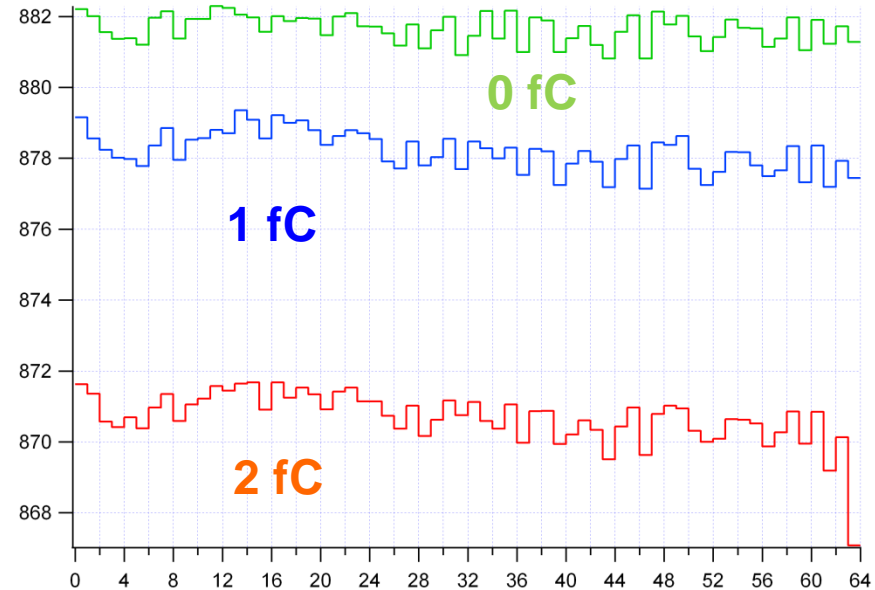

@LAPP Anney



1m² equipped with 144 MICROROC



- 64 ch Si readout chip
 - Autotrigger @ $\frac{1}{2}$ MIP = 2 fC
 - Charge measurement 15 bits
 - Time measurement 1 ns

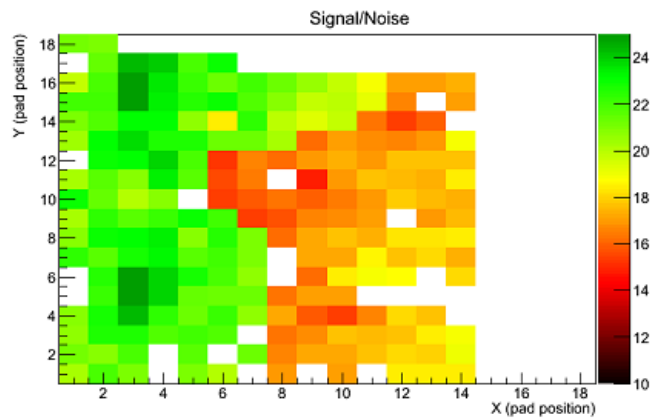
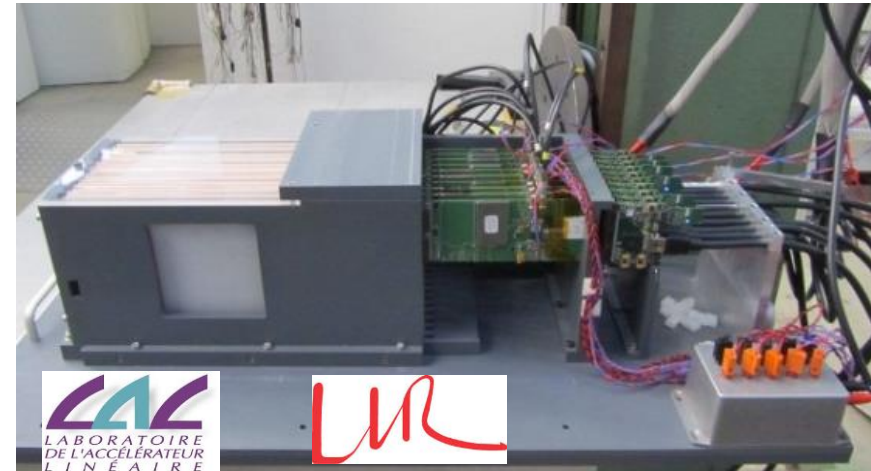

S/N > 10

