

# SUMMER STUDENT LECTURES ON



## ACCELERATORS (2, 3 & 4/5)



Elias Métral (3 × 45 min = 135 min, 92 slides)

1 & 5/5  
⇒ Simone

- 2 {
  - ◆ Introduction and references (4 slides)
  - ◆ Transverse beam dynamics (27)
- 3 {
  - ◆ Longitudinal beam dynamics (12)
  - ◆ Figure of merit for a synchrotron/collider = Brightness/Luminosity (6)
  - ◆ Beam control (8)
- 4 {
  - ◆ Limiting factors for a synchrotron/collider ⇒ Collective effects (34)
    - Space charge (8)
    - Wake field and impedance (12)
    - Beam-beam interaction (8)
    - Electron cloud (6)

+ Discussion Sessions

[Elias.Metral@cern.ch](mailto:Elias.Metral@cern.ch)  
Tel.: 72560 or 164809

## PURPOSE OF THIS COURSE

- ◆ **Try to give you an overview of the basic concepts & vocabulary  $\Rightarrow$  No mathematics, just physics**
- ◆ **...But I would also like you to catch a glimpse of what accelerator physicists are “really” doing, showing you pictures of some recent/current studies**

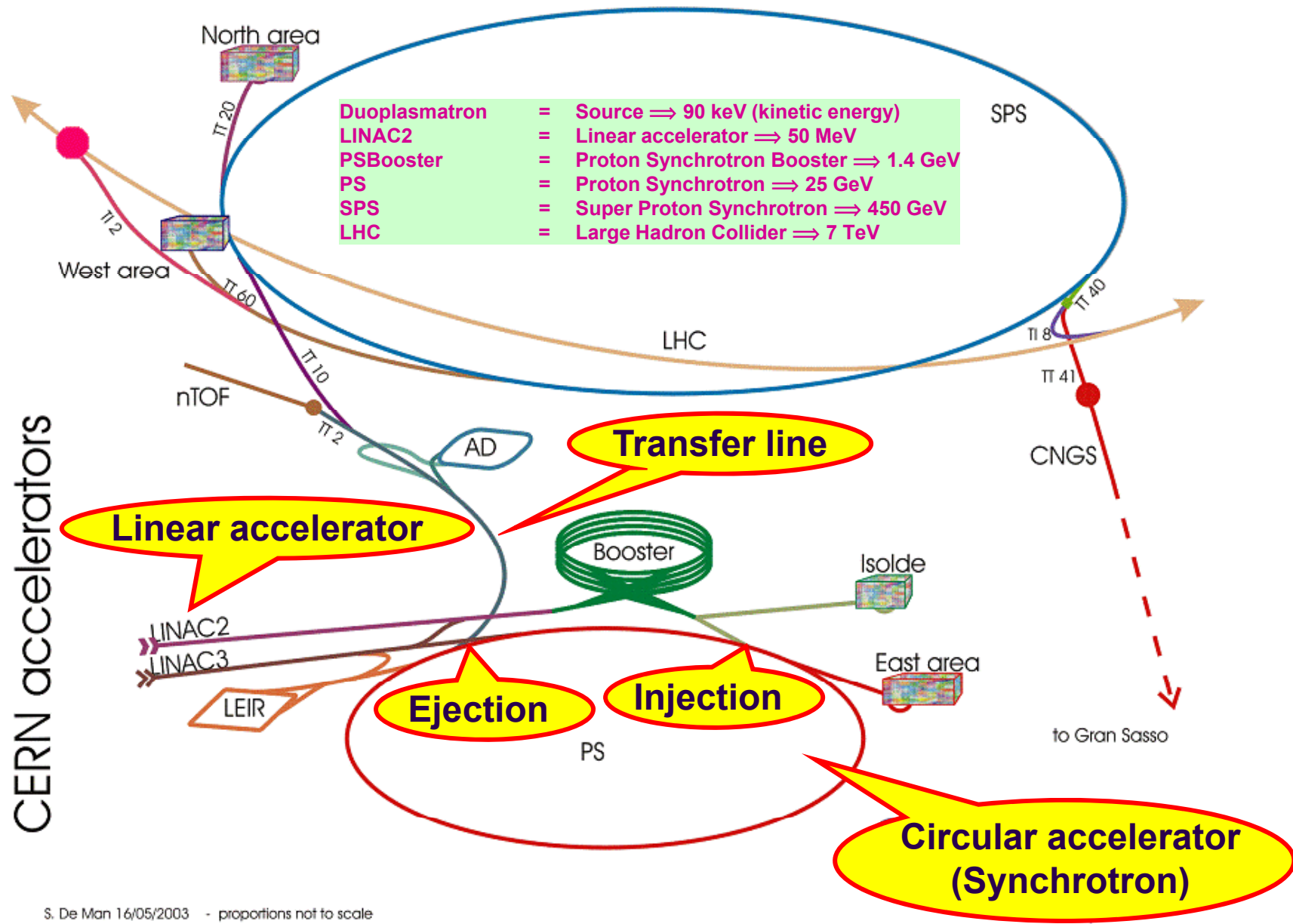

# LHC beam in the injector chain

**PS Booster  
(after the wall)**

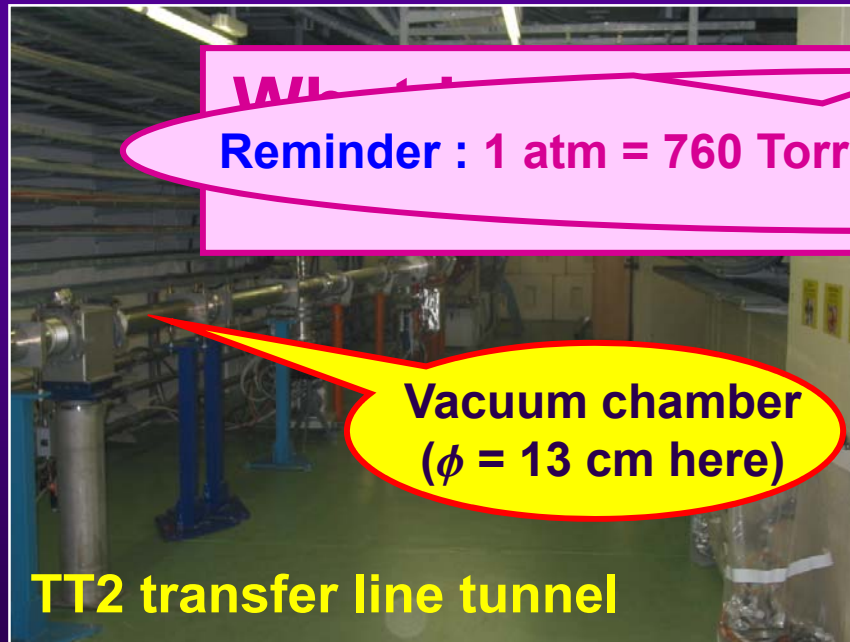
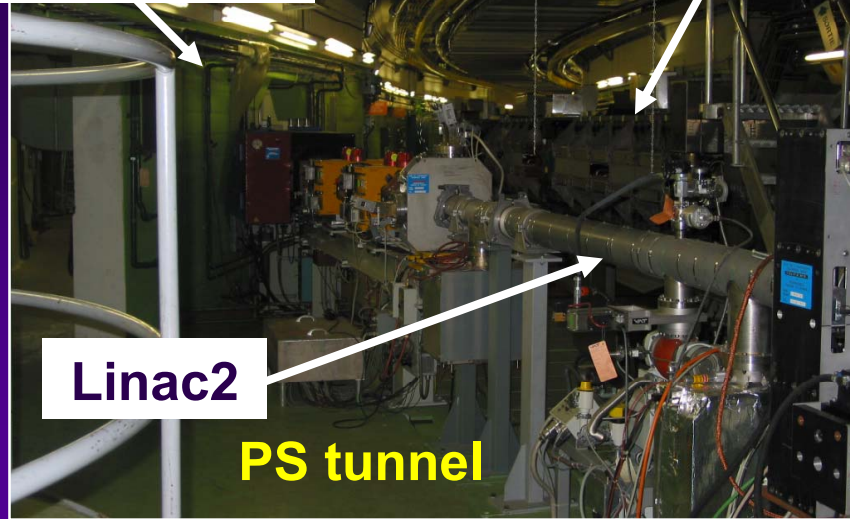

**Reminder : 1 atm = 760 Torr and 1 mbar = 0.75 Torr = 100 Pa**

## REFERENCES

- [0] 2005 Summer Student Lectures of O. Bruning, [<http://agenda.cern.ch/askArchive.php?base=agenda&categ=a054021&id=a054021/transparencies>]
- [1] M. Martini, An Introduction to Transverse Beam Dynamics in Accelerators, **CERN/PS 96-11 (PA), 1996**, [<http://doc.cern.ch/archive/electronic/cern/preprints/ps/ps-96-011.pdf>]
- [2] L. Rinolfi, Longitudinal Beam Dynamics (Application to synchrotron), **CERN/PS 2000-008 (LP), 2000**, [<http://doc.cern.ch/archive/electronic/cern/preprints/ps/ps-2000-008.pdf>]
- [3] Theoretical Aspects of the Behaviour of Beams in Accelerators and Storage Rings: International School of Particle Accelerators of the 'Ettore Majorana' Centre for Scientific Culture, 10–22 November 1976, Erice, Italy, M.H. Blewett (ed.), **CERN report 77-13 (1977)**  
[[http://preprints.cern.ch/cgi-bin/setlink?base=cernrep&categ=Yellow\\_Report&id=77-13](http://preprints.cern.ch/cgi-bin/setlink?base=cernrep&categ=Yellow_Report&id=77-13)]
- [4] CERN Accelerator Schools [<http://cas.web.cern.ch/cas/>]
- [5] K. Schindl, Space Charge, **CERN-PS-99-012-DI, 1999**  
[<http://doc.cern.ch/archive/electronic/cern/preprints/ps/ps-99-012.pdf>]
- [6] A.W. Chao, Physics of Collective Beam Instabilities in High Energy Accelerators, **New York: Wiley, 371 p, 1993** [<http://www.slac.stanford.edu/~achao/wileybook.html>]
- [7] **Web site on LHC Beam-Beam Studies** [<http://wwwslap.cern.ch/collective/zwe/lhcbb/>]
- [8] **Web site on Electron Cloud Effects in the LHC** [<http://ab-abp-rlc.web.cern.ch/ab-abp-rlc-ecloud/>]
- [9] **LHC Design Report** [<http://ab-div.web.cern.ch/ab-div/Publications/LHC-DesignReport.html>]

## TRANSVERSE BEAM DYNAMICS (1/27)

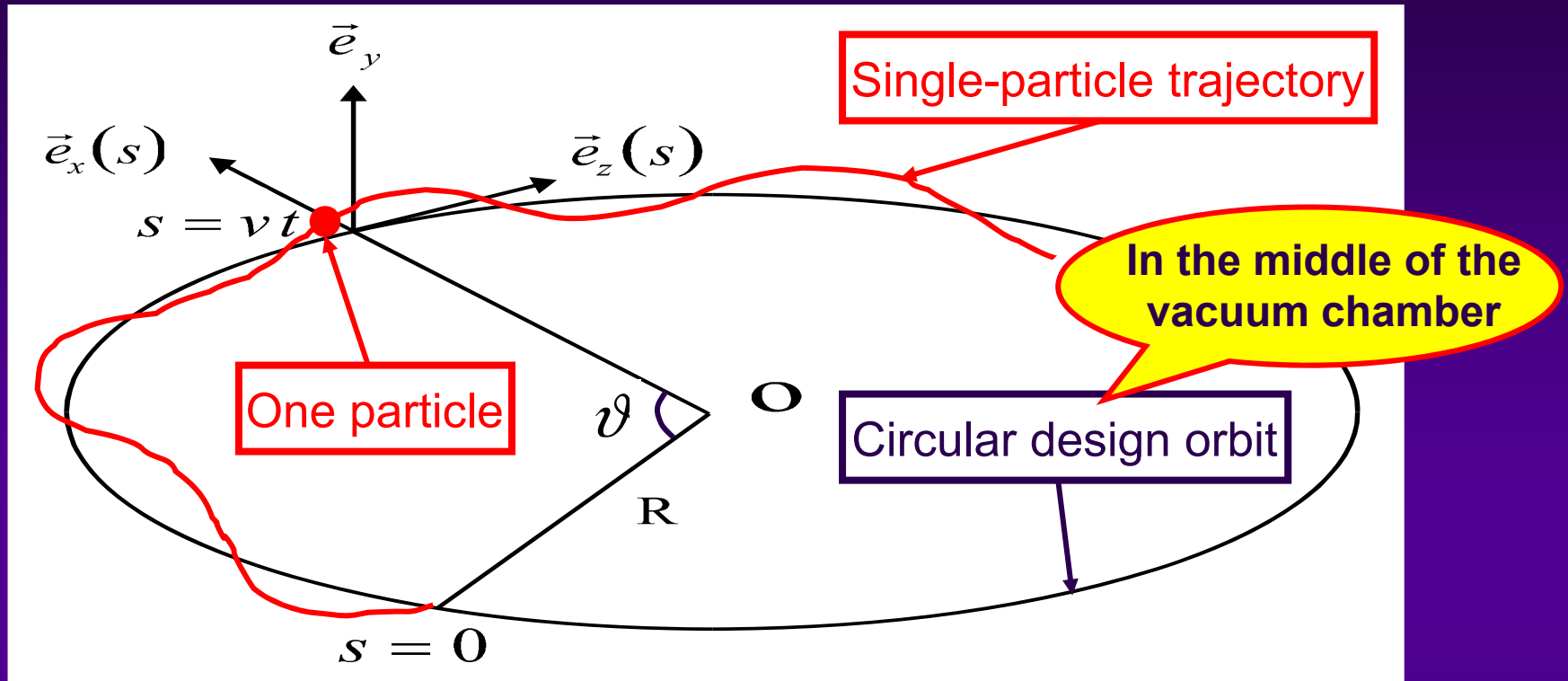

- ◆ The motion of a charged particle (proton) in a beam transport channel or a circular accelerator is governed by the **LORENTZ FORCE**

$$\vec{F} = e \left( \vec{E} + \vec{v} \times \vec{B} \right)$$

- ◆ The motion of particle beams under the influence of the Lorentz force is called **BEAM OPTICS**



## TRANSVERSE BEAM DYNAMICS (2/27)

- ◆ **The Lorentz force is applied as a**
  - **BENDING FORCE (using DIPOLES) to guide the particles along a predefined ideal path, the DESIGN ORBIT, on which – ideally – all particles should move**
  - **FOCUSING FORCE (using QUADRUPOLES) to confine the particles in the vicinity of the ideal path, from which most particles will unavoidably deviate**
- ◆ **LATTICE = Arrangement of magnets along the design orbit**
- ◆ **The ACCELERATOR DESIGN is made considering the beam as a collection of non-interacting single particles**

# TRANSVERSE BEAM DYNAMICS (3/27)

DIPOLE = Bending magnet

Constant force in  $x$   
and 0 force in  $y$

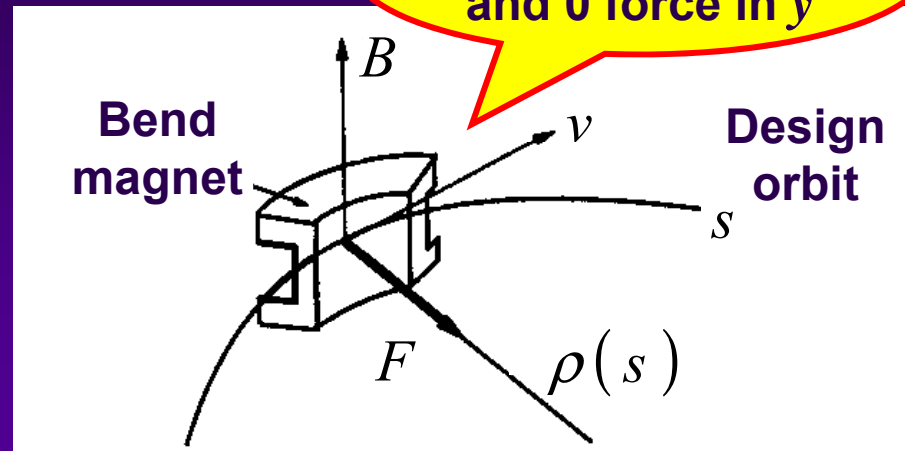
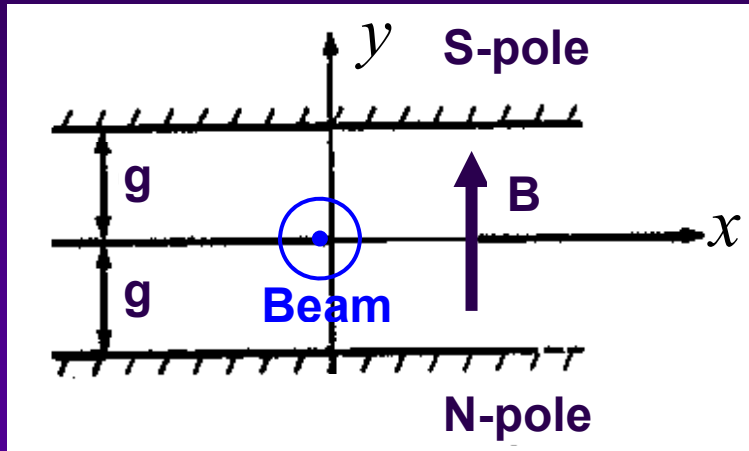

⇒ A particle, with a constant energy, describes a circle in equilibrium between the centripetal magnetic force and the centrifugal force

◆ BEAM RIGIDITY

$$B \rho \text{ [ T m ]} = 3.3356 p_0 \text{ [ GeV / c ]}$$

Magnetic field

Curvature radius of the dipoles

Beam momentum



## TRANSVERSE BEAM DYNAMICS (4/27)

- ◆ LEP vs LHC magnets (in same tunnel)  $\Rightarrow$  A change in technology

	LEP	LHC
$\rho$ [m]	3096.175	2803.95
$p_0$ [GeV/c]	104	7000
$B$ [T]	0.11	8.33

Room-temperature  
coils

Superconducting  
coils

# TRANSVERSE BEAM DYNAMICS (5/27)

## PS magnetic field for the LHC beam

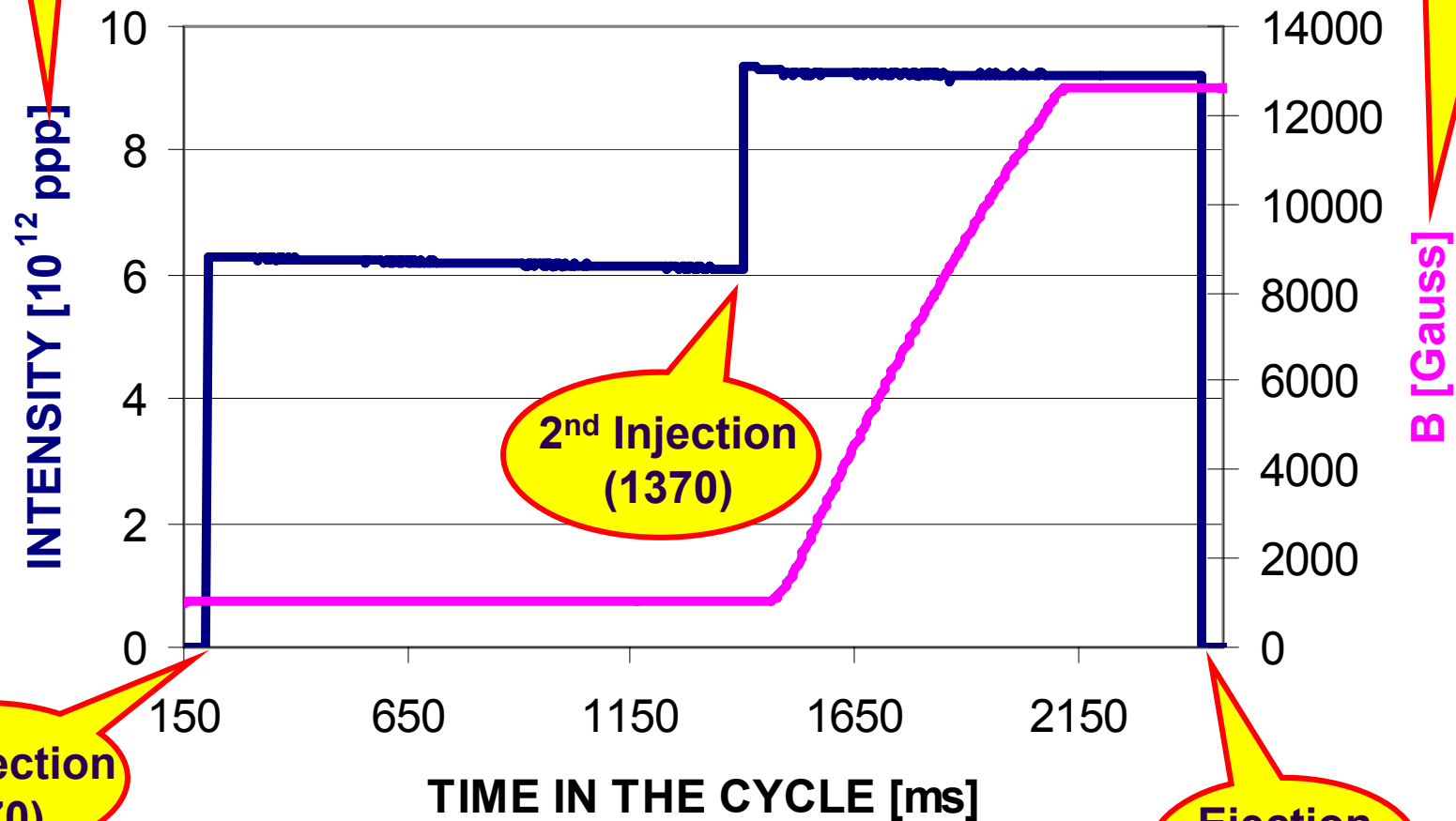

protons per pulse

1 Tesla =  $10^4$  Gauss

B [Gauss]

INTENSITY [ $10^{12}$  ppp]

2<sup>nd</sup> Injection (1370)

1<sup>st</sup> Injection (170)

Ejection (2395)

TIME IN THE CYCLE [ms]

# TRANSVERSE BEAM DYNAMICS (6/27)

## QUADRUPOLE = Focusing magnet

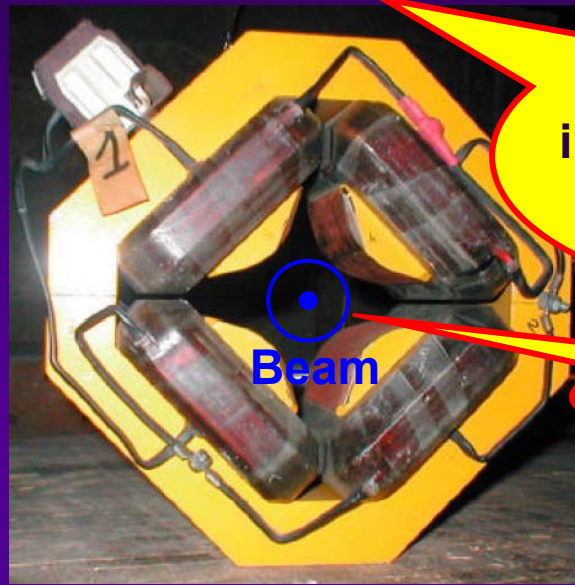
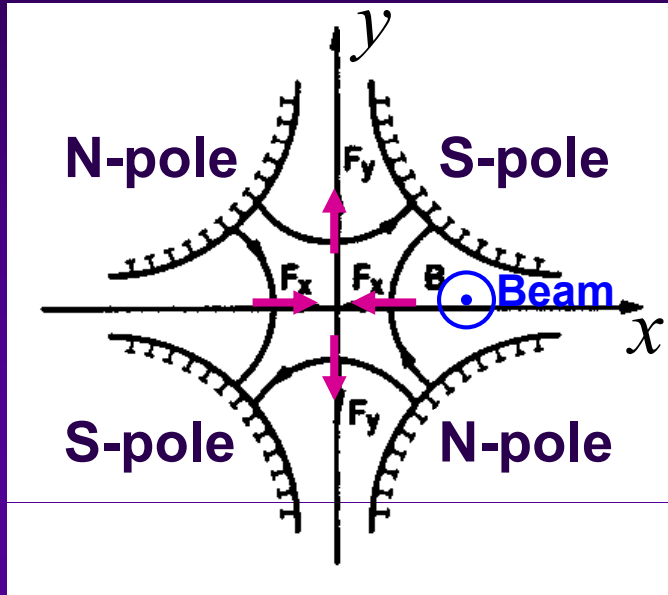

In  $x$  (and Defocusing in  $y$ )  $\Rightarrow$  F-type. Permutating the N- and S- poles gives a D-type

Linear force in  $x$  &  $y$

$\Rightarrow x''(s) + Kx(s) = 0$  : Equation of a harmonic oscillator

- ◆ From this equation, one can already anticipate the elliptical shape of the particle trajectory in the phase space  $(x, x')$  by integration

$$x'^2(s) + Kx^2(s) = \text{Constant}$$

# TRANSVERSE BEAM DYNAMICS (7/27)

## Analogy with light optics

### Principle of focusing for light

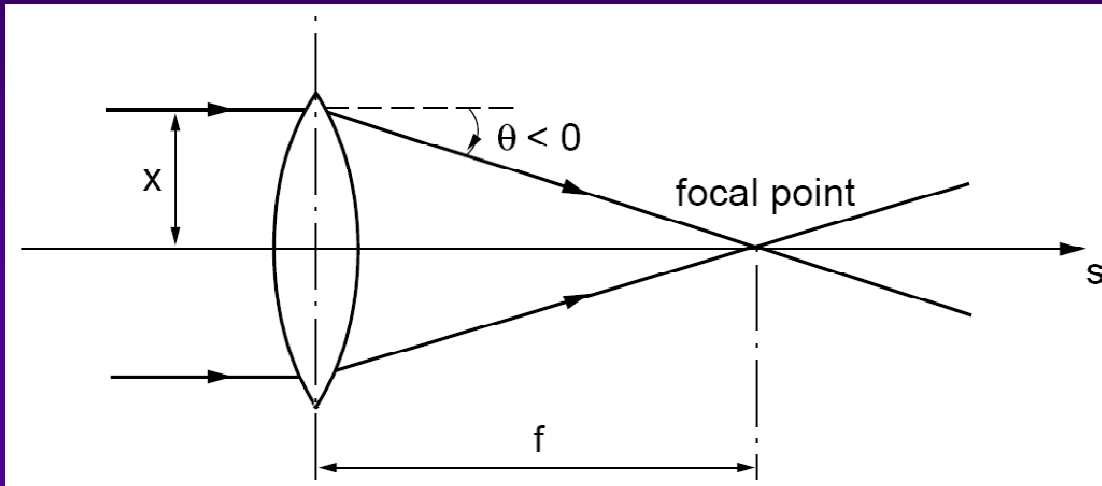

$$\tan \theta = -\frac{x}{f}$$

### Principle of STRONG FOCUSING for light

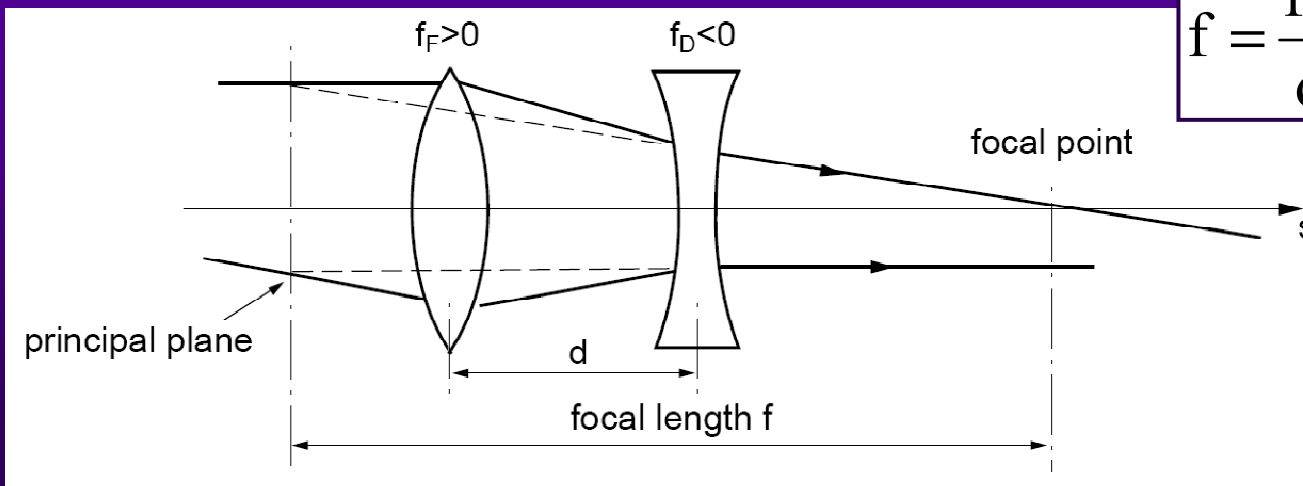

$$f = \frac{f_F^2}{d} > 0 \quad (\text{when } f_D = -f_F)$$

⇒ Focusing in both planes

## TRANSVERSE BEAM DYNAMICS (8/27)

- ◆ **Along the accelerator  $K$  is not constant and depends on  $s$  (and is periodic)  $\Rightarrow$  The equation of motion is then called HILL'S EQUATION**
- ◆ **The solution of the Hill's equation is a pseudo-harmonic oscillation with varying amplitude and frequency called BETATRON OSCILLATION**

Betatron function

$$x(s) = a \sqrt{\beta(s)} \cos[\mu(s) + \varphi]$$

- ◆ **An invariant, i.e. a constant of motion, (called COURANT-SNYDER INVARIANT) can be found from the solution of the Hill's equation**  
  
 $\Rightarrow$  **Equation of an ellipse (motion for one particle) in the phase space plane  $(x, x')$ , with area  $\pi a^2$**

# TRANSVERSE BEAM DYNAMICS (9/27)

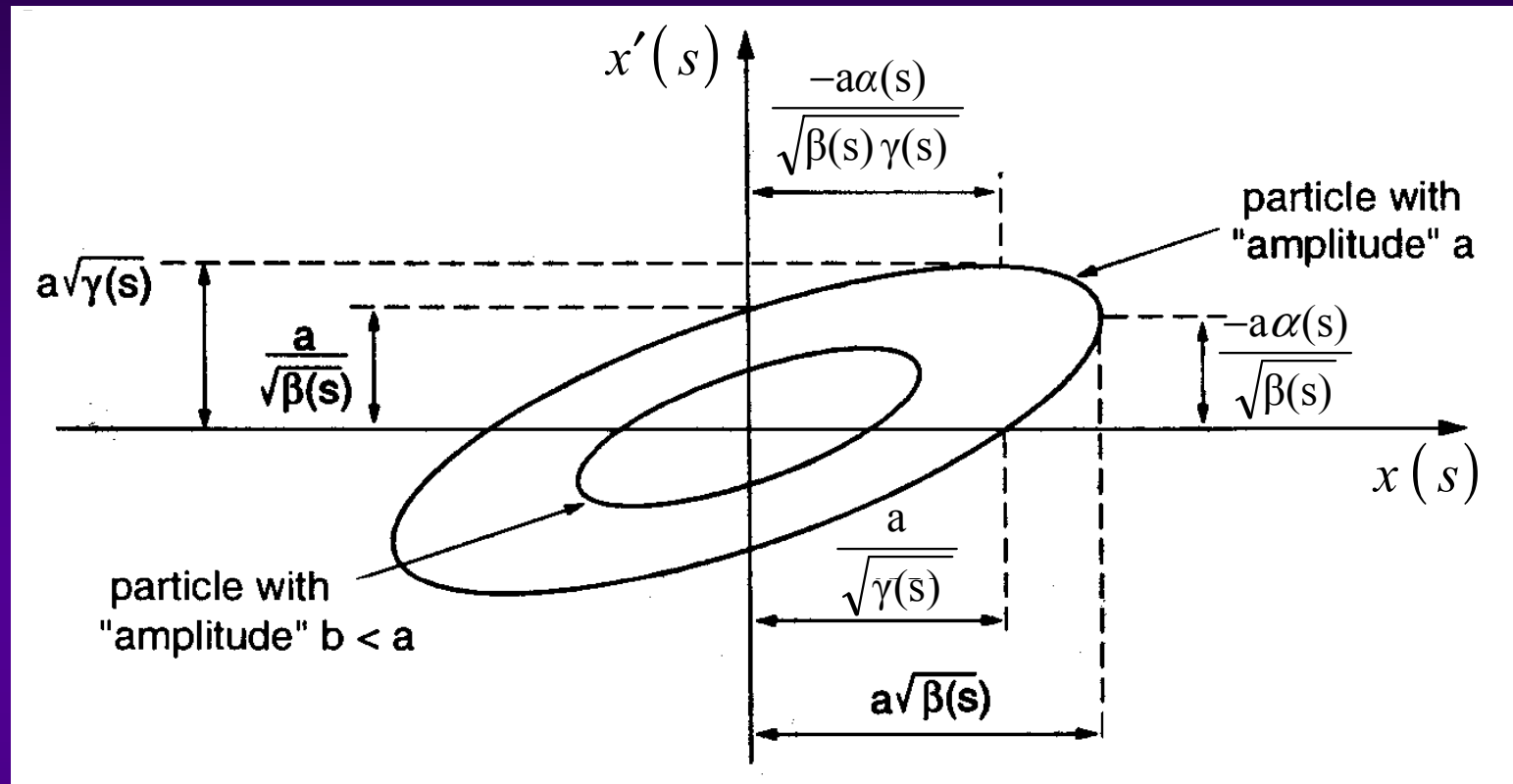

$\beta(s)$   $\alpha(s) = -\frac{\beta'(s)}{2}$   $\gamma(s) = \frac{1 + \alpha^2(s)}{\beta(s)}$  are called TWISS PARAMETERS

- ◆ The shape and orientation of the phase plane ellipse evolve along the machine, but not its area



# TRANSVERSE BEAM DYNAMICS (10/27)

## Stroboscopic representation or POINCARÉ MAPPING

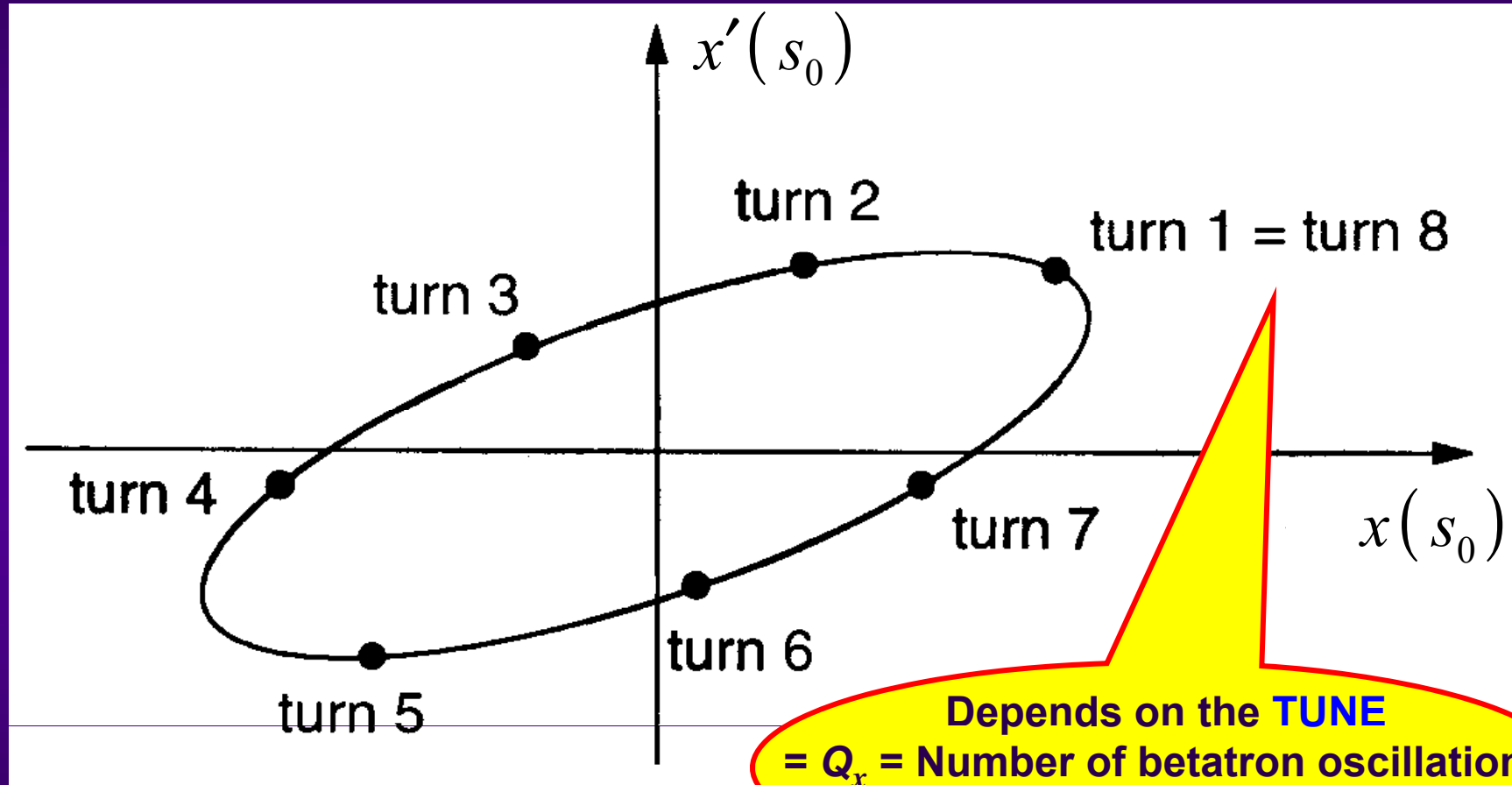

Depends on the **TUNE**  
=  $Q_x$  = Number of betatron oscillations  
per machine revolution

$$Q_x = \frac{\mu(2\pi R)}{2\pi}$$

## TRANSVERSE BEAM DYNAMICS (11/27)

- ◆ **MATRIX FORMALISM:** The previous (linear) equipments of the accelerator (extending from  $s_0$  to  $s$ ) can be described by a matrix,  $M (s / s_0)$ , called **TRANSFER MATRIX**, which relates  $(x, x')$  at  $s_0$  and  $(x, x')$  at  $s$

$$\begin{bmatrix} x(s) \\ x'(s) \end{bmatrix} = M(s / s_0) \begin{bmatrix} x(s_0) \\ x'(s_0) \end{bmatrix}$$

- ◆ The transfer matrix over one revolution period is then the product of the individual matrices composing the machine
- ◆ The transfer matrix over one period is called the **TWISS MATRIX**
- ◆ Once the Twiss matrix has been derived the Twiss parameters can be obtained at any point along the machine

## TRANSVERSE BEAM DYNAMICS (12/27)

- ◆ In practice, particle beams have a finite dispersion of momenta about the ideal momentum  $p_0$ . A particle with momentum  $p \neq p_0$  will perform betatron oscillations around A DIFFERENT CLOSED ORBIT from that of the reference particle

⇒ Displacement of

$$x_{\Delta}(s) = D_x(s) \frac{p - p_0}{p_0} = D_x(s) \frac{\Delta p}{p_0}$$

$D_x(s)$  is called the DISPERSION FUNCTION

# TRANSVERSE BEAM DYNAMICS (13/27)

## ◆ LHC optics for the Interaction Point (IP) 5 (CMS) in collision

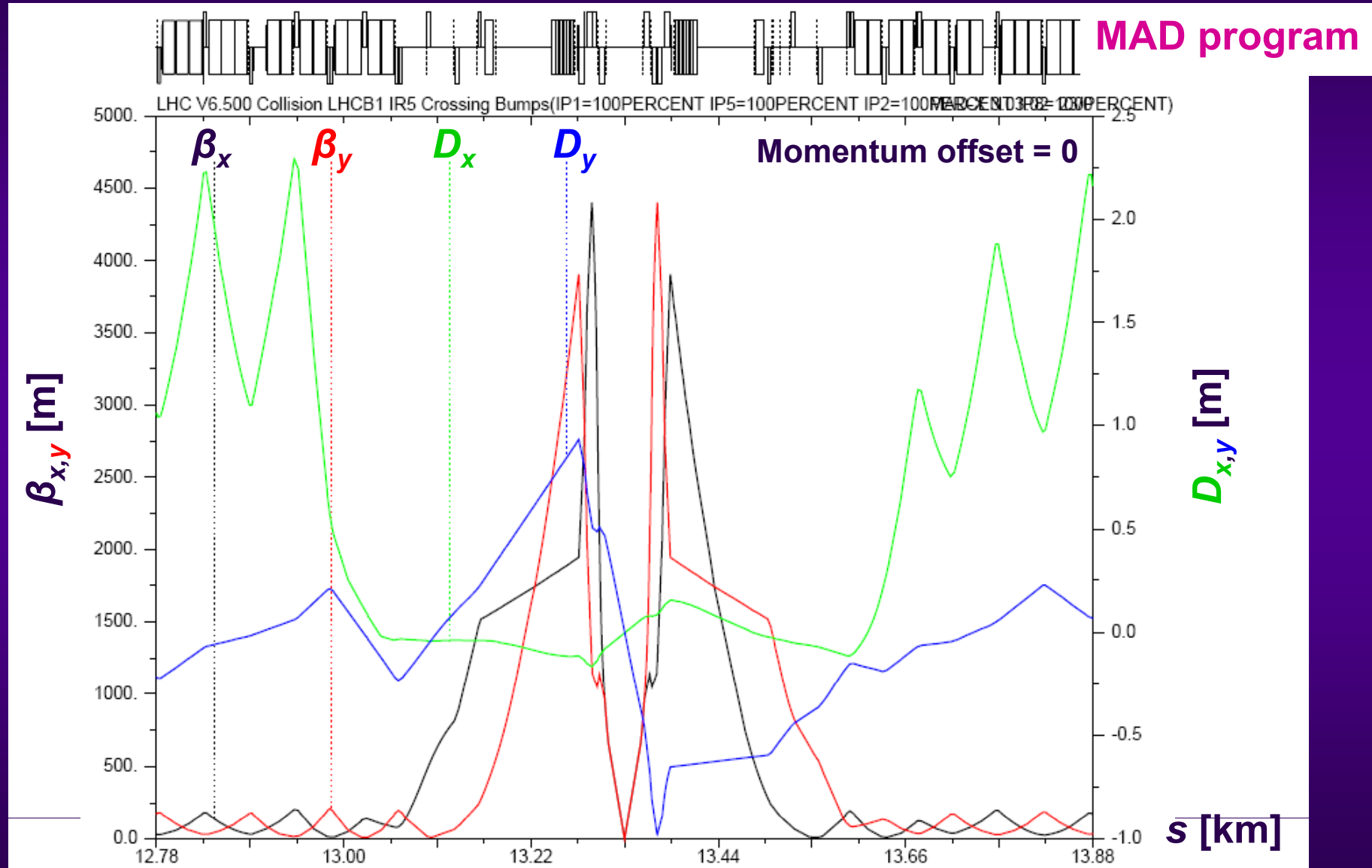

## TRANSVERSE BEAM DYNAMICS (14/27)

- ◆ **BEAM EMITTANCE = Measure of the spread in phase space of the points representing beam particles  $\Rightarrow$  3 definitions**

- 1) **In terms of the phase plane “amplitude”  $a_q$  enclosing  $q$  % of the particles**

$$\iint dx dx' = \pi \epsilon_x^{(q\%)}$$

ellipse of  
"amplitude"  $a_q$

[mm mrad] or [ $\mu\text{m}$ ]

- 2) **In terms of the 2<sup>nd</sup> moments of the particle distribution**

$$\epsilon_x^{(\text{stat})} \equiv \sqrt{\langle x^2 \rangle \langle x'^2 \rangle - \langle x x' \rangle^2}$$

Determinant of the  
covariance matrix

- 3) **In terms of  $\sigma_x$  the standard deviation of the particle distribution in real space (= projection onto the  $x$ -axis)**

$$\epsilon_x^{(\sigma_x)} \equiv \frac{\sigma_x^2}{\beta_x}$$

# TRANSVERSE BEAM DYNAMICS (15/27)

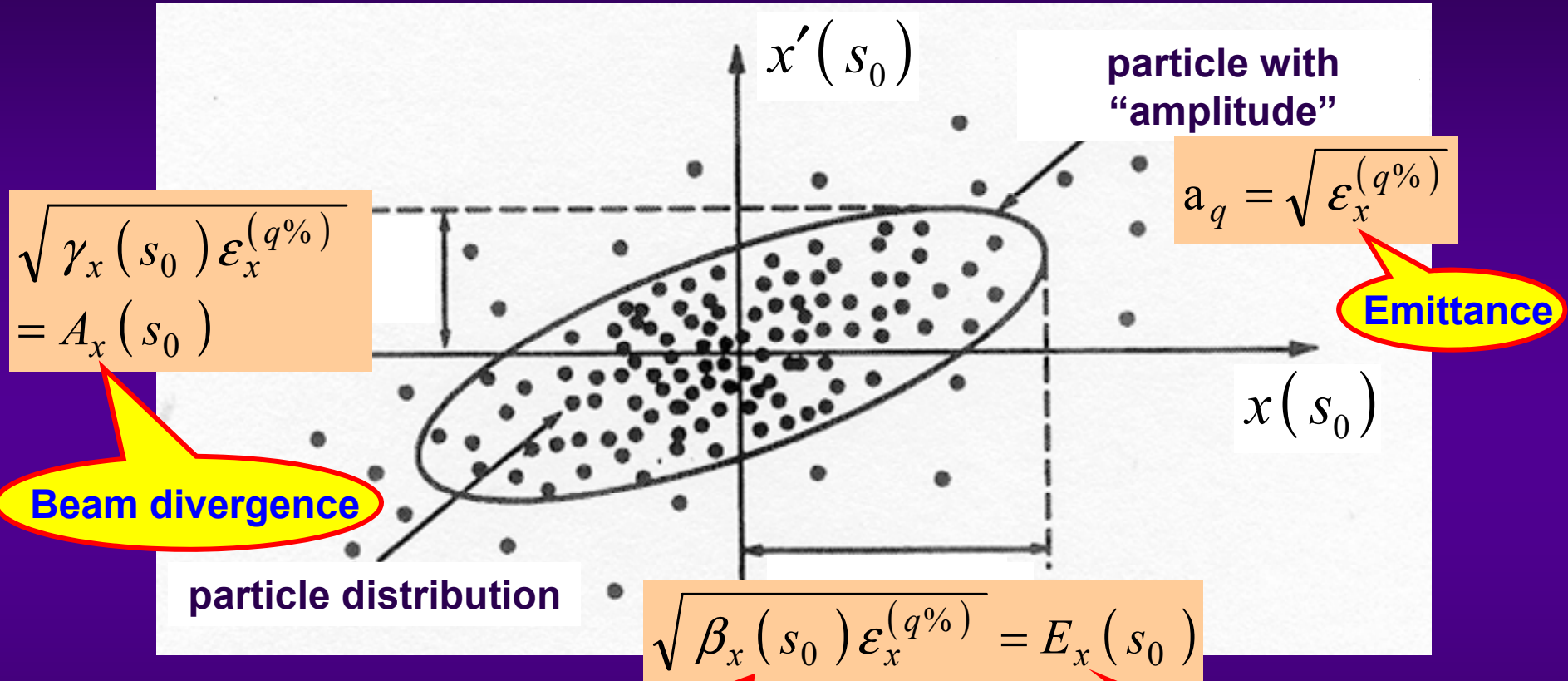

The  $\beta$ -function reflects the size of the beam and depends only on the lattice



## TRANSVERSE BEAM DYNAMICS (16/27)

- ◆ MACHINE mechanical (i.e. from the vacuum chamber) ACCEPTANCE or APERTURE = Maximum beam emittance
- ◆ NORMALIZED BEAM EMITTANCE

$$\varepsilon_{x,norm}^{(\sigma_x)} = \beta_r \gamma_r \varepsilon_x^{(\sigma_x)}$$

Relativistic factors

⇒ The normalized emittance is conserved during acceleration (in the absence of collective effects...)

- ◆ ADIABATIC DAMPING: As  $\beta_r \gamma_r$  increases proportionally to the particle momentum  $p$ , the (physical) emittance decreases as  $1 / p$
- ◆ However, many phenomena may affect (increase) the emittance
- ◆ An important challenge in accelerator technology is to preserve beam emittance and even to reduce it (by COOLING)

# TRANSVERSE BEAM DYNAMICS (17/27)

- ◆ **CHROMATICITY = Variation of the tune with the momentum**

$$Q'_x = \frac{\Delta Q_x}{\Delta p / p_0}$$

- ◆ **The control of the chromaticity (using a SEXTUPOLE magnet) is very important for 2 reasons**
  - **Avoid shifting the beam on resonances due to changes induced by chromatic effects (see later)**
  - **Prevent some transverse coherent (head-tail) instabilities (see also later)**

**SEXTUPOLE =  
1<sup>st</sup> nonlinear magnet**

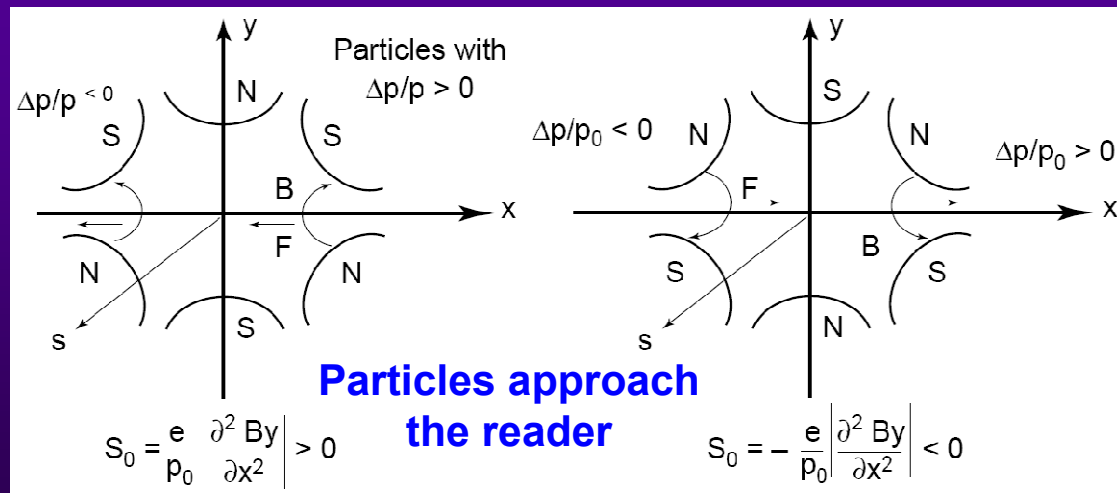

## TRANSVERSE BEAM DYNAMICS (18/27)

### ◆ Multipole magnetic FIELD EXPANSION (used for the LHC magnets)

$$B_y + j B_x = B_{ref} \sum_{n=1}^{\infty} [b_n + j a_n] \left( \frac{x + j y}{R_r} \right)^{n-1}$$

- $B_{ref}$  = magnetic field at the reference radius  $R_r = 17$  mm
- $n = 1 \Rightarrow$  dipole;  $n = 2 \Rightarrow$  quadrupole;  $n = 3 \Rightarrow$  sextupole...
- $b_n \Rightarrow$  normal harmonics
- $a_n \Rightarrow$  skew harmonics (the skew magnets differ from the regular magnets only by a rotation about the s-axis by an angle  $\pi / 2n$ , where  $n$  is the order of the multipole)

## TRANSVERSE BEAM DYNAMICS (19/27)

- ◆ In the presence of extra (NONLINEAR) FORCES, the Hill's equation takes the general form

$$x''(s) + K_x(s)x(s) = P_x(x, y, s)$$

Any perturbation

- ◆ Perturbation terms in the equation of motion may lead to UNSTABLE motion, called RESONANCES, when the perturbing field acts in synchronism with the particle oscillations
- ◆ A multipole of  $n$ th order is said to generate resonances of order  $n$ . Resonances below the 3<sup>rd</sup> order (i.e. due to dipole and quadrupole field errors for instance) are called LINEAR RESONANCES. The NONLINEAR RESONANCES are those of 3<sup>rd</sup> order and above

## TRANSVERSE BEAM DYNAMICS (20/27)

- ◆ **General RESONANCE CONDITIONS**  $M Q_x + N Q_y = P$

where  $M$ ,  $N$  and  $P$  are integers,  $P$  being non-negative,  $|M| + |N|$  is the order of the resonance and  $P$  is the order of the perturbation harmonic

- ◆ **Plotting the resonance lines for different values of  $M$ ,  $N$ , and  $P$  in the  $(Q_x, Q_y)$  plane yields the so-called RESONANCE or TUNE DIAGRAM**

This dot in the tune diagram is called the **WORKING POINT** (case of the PS, here)

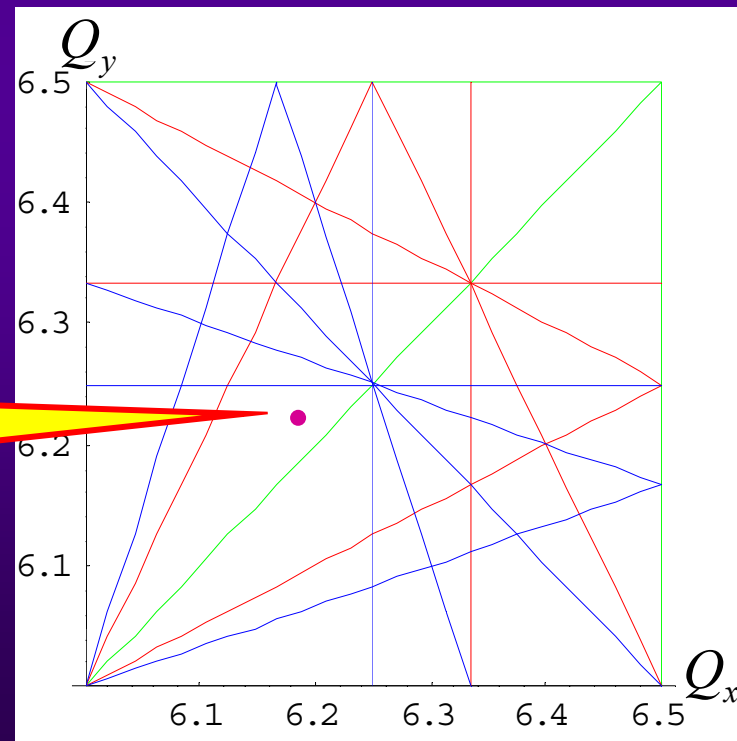

## TRANSVERSE BEAM DYNAMICS (21/27)

- ◆ **RESONANCE WIDTH = Band with some thickness around every resonance line in the resonance diagram, in which the motion may be unstable, depending on the oscillation amplitude**
- ◆ **STOPBAND = Resonance width when the resonance is linear (i.e. below the 3<sup>rd</sup> order), because the entire beam becomes unstable if the operating point ( $Q_x, Q_y$ ) reaches this region of tune values**
- ◆ **DYNAMIC APERTURE = Largest oscillation amplitude which is stable in the presence of nonlinearities**
- ◆ **TRACKING: In general, the equations of motion in the presence of nonlinear fields are untractable for any but the simplest situations. Tracking consists to simulate (user computer programs such as MAD) particle motion in circular accelerators in the presence of nonlinear fields**



## TRANSVERSE BEAM DYNAMICS (22/27)

- ◆ **KICK MODEL:** Any nonlinear magnet is treated in the “point-like” approximation (i.e. the particle position is assumed not to vary as the particle traverses the field), the motion in all other elements of the lattice is assumed to be linear. Thus, at each turn the local magnetic field gives a “kick” to the particle, deflecting it from its unperturbed trajectory

- ◆ **HENON MAPPING**  
= Stroboscopic representation of phase-space trajectories (normalised  $\Rightarrow$  circles instead of ellipses for linear motion) on every machine turn at the fixed azimuthal position of the perturbation

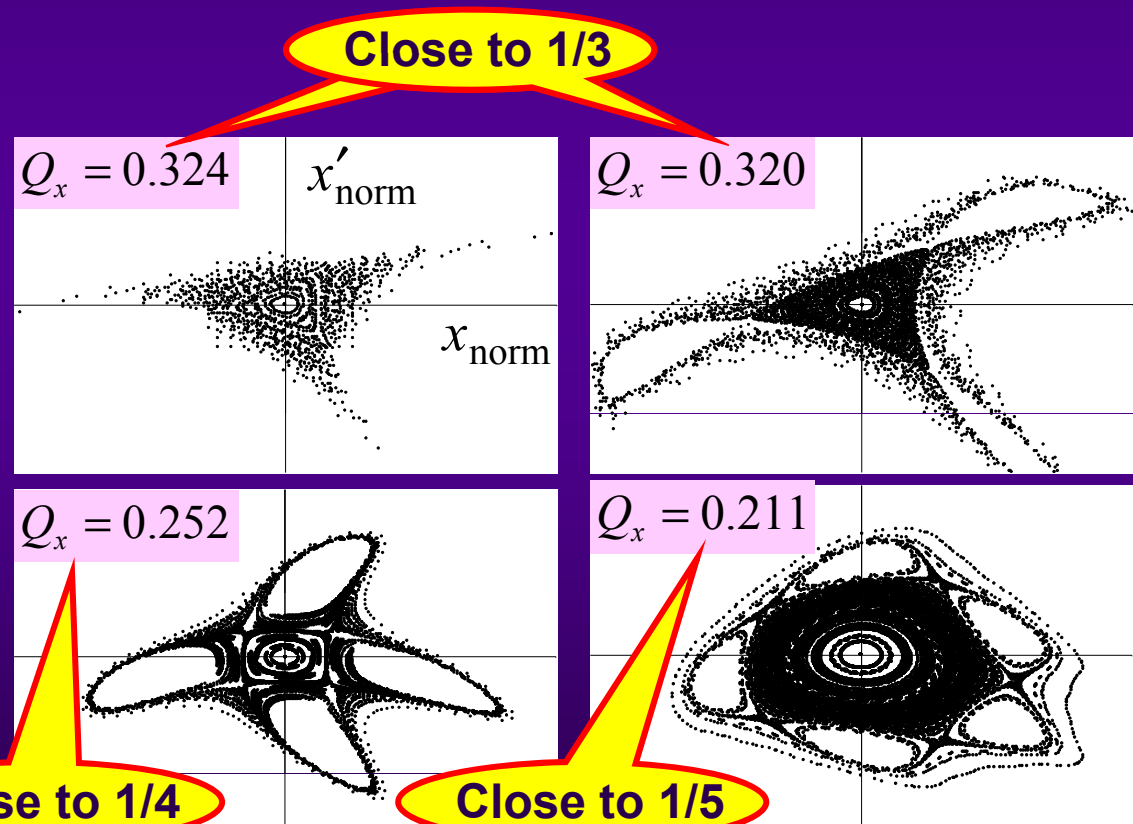

## TRANSVERSE BEAM DYNAMICS (23/27)

- ◆ **SEPARATRICES** define boundaries between stable motion (bounded oscillations) and unstable motion (expanding oscillations)
- ◆ The 3<sup>rd</sup> order resonance is a drastic (unstable) one because the particles which go onto this resonance are lost
- ◆ **(STABLE) ISLANDS:** For the higher order resonances (e.g. 4<sup>th</sup> and 5<sup>th</sup>) stable motions are also possible in (stable) islands. There are 4 stable islands when the tune is closed to a 4<sup>th</sup> order resonance and 5 when it is closed to a 5<sup>th</sup> order resonance

## TRANSVERSE BEAM DYNAMICS (24/27)

- ◆ (fast) EXTRACTION **from a ring**

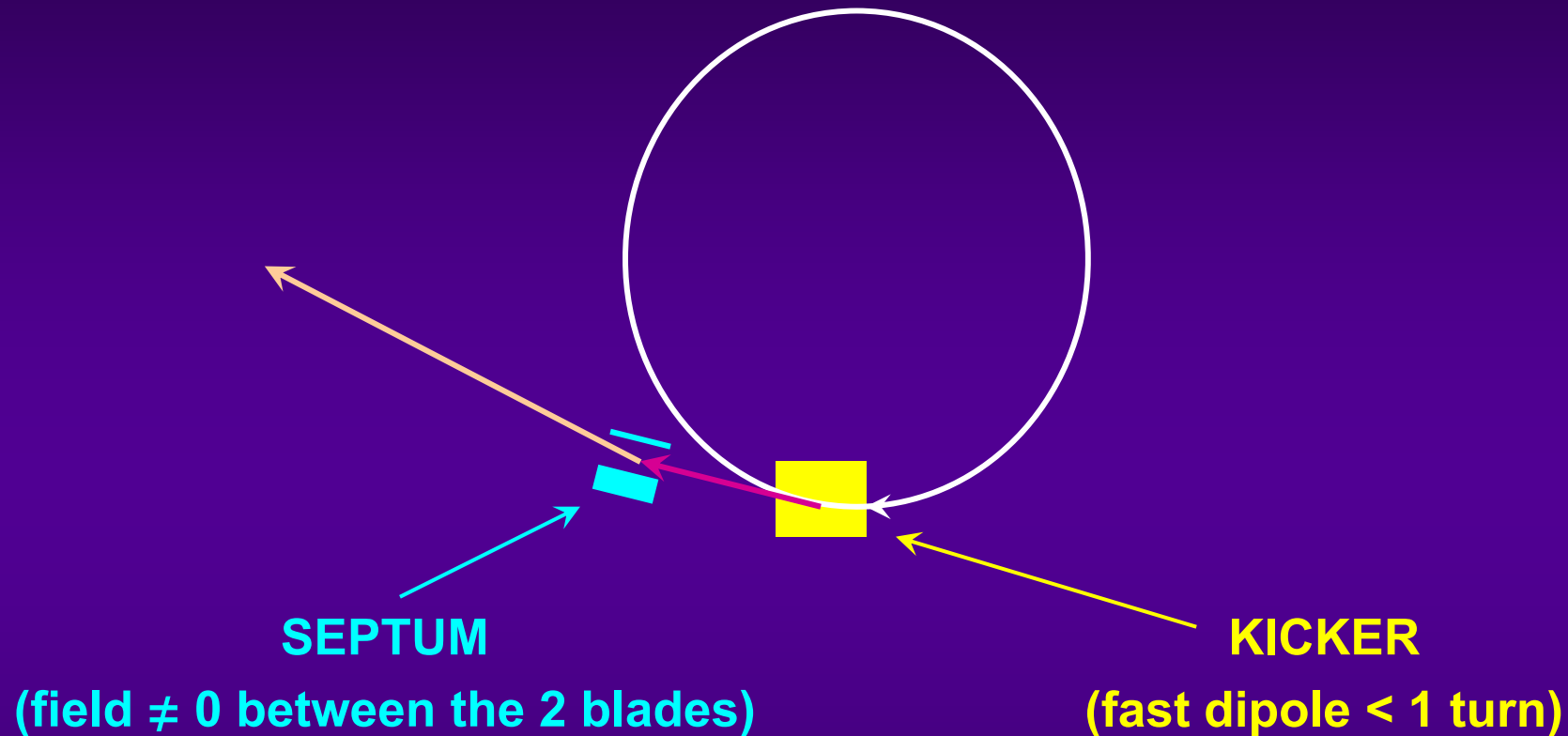

- ◆ (fast) INJECTION **into a ring**  $\Rightarrow$  Reverse process

# TRANSVERSE BEAM DYNAMICS (25/27)

Many other injection & ejection schemes  $\Rightarrow$  Example of another extraction

Tune variation

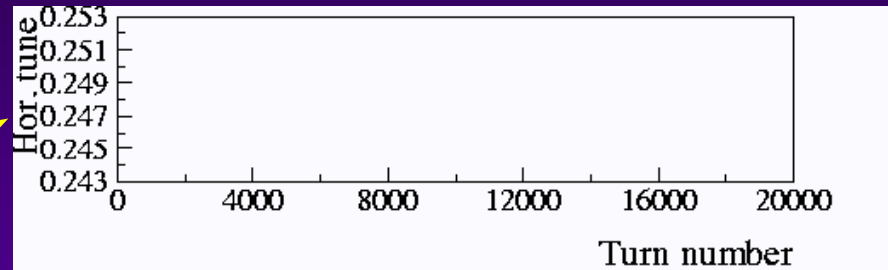

Phase space portrait

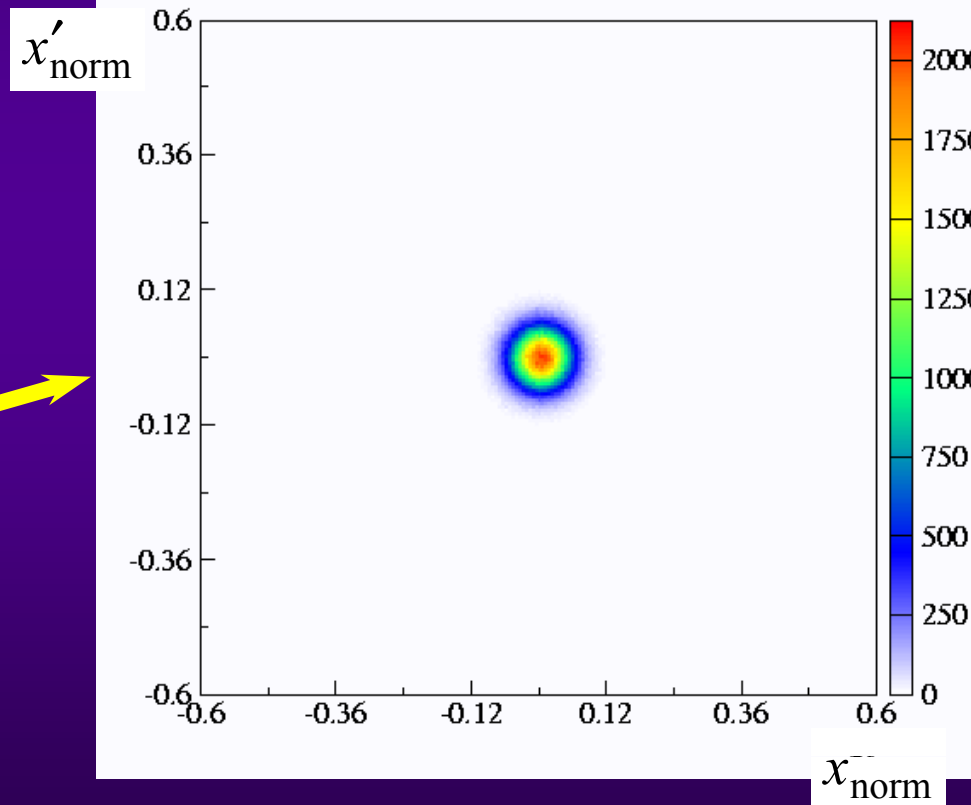

Simulation for the  
NEW PS MULTI-  
TURN EXTRACTION  
(in commissioning)

Courtesy  
M. Giovannozzi

# TRANSVERSE BEAM DYNAMICS (26/27)

Final stage after 20000 turns (about 42 ms for the PS)

The particles here are extracted through the TT2 transfer line

At the extraction septum location

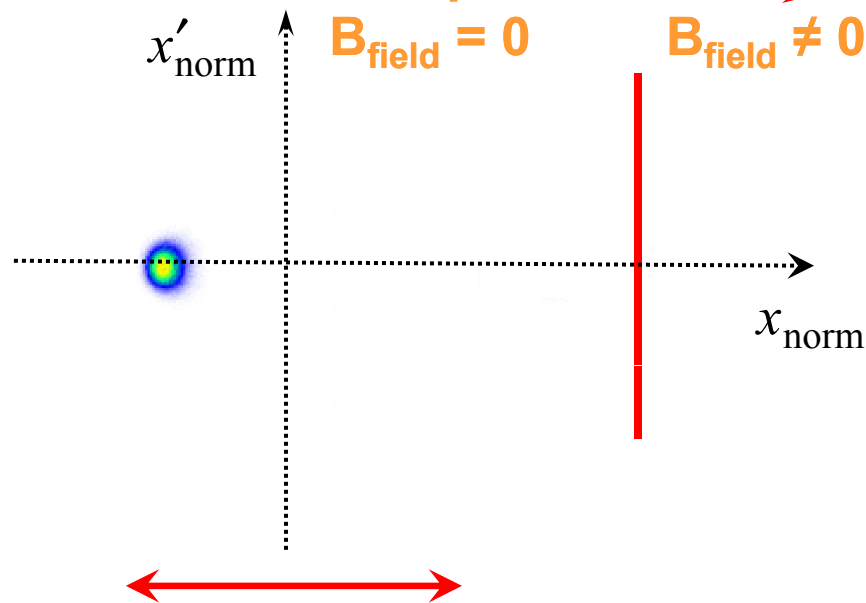

Slow (few thousand turns) bump first (closed distortion of the periodic orbit)

Fast (less than one turn) bump afterwards (closed distortion of the periodic orbit)

About 6 cm in physical space

Courtesy  
M. Giovannozzi

## TRANSVERSE BEAM DYNAMICS (27/27)

- ◆ **BETATRON MATCHING** = The phase space ellipses at the injection (ejection) point of the circular machine, and the exit (entrance) of the beam transport line, should be homothetic. To do this, the Twiss parameters are modified using quadrupoles. If the ellipses are not homothetic, there will be a dilution (i.e. a BLOW-UP) of the emittance

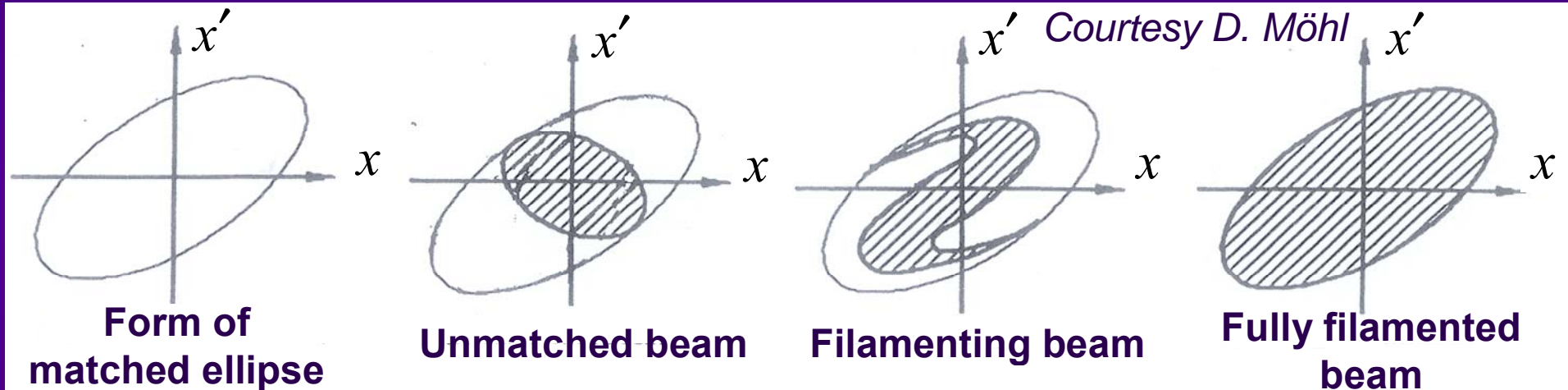

- ◆ **DISPERSION MATCHING** =  $D_x$  and  $D'_x$  should be the same at the injection (ejection) point of the circular machine, and the exit (entrance) of the beam transport line. If there are different, there will be also a BLOW-UP, but due to a missteering (because the beam is not injected on the right orbit)



# LONGITUDINAL BEAM DYNAMICS (1/12)

- ◆ The electric field is used to accelerate or decelerate the particles, and is produced by one or more RF (Radio-Frequency) CAVITIES

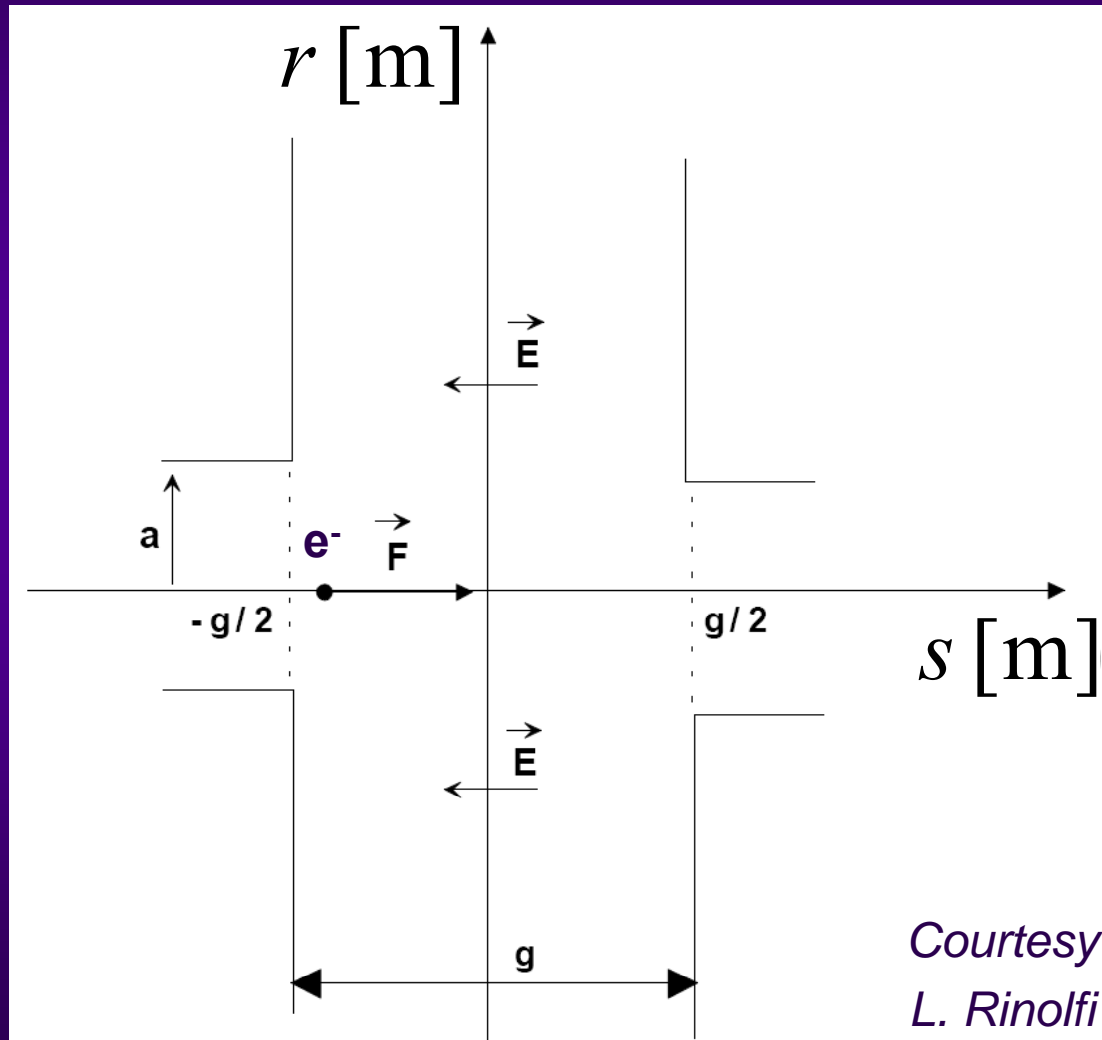

$$\Delta E = e \int_{-g/2}^{g/2} E_s(s, t) ds$$

[eV]

[V/m]

Courtesy  
L. Rinolfi

# LONGITUDINAL BEAM DYNAMICS (2/12)

2 ferrite loaded cylinders that permit the cavity to be tuned

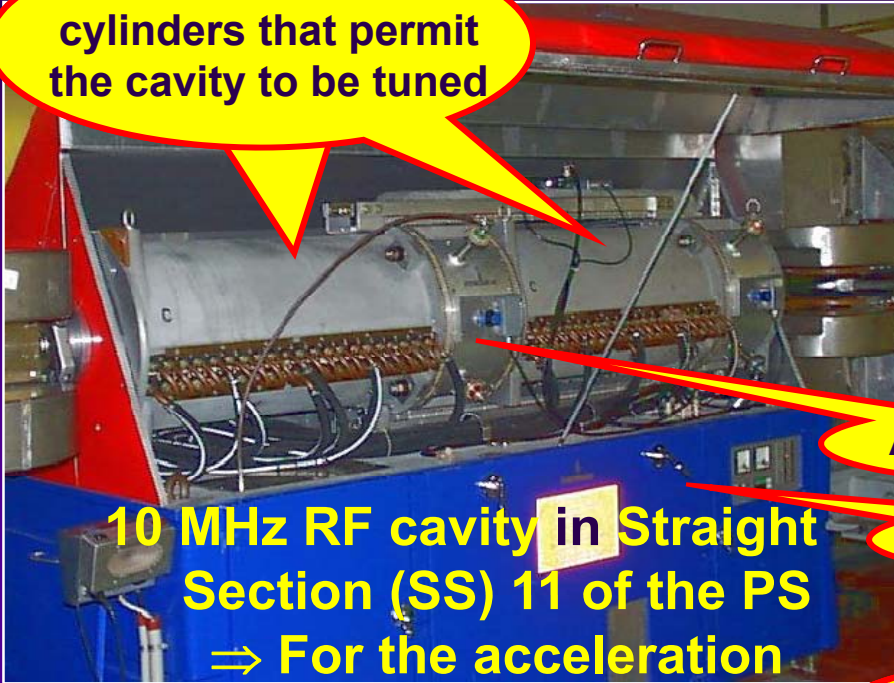

10 MHz RF cavity in Straight Section (SS) 11 of the PS  
⇒ For the acceleration

Accelerating gap

Final power amplifier



Six 200 MHz in SS6

RF gymnastics



13 MHz in SS92



40 MHz in SS78



80 MHz in SS13

## LONGITUDINAL BEAM DYNAMICS (3/12)

- ◆ **TRANSITION ENERGY: The increase of energy has 2 contradictory effects**
  - **An increase of the particle's velocity**
  - **An increase of the length of the particle's trajectory**

**According to the variations of these 2 parameters, the revolution frequency evolves differently**

- **Below transition energy: The velocity increases faster than the length  $\Rightarrow$  The revolution frequency increases**
- **Above transition energy: It is the opposite case  $\Rightarrow$  The revolution frequency decreases**
- **At transition energy: The variation of the velocity is compensated by the variation of the trajectory  $\Rightarrow$  A variation of energy does not modify the frequency**

# LONGITUDINAL BEAM DYNAMICS (4/12)

◆ Sinusoidal voltage applied

$$V_{\text{RF}} = \hat{V}_{\text{RF}} \sin \phi_{\text{RF}}(t)$$

$$\omega_{\text{RF}} = h \omega_{\text{rev}}$$

$$\Rightarrow \Delta E_1 = e \hat{V}_{\text{RF}} \sin \phi_1$$

Harmonic number

BUNCHED beam in a stationary BUCKET

SYNCHROTRON OSCILLATION  
(here, below transition)

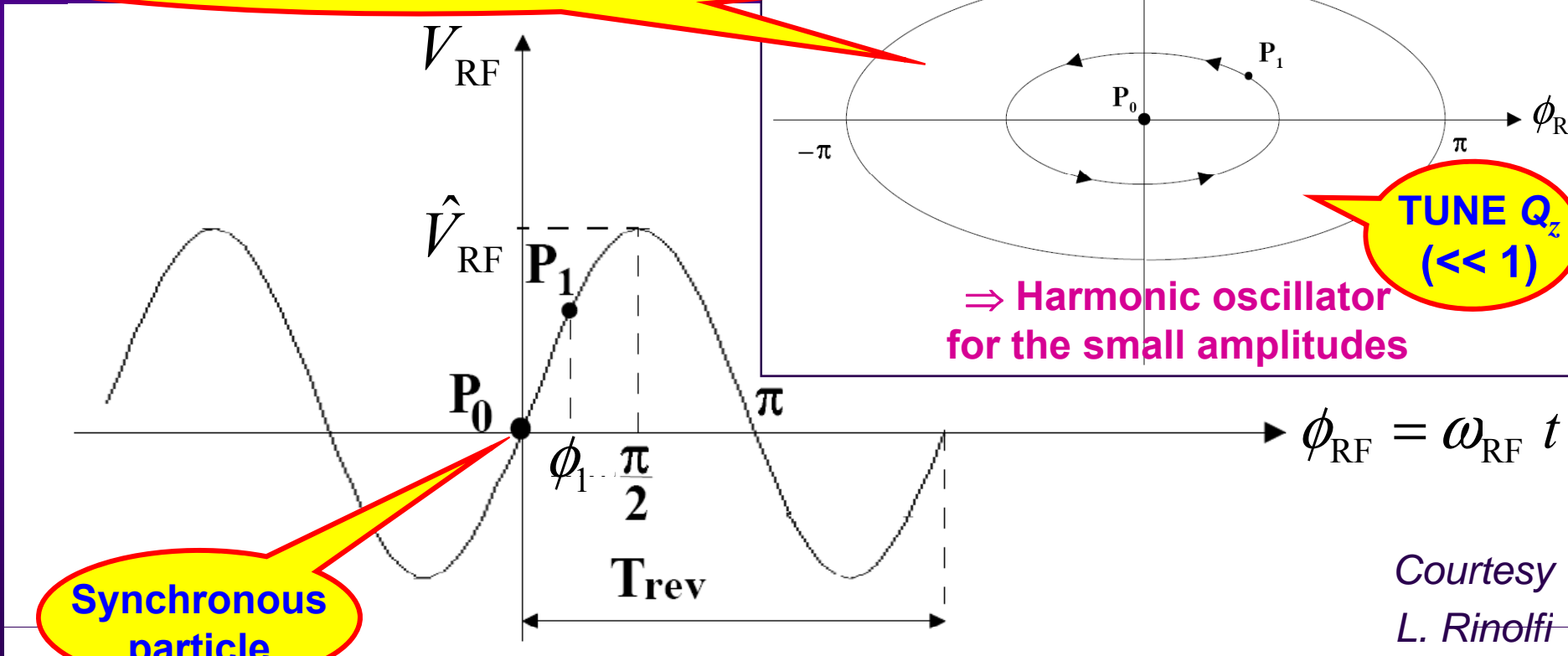
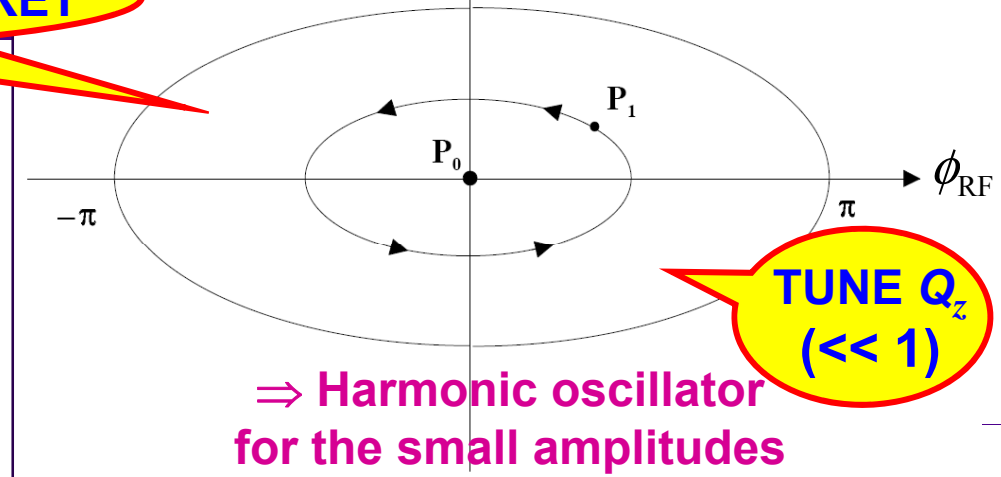

Courtesy  
L. Rinolfi

# LONGITUDINAL BEAM DYNAMICS (5/12)

Synchronous phase

- ◆ Synchrotron oscillation during acceleration (below transition)

$$\phi_1 = \phi_s \neq 0$$

Above transition, the stable phase is  $\pi - \phi_s$

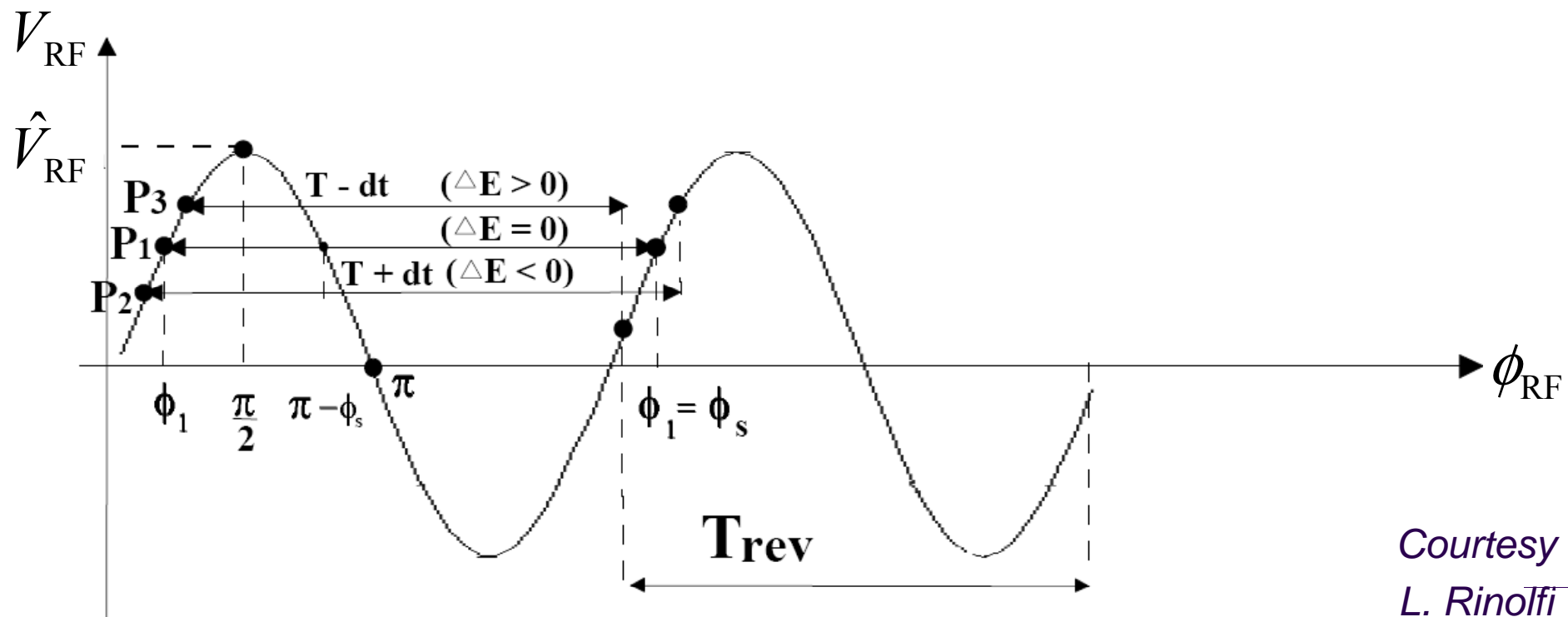

Courtesy  
L. Rinolfi



# LONGITUDINAL BEAM DYNAMICS (6/12)

Courtesy  
L. Rinolfi

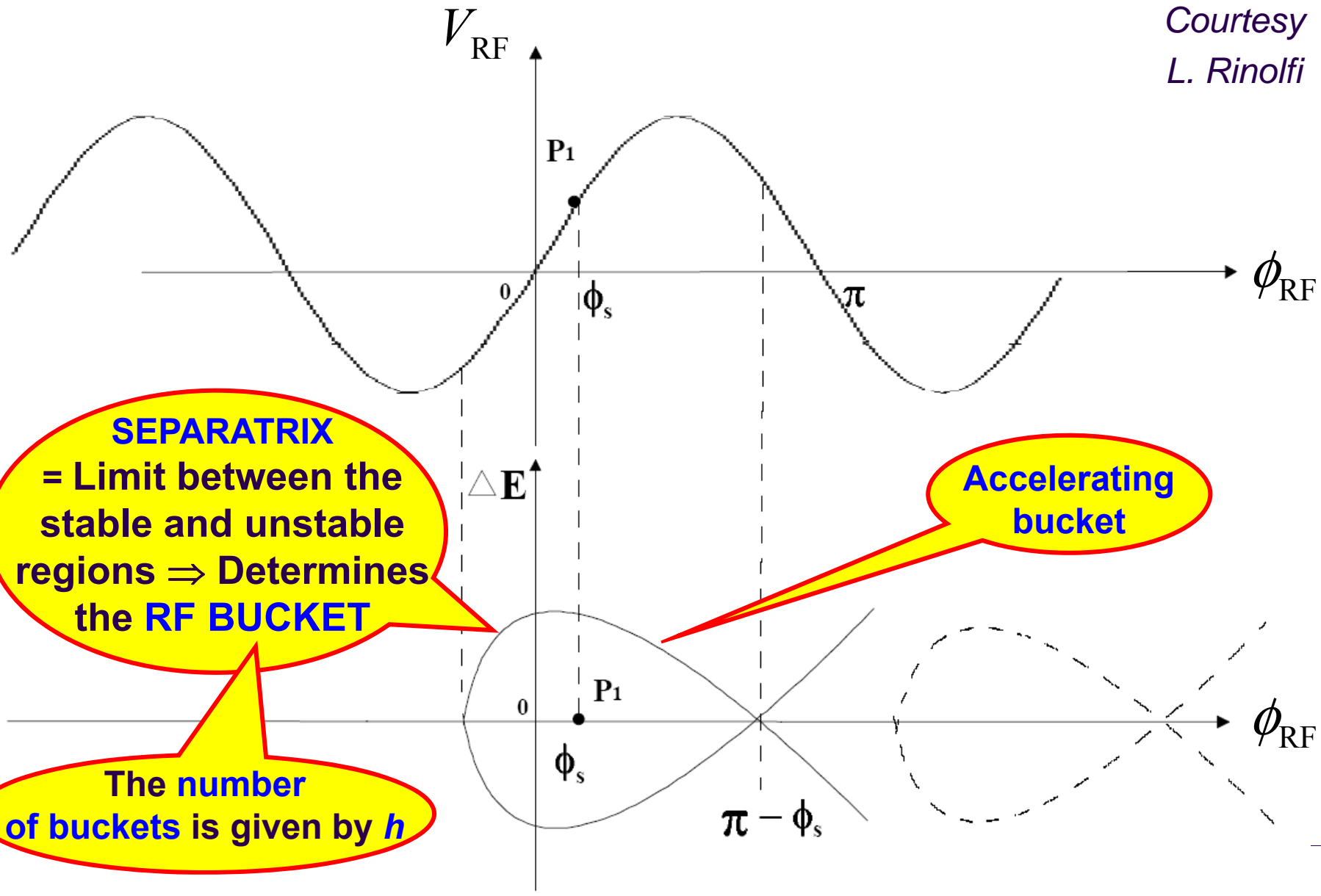

**SEPARATRIX**  
= Limit between the stable and unstable regions  $\Rightarrow$  Determines the **RF BUCKET**

**Accelerating bucket**

The number of buckets is given by  $h$

## LONGITUDINAL BEAM DYNAMICS (7/12)

⇒  $\ddot{\tau}(t) + \omega_s^2 \tau(t) = 0$  : **Equation of a harmonic oscillator**

$\tau$  = Time interval between the passage of the synchronous particle and the particle under consideration

$$\omega_s = \sqrt{\frac{|\eta \cos \phi_s| \hat{V}_{\text{RF}} h}{2\pi \beta_r^2 (E/e)}} \omega_{\text{rev}}$$

$$\eta = \gamma_{tr}^{-2} - \gamma_r^{-2} = (\Delta T / T_0) / (\Delta p / p_0)$$

= Momentum compaction factor  $\alpha_p$

Slip factor (sometimes defined with a negative sign...)

⇒  $Q_z = \frac{\omega_s}{\omega_{\text{rev}}}$  : **Synchrotron tune**

Number of synchrotron oscillations per machine revolution

# LONGITUDINAL BEAM DYNAMICS (8/12)

TOMOSCOPE (developed by S. Hancock, CERN/AB/RF)

The aim of TOMOGRAPHY is to estimate an unknown distribution (here the 2D longitudinal distribution) using only the information in the bunch profiles (see Beam control)

Surface = Longitudinal EMITTANCE of the bunch =  $\epsilon_L$  [eV.s]

Surface = Longitudinal ACCEPTANCE of the bucket

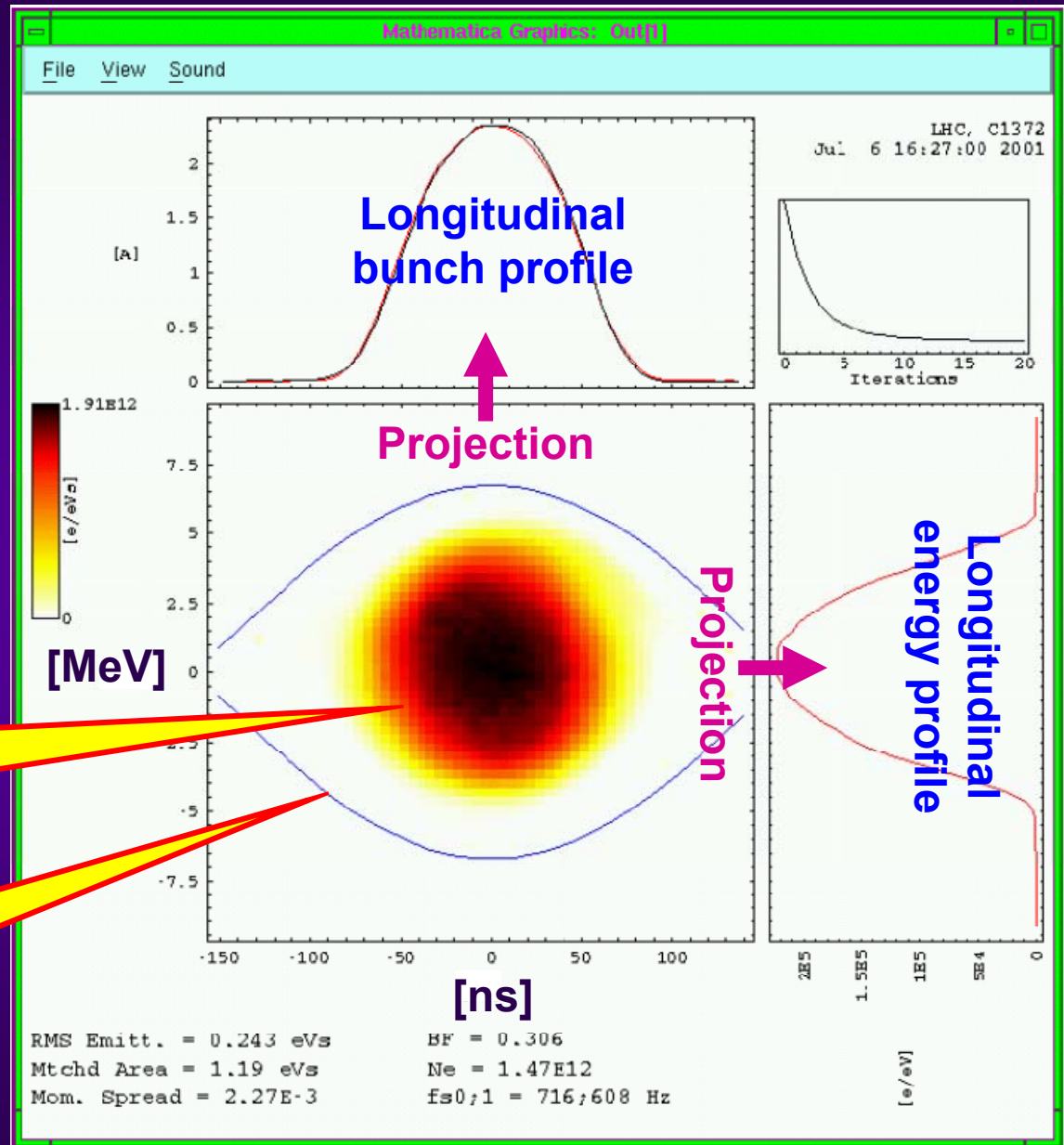



# LONGITUDINAL BEAM DYNAMICS (9/12)

## Examples of RF gymnastics

### Longitudinal BUNCH SPLITTING

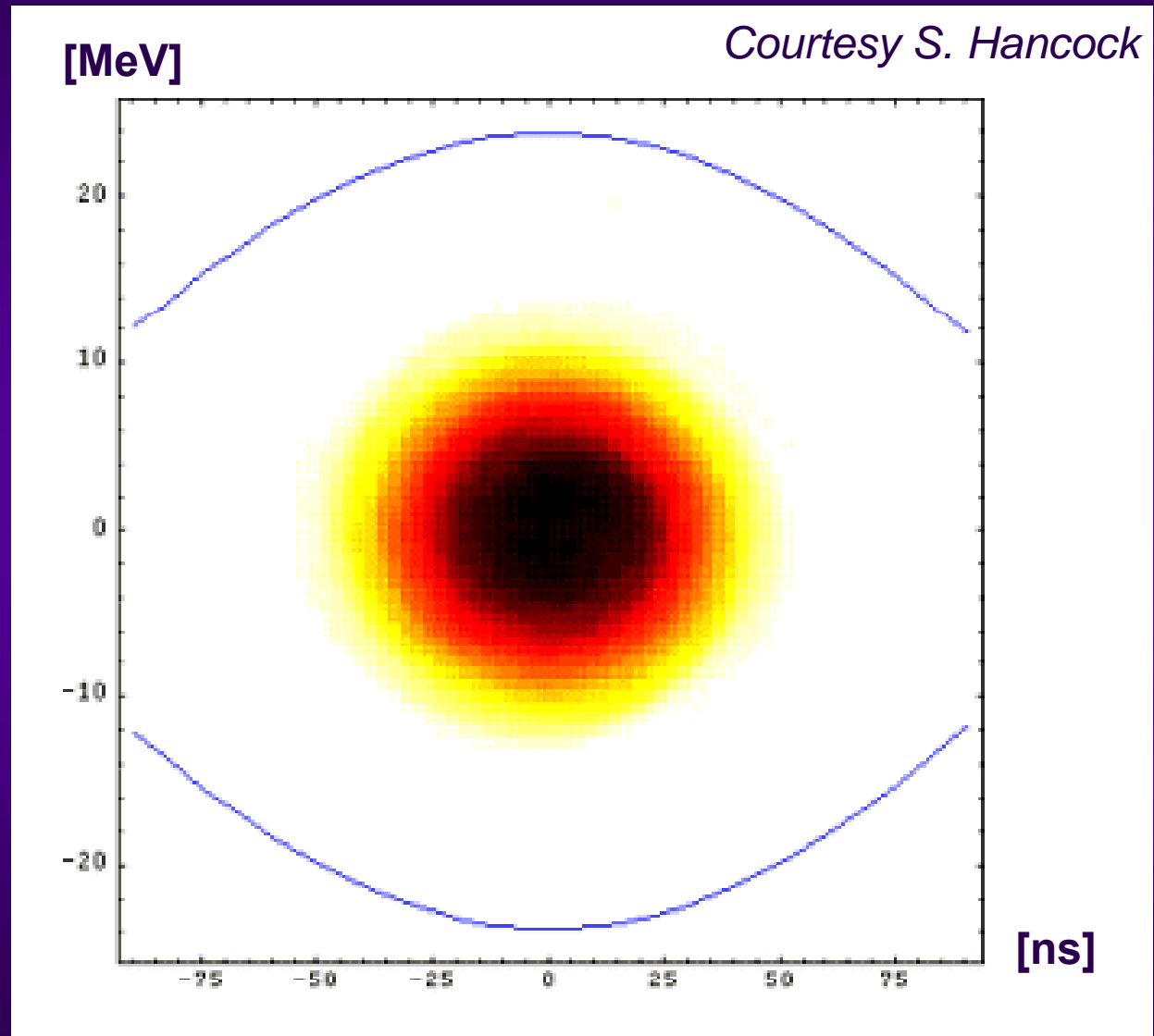

# LONGITUDINAL BEAM DYNAMICS (10/12)

Triple bunch  
splitting

Courtesy  
R. Garoby

1 trace / 356 revolutions ( $\sim 800 \mu\text{s}$ )

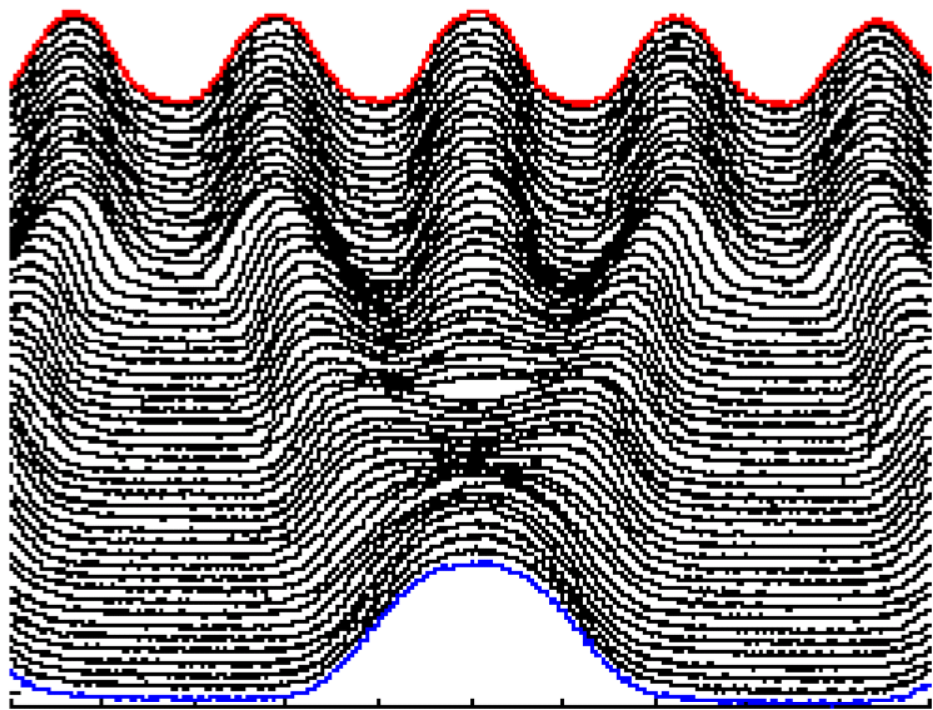

50 ns/div

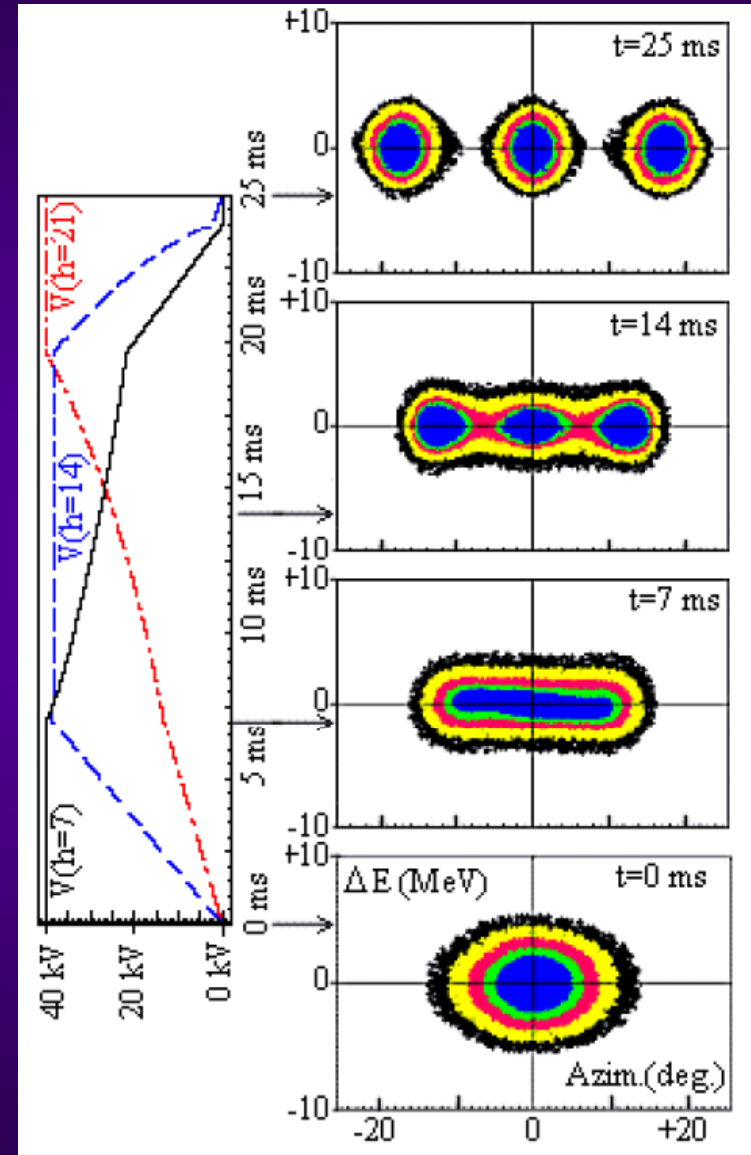

# LONGITUDINAL BEAM DYNAMICS (11/12)

$\frac{\Delta p}{p_0} = 3.8\%$

BUNCH ROTATION WITH LONGITUDINAL SPACE-CHARGE  
TURN 0 0.000E+00 sec

$H_0$ [MeV]	$S_0$ [eV s]	$E_0$ [MeV]	$h$	$v$ [DMV]	$\psi$ [deg]
6.9592E+00	1.2240E+00	2.9383E+03	24	6.923E-02	0.000E+00
$\nu_s$ [turn <sup>-1</sup> ]	$\beta$ [MeV s <sup>-1</sup> ]	$\eta$			
3.1861E-03	0.0000E+00	-1.0003E-01			
$\tau$ [e]	$S_0$ [eV s]	$N$			
3.3175E-06	3.1000E-01	20000			

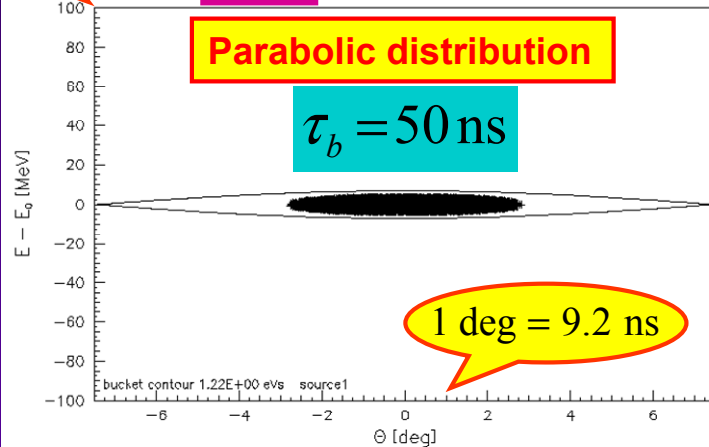

BUNCH ROTATION WITH LONGITUDINAL SPACE-CHARGE  
THRMS VS TIME

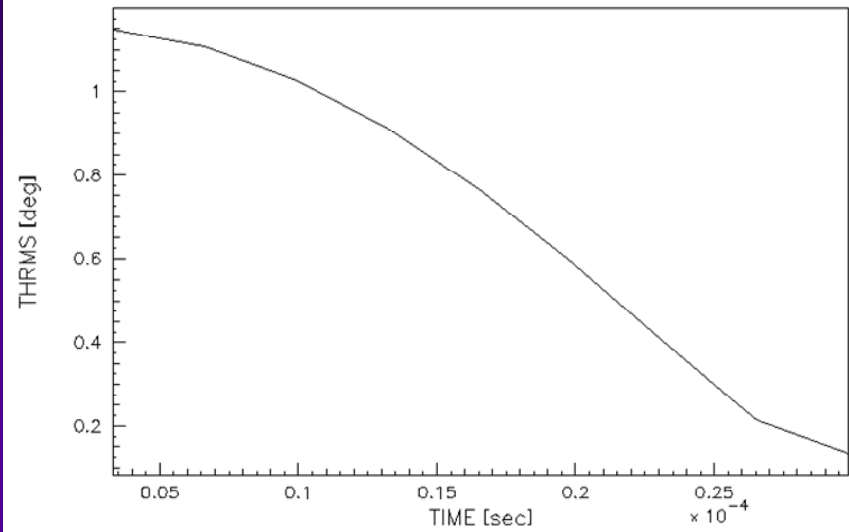

## BUNCH ROTATION (with ESME)

BUNCH ROTATION WITH LONGITUDINAL SPACE-CHARGE  
TURN 9 2.986E-05 sec

$H_0$ [MeV]	$S_0$ [eV s]	$E_0$ [MeV]	$h$	$v$ [DMV]	$\psi$ [deg]
6.8404E+01	1.1339E+01	2.9383E+03	24	7.000E+00	0.000E+00
$\nu_s$ [turn <sup>-1</sup> ]	$\beta$ [MeV s <sup>-1</sup> ]	$\eta$			
3.1837E-02	0.0000E+00	-1.0003E-01			
$\tau$ [e]	$S_0$ [eV s]	$N$			
3.3175E-06	3.1884E-01	20000			

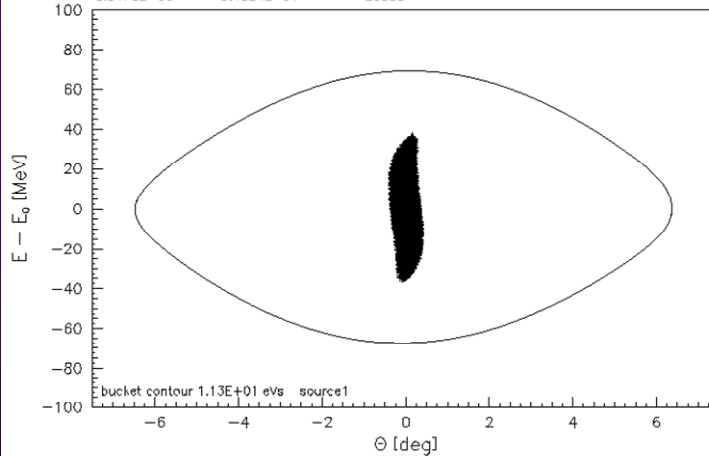

BUNCH ROTATION WITH LONGITUDINAL SPACE-CHARGE  
ERMS VS TIME

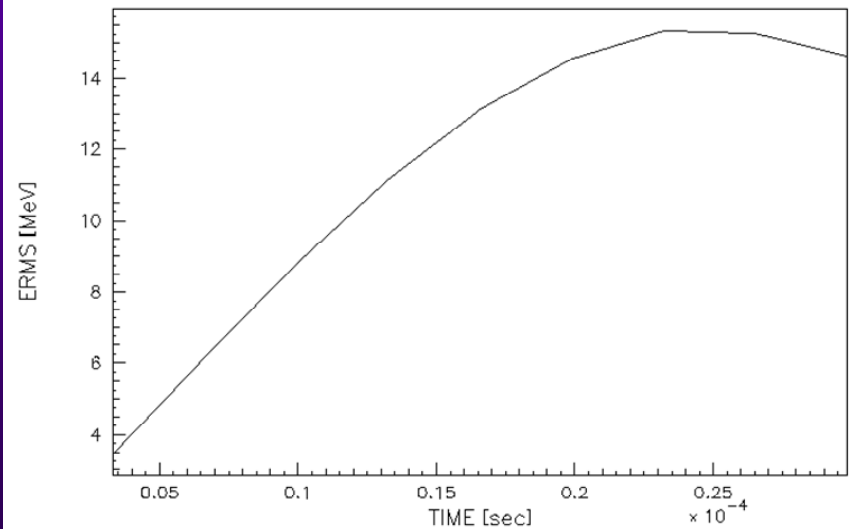

## LONGITUDINAL BEAM DYNAMICS (12/12)

### ◆ EXTRACTION **AND** LONGITUDINAL MATCHING

⇒ The RF buckets (expressed in energy vs. time) of the 2 rings should be homothetic ( $\Delta E / \Delta t$  conserved), otherwise longitudinal BLOW-UP

# FIGURE OF MERIT FOR A SYNCHROTRON / COLLIDER: BRIGHTNESS / LUMINOSITY (1/6)

## ◆ (2D) BEAM BRIGHTNESS

$$B = \frac{I}{\pi^2 \epsilon_x \epsilon_y}$$

Beam current

Transverse emittances

## ◆ MACHINE LUMINOSITY

$$L = \frac{N_{\text{events/second}}}{\sigma_{\text{event}}}$$

Number of events per second  
generated in the collisions

Cross-section for the event  
under study

[cm<sup>-2</sup> s<sup>-1</sup>]

- The Luminosity depends only on the beam parameters  
⇒ It is independent of the physical reaction
- Reliable procedures to compute and measure

# FIGURE OF MERIT FOR A SYNCHROTRON / COLLIDER: BRIGHTNESS / LUMINOSITY (2/6)

⇒ For a Gaussian (round) beam distribution

Number of particles  
per bunch

Number of  
bunches per beam

Revolution  
frequency

Relativistic  
velocity factor

$$L = \frac{N_b^2 M f_{rev} \gamma_r}{4 \pi \varepsilon_n \beta^*} F$$

Normalized  
transverse beam  
emittance

Geometric reduction  
factor due to the crossing angle  
at the IP

$\beta$ -function at the  
collision point

◆ PEAK LUMINOSITY for ATLAS&CMS in the LHC =

$$L_{peak} = 10^{34} \text{ cm}^{-2} \text{ s}^{-1}$$

## FIGURE OF MERIT FOR A SYNCHROTRON / COLLIDER: BRIGHTNESS / LUMINOSITY (3/6)

Number of particles per bunch	$N_b$	$1.15 \times 10^{11}$
Number of bunches per beam	$M$	2808
Revolution frequency	$f_{rev}$	11245 Hz
Relativistic velocity factor	$\gamma_r$	7461 ( $\Rightarrow E = 7$ TeV)
$\beta$ -function at the collision point	$\beta^*$	55 cm
Normalised rms transverse beam emittance	$\epsilon_n$	$3.75 \times 10^{-4}$ cm
Geometric reduction factor	$F$	0.84

$$F = 1 / \sqrt{1 + \left( \frac{\theta_c \sigma_z}{2\sigma^*} \right)^2}$$

Full crossing angle at the IP	$\theta_c$	285 $\mu$ rad
Rms bunch length	$\sigma_z$	7.55 cm
Transverse rms beam size at the IP	$\sigma^*$	16.7 $\mu$ m

## FIGURE OF MERIT FOR A SYNCHROTRON / COLLIDER: BRIGHTNESS / LUMINOSITY (4/6)

### ◆ INTEGRATED LUMINOSITY

$$L_{\text{int}} = \int_0^T L(t) dt$$

⇒ **The real figure of merit =**  $L_{\text{int}} \sigma_{\text{event}} = \text{number of events}$

### ◆ **LHC integrated Luminosity expected per year: [80-120] fb<sup>-1</sup>**

**Reminder: 1 barn = 10<sup>-24</sup> cm<sup>2</sup>  
and femto = 10<sup>-15</sup>**



## FIGURE OF MERIT FOR A SYNCHROTRON / COLLIDER: BRIGHTNESS / LUMINOSITY (5/6)

- ◆ **The total proton-proton cross section at 7 TeV is ~ 110 mbarns:**
  - **Inelastic**  $\Rightarrow \sigma_{in} = 60$  mbarns
  - **Single diffractive**  $\Rightarrow \sigma_{sd} = 12$  mbarns
  - **Elastic**  $\Rightarrow \sigma_{el} = 40$  mbarns
- ◆ **The cross section from elastic scattering of the protons and diffractive events will not be seen by the detectors as it is only the inelastic scatterings that give rise to particles at sufficient high angles with respect to the beam axis**
- ◆ **Inelastic event rate at nominal luminosity =  $10^{34} \times 60 \times 10^{-3} \times 10^{-24} = 600$  millions / second per high-luminosity experiment**

## FIGURE OF MERIT FOR A SYNCHROTRON / COLLIDER: BRIGHTNESS / LUMINOSITY (6/6)

- ◆ **The bunch spacing in the LHC is 25 ns  $\Rightarrow$  Crossing rate of 40 MHz**
- ◆ **However, there are bigger gaps (for the kickers)  $\Rightarrow$  Average crossing rate = number of bunches  $\times$  revolution frequency =  $2808 \times 11245 = 31.6$  MHz**
- ◆ **(600 millions inelastic events / second) / ( $31.6 \times 10^6$ ) = 19 inelastic events per crossing**
- ◆ **Total inelastic events per year ( $\sim 10^7$  s) =  $600 \text{ millions} \times 10^7 = 6 \times 10^{15} \sim 10^{16}$**
- ◆ **The LHC experimental challenge is to find rare events at levels of 1 in  $10^{13}$  or more  $\Rightarrow$   $\sim 1000$  Higgs events in each of the ATLAS and CMS experiments expected per year**

## BEAM CONTROL (1/8)

- ◆ **New CERN Control Centre (CCC) at Preveessin since March 2006**

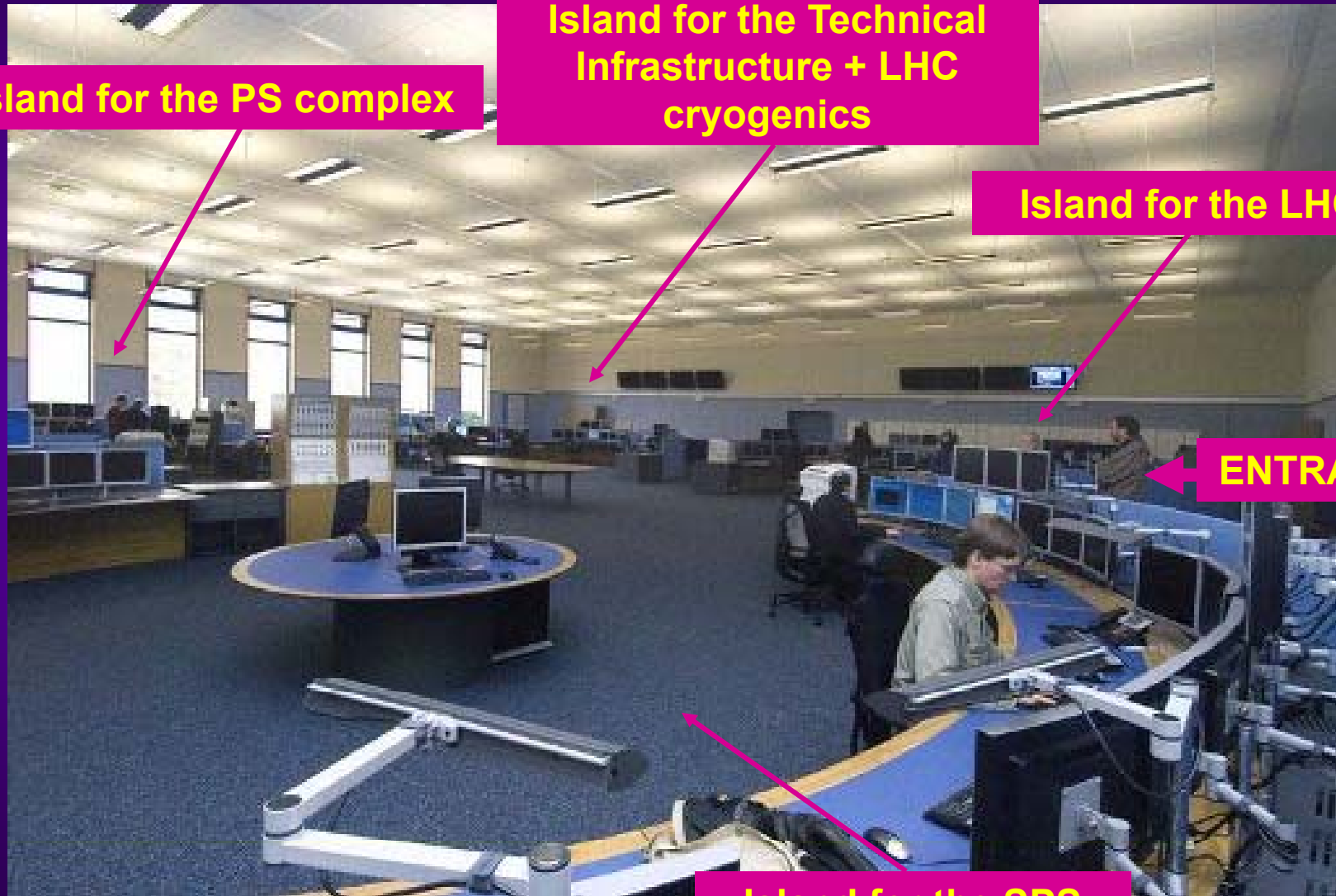

## BEAM CONTROL (2/8)

- ◆ **WALL CURRENT MONITOR = Device used to measure the instantaneous value of the beam current**

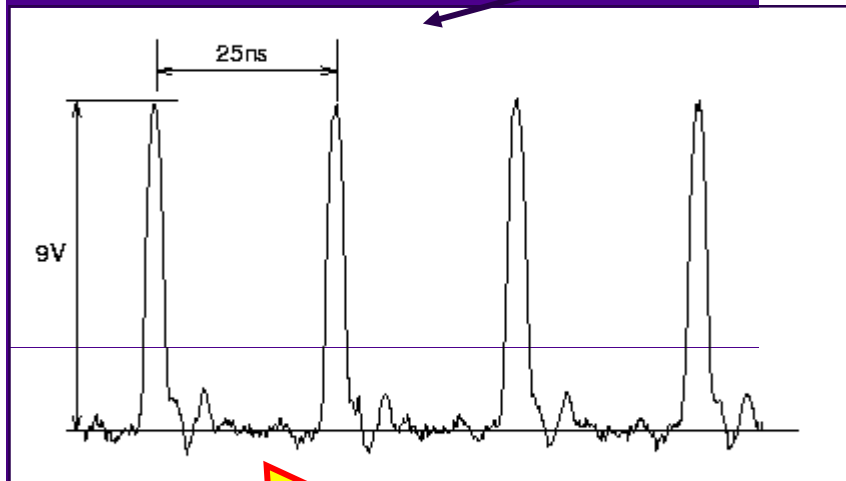

**Longitudinal bunch profiles for a LHC-type beam in the PS**

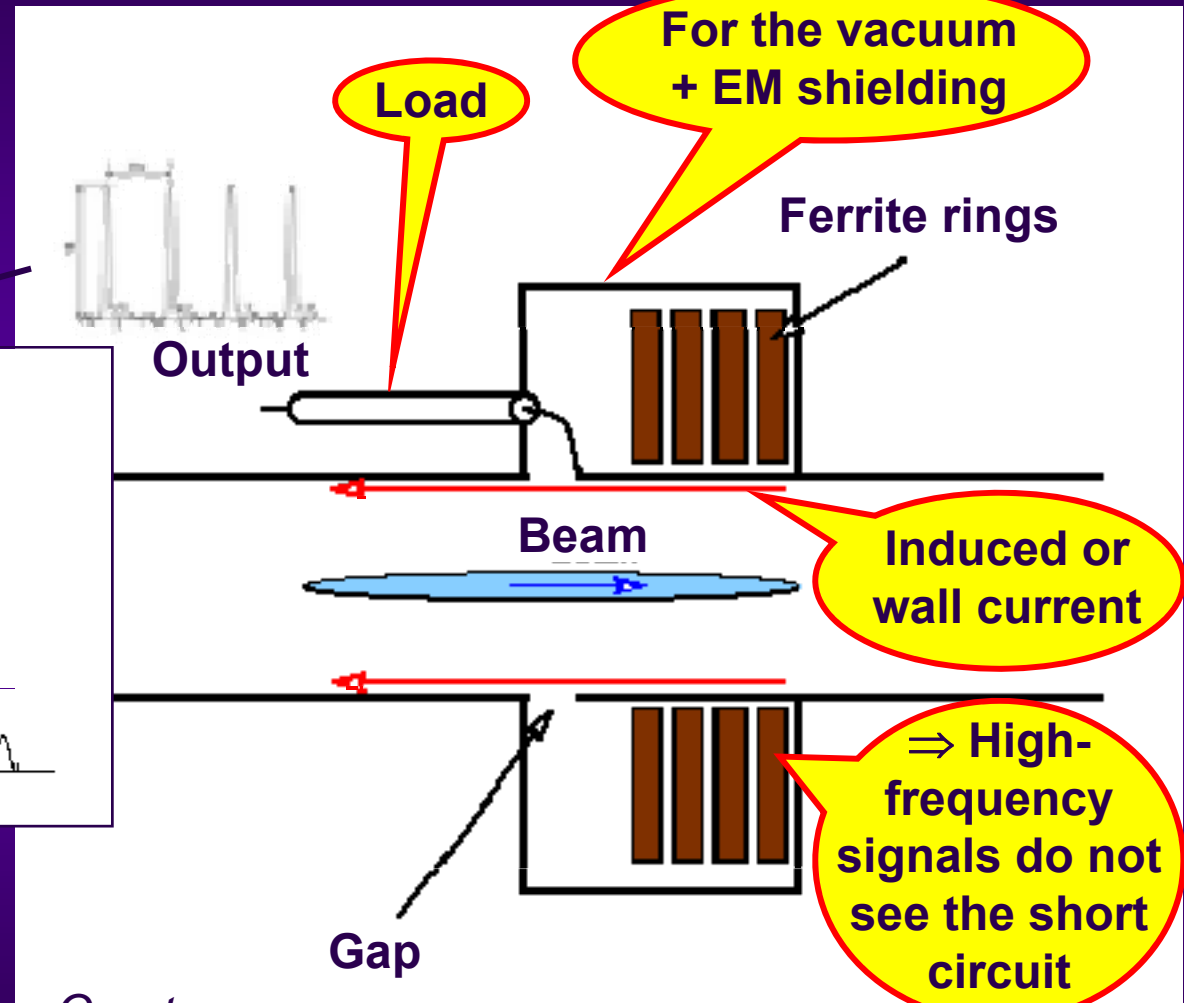

Courtesy  
J. Belleman

**A Wall Current Monitor**

## BEAM CONTROL (3/8)



**WALL CURRENT MONITOR  
IN SS3 OF THE PS**

# BEAM CONTROL (4/8)

## ◆ (Transverse) beam POSITION PICK-UP MONITOR

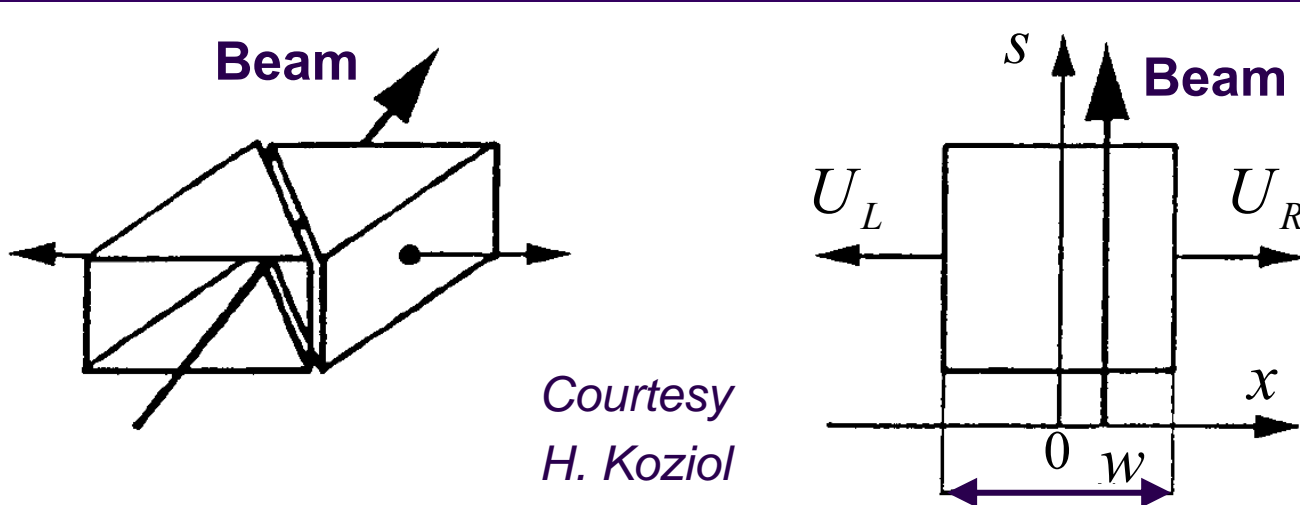

Courtesy  
H. Koziol

$$x = \frac{w}{2} \frac{U_R - U_L}{U_R + U_L}$$

⇒ Horizontal beam orbit measurement in the PS

6 spikes  
observed as  
 $Q_x \approx 6.25$

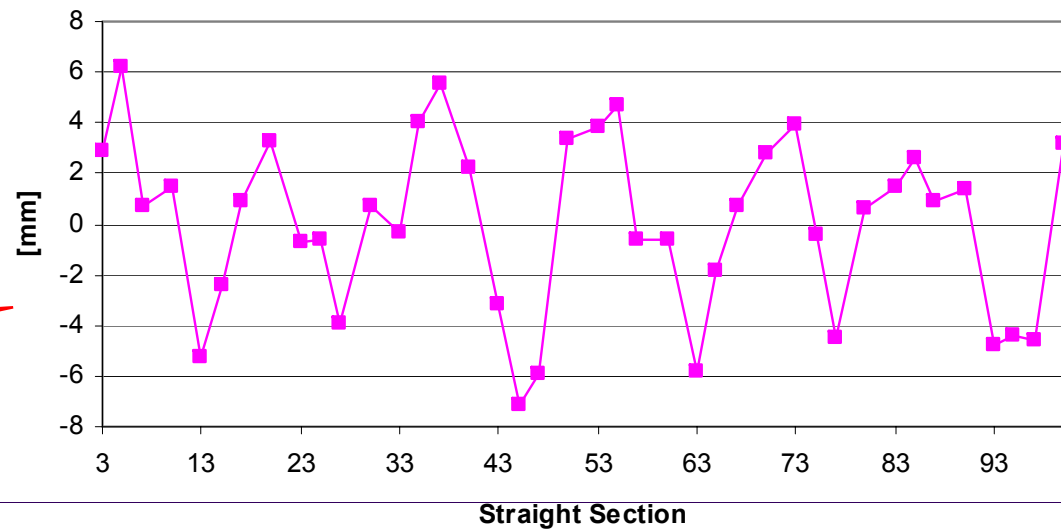



## BEAM CONTROL (5/8)

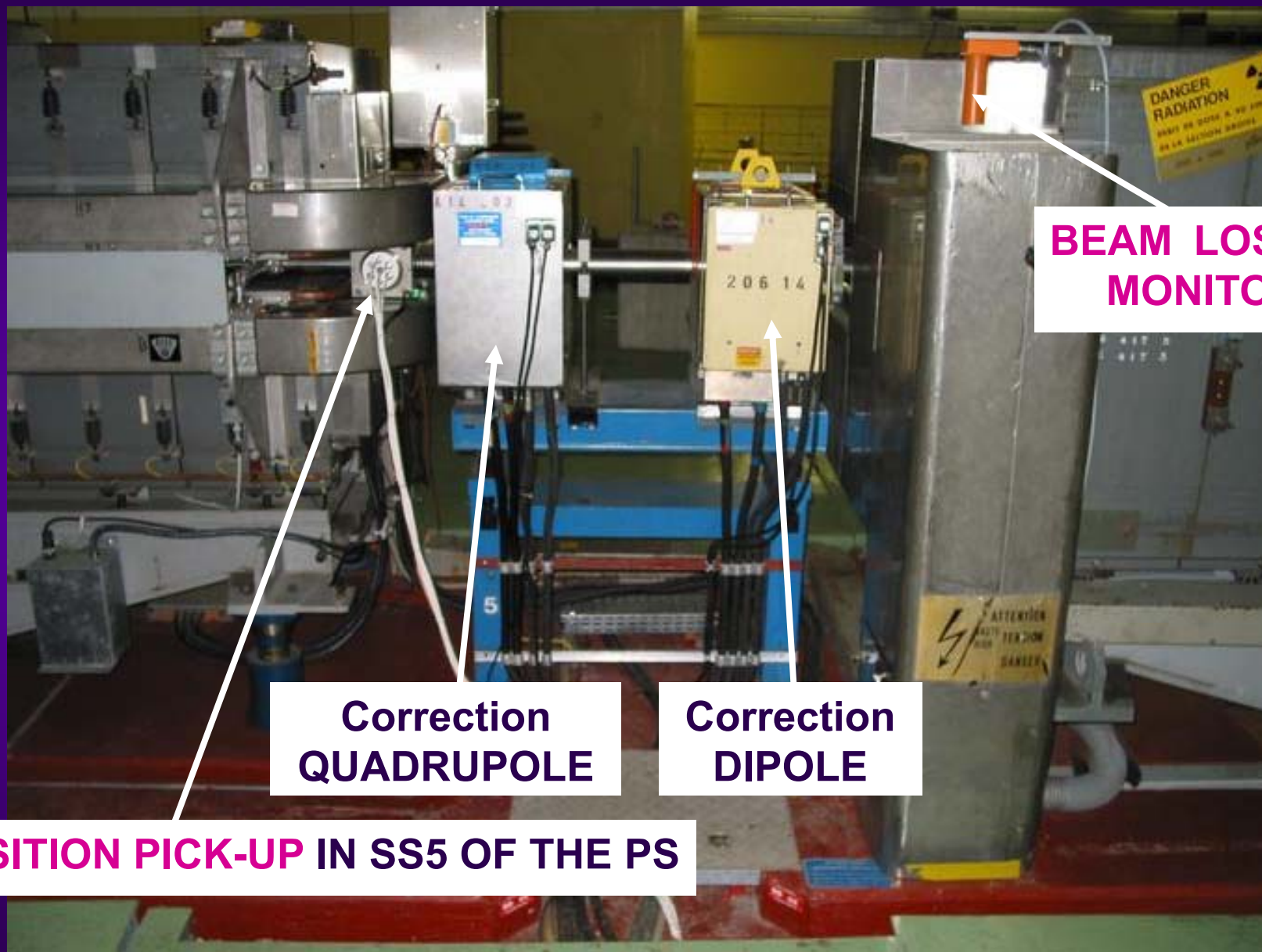

**BEAM LOSS  
MONITOR**

**Correction  
QUADRUPOLE**

**Correction  
DIPOLE**

**POSITION PICK-UP IN SS5 OF THE PS**

# BEAM CONTROL (6/8)

## ◆ FAST WIRE SCANNER

⇒ Measures the transverse beam profiles by detecting the particles scattered from a thin wire swept rapidly through the beam



HORIZONTAL PROFILE

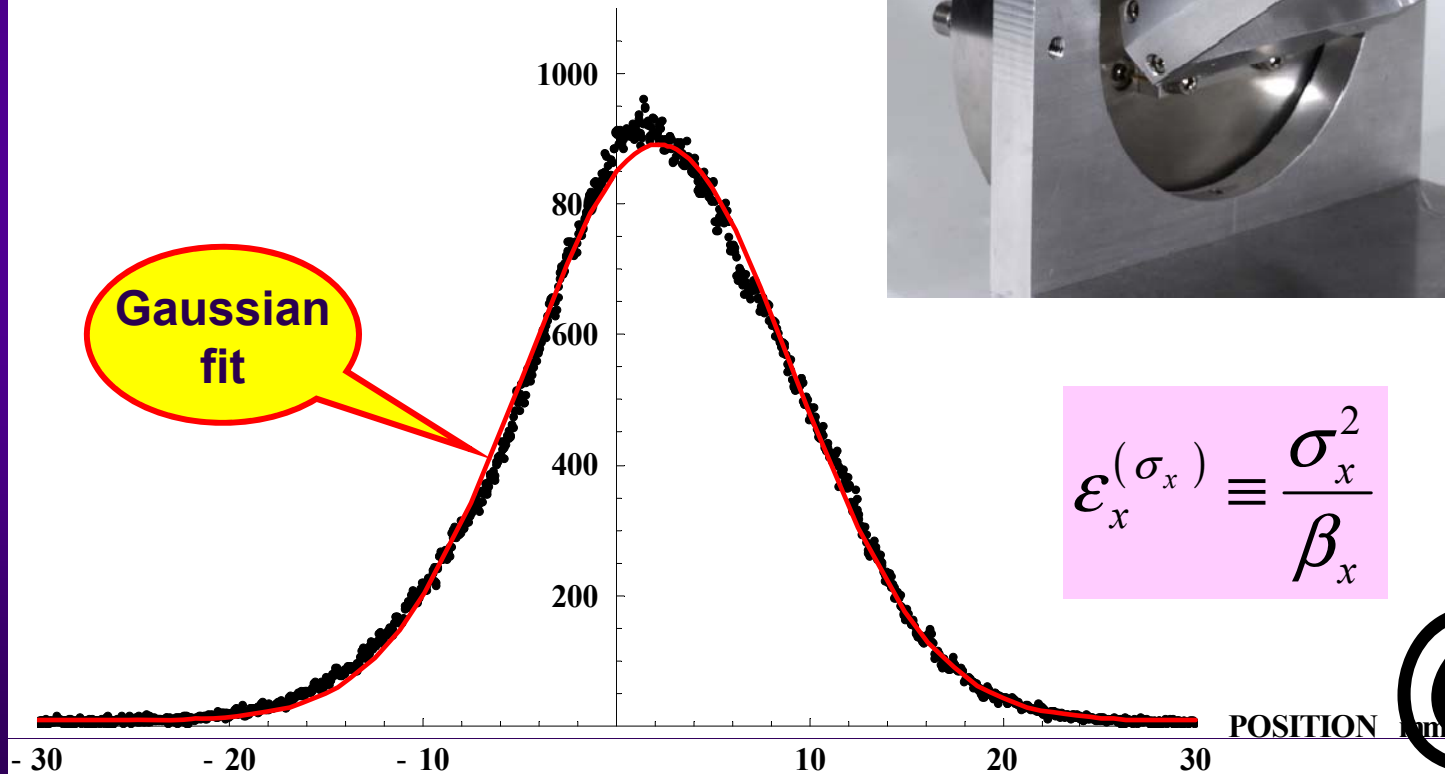



## BEAM CONTROL (7/8)

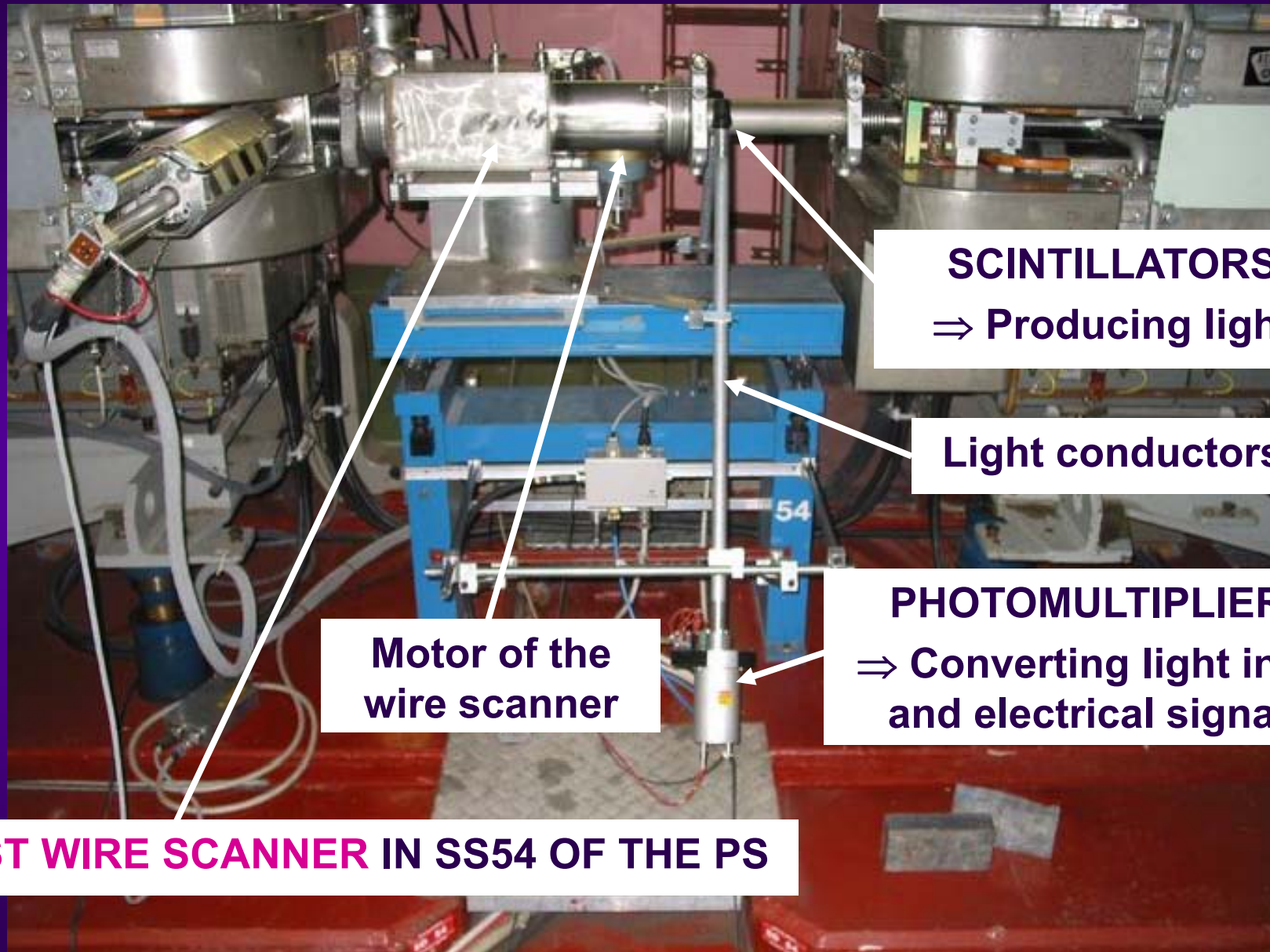

**SCINTILLATORS**  
⇒ Producing light

**Light conductors**

**Motor of the  
wire scanner**

**PHOTOMULTIPLIER**  
⇒ Converting light into  
and electrical signal

**FAST WIRE SCANNER IN SS54 OF THE PS**

# BEAM CONTROL (8/8)

## ◆ BEAM LOSS MONITOR

PS record  
intensity (CNGS  
beam)

$3.42 \cdot 10^{13}$  ppp @ 14 GeV/c  
(Monday 27/09/04 12:47)

Saturation at 255  
⇒ Could be much  
higher

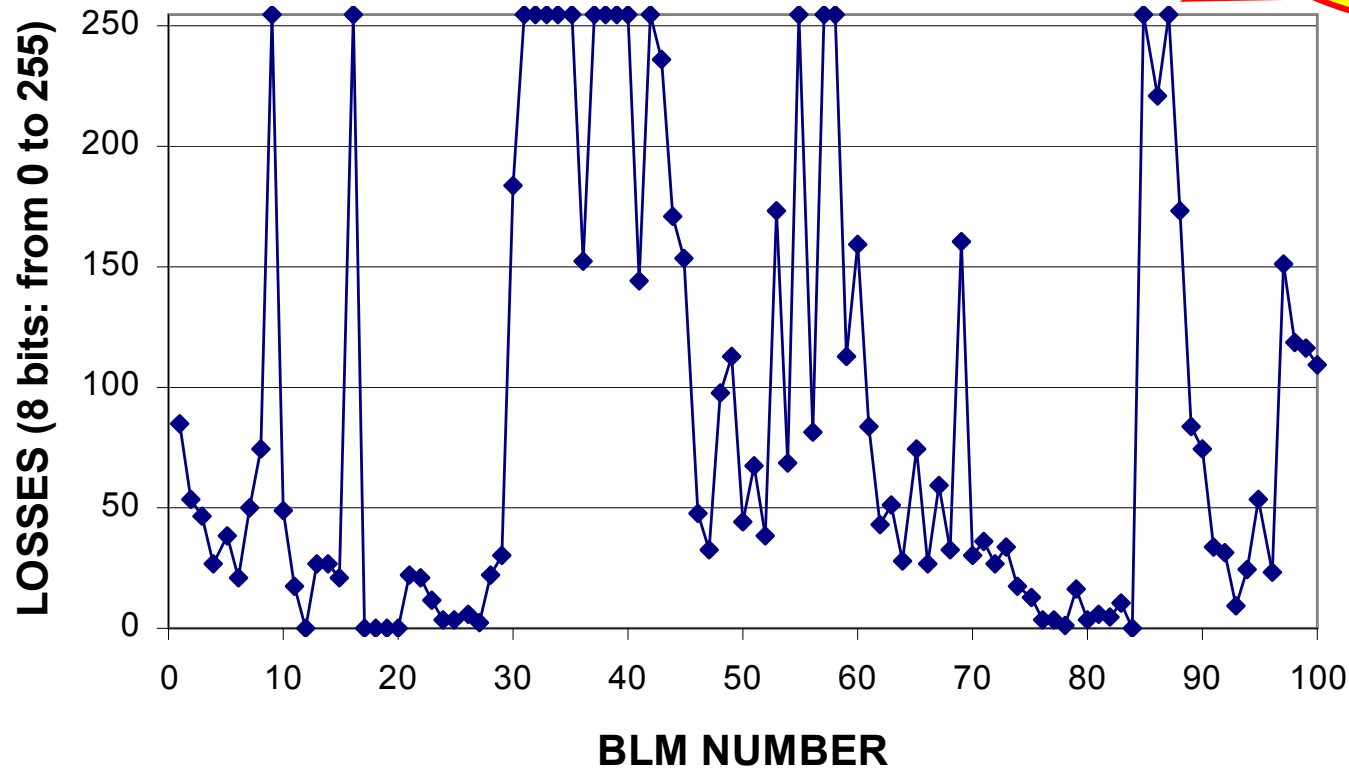

Detector = ACEM  
(Aluminum  
Cathod Electron  
Multiplier), placed  
at the beginning  
of the SS  
⇒ Similar to a  
Photomultiplier  
and it is cheap,  
robust and  
radiation resistant

# LIMITING FACTORS FOR A SYNCHROTRON / COLLIDER

## ⇒ COLLECTIVE EFFECTS (1/34)

### Space charge

2 particles at rest  
or travelling

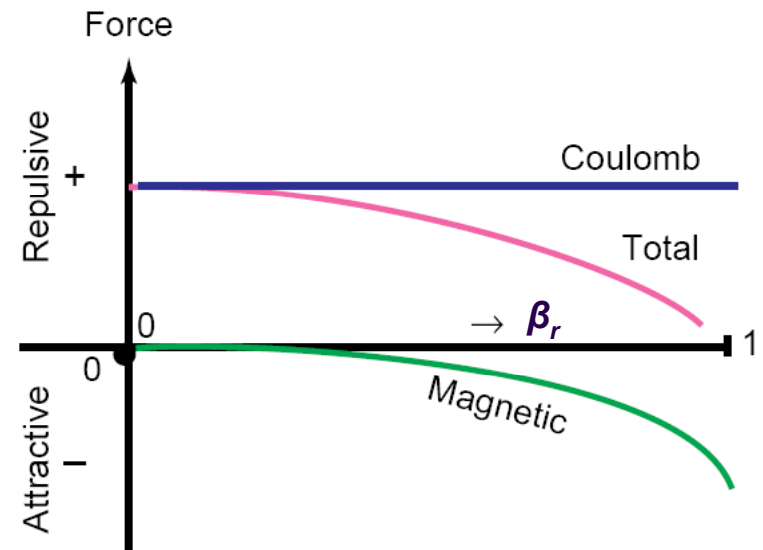
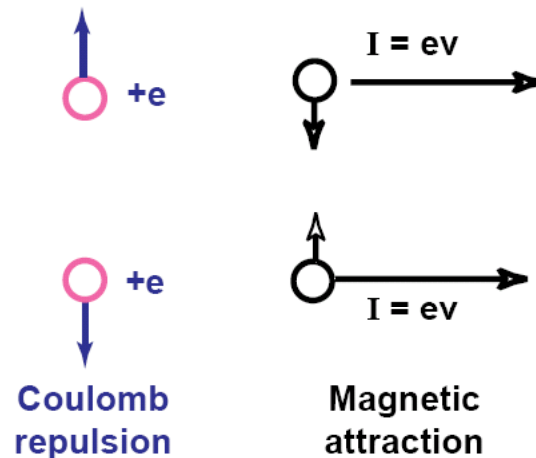

Courtesy  
K. Schindl

Many charged  
particles travelling  
in an unbunched  
beam with circular  
cross-section

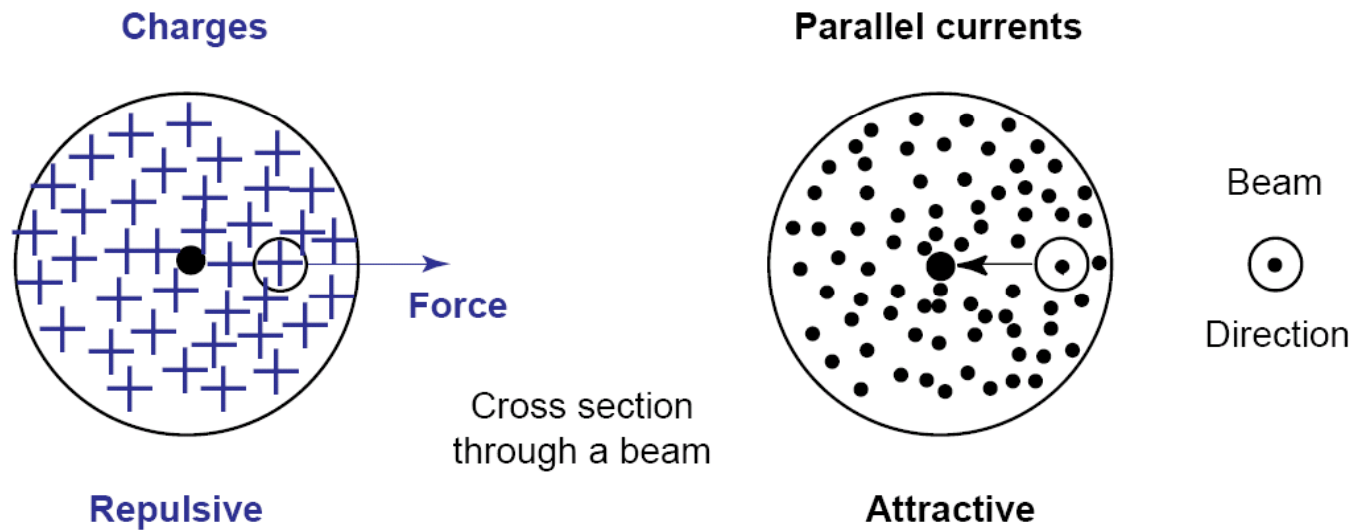

# LIMITING FACTORS FOR A SYNCHROTRON / COLLIDER ⇒ COLLECTIVE EFFECTS (2/34)

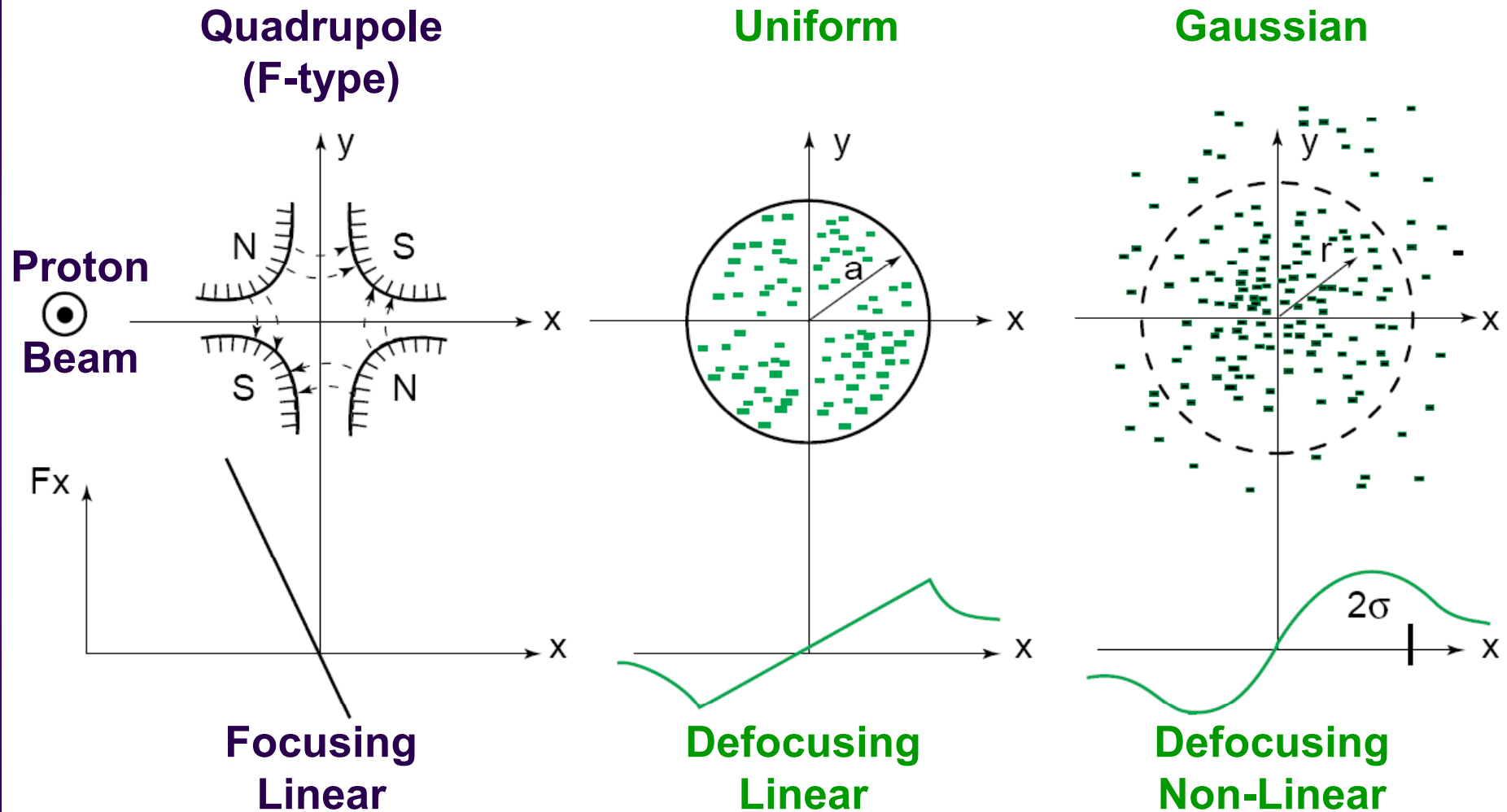

*Courtesy K. Schindl*

# LIMITING FACTORS FOR A SYNCHROTRON / COLLIDER ⇒ COLLECTIVE EFFECTS (3/34)

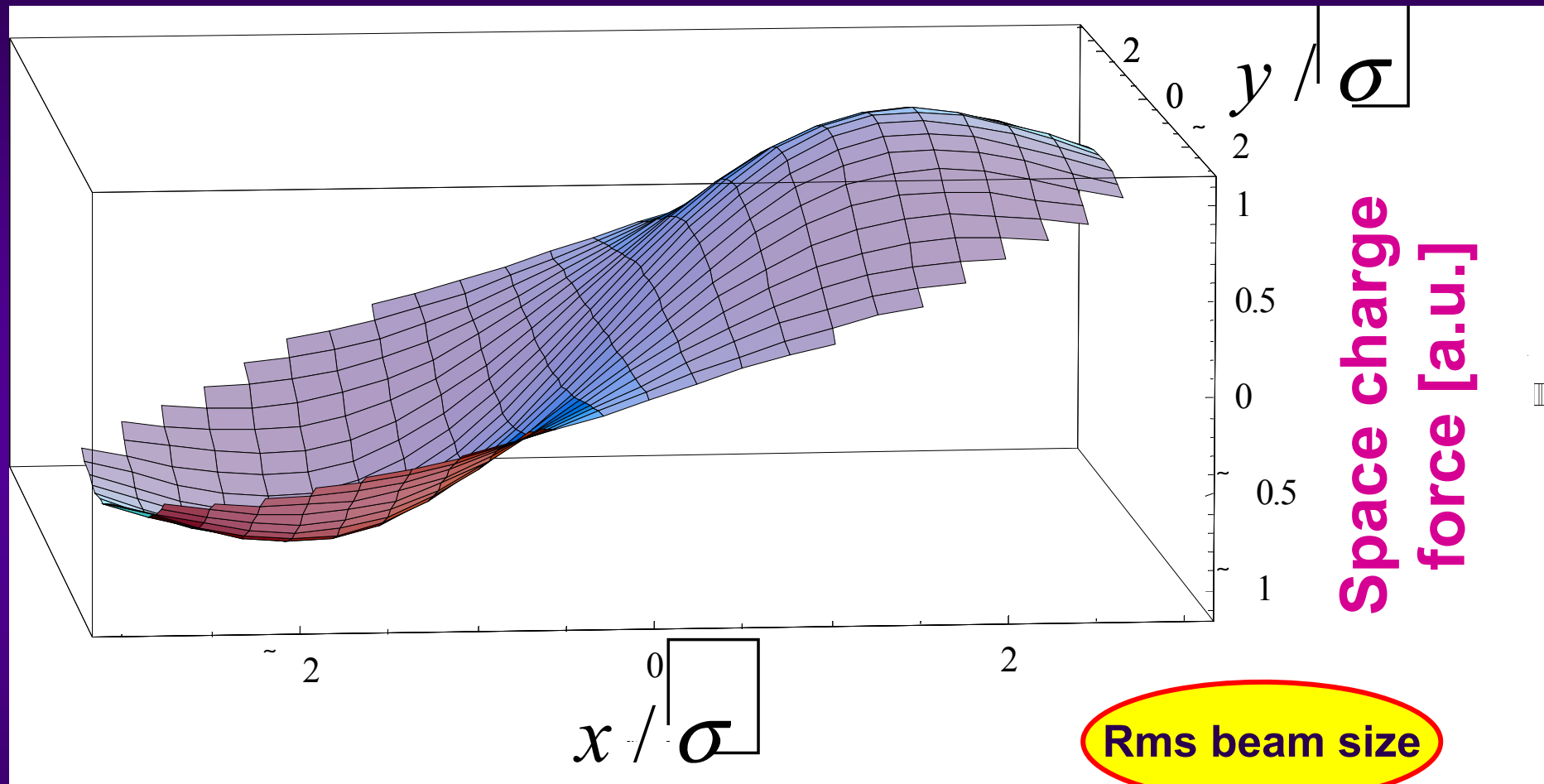

**Case of a bunch with a transverse beam profile extending up to  $3.2 \sigma$**

# LIMITING FACTORS FOR A SYNCHROTRON / COLLIDER

## ⇒ COLLECTIVE EFFECTS (4/34)

### ◆ 2D TUNE FOOTPRINT

⇒ INCOHERENT  
(single-particle) tunes

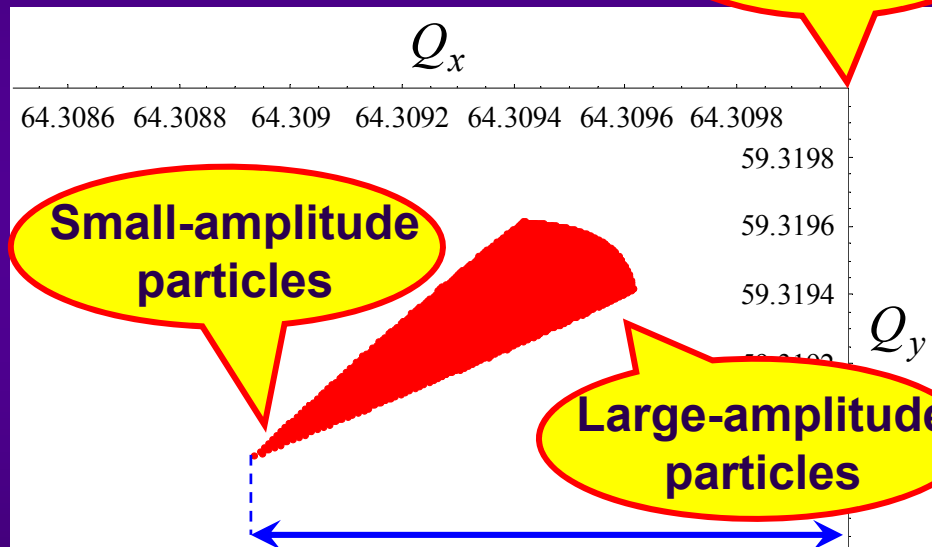

$$\Delta_0 \propto - \frac{N_b}{\beta_r \gamma_r^2 \epsilon_{rms}^{norm}}$$

= Linear space - charge tune shift

### ◆ 3D view of the 2D tune footprint

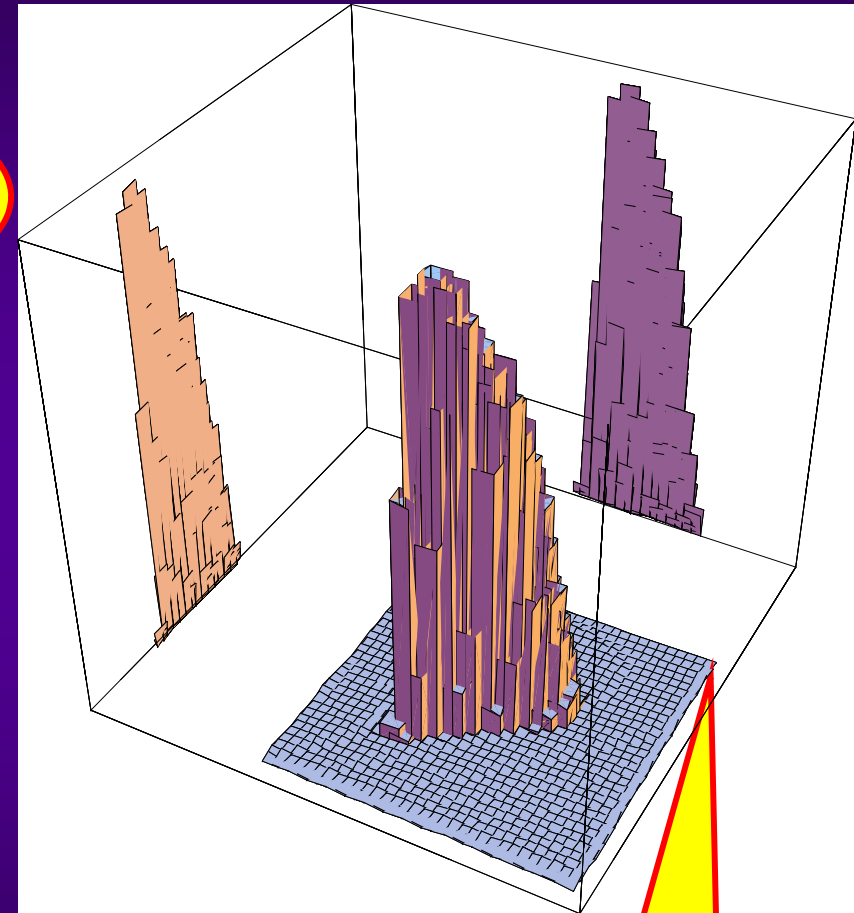

Low-intensity  
working point



# LIMITING FACTORS FOR A SYNCHROTRON / COLLIDER ⇒ COLLECTIVE EFFECTS (5/34)

◆ 2D tune footprint

Low-intensity  
working point

◆ 3D tune footprint

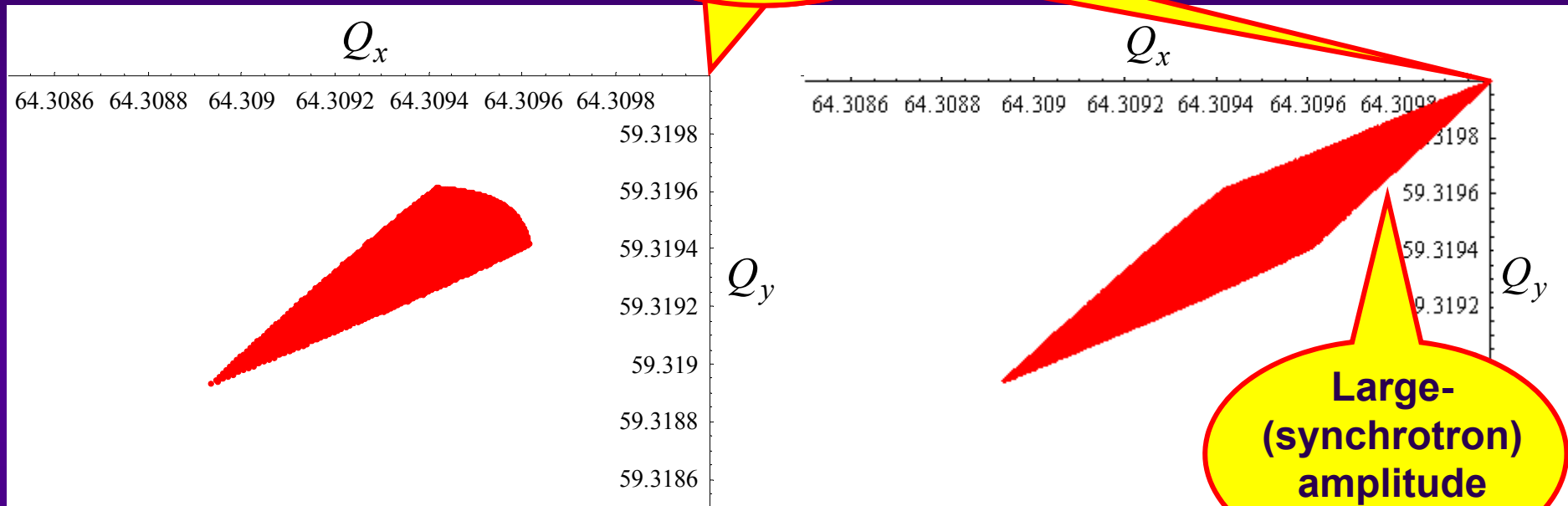

⇒ **The longitudinal variation (due to synchrotron oscillations) of the transverse space-charge force fills the gap until the low-intensity working point**

# LIMITING FACTORS FOR A SYNCHROTRON / COLLIDER ⇒ COLLECTIVE EFFECTS (6/34)

## Interaction with a resonance

$Q_y$

Regime of loss-free core-emittance blow-up

2D Gaussian bunch

$$4 Q_x = 25$$

$Q_x$

$Q_y$

Regime where continuous loss occurs ⇒ Due to longitudinal motion

Particles diffuse into a halo

$Q_x$



# LIMITING FACTORS FOR A SYNCHROTRON / COLLIDER ⇒ COLLECTIVE EFFECTS (7/34)

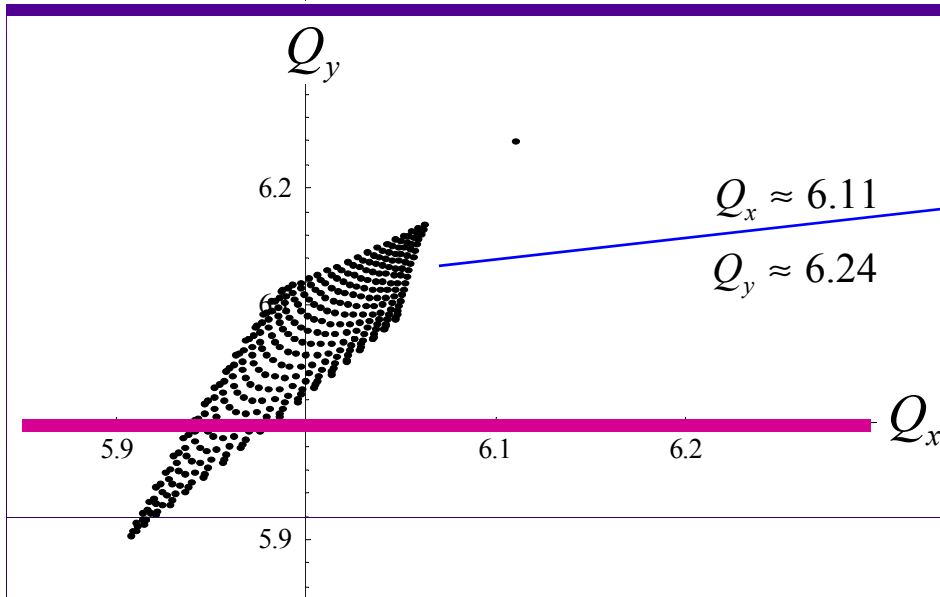
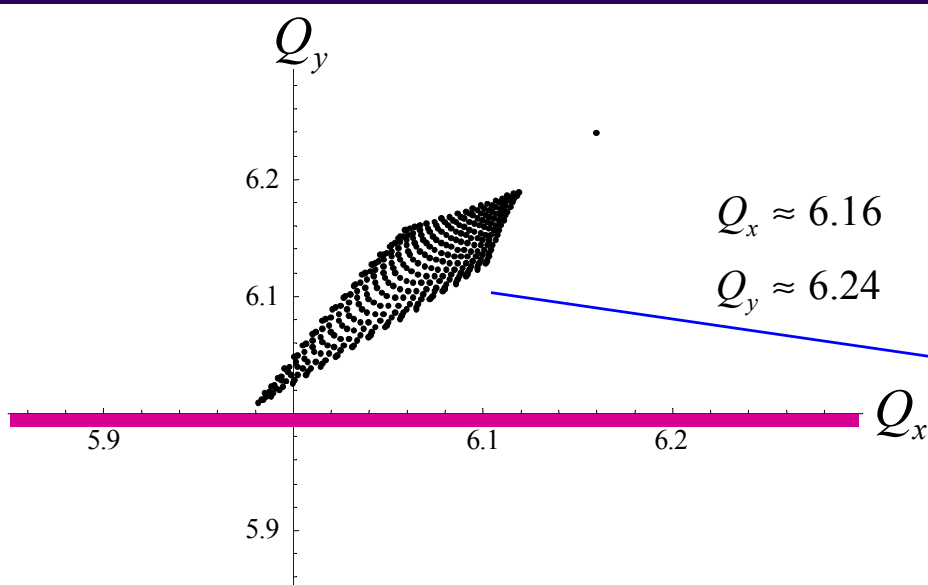

**Horizontal bunch profile  
+ Gaussian fit**

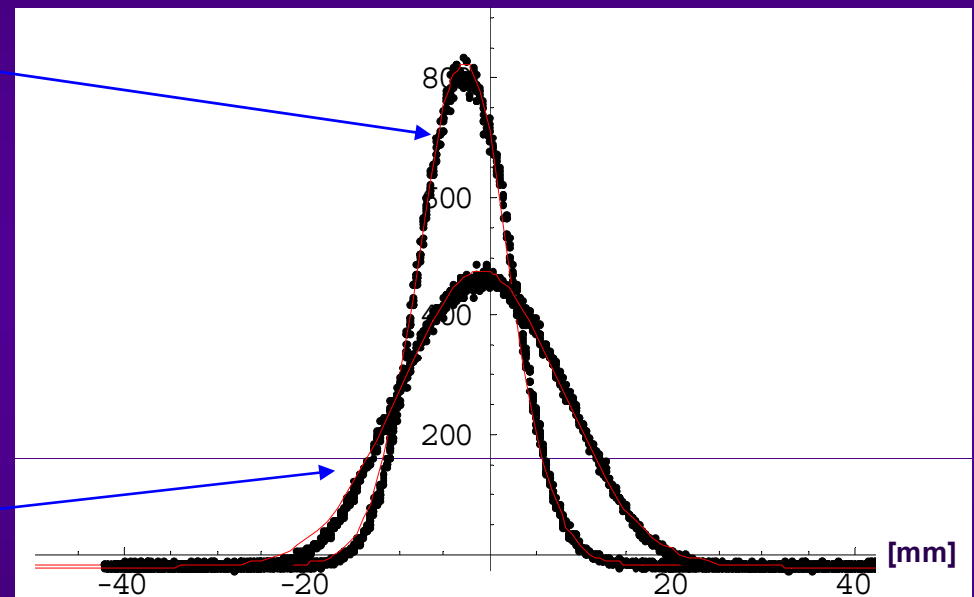

**Regime of loss-free  
core-emittance blow-up**

# LIMITING FACTORS FOR A SYNCHROTRON / COLLIDER ⇒ COLLECTIVE EFFECTS (8/34)

“High-intensity” bunch ⇒ **Bucket separatrix** with/without space charge below transition

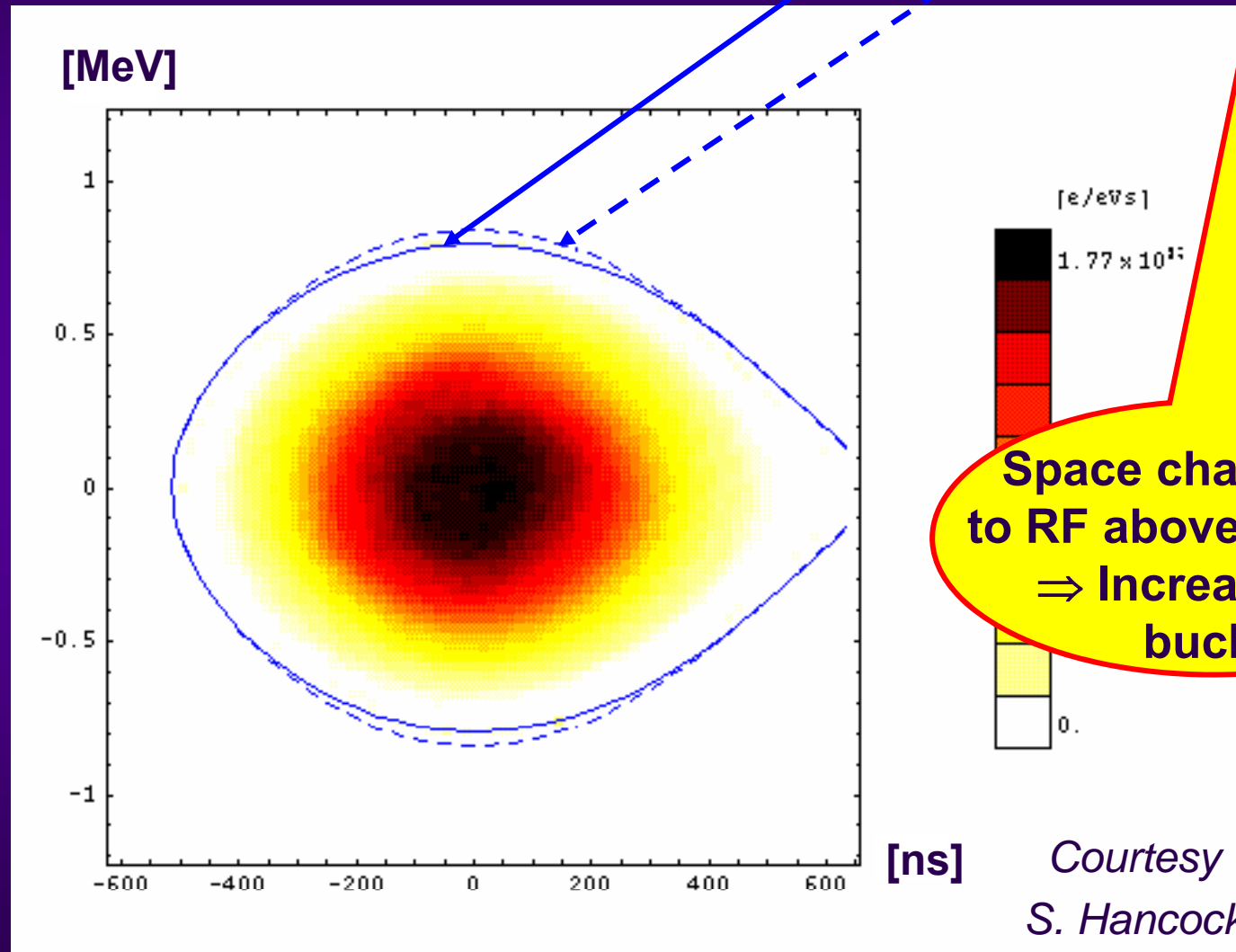

# LIMITING FACTORS FOR A SYNCHROTRON / COLLIDER ⇒ COLLECTIVE EFFECTS (9/34)

## Wake field and impedance

- ◆ Wake fields = **Electromagnetic fields generated by the beam interacting with its surroundings (vacuum pipe, etc.)**
  - Energy loss
  - Beam instabilities
  - Excessive heating
- ◆ **For a collective instability to occur, the** beam environment must not be a perfectly conducting smooth pipe
- ◆ Impedance (**Sessler&Vaccaro**) = Fourier transform of the wake field
- ◆ **As the conductivity, permittivity and permeability of a material depend in general on frequency, it is usually better (or easier) to treat the problem in the frequency domain**

# LIMITING FACTORS FOR A SYNCHROTRON / COLLIDER ⇒ COLLECTIVE EFFECTS (10/34)

- ◆ **Case of the transverse Resistive Wall (usually made of stainless steel or copper) wake field with  $\gamma_r \rightarrow \infty$  (i.e. no space charge effects) and in the “classical thick-wall regime”**

$$W_t^{RW} \propto F_t^{RW} \propto \frac{\sqrt{\rho}}{b^3 \sqrt{|z|}}$$

Resistivity:  
 $\rho_{SS} = 10^{-6} \Omega\text{m}$  and  
 $\rho_{Cu} = 1.5 \times 10^{-8} \Omega\text{m}$   
at room  
temperature

Distance behind  
the bunch

Beam pipe radius  
⇒ Usually few cm  
( $< 2$  mm for some  
LHC collimators!)

# LIMITING FACTORS FOR A SYNCHROTRON / COLLIDER ⇒ COLLECTIVE EFFECTS (11/34)

## BUNCHED-BEAM COHERENT INSTABILITIES COUPLED-BUNCH MODES

Bunch treated as a Macro-Particle

$M = 8$  bunches ⇒  
 8 modes  $n$  (0 to 7)  
 possible

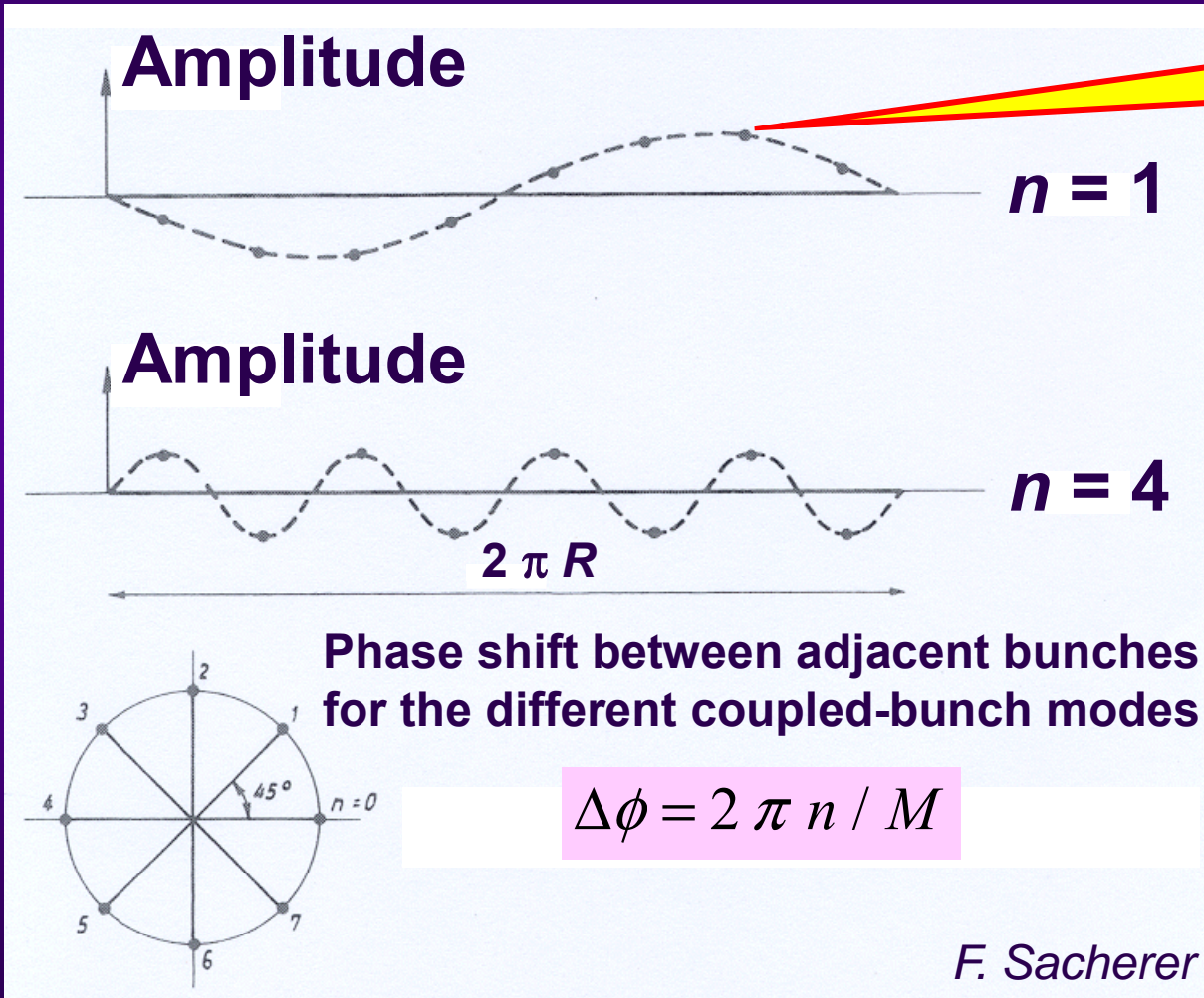

# LIMITING FACTORS FOR A SYNCHROTRON / COLLIDER ⇒ COLLECTIVE EFFECTS (12/34)

Observations with 72 bunches in the SPS in 2006

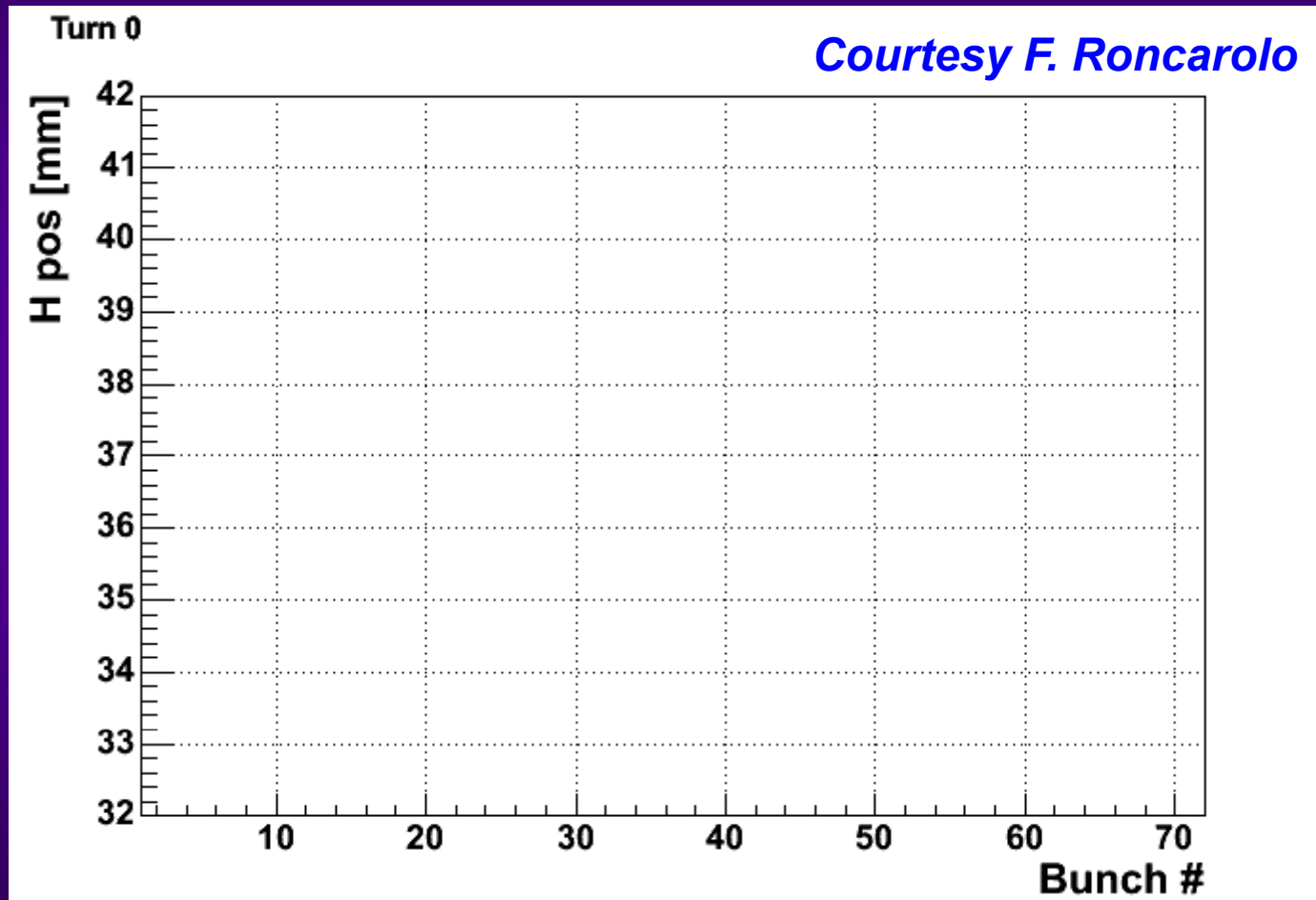

# LIMITING FACTORS FOR A SYNCHROTRON / COLLIDER ⇒ COLLECTIVE EFFECTS (13/34)

## COHERENT frequency (or tune) and INSTABILITY RISE-TIME

- ◆ We are looking for coherent motions proportional to  $e^{j\omega t}$

$$\omega = \omega_R + j \omega_i$$

⇒

$$e^{j\omega t} = e^{j(\omega_R + j \omega_i) t} = e^{j\omega_R t} e^{-\frac{t}{\tau}}$$

$$Q_{y,coh} = \frac{\omega_R}{\omega_{rev}}$$

Coherent (angular) frequency

Coherent tune

where  $\tau$  is the instability rise time [in s]:

$$\tau = -\frac{1}{\omega_i}$$

# LIMITING FACTORS FOR A SYNCHROTRON / COLLIDER ⇒ COLLECTIVE EFFECTS (14/34)

## HEAD-TAIL (Single-bunch) MODES: Low intensity

- ◆ **Defined by 2 modes (as there are 2 degrees of freedom, amplitude and phase) ⇒ Azimuthal mode  $m$  and radial mode  $q$**
- ◆ **The basic mathematical tool used for the mode representation of the beam motion is the VLASOV EQUATION, using a distribution of particles instead of the single-particle formalism**
- ◆ **The Vlasov equation (in its most simple form) is nothing else but a collisionless Boltzmann equation, or an expression for the LIOUVILLE'S CONSERVATION OF PHASE SPACE DENSITY\***

**\*According to the Liouville's theorem, the particles, in a non-dissipative system of forces, move like an incompressible fluid in phase space**



# LIMITING FACTORS FOR A SYNCHROTRON / COLLIDER ⇒ COLLECTIVE EFFECTS (15/34)

Signal at position Pick-Up predicted by Theory  
(several turns superimposed)

Head of  
the bunch

Tail of the  
bunch

Mode  $mq \Rightarrow q$  nodes

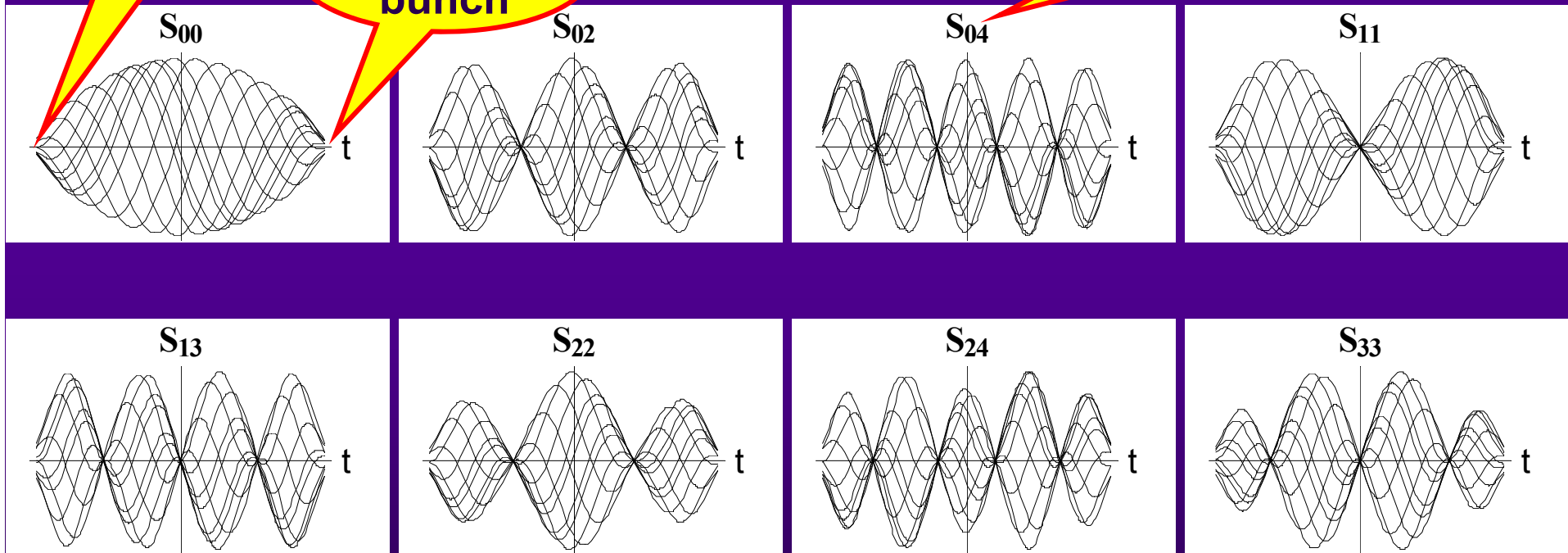

⇒ Standing-wave pattern **along the bunch**

# LIMITING FACTORS FOR A SYNCHROTRON / COLLIDER ⇒ COLLECTIVE EFFECTS (16/34)

Observations **in the PS in 1999 (20 revolutions superimposed)**

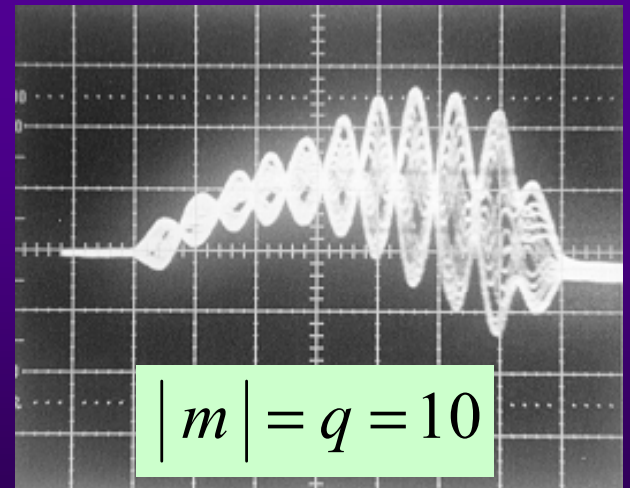
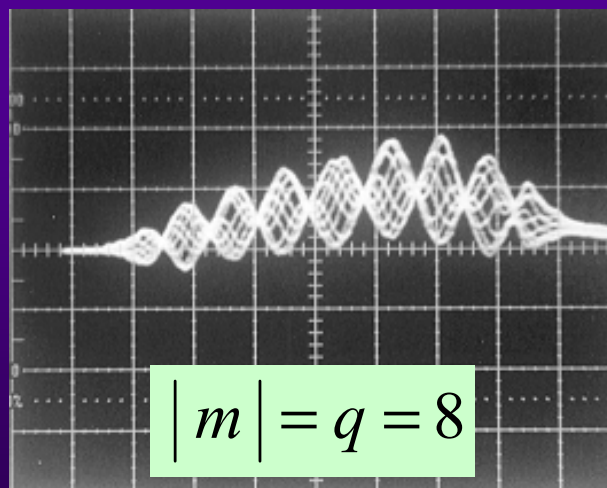
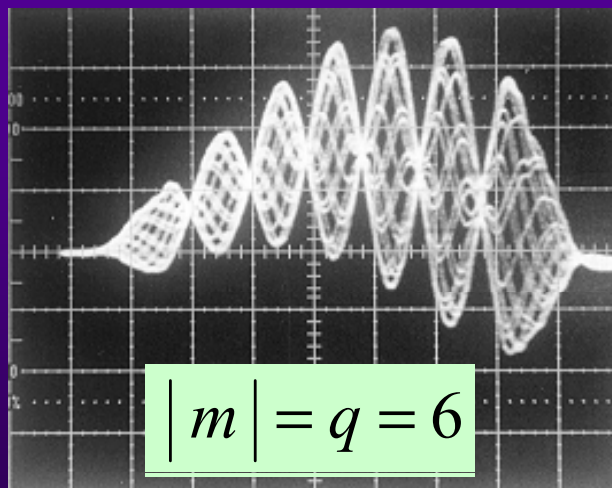
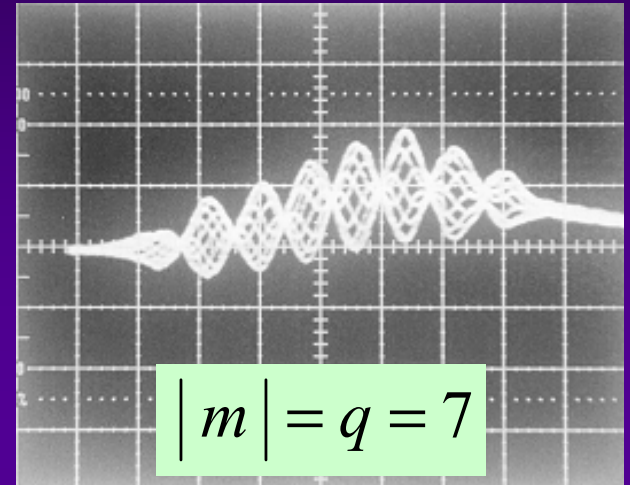
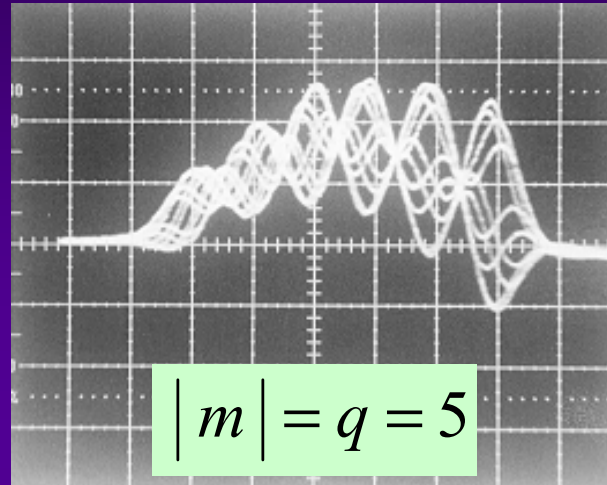
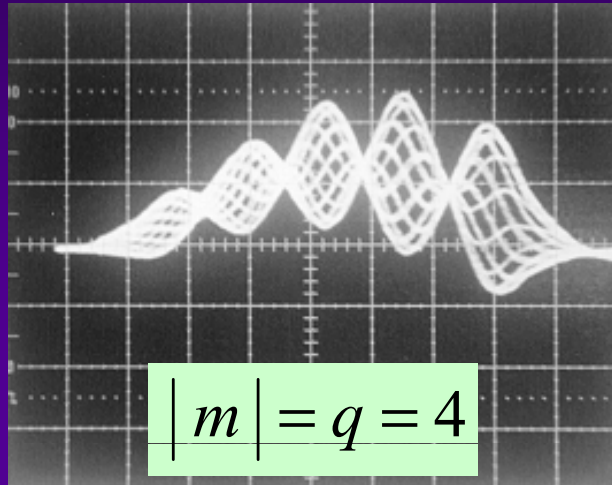

Time (20 ns/div)

# LIMITING FACTORS FOR A SYNCHROTRON / COLLIDER ⇒ COLLECTIVE EFFECTS (17/34)

HEAD-TAIL (Single-bunch) MODES: High intensity  
⇒ Transverse Mode-Coupling instability

$\Sigma$ ,  $\Delta R$ ,  $\Delta V$  signals

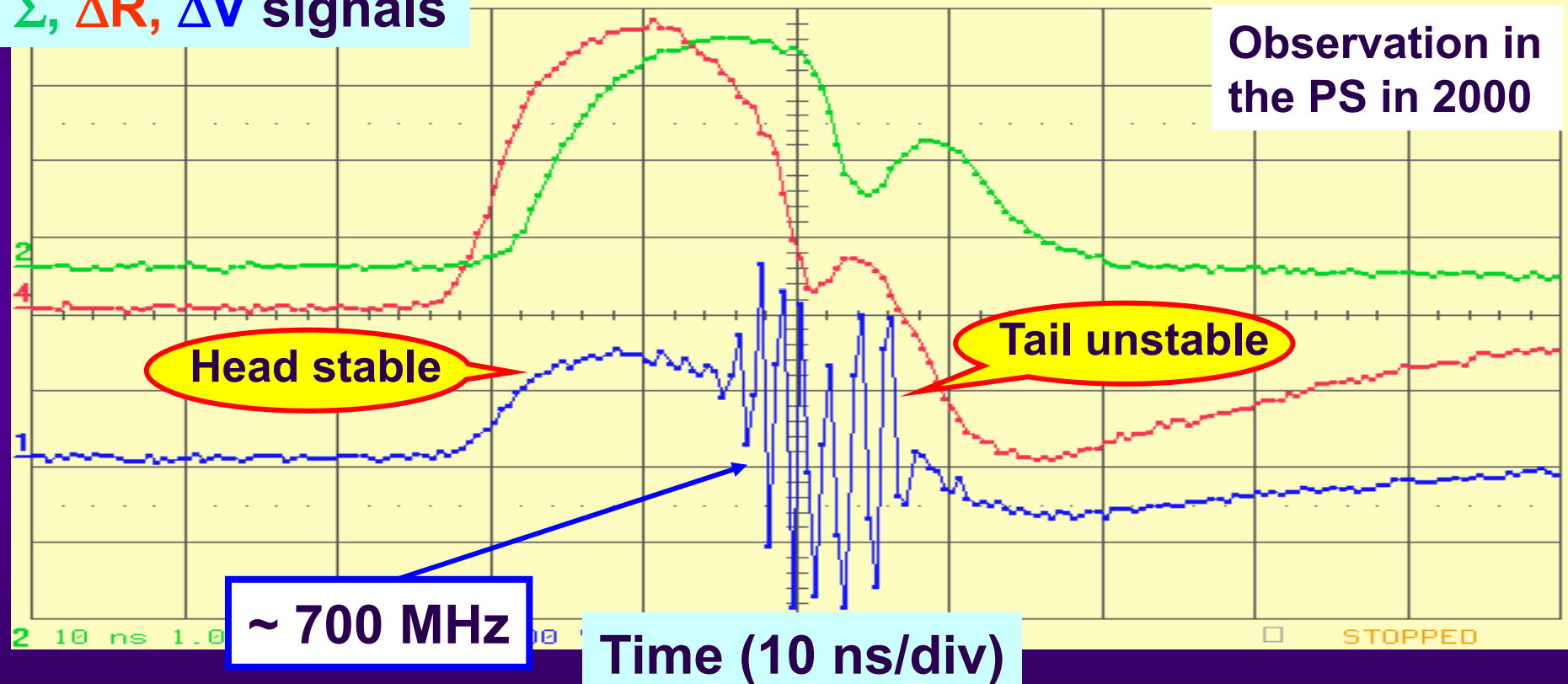

⇒ Travelling-wave pattern along the bunch

# LIMITING FACTORS FOR A SYNCHROTRON / COLLIDER ⇒ COLLECTIVE EFFECTS (18/34)

## Observation in the SPS in 2003

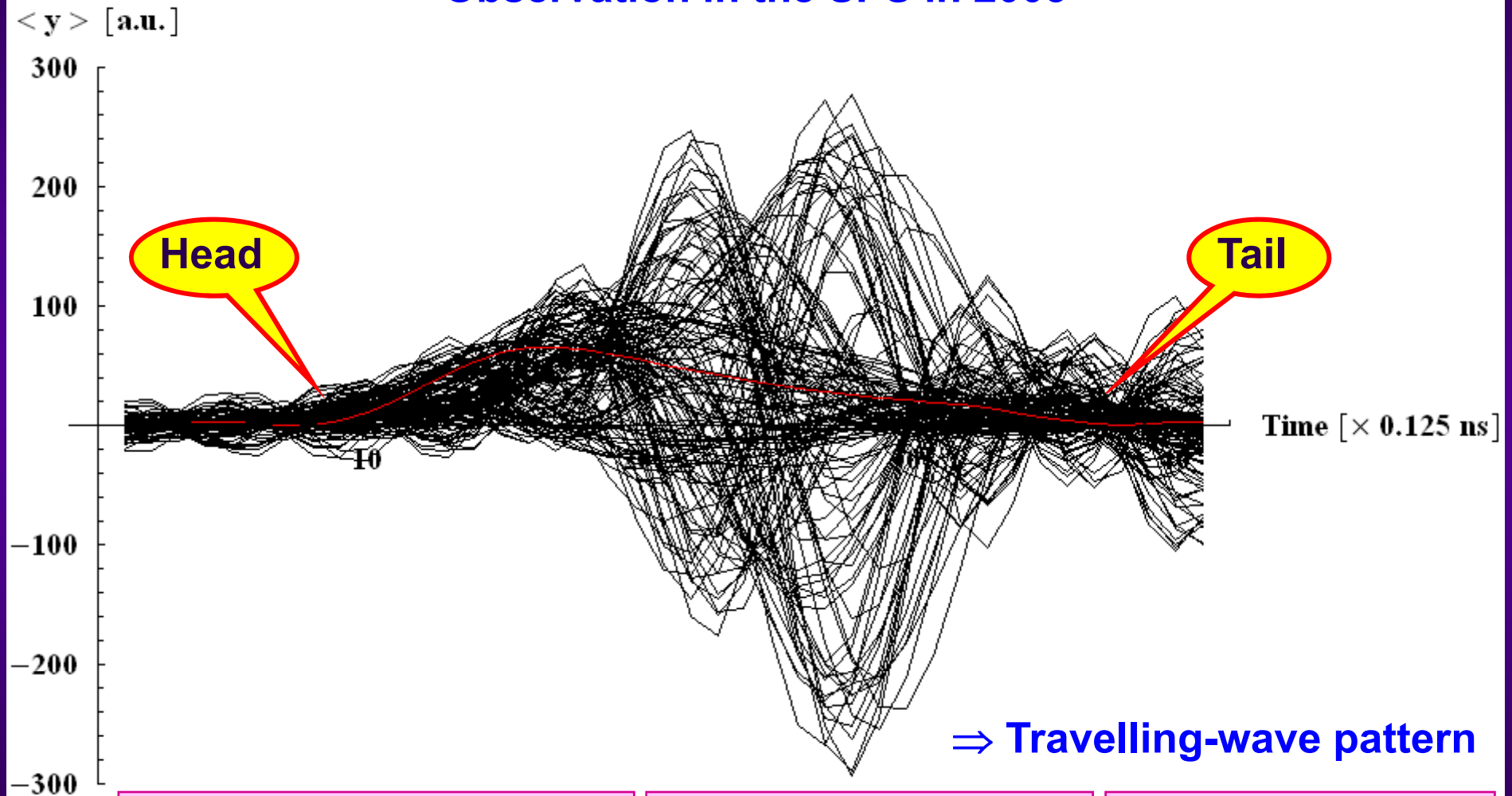

1<sup>st</sup> trace (in red) = turn 2

Last trace = turn 150

Every turn shown

# LIMITING FACTORS FOR A SYNCHROTRON / COLLIDER ⇒ COLLECTIVE EFFECTS (19/34)

Similar phenomena in the longitudinal plane ⇒ Observation of an unstable bunch (sextupolar instability) in the PS Booster in 2000

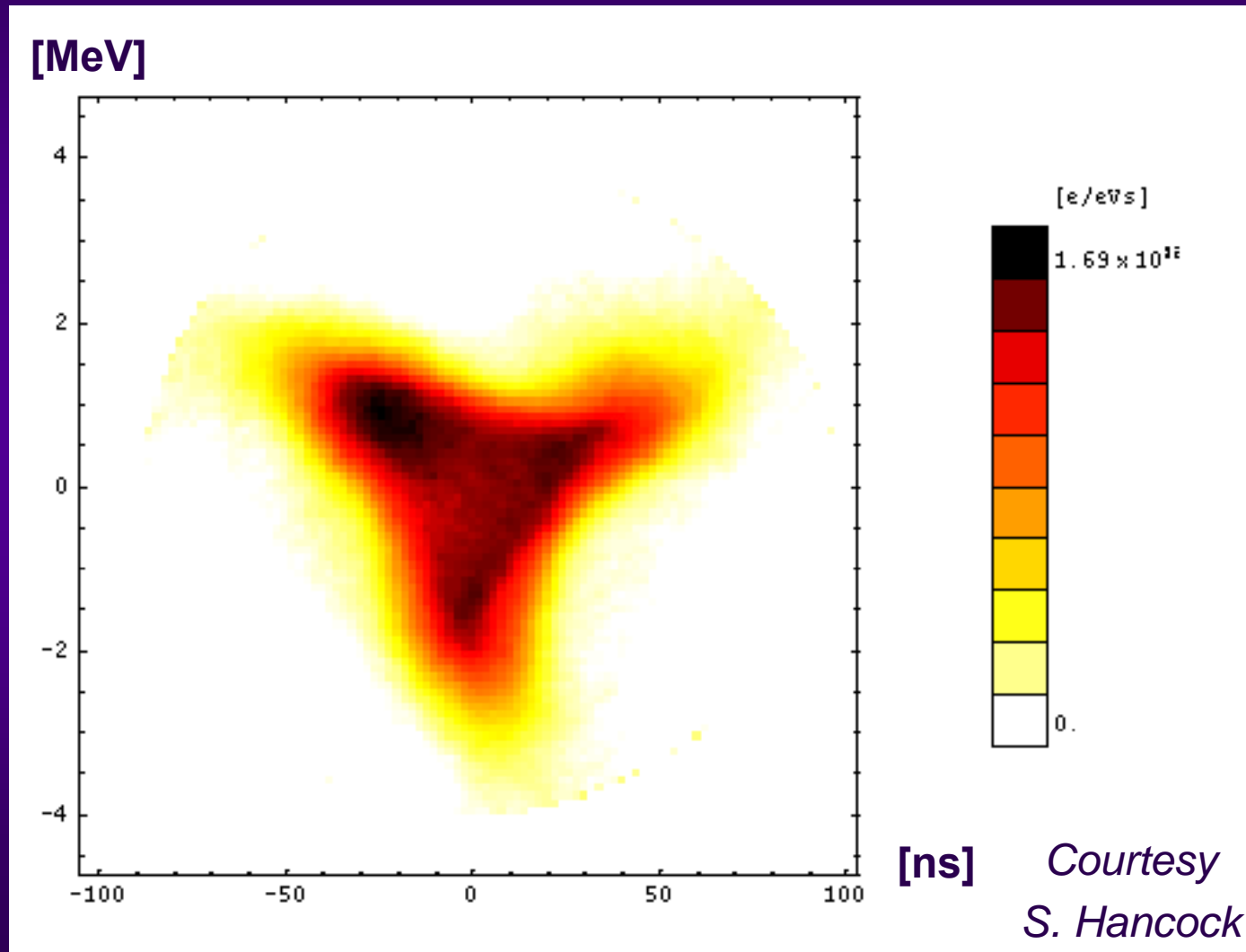

# LIMITING FACTORS FOR A SYNCHROTRON / COLLIDER

## ⇒ COLLECTIVE EFFECTS (20/34)

Courtesy O. Bruning

### ◆ Stabilization methods

Stabilization when the coherent tune is inside the incoherent tune spread (due to octupoles....)

#### Landau Damping

##### ● Three Coupled Oscillators:

■ equal frequencies

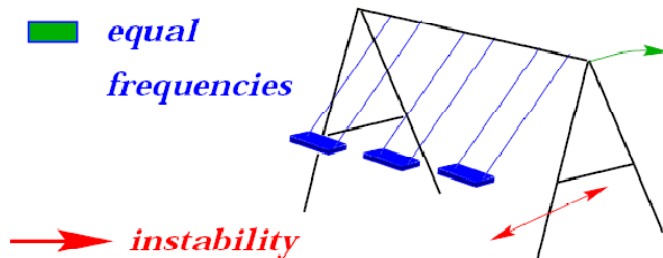

##### ● Three Coupled Oscillators:

■ different frequencies

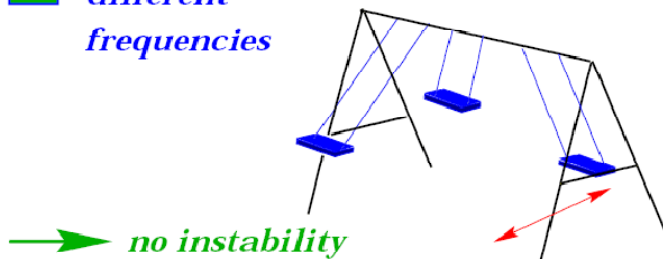

##### ● Limit:

↪ frequency spread (tune spread)  
↪ single particle resonances

#### ■ Landau damping

#### ■ Feedbacks

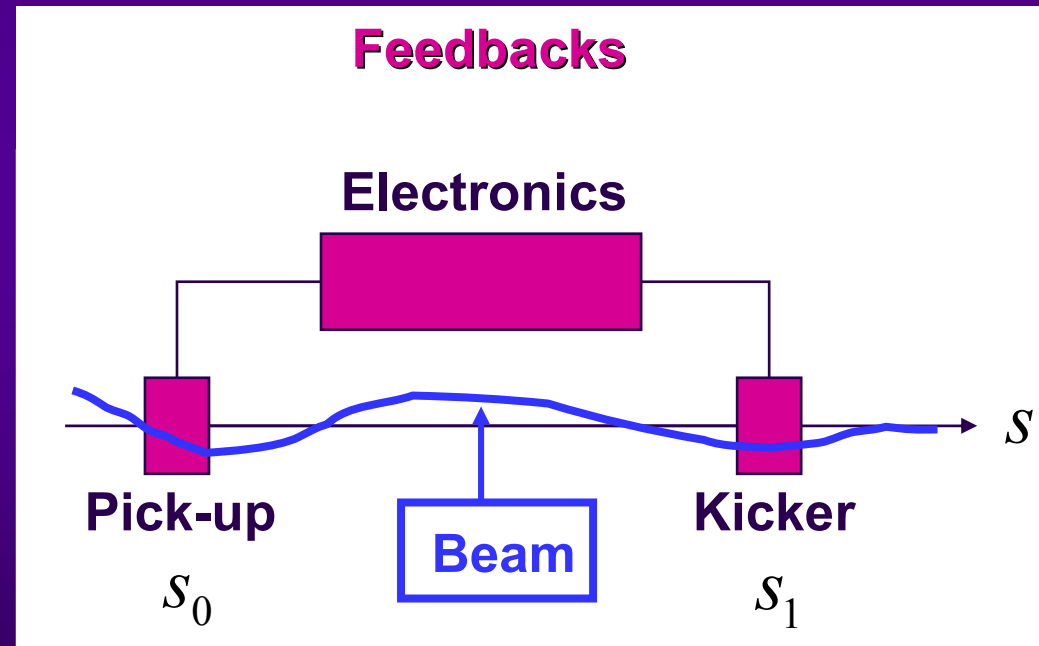

#### ■ Linear coupling between the transverse planes (from skew quadrupoles)



# LIMITING FACTORS FOR A SYNCHROTRON / COLLIDER ⇒ COLLECTIVE EFFECTS (21/34)

## LAYOUT OF THE LHC

Courtesy W. Herr

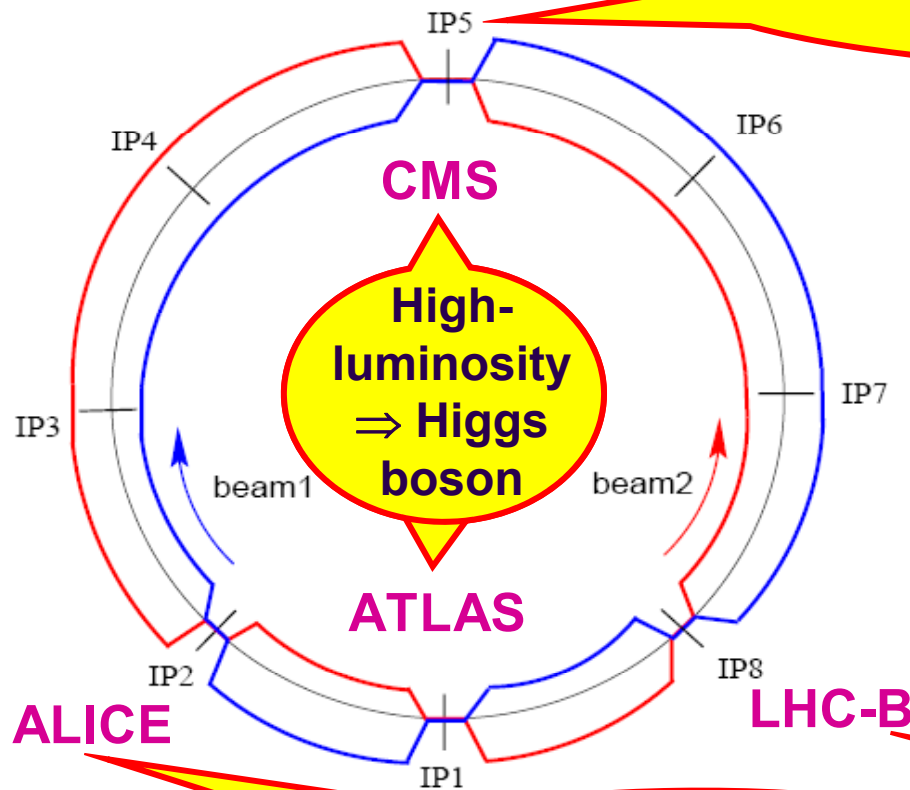

### Beam-beam interaction

#### + TOTEM

⇒ Measure the total proton-proton cross-section and study elastic scattering and diffractive physics

- ◆ Incoherent beam-beam effects  
⇒ Lifetime + dynamic aperture
- ◆ PACMAN effects ⇒ Bunch to bunch variation
- ◆ Coherent beam-beam effects  
⇒ Beam oscillations and instabilities

Ions ⇒ New phase of matter expected: Quark-Gluon Plasma (QGP)

Beauty quark physics

# LIMITING FACTORS FOR A SYNCHROTRON / COLLIDER ⇒ COLLECTIVE EFFECTS (22/34)

**CROSSING ANGLE** ⇒ To avoid unwanted collisions, a crossing angle is needed to separate the 2 beams in the part of the machine where they share a vacuum chamber

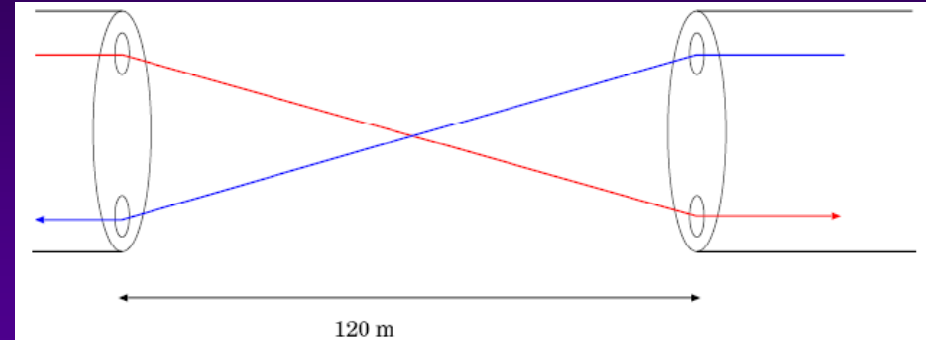

*Courtesy W. Herr*

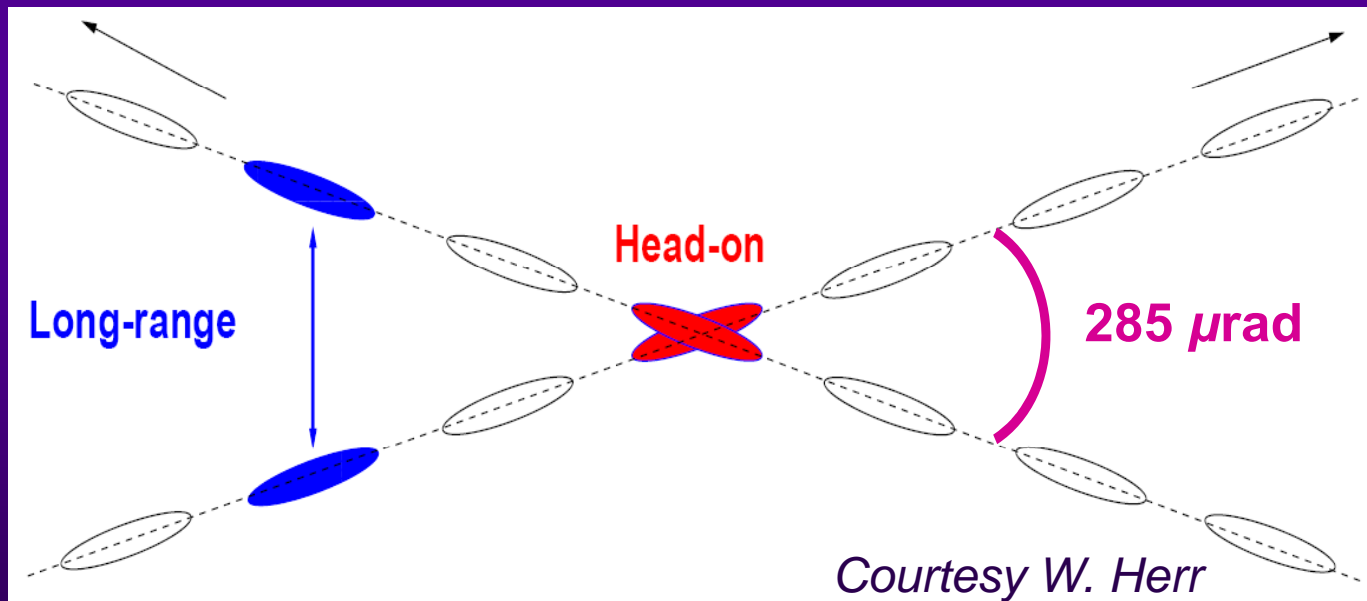

- ◆ 30 long-range interactions around each IP ⇒ 120 in total
- ◆ Separation:  $9\sigma$



**LIMITING FACTORS FOR A SYNCHROTRON / COLLIDER**  
**⇒ COLLECTIVE EFFECTS (23/34)**  
**◆ COLLISION in IP1 (ATLAS)**

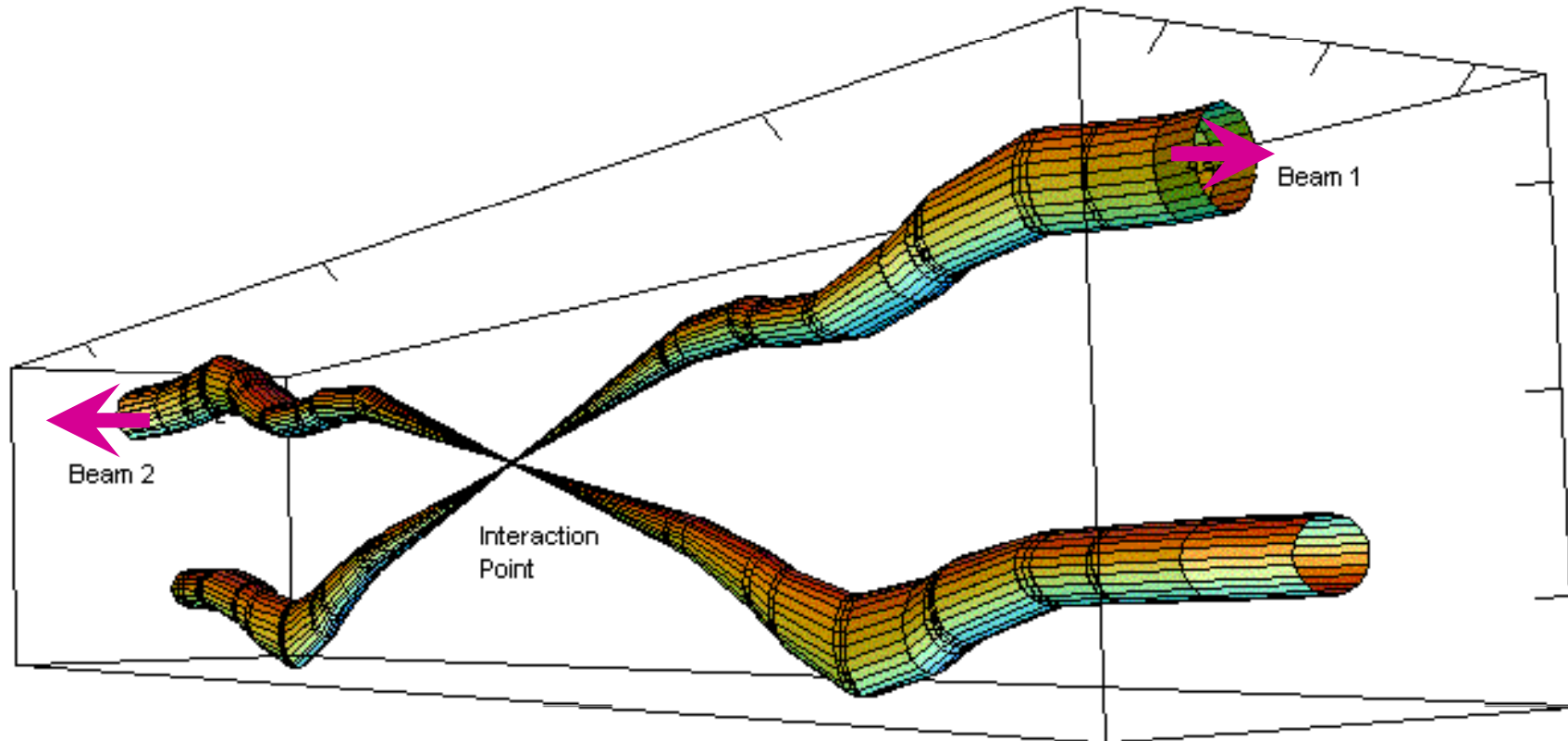

Relative beam sizes around IP1 (Atlas) in collision

**⇒ Vertical crossing angle in IP1 (ATLAS) and horizontal one in IP5 (CMS)**

# LIMITING FACTORS FOR A SYNCHROTRON / COLLIDER ⇒ COLLECTIVE EFFECTS (24/34)

- ◆ 2D tune footprint for nominal LHC parameters in collision. Particles up to amplitudes of  $6\sigma$  are included

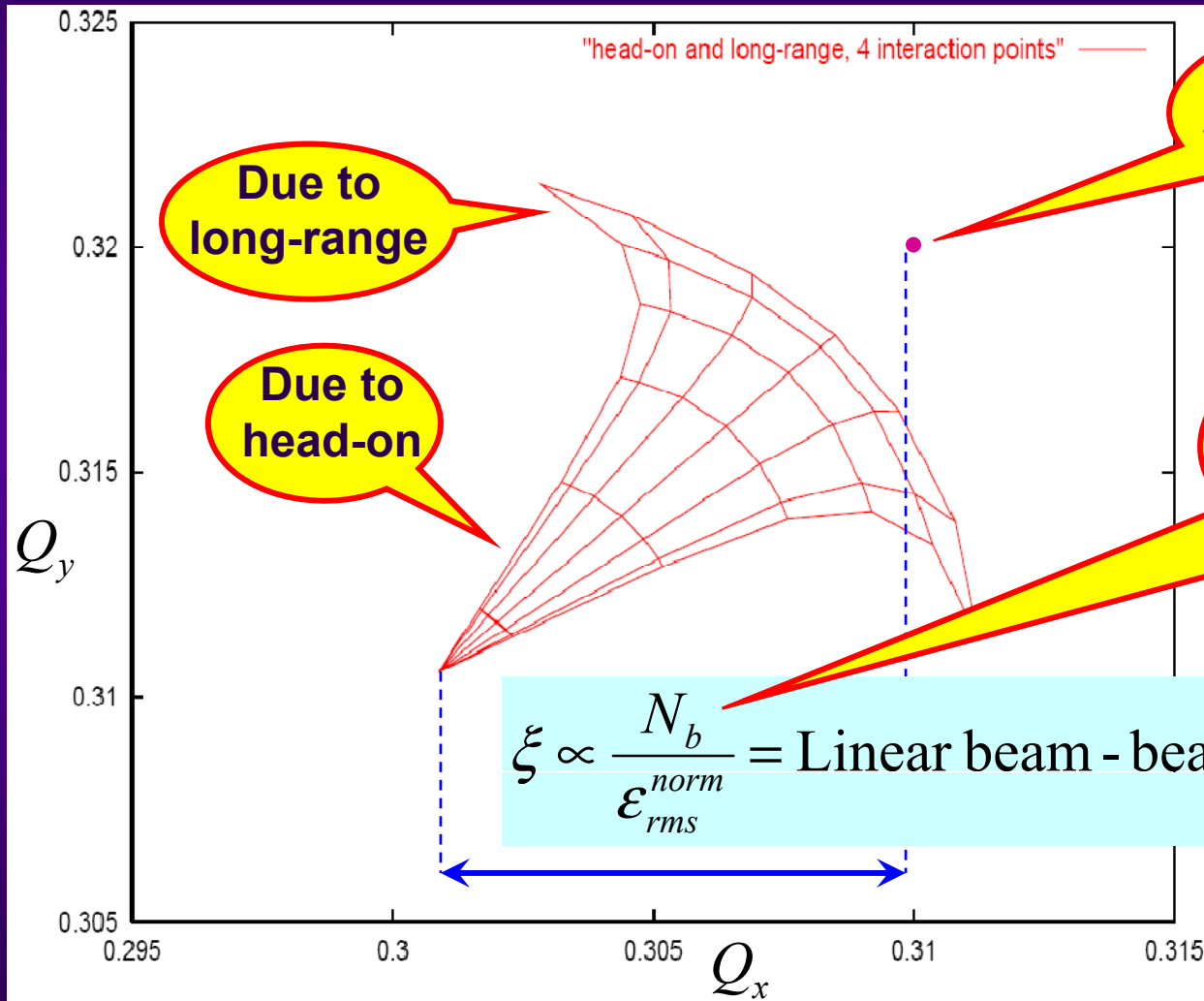

Low-intensity working point

Due to long-range

Due to head-on

No  $1 / \gamma_r^2$  term as for space charge, as the 2 beams are moving in opposite direction

$$\xi \propto \frac{N_b}{\epsilon_{rms}^{norm}} = \text{Linear beam-beam tune shift}$$

Courtesy W. Herr

# LIMITING FACTORS FOR A SYNCHROTRON / COLLIDER ⇒ COLLECTIVE EFFECTS (25/34)

## ◆ PACMAN BUNCHES

- **LHC bunch filling not continuous: Holes for injection, extraction, dump...**
- **2808 bunches out of 3564 possible bunches ⇒ 1756 holes**
- **Holes will meet holes at the IPs**
- **But not always... a bunch can meet a hole at the beginning and end of a bunch train**

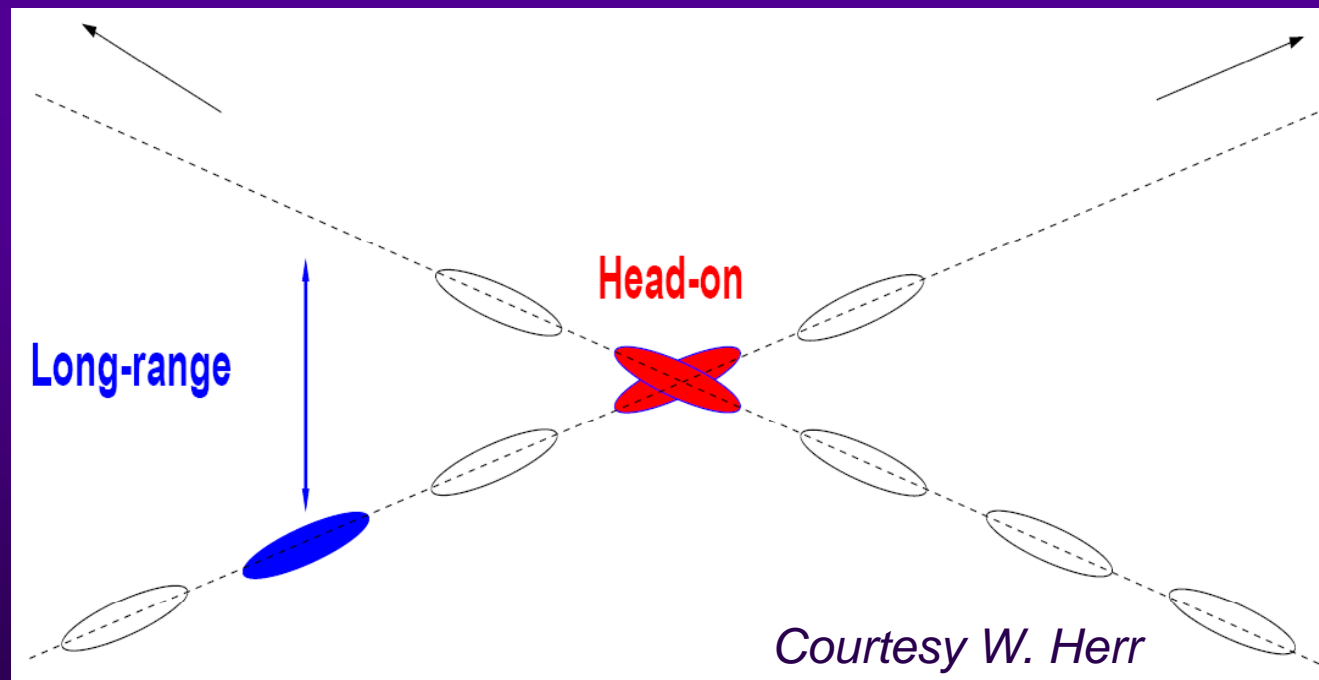

## LIMITING FACTORS FOR A SYNCHROTRON / COLLIDER ⇒ COLLECTIVE EFFECTS (26/34)

- Bunches which do not have the regular collision pattern have been named PACMAN bunches ⇒ ≠ integrated beam-beam effect
- Only 1443 bunches are regular **bunches with 4 head-on and 120 long range interactions, i.e.** about half of the bunches are not regular
- **The identification of regular bunches is important since measurements such as tune, orbit or chromaticity should be selectively performed on them**
- **SUPERPACMAN bunches are those who will miss head-on interactions**
  - **252 bunches will miss 1 head-on interaction**
  - **3 will miss 2 head-on interactions**
- **ALTERNATE CROSSING SCHEME: Crossing angle in the vertical plane for IP1 and in the horizontal plane for IP5 ⇒ The purpose is to compensate the tune shift for the Pacman bunches**

# LIMITING FACTORS FOR A SYNCHROTRON / COLLIDER ⇒ COLLECTIVE EFFECTS (27/34)

## ◆ COHERENT BEAM-BEAM EFFECT

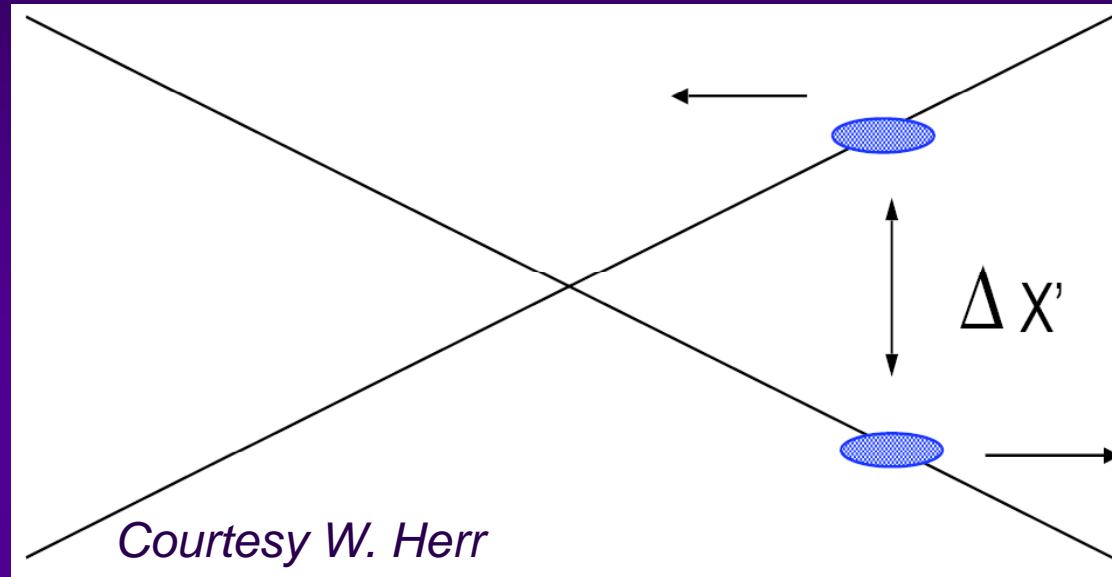

- A whole bunch sees a (coherent) kick from the other (separated) beam ⇒ Can excite coherent oscillations
- All bunches couple together because each bunch "sees" many opposing bunches ⇒ Many coherent modes possible!

# LIMITING FACTORS FOR A SYNCHROTRON / COLLIDER ⇒ COLLECTIVE EFFECTS (28/34)

## Beam-beam modes and tune spread

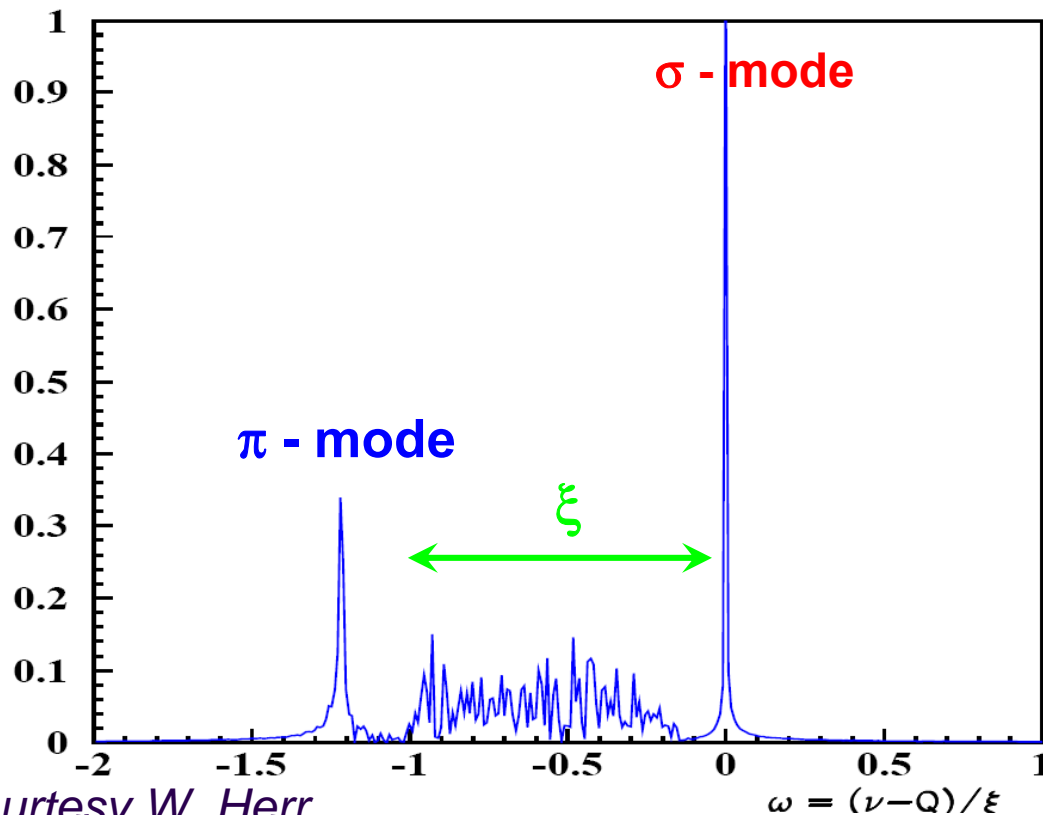

For 2 colliding bunches

- $\sigma$ -mode (in phase) is at unperturbed tune
- $\pi$ -mode (out of phase) is shifted by  $1.1 - 1.3 \xi$
- Incoherent spread between  $[0.0, 1.0] \xi$

It can be restored when the symmetry between the 2 beams is broken

⇒ Landau damping is lost  
(coherent tune of the  $\pi$ -mode not inside the incoherent tune spread)

# LIMITING FACTORS FOR A SYNCHROTRON / COLLIDER ⇒ COLLECTIVE EFFECTS (29/34)

## Electron cloud

- ◆ Schematic of electron-cloud build up in the LHC beam pipe during multiple bunch passages, via photo-emission (due to synchrotron radiation) and secondary emission

The LHC is the 1<sup>st</sup> proton storage ring for which synchrotron radiation becomes a noticeable effect

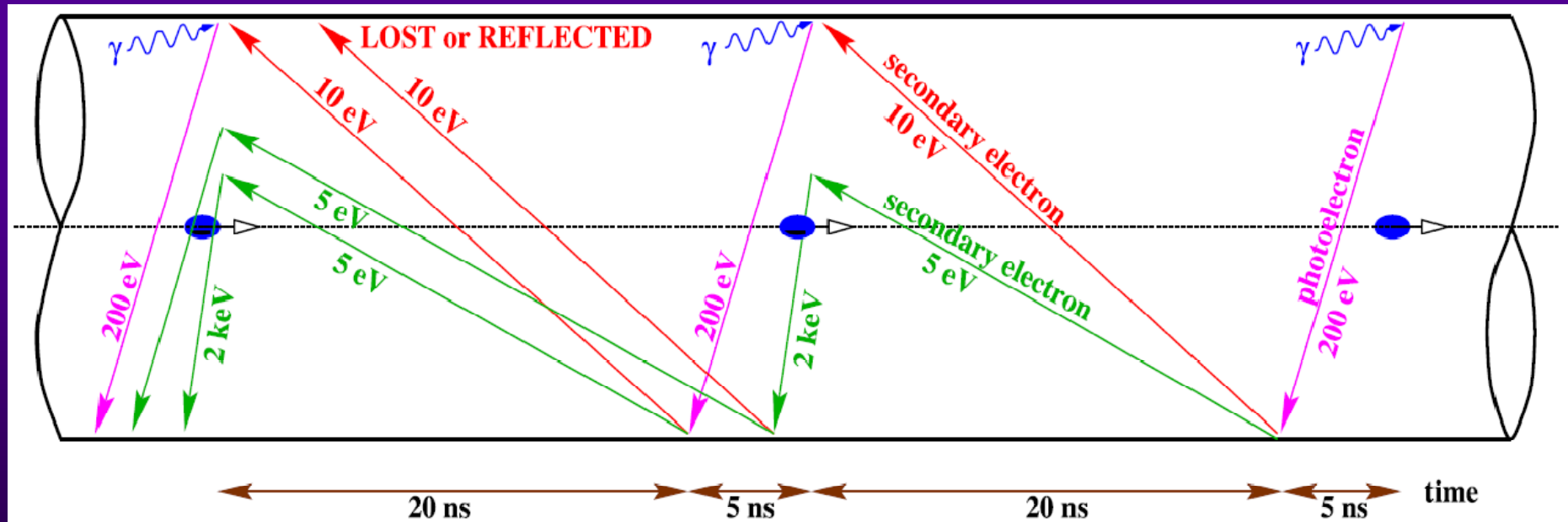

# LIMITING FACTORS FOR A SYNCHROTRON / COLLIDER ⇒ COLLECTIVE EFFECTS (30/34)

- ◆ Simulations of electron-cloud build-up along 2 bunch trains (= 2 batches of 72 bunches) of LHC beam in SPS dipole regions

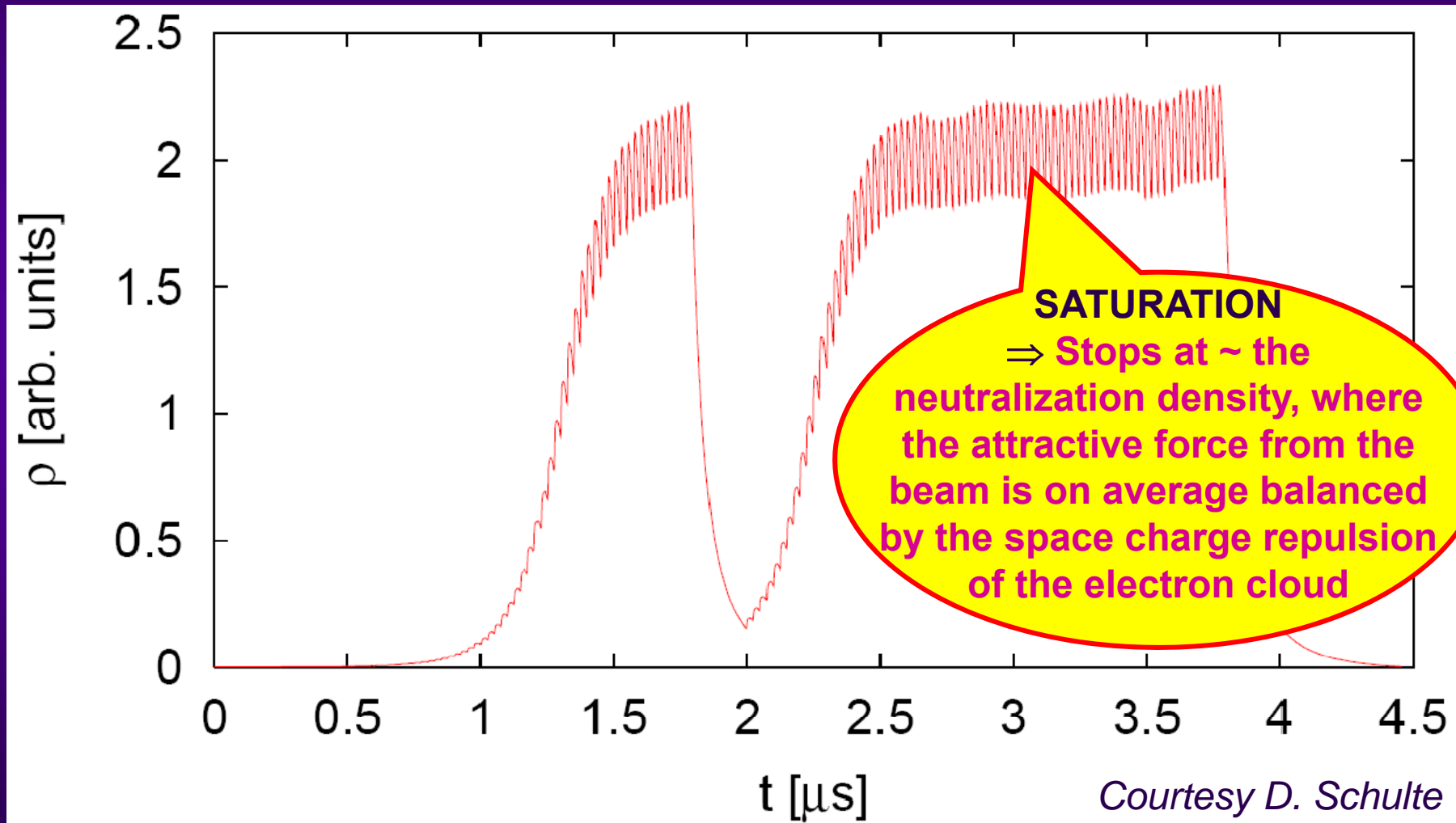



# LIMITING FACTORS FOR A SYNCHROTRON / COLLIDER ⇒ COLLECTIVE EFFECTS (31/34)

- ◆ Nominal beam for LHC seen on a Pick-Up in the TT2 transfer line

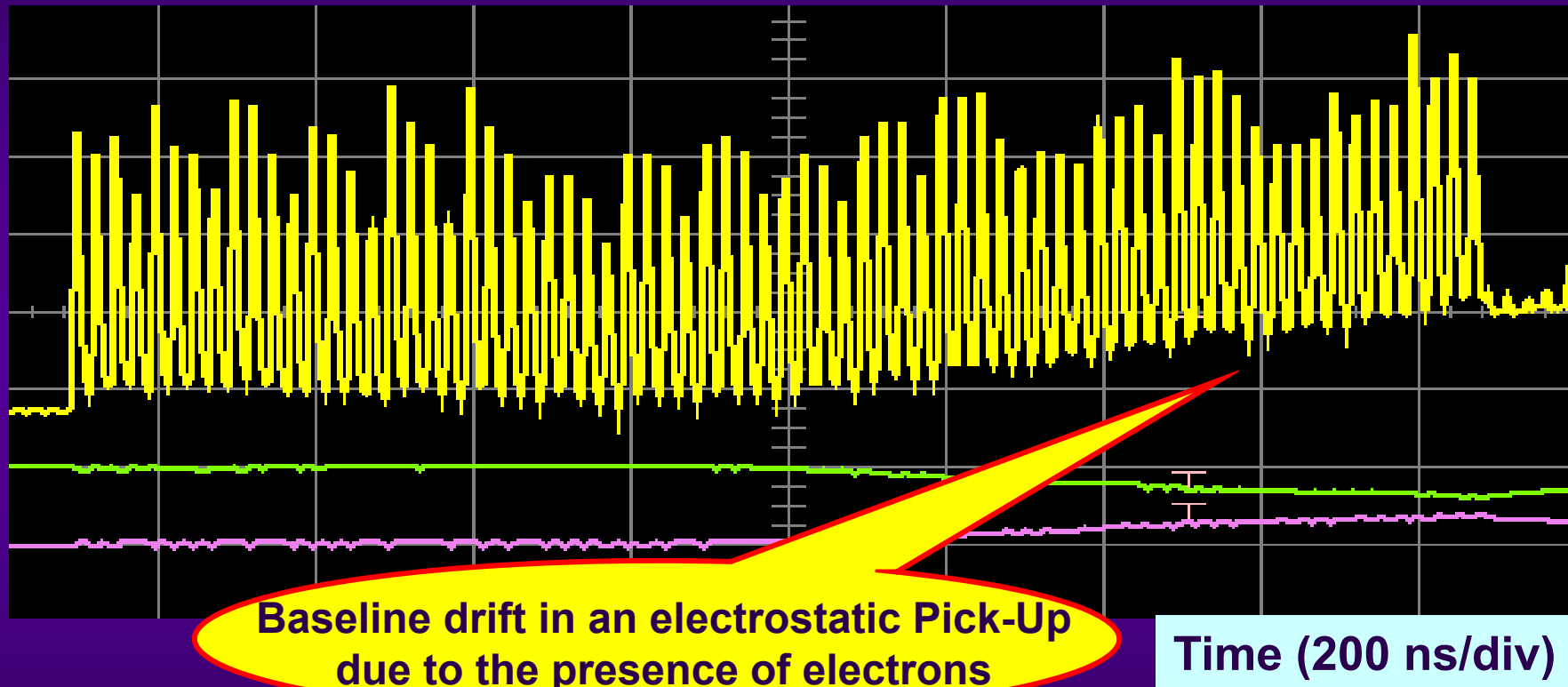

⇒ Confirmation that the electron cloud build-up is a single-pass effect

# LIMITING FACTORS FOR A SYNCHROTRON / COLLIDER ⇒ COLLECTIVE EFFECTS (32/34)

- ◆ Same as before but with a solenoidal field ( $\sim 50\text{-}100\text{ G}$ ) due to  $\sim 70$  windings before and after the 25 cm long Pick-Up device

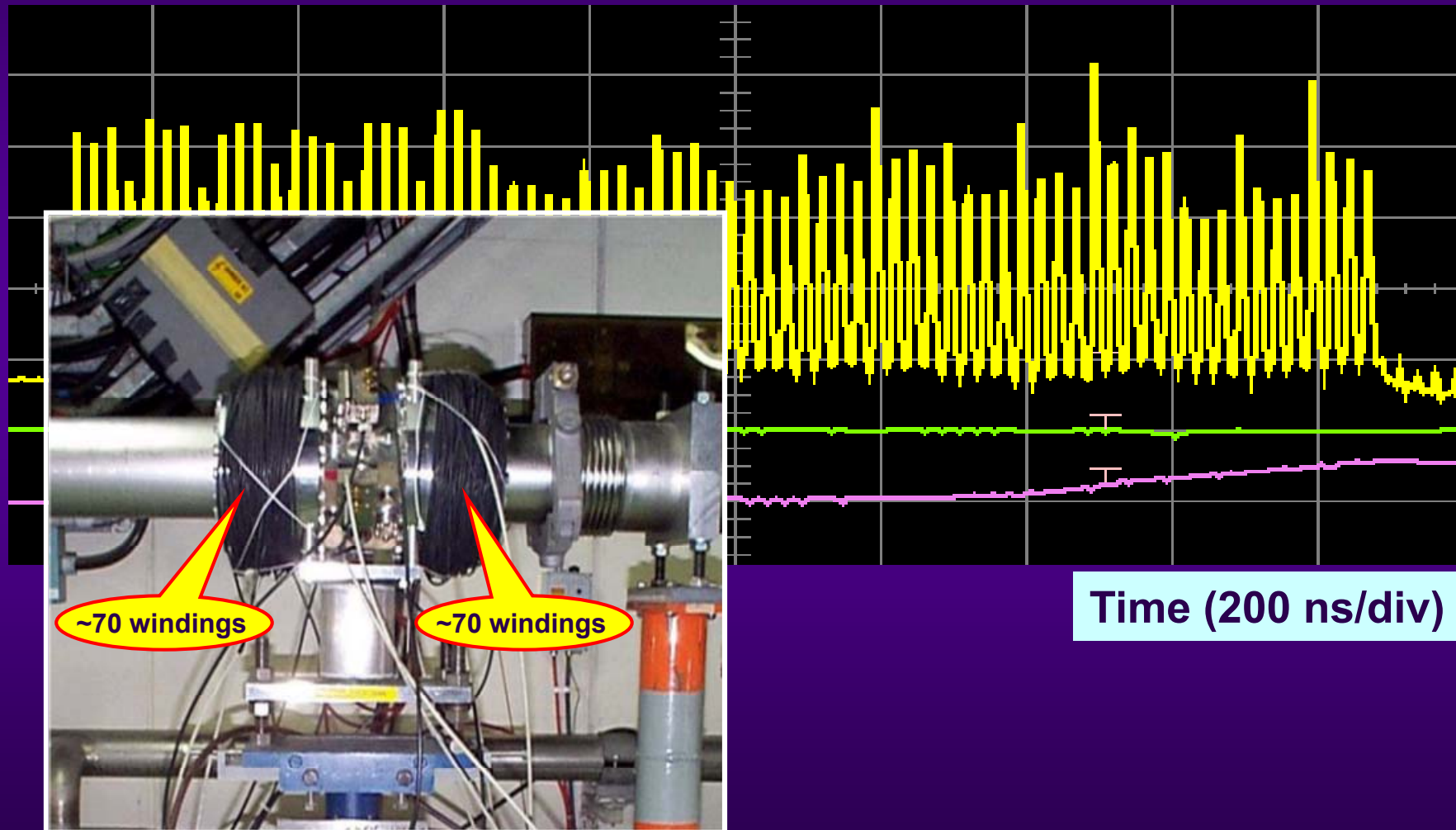

# LIMITING FACTORS FOR A SYNCHROTRON / COLLIDER ⇒ COLLECTIVE EFFECTS (33/34)

- ◆ Schematic of the single-bunch (coherent) instability induced by an electron cloud

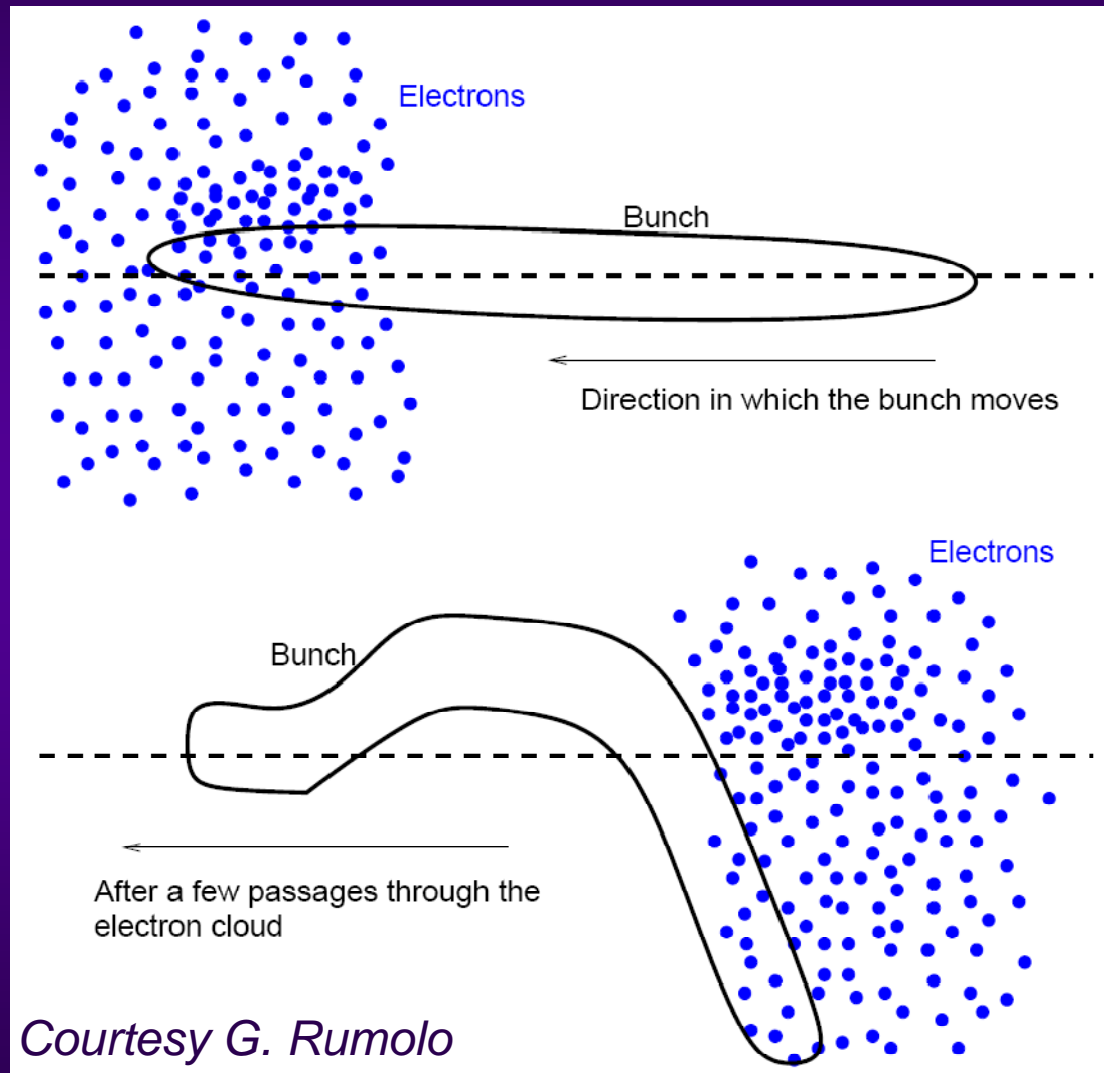

MOVIE

Single-Bunch Instability From ECloud.mpeg

*Courtesy G. Rumolo  
and F. Zimmermann*

# LIMITING FACTORS FOR A SYNCHROTRON / COLLIDER ⇒ COLLECTIVE EFFECTS (34/34)

## ◆ Incoherent effects induced by an electron cloud

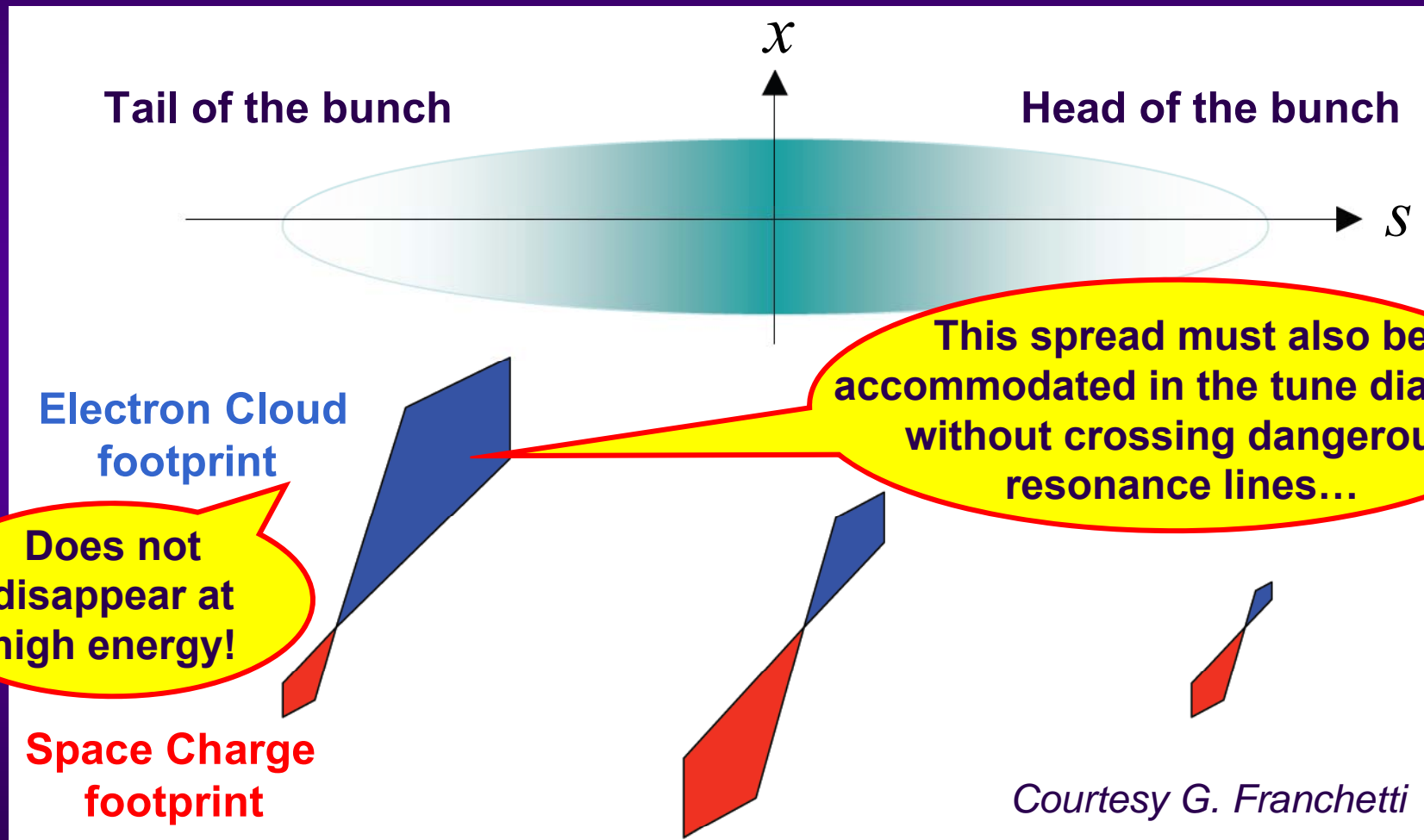

## APPENDIX A: SUMMARY OF LECTURE 2

- ◆ Design orbit **in the centre of the** vacuum chamber
- ◆ Lorentz force  $\vec{F} = e(\vec{E} + \vec{v} \times \vec{B})$
- ◆ Dipoles (**constant force**)  $\Rightarrow$  **Guide the particles along the design orbit**
- ◆ Quadrupoles (**linear force**)  $\Rightarrow$  **Confine the particles in the vicinity of the design orbit**
- ◆ Betatron oscillation **in  $x$  (and in  $y$ )**  $\Rightarrow$  **Tune  $Q_x$  (and  $Q_y$ )  $\gg 1$**
- ◆ Twiss parameters **define the ellipse in phase space** ( $x, x' = dx/ds$ )
- ◆  $\beta$ -function **reflects the size of the beam and depends only on the lattice**
- ◆ Beam emittance **must be smaller than the mechanical acceptance**
- ◆ Higher order multipoles from imperfections (**nonlinear force**)  
 $\Rightarrow$  **Resonances excited in the tune diagram and the working point ( $Q_x, Q_y$ ) should not be close to most of the resonances**
- ◆ **Nonlinearities reduce the acceptance**  $\Rightarrow$  **Dynamic aperture**
- ◆ **Injection and extraction**
- ◆ **Betatron and dispersion matching (between a circular accelerator and a transfer line)**

## APPENDIX B: SUMMARY OF LECTURE 3

- ◆ RF cavities **are used to accelerate (or decelerate) the particles**
- ◆ Transition energy and sinusoidal voltage  $\Rightarrow \vec{F} = e(\vec{E} + \vec{v} \times \vec{B})$
- ◆ Harmonic number = **Number of RF buckets (stationary or accelerating)**
- ◆ Bunched beam **(instead of an unbunched or continuous beam)**
- ◆ Synchrotron oscillation around the synchronous particle in  $z$   
 $\Rightarrow$  Tune  $Q_z \ll 1$
- ◆ Stable phase  $\phi_s$  **below transition and  $\pi - \phi_s$  above transition**
- ◆ Ellipse **in phase space** ( $\Delta t, \Delta E$ )
- ◆ Beam emittance **must be smaller than the bucket acceptance**
- ◆ Bunch splittings **and rotation very often used**
- ◆ **Figure of merit for a synchrotron/collider = Brightness/Luminosity**
- ◆ Longitudinal bunch profile **from a wall current monitor**
- ◆ Transverse beam orbit **from beam position pick-up monitors**
- ◆ Transverse beam profile **from a fast wire scanner**
- ◆ Beam losses **around the accelerator from beam loss monitors**

## APPENDIX C: SUMMARY OF LECTURE 4 (1/2)

- ◆ (Direct) space charge = **Interaction between the particles (without the vacuum chamber)**  $\Rightarrow$  Coulomb repulsion + magnetic attraction
  - Tune footprint **in the tune diagram**  $\Rightarrow$  **Interaction with resonances**
  - **Disappears at high energy**
  - **Reduces the RF bucket below transition and increases it above**
- ◆ Wake fields = **Electromagnetic fields generated by the beam interacting with its surroundings (vacuum pipe, etc.)**  $\Rightarrow$  Impedance = Fourier transform of the wake field
  - **Bunched-beam** coherent instabilities
    - Coupled-bunch **modes**
    - Single-bunch **or Head-Tail modes (low and high intensity)**
  - **Beam** stabilization
    - Landau damping
    - Feedbacks
    - **Linear coupling between the transverse planes**

## APPENDIX C: SUMMARY OF LECTURE 4 (2/2)

- ◆ **Beam-Beam = Interaction between the 2 counter-rotating beams**  
⇒ Coulomb repulsion + magnetic repulsion
  - Crossing angle, head-on and long-range interactions
  - Tune footprint **in the tune diagram** ⇒ **Interaction with resonances**
  - **Does not disappear at high energy**
  - **PACMAN effects** ⇒ **Alternate crossing scheme**
  - **Coherent modes** ⇒ **Possible loss of Landau damping**
- ◆ **Electron cloud**
  - **Electron cloud** build-up ⇒ **Multi-bunch single-pass effect**
  - **Coherent instabilities induced by the electron cloud**
    - Coupled-bunch
    - Single-bunch
  - Tune footprint **in the tune diagram** ⇒ **Interaction with resonances**
  - **Does not disappear at high energy**