

Focus Coils at Reduced Current and the Reconfiguration of MICE Step V

V. Blackmore
Imperial College, London

MICE-UK Oversight Committee
15th October, 2014

Contents

- Focus coils at reduced current
 - Historical overview
 - Impact on Step IV
 - Current plans
- Reconfiguration of MICE Step V
 - Demonstrating ionisation cooling
 - Lattice analyses
 - The reference lattice

FOCUS COILS AT REDUCED CURRENT

Historical Overview

J. Cobb

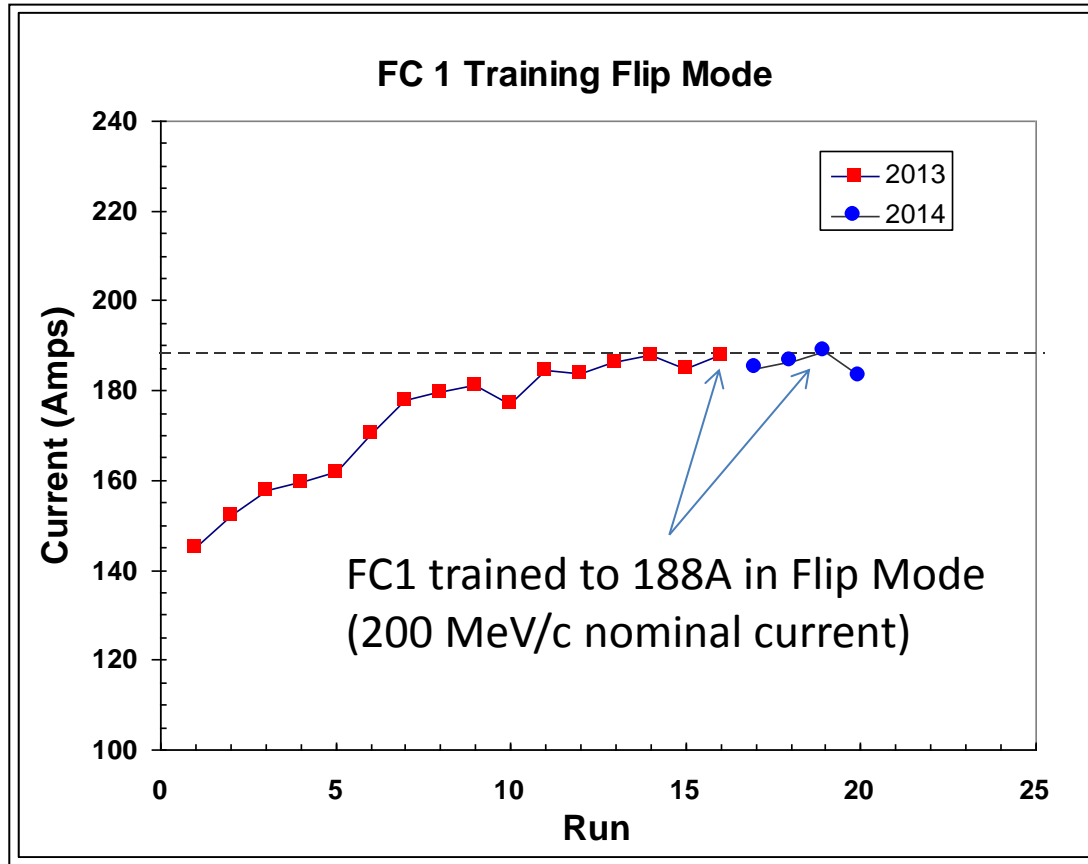

- **FC1** trained to 188A in Flip Mode (120A in Solenoid Mode)
- No operational overhead → “derate” Step IV operation to 165A
- *Question:* Could we use it in Step IV? → Yes
- FC2 trained to 225A (a happier story)

Impact on Step IV

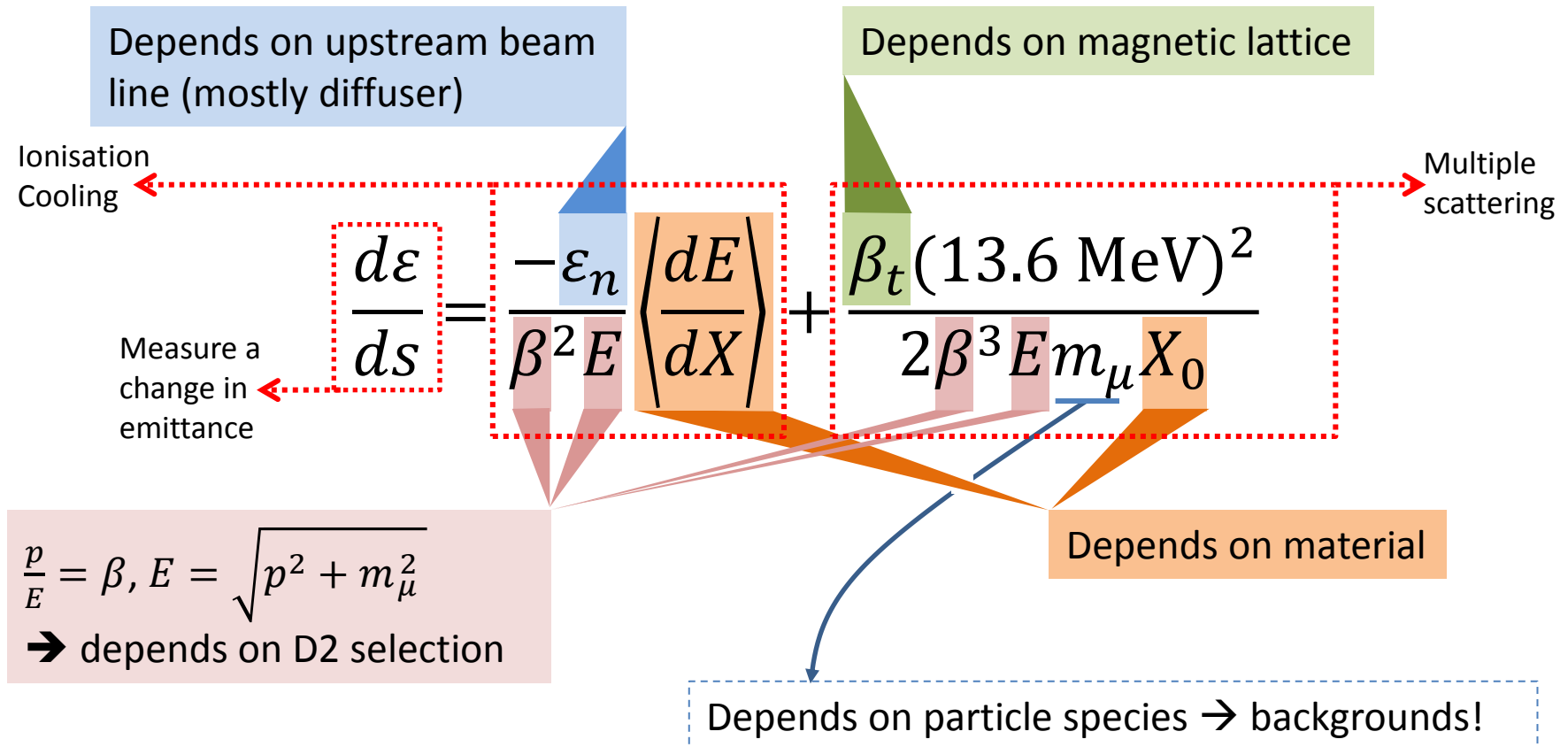

Impact on Step IV

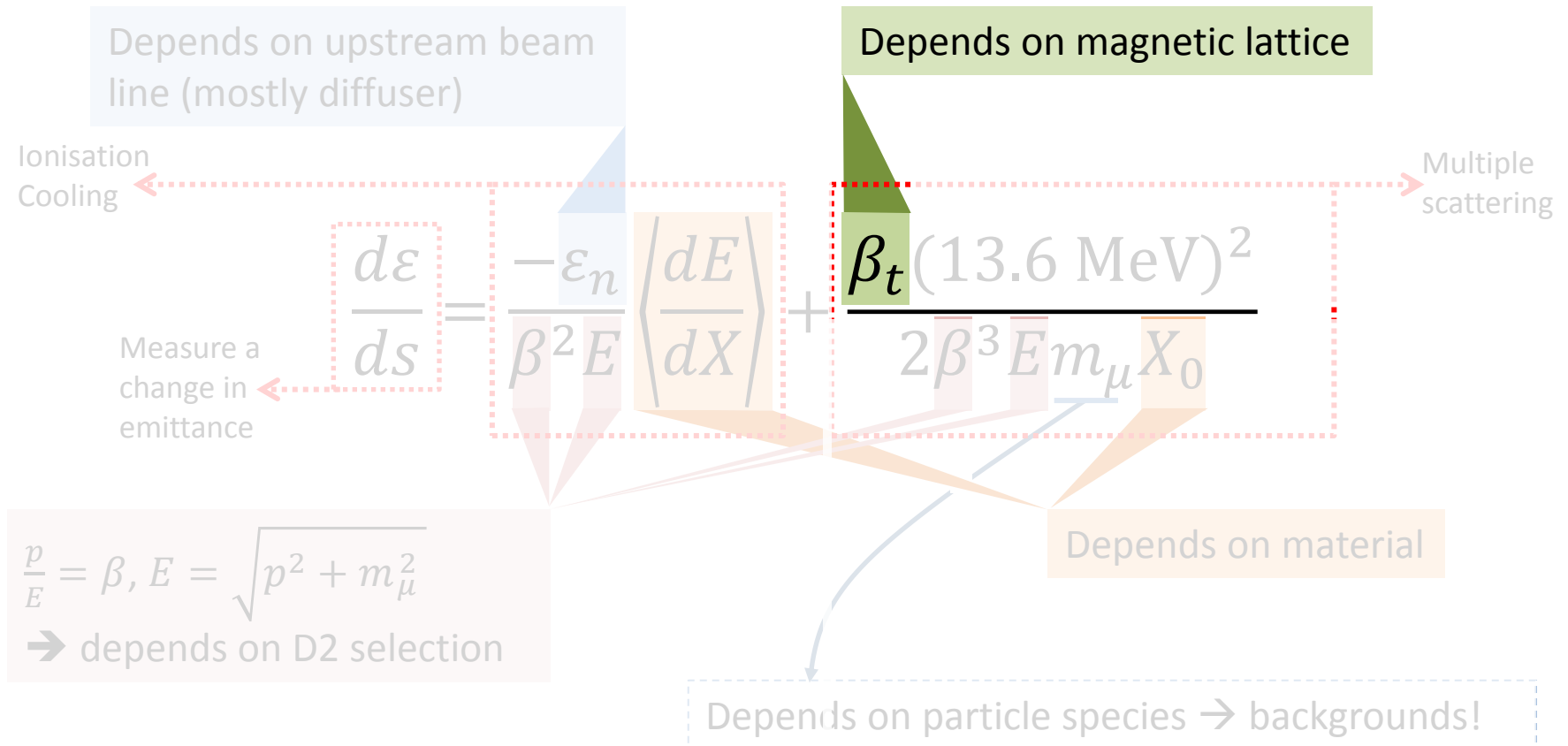

Impact on Step IV

Depends on upstream beam line (mostly diffuser)

Depends on magnetic lattice

Ionisation Cooling

Multiple scattering

β_t

Depends on material

Depends on particle species \rightarrow backgrounds!

- β_t at the absorber depends on Match Coils (in SS's) and **Focus Coil** currents
- Does the reduced operating current of Focus Coil 1 affect the measurements made at Step IV?
- Step IV: Measure the properties of the beam as a function of
 - Material
 - Initial emittance
 - Initial momentum
 - β_t at the absorber
 } Some coupling, as β_t is momentum-dependent

Impact on Step IV

C. Hunt

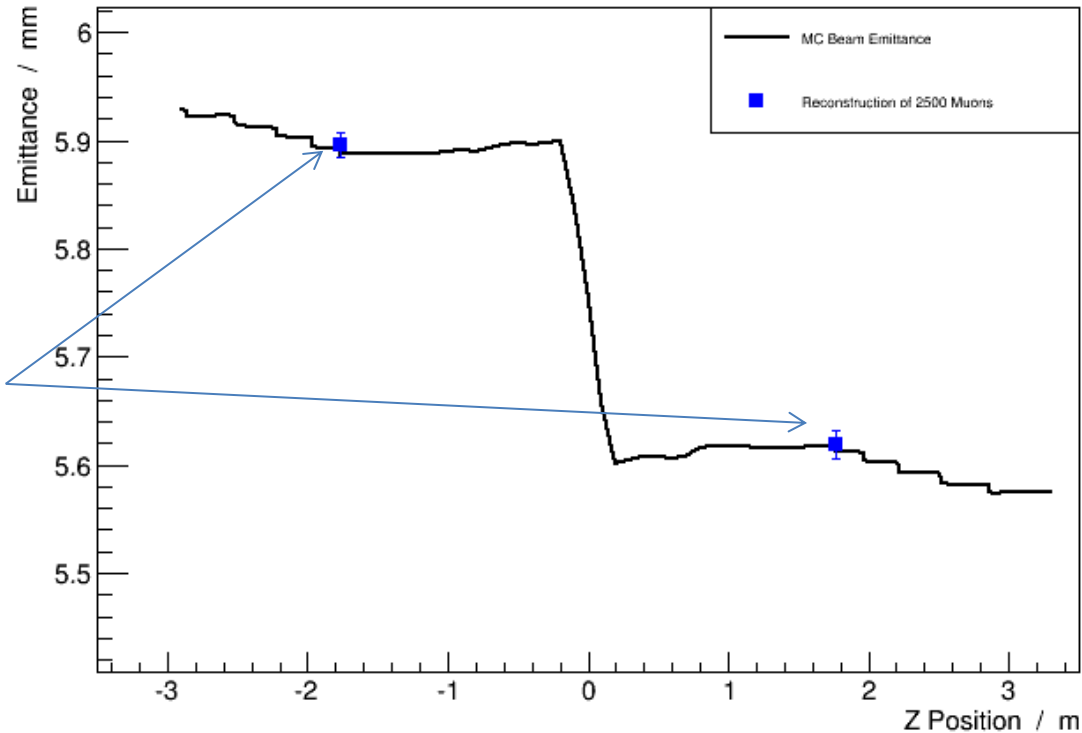

Reconstructed
emittance with
statistical errors

- Assumes FC1 operated at 160A
- Tune match coils, giving $\beta_t \sim 300$ mm
 - Smaller than 'baseline' 420 mm
- Observe reduction in emittance across liquid hydrogen absorber
- **FC1 is suitable for Step IV measurements**

BUT...

Impact on Step IV

- β_t at absorber is the parameter of interest

- Depends on Match Coils and Focus Coil currents
- Depends on momentum \rightarrow higher momentum requires stronger focussing

1. Fix Match Coils
2. Vary Focus Coil
3. Observe range of β_t at absorber
 - *Minimum* available range shown

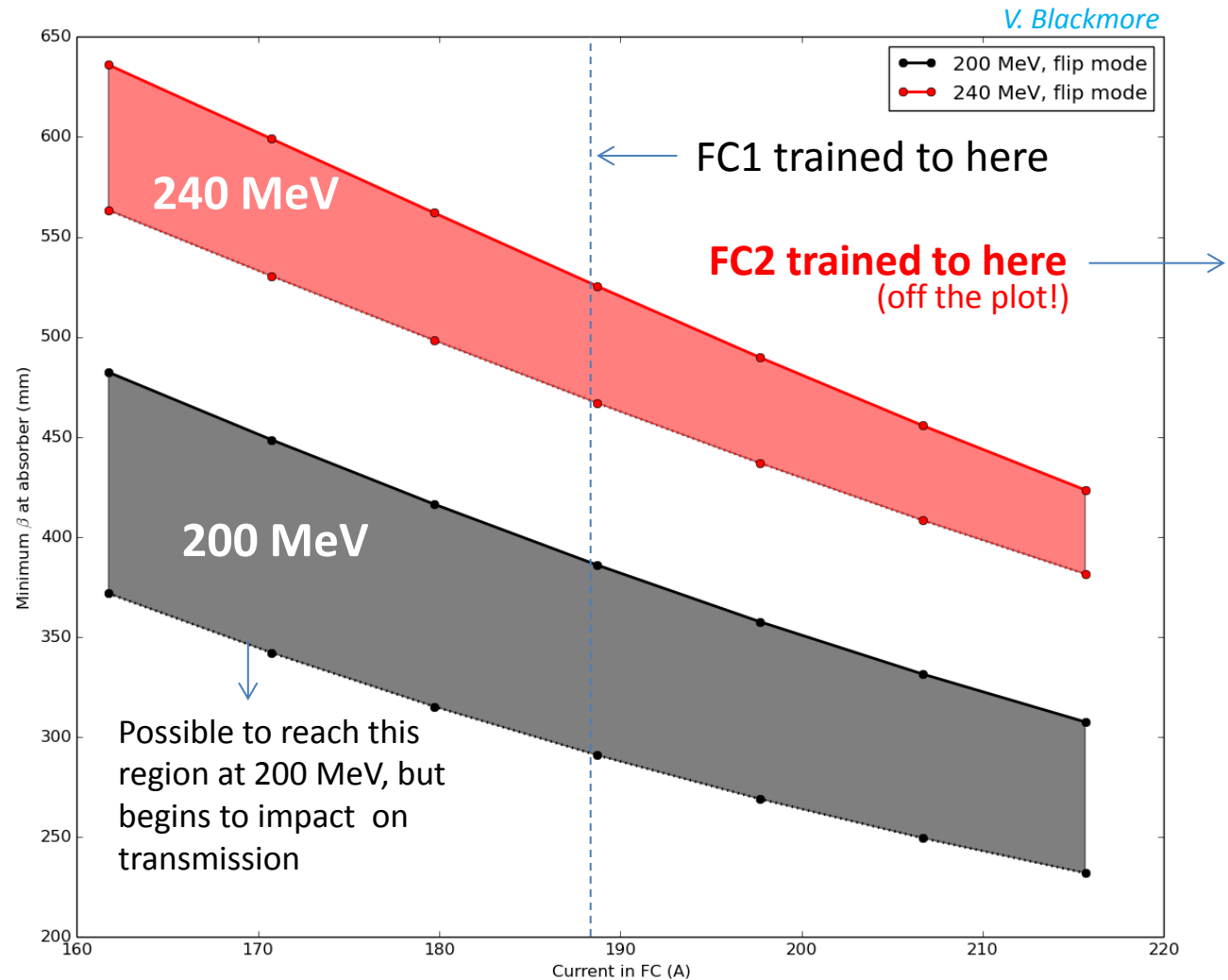

Current Plans

- FC2 increases β_t range at **all momenta**
- No need to sacrifice transmission for smallest β_t
- Time in schedule to exchange
- **Operate Step IV using FC2**

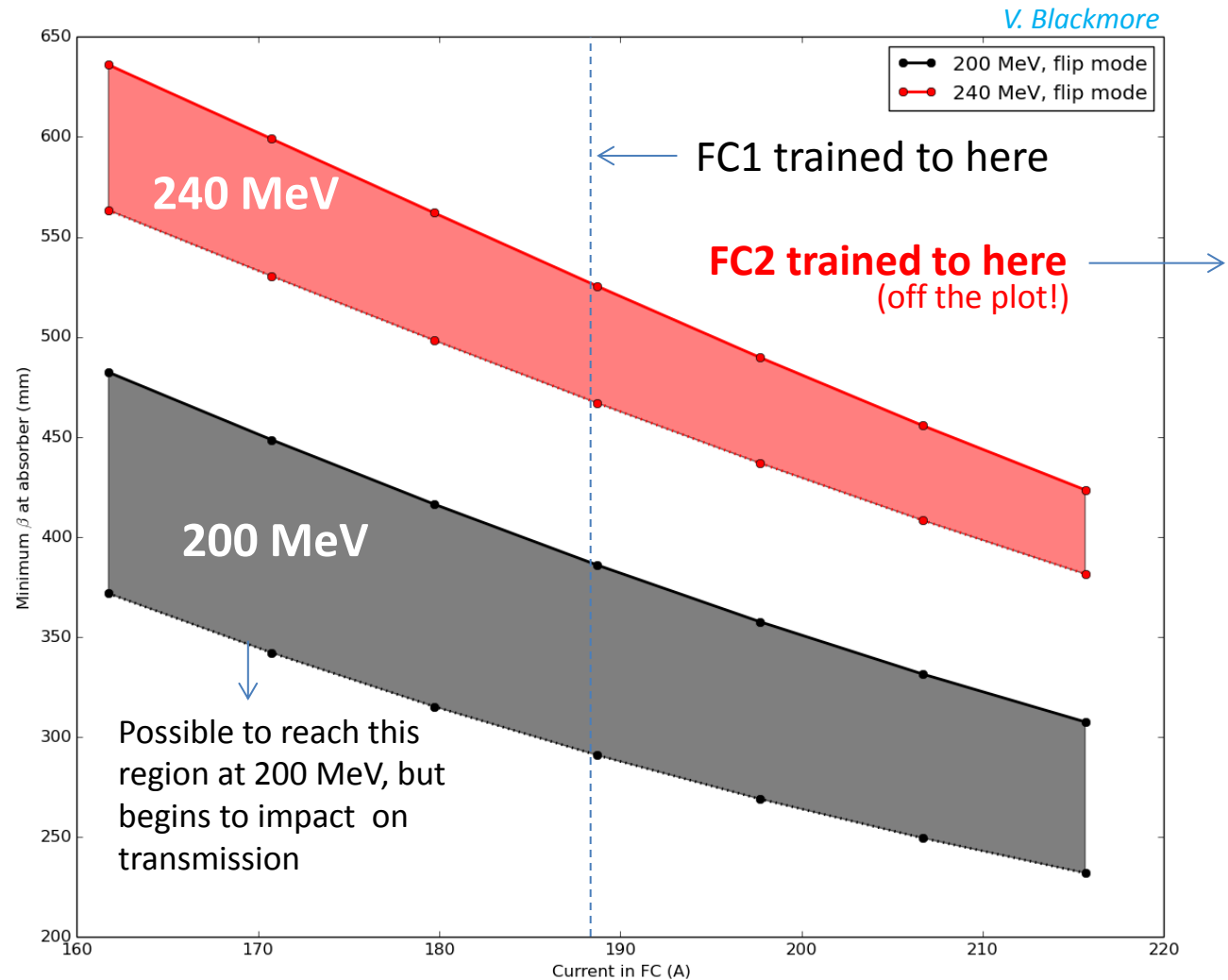

RECONFIGURATION OF MICE STEP V

Demonstrating Ionisation Cooling

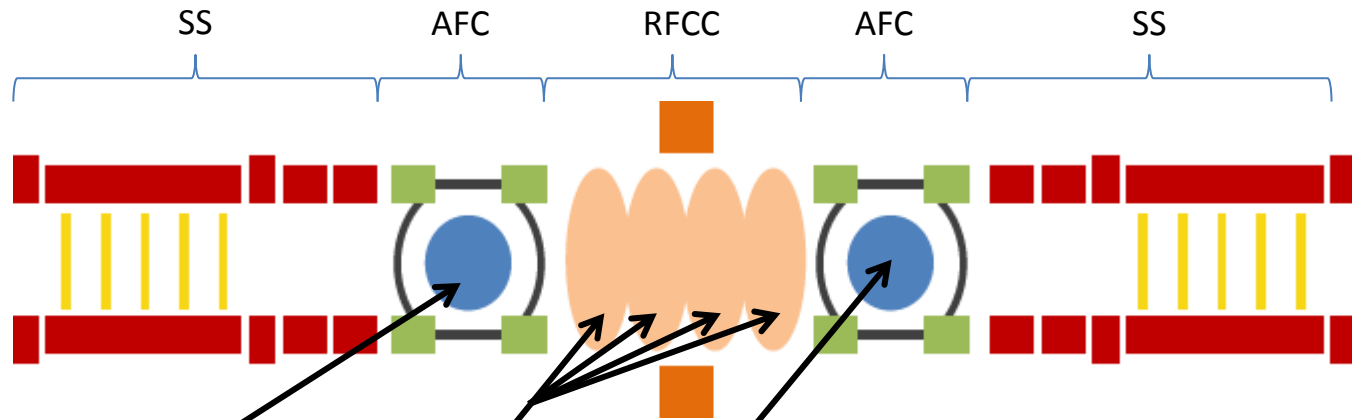

Reduce momentum vector
 → Reduce emittance

Restore longitudinal momentum
 → **Maintain beam energy**
 → **Essential demonstration**

Reduce momentum vector
 → Reduce emittance

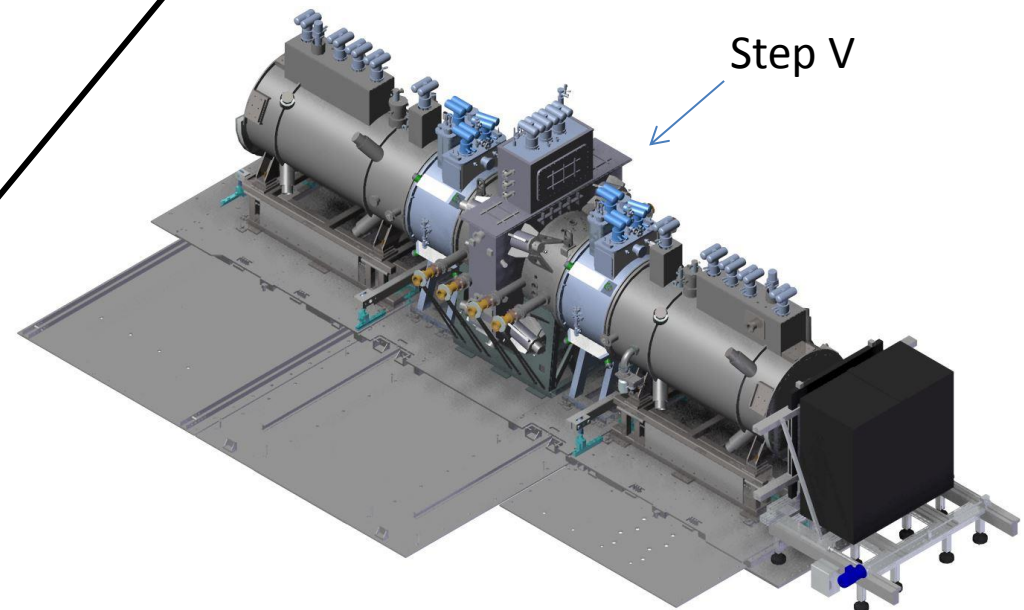

DOE Review: Question

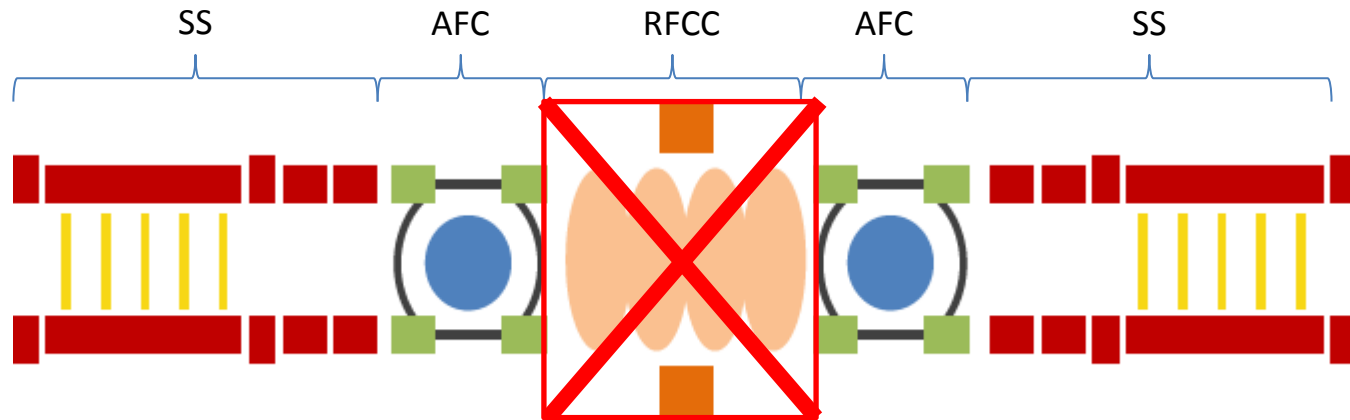

- Can we demonstrate **sustainable** ionisation cooling **without** the RFCC module?
- Available components:
 - Upstream Spectrometer Solenoid
 - Downstream Spectrometer Solenoid
 - Absorber Focus Coil #1 (limited by current)
 - Absorber Focus Coil #2 (not limited by current)
 - RF cavities
 - Single-cavity test stand designs
 - Liquid hydrogen or lithium hydride absorbers
- About 6 hours to think it over... *(we needed sleep, after all!)*

DOE Review: Answer

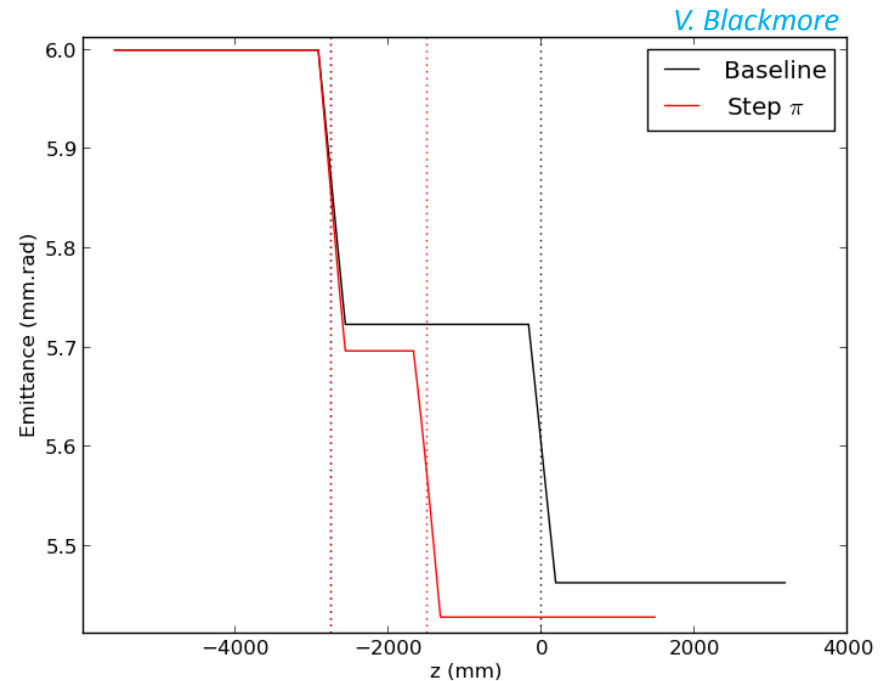
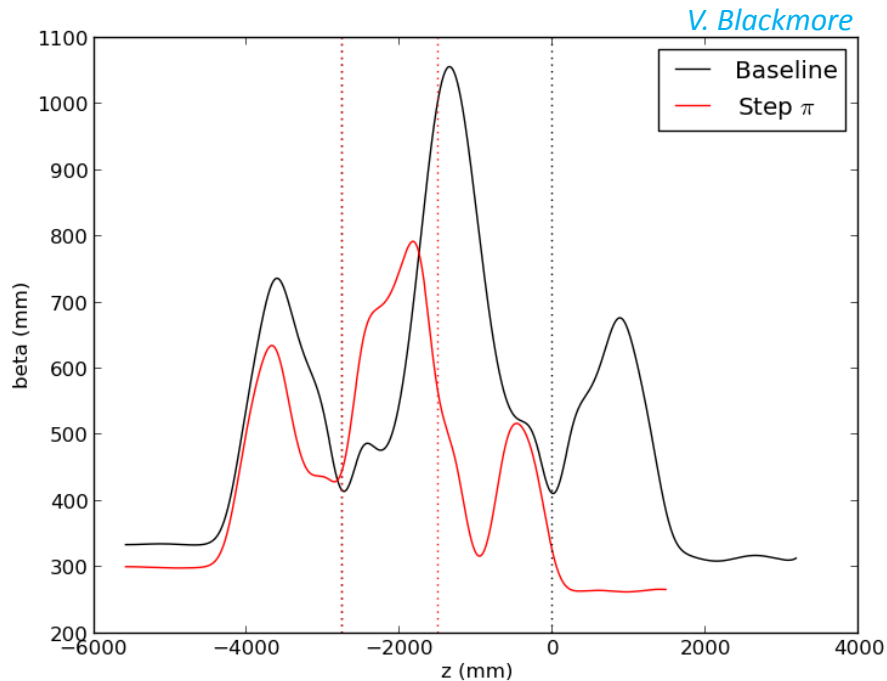

- **The answer is “Yes”**
- Can match beam through one cavity and two absorbers
- Similar performance to Step V

- **But...** this is an unstable lattice solution
- More work needed to produce the reference design (presented here)

Lattice Analyses

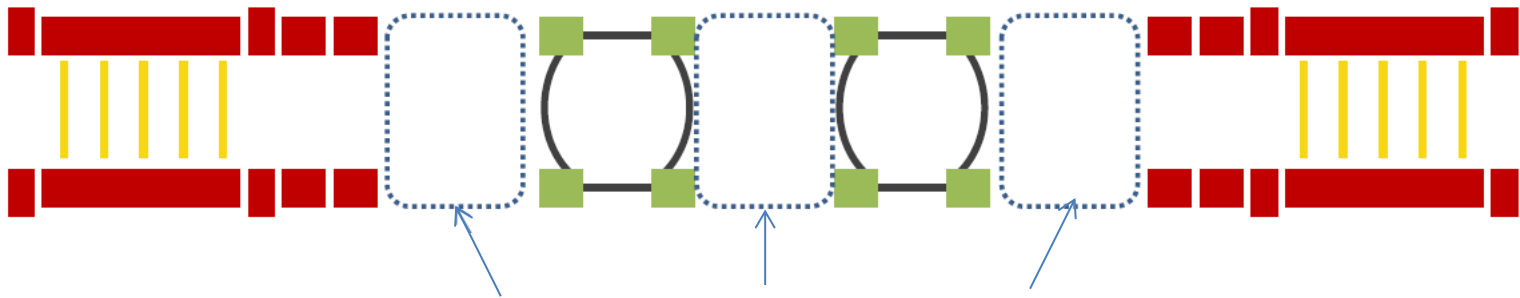

Design a new lattice by focussing on these gaps and the components that would 'fit' in them

- Two RF options:
 - RF – absorber – RF
 - Single RF cavities
- Three absorber options:
 - RF – absorber – RF
 - Absorber in AFC modules
 - Standalone absorber (outside AFC modules, LH2 or LiH)
- Options set minimum gap lengths
- Lattice solutions that allowed for more **options**, given higher priority

Lattice Analyses

Two solutions arrived at by multiple (independent) analysers:

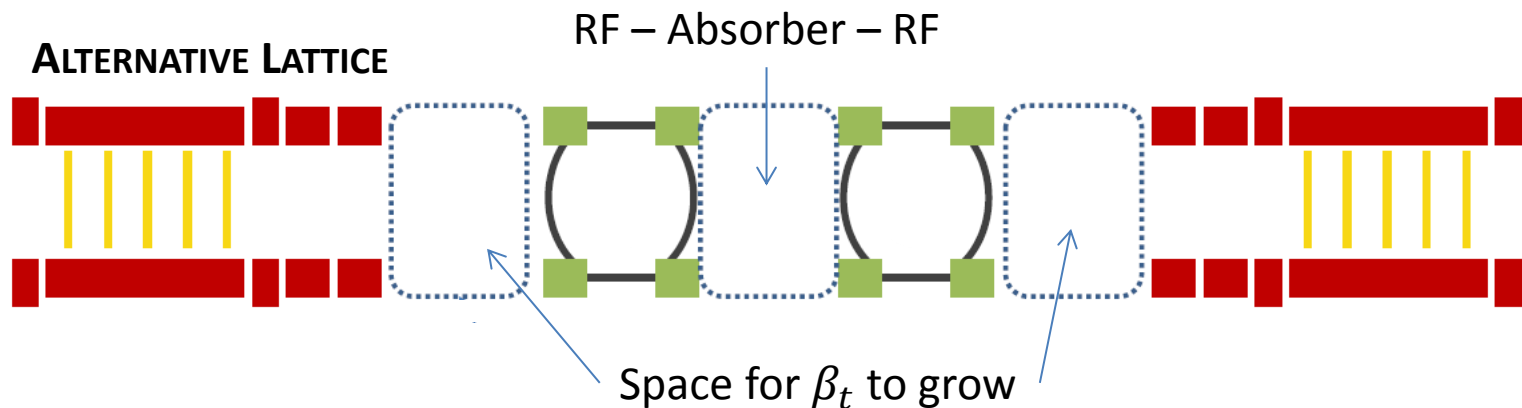
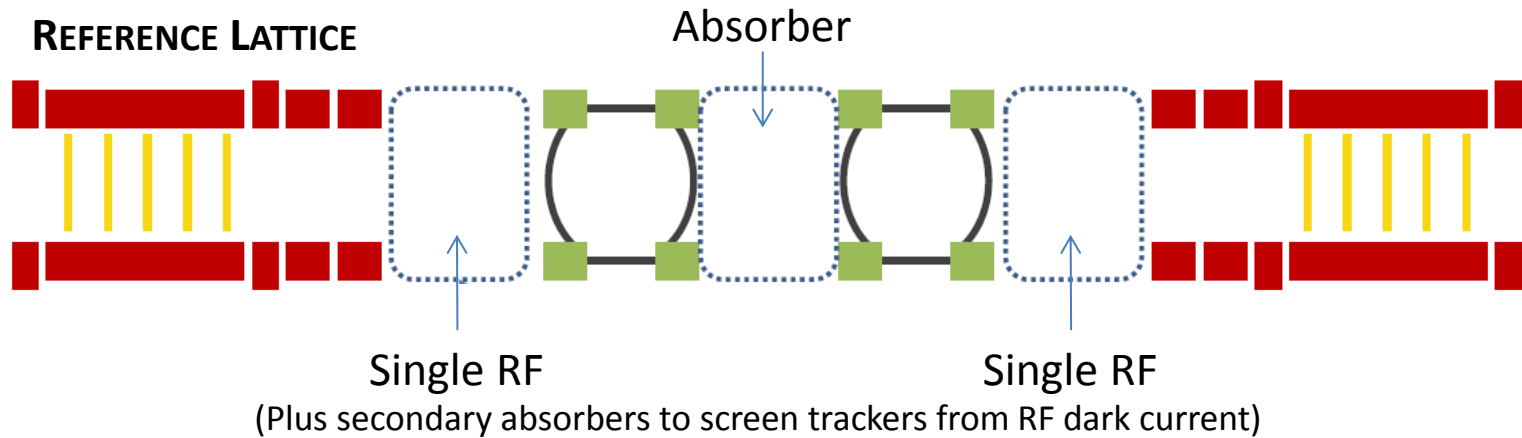

The Reference Lattice

Step V

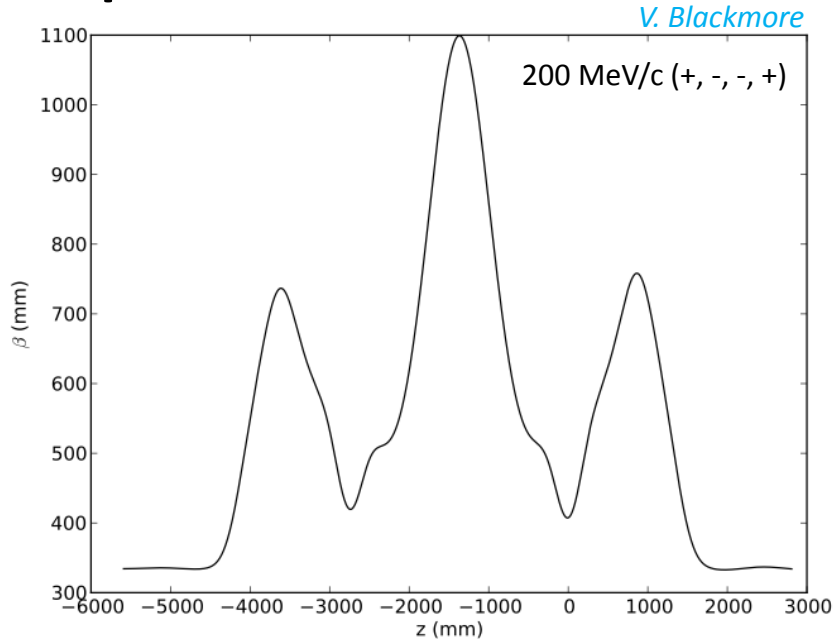

- Minimum β_t at FC's in absorber
- FC1 operating constraint limits β_t
- 4 RF cavities at 8MV/m
- 2 absorbers
- 2 materials: LH2 and LiH
- Large momentum acceptance

Reference Lattice

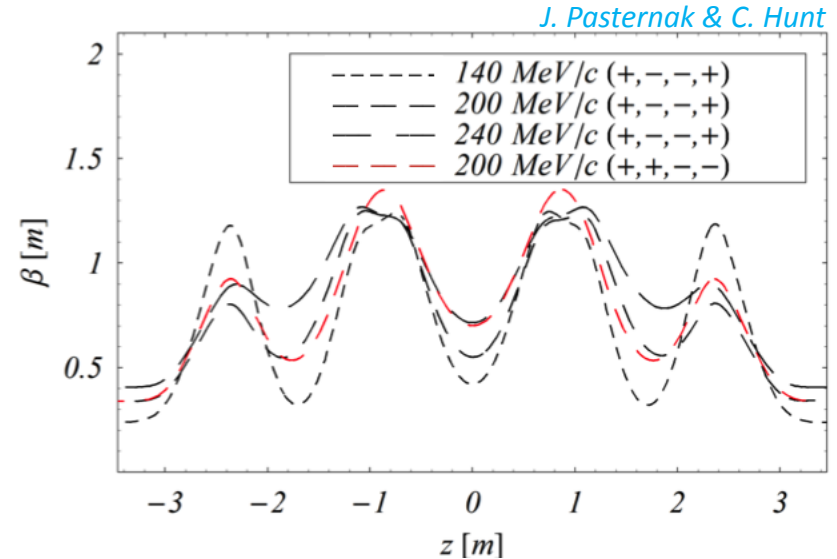

- Minimum β_t at absorber, not in FC's
- **Optimal currents beneath FC1 operating constraint for all momenta**
- 2 single RF cavities at 10.3 MV/m
- 1 main absorber + 2 'screening' absorbers
- 1 materials: LiH
- Large(r) momentum acceptance

The Reference Lattice

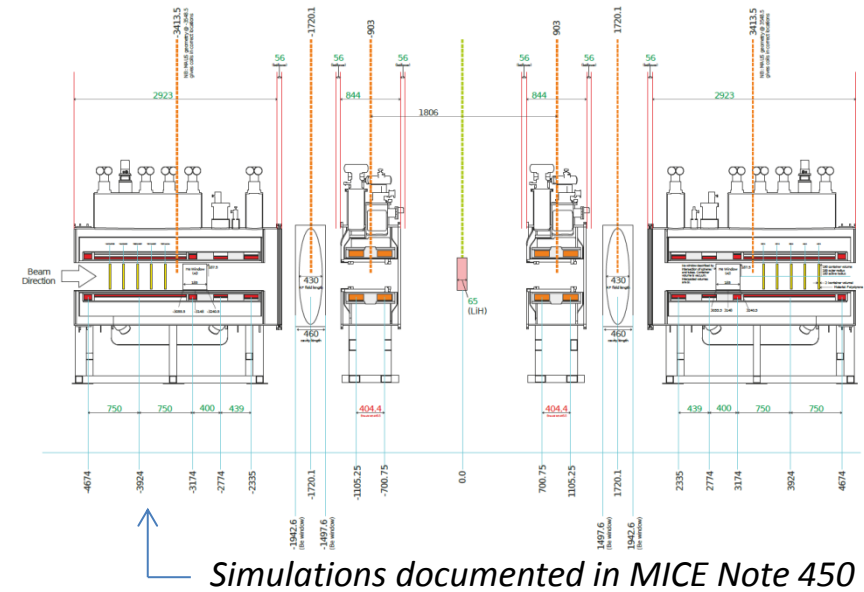
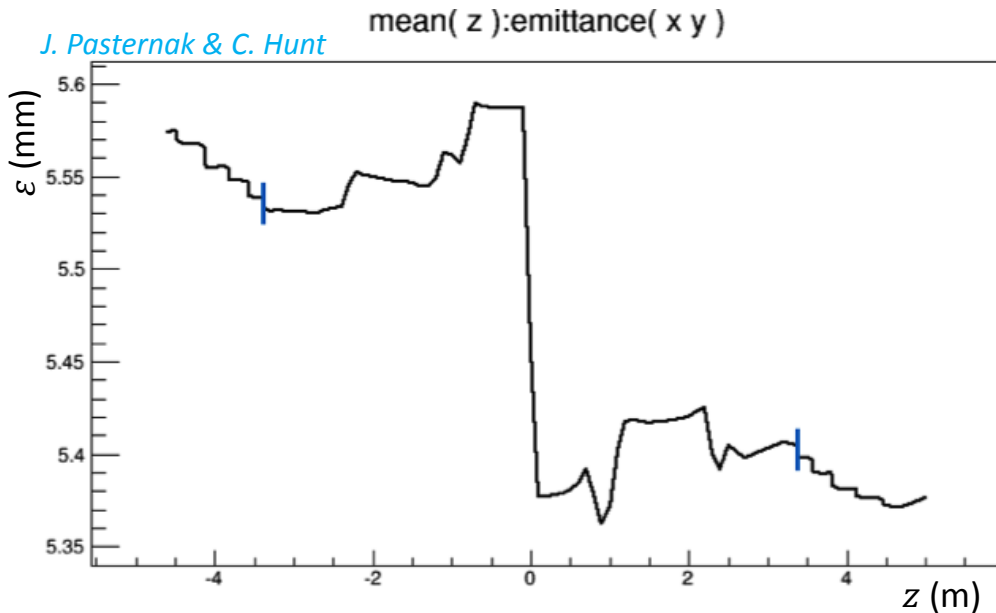

- **Measurable** emittance reduction (2.5% with LiH)
- Lattice is stable, can vary parameters as in Step IV
- Can demonstrate (partial) restoration of longitudinal momentum
- Engineering studies **in progress**
- Detailed lattice studies **in progress**

Summary

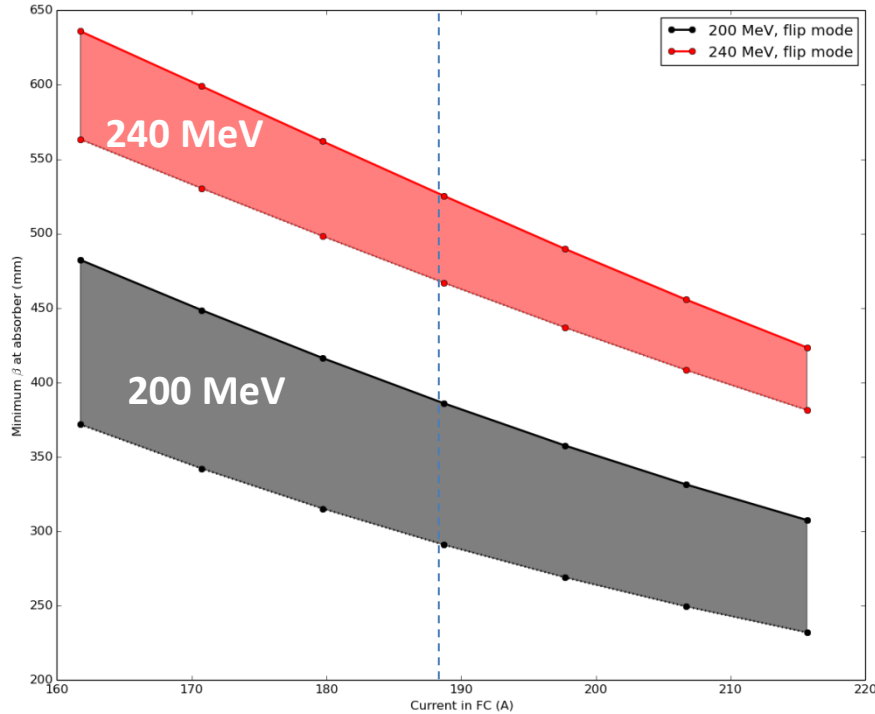

- FC2 in Step IV:
 - increases β_t options at high momentum

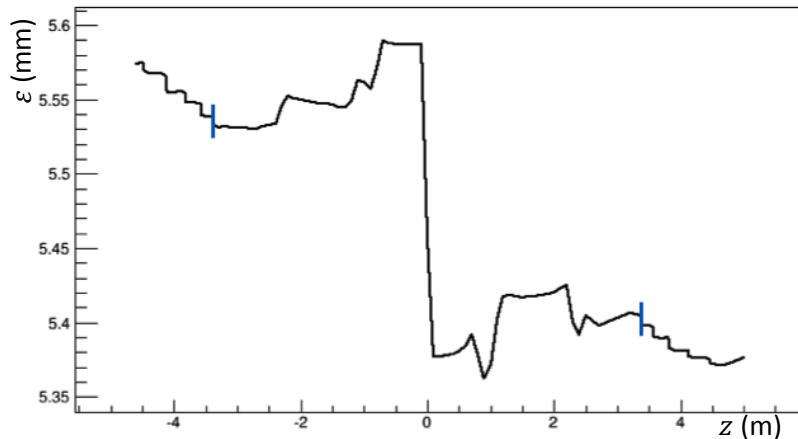

- Step V redesigned
 - Will demonstrate sustainable ionisation cooling
 - Detailed studies underway