

# Future Accelerators at the High Energy Frontier

Emmanuel Tsesmelis  
Directorate-General Unit, CERN

4<sup>th</sup> International Conference on New Frontiers in Physics  
Orthodox Academy of Crete, Kolymbari, Crete  
29 August 2015

# The Three Frontiers

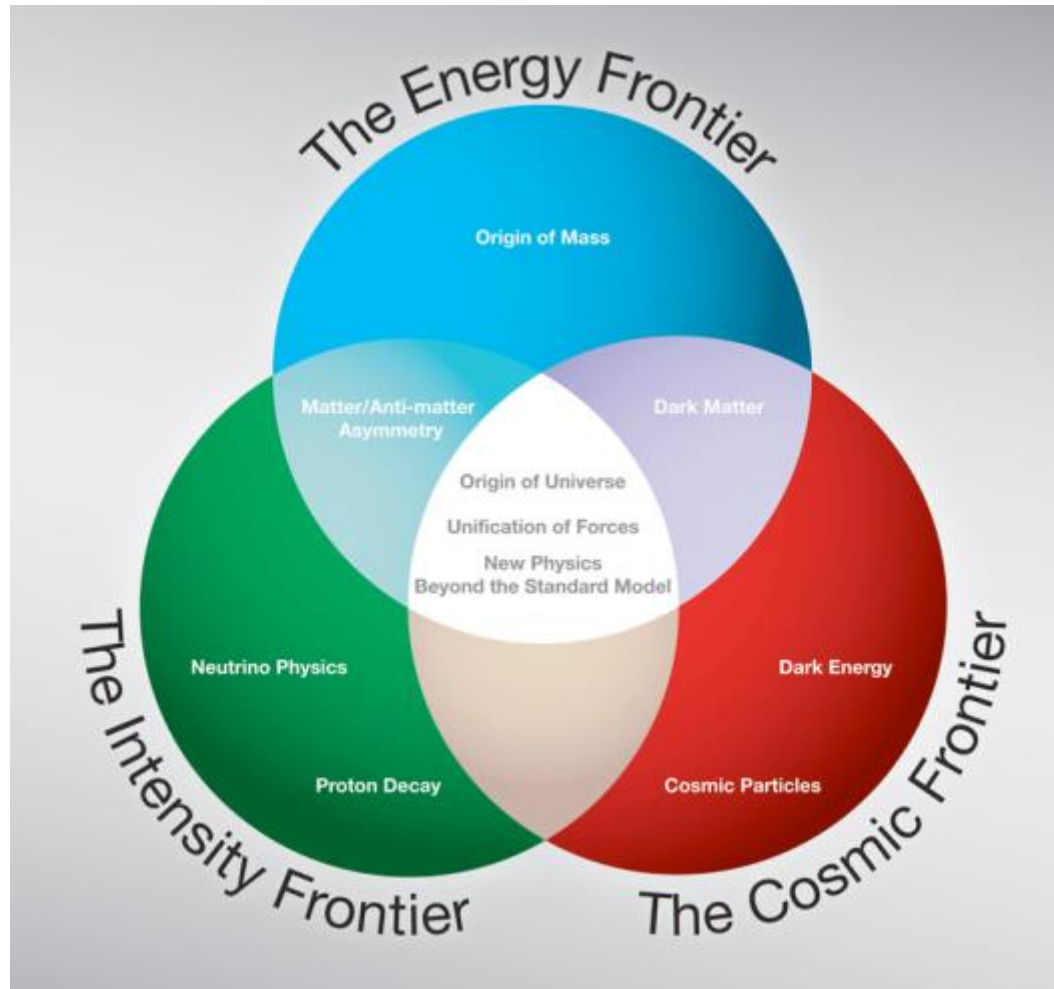

# Colliders - 2006

- In operation
- In construction

**Hadrons**  
**Leptons**  
**Leptons-Hadrons**

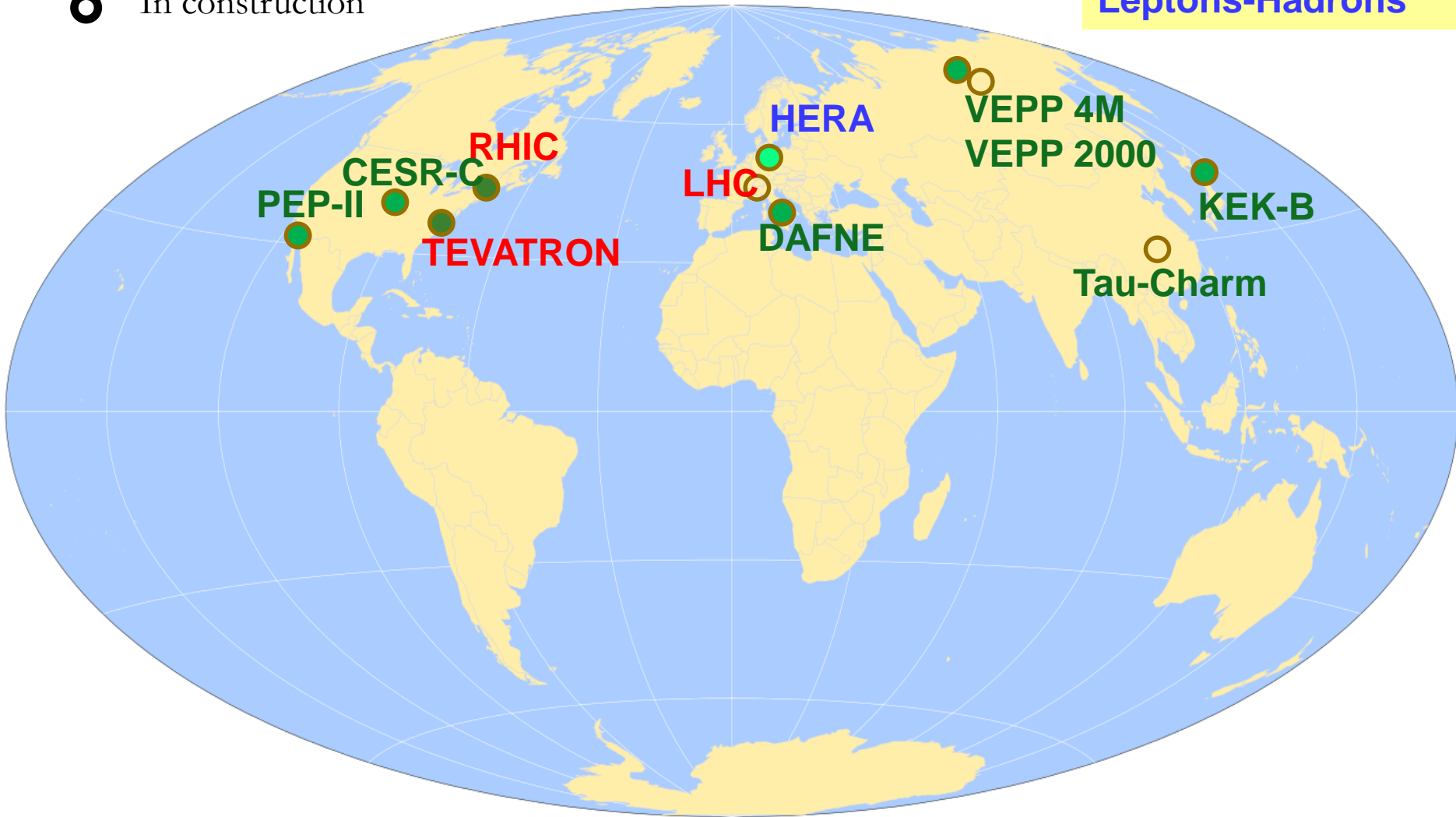

# Colliders - 2012

- In operation
- In construction

**Hadrons**  
**Leptons**  
**Leptons-Hadrons**

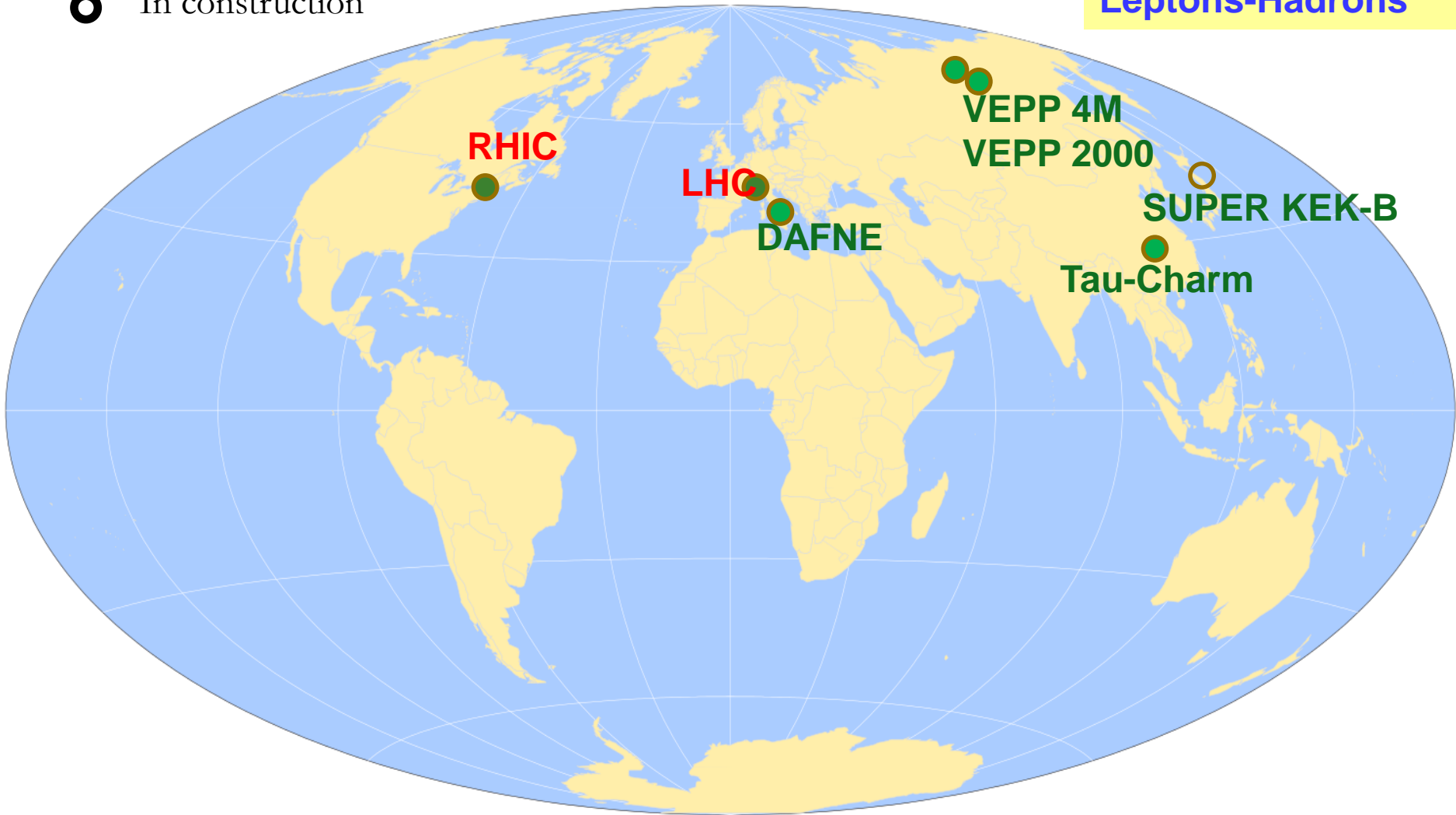

---

# THE LHC AND ITS UPGRADES

---

# CERN Accelerator Complex

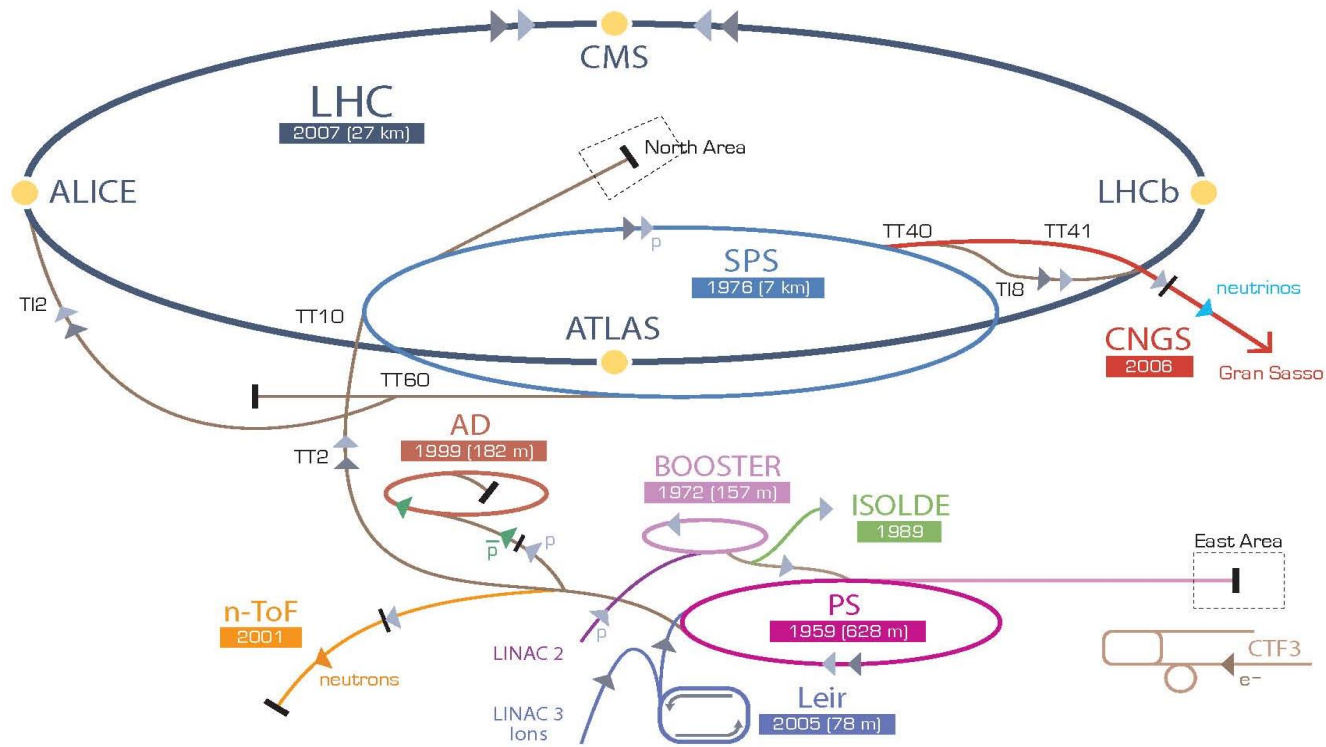

▶ p [proton] ▶ ion ▶ neutrons ▶  $\bar{p}$  [antiproton] ↔ proton/antiproton conversion ▶ neutrinos ▶ electron

LHC Large Hadron Collider SPS Super Proton Synchrotron PS Proton Synchrotron

AD Antiproton Decelerator CTF3 Clic Test Facility CNGS Cern Neutrinos to Gran Sasso ISOLDE Isotope Separator OnLine DEvice

LEIR Low Energy Ion Ring LINAC LINear ACcelerator n-ToF Neutrons Time Of Flight

# A New Era in Fundamental Science



CMS



LHCb

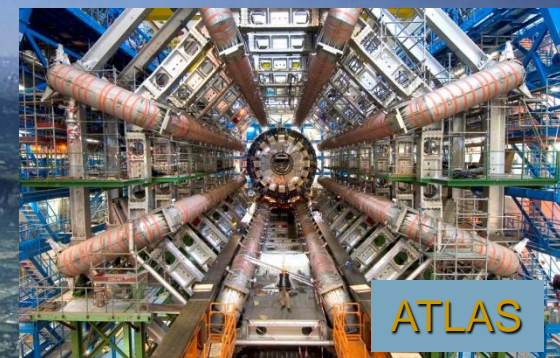

ATLAS



Exploration of a new energy frontier  
in p-p and Pb-Pb collisions



LHC ring:  
27 km circumference



ALICE

# PROTON PHYSICS: STABLE BEAMS

Energy:

6500 GeV

I(B1):

2.93e+11

I(B2):

2.96e+11

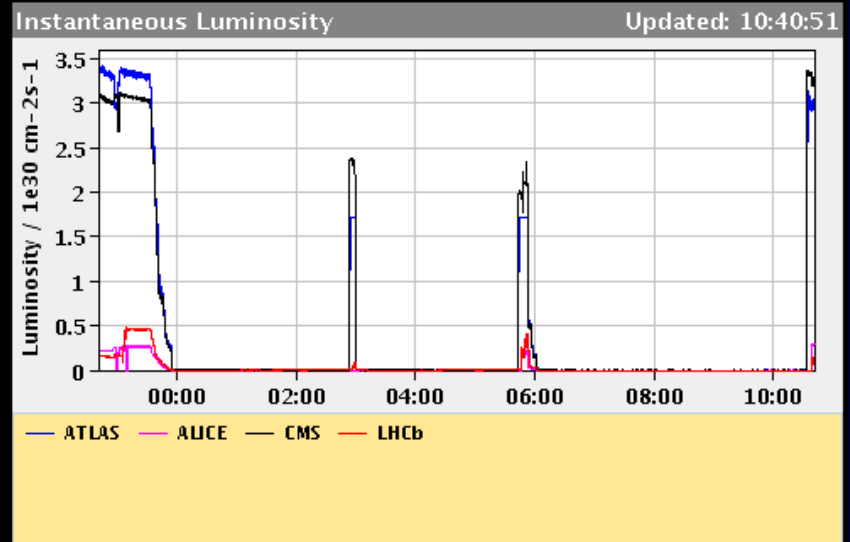
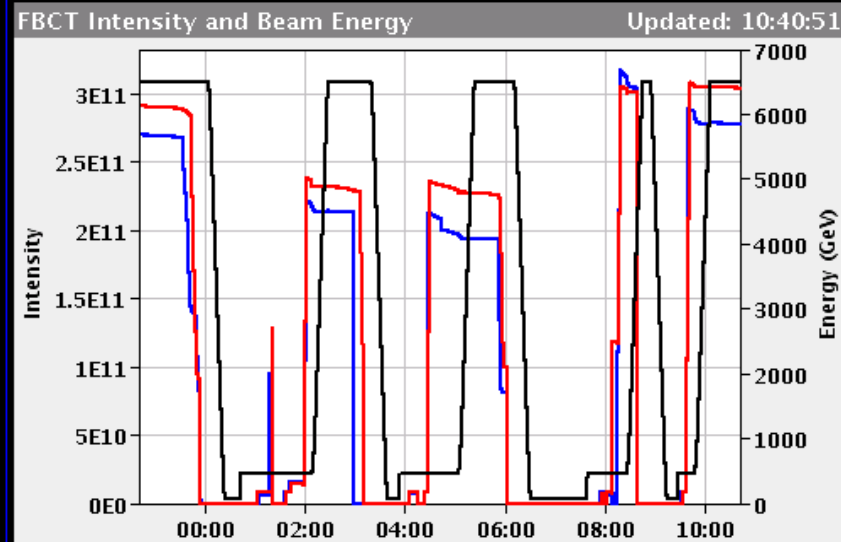

## BIS status and SMP flags

B1

B2

## Comments (03-Jun-2015 10:40:01)

collapsed separation bumps in IP1 and 5  
collapsed separation bumps in IP2 and 8  
preparing for stable beams

Link Status of Beam Permits

false

false

Global Beam Permit

true

true

Setup Beam

false

false

Beam Presence

true

true

Moveable Devices Allowed In

true

true

Stable Beams

true

true

AFS: Single\_3b\_2\_2\_2\_with\_nc\_probes

PM Status B1

ENABLED

PM Status B2

ENABLED

# The Predictable Future - *LHC Timeline*

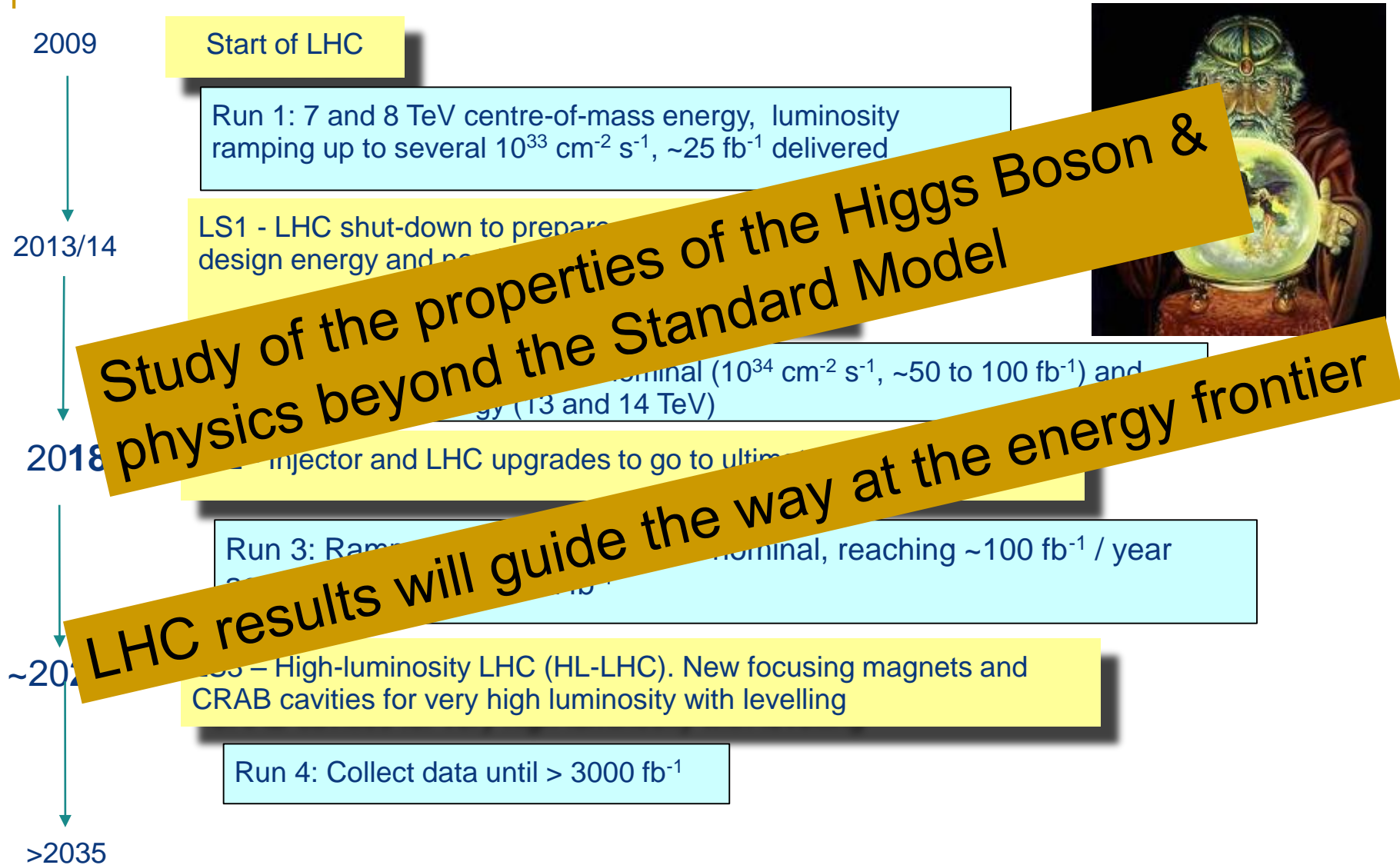

***Under review for CERN MTP***

# HL-LHC: In-kind Contribution and Collaboration for Design and Prototypes

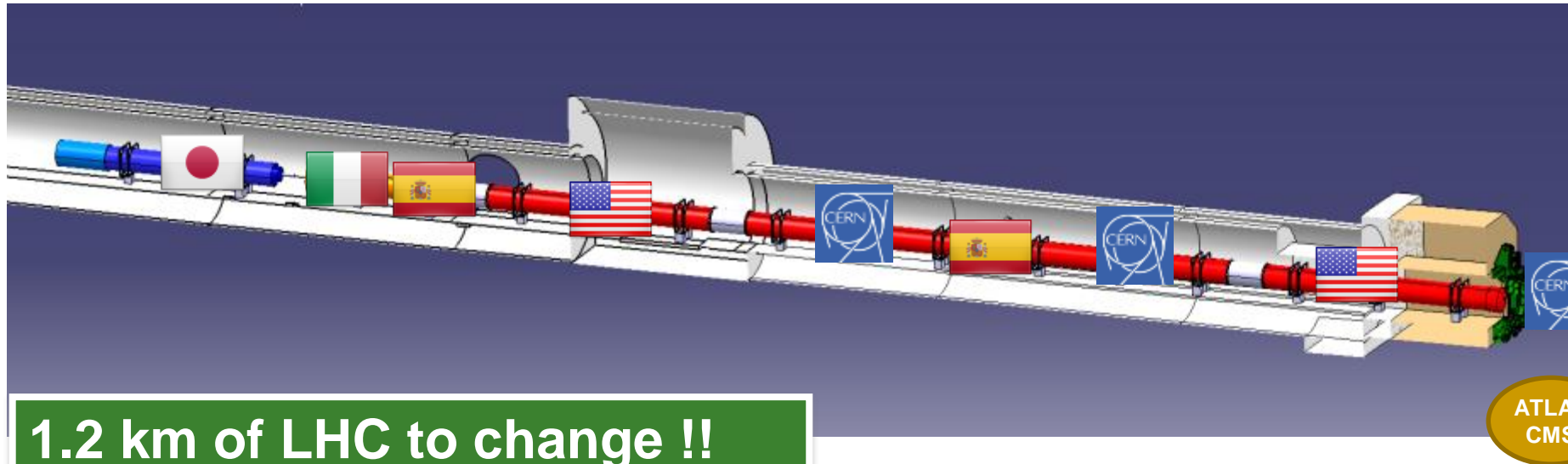

1.2 km of LHC to change !!

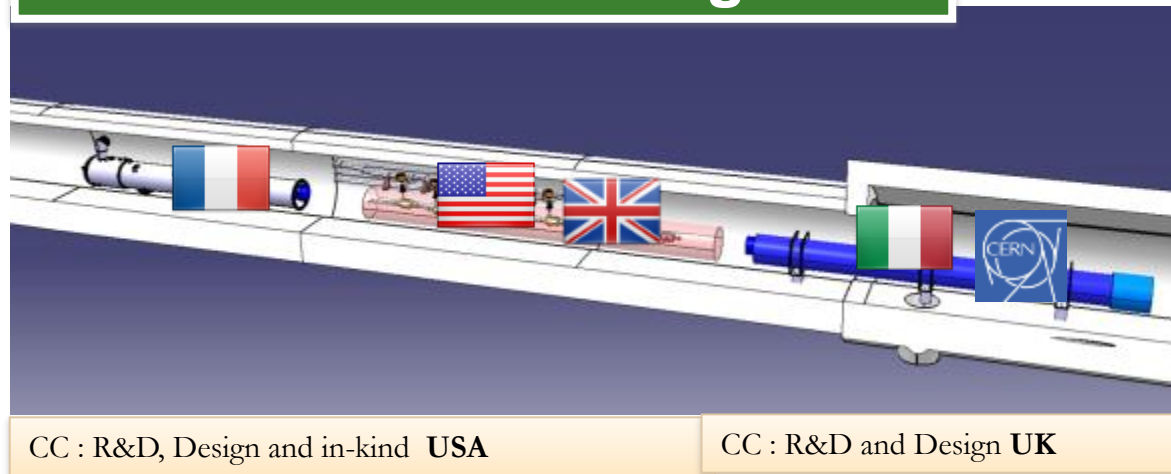

CC : R&D, Design and in-kind **USA**

CC : R&D and Design **UK**

Q1-Q3 : R&D, Design, Prototypes and in-kind **USA**

D1 : R&D, Design, Prototypes and in-kind **JP**

MCBX : Design and Prototype **ES**

HO Correctors: Design and Prototypes **IT**

Q4 : Design and Prototype **FR**

---

**BEYOND THE LHC**  
***CIRCULAR COLLIDERS***

---

# Future Circular Collider Study - SCOPE

## CDR and cost review for the next ESU (2018)

Forming an international collaboration to study:

- $pp$ -collider (*FCC-hh*) →  
defining infrastructure requirements

**~16 T  $\Rightarrow$  100 TeV  $pp$  in 100 km**  
**~20 T  $\Rightarrow$  100 TeV  $pp$  in 80 km**

- $e^+e^-$  collider (*FCC-ee*) as potential intermediate step
- $p-e$  (*FCC-he*) option
- 80-100 km infrastructure in Geneva area

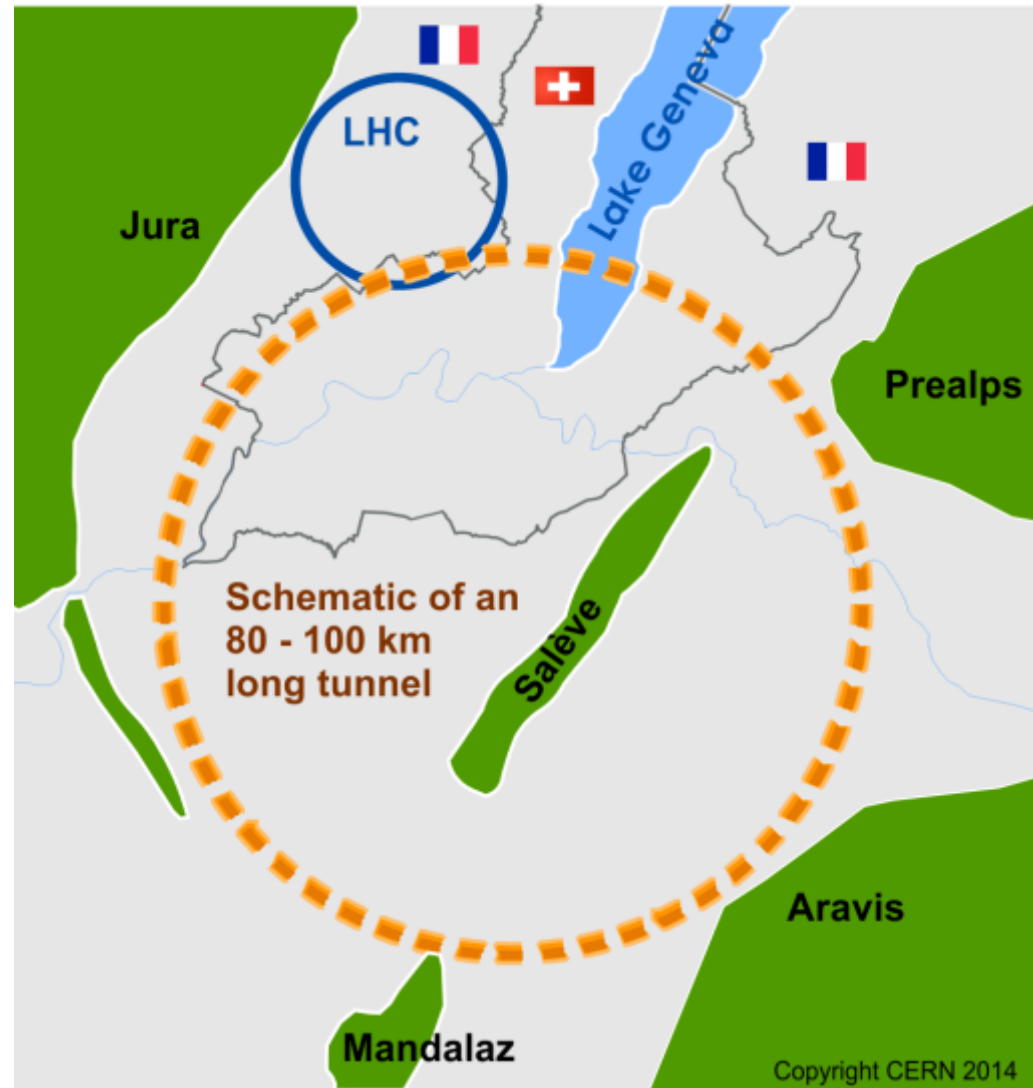

# High-Energy LHC (HE-LHC)?

**HE-LHC >2035**  
**16.5 TeV**  
**20 T Dipoles**

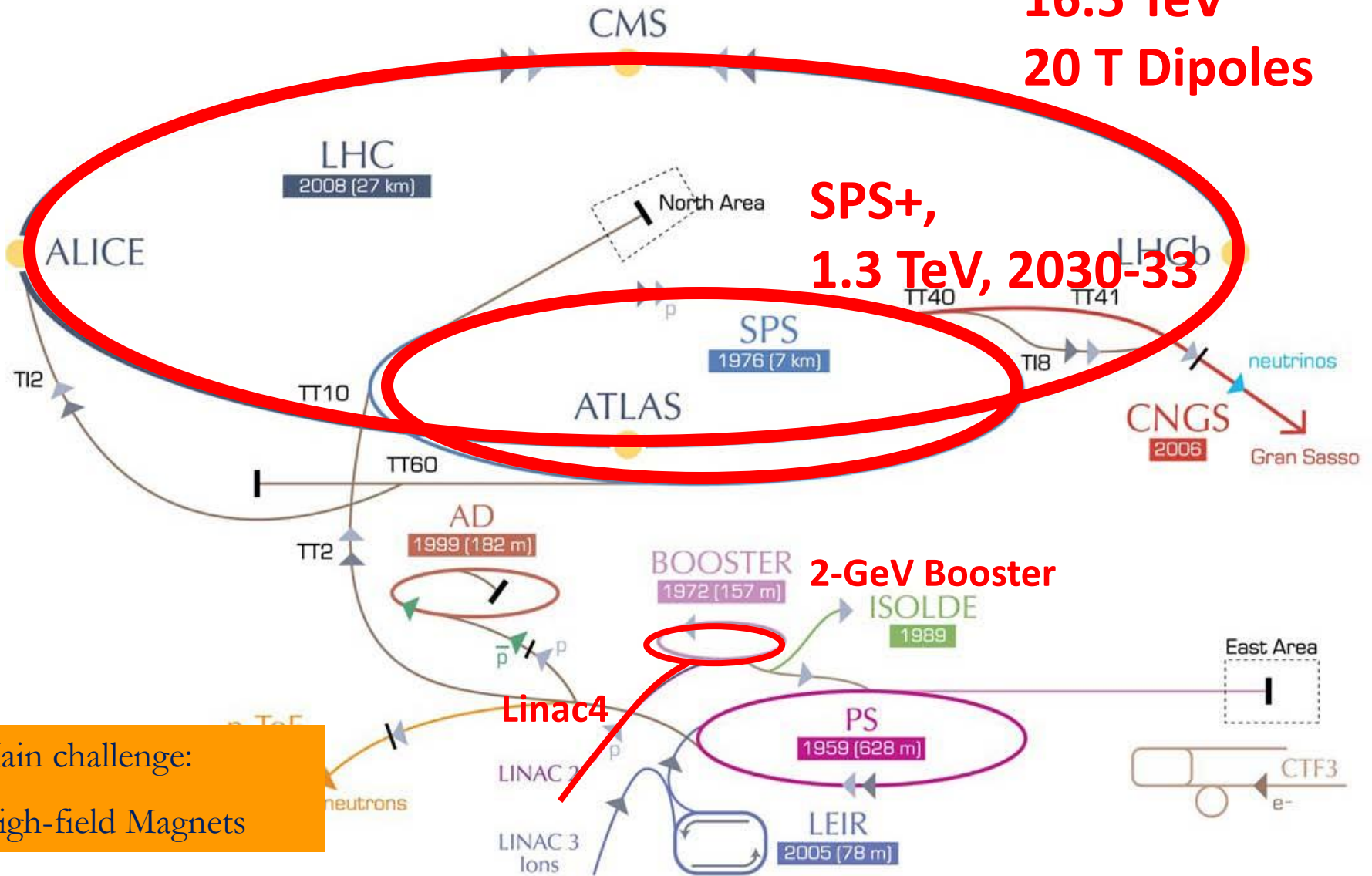

Main challenge:  
High-field Magnets

# CEPC+SppC

- For about 8 years, we have been talking about “What can be done after BEPCII in China”
- Thanks to the discovery of the low mass Higgs boson, and stimulated by ideas of Circular Higgs Factories in the world, CEPC+SppC configuration was proposed in Sep. 2012
- Circular Higgs factory (phase I) + super pp collider (phase II) in the same tunnel

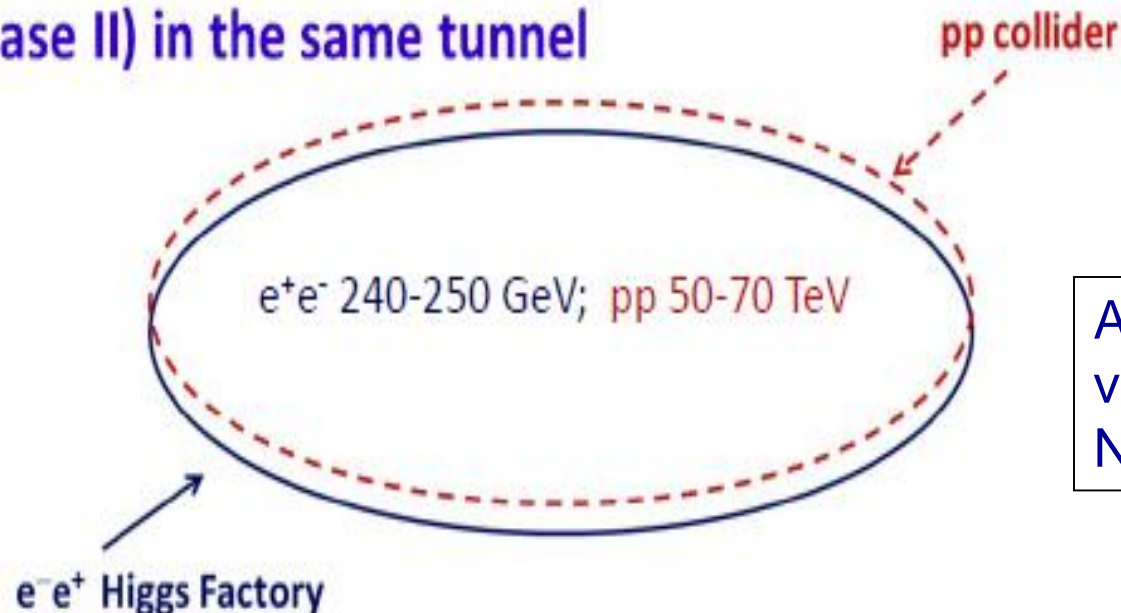

Yifang Wang  
Feb. 2014

A 50-70 km tunnel is  
very affordable in China  
NOW

# Site

- Preliminary selected: Qinhuangdao (秦皇岛)
- Strong support by the local government

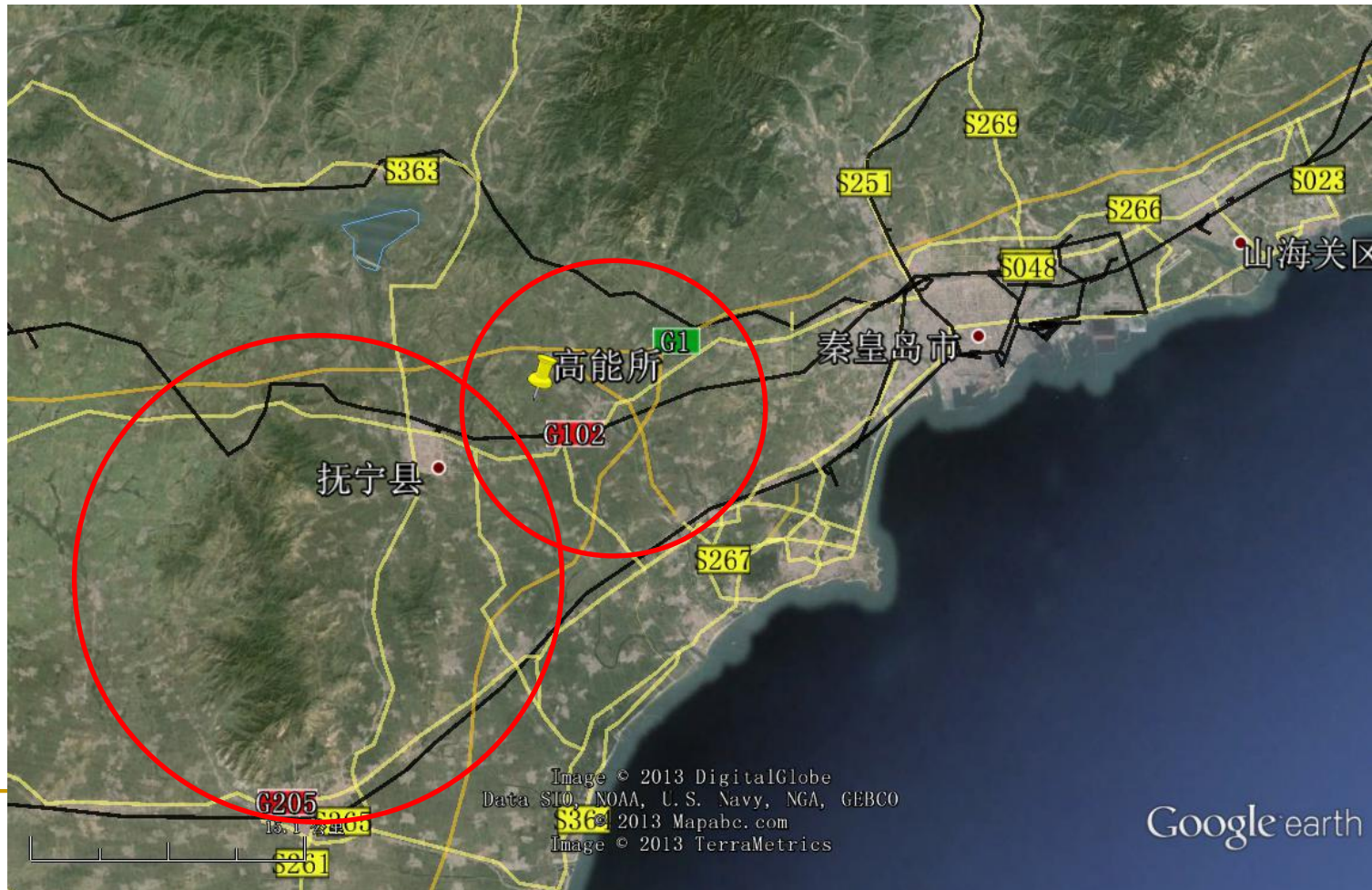

# CEPC+SppC Current Design

## CEPC Basic Parameters:

- Collision energy ~240 - 250 GeV
- Synchrotron radiation power ~50 MW
- 50/70 km in circumference

## SppC Basic Parameters:

- Collision energy ~50 - 70 TeV
- 50/70 km in circumference
- Needs  $B_{\max} \sim 20\text{T}$

CEPC circumference determined later based on cost estimate.

---

# Muon Collider (?)

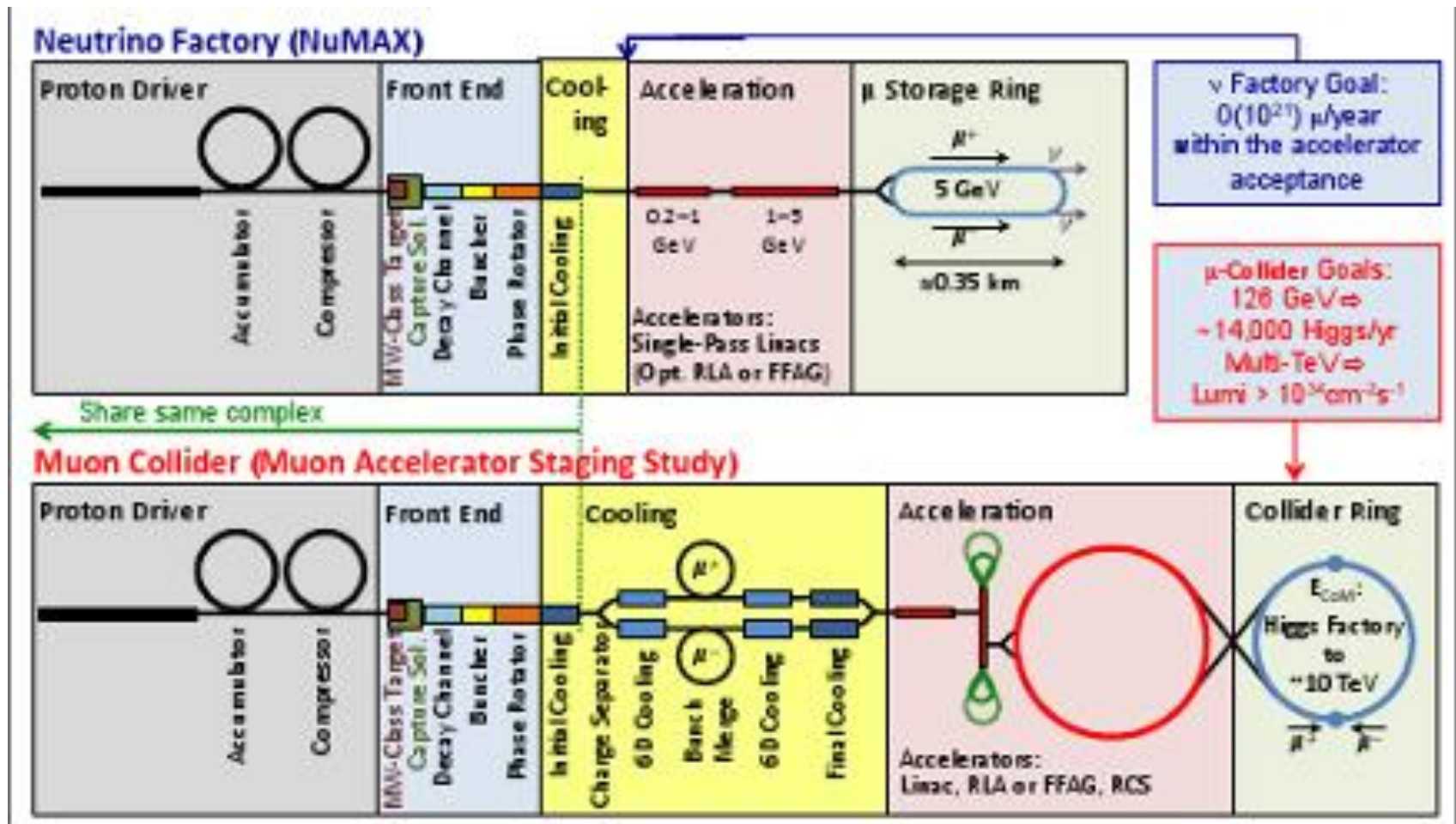

---

**BEYOND THE LHC**  
***LINEAR COLLIDERS***

---

# ILC (and the Compact Linear Collider CLIC)

## CLIC

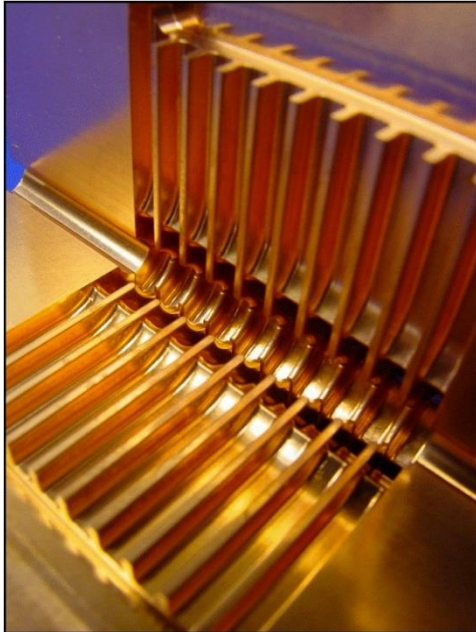

- 2-beam acceleration scheme at room temperature
- Gradient 100 MV/m
- $\sqrt{s}$  up to 3 TeV
- Physics + Detector studies for 350 GeV - 3 TeV

## Linear $e^+e^-$ colliders

Luminosities: few  $10^{34} \text{ cm}^{-2}\text{s}^{-1}$

## ILC



- Superconducting RF cavities (like XFEL)
- Gradient 32 MV/m
- $\sqrt{s} \leq 500 \text{ GeV}$  (1 TeV upgrade option)
- Focus on  $\leq 500 \text{ GeV}$ , physics studies also for 1 TeV

# The International Linear Collider

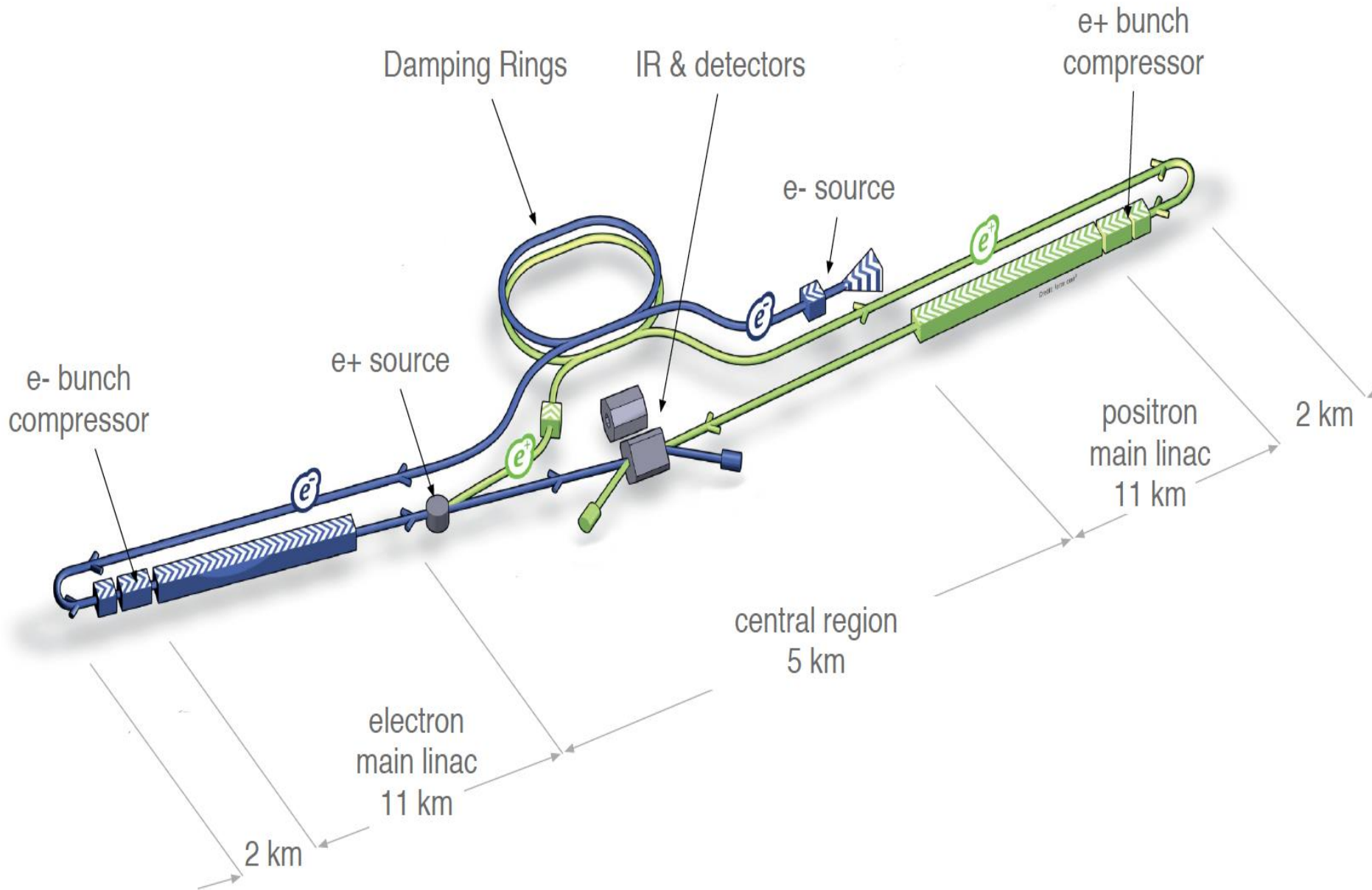



shield wall removed

# CLIC Implementation

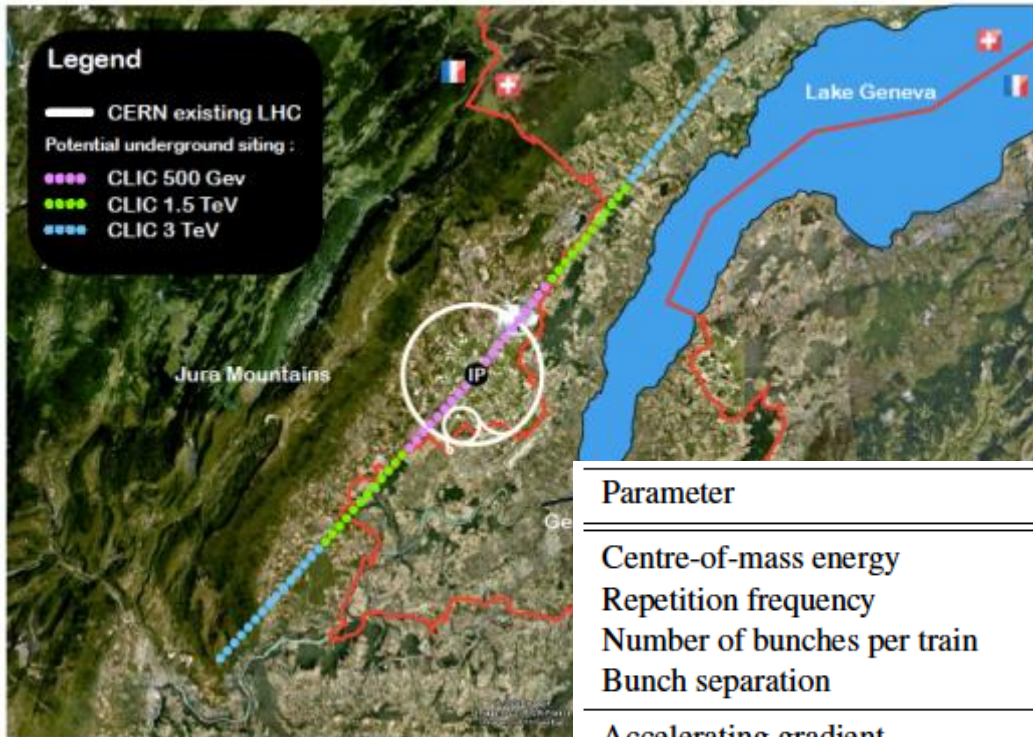

← Possible lay-out near CERN

↓ CLIC parameters

Parameter	Symbol	Unit			
Centre-of-mass energy	$\sqrt{s}$	GeV	500	1500	3000
Repetition frequency	$f_{rep}$	Hz	50	50	50
Number of bunches per train	$n_b$		312	312	312
Bunch separation	$\Delta_t$	ns	0.5	0.5	0.5
Accelerating gradient	$G$	MV/m	100	100	100
Total luminosity	$\mathcal{L}$	$10^{34} \text{ cm}^{-2} \text{ s}^{-1}$	1.3	3.7	5.9
Luminosity above 99% of $\sqrt{s}$	$\mathcal{L}_{0.01}$	$10^{34} \text{ cm}^{-2} \text{ s}^{-1}$	0.7	1.4	2
Main tunnel length		km	11.4	27.2	48.3
Charge per bunch	$N$	$10^9$	3.7	3.7	3.7
Bunch length	$\sigma_z$	$\mu\text{m}$	44	44	44
IP beam size	$\sigma_x/\sigma_y$	nm	100/2.6	$\approx 60/1.5$	$\approx 40/1$
Normalised emittance (end of linac)	$\epsilon_x/\epsilon_y$	nm	—	660/20	660/20
Normalised emittance	$\epsilon_x/\epsilon_y$	nm	660/25	—	—
Estimated power consumption	$P_{wall}$	MW	235	364	589

Note: the design is currently being re-optimised, e.g. to include 350 GeV as the first stage

# Plasma Accelerators

RF Cavity



1 m => 100 MeV Gain  
Electric field < 100 MV/m

Plasma Cavity

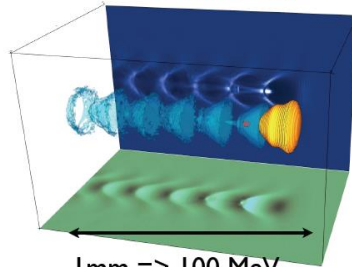

1 mm => 100 MeV  
Electric field > 100 GV/m

V. Malka et al., Science **298**, 1596 (2002)

## Plasma accelerators:

Transform transverse fields into longitudinal fields.

Significantly higher accelerating gradients than conventional RF.

e.g. AWAKE at CERN

Demonstration experiment to verify novel technique of p-driven plasma wakefield acceleration

Laser driven

e- driven

p driven

Dielectric wakefields

# The Sub-Fermi Scale (2015-2050)?

