



# Observations and Diagnostics in High Brightness Beams

A. Cianchi  
University of Rome "Tor Vergata"  
and INFN

- Brightness and its meaning
- Fundamental parameters
- Transverse and longitudinal measurements
- Intercepting and non intercepting diagnostics

- C. Lejeune and J. Aubert, “Emittance and Brightness, definitions and measurements”, *Adv. Electron. Electron Phys., Suppl. A* **13**, 159 (1980).
- A. Wu Chao, M. Tigner “Handbook of Accelerator Physics and Engineering” *World Scientific*, pag 255
- C. A. Brau “What Brightness means” in *The Physics and Applications of High Brightness Electron Beam*, *World Scientific*, pag 20
- M. Reiser, “Theory and design of charged particle beams”, *Wiley-VCH*, pag 61
- Shyh-Yuan Lee, “Accelerator Physics”, *World Scientific*, pag 419
- J. Clarke “The Science and Technology of Undulators and Wiggles” *Oxford Science Publications*, pag 73

- Several authors give different definitions
- Brilliance is sometimes used, especially in Europe, instead of brightness
- There is also confusion because the same words apply both to particle beams and photon beams
- The best way is to look to units, which should be unambiguous

# Definitions of Brightness

$$B = \frac{dI}{dSd\Omega}$$

For particle distribution whose boundary in 4D trace space is defined by an hyperellipsoid

$$\bar{B} = \frac{2I}{\pi^2 \varepsilon_x \varepsilon_y}$$

[A/(m-rad)<sup>2</sup>]

$$\bar{B}_n = \frac{2I}{\pi^2 \varepsilon_{nx} \varepsilon_{ny}}$$

**Normalized Brightness**

From diagnostics point of view what does it mean high brightness?

- High brightness can be achieved with small emittance, high current or both
- Longitudinal and transverse parameters must be measured
- High charge and small emittance -> high power density beam
- Low charge, very short bunch length
- We focus our attention on linac or transfer line where it is possible to use intercepting diagnostic

$$B = \frac{d^4 N}{dt d\Omega dS d\lambda / \lambda} \quad \text{Photons/ (s mm}^2 \text{ mrad}^2 \text{ 0.1\% of bandwidth)}$$

H. Wiedeman uses the name “spectral brightness” for photons

Report of the Working Group on Synchrotron Radiation Nomenclature – brightness, spectral brightness or brilliance?

The conclusion reached is that the term spectral brightness best describes this quantity. Brightness maintains the generally accepted concept of intensity per unit source size and divergence, while the adjective spectral conveys the scientific importance of the number of photons in a given bandwidth, particularly for experiments such as inelastic and/or nuclear resonant scattering.

J. Synchrotron Rad. (2005). 12, 385

- The most important parameter is the emittance
- To obtain high brightness beam it is of paramount importance to keep emittance growth under control
- Different methods apply for beams with or without space charge contribution
- Mainly the space charge is relevant at the exit of the RF GUN (few MeV)



# Importance of RMS emittance

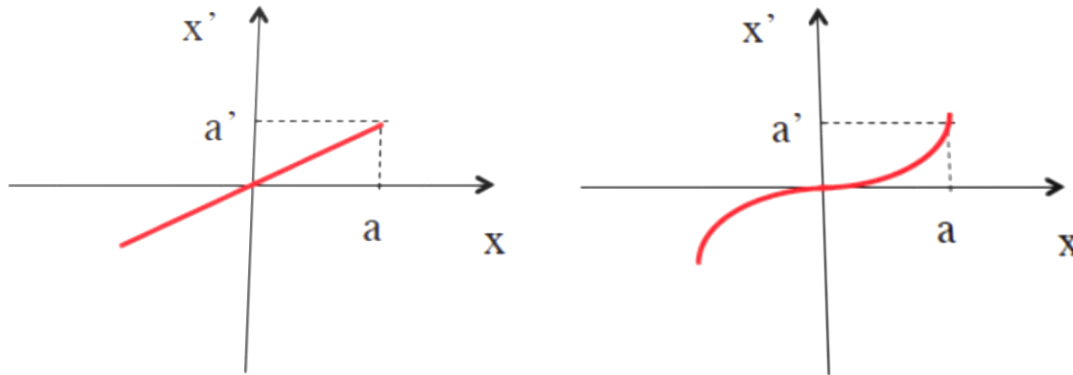

$$x' = Cx^n$$

$$\varepsilon_{rms} = C \sqrt{\langle x^2 \rangle \langle x^{2n} \rangle - \langle x^{n+1} \rangle^2} \quad \begin{cases} n = 1 \Rightarrow \varepsilon_{rms} = 0 \\ n > 1 \Rightarrow \varepsilon_{rms} \neq 0 \end{cases}$$

Even when the phase-space area is zero, if the distribution lies on a curved line its rms emittance is not zero.

RMS emittance is not an invariant for Hamiltonian with non linear terms.

# Geometrical vs Normalized

$$\varepsilon_n^2 = \langle x^2 \rangle \langle \beta^2 \gamma^2 x'^2 \rangle - \langle x \beta \gamma x' \rangle^2$$

$$\sigma_E^2 = \frac{\langle \beta^2 \gamma^2 \rangle - \langle \beta \gamma \rangle^2}{\langle \gamma \rangle^2}$$

$$\varepsilon_n^2 = \langle \gamma \rangle^2 \sigma_\varepsilon^2 \langle x^2 \rangle \langle x'^2 \rangle + \langle \beta \gamma \rangle^2 \left( \langle x^2 \rangle \langle x'^2 \rangle - \langle x x' \rangle^2 \right)$$

M. Migliorati et al, Physical Review Special Topics, Accelerators and Beams 16, 011302 (2013)

K. Floettmann, PRSTAB, 6, 034202 (2003)

$$\varepsilon_n^2 = \langle \gamma \rangle^2 (\sigma_\varepsilon^2 \sigma_x^2 \sigma_{x'}^2 + \varepsilon^2)$$

$$\sigma_x(s) \approx \sigma_{x'} s$$

$$\varepsilon_n^2 = \langle \gamma \rangle^2 (s^2 \sigma_\varepsilon^2 \sigma_{x'}^4 + \varepsilon^2)$$

- For the accelerator community the normalized emittance is one of the main parameter because is constant
- For plasma accelerated beams, due to the large energy spread and huge angular divergence, it is not true anymore

# Intercepting devices

- OTR monitors
  - High energy (>tens of MeV), high charge (>hundreds of pC)
  - No saturation
  - Resolution limit closed to optical diffraction limit
  - Surface effect

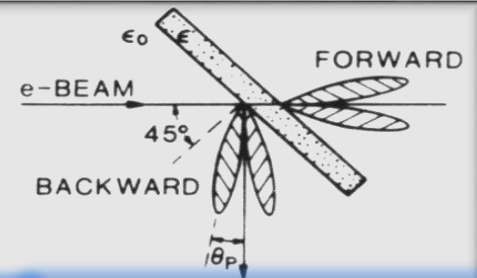

- Scintillator (like YAG:CE)
  - Large number of photons
  - Resolution limited to grain dimension (few microns)
  - Saturation depending of the doping level
  - Bulk effect
  - Thin crystal to prevent blurring effect

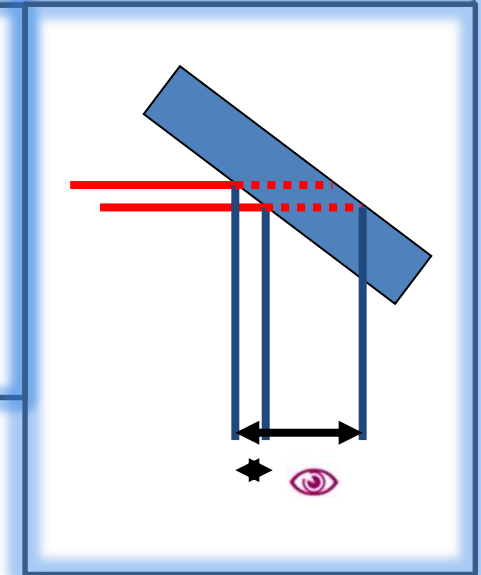

- Wire scanner
  - Multiple scattering reduced
  - Higher beam power
  - Multishot measurement
  - 1 D
  - Complex hardware installation

# Space charge regime

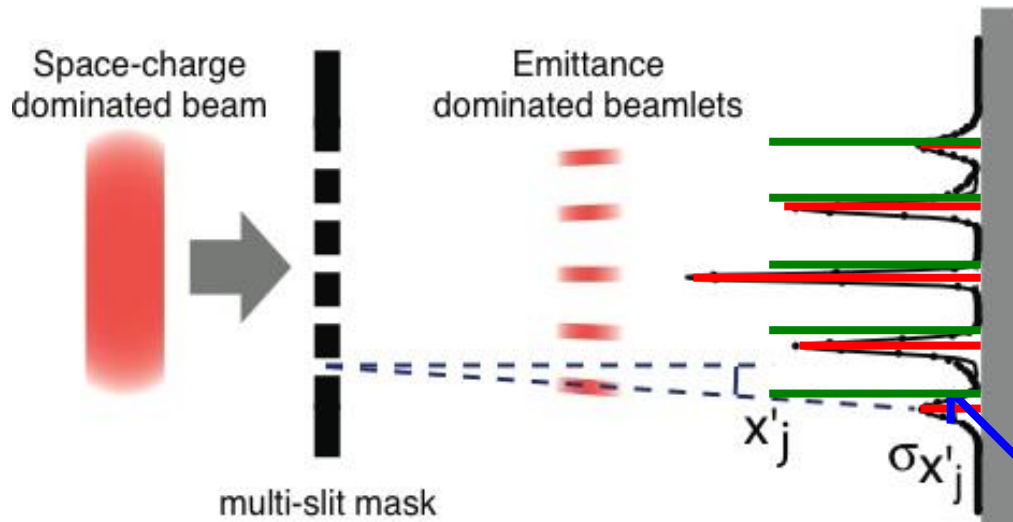

To measure the emittance for a space charge dominated beam the used technique is the well known 1-D pepper-pot

The emittance can be reconstructed from the second momentum of the distribution

$$\varepsilon = \sqrt{\langle x^2 \rangle \langle x'^2 \rangle - \langle xx' \rangle^2}$$

C. Lejeune and J. Aubert, Adv. Electron. Electron Phys. Suppl. A **13**, 159 (1980)

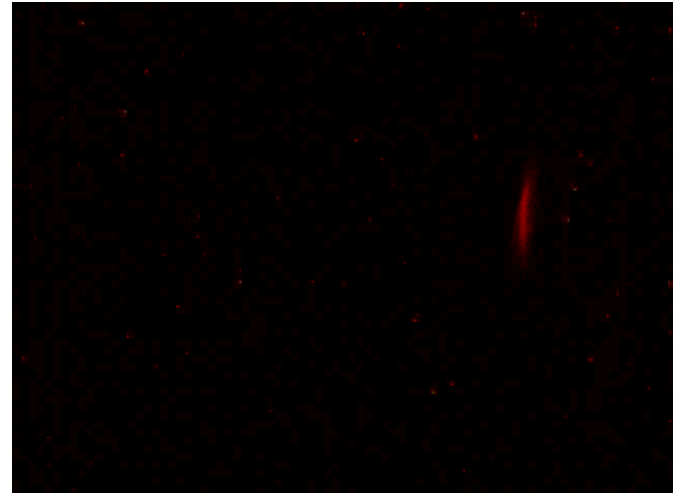
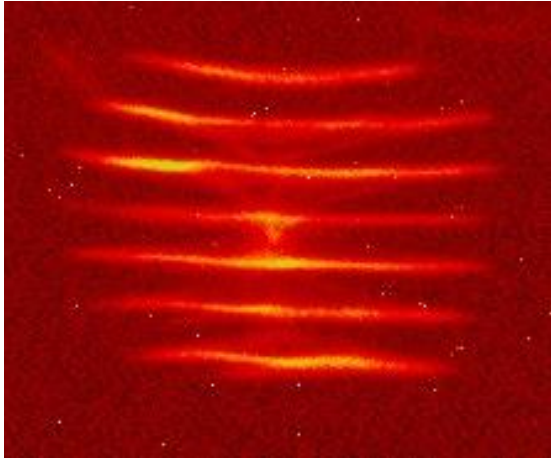

- The beamlets must be emittance dominated

$$\sigma_x'' = \frac{\varepsilon_n^2}{\gamma^2 \sigma_x^3} + \frac{I}{\gamma^3 I_0 (\sigma_x + \sigma_y)}$$

*Martin Reiser, Theory and Design of Charged Particle Beams (Wiley, New York, 1994)*

- Assuming a round beam

$$R_0 = \frac{I \sigma_0^2}{2 \mathcal{I}_0 \varepsilon_n^2} \quad \sigma_x = \frac{d}{\sqrt{12}}$$

- $d$  must be chosen to obtain  $R_0 \ll 1$ , in order to have a emittance dominated beam

- The contribution of the slit width to the size of the beamlet profile should be negligible
- The material thickness (usually tungsten) must be long enough to stop or heavily scatter beam at large angle (critical issue at high energy)
- The angular acceptance of the slit cannot be smaller of the expected angular divergence of the beam

$$\sigma = \sqrt{(L \cdot \sigma')^2 + \left(\frac{d^2}{12}\right)}$$

$$L \gg \frac{d}{\sigma' \cdot \sqrt{12}}$$

$$l < \frac{d}{2\sigma'}$$



# Phase space mapping

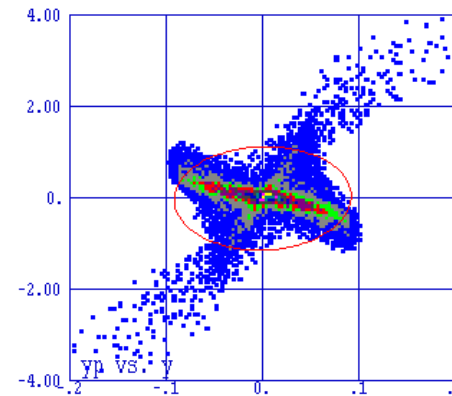
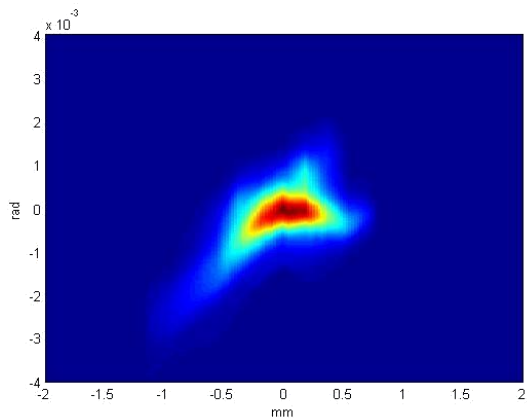
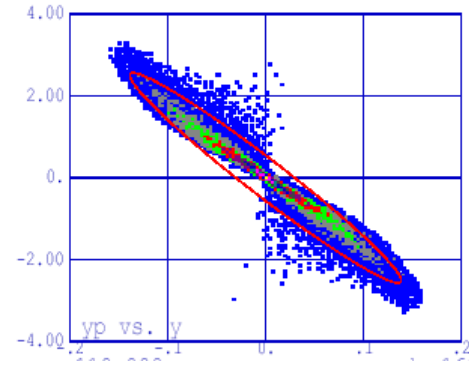
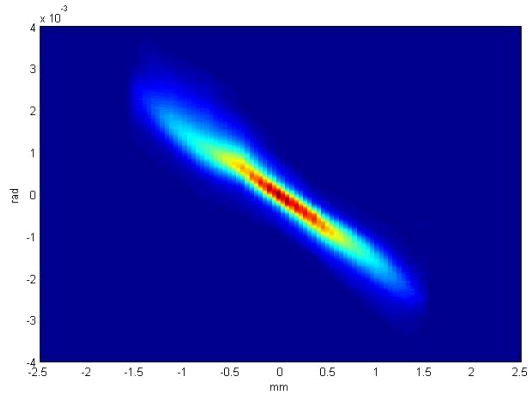

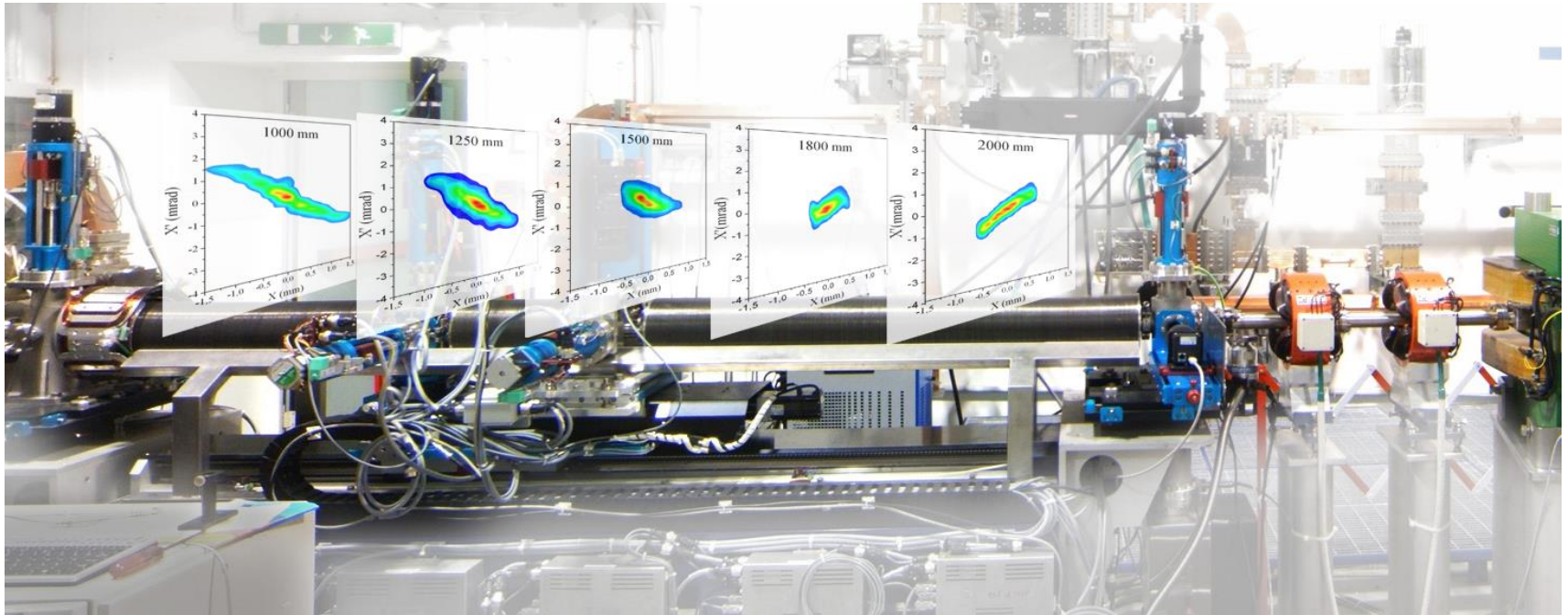

*A. Cianchi et al., "High brightness electron beam emittance evolution measurements in an rf photoinjector", Physical Review Special Topics Accelerator and Beams 11, 032801,2008*

- The most used techniques for emittance measurements are quadrupole scan and multiple monitors

$$\gamma x^2 + 2\alpha x x' + \beta x'^2 = \varepsilon = \gamma_0 x_0^2 + 2\alpha_0 x_0 x'_0 + \beta_0 x_0'^2$$

$$M(s_1 s_2) = \begin{pmatrix} C & S \\ C' & S' \end{pmatrix} \begin{pmatrix} \beta \\ \alpha \\ \gamma \end{pmatrix} = \begin{pmatrix} C^2 & -2SC & S^2 \\ -CC' & S'C + SC' & -SS' \\ C'^2 & -2S'C' & S'^2 \end{pmatrix} \begin{pmatrix} \beta_0 \\ \alpha_0 \\ \gamma_0 \end{pmatrix}$$

$$\sigma = \begin{pmatrix} \sigma_{11} & \sigma_{12} \\ \sigma_{12} & \sigma_{22} \end{pmatrix} = \varepsilon \begin{pmatrix} \beta & -\alpha \\ -\alpha & \gamma \end{pmatrix}$$

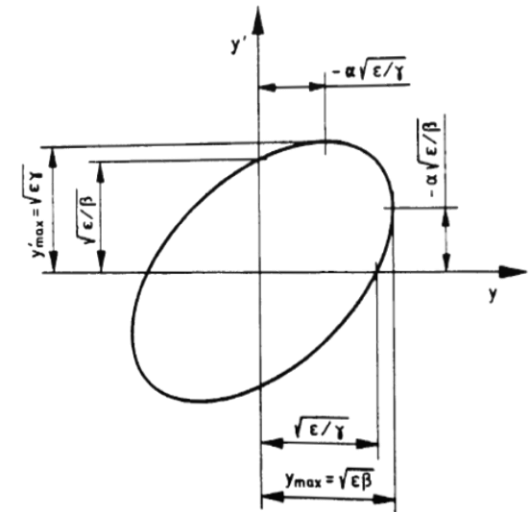

$$\sigma_{11}x^2 + 2\sigma_{12}xx' + \sigma_{22}x'^2 = 1$$

$$\sigma_1 = M\sigma_0M^T$$

$$\sigma_{i,11} = C_i^2 \sigma_{11} + 2S_i C_i \sigma_{12} + S_i^2 \sigma_{22}$$

- There are 3 unknown quantities
- $\sigma_{i,11}$  is the RMS beam size
- $C_i$  and  $S_i$  are the element of the transport matrix
- We need 3 measurements in 3 different positions to evaluate the emittance

# Example: FLASH@DESY

- M. Minty, F. Zimmermann, "Measurement and control of charged particle beams", Springer (2003)
- DESY-Technical Note 03-03 , 2003 (21 pages) Monte Carlo simulation of emittance measurements at TTF2 P. Castro

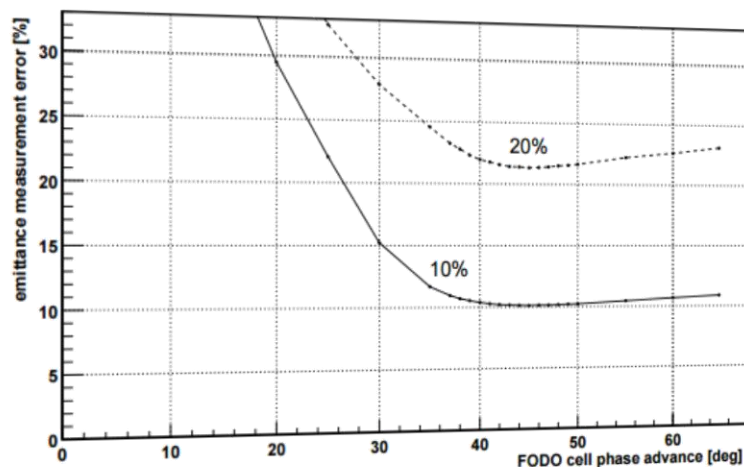
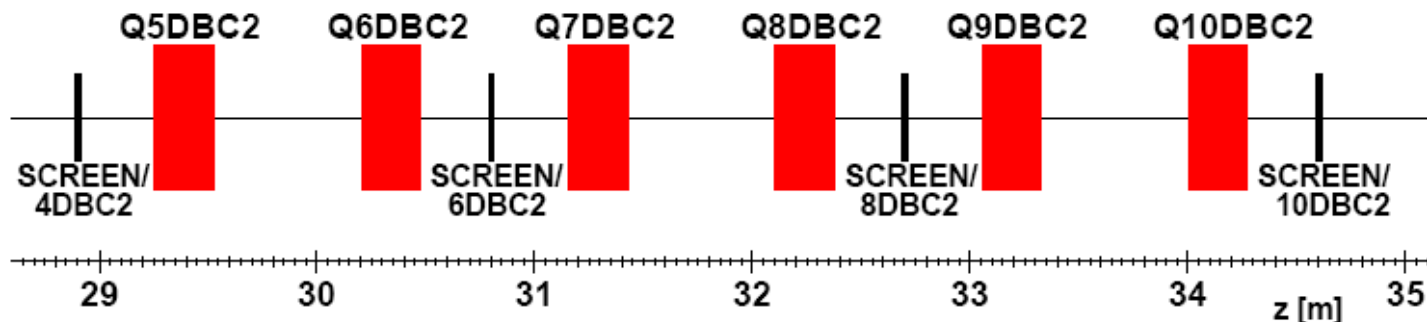

# Quadrupole scan

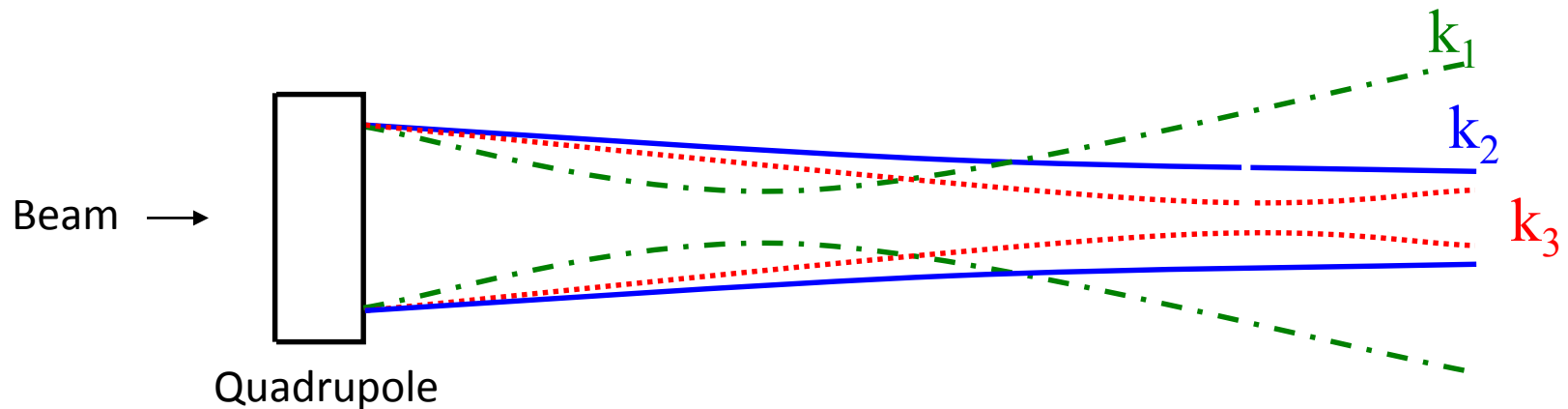

$$\sigma_{11} = C^2(k)\sigma_{11} + 2C(k)S(k)\sigma_{12} + S^2(k)\sigma_{22}$$

- It is possible to measure in the same position changing the optical functions
- The main difference respect to the multi screen measurements is in the beam trajectory control and in the number of measurements

- Usually the largest error is in the determination of the RMS beam size (Mini Workshop on "Characterization of High Brightness Beams", *Desy Zeuthen 2008*, <https://indico.desy.de/conferenceDisplay.py?confId=806>)
- Systematic error comes from the determination of the quadrupole strength, mainly for hysteresis. So a cycling procedure is required for accurate measurements
- Thin lens model is not adequate
- Energy
- Large energy spread can give chromatic effect
- Assumption: transverse phase space distribution fills an ellipse
- F. Loehl et al. "Physical Review Special Topics - Accelerators and Beams" **9, 092802 (2006)**



# Phase space reconstruction

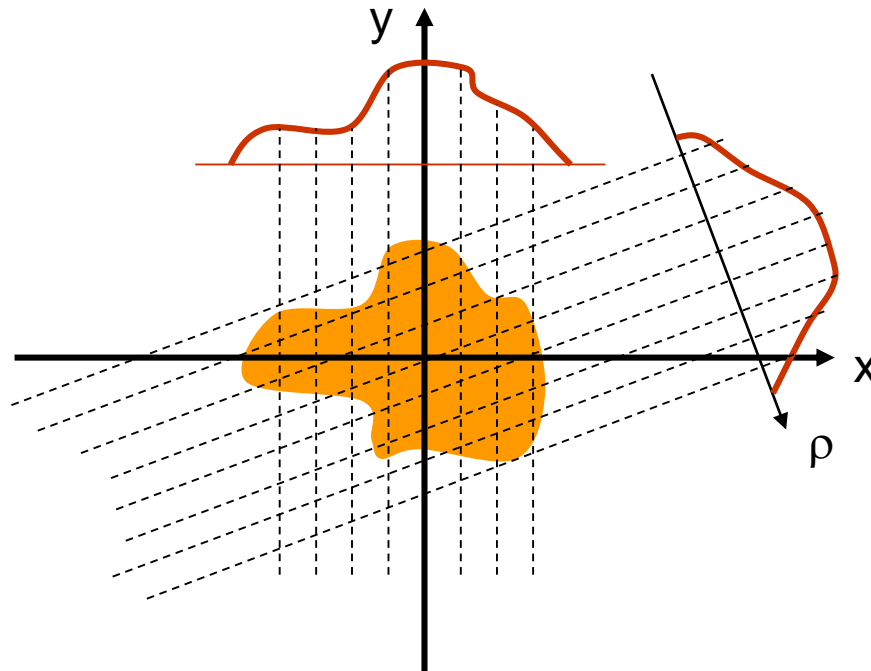

- Tomography is related to the Radon theorem: a  $n$ -dimensional object can be reconstructed from a sufficient number of projection in  $(n-1)$  dimensional space

- High charge or high repetition rate machines
- Small beam dimension (between 50  $\mu\text{m}$  down to tens of nm)
- All the intercepting devices are damaged or destroyed from these kind of beams
- No wire scanners, no OTR screens, no scintillators
- There are good candidates for longitudinal diagnostic
- It is difficult to replace intercepting devices for transverse dimensions
- There are a lot of ideas in testing

# Laser Wire

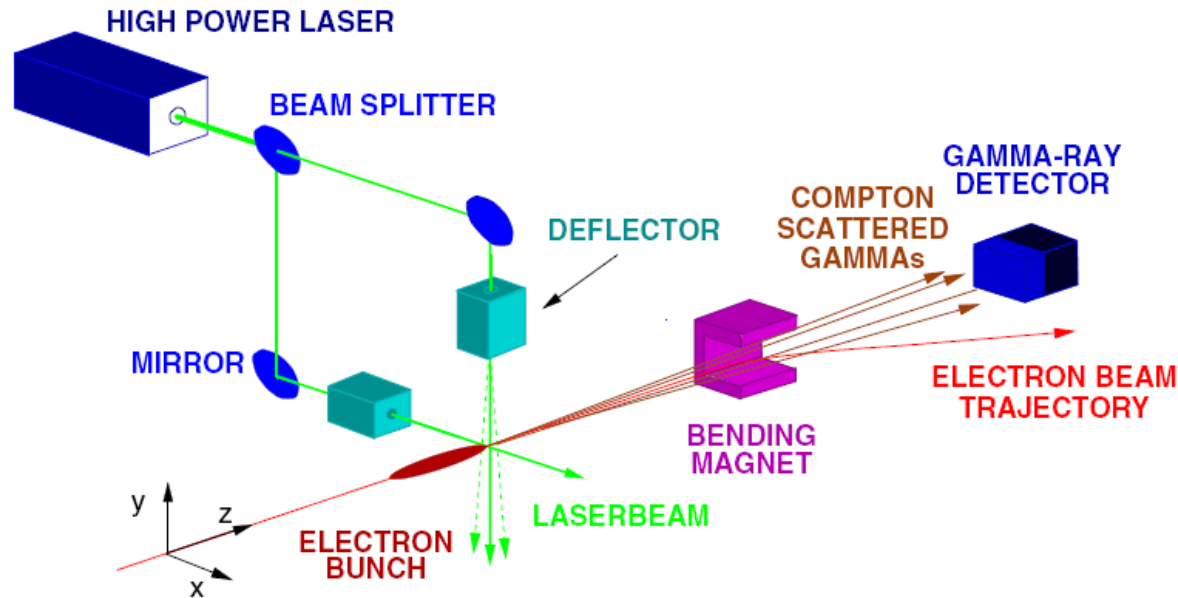

- Not intercepting device
- Multi shot measurement (bunch to bunch position jitter, laser pointing jitter, uncertainty in the laser light distribution at IP)
- Setup non easy
- Resolution limited from the laser wavelength
- Several effects to take into account
- I. Agapov, G. A. Blair, M. Woodley, "Beam emittance measurement with laser wire scanners in the International Linear Collider beam delivery system", Physical review special topics- accelerators and beams 10, 112801 (2007)

# Rayleigh range

- Rayleigh range of the laser beam : distance between the focus and the point where the laser spot-size has diverged to  $\sqrt{2}$  of its minimum value

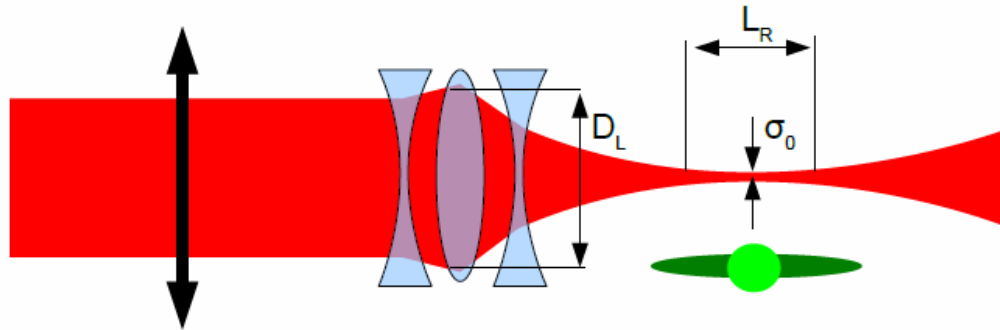

High resolution LW require

- High power, high quality lasers (mJ, ps)
- Complex focusing systems
- Precise scanning systems (as an alternative the beam can be moved around)
- The resolution of the laser wire scanners is limited by the minimum waist size
- A strongly focused laser beam will have a short waist length (Rayleigh length) and is not adapted for small beams with large aspect ratios
- Other limiting factors are laser stability, vibrations, x-ray detection

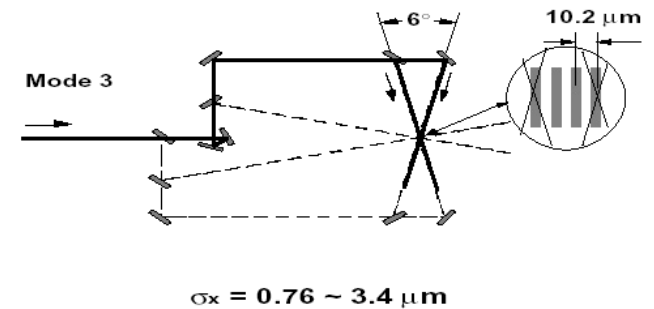
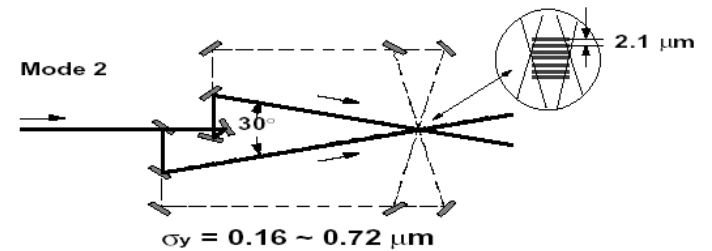
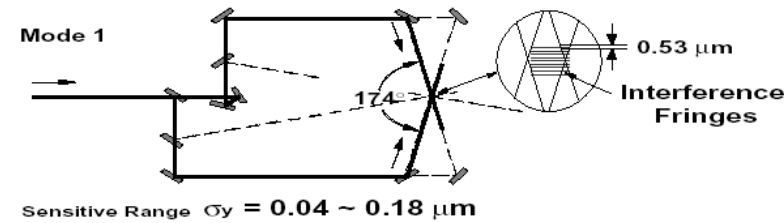
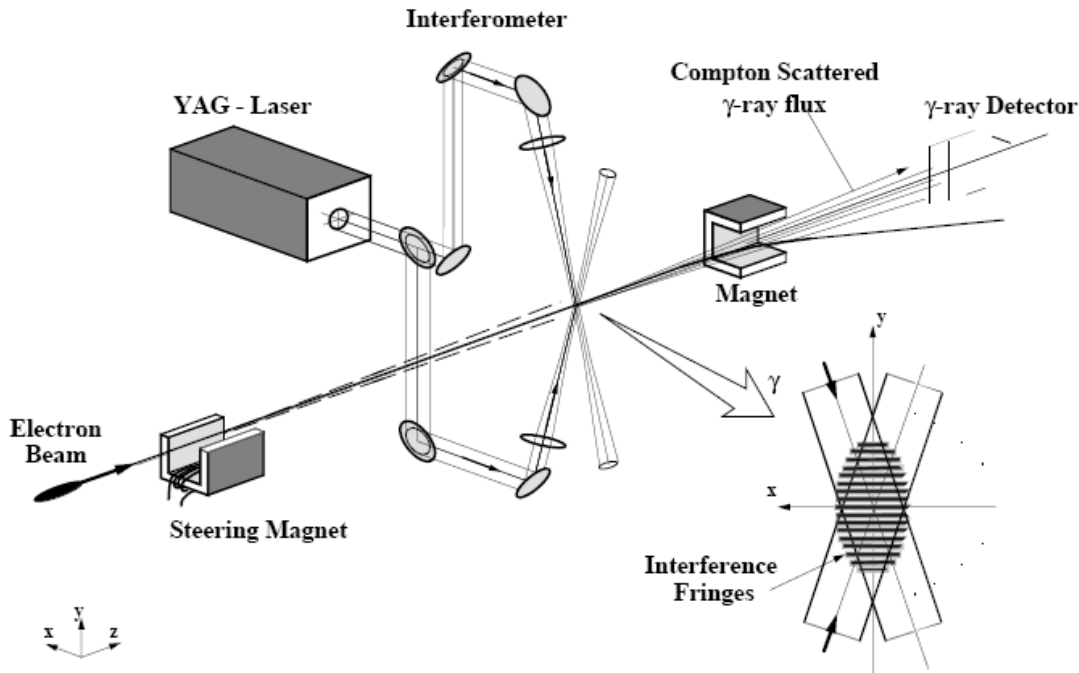

- Tsumoru Shintake, "Proposal of a nanometer beam size monitor for  $e^+e^-$  linear collider", Nuclear Instruments and methods in Physics Research A311 (1992) 453

# A little bit complicated

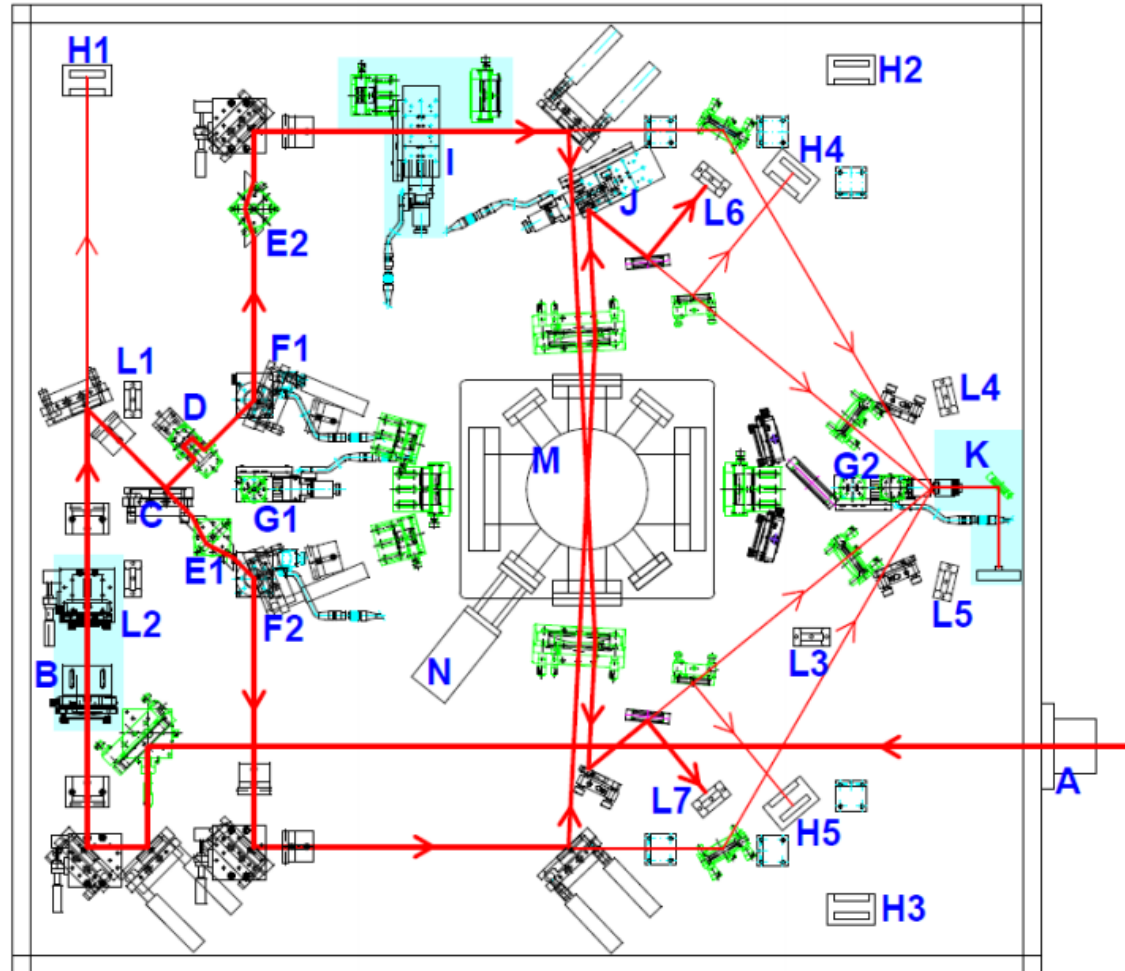

# Not intercepting multi shot

Steven J. Russell, Emittance measurements of the Sub-Picosecond Accelerator electron beam using beam position monitors, Review of Scientific Instruments 70, 2, February 1999

A. Jansson, "Noninvasive single-bunch matching and emittance monitor", PRSTA-AB 5, 072803 (2002)

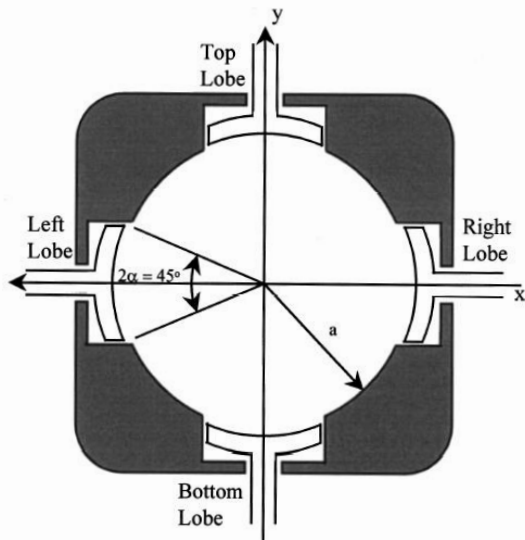

- Special and customized electrodes are needed in order to maximize the quadrupole component
- Very low signal to noise ratio, systematic error from beam position



- The charge goes into the hole without touching the screen
- The electromagnetic field of the moving charge interacts with the metallic screen
- No power is deposited on the screen
- The angular distribution of the emerging radiation is affected by the beam transverse size, the angular spread and the position inside the slit
  - M. Castellano 1997 Nucl. Instrum. Methods Phys. Res., Sect. A **394**, 275.
- Rectangular slit

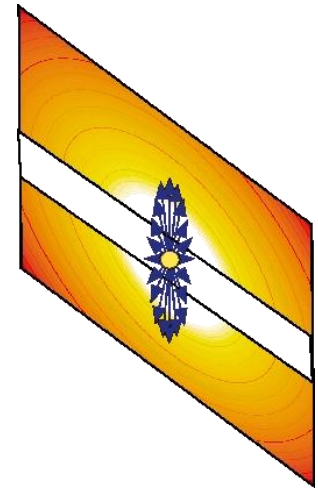

$$I \propto e^{-\frac{2\pi a}{\gamma\lambda}}$$

**P. Karataev et al.**, “*Beam-Size Measurement with Optical Diffraction Radiation at KEK Accelerator Test Facility*”, *Phys. Rev. Lett.* **93**, 244802 (2004)

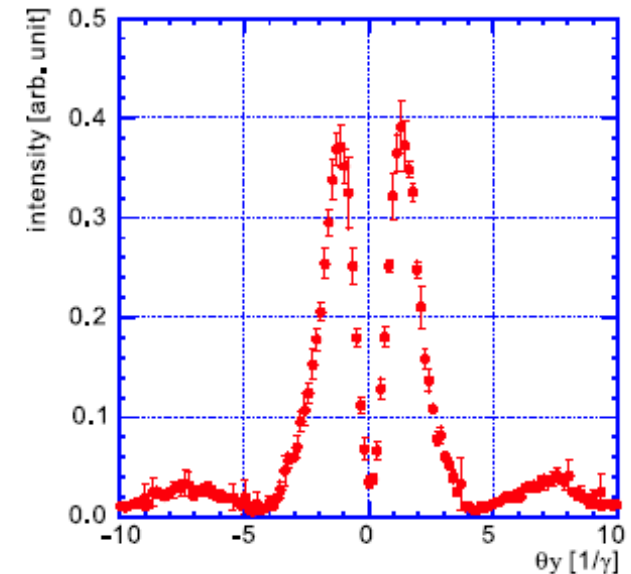

- **Weak signal vs strong background, coming mainly from Synchrotron Radiation**
- **Precise control of the beam position inside the slit needs a complementary diagnostics**

## Optical Diffraction Radiation Interference

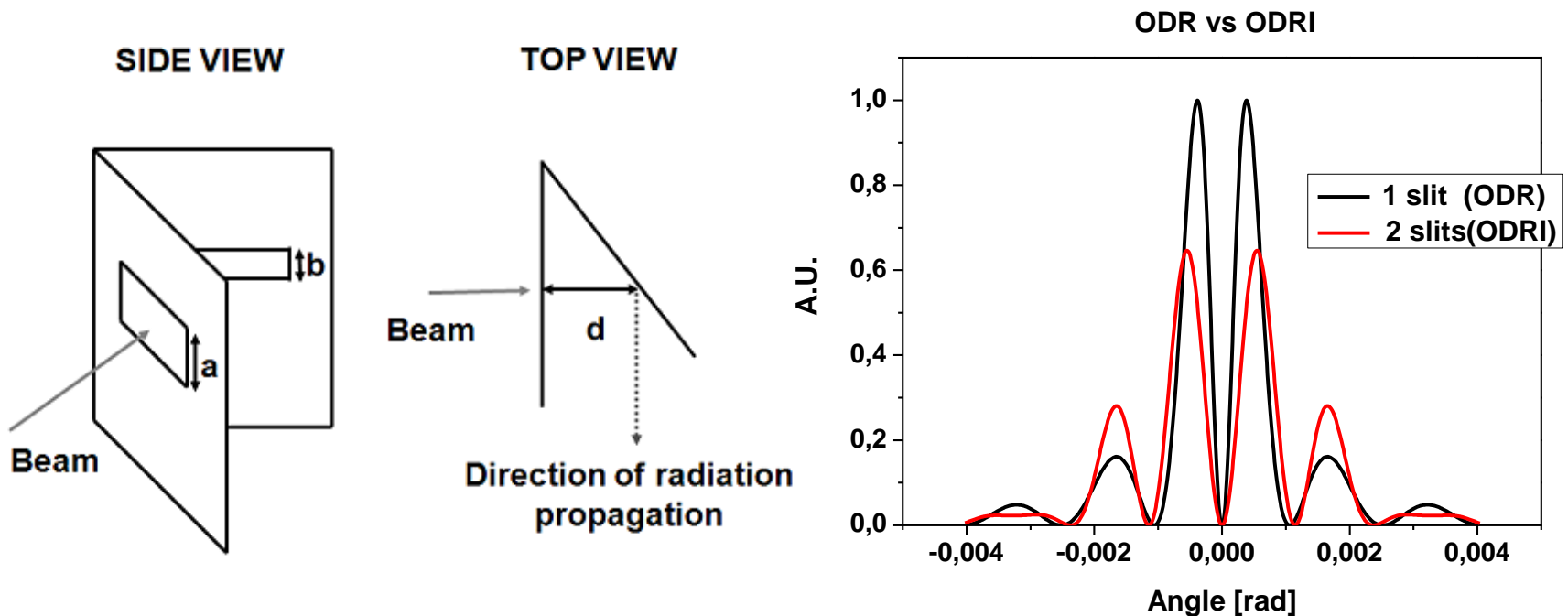

A. Cianchi et al. "Nonintercepting electron beam size monitor using optical diffraction radiation interference", PRSTAB 14, 102803

# ODRI emittance measurement

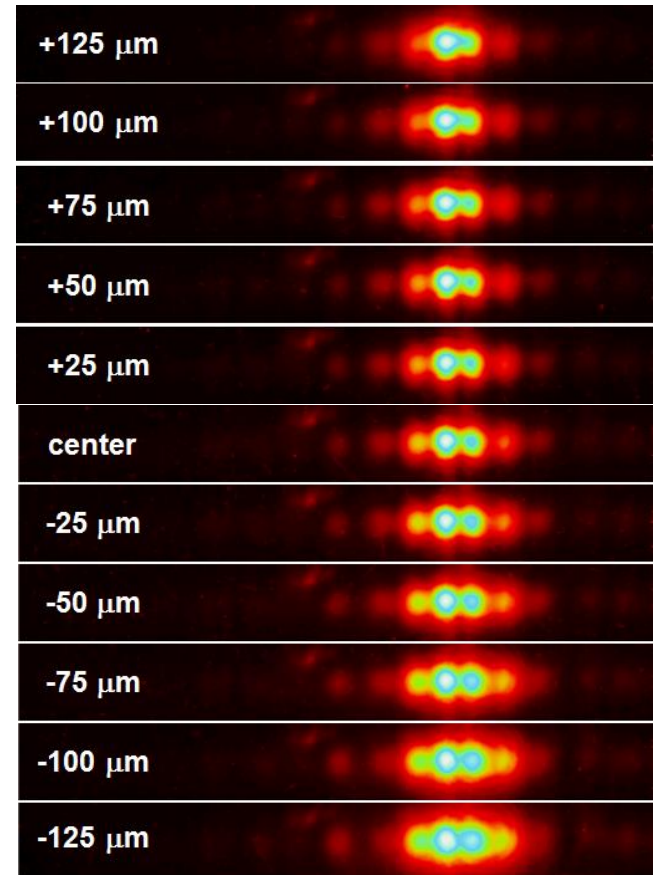
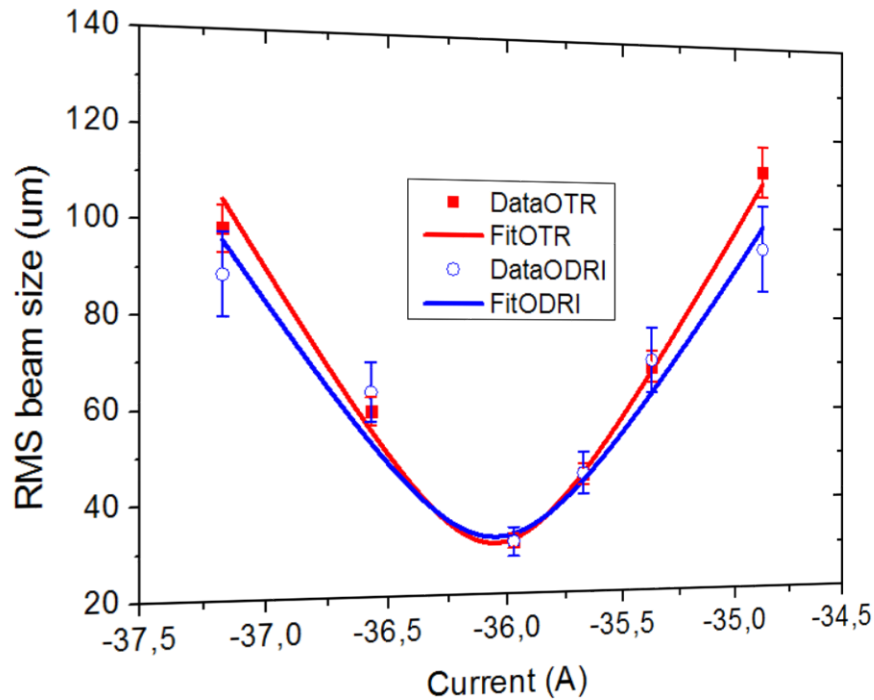

Cianchi, A., et al. "First non-intercepting emittance measurement by means of optical diffraction radiation interference." *New Journal of Physics* 16.11 (2014): 113029.

- Fundamental parameter for the brightness
- Bunch lengths can be on ps (uncompressed) or sub-ps time scale, down to fs scale!
- Several methods
  - Coherent radiations
  - RFD
  - EOS
  - Others?
- T. Watanabe et al, “*Overall comparison of subpicosecond electron beam diagnostics by the polychromator, the interferometer and the femtosecond streak camera*”, Nuclear Instruments and Methods in Physics Research A 480 (2002) 315–327

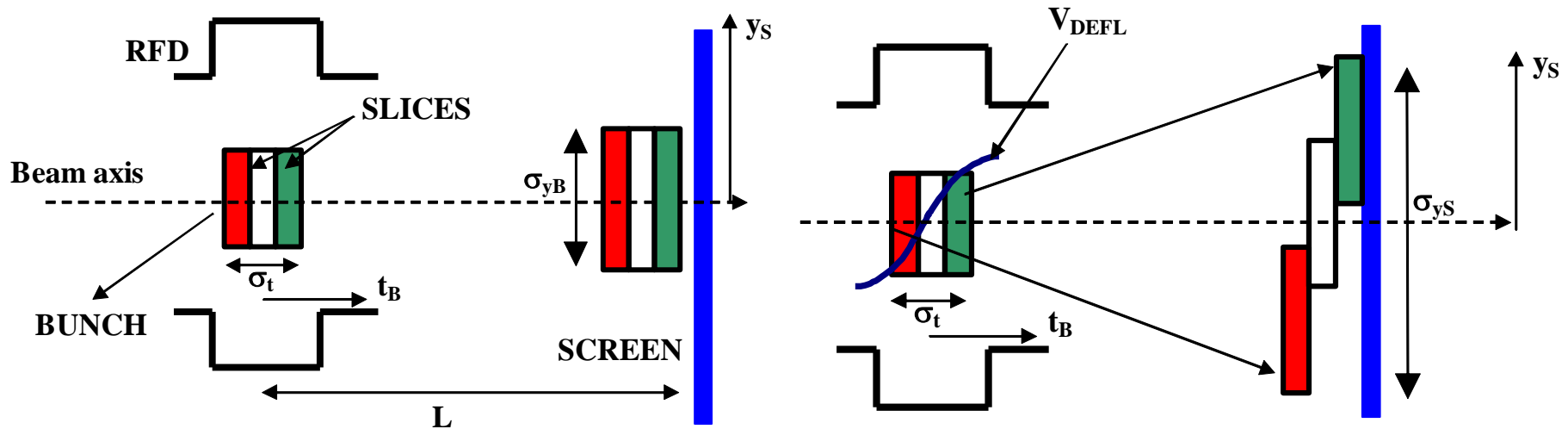

Paul Emma, Josef Frisch, Patrick Krejcik, A Transverse RF Deflecting Structure for Bunch Length and Phase Space Diagnostics, LCLS-TN-00-12

Christopher Behrens, Measurement and Control of the Longitudinal Phase Space at High-Gain Free-Electron Lasers , FEL 2011, Shanghai

# Longitudinal phase space

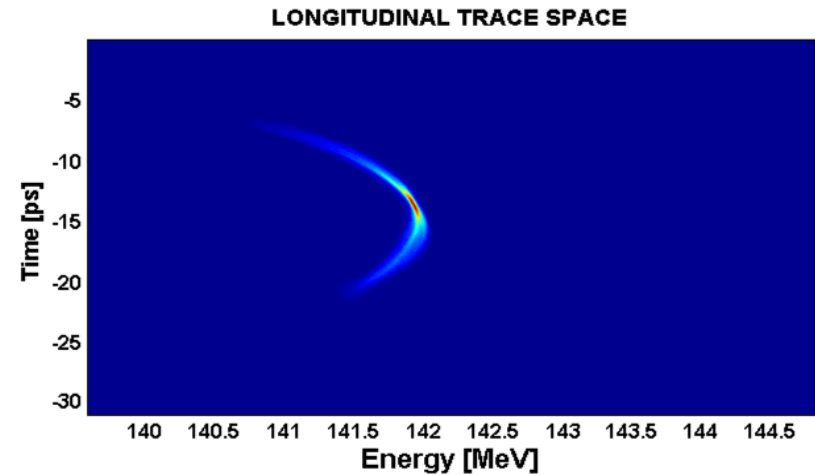
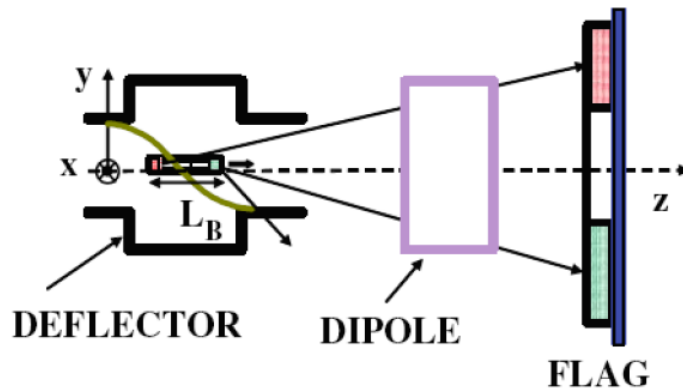

- Using together a RFD with a dispersive element such as a dipole
- Fast single shot measurement

- Self calibrating
- Easy to implement
- Single shot
- Resolution down to fs
- Intercepting device
- As energy increases some parameter must be increased:
  - Frequency
  - Voltage or length

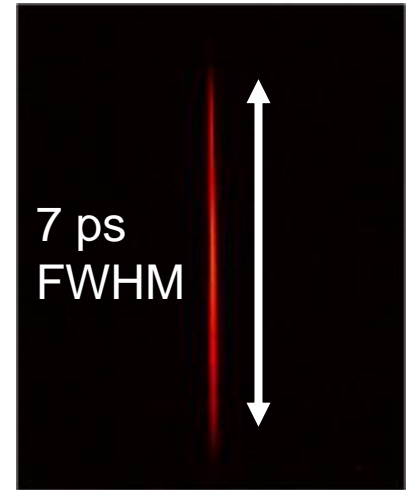



- Any kind of radiation can be coherent and usable for beam diagnostics
  - Transition radiation
  - Diffraction radiation
  - Synchrotron radiation
  - Undulator radiation
  - Smith-Purcell radiation
  - Cherenkov radiation

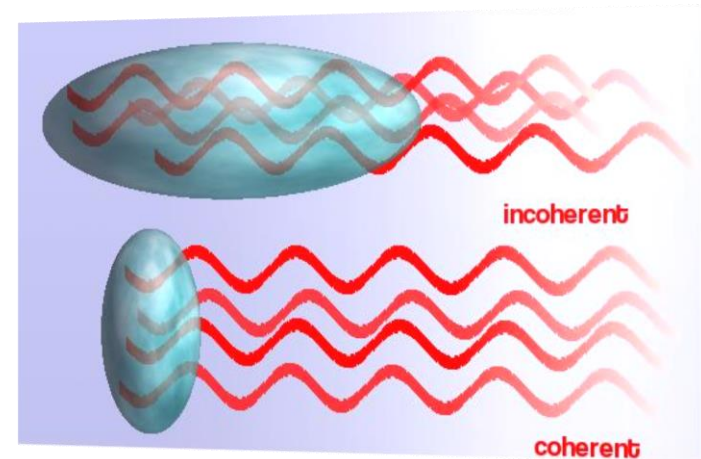

$$I_{\text{tot}}(\omega) = I_{\text{sp}}(\omega) [N + N^*(N-1) F(\omega)]$$

$$F(\omega) = \left| \int_{-\infty}^{\infty} dz \rho(z) e^{i(\omega/c)z} \right|^2 \quad \rho(z) = \frac{1}{\pi c} \int_0^{\infty} d\omega \sqrt{F(\omega)} \cos\left(\frac{\omega z}{c}\right)$$

- From the knowledge of the power spectrum is possible to retrieve the form factor
- The charge distribution is obtained from the form factor via Fourier transform
- The phase terms can be reconstructed with Kramers-Kronig analysis (see R. Lai, A.J. Sievers, NIM A **397** (1997) 221-231)

# Martin-Puplett Interferometer

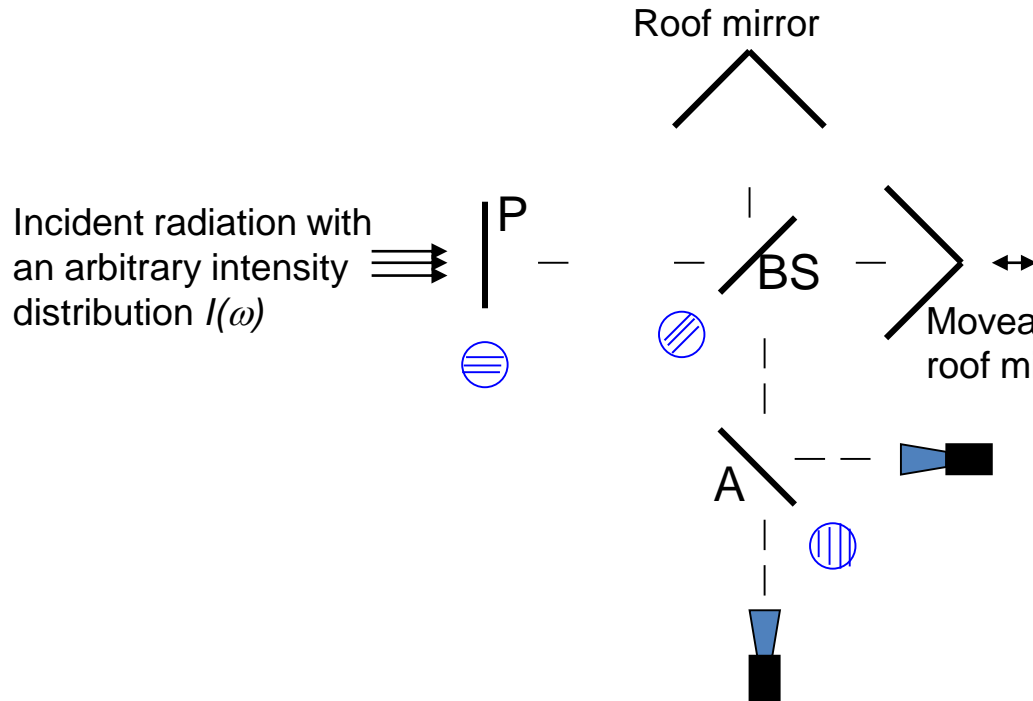

- Goly cells or Pyroelectric detector

$$I(\delta) \propto \int_{-\infty}^{\infty} |E(t) + E(t + \delta/c)|^2 dt$$

$$I(\omega) \propto \int_{-\infty}^{\infty} I(\delta) \cos\left(\frac{\omega\delta}{c}\right) d\delta$$

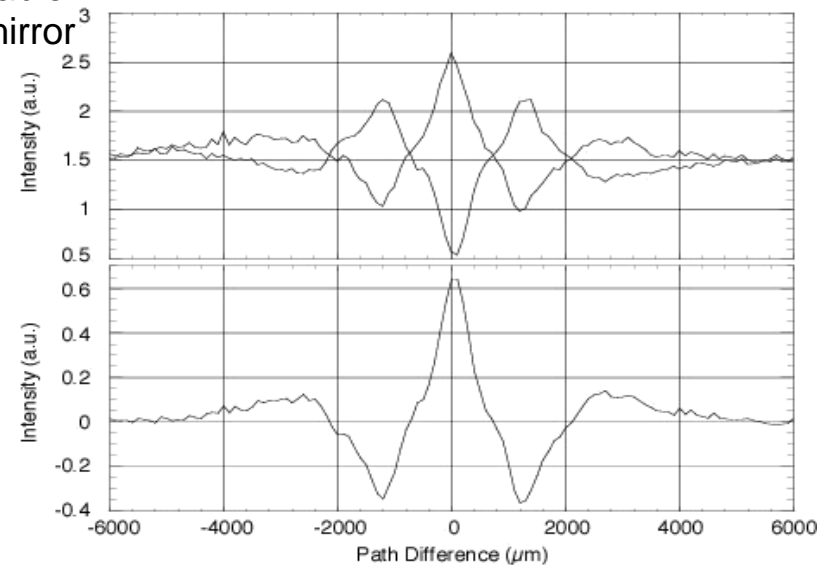

- Spectrum cuts at low and high frequencies can affect the beam reconstruction
  - Detectors
  - Windows
  - Transport line
  - Finite target size
- For this reason the approach is to test the power spectrum with the Fourier transform of a guess distribution
- Coherent synchrotron radiation or diffraction radiation can be generated by totally not intercepting devices and so they are eligible for high brightness beams diagnostic
- Multishots measurements. Single shot devices are still under developing

# Single shot CTR measurements I

- S. Wesch, B. Schmidt, C. Behrens, H. Delsim-Hashemi, P. Schmuser, A multi-channel THz and infrared spectrometer for femtosecond electron bunch diagnostics by single-shot spectroscopy of coherent radiation Nuclear Instruments and Methods in Physics Research A 665 (2011) 40–47

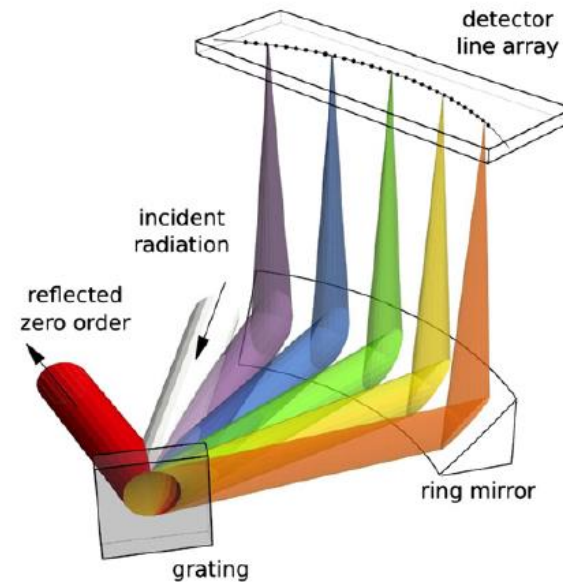
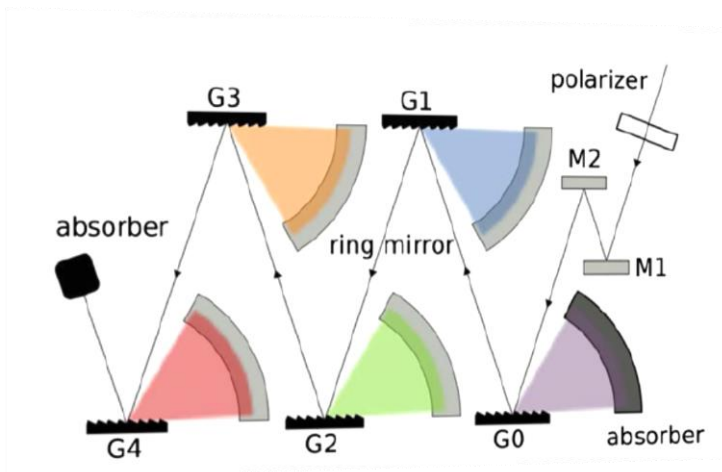

Pyro-electric line detector 30 channels @ room temperature no window, works in vacuum fast read out sensitivity

# Single shot CTR measurements II

- T. J. Maxwell et al. "Coherent-radiation spectroscopy of few-femtosecond electron bunches using a middle-infrared prism spectrometer." *Physical review letters* 111.18 (2013)

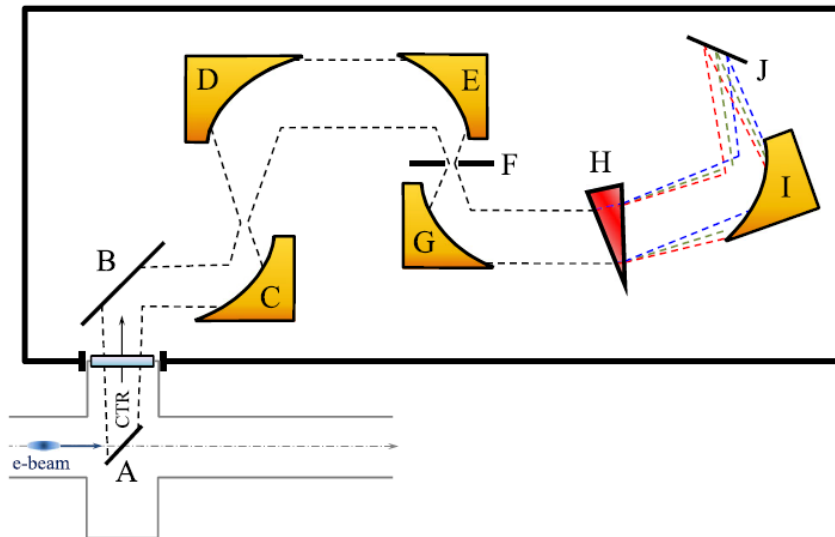

KRS-5 (thallium bromoiodide)  
prism based spectrometer  
developed

Images OTR from foil onto 128 lead  
zirconate titanate pyroelectric  
elements with 100  $\mu\text{m}$  spacing line  
array

Also double prism (ZnSe), S. Wunderlich et al., Proceedings of IBIC2014

- Totally non intercepting device and not disturbing device
- It is based on the change of the optical properties of a non linear crystal in the interaction with the Coulomb field of the moving charges
- Several schemes has been proposed and tested
- Very promising technique

- I.Wilke et al., “single-Shot electron beam bunch length measurements” PRL, v.88, 12(2002)
- G. Berden et al., “Electo-Optic Technique with improved time resolution for real time, non destructive, single shot measurements of femtosecond electron bunch profiles, PRL v93, 11 (2004)
- B. Steffen, “Electro-optic time profile monitors for femtosecond electron bunches at the soft x-ray free-electron laser FLASH“, Phys. Rev. ST Accel. Beams 12, 032802 (2009)

# A bit of theory

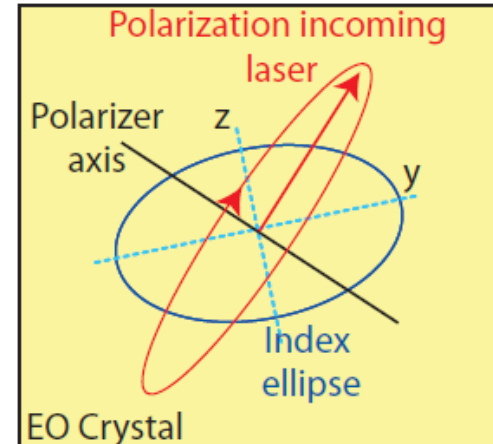
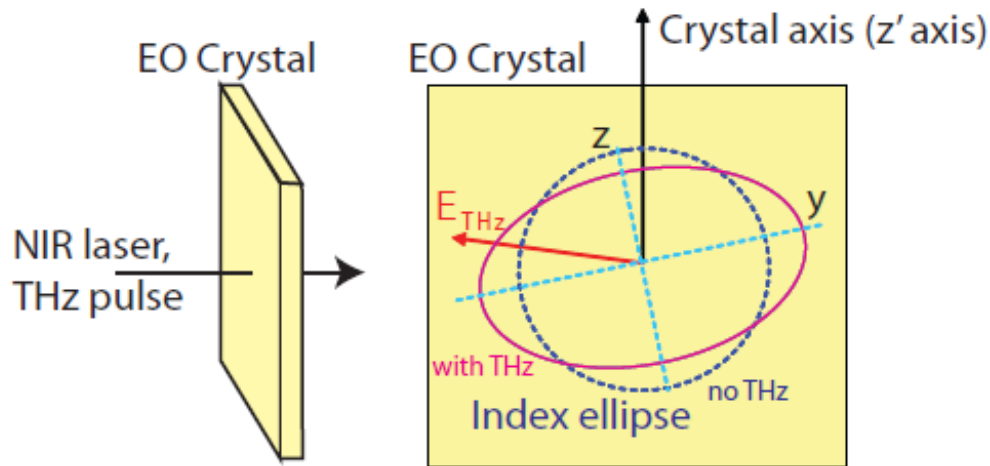

$$\delta n_z = \frac{n_0^3 r_{41} E_{\text{THz}}}{4} \left( \cos \phi + \sqrt{1 + 3 \sin^2 \phi} \right)$$

$$\Gamma_j(\omega) = \frac{2\pi}{\lambda_0} L \delta n_j(\omega) T_{\text{crystal}}(\omega),$$

$$T_{\text{crystal}}(\omega) = \frac{2}{1 + n_{\text{THz}}} \cdot \frac{\exp \left[ iL(n_{\text{gr}} - n_{\text{THz}}) \frac{\omega}{c} \right] - 1}{i \frac{\omega}{c} (n_{\text{gr}} - n_{\text{THz}})}$$

$$E_{M,j}(t) = E_{L,j}(t) e^{i\Gamma_j(t)}$$



# Spectral decoding

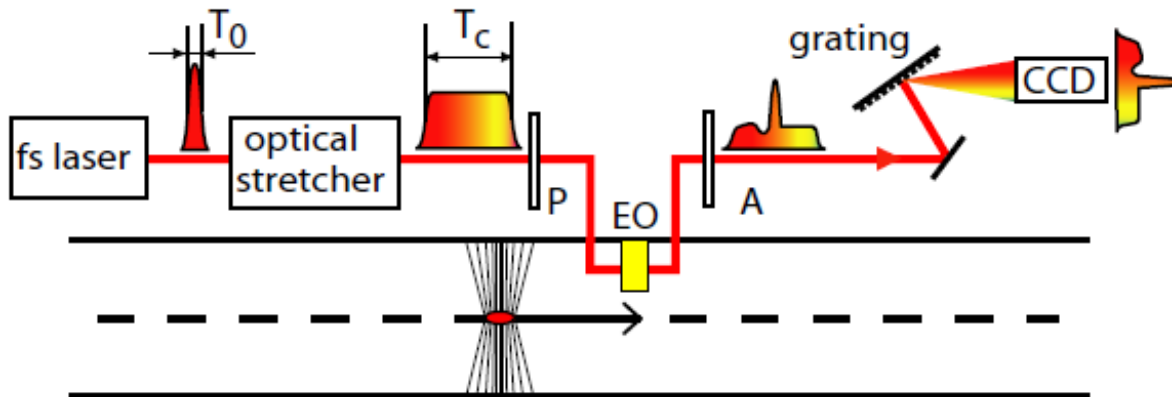

- Artifacts due to frequency mixing
- Minimum resolution in the order

J.R. Fletcher, Opt. Express 10, 1425 (2002)

$$T_{\text{lim}} \approx 2.6 \sqrt{T_0 T_c}$$

# Temporal decoding

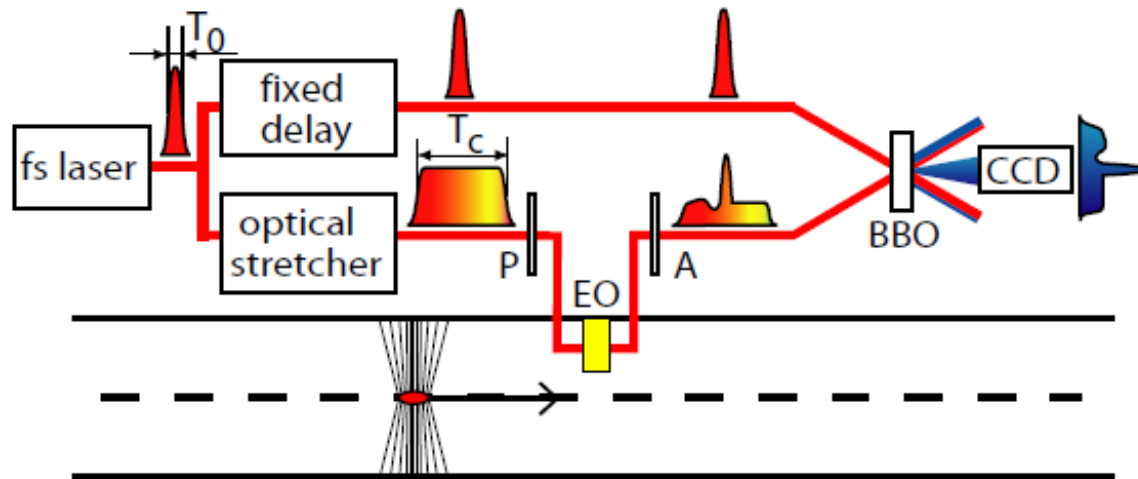

- Resolution : duration of the gate beam, thickness of the SHG crystal
- 50 fs or slightly better
- low efficiency SHG process, approx. 1mJ laser pulse energy necessary

# Temporal cont.

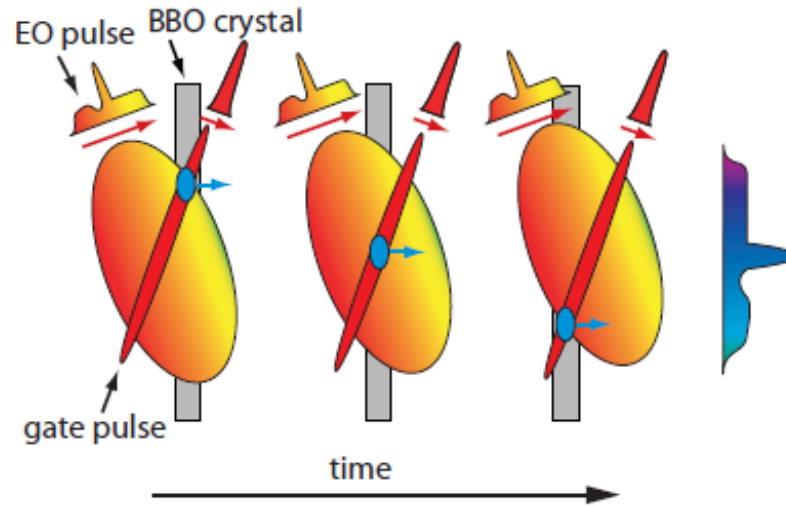

- The short gate pulse overlaps with different temporal slices of the EO pulse at different spatial positions of the BBO crystal. Thus the temporal modulation of the EO pulse is transferred to spatial distribution of the SHG light.

# Spatial decoding

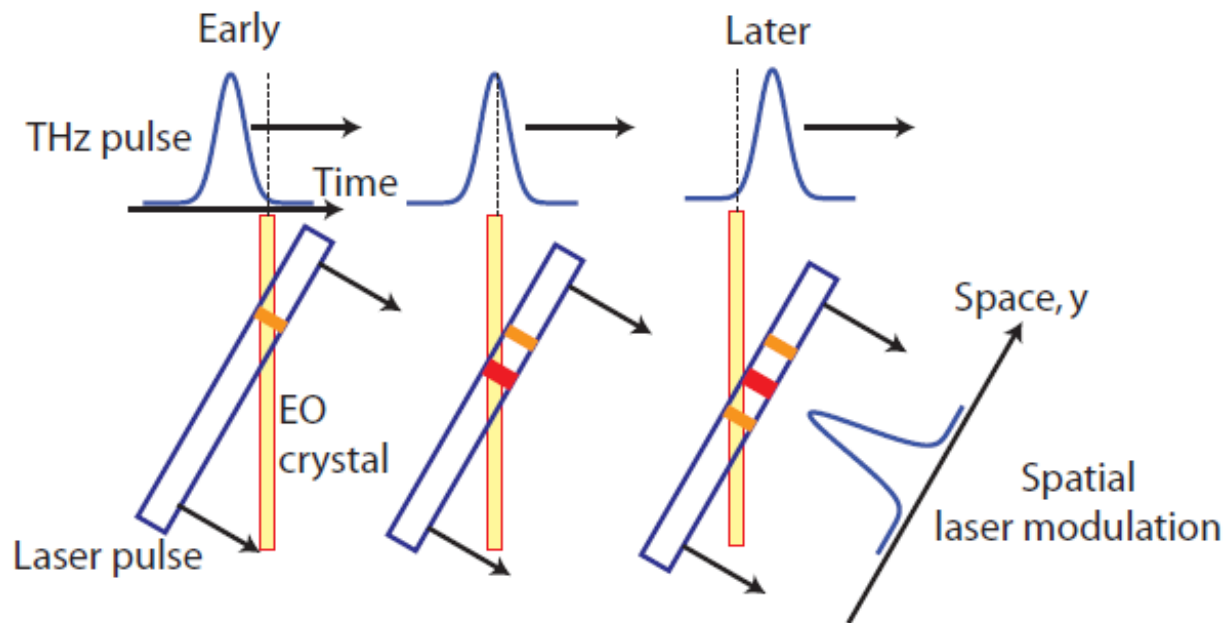
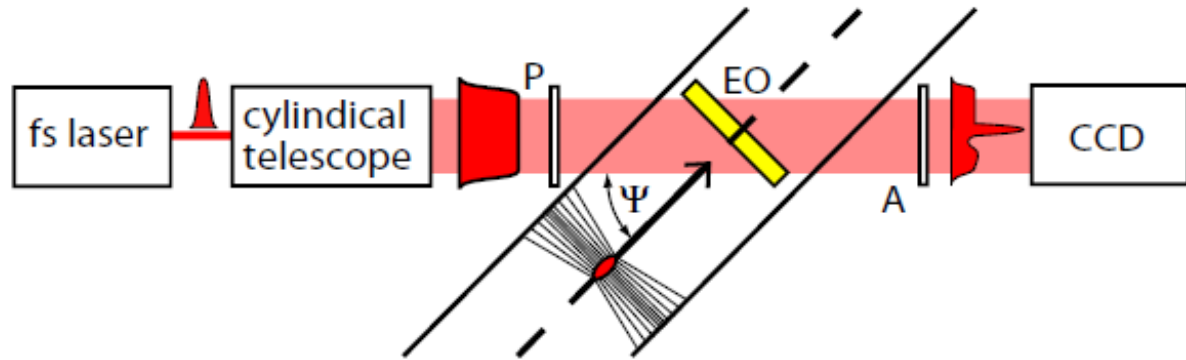

# EOS setup

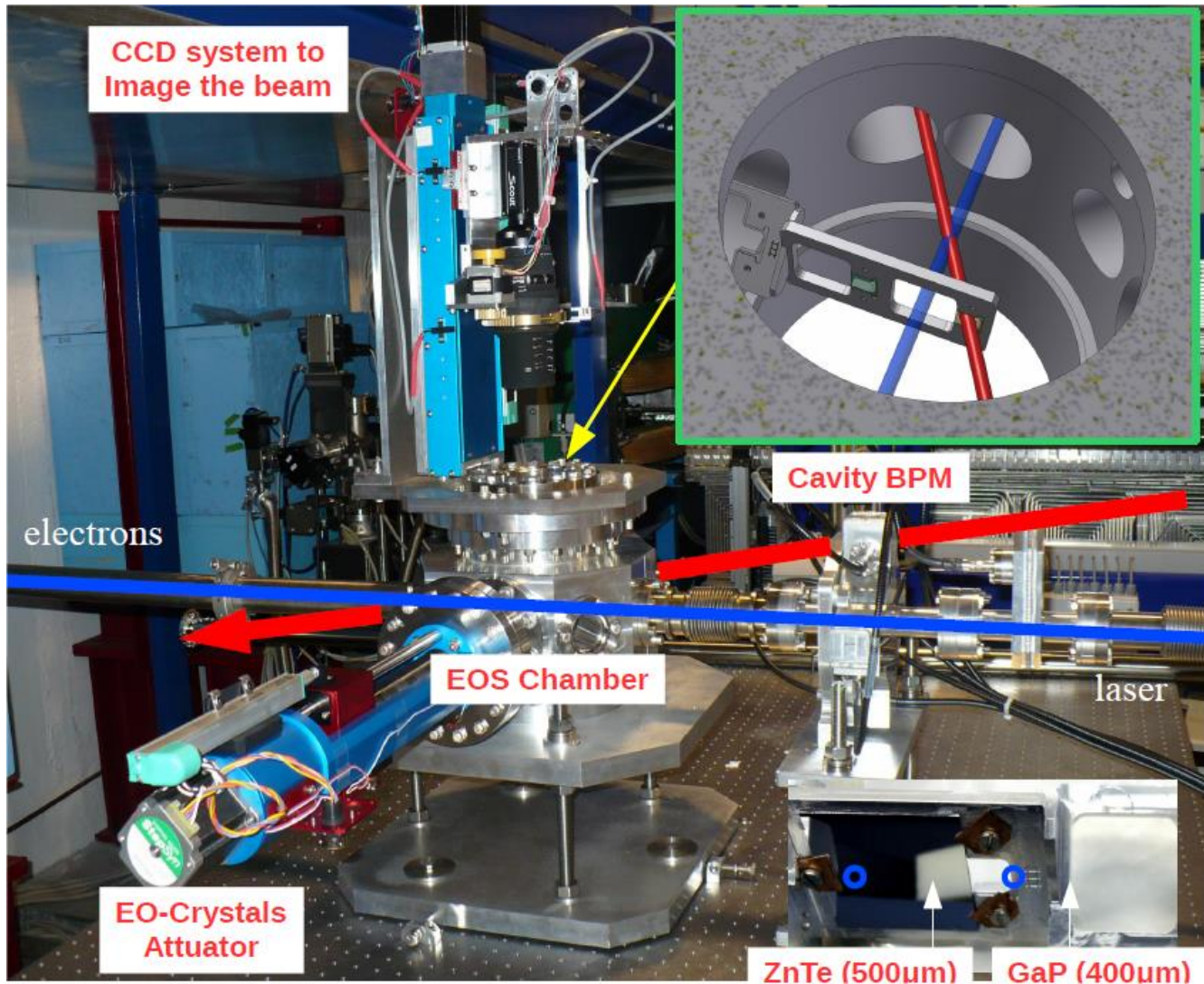

- High brightness beam demands particular diagnostic techniques in order to measure very small transverse emittance ( $<1$  mm-mrad) and very short bunch length ( $< 1$  ps)
- Intercepting or not intercepting diagnostics are recommended in some cases
- Some diagnostics are already state of the art
- Some others are still developing
- New ideas are daily tested, so if you want your part of glory start to think about today!

- Thank you for your attention