

Imaging using ionizing radiations

IV – Positron Emission Tomography

Ziad El Bitar
ziad.elbitar@iphc.cnrs.fr

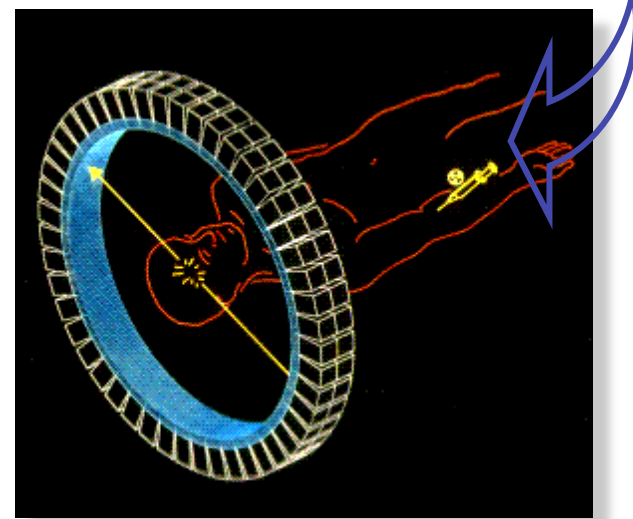
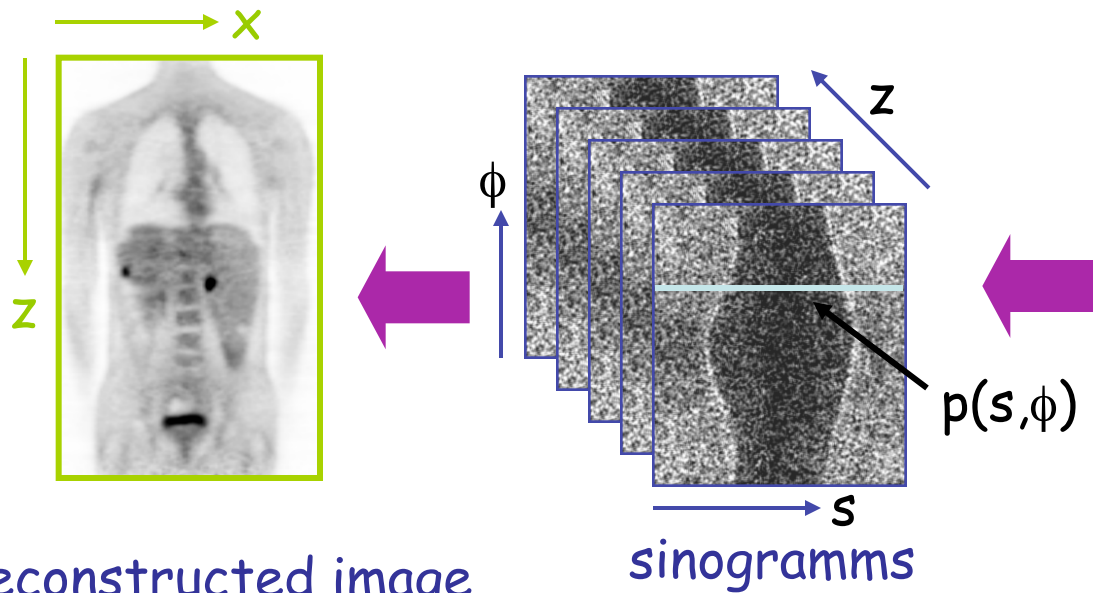
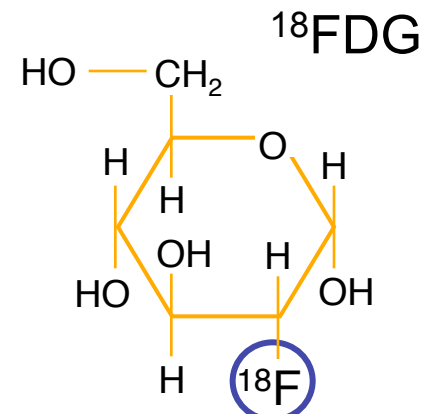
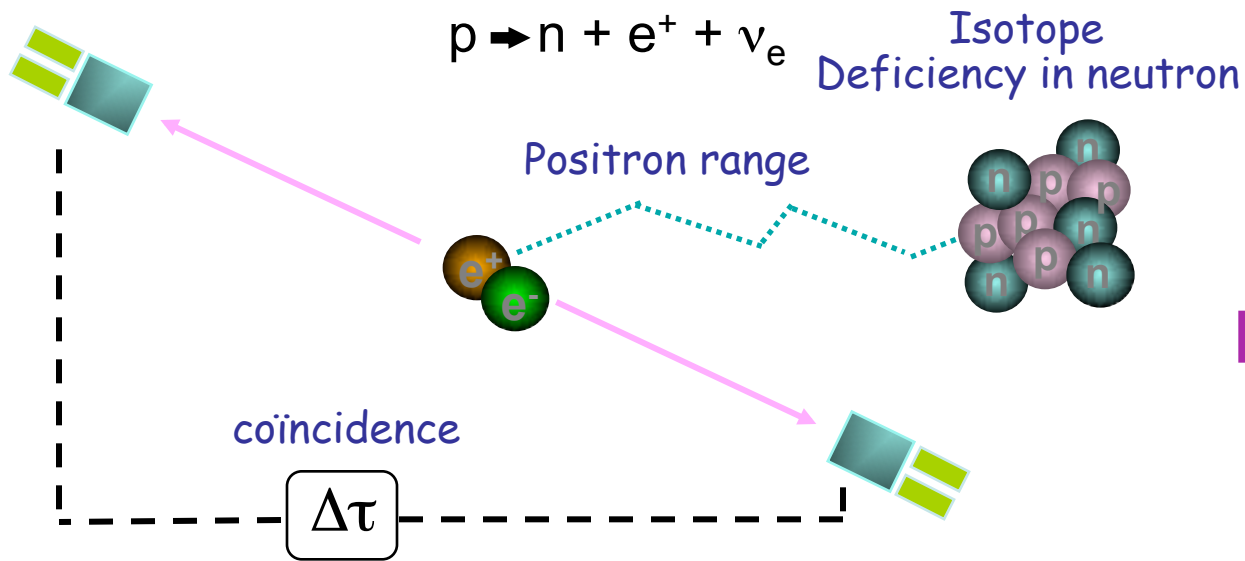

Positron mean range

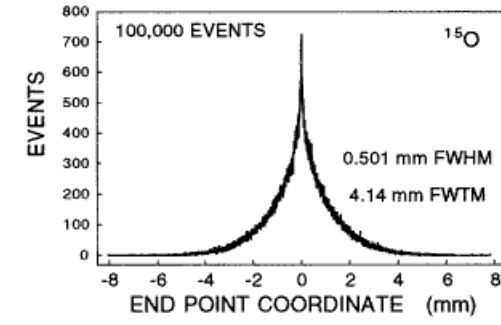
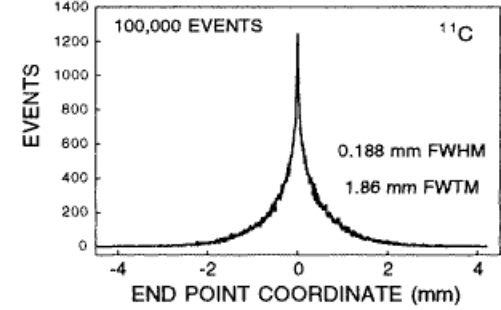
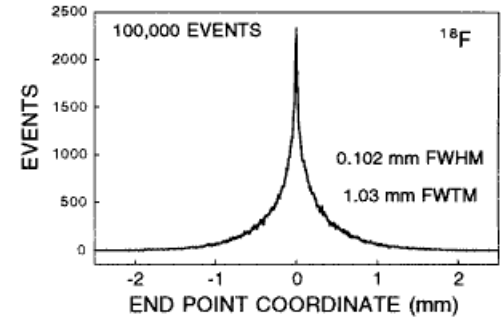
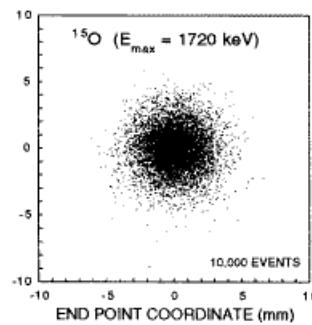
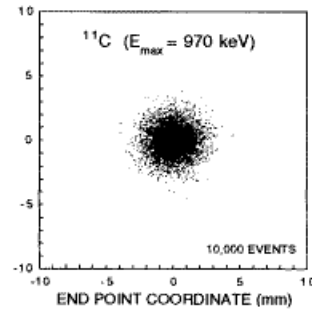
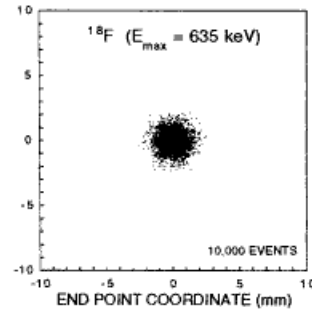
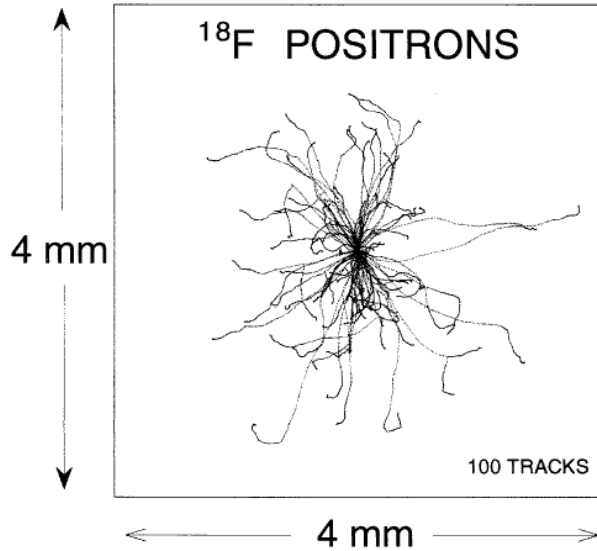

$$P(x) = C e^{-k_1 x} + (1 - C) e^{-k_2 x} \quad x \geq 0$$

	^{18}F	^{11}C	^{13}N	^{15}O
C	0.516	0.488	0.426	0.379
k_1 (mm^{-1})	0.379	0.238	0.202	0.181
k_2 (mm^{-1})	0.031	0.018	0.014	0.009

Acolinearity

This effect depends on the energy of the positron

Angular distribution is almost gaussian
With an LTMH around $0,5^\circ$

$$R_{AC} = 0,0022 \times D$$

D = System diameter

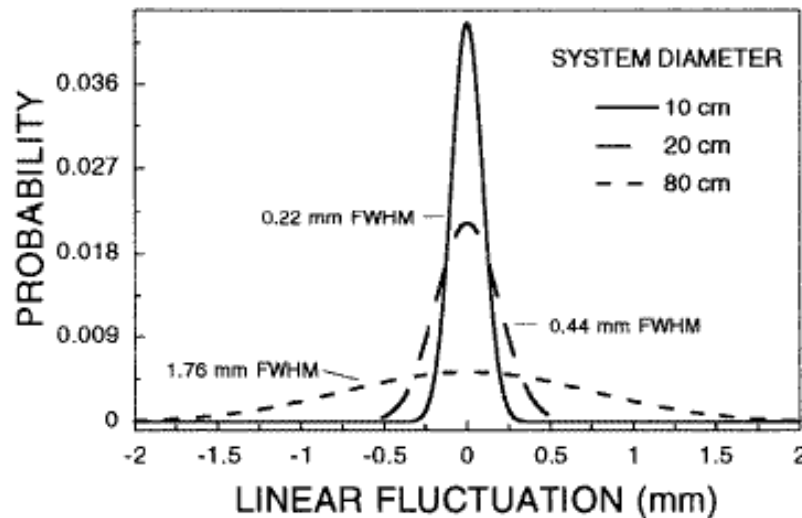

□ β^+ in a magnetic field

Objective : Limitation of the positron range (flight) in presence of an axial magnetic field – Combination PET/IRM

- Resolution phantom: \varnothing 1 mm – 2,5 mm
- Simulation of a high resolution animal PET system : 1.8 mm

^{18}F

$B = 0$ Tesla

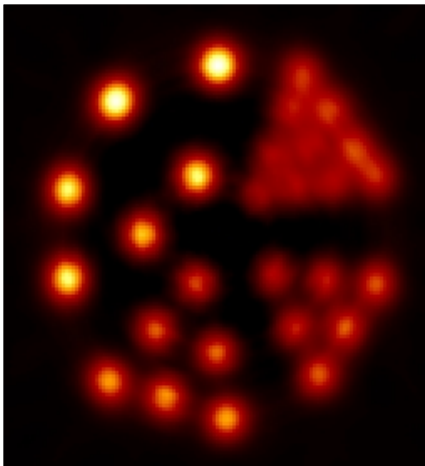

^{15}O

$B = 0$ Tesla

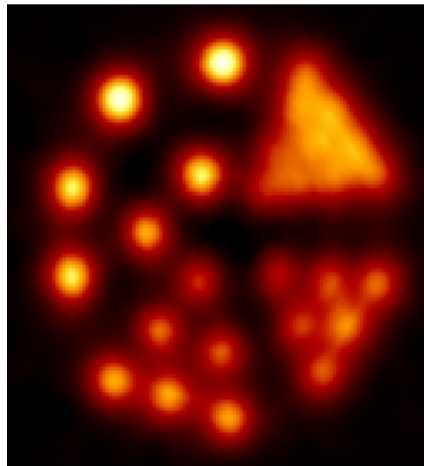

^{15}O

$B = 15$ Tesla

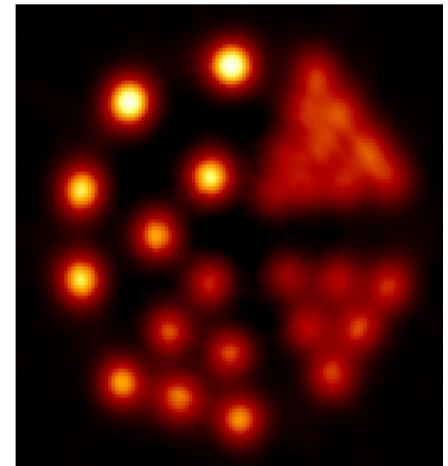

Physical principles: short remindr

Question:

Calculate the minimal energy of a 511 keV photon after undergoing a Compton scatter. What is the energy of the recoil electron ?

$$E_c (keV) = \frac{E_0}{1 + \frac{E_0}{m_e c^2} (1 - \cos \theta)}$$

The minimum energy is obtained when the maximum of energy is transferred to the electron. This happens for $\theta = 180^\circ$

$$E_c (keV) = \frac{511}{2 - \cos \theta}$$

$$E_e (keV) = E - E_c = 511 \frac{1 - \cos \theta}{2 - \cos \theta}$$

Numerical application: find the energy of the scattered photon and the recoil electron

$$E_c (keV) = \frac{511}{2 - \cos 180^\circ} = 170 keV$$

$$E_e = E - E_c = 511 - 170 = 340 keV$$

Interaction cross section

$$I(x) = I(0) \exp(-\mu x)$$

$$\mu \approx \mu_{\text{compton}} + \mu_{\text{photoelectric}}$$

@ 511 keV

	μ_{Compton} (cm ⁻¹)	$\mu_{\text{Photoelectric}}$ (cm ⁻¹)	μ (cm ⁻¹)
Soft tissues	~0,096	~ 0,00002	~ 0,096
Bone	~ 0,169	~ 0,001	~ 0,17
BGO	0,51	0,40	0,96
Lead	0,76	0,89	1,78
Tungsten	1,31	1,09	2,59

Question:

What is the probability that a 511 keV photon undergoes a Compton scatter @ 7.5 cm inside the brain?

What would be the probability value for a photon coming from the liver @ 20 cm from the body surface?

$$\frac{I(x)}{I(0)} = \exp(-\mu x)$$

$$\mu_{\text{Compton}} = 0,096 \text{ cm}^{-1}$$

Brain: $x = 7,5 \text{ cm}$; $I(x)/I(0) = 0,49$ (49 % of photons are unscattered)

Liver: $x = 20 \text{ cm}$; $I(x)/I(0) = 0,15$ (15 % of photons are unscattered)

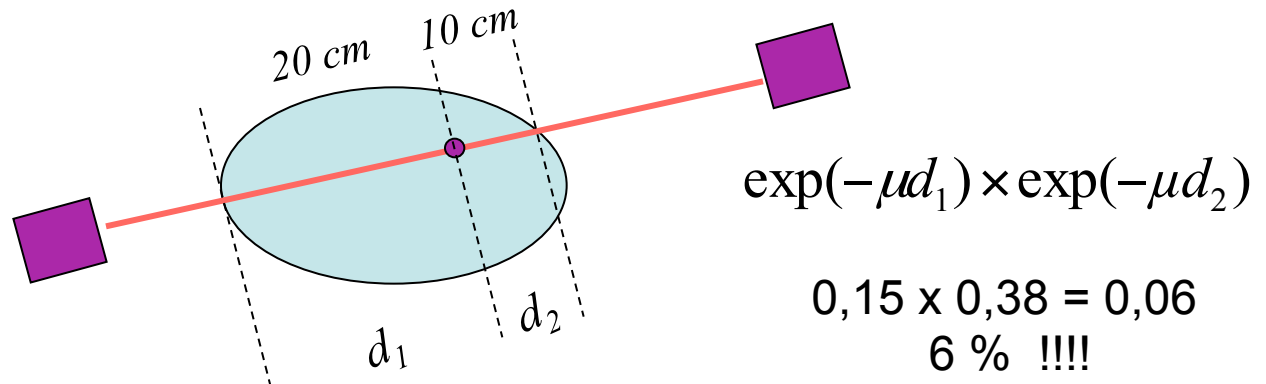

The objective of the detection system is to detect photons coming from the body and that did not scatter.

Need for a dense material

Optimize the rate of photoelectric/compton cross sections.

Question:

Calculate the thickness of BGO required to stop 90% of 511 keV photons.

$$\frac{I(x)}{I(0)} = 0,1 = \exp(-0,96 \times x)$$

$$x = 2,4 \text{ cm}$$

Used scintillators

Scintillators	Density (g/cm ³)	Yield (ph/511keV)	Decay (ns)	Refraction index	μ @511 keV (cm ⁻¹)	$\mu_{\text{Ph}}/\mu_{\text{C}}$ @511 keV
NaI:Tl	3,67	19400	230	1,85	0,34	0,22
BGO	7,13	4200	300	2,15	0,96	0,78
LSO:Ce	7,40	~ 13000	~ 47	1,82	0,88	0,52
GSO:Ce	6,71	~ 4600	~ 56	1,85	0,70	0,35
BaF ₂	4,89	700; 4900	0,6; 630	1,56	0,45	0,24
YAP:Ce	5,37	~ 9200	~ 27	1,95	0,46	0,05
LaBr ₃	5,29	32000	16	1,9	0,45	
LaCl ₃	3,86	23000	25	1,9	0,36	
LuAP	8,34	5110	18		0,95	
LYSO	7,11	17300	41	1,81	0,83	

Used photodetectors

Photomultiplier

HPD

MCP

Solid detector

Photodiode

Avalanche photodiode

Important parameters to consider:

Quantum efficiency

Gain

Signal to noise ratio

Speed

Geometry

Cost/readout channel

Photodetector/Crystal coupling

« Block detector »

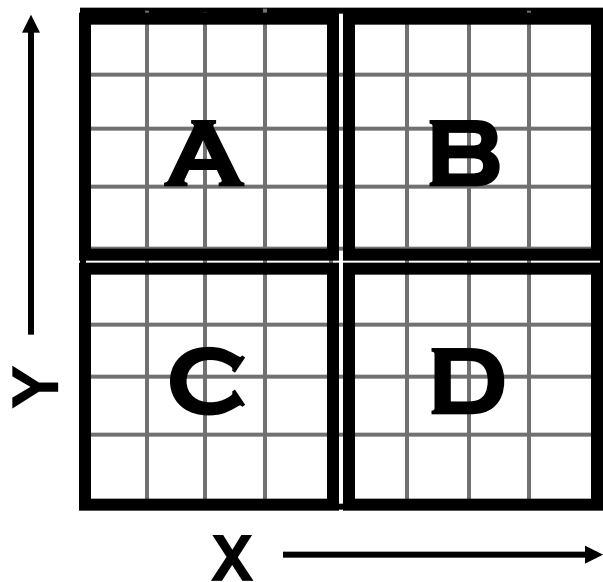
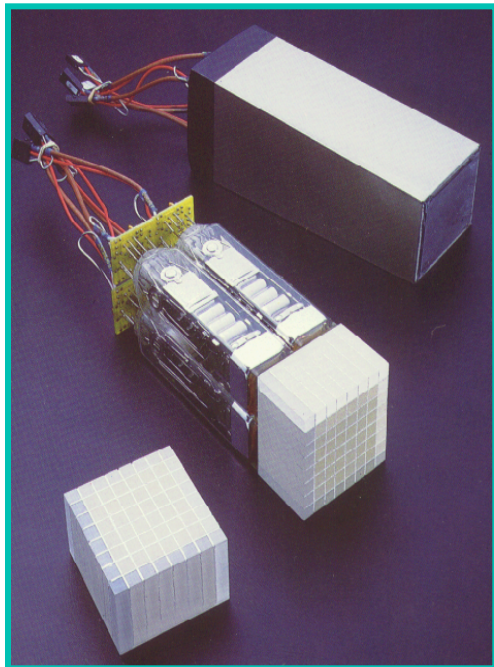

$$X = \frac{(D + B) - (C + A)}{\Sigma}$$

$$Y = \frac{(A + B) - (C + D)}{\Sigma}$$

$$\Sigma = A + B + C + D$$

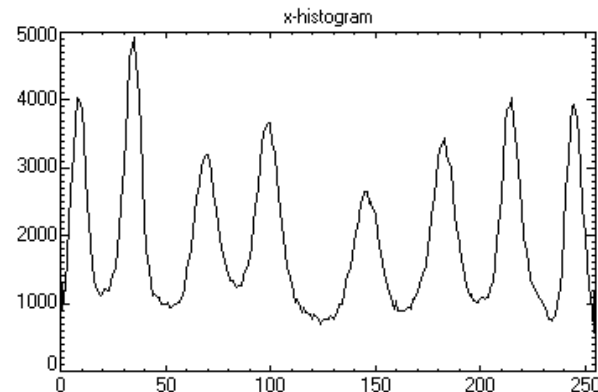
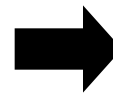
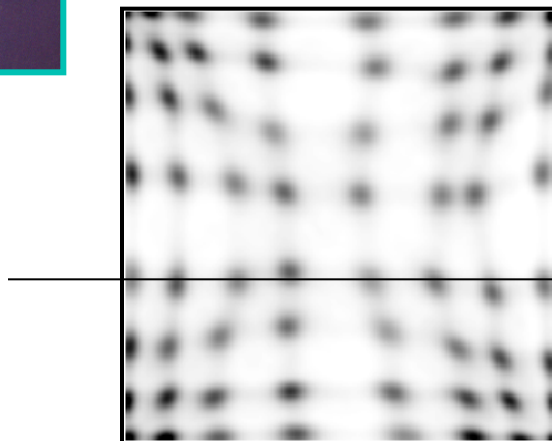

Photodetector/Crystal coupling

Extension of « Block detector »: « Quadrant sharing »

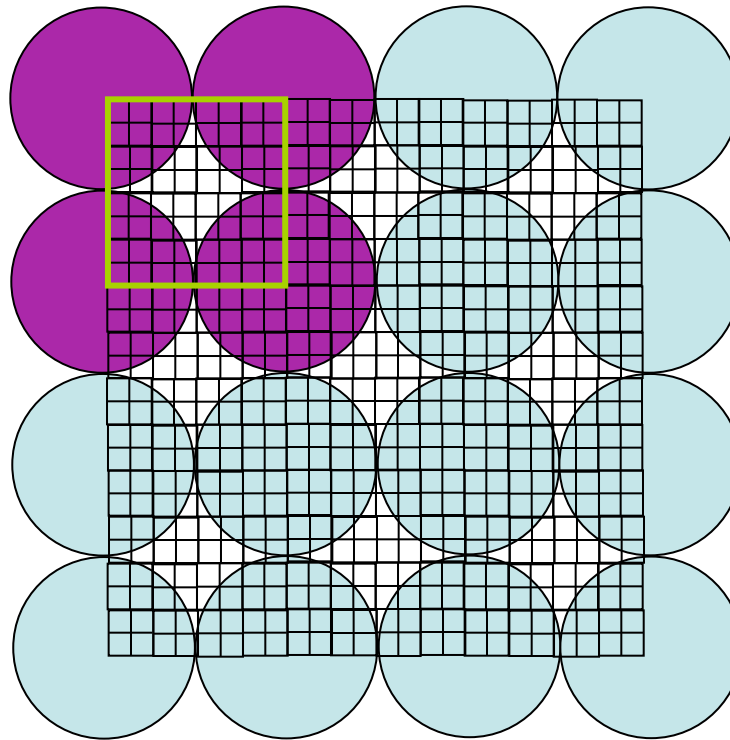
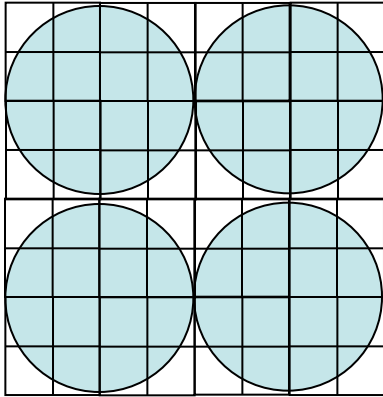

4 PMT for 64 pixels
Pixel size / 2
Cost reducing

Adapted for large detectors
Dead zones edges

Photodetector/Crystal coupling

Continuous detector

Large FOV: 40-50 cm
Dead zone at edges

Curved detector possible



Barycenter calculation of the interaction position
The spatial resolution depends on the number of detected photons-> NaI:Tl etc...

25 mm = Compromise between resolution and efficiency

Thickness	$R_{\text{intrinsèque}}$
10 mm	3 mm
25 mm	4-5 mm

Should have the capability of generating many events, unless increasing the dead time ...

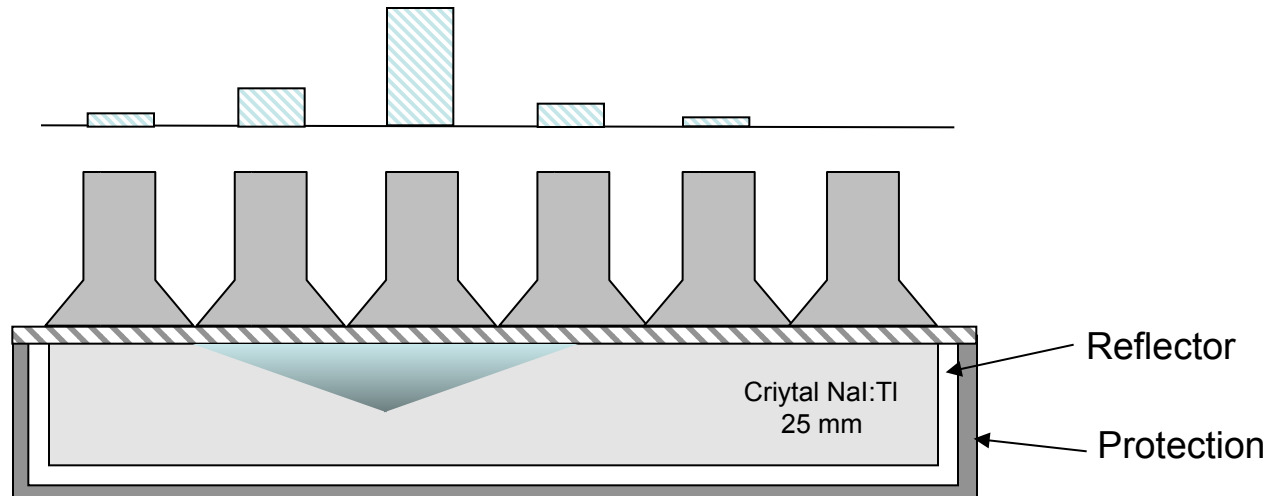

System configuration

Detection in coincidence

The time resolution of the system depends on
the constant decay of the used crystal
used electronic readout

Typically $\tau = 5-6 \text{ ns}$ for BGO-NaI:Tl
 $\tau = 2-3 \text{ ns}$ for LSO

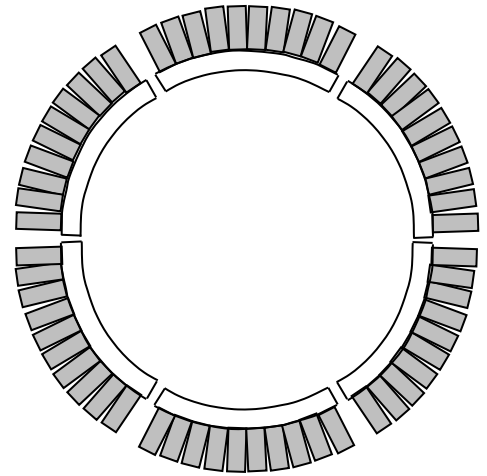
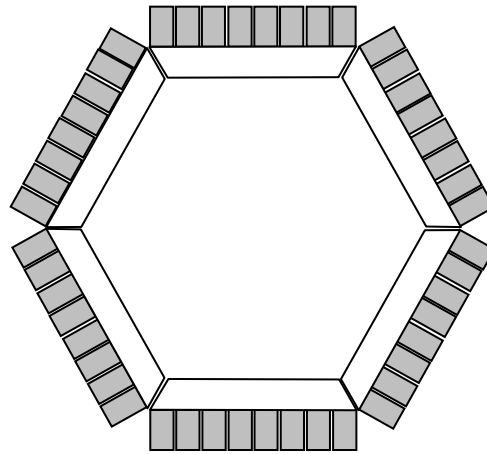
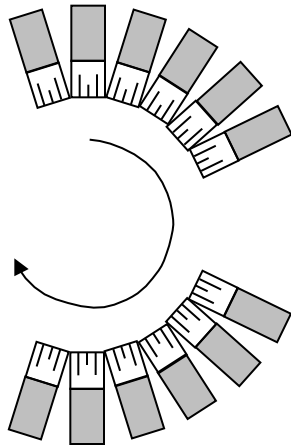
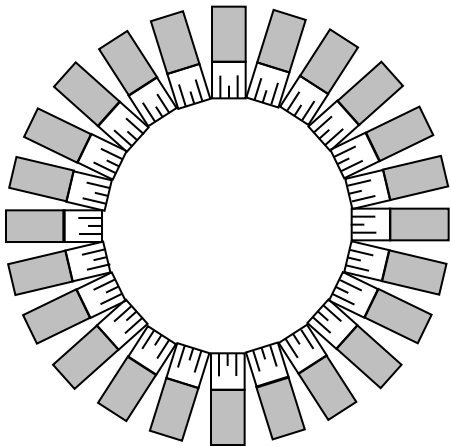

Different registered events

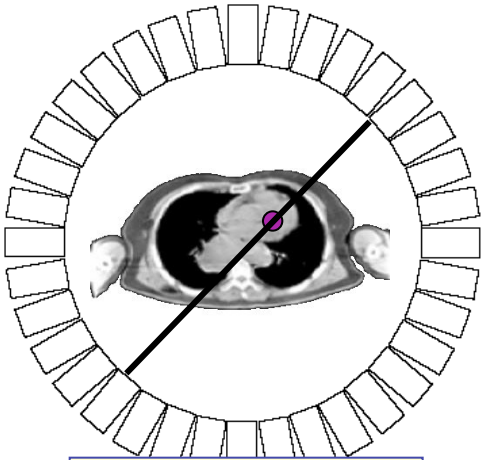

True coincidences $T \sim \text{activité}$

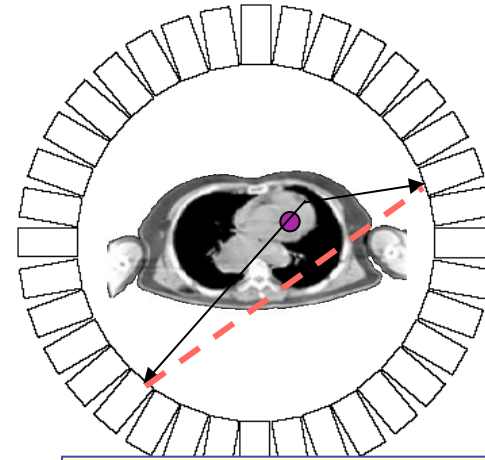

Scattered Coincidences $S \sim f \times \text{activité}$

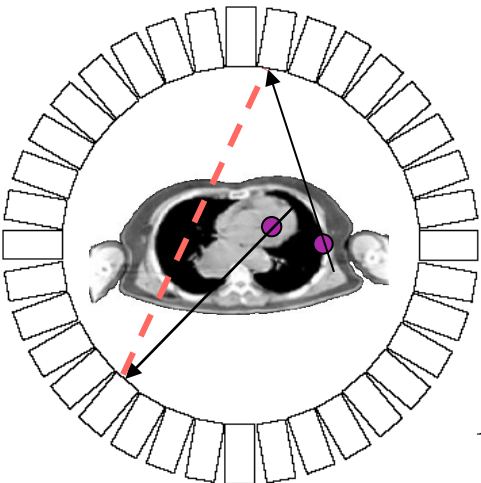

Random Coincidences $R \sim \text{activity}^2$

Measurement:
 $T + S + R$

$$N_R = 2\tau N_1 N_2$$

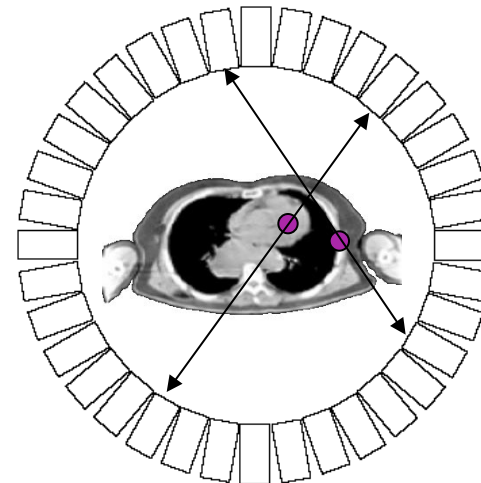

Mutiple Coincidences

Resolution: Response function

The intrinsic detector resolution can be derived in 2 components

Geometry (Considers a perfect detector)

Physics (Physical properties of the detector)

Discrete detector

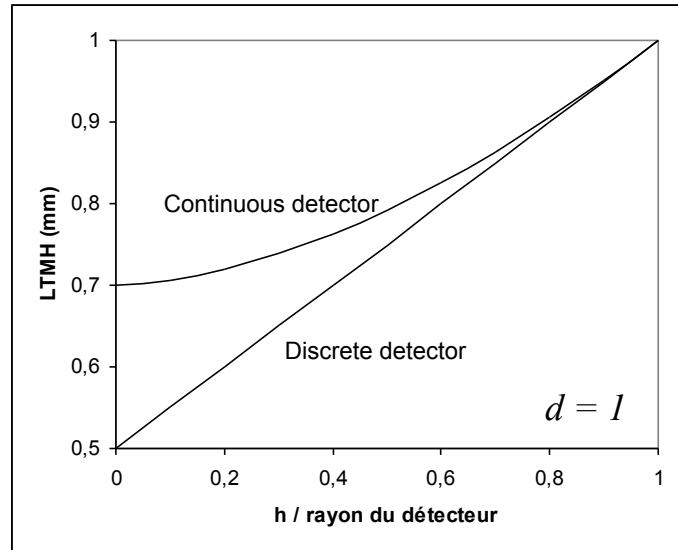
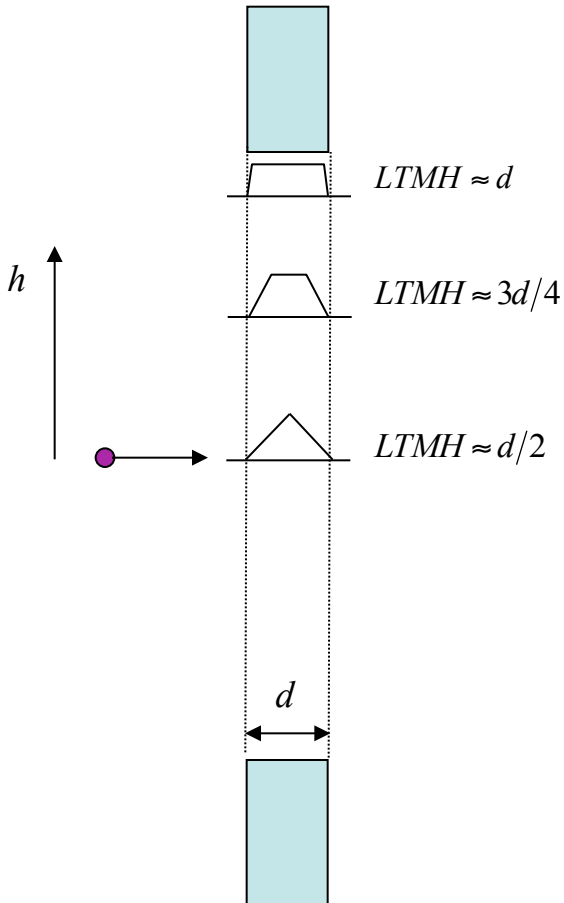

Continuous detector

Intrinsic resolution = d

$LTMH \approx d$

$LTMH \approx 0,85d$

$LTMH \approx d/\sqrt{2}$

Intrinsic resolution = d

Parallax problem

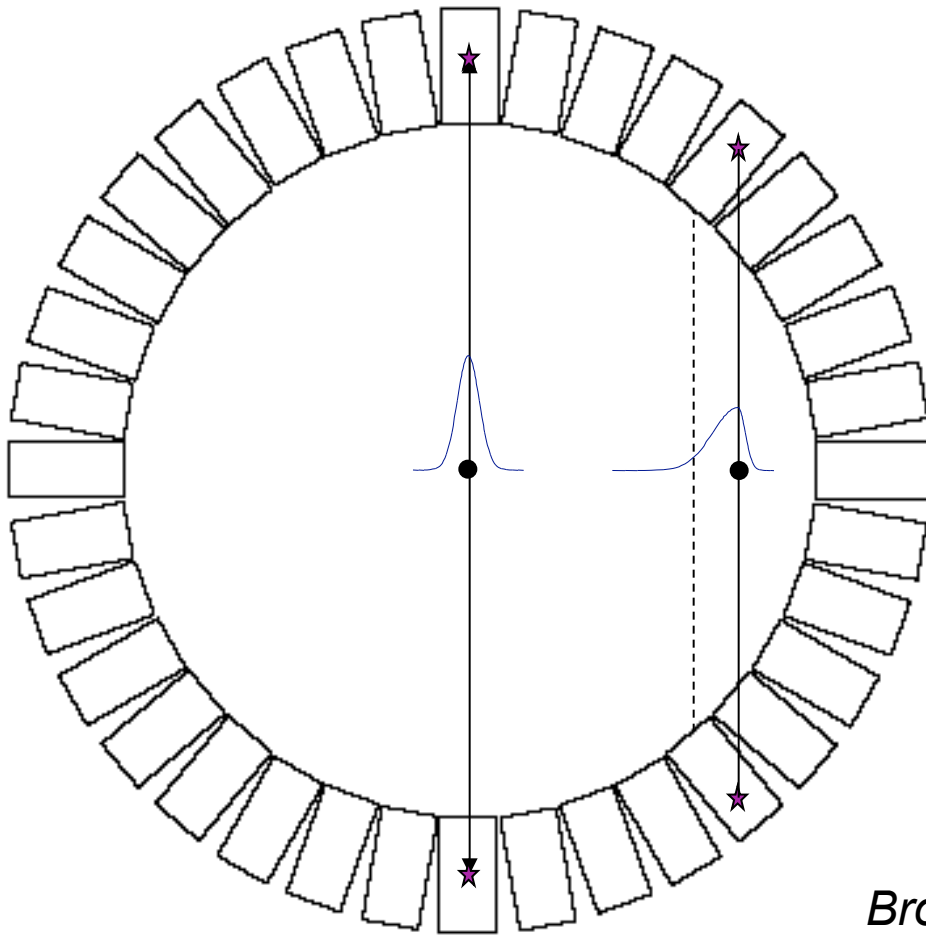

Two important consequences
Broadening of the response (Assymetry)
False positionning

The resolution of a detector system the quadratic sum of the « elementary » resolutions

Positron mean range
Acolinearity
Geometrical factors
Intrinsic spatial resolution (continuous detector)
Physical factors

Question:

Hypothesis: Different responses can be approximated by gaussian functions

Calculate the system resolution for a ^{18}F source centred in the field of view of a clinical scanner which diameter is 80 cm and the size of a detection element is 6 mm

$$R_i = 6\text{mm} / 2 = 3\text{mm}$$

$$R_{AC} = 0,0022 \times 800 = 1,76\text{mm}$$

$$R_{positon} = 0,102\text{mm}$$

$$R_{système} = \sqrt{3^2 + 1,76^2 + 0,102^2} = 3,48\text{mm}$$

Detection efficiency

The number of registered events is given by

The amount of injected radioactivity

Fraction of radioactivity targeting the Region Of Interest (ROI)

Duration of the exam

Detection efficiency of the PET system

Unit

Cps/Bq/ml

The system efficiency is the product of several factors

Detector efficiency @ 511 keV

Detection solid angle

Source positioning with respect to detector

The width of the energy window

The width of the time window

Detection efficiency

The detection efficiency of an elementary detector is the product of

The probability to detect an incident photon
Times

The fraction of events selected in the energy window

$$\varepsilon = \left(1 - e^{-\mu d}\right) \times \Phi$$

μ = linear attenuation coefficient of the material
 d = material thickness

Detection efficiency in coincidence

$$\varepsilon = \left(1 - e^{-\mu d}\right)^2 \times \Phi^2$$

System geometrical efficiency

The product of

Detection solid angle covered by the detector for a given source position (Ω)
Filling rate (Materials volume / total volume) (ϕ)

$$\Omega = 4\pi \sin\left[\tan^{-1}\left(A/D\right)\right]$$

Point source centred in a circular system
With diameter D
And axial coverage A

$$\phi = \frac{\text{section} \times \text{height}}{(\text{section} + \text{deadzone}) \times (\text{height} + \text{deadzone})}$$

Detection efficiency of the system

$$\eta \approx 100 \times \frac{\varepsilon^2 \varphi \Omega}{4\pi}$$

Question:

Calculate the detection efficiency of a point source centred in the field of view of the system.

TEP: simple detector ring of 80 cm diameter composed of detector elements whom dimensions are 4,9 x 6 x 30 mm³.

Reflector size: 0,25 mm

80% of the events are selected by the energy window

$$\varepsilon = \left(1 - e^{-(0,96 \times 3)}\right) \times 0,8 = 0,755$$

$$\Omega = 4\pi \sin\left[\tan^{-1}(0,6/80)\right] = 0,094$$

$$\varphi = (4,4 \times 5,5) / (4,9 \times 6) = 0,823$$

$$\eta = 100 \times 0,755^2 \times 0,094 \times 0,823 / 4\pi = 0,35\%$$

Data representation

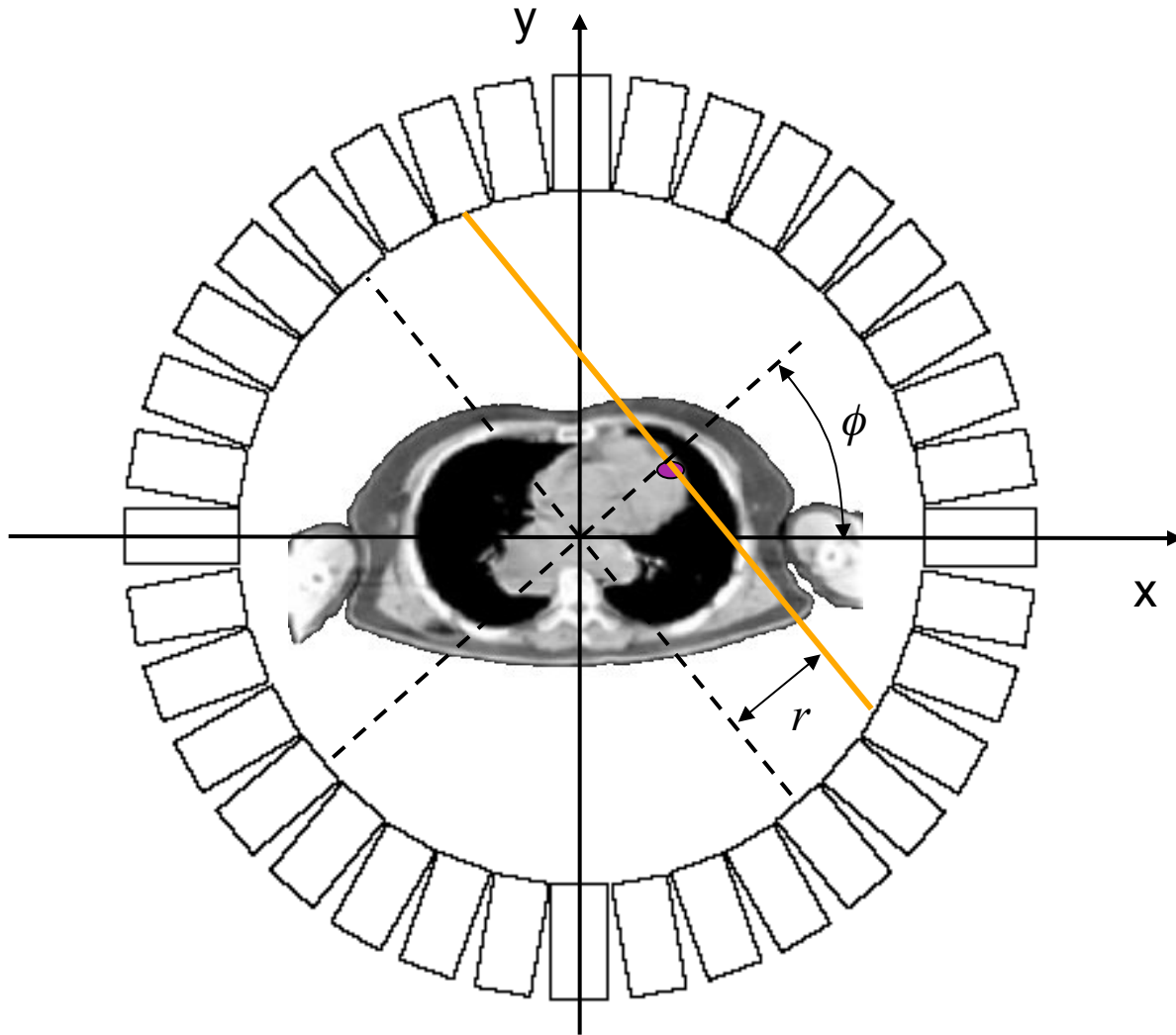

$$r = x \cos \phi + y \sin \phi$$

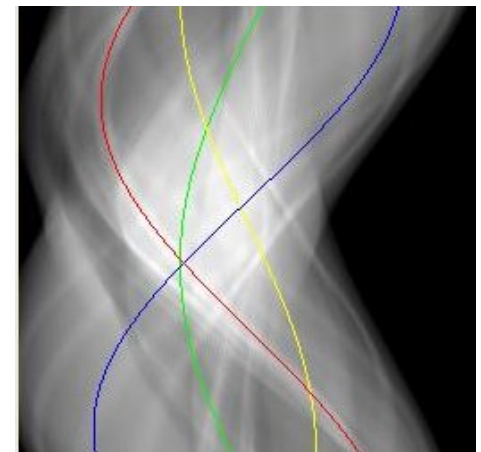
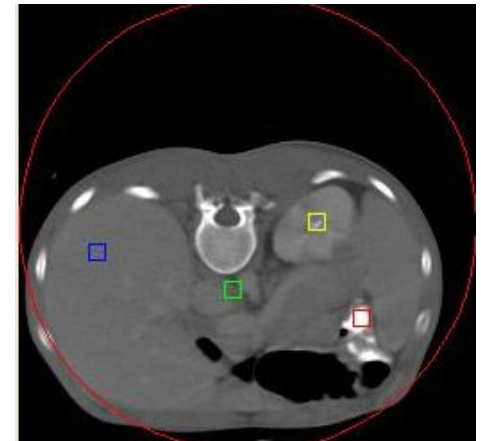

Acquisition 2D

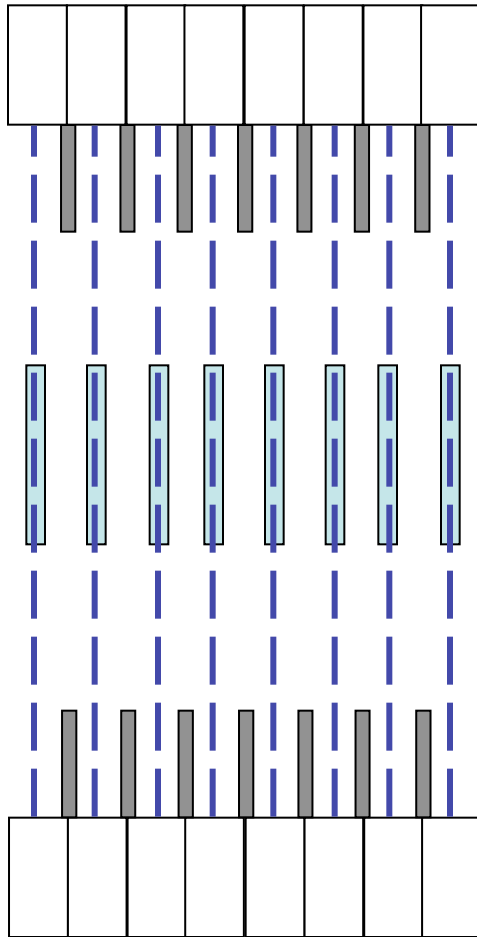

Direct slices

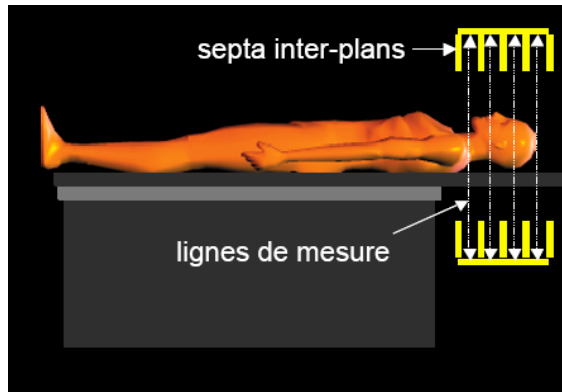

Number of slices

$$2N-1$$

with N = number of detectors

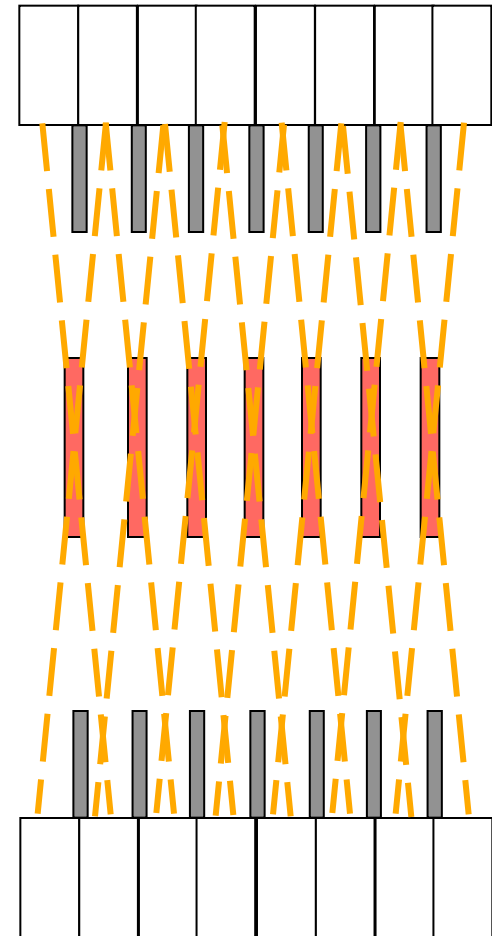

Crossed Slices

Acquisition 3D

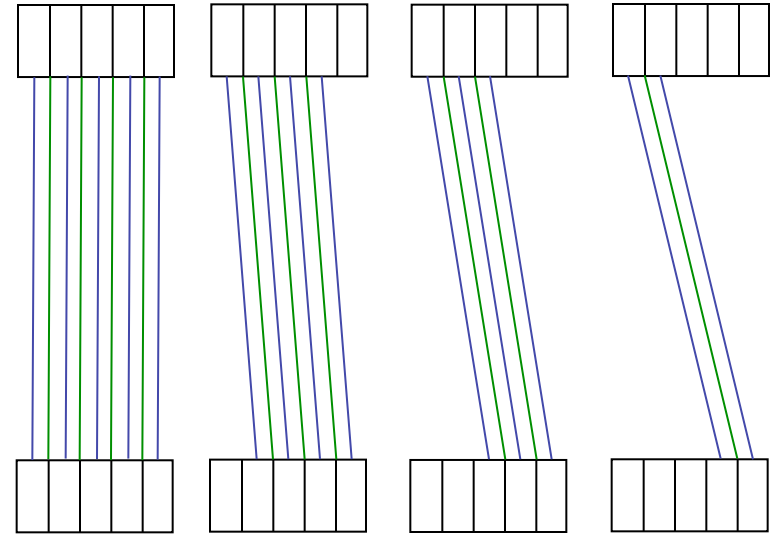
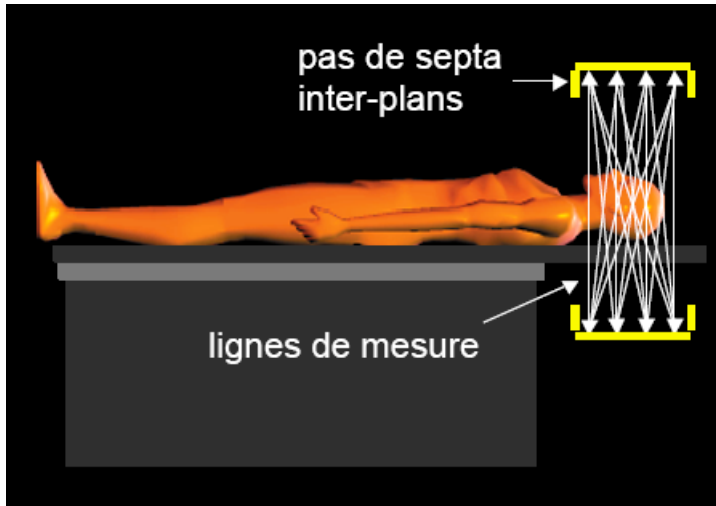

[¹¹C]flumazenil
images of
benzodiazapene
receptor
distribution

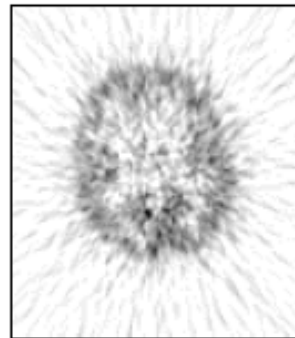

2D PET

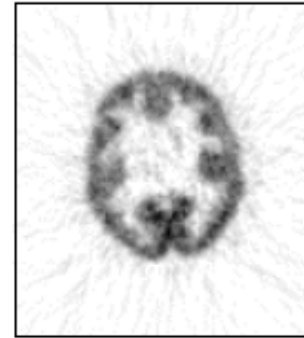

3D PET

Question:

Calculate the detection efficiency of a point source centred in the field of view of the system.

TEP: 16 detector ring of 80 cm diameter composed of $4,9 \times 6 \times 30 \text{ mm}^3$ detector elements.

Reflector size: 0,25 mm

80% of the events are selected by the energy window.

3D Acquisition mode.

$$\varepsilon = (1 - e^{-(0,96 \times 3)}) \times 0,8 = 0,755 \quad \textit{inchangé}$$

$$\Omega = 4\pi \sin\left[\tan^{-1}(0,6 \times 16/80)\right] = 1,50$$

$$\varphi = (4,4 \times 5,5)/(4,9 \times 6) = 0,823 \quad \textit{inchangé}$$

$$\eta = 100 \times 0,755^2 \times 1,50 \times 0,673 / 4\pi = \underline{5,59\%} \quad \textit{à comparer à 0,35 \%}$$

Question:

BGO -> LSO

$$\varepsilon = (1 - e^{-(0,88 \times 3)}) \times 0,9 = 0,836$$

$$\Omega = 4\pi \sin\left[\tan^{-1}(0,6 \times 16/80)\right] = 1,50 \quad \textit{inchangé}$$

$$\varphi = (4,4 \times 5,5)/(4,9 \times 6) = 0,823 \quad \textit{inchangé}$$

$$\eta = 100 \times 0,836^2 \times 1,50 \times 0,673 / 4\pi = \underline{6,19\%} \quad \textit{à comparer à 5,59 \%}$$

Acquisition protocole

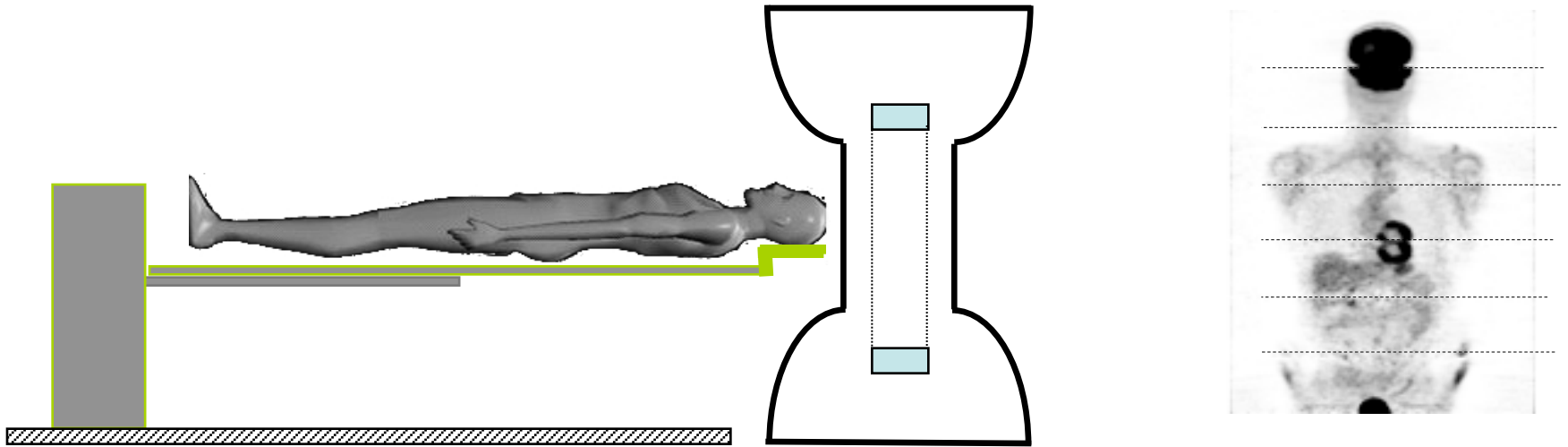

Static or dynamic acquisition in order to cover the whole body.

Data Correction

Attenuation correction in PET

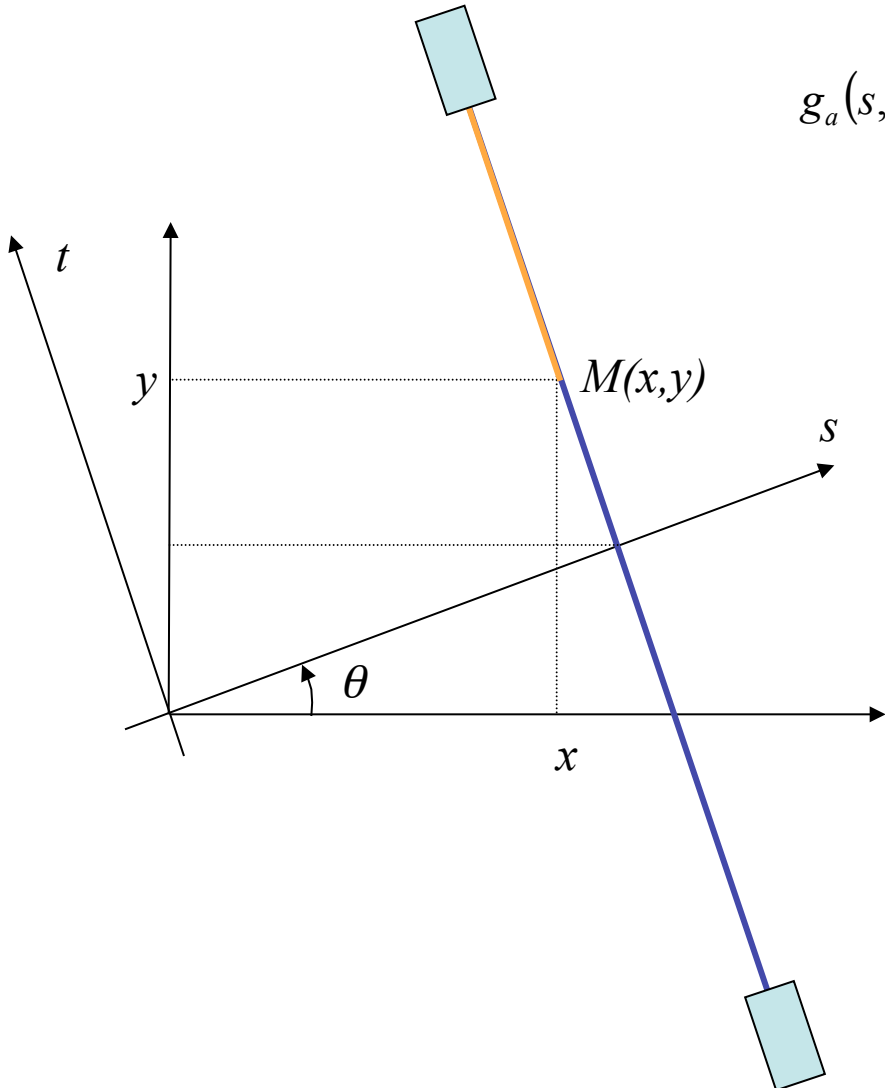

$$g_a(s, \theta) = \int_{-\infty}^M f(x, y) dt \cdot e^{-\int_{-\infty}^M \mu(x, y) dt'} \times \int_M^{+\infty} f(x, y) dt \cdot e^{-\int_M^{+\infty} \mu(x, y) dt'}$$

$$g_a(s, \theta) = \int_{-\infty}^{+\infty} f(x, y) dt \times e^{-\int_{-\infty}^{+\infty} \mu(x, y) dt'}$$

- **The attenuation:**
 - Do not depend on the localisation of the point of emission in the LOR.
 - Depends only on the attenuation integral $\mu(x, y)$ different of 0.
 - Depends on the function $\mu(x, y)$
 - → required measurement.
 - Example @ 511 keV:
 - Soft tissues: $\mu = 0,096 \text{ cm}^{-1}$
 - Muscle: $\mu = 0,1 \text{ cm}^{-1}$
 - Bone: $\mu = 0,134 \text{ cm}^{-1}$
 - Water: $\mu = 0,097 \text{ cm}^{-1}$

Attenuation artifact

- **Loss of an important number of photons**
 - Around 17 % of photons pairs emitted in the centre of the brain.
 - Around 5 % of photons emitted in centre of the thorax.
- **Bias in quantification.**
- **Unequal attenuation depending on the depth.**
- Error in diagnosis.

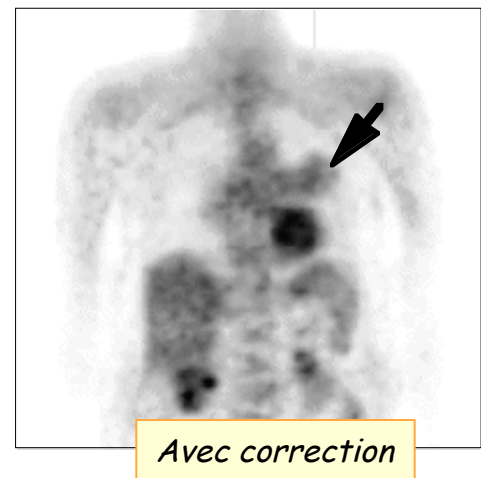
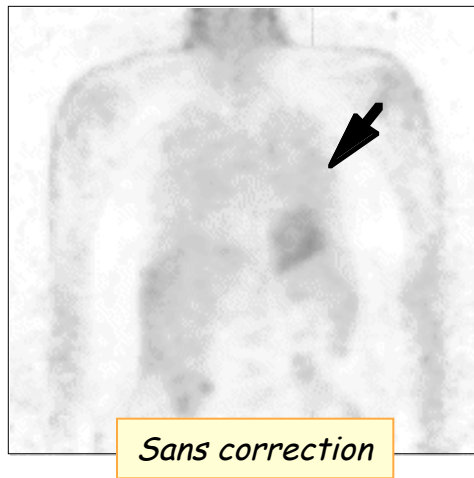
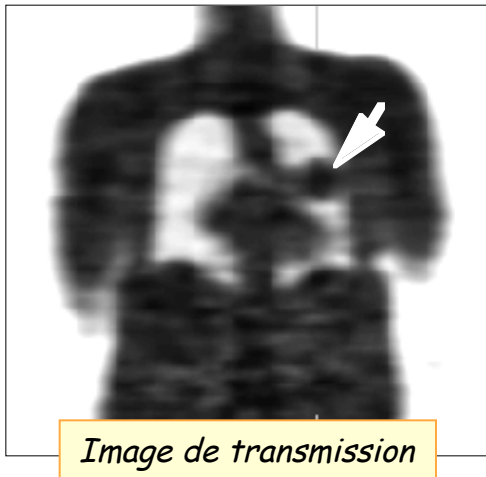

Measurement of the map of the linear attenuation coefficients.

- Source of ^{68}Ge

- Utilisable for a large period ($T = 271$ jours)
- Important dead time for detector near to the source.
- Acquisition: 15 to 30 min.
- Noisy image
- Small bias compared to true value (measured @ 511 keV)

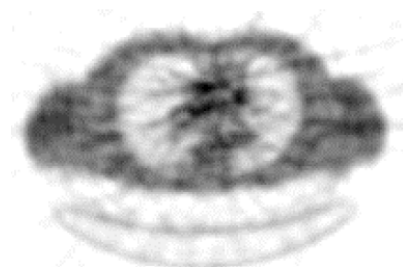
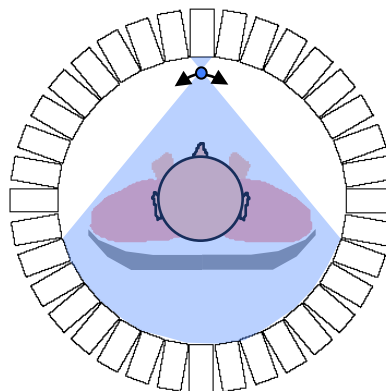

- Source of simple photons (^{137}Cs)

- Utilisable for a large period ($T = 30,2$ ans)
- Acquisition: 5 to 10 min.
- Biases with respect to true value
- Measurement @ 662 keV: requirement of value conversion $662 \text{ keV} \rightarrow 511 \text{ keV}$
- Possible simultaneous Emission/Transmission acquisition

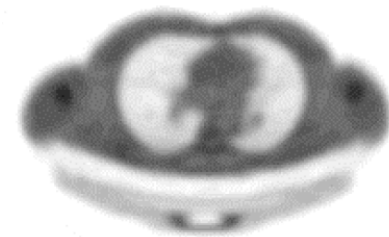
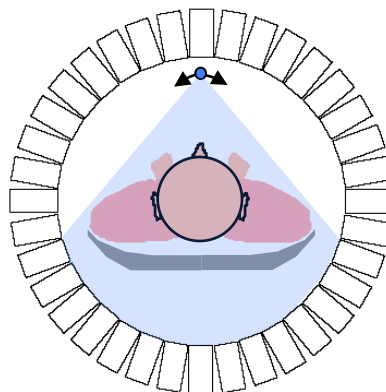

Acquisition protocole

- Projections acquisition in the presence of an object:

$$I(s, \theta) = I_0(s, \theta) \cdot e^{-\int_{-\infty}^{+\infty} \mu(x, y) dt}$$

- Full flux projections acquisition I_0
- Linear attenuation coefficient reconstruction $\mu(x, y)$ if required.
- Scaling coefficients if required.
- Calculation of attenuation correction factors (ACF):

$$e^{\int_{-\infty}^{+\infty} \mu(x, y) dt} = \frac{I_0(s, \theta)}{I(s, \theta)}$$

Attenuation correction

Two possible approaches

Projections correction

Projections multiplication

$$g_c(s, \theta) = \int_{-\infty}^{+\infty} f(x, y) dt \times e^{-\int_{-\infty}^{+\infty} \mu(x, y) dt'} \times ACF$$

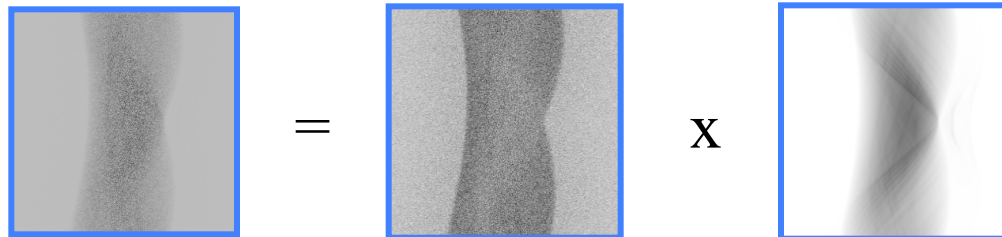

Reconstruction of corrected projections

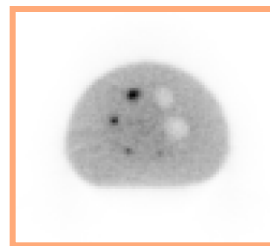

Correction during reconstruction

*Iterative reconstruction with the modeling
of the attenuation into the projector*

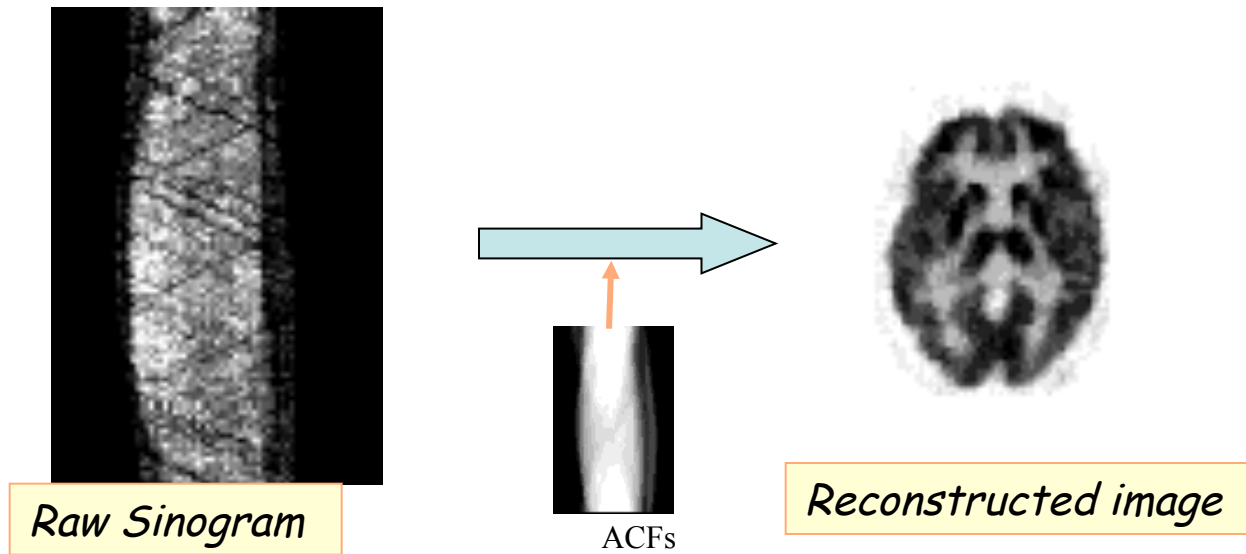

Problems related to attenuation correction

- Patient motion between emission and transmission
 - Data scaling
 - Emission/Transmission simultaneous acquisition
- Noise propagation in images corrected from attenuation
 - Filtering the attenuation map
 - Segmentation of attenuation map
 - Usage of low noise attenuation map

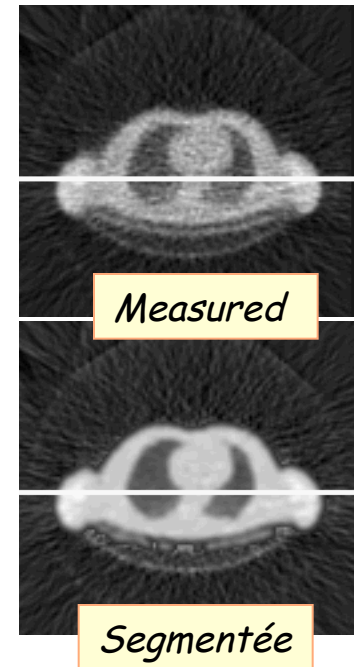

Compton scatter

○ In patient



Mispositioned coincidence

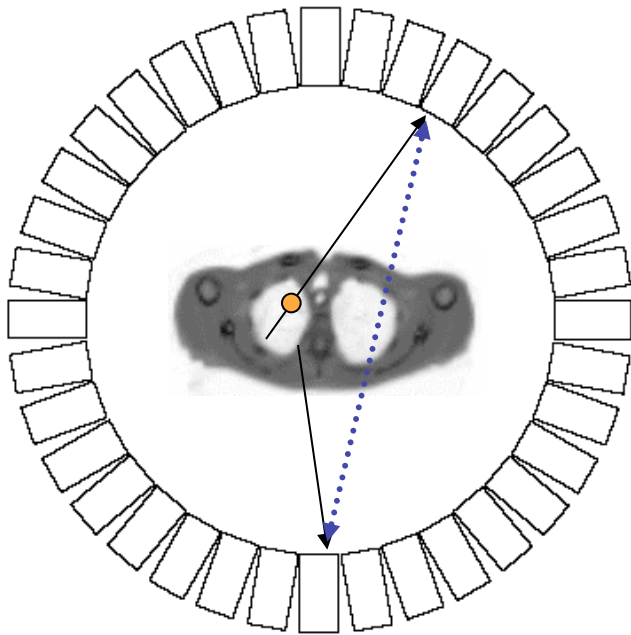

Detection solid angle of unique photons

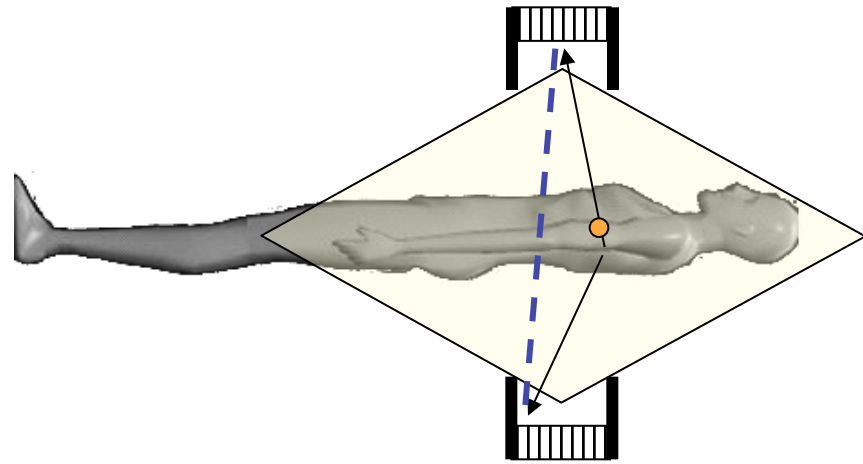

○ Dans le cristal



Détérioration de la résolution intrinsèque
Rejet d'événements

Scatter artifact in PET

- Mispositioned coincidences
 - Blurr
 - Loss in image contrast
 - Activity outside of the object
 - Quantitative bias
- More artifact in 3D artifact

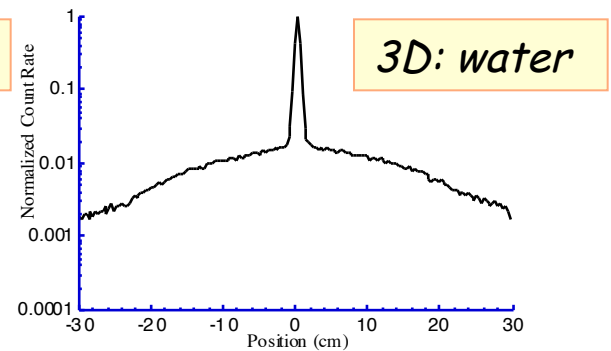
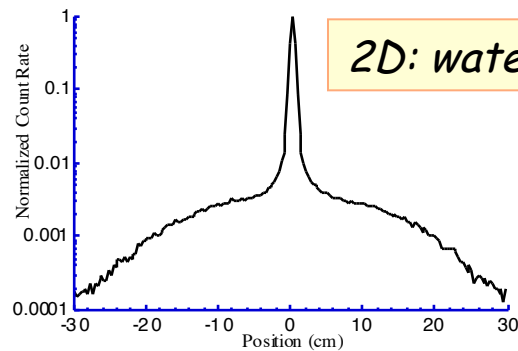
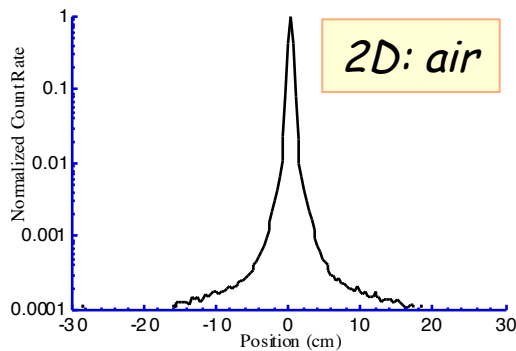

Corrections de diffusion en TEP

- Estimation of the number of the scattered photons by energy spectra study:
 - Double energy window
 - True coincidence estimation
- Estimation of the scattered photons from the projections:
 - Convolution
 - Profile approximation from outside the object
- Estimation of the scattered by calculating the distribution:
 - Analytical calculation
 - Simulation de Monte Carlo

Double Energy Window (DEW)

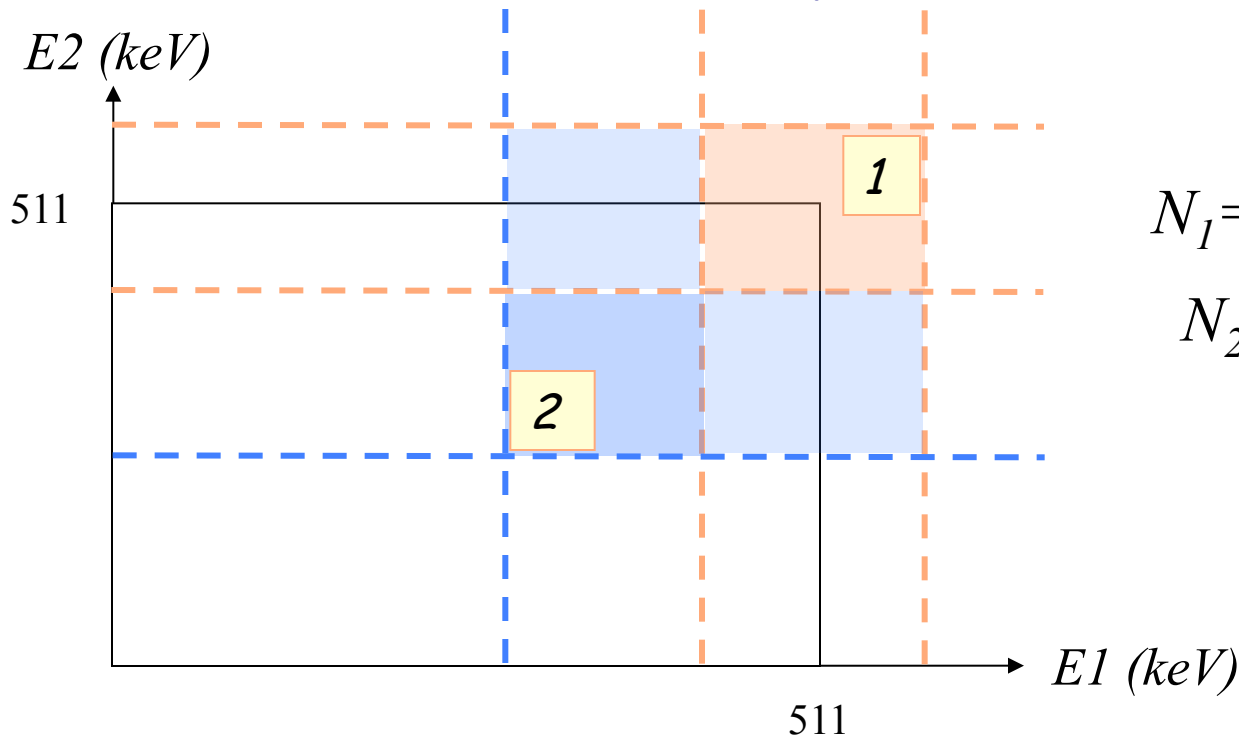

$$N_1 = N_{1_scattered} + N_{1_true}$$

$$N_2 = N_{2_scattered} + N_{2_true}$$

$$R_{diffuse} = \frac{N_{2_diffuse}}{N_{1_diffuse}}$$

$$R_{vrai} = \frac{N_{2_vrai}}{N_{1_vrai}}$$

Calibration

$$N_{1_diffuse} = \left[\frac{N_2}{R_{diffuse} - R_{vrai}} \right] - \left[\frac{N_1 \cdot R_{vrai}}{R_{diffuse} - R_{vrai}} \right]$$

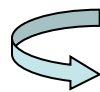

$$N_{1_vrai} = N_1 - N_{1_diffuse}$$

Scattered profile approximation

- Hypothesis:

- Events outside the object

- scatter distribution

- Image of scatter = Low frequency image

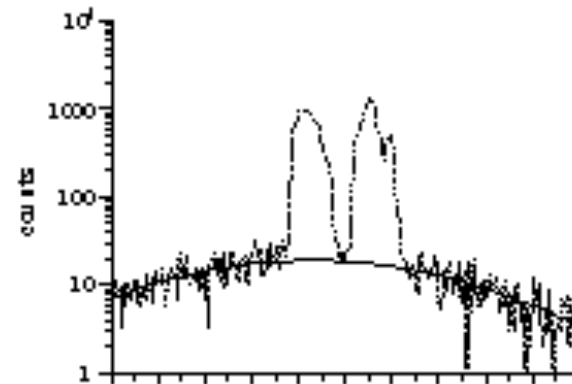
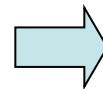
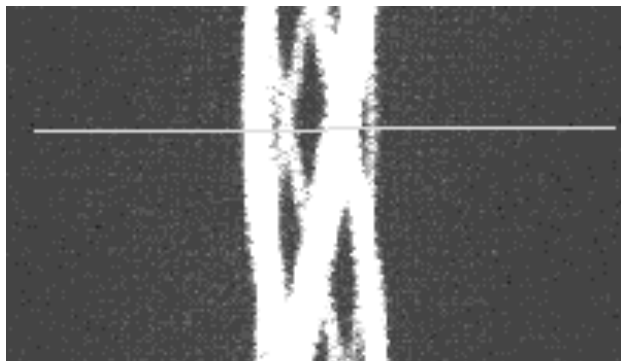

Distribution calculation

- Hypothesis:

- Known true events distribution
- Known transmission map

- Algorithm

Possible iteration

- *A* – Analytical calculation or Monte Carlo simulation of the scattered photons distribution.
- → Scattered sinogram
- *B* – Sinogram acquired - estimation of scattered sinogram
- → Sinogram corrected from scatter
- *C* – Image reconstruction
- → Estimation of the true events distribution

3D methods comparison

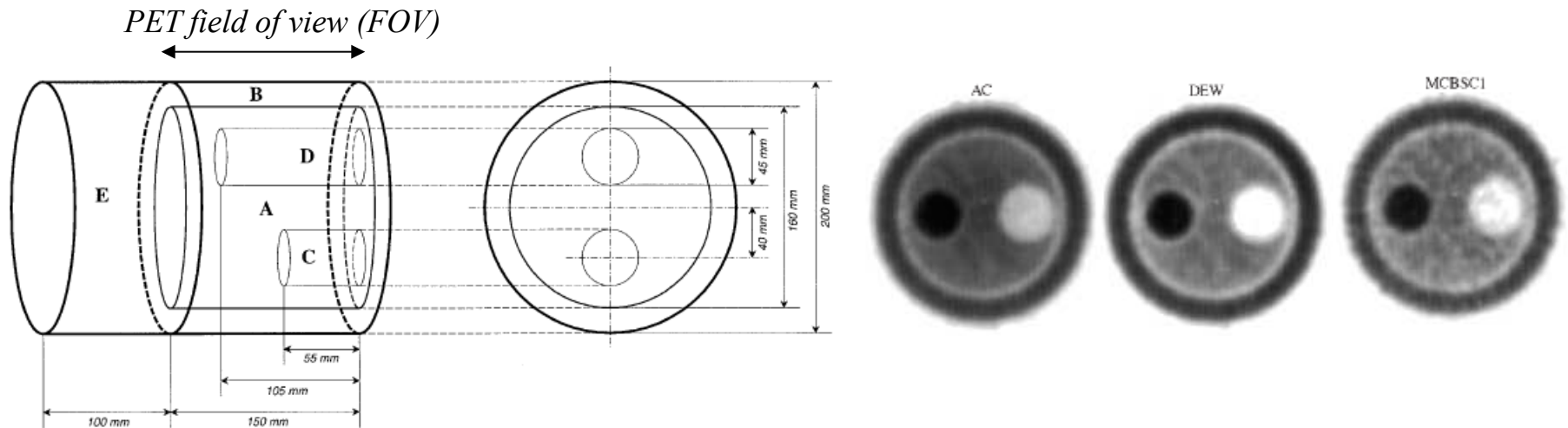

No activity outside the FOV

Figure of merit	Absolute concentration (kBq/ml)		Contrast (%)		SNR
	B	D	C	A	
Calibration concentration	5.88	4.86	100		-
AC	7.66±0.28	30% 5.31±0.17	9%	63.82±1.15	21.91±5.17
DEW	6.05±0.23	3% 4.62±0.18	-5%	91.63±1.84	15.42±3.64
CVS	6.49±0.30	4.68±0.23		84.11±3.85	18.79±4.54
SRBSC	6.52±0.30	4.76±0.22		86.26±3.95	19.46±4.72
MCBSC1	6.51±0.24	11% 4.81±0.21	-1%	81.31±3.93	9.74±2.43
MCBSC2	6.55±0.27	4.78±0.15		85.02±1.76	10.32±2.05

No correction
DEW

Monte Carlo

3D methods comparison

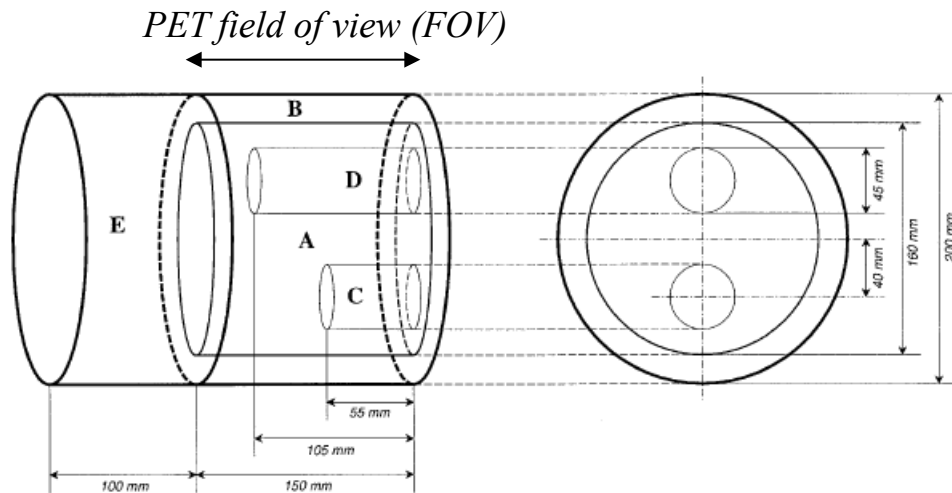

Activity outside of the FOV

Figure of merit	Absolute concentration (kBq/ml)		Contrast (%)		SNR	
	B	D	C	A		
Calibration concentration	5.88	4.86	10		–	
AC	7.94±0.30	35%	5.47±0.15	13%	64.60±1.08	19.04±4.69
DEW	6.14±0.21	4%	4.61±0.10	-5%	95.74±2.09	12.37±3.97
CVS	6.72±0.32		4.82±0.20		84.90±3.34	16.24±4.33
SRBSC	6.76±0.32		4.90±0.19		86.78±3.30	16.81±4.60
MCBSC1	6.62±0.31	13%	4.72±0.24	-3%	86.23±2.64	9.78±3.37
MCBSC2	6.77±0.24		4.94±0.18		86.33±1.54	9.33±2.33

*No correction
DEW*

Monte Carlo

Normalization correction

- Required correction:
 - No detection uniformity between different detectors.
 - Geometrical factors (curvature of the detection ring)
 - Dead zone in collected data

Each system line response should have the same detection efficiency

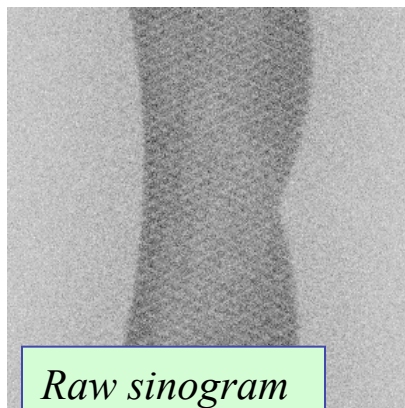

Normalisation coefficient
(NC)

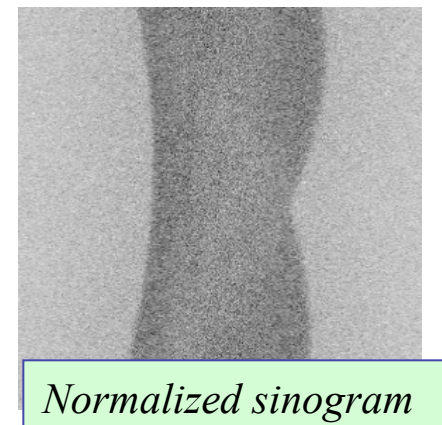

Normalisation coefficients

- Full flux acquisition
 - All lines of response are irradiated by the same source.
 - Require a high number of counts (important statistics).
- Modeling
 - $NC = \text{Crystal efficiency} \times \text{Geometrical factor}$

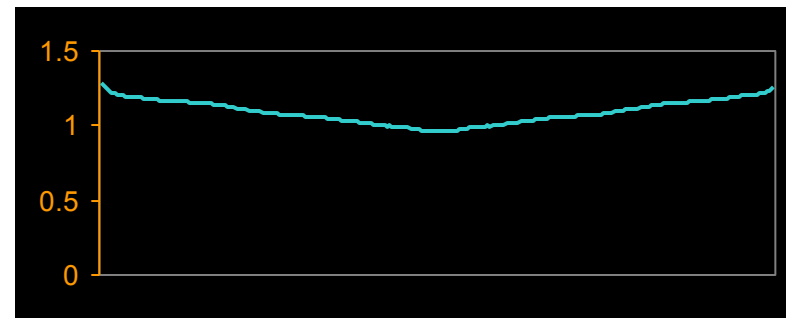
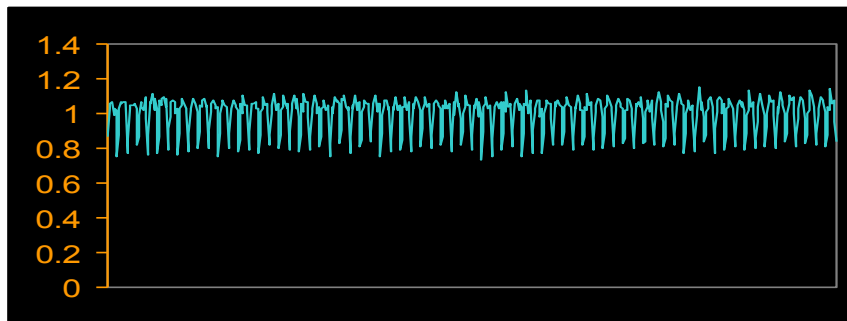
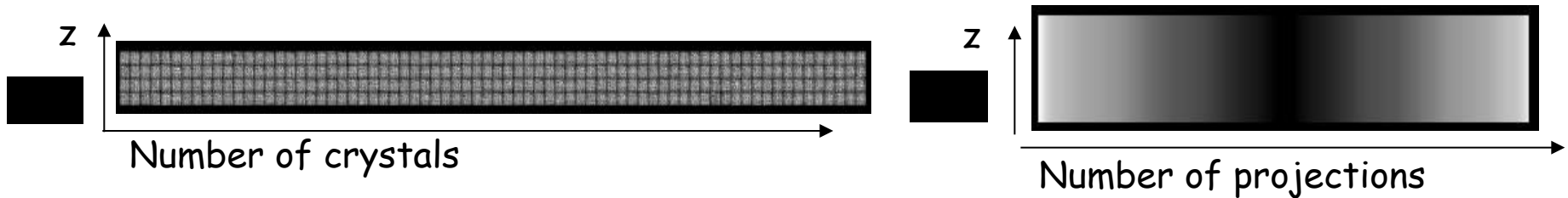

Obtaining the coefficients

$g(x) \times \text{crystal interference}(x \bmod 8)$

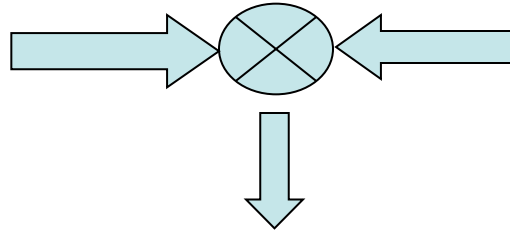
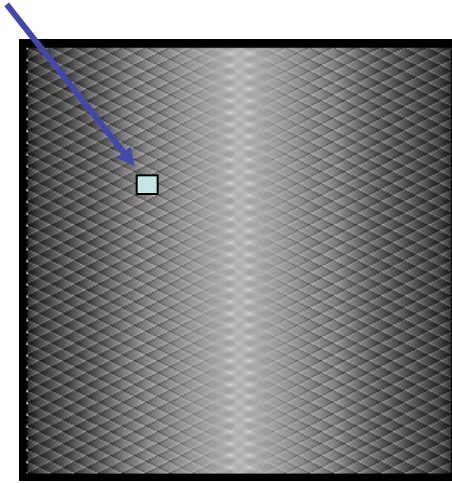

$e(\text{det}1) \times e(\text{det}2)$

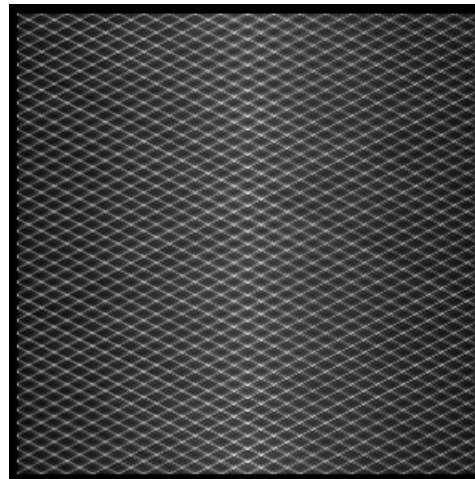
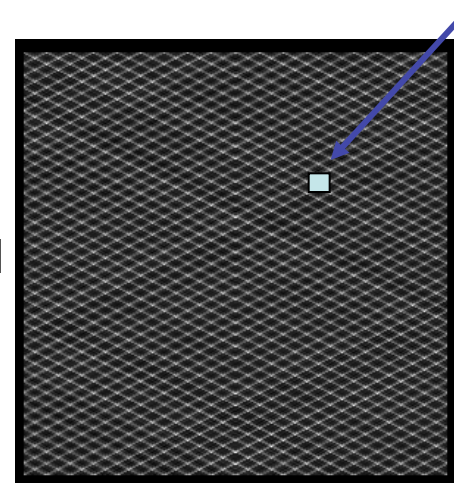

Random coincidences in PET

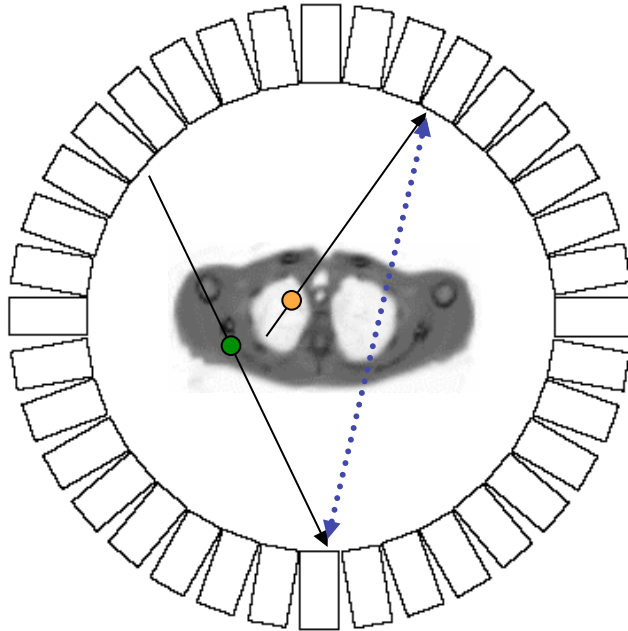

Detection solid angle of unique photon

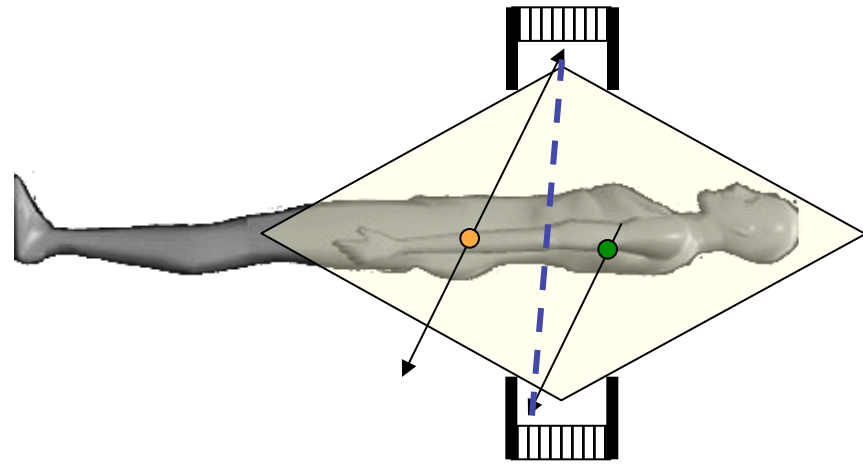

$$R_{ij} = 2\tau S_i S_j$$

- Random coincidences depend on:
 - Used time window
- Consequences of the random coincidences:
 - Bad localisation
 - A quantitatif bias

Correction of random coincidences

- Measurement of delayed coincidences
 - Utilisation of a delayed window

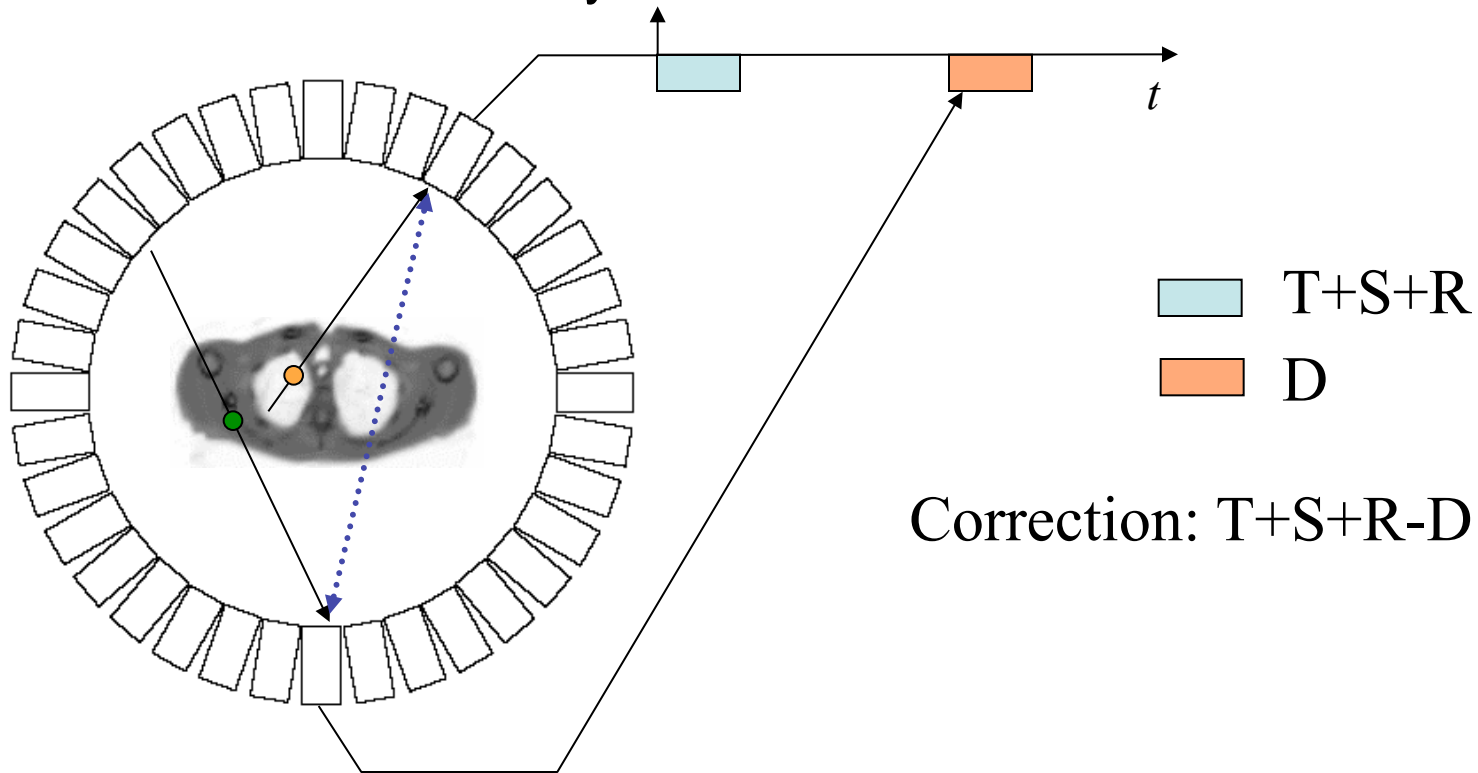

Correction of random coincidences

- Variance reduction
 - Smoothing of the random coincidences sinogram delayed with an appropriate methods.
 - Estimation of the sinogram of random coincidences fortuites from the measurement of simple photons.

$$R_{ij} = 2\tau S_i \varepsilon_i S_j \varepsilon_j$$

Simplex Normalisation

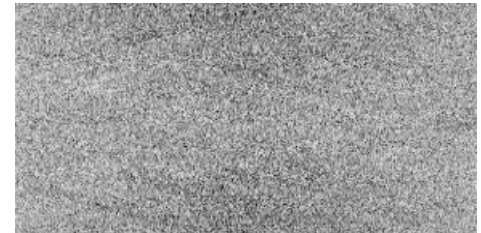

Noisy Sinogram

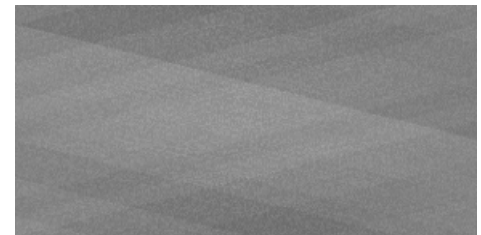
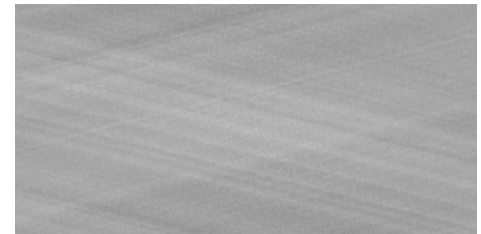

Question:

5 minutes whole body acquisition

Rate of measured coincidences = 50 000 cps

Rate of random coincidences = 20 000 cps

Acquisition in 3D mode with 10^6 LORs

Compare the two correction methods (noisy and not noisy) in terms of % $\Delta N_{\text{true}}/N_{\text{true}}$ per LOR

Hypothesis:

Scattered coincidences are negligible

True and random coincidences are distributed uniformly on all the LORs

Total number of coincidences per LOR: $50000 \times 300 / 10^6 = 15$

Number of random coincidences per LOR: $20000 \times 300 / 10^6 = 6$

Number of true coincidences per LOR: $15 - 6 = 9$

Noisy method

$$\Delta N_{\text{vraie}} = \sqrt{N_{\text{vraie}} + 2 \times N_{\text{fortuit}}} = \sqrt{9 + 12} = 4,58$$

$$100 \times \frac{\Delta N_{\text{vraie}}}{N_{\text{vraie}}} = 50,9\%$$

No Noisy method

$$\Delta N_{\text{vraie}} = \sqrt{N_{\text{vraie}} + N_{\text{fortuit}}} = \sqrt{9 + 6} = 3,87$$

$$100 \times \frac{\Delta N_{\text{vraie}}}{N_{\text{vraie}}} = 43\%$$

Quality image estimation

- How to estimate the image quality?
 - Based on the concepts of:
 - *Sensitivity: detection of true positives*
 - *Specificity: détection de false positives*
 - → *Receiver Operating Characteristics: represents the probability of detecting a true positive as function of detecting a false positive.*
 - *Difficult set up*
- Estimate the signal to noise ratio in the image:
Noise Equivalent Count Rate

Signal to noise ratio in the image

○ $SNR = k \frac{t_e}{\sqrt{VAR_e}}$

Number of true coincidences

Pixel variance

- A line of response registers the following signal:

$$(t_p + s_p + r_p) - (s_p + r_p)$$

True coincidences

Scattered Coincidences

Random coincidences

After corrections

Variance calculation

The variance of an image uncorrected from attenuation and dead time:

Weighting factor

$$VAR = \sum_m w_m (t_p + s_p + r_p)$$
$$VAR = \sum_m w_m t_p (1 + \alpha_{sp} + \alpha_{rp})$$

Number of projections

Hypothesis: Scattered and random coincidences correction does not increase the signal

After dead time and attenuation correction:

Correction factor

$$VAR_e = ac^2 \cdot VAR$$

Simplifying the problem

Analyse the pixel in the centre of the reconstructed image

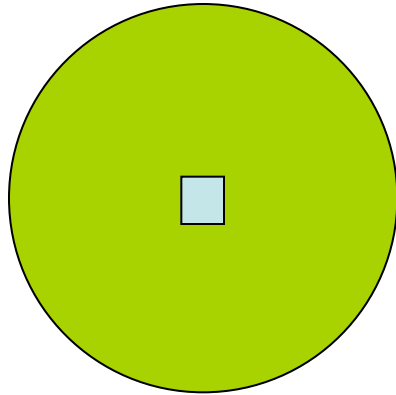

Cylindre corrected
From attenuation and dead time

Number of true coincidences
Per line of response

Cylindre diameter

Number of true coincidences
In the pixel

$$t_p = \frac{D \cdot t_e}{d \cdot m \cdot ac}$$

Pixel size

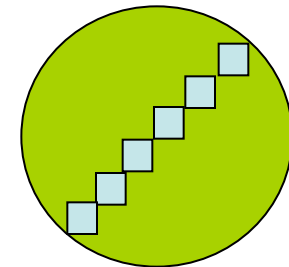

Number of coincidences in a pixel

Number of true coincidences
In the whole image without correction

$$t_e = T \cdot \text{moy}(ac) \cdot \frac{d^2}{\frac{\pi}{4} D^2}$$

$$VAR_e = ac^2 \cdot VAR$$

$$SNR = k \frac{t_e}{\sqrt{VAR_e}}$$



$$SNR = k \cdot \sqrt{\frac{4}{\pi}} \left(\frac{d}{D} \right)^{\frac{3}{2}} \sqrt{\frac{\text{moy}(ac)}{ac}} \sqrt{\frac{T}{1 + \alpha_{sp} + \alpha_{rp}}}$$

$$t_e = T \cdot \text{moy}(ac) \cdot \frac{d^2}{\frac{\pi}{4} D^2}$$

Noise Equivalent Count

$$NEC \approx SNR^2$$

$$SNR = k \cdot \sqrt{\frac{4}{\pi}} \left(\frac{d}{D} \right)^{\frac{3}{2}} \sqrt{\frac{moy(ac)}{ac}} \sqrt{NEC}$$

$$NEC = \frac{T}{1 + \alpha_{sp} + \alpha_{rp}}$$

True coincidences in the image
Fraction for a line of response

Reminder

Hypothesis: Corrections of random and scattered coincidences do not introduce noise

In presence of noise,

	<i>Signal</i>	<i>Variance</i>
Random coincidences:	$t_p + s_p + r_p - r_p$	$t_p + s_p + (1 + \beta) f_{FOV} r_p$
Scattered coincidences:	$t_p + s_p + r_p - r_p - \alpha_{cp} (t_p + s_p)$	$t_p + s_p + \beta r_p + \alpha_{cp}^2 (t_p + s_p + (1 + \beta) f_{FOV} r_p)$ $(1 + \alpha_{cp}^2) (t_p + s_p + (1 + \beta) f_{FOV} r_p)$

Noise Equivalent Count

$$NEC = \frac{T}{1 + \alpha_{sp} + \alpha_{rp}}$$

$$NEC = \frac{T}{(1 + \alpha_{cp}^2)(t_p + s_p + (1 + \beta)f_{FOV}r_p)}$$

The X_i are approximations of X_p in the image

$$NEC = \frac{T^2}{(1 + \alpha_{ci}^2)(T + S_i + (1 + \beta)f_{FOV}R_i)}$$

The more often, $\alpha_{ci} = 0$ because the scattered correction does not introduce noise

$$NEC = \frac{T^2}{(T + S_i + (1 + \beta)f_{FOV}R_i)}$$

Application example: Random correction methods comparison

TEP HR+

Detector size (mm)	4.0 x 4.1 x 30
No. of slices	63
Slice width (mm)	2.4
Ring diameter (cm)	82.7
Axial FOV (cm)	15.2
Max. axial angle	10.2°
Mode	2D/3D



23 patients (13m, 10f)
(170 ± 10) cm
(76 ± 16) kg

Dose distribution,
1h after injection of $[^{18}\text{F}]\text{-FDG}$

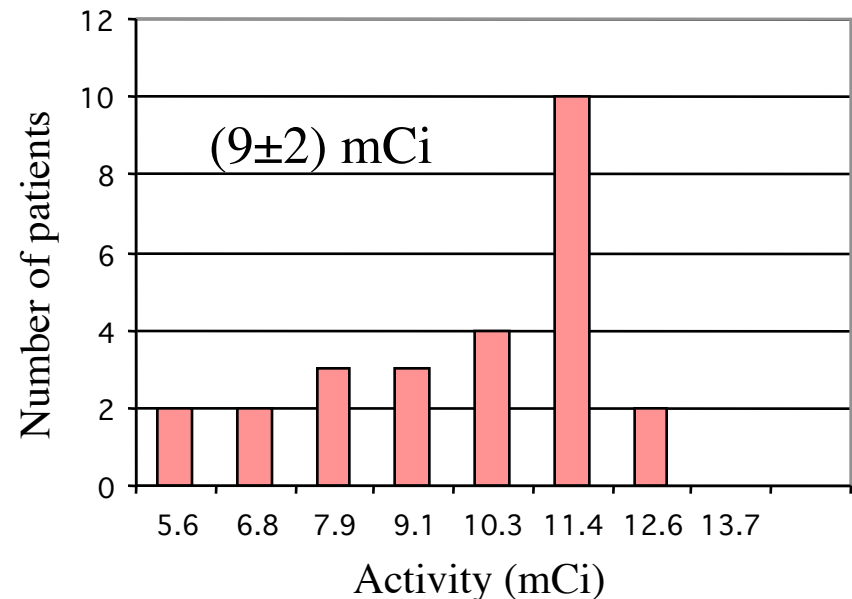

Methods comparison

Count rate per bed position

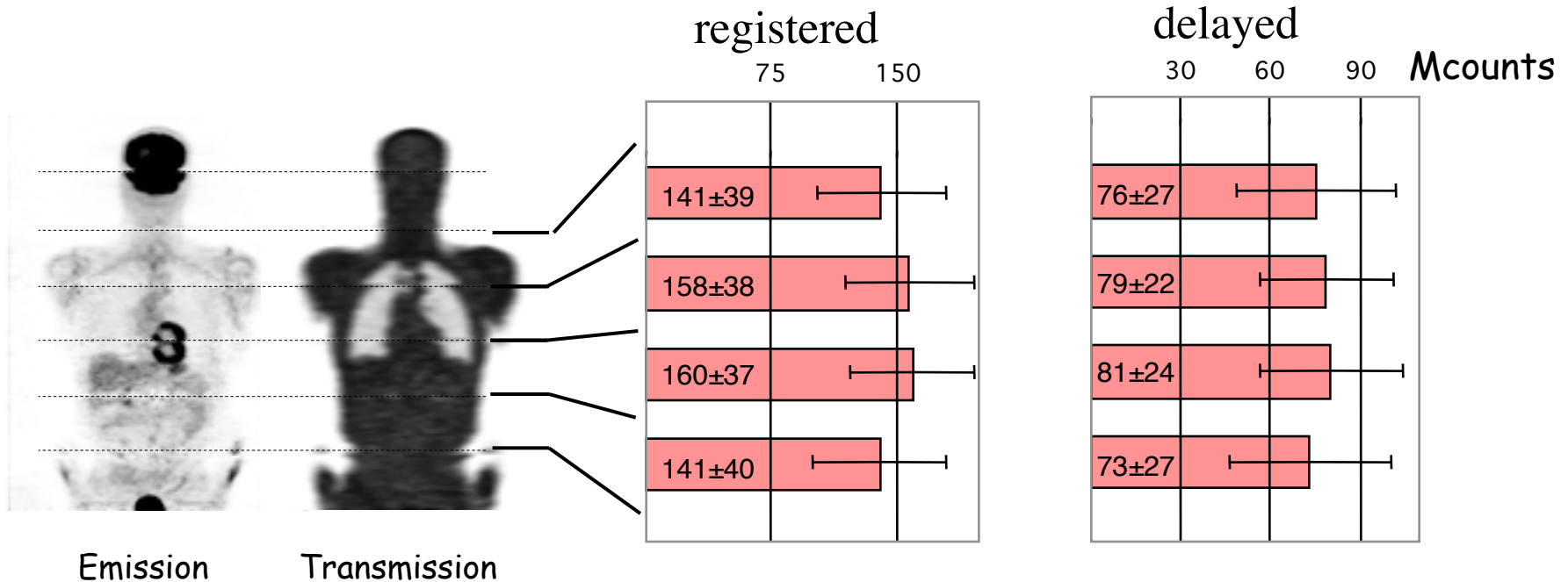

Methods comparison

Relative improvement of NEC:

$$\Delta NEC = 100 \cdot \frac{NEC_{\text{Noiseless}} - NEC_{\text{Online}}}{NEC_{\text{Online}}}$$

$$\Delta NEC(k) = \sqrt{1 + \frac{1-k}{1+k + \frac{T+S}{f_{FOF}R}}} - 1$$

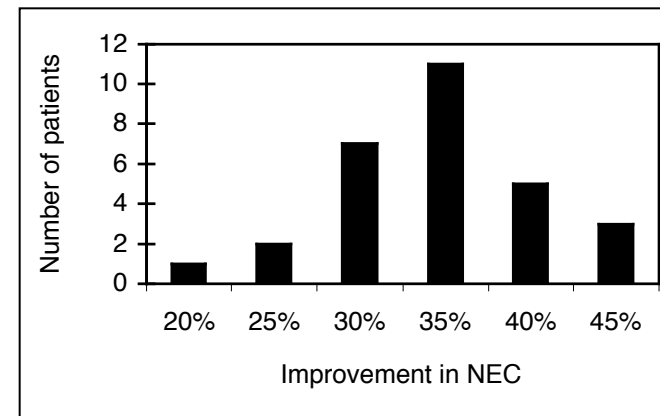
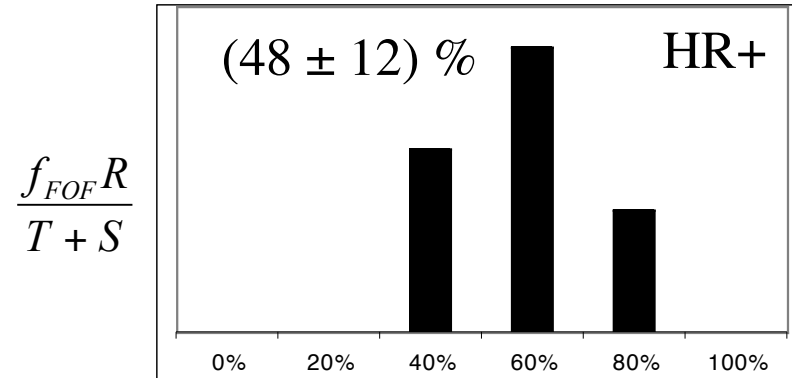
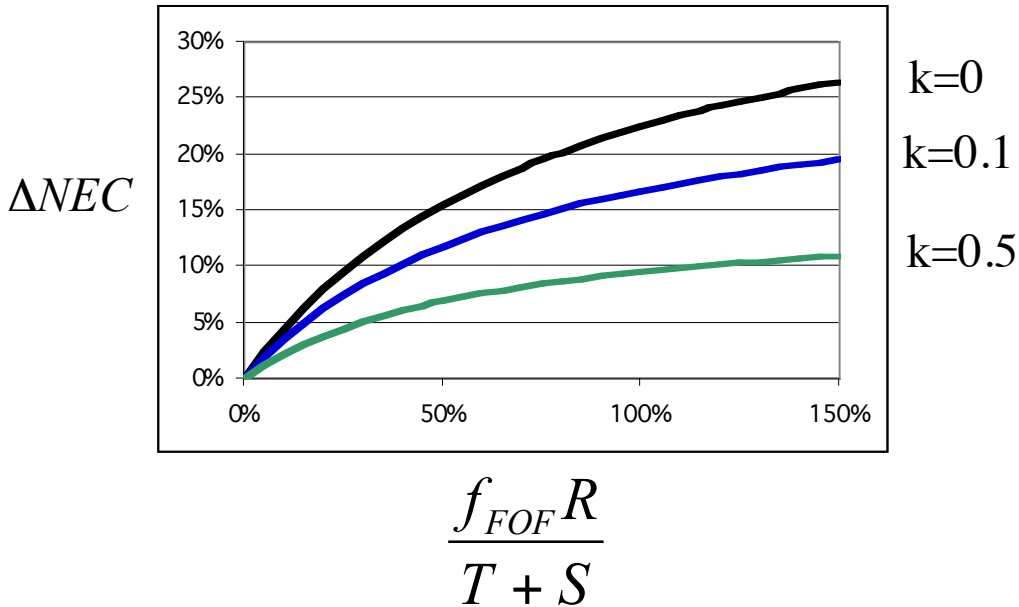

In summary

TABLE 1
Methods for Estimating Random Coincidences

Method	Comments
Delayed coincidences	Accurate. Higher noise (Eq. 1). Lowest processing requirements.
Smoothed delayed coincidences	Accurate. Lower noise ($0 \leq k \ll 1$, Eq. 1). Higher processing requirements.
Calculated from single photon rates	Potential for bias if scanner is not properly calibrated. Lower noise ($0 \leq k \ll 1$, Eq. 1). Low processing requirements.

Variance reduction used with high $\frac{f_{FOF} R}{T + S}$

Crystal choice

