

그리드 보안 기술

2015. 2. 3

Contents

- 01 개요
- 02 기초암호
- 03 X.509 PKI
- 04 SSL/TLS
- 05 결론

1. 개요

What is Security Threat Grid Computing?

The screenshot shows the MonALISA Repository for ALICE web interface. The browser address bar displays `alimonitor.cern.ch/map.jsp`. The page features a navigation menu with items like "My jobs", "My home dir", "Catalogue browser", "LEGO Trains", "Administration Section", "ALICE Reports", "Alert XML Feed", "Firefox Toolbar", and "MonaLisa GUI".

On the left, the "ALICE Repository" sidebar lists various views and information categories. The main content area displays a satellite map of Europe with numerous site locations marked by colored dots and labels, including CERN sites like CERN, SPbSU, PNNI, and others. A central graphic shows a laptop with a magnifying glass over a hacker icon, symbolizing security monitoring. The word "Resources" is partially visible in large orange text on the right side of the map.

Characteristics of Grid Computing Environment

- Large & dynamic user population and resources pool
- Dynamic resource acquisition and release
- Dynamic creation and destruction of a variety of network connection
- An individual user will be associated with different local name spaces, credentials, or accounts at different sites

e.g. Security Architecture in Globus

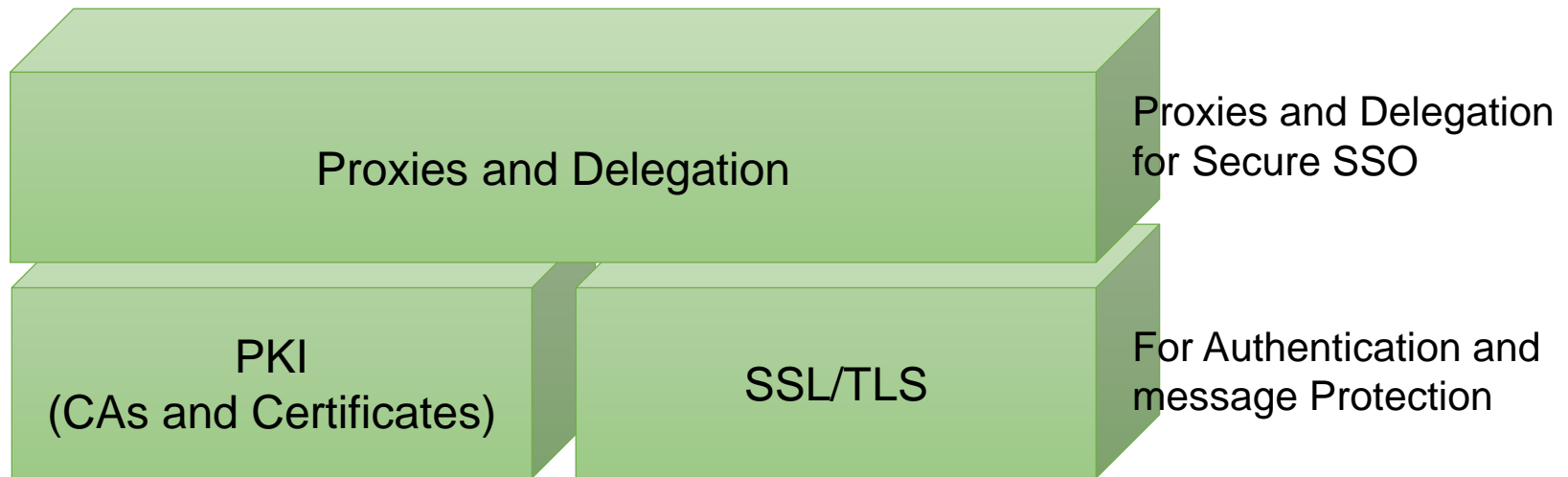

- SSO: Single Sign-On
- PKI: Public Key Infrastructure
- CA: Certification Authority
- SSL: Secure Socket Layer
- TLS: Transport Layer Security

In This Class, we are going to..

understand mechanisms
behind security process

보안의 목표

기밀성(Confidentiality)

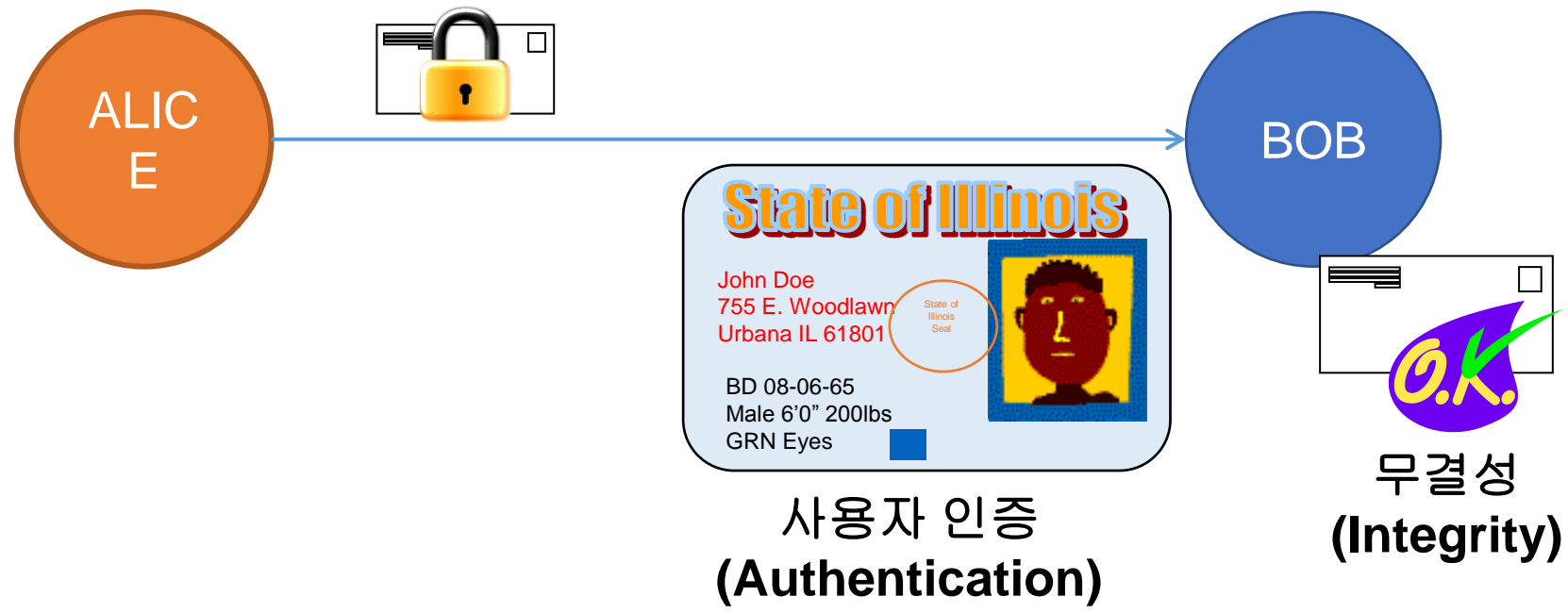

보안의 목표

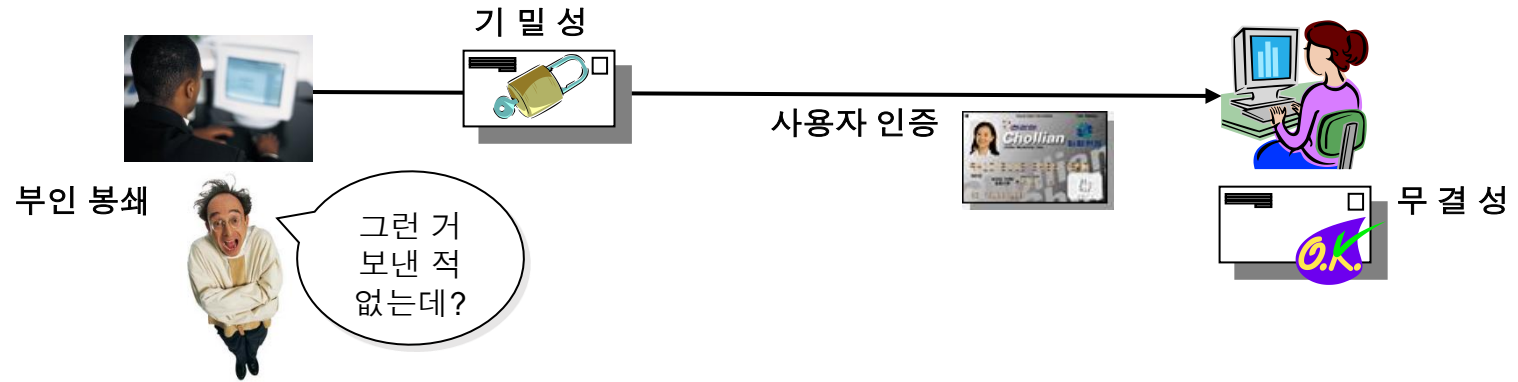

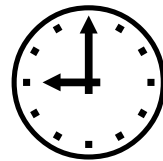
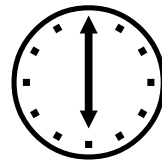
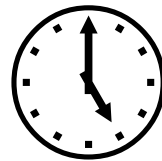
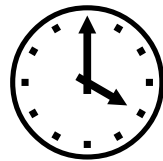
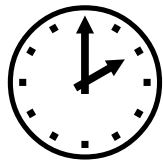
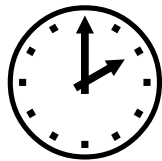
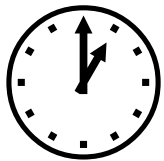

2. 기초 암호

If he had anything confidential to say, he wrote it in cipher, that is, by so changing the order of the letters of the alphabet, that not a word could be made out. If anyone wishes to decipher these, and get at their meaning, he must substitute the fourth letter of the alphabet, namely D, for A, and so with the others.

—[Suetonius](#), [Life of Julius Caesar](#)

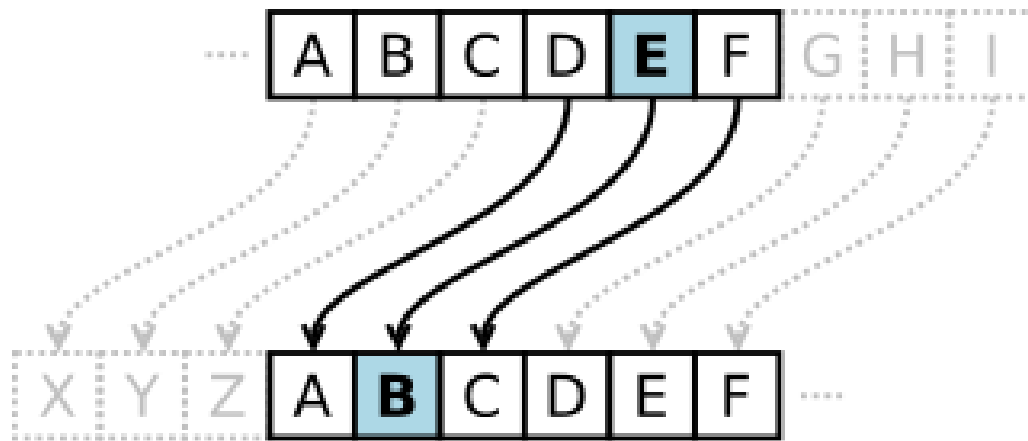
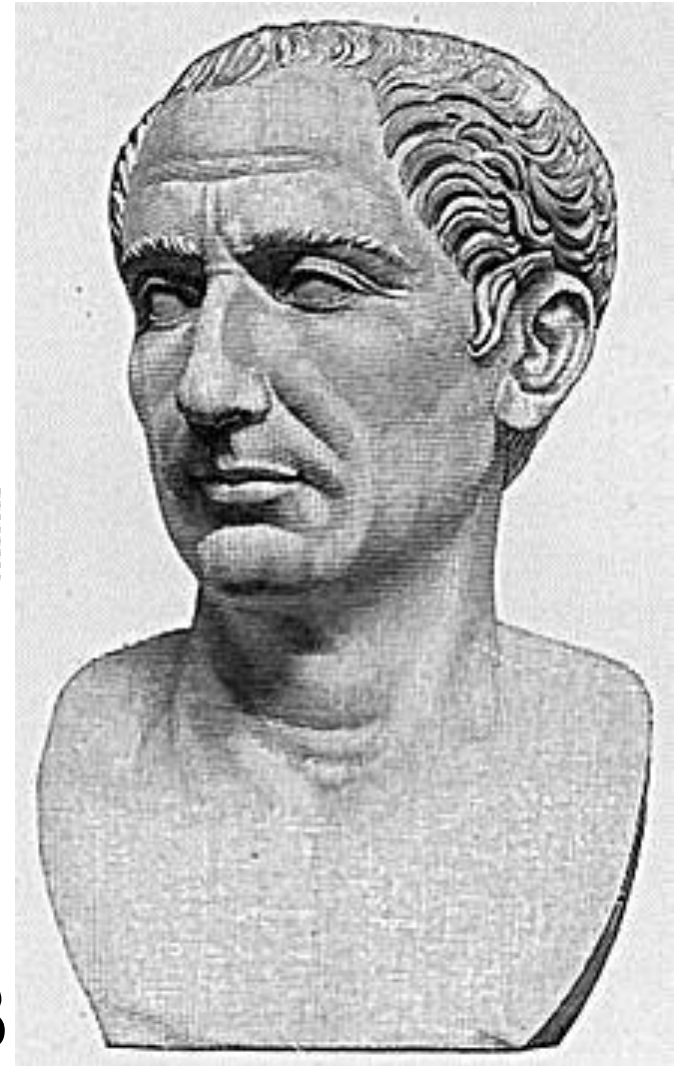

LOVE → (Shift 4) ILSB

평문

암호 알고리즘 암호키

암호문

Conventional Cryptography Symmetric Cryptography One-key Cryptography

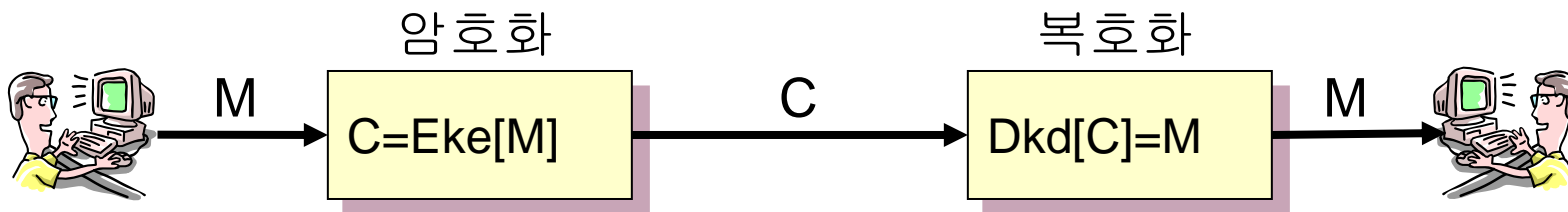

M: 평문

E: 암호화 알고리즘

C: 암호문

Ke: 암호화 키

D: 복호화 알고리즘

Kd: 복호화 키

- $K_e = K_d$
- 송신자와 수신자 사이의 공통의 키
- AES, DES, Skipjack, IDEA, FEAL, LOKI, GOST, SEED

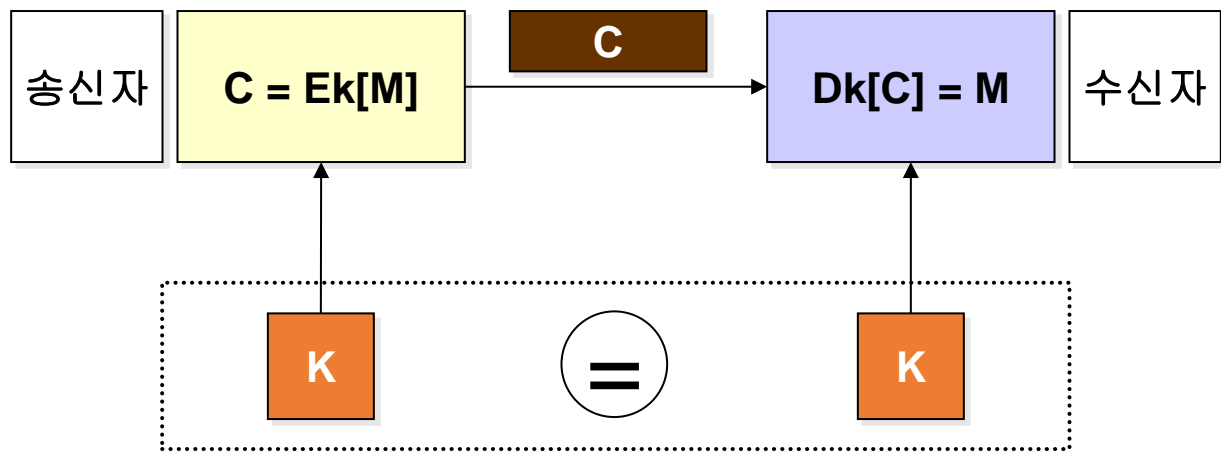

Block Cipher

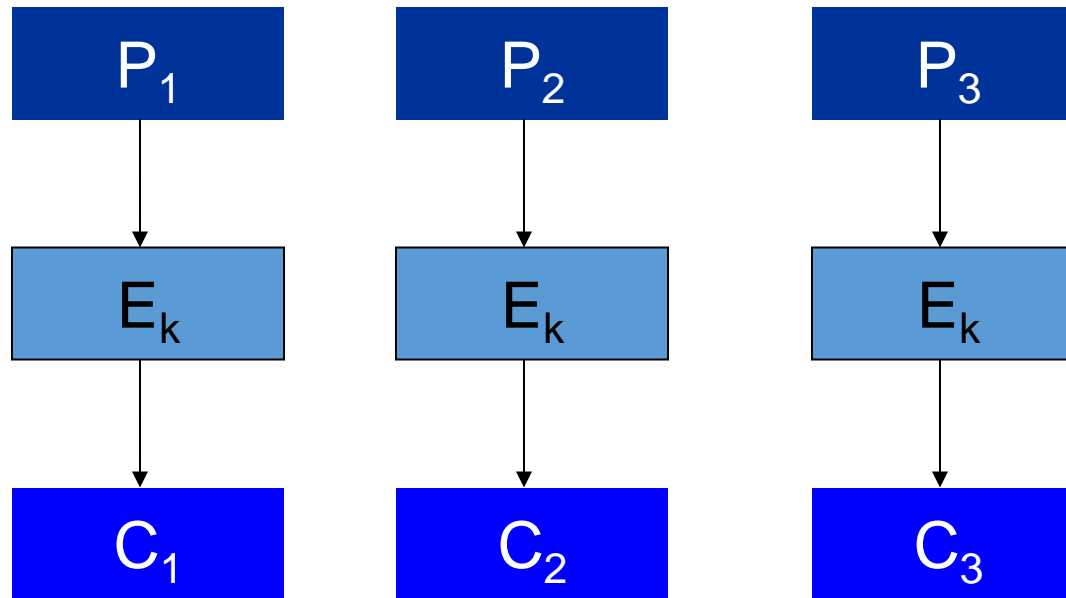

encrypt each plaintext block separately

Stream Cipher

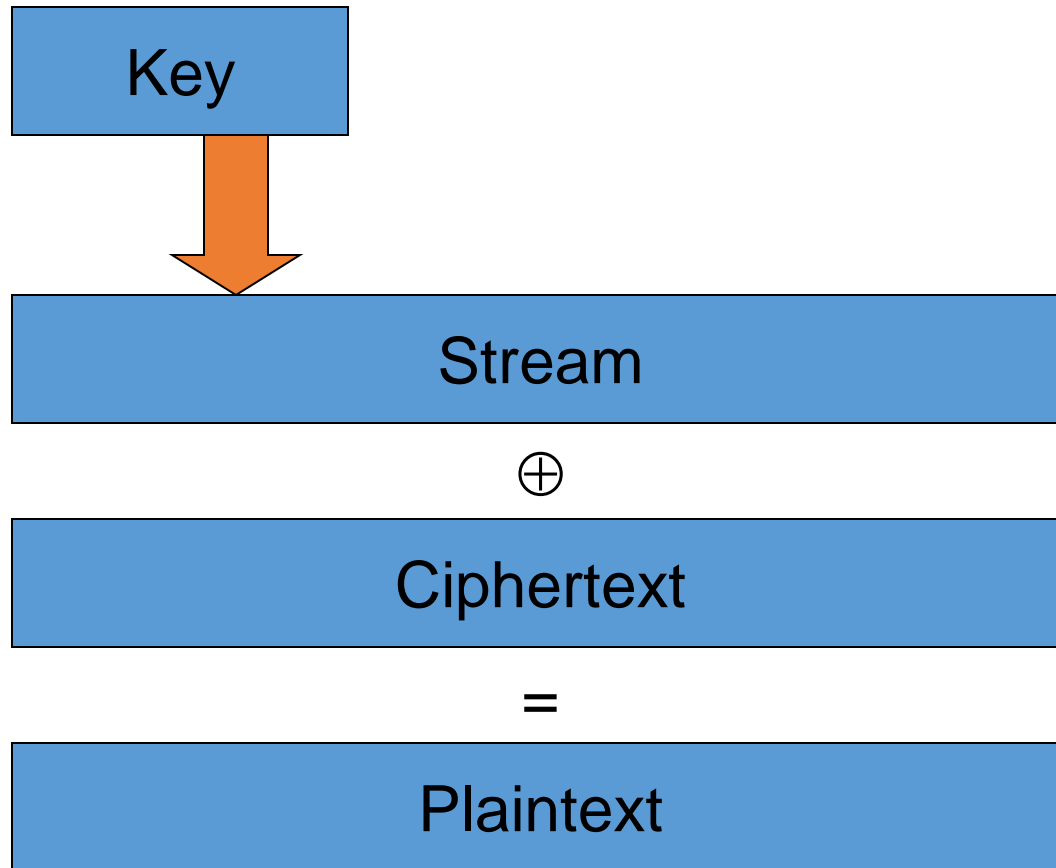

블록 암호 예제 - 시저 암호

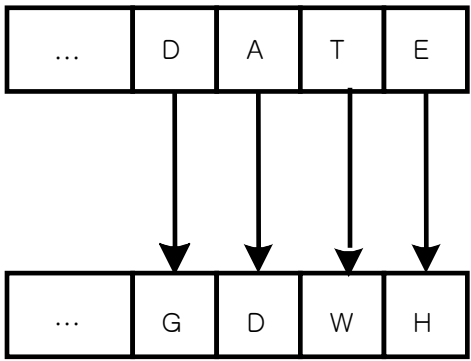
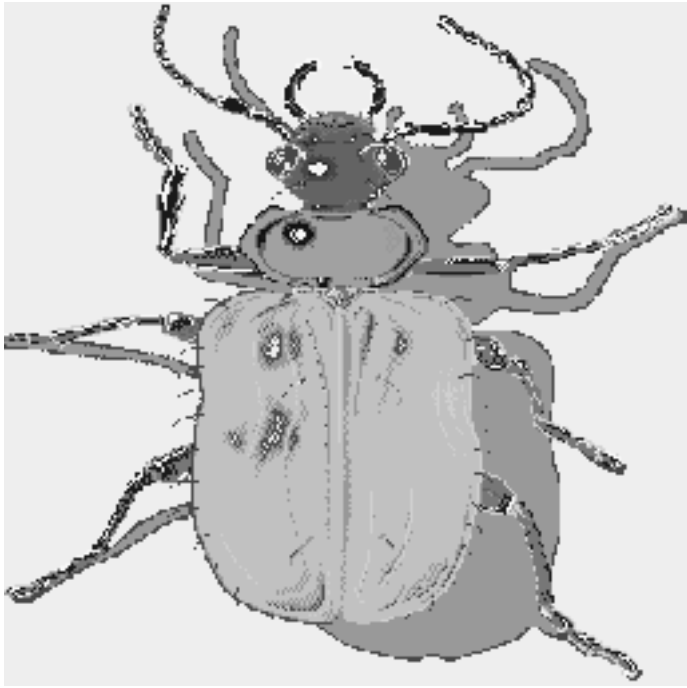
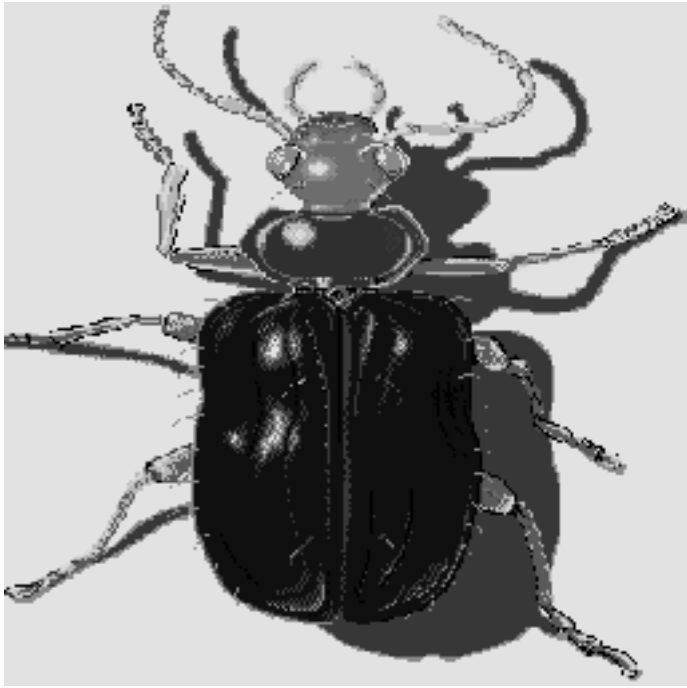

각 바이트를 치환표에 의하여 암호화

블록 암호 예제 - Electronic Code Book

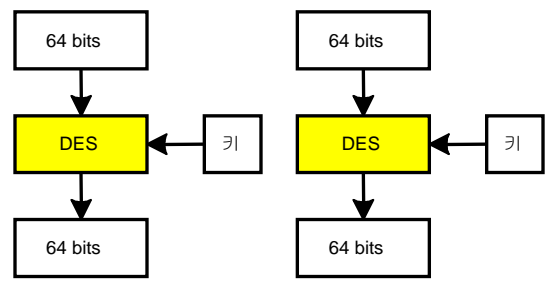
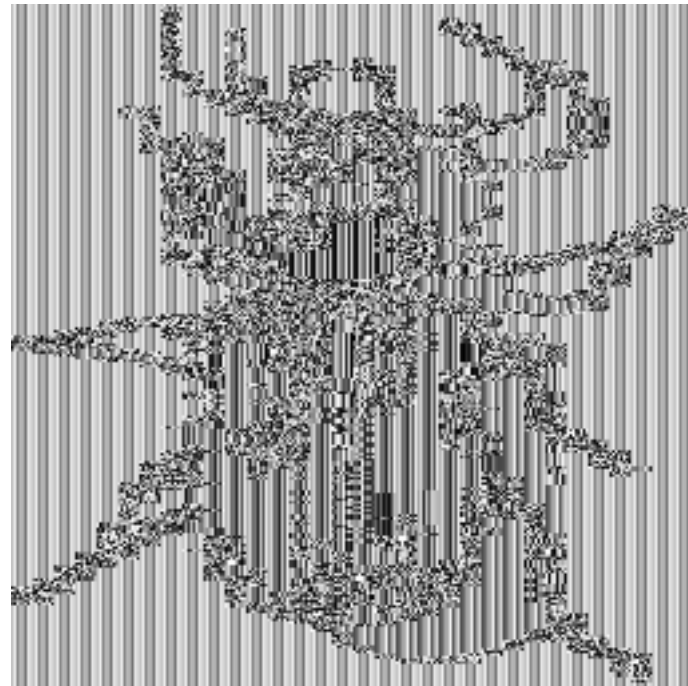
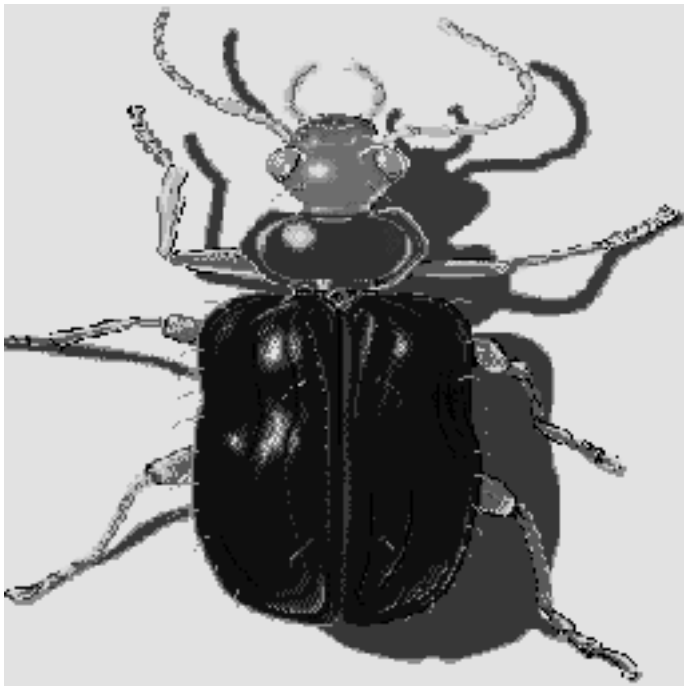

64비트 블록으로 나누어
각각을 암호화

블록 암호 예제 – Cipher Block Chaining

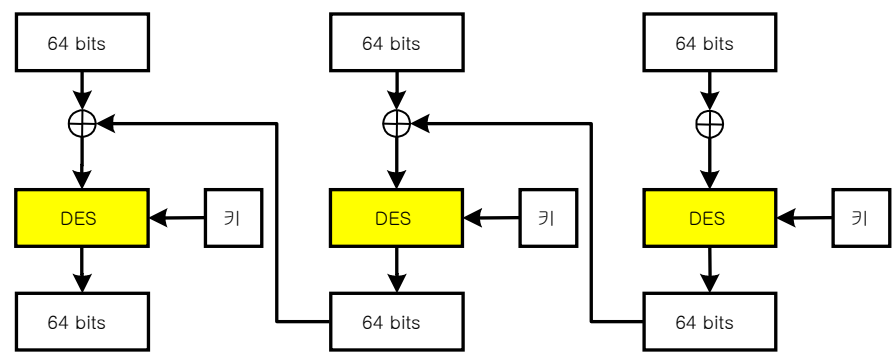
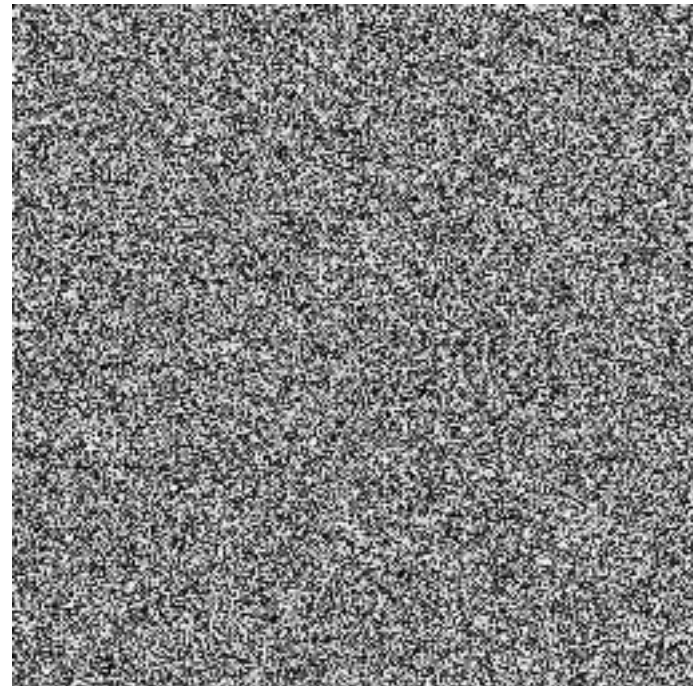
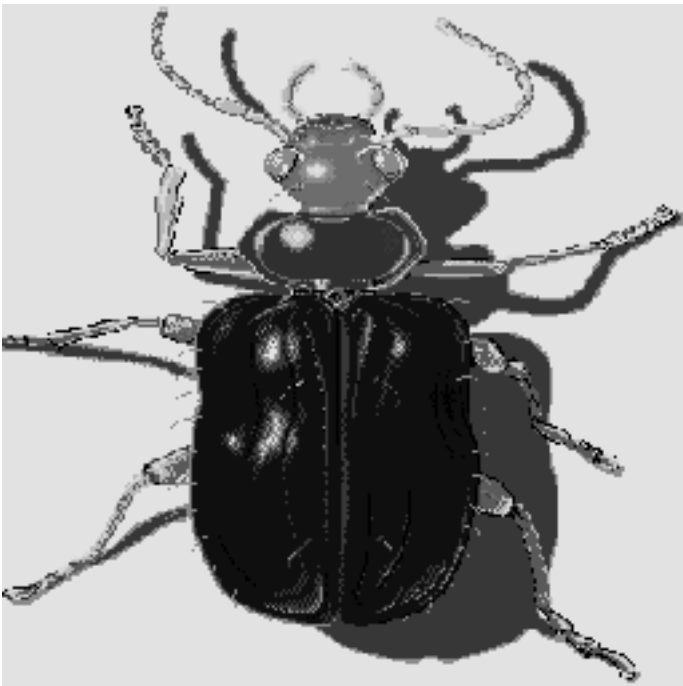

전단계의 암호문 블록이
다음 단계의 입력에 관여함

Enigma (2차 세계대전에서 독일군 사용)

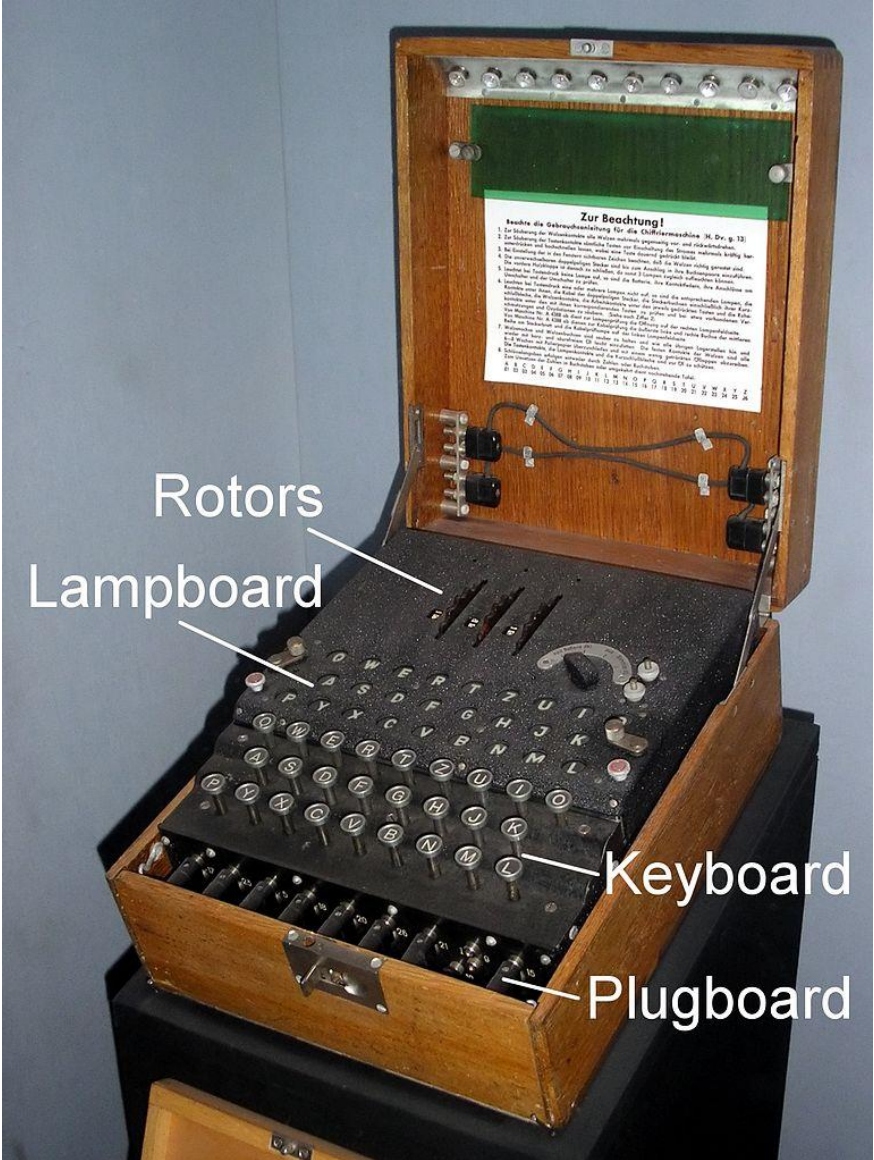

DES – Data Encryption Standard

- Designed by IBM, with modifications proposed by the National Security Agency
- US national standard from 1977 to 2001
- De facto standard
- Block size 64 bits;
- Key size 56 bits
- 16-rounds
- Designed mostly for hardware implementations
- Considered insecure now
 - vulnerable to brute-force attacks

Attacking Block Ciphers

- Types of attacks to consider
 - **known plaintext**: given several pairs of plaintexts and ciphertexts, recover the key (or decrypt another block encrypted under the same key)
 - **how would chosen plaintext and chosen ciphertext work?**
- Standard attacks
 - exhaustive key search
 - dictionary attack
 - differential cryptanalysis, linear cryptanalysis
- Side channel attacks.

DES's main vulnerability is short key size.

DES 해독기

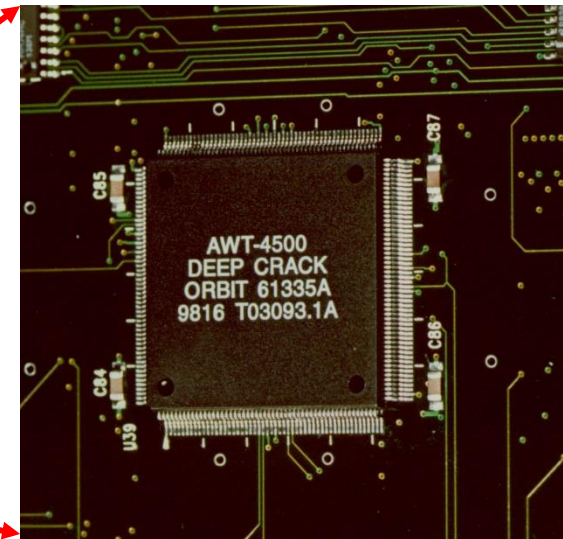
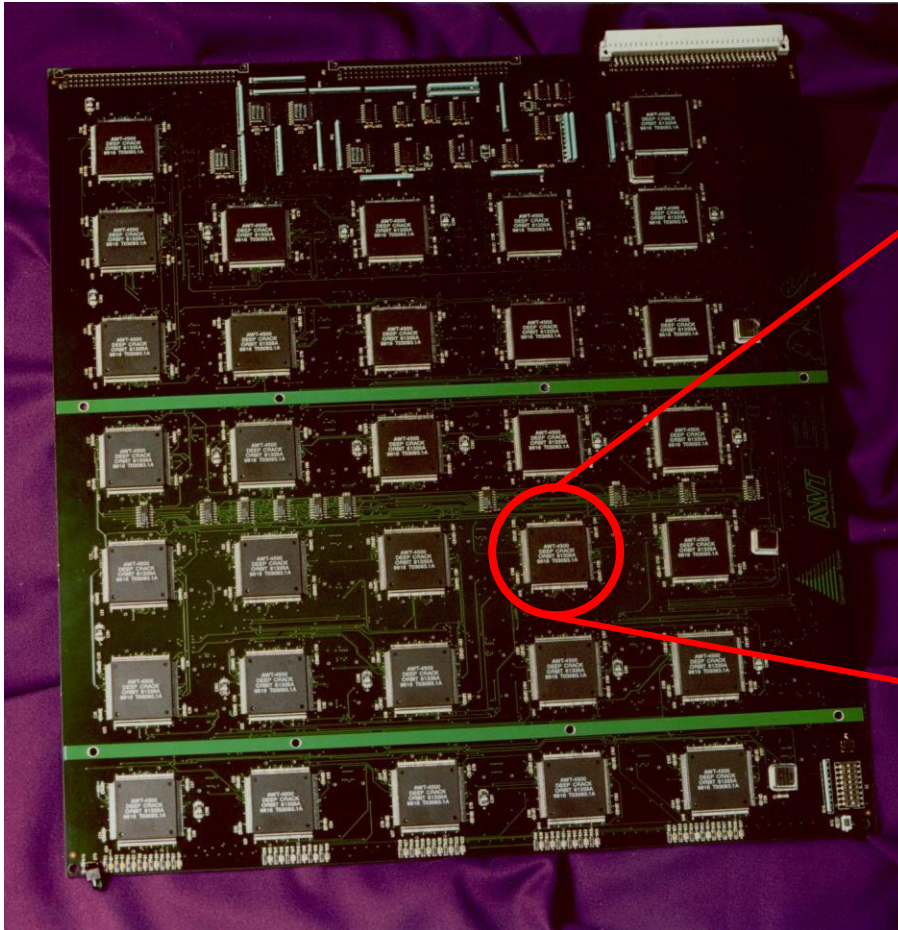

AES – Advanced Encryption Standard

- In 1997, NIST made a formal call for algorithms stipulating that the AES would specify an **unclassified, publicly disclosed encryption algorithm, available royalty-free, worldwide.**
- Goal: replace DES for both government and private-sector encryption.
- The algorithm must implement symmetric key cryptography as a block cipher and (at a minimum) support **block sizes of 128-bits and key sizes of 128-, 192-, and 256-bits.**
- In 1998, NIST selected 15 AES candidate algorithms.
- On October 2, 2000, NIST selected **Rijndael** (invented by Joan Daemen and Vincent Rijmen) to as the AES.

관용키 암호 알고리즘의 문제점

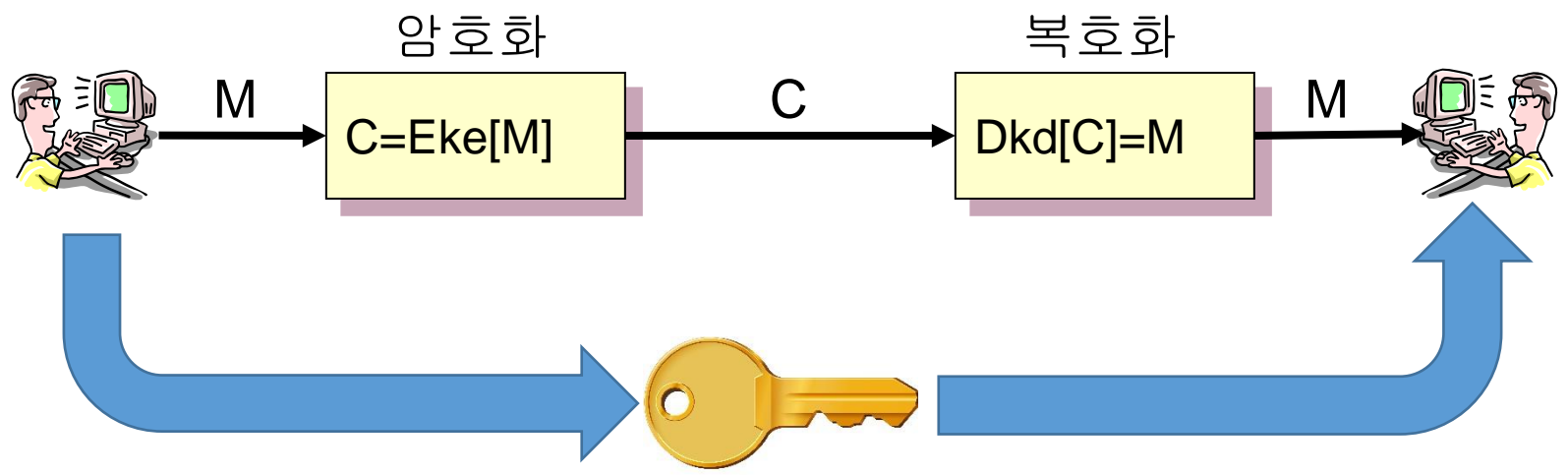

공개키 암호 알고리즘(Public Key Cryptography)

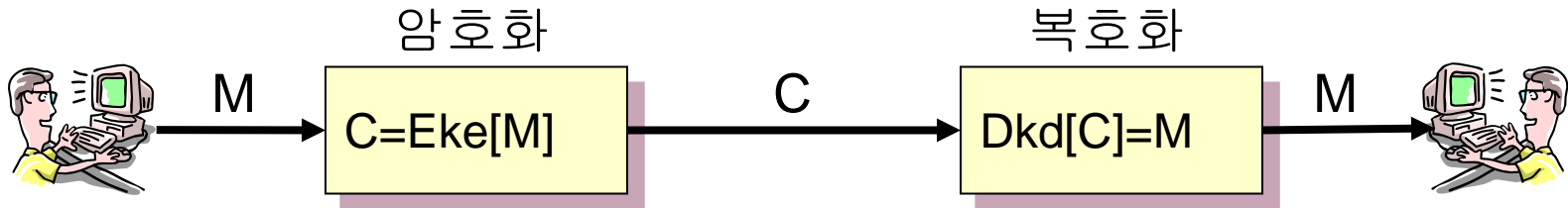

A



A의 비밀키

A의 공개키



B



B의 비밀키

B의 공개키



B의 공개키



A의 공개키

기밀성

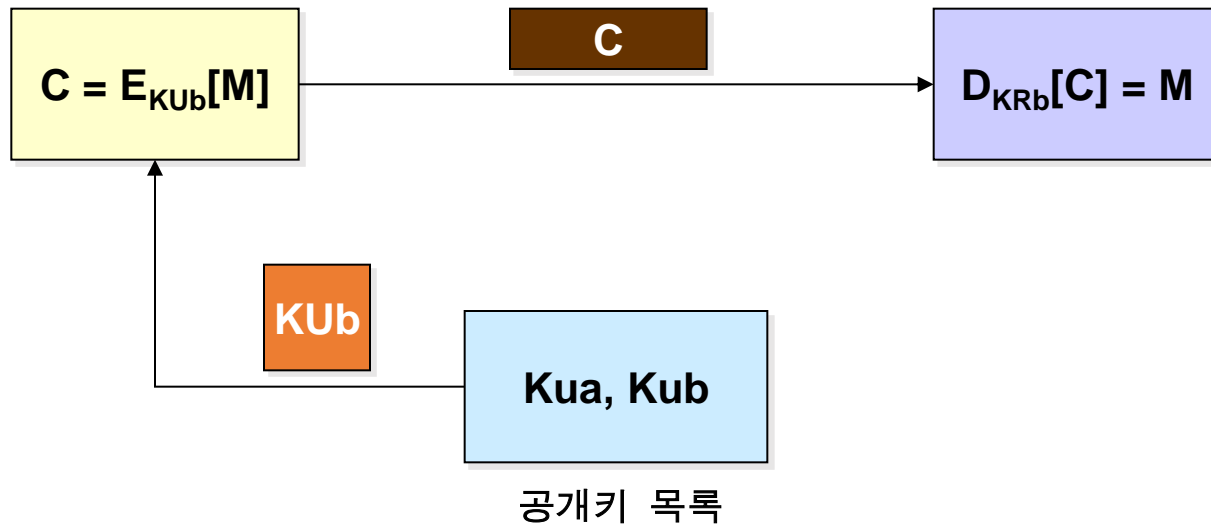

전자서명(Digital Signature)

- 제공 기능



- 요구 조건

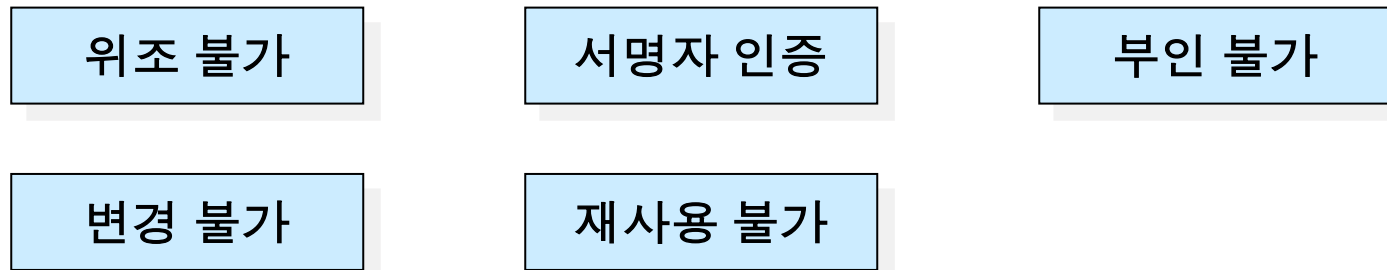

전자서명 생성 I

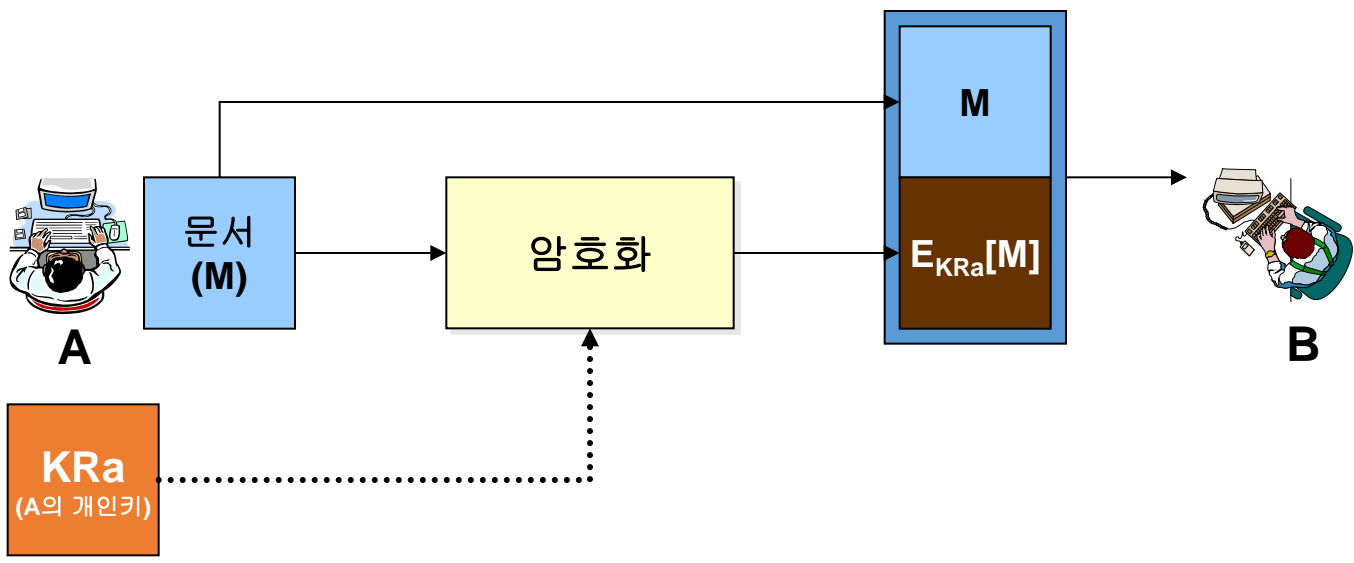

• 전자서명 확인 I

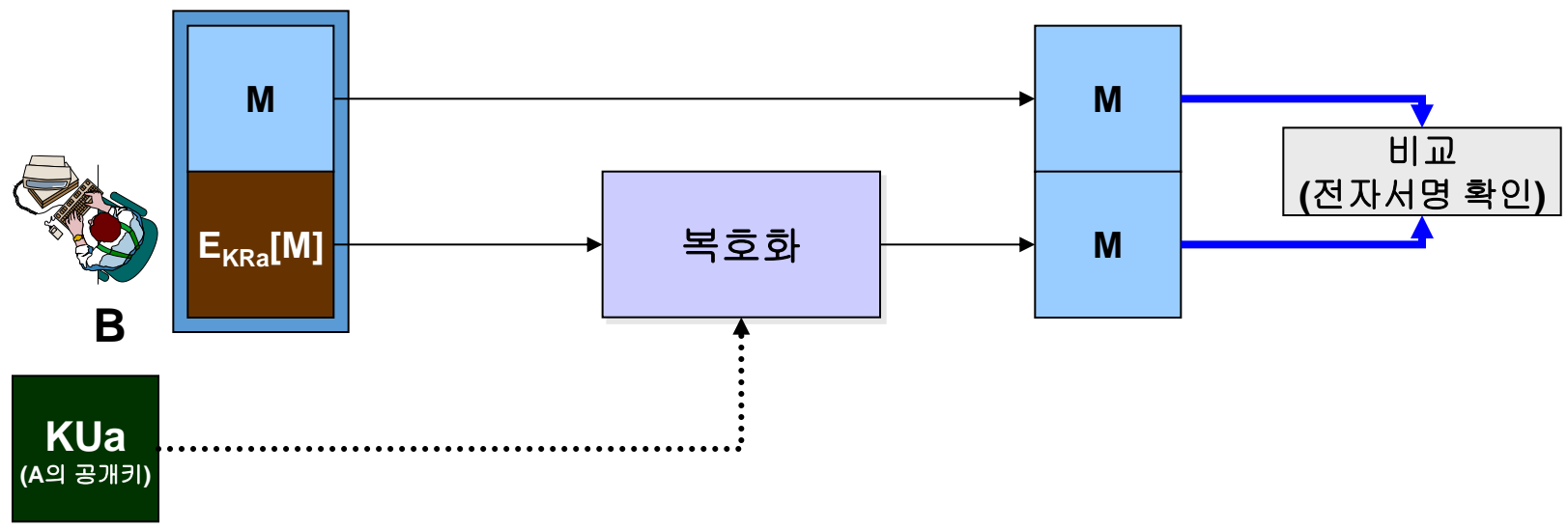

• 해쉬 함수

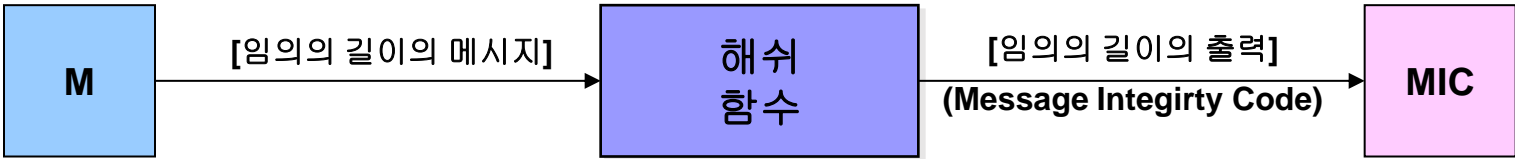

- 메시지에서 출력을 계산하는 것은 용이
- 출력으로부터 메시지를 계산하는 것은 계산상 불가능
- 서로 같은 해쉬값을 갖는 두 메시지를 찾는 것은 계산상 불가능

↳ 메시지 인증과 전자서명의 효율을 높이기 위해 사용

전자서명 생성 II

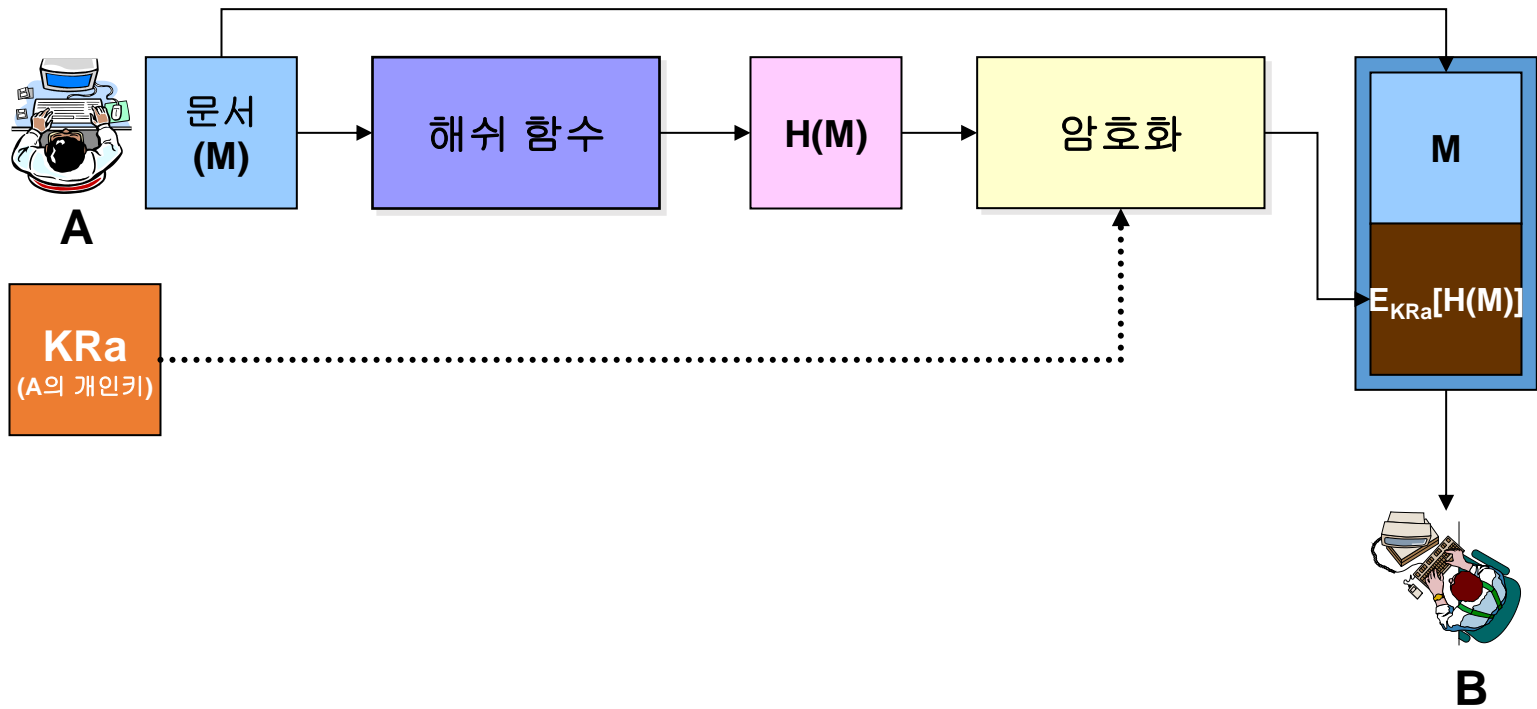

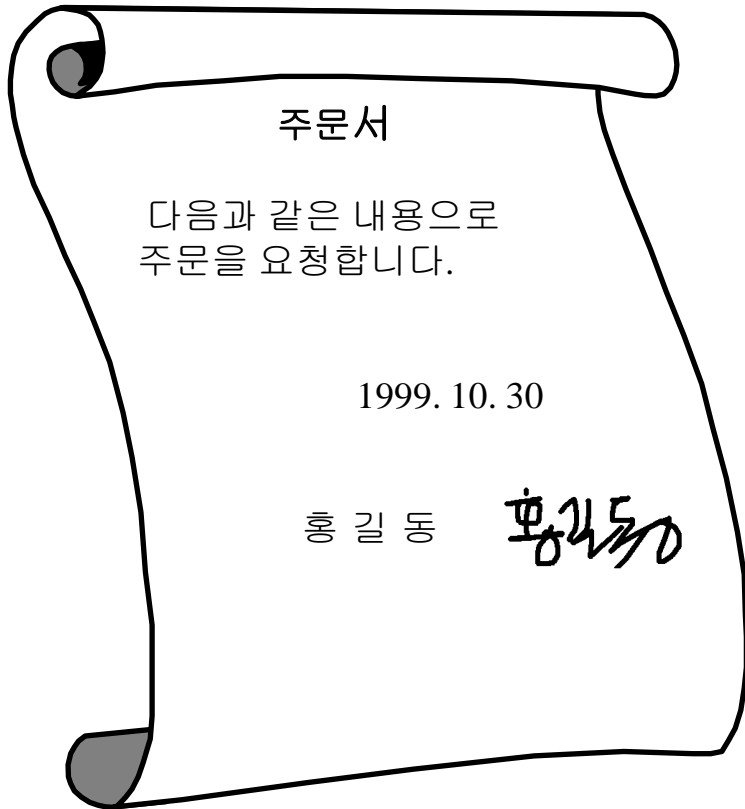

```
주문서

다음과 같은 내용으로 주문을 요청합니다.

1999.10.30

홍길동

-----BEGIN Digital Signature -----
Content-Type: application/x-pkcs7
                -signature;
Content-Disposition: attachment;
Content-Transfer-Encoding: base64

ggM7oAMCAQICFEQ41iugpRpD1VzRmFQZQnk
TWVtZSBSb290IENBMQ4wDAYDVQQKEwVTTWV
KoZIHvcNAQkEMRYEFEOe7hq0yyoZEWUp7gA
xI5z0pabAAAAAAAAAxI5z0pabAAAAAAAAAxI5
-----END Digital Signature -----
```

전자서명 확인 II

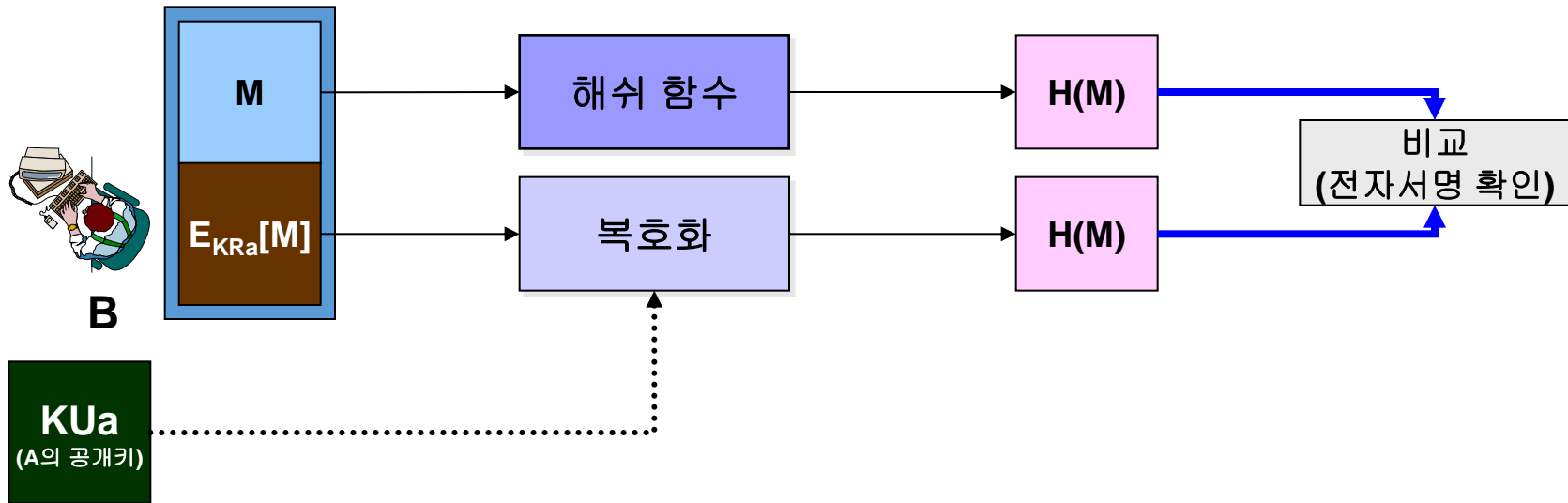

기밀성과 전자서명

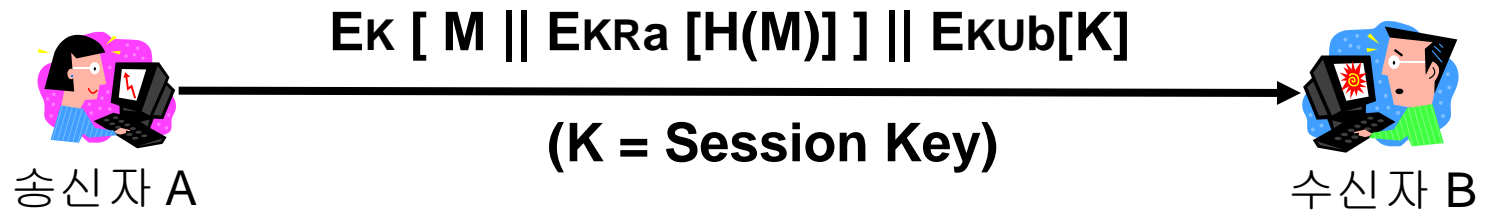

- 전자서명 생성

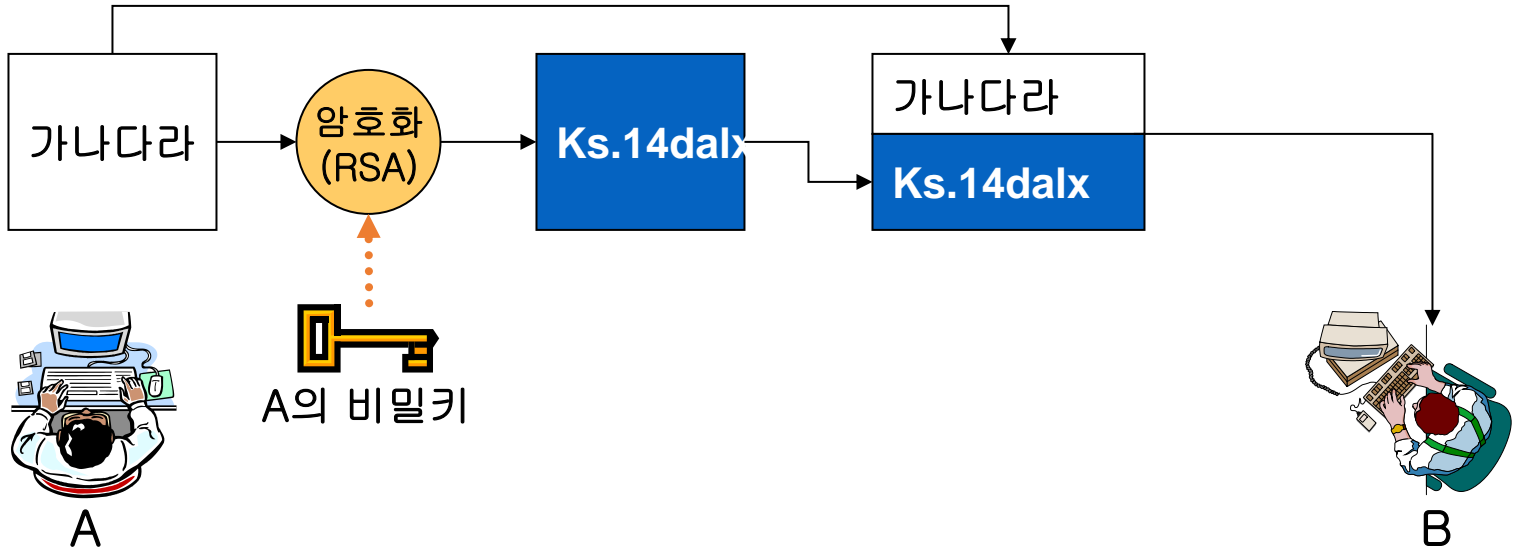

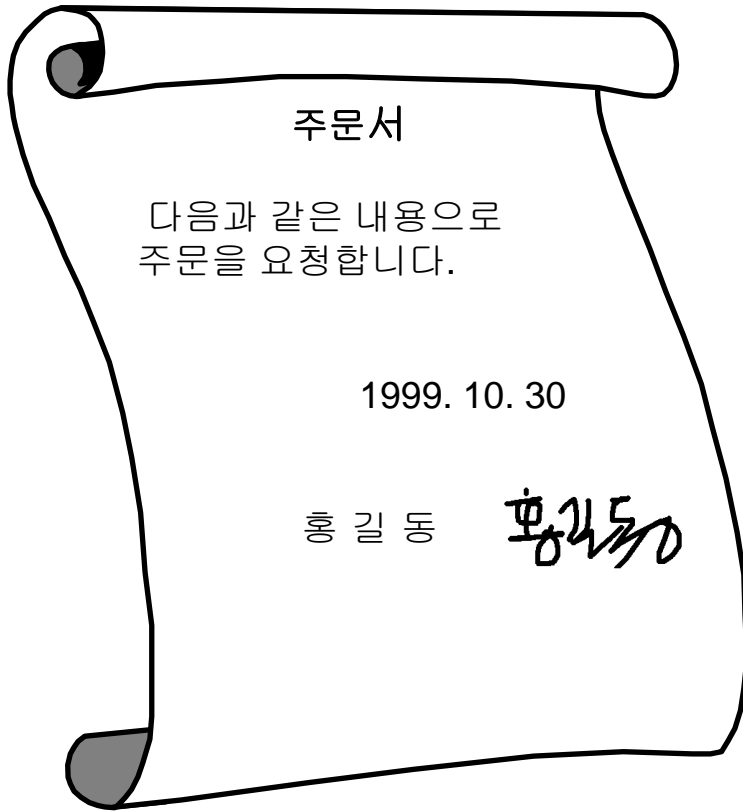

주문서

다음과 같은 내용으로 주문을 요청합니다.

1999.10.30

홍길동

-----BEGIN Digital Signature -----

Content-Type: application/x-pkcs7
-signature;

Content-Disposition: attachment;

Content-Transfer-Encoding: base64

ggM7oAMCAQICFEQ41iugpRpD1VzRmFQZQnk
TWVtZSBSb290IENBMQ4wDAYDVQQKEwVTTWV
KoZIhvcNAQkEMRYEFEoe7hq0yyoZEWUp7gA
xI5z0pabAAAAAAAAAxI5z0pabAAAAAAAAAxI5

-----END Digital Signature -----

- 전자서명 확인

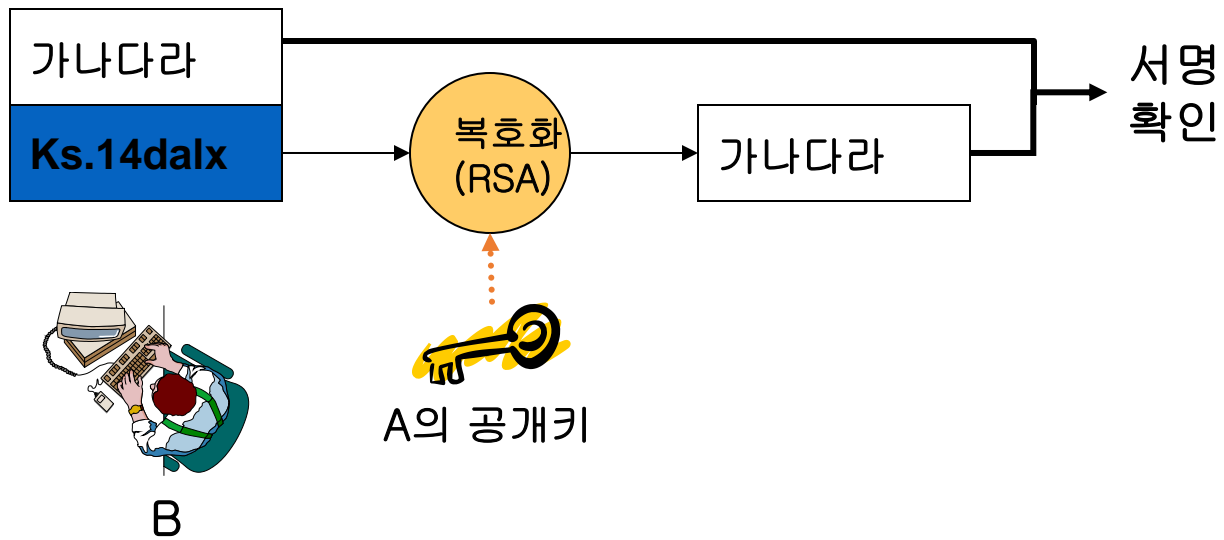

- 전자서명 확인

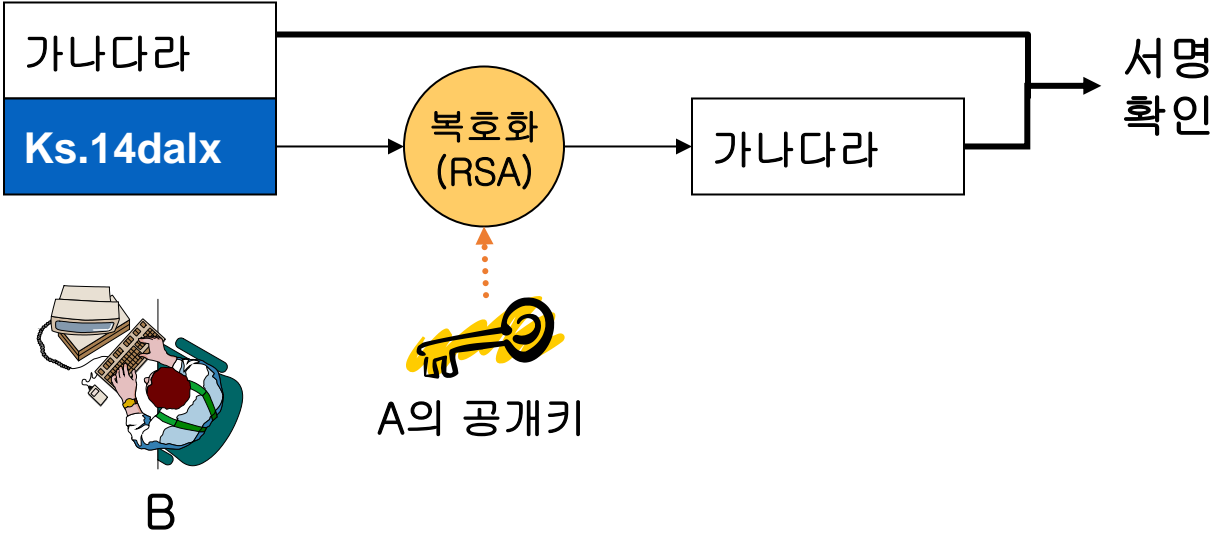

Diffie-Hellman

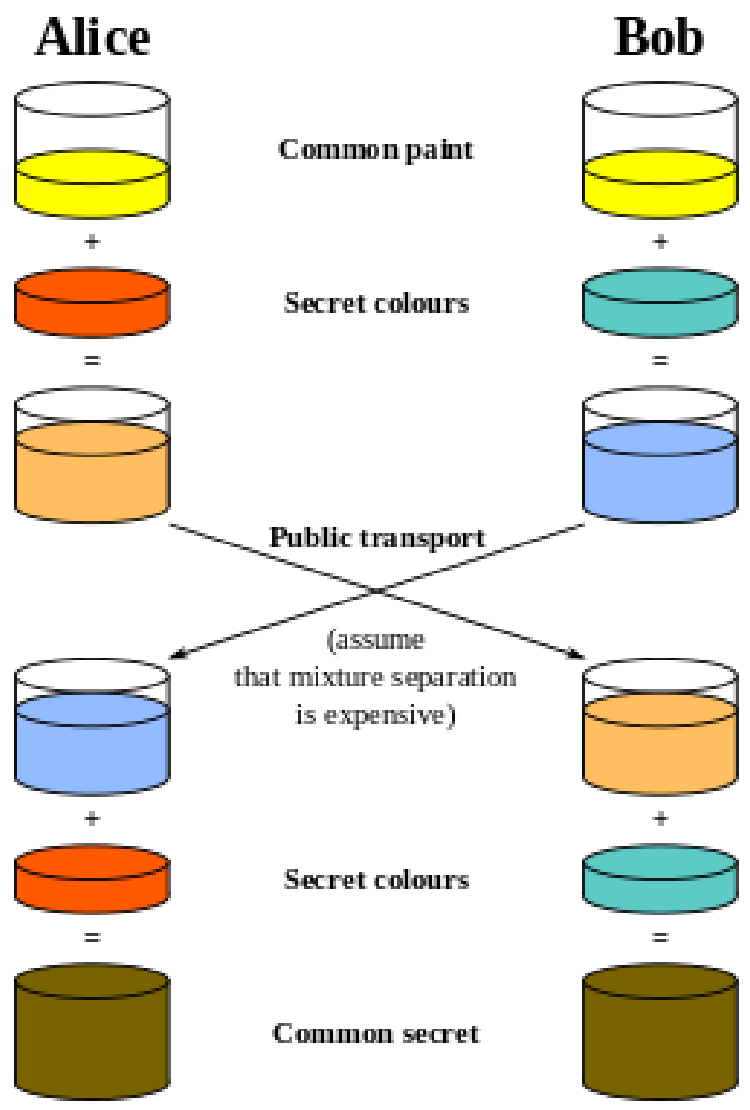

- Alice and Bob agree to use a prime number $p = 23$ and base $g = 5$ (which is a primitive root modulo 23).
- Alice chooses a secret integer $a = 6$, then sends Bob $A = g^a \bmod p$
 - $A = 5^6 \bmod 23 = 8$
- Bob chooses a secret integer $b = 15$, then sends Alice $B = g^b \bmod p$
 - $B = 5^{15} \bmod 23 = 19$
- Alice computes $s = B^a \bmod p$
 - $s = 19^6 \bmod 23 = 2$
- Bob computes $s = A^b \bmod p$
 - $s = 8^{15} \bmod 23 = 2$

RSA



Adi Sharmir

Ron Rivest

Lin Addleman



FENWAY PARK										AMERICAN LEAGUE					NATIONAL LEAGUE								
P	1	2	3	4	5	6	7	8	9	10	R	H	E	P	IN	IN	R	P	IN	R			
33	NY			APRIL						16				12	BAL	2		32	CIN		10	37	FLA
49	BOSTON													43	TOR			48	CHC		11	27	ATL
														34	DET	2		61	MON	2	1	49	MIL
														52	CLE	2		21	PHI		0	44	HOU
														36	CWS	2		32	PIT		0	41	COL
														34	TB	2		47	NYM	2	0	35	STL

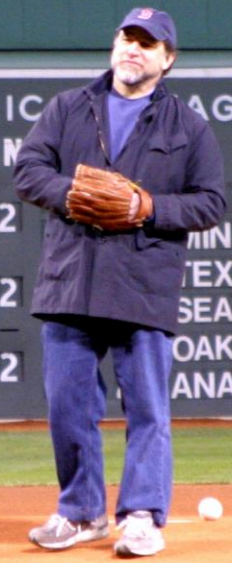

1. Select primes: $p=17$ & $q=11$
2. Compute $n = pq = 17 \times 11 = 187$
3. Compute $\phi(n) = (p-1)(q-1) = 16 \times 10 = 160$
4. Select e : $\gcd(e, 160) = 1$; choose $e=7$
5. Determine d : $de=1 \pmod{160}$ and $d < 160$ Value is $d=23$
since $23 \times 7 = 161 = 10 \times 160 + 1$
6. Publish public key $KU = \{7, 187\}$
7. Keep secret private key $KR = \{23, 17, 11\}$

- sample RSA encryption/decryption is:
- given message $M = 88$ (nb. $88 < 187$)
- encryption:
$$C = 88^7 \pmod{187} = 11$$
- decryption:
$$M = 11^{23} \pmod{187} = 88$$

인증기관(CA: Certification Authority)

- 공개키 암호방식의 문제점

 - 사용자 개인키 보관

 - ➔ IC카드 활용

 - ➔ 암호화하여 디스켓, HDD 등에 보관

 - 상대방의 공개키에 대한 진위 여부

 - ➔ 공개키에 대한 인증서(Certificate) 발행

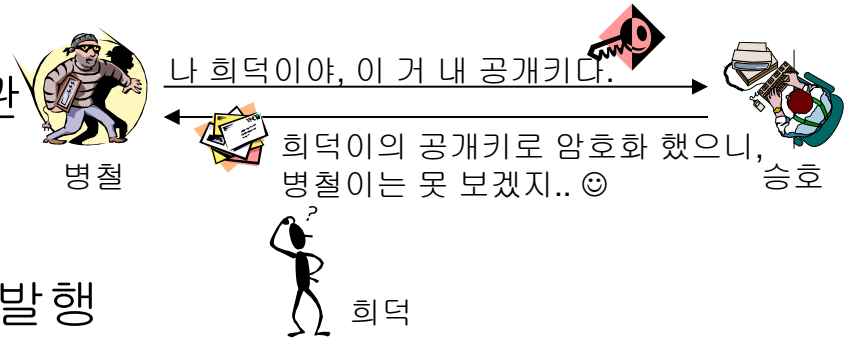

- 인증기관: CA(Certification Authority)

 - 신뢰할 수 있는 제 3기관

 - 사용자의 공개키를 확인하여 인증서 발행

인증기관의 역할

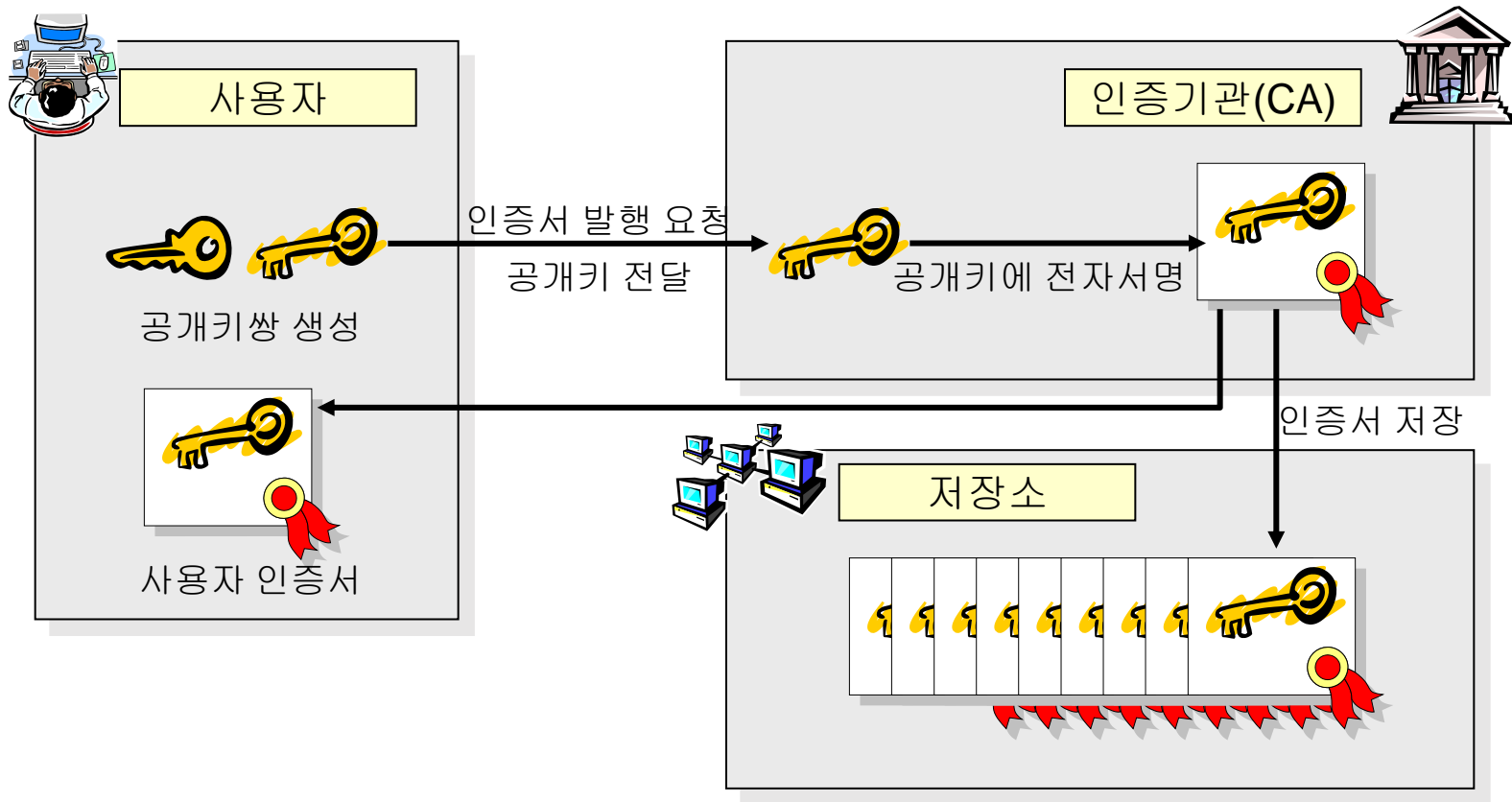

PKI: Public Key Infrastructure

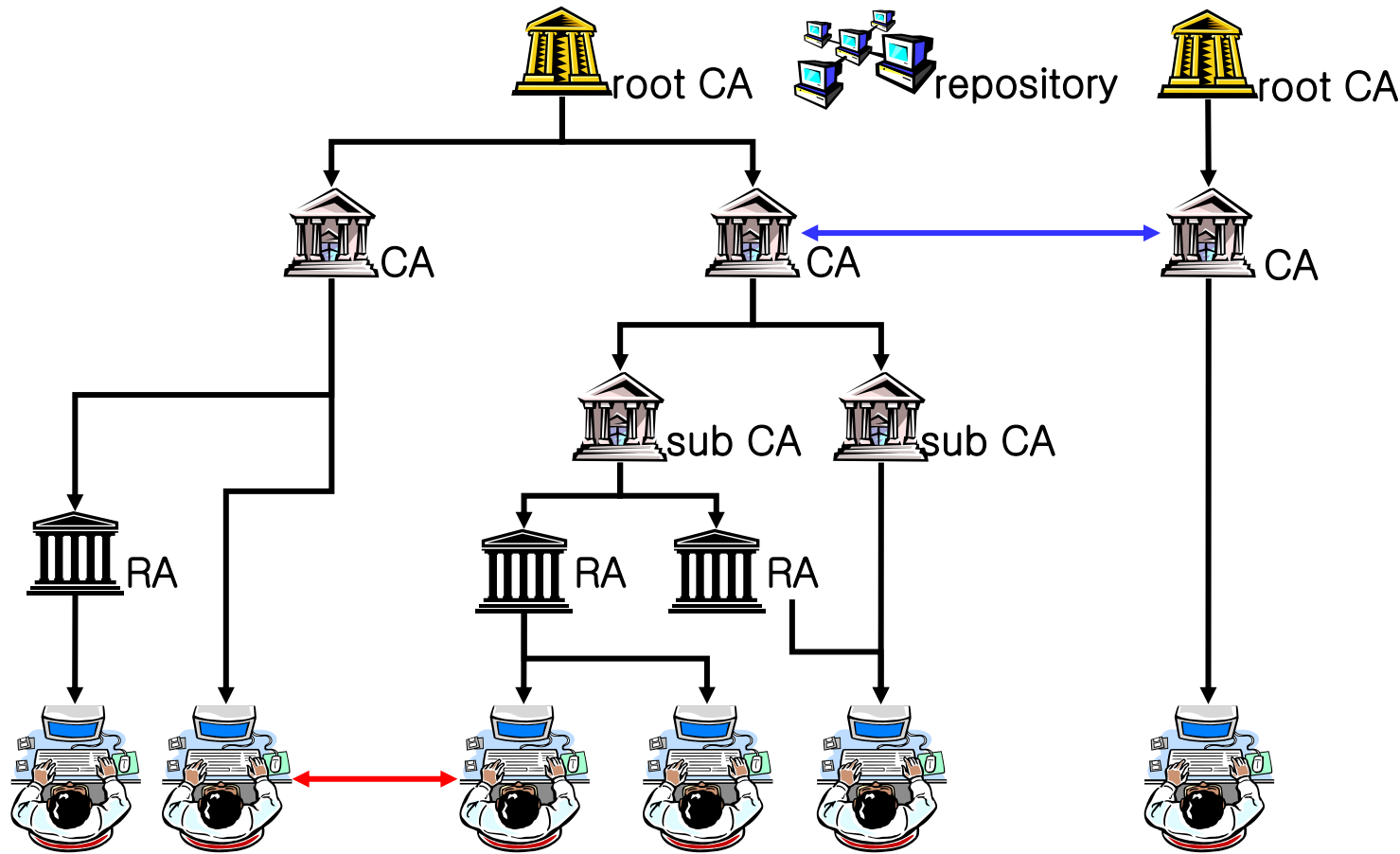

- PKI allows you to know that a given public key belongs to a given user
- PKI builds off of asymmetric encryption:
 - Each entity has two keys: public and private
 - The private key is known only to the entity
- The public key is given to the world encapsulated in a X.509 certificate



Certificates

- A X.509 certificate binds a public key to a name
- It includes a name and a public key (among other things) bundled together and signed by a trusted party (Issuer)

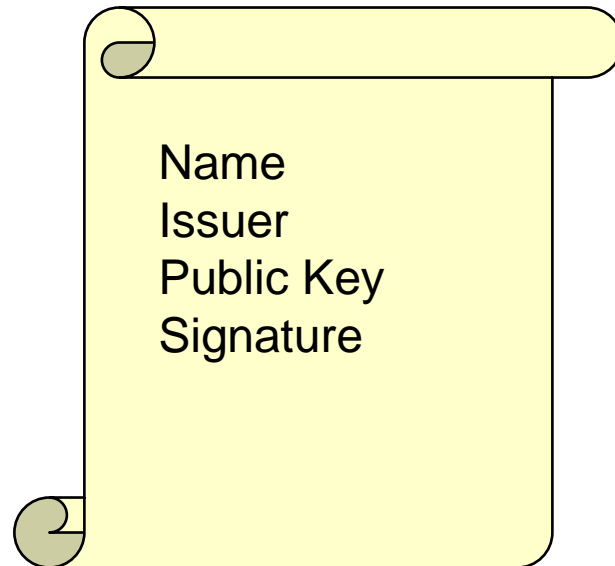

- Similar to passport or driver's license

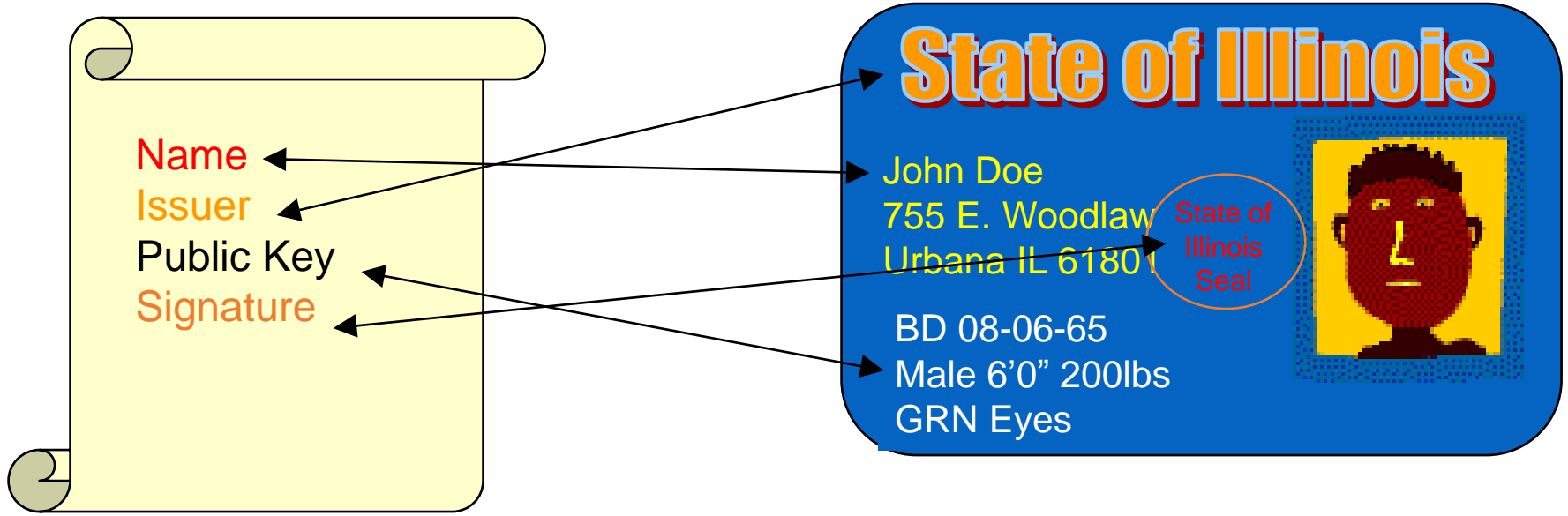

- By checking the signature, one can determine that a public key belongs to a given user.

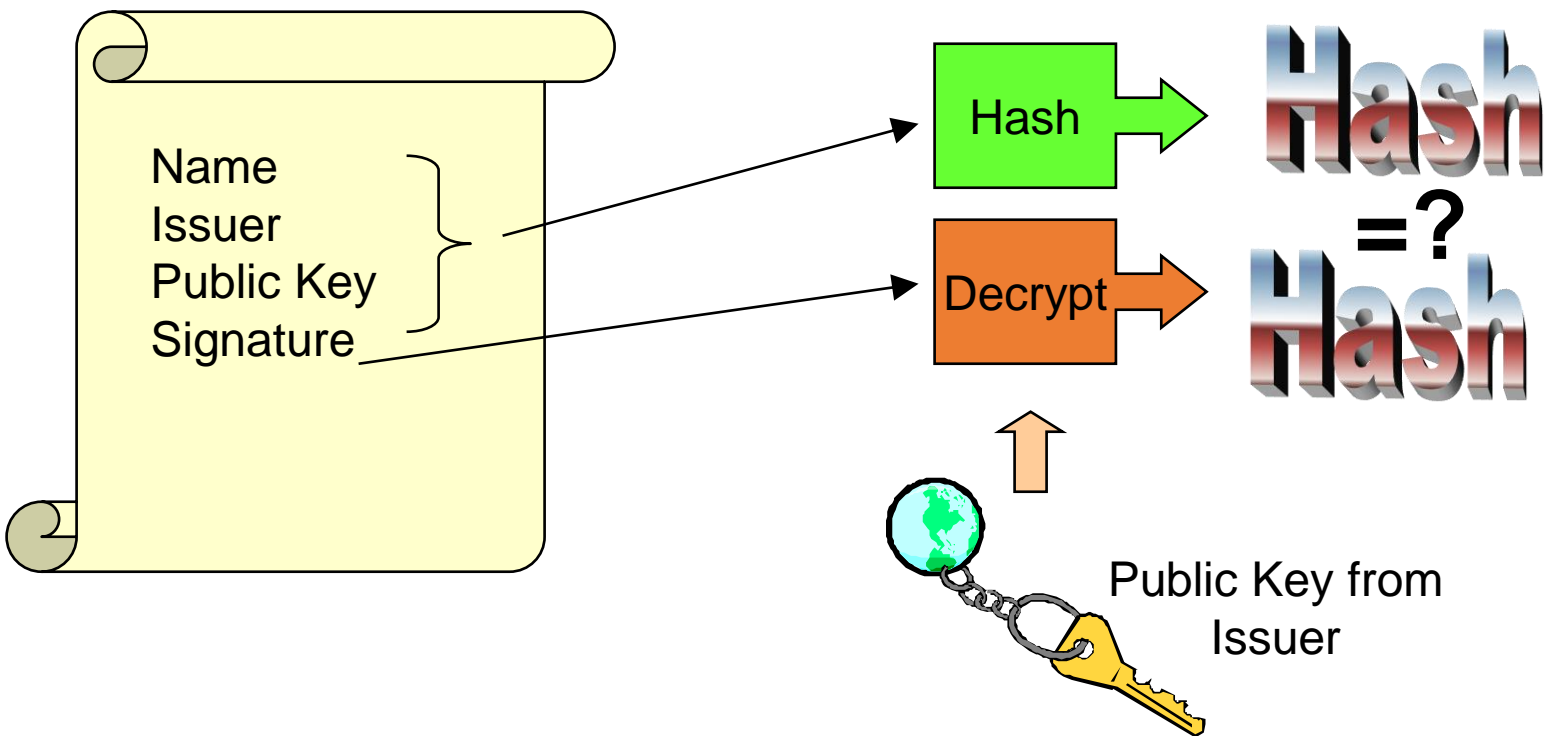

- Question: Who signs certificates?
- Answer: A small set of trusted entities known as Certificate Authorities (CAs)

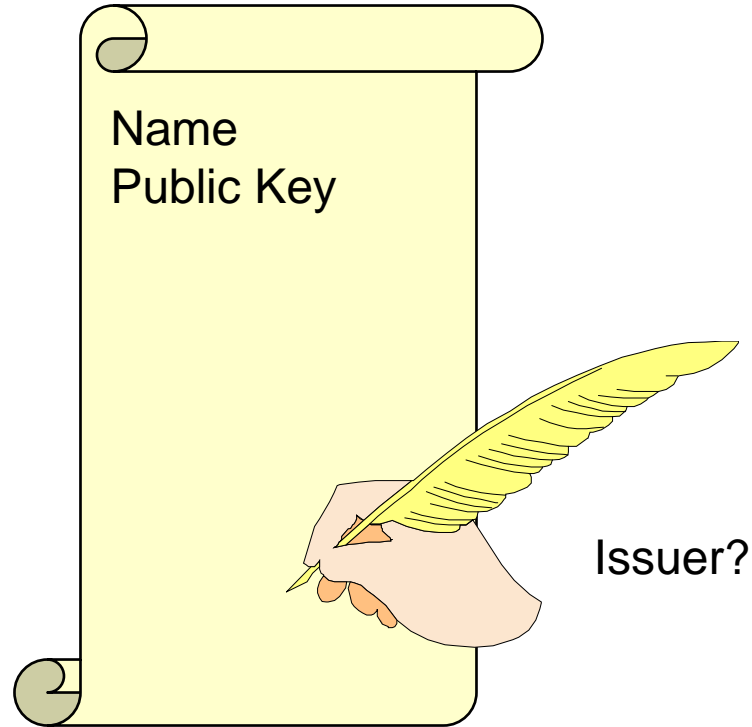

CA

- A Certificate Authority is an entity that exists only to sign user certificates
- The CA signs its own certificate which is distributed in a trusted manner

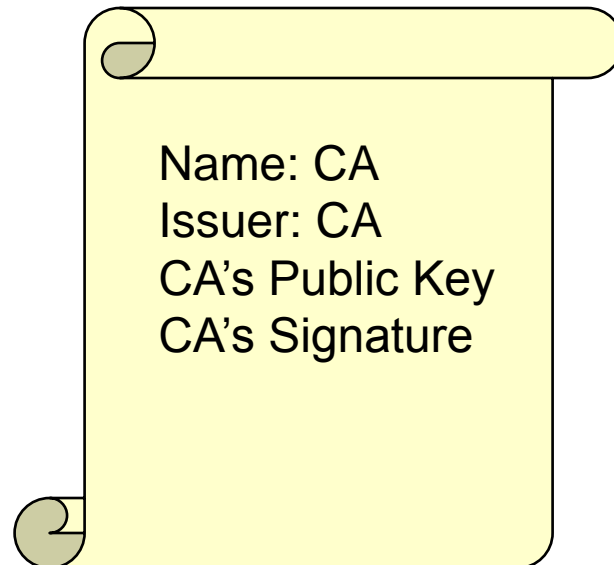

- The public key from the CA certificate can then be used to verify other certificates

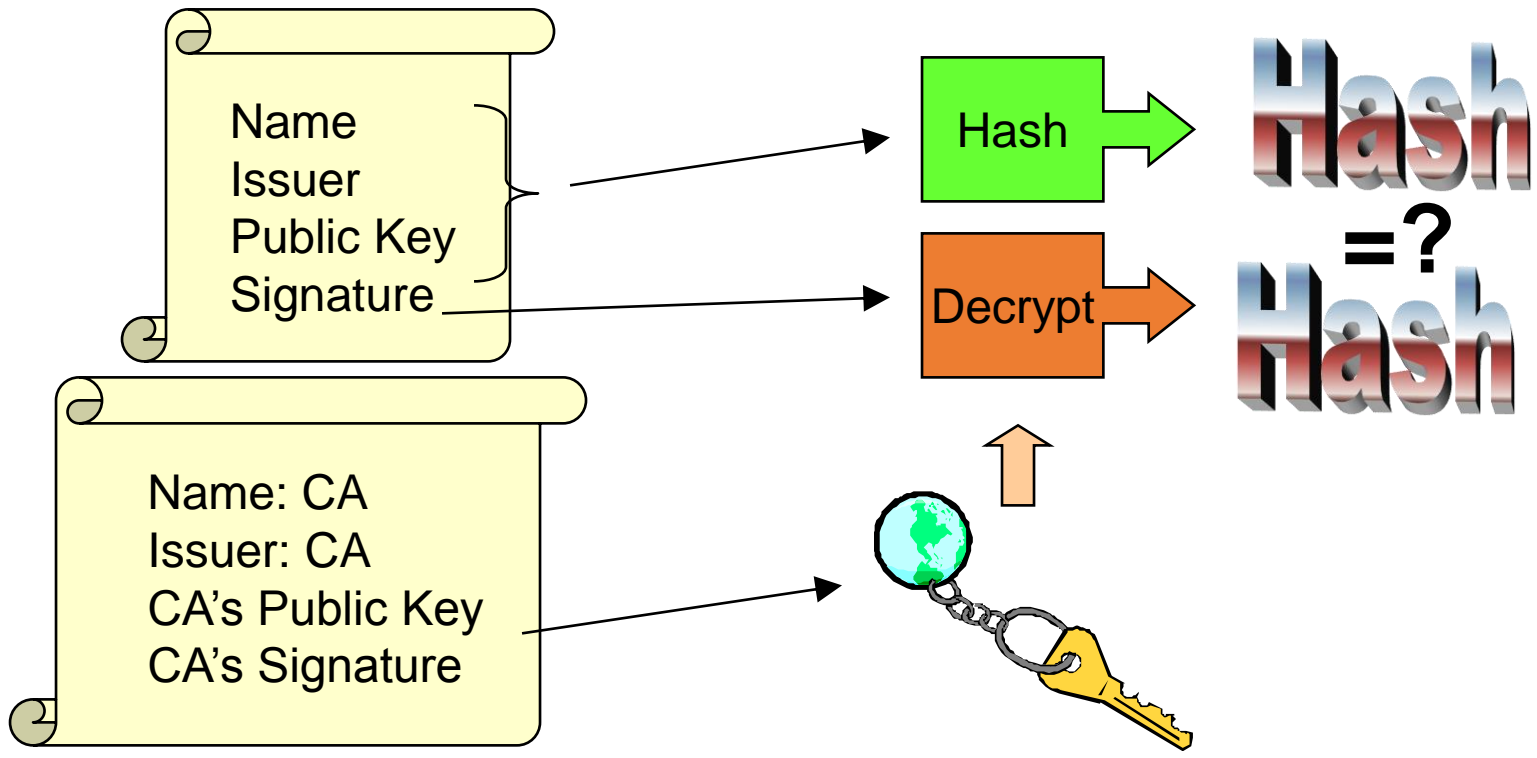

Certificate Policy(CP)

- Each CA has a Certificate Policy (CP) which states when and how a CA issues certificates.
- It states who it will issue certificates for
 - Just like the State of Illinois only issues driver's licenses' for residents of the state of Illinois
 - A CA for a grid typically only issues certificates for folks that are already approved to use resources on the grid

Certificate Policy (CP)

- A CA's CP states how it identifies the people it issues certificates to
 - Similar to having to show a birth certificate to get a driver's license
 - Some CA's are very stringent and require similar proof of identity
 - Others are lenient and only require proof via email

X.509 v3 인증서 is an IETF/[ITU-T](#) standard

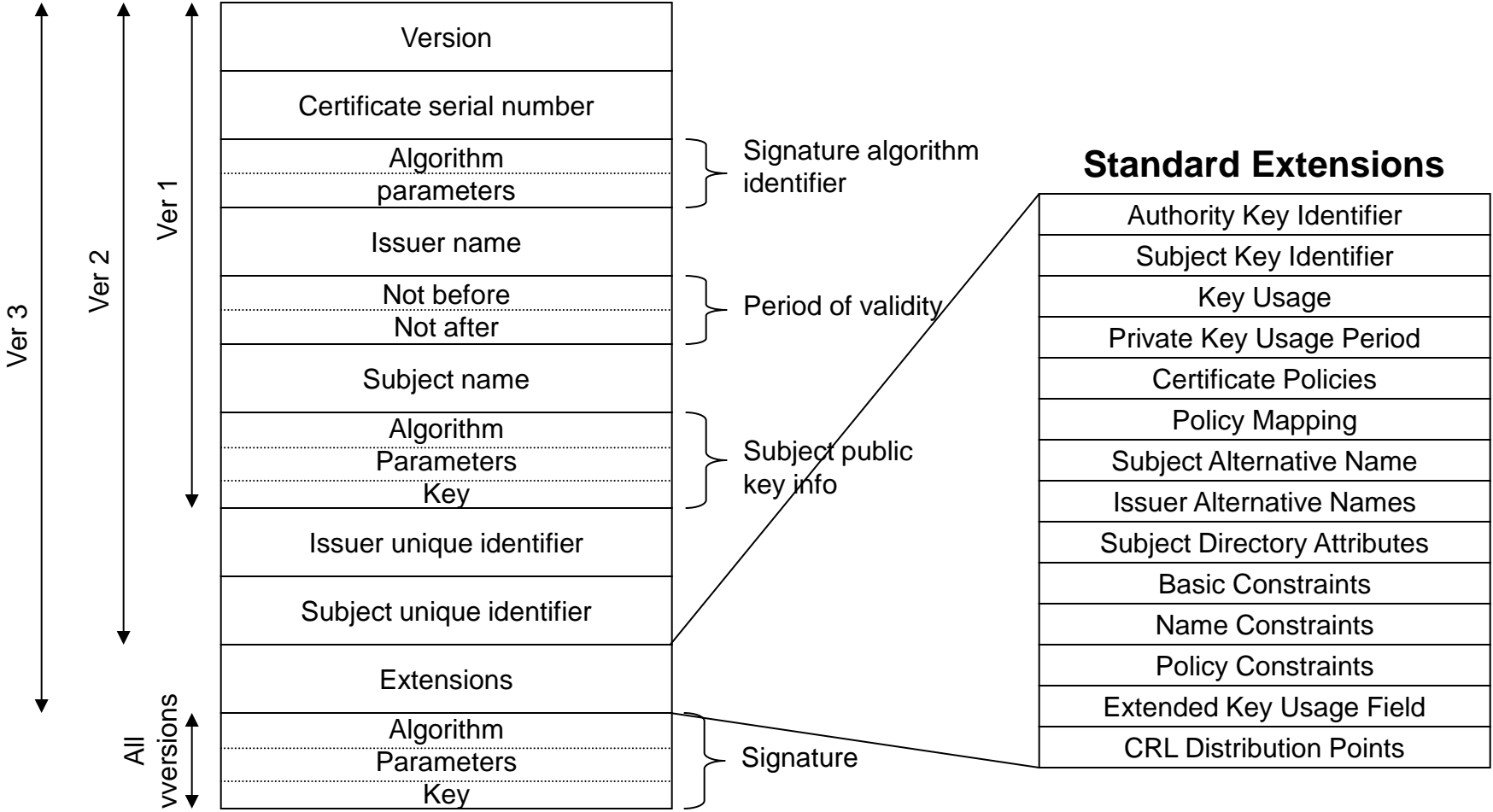

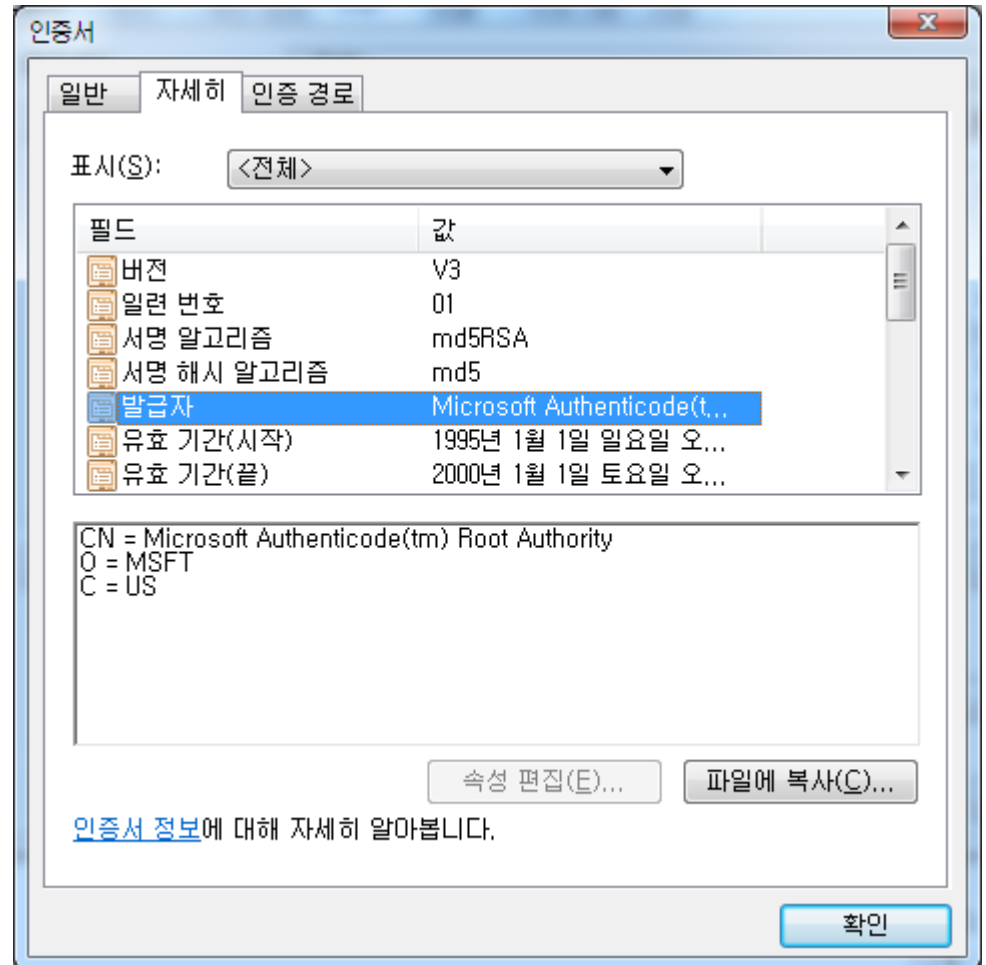
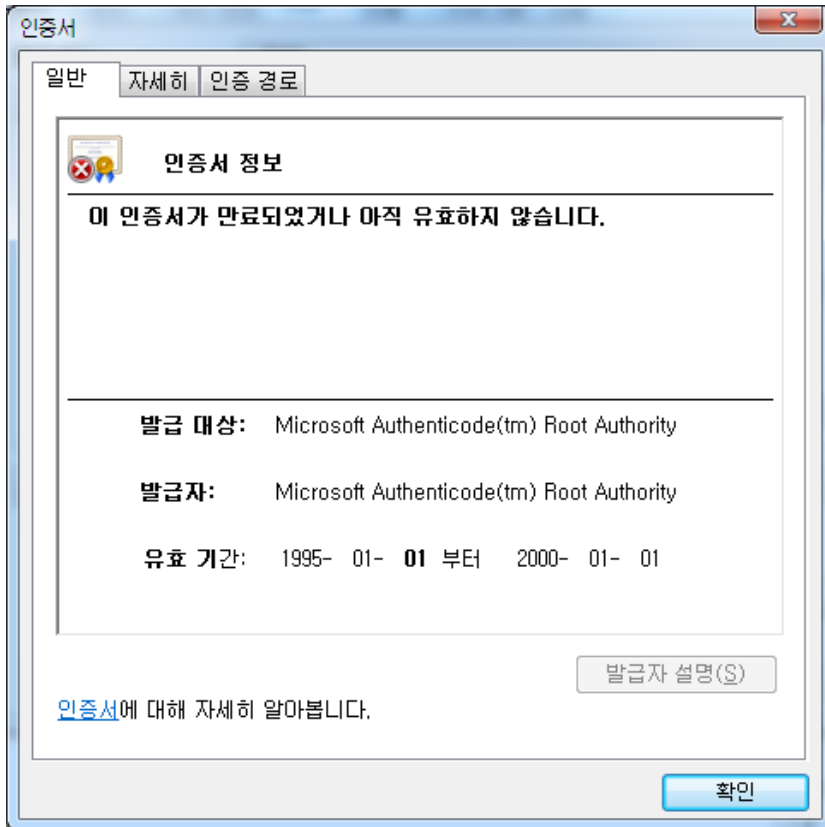

X.509 v2 CRL

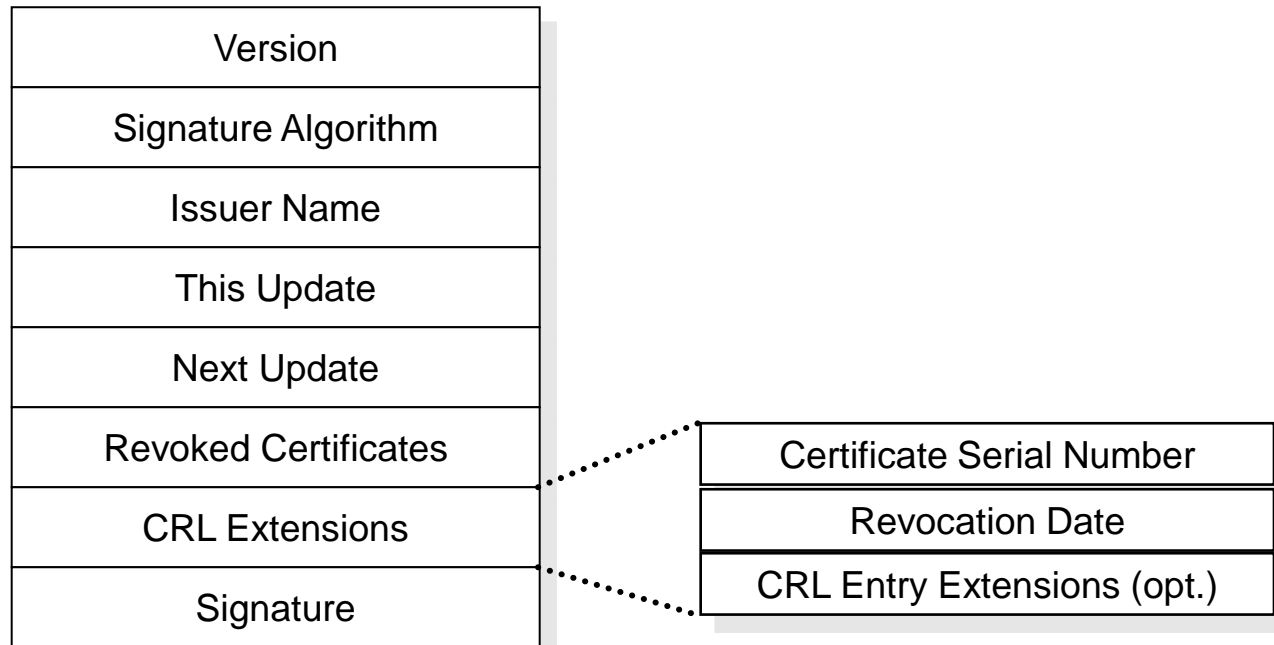

인증기관의 업무

- 사용자 신원 확인
- 인증서 발행
- 인증서 공개
- 인증서의 효력 상실
- 비밀키의 생성 및 관리
- 업무의 중단 및 관리

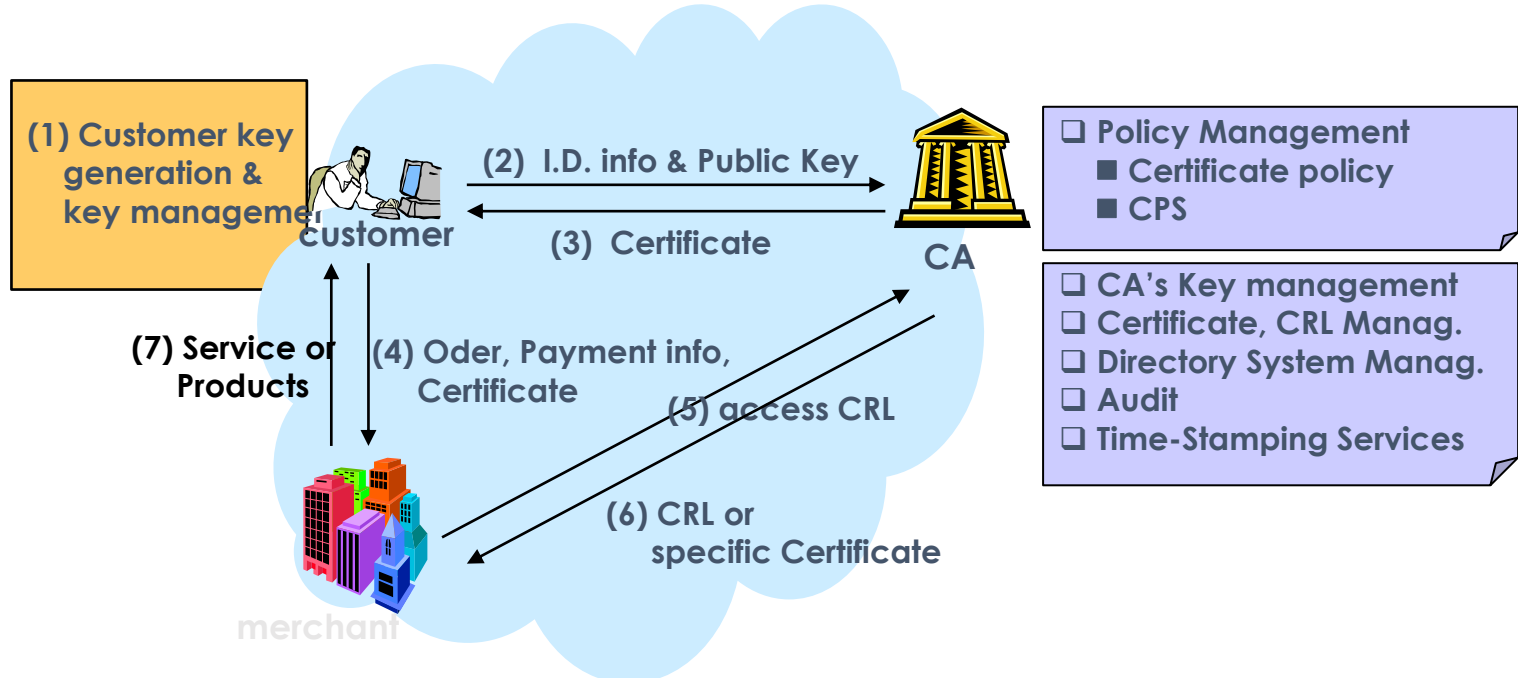

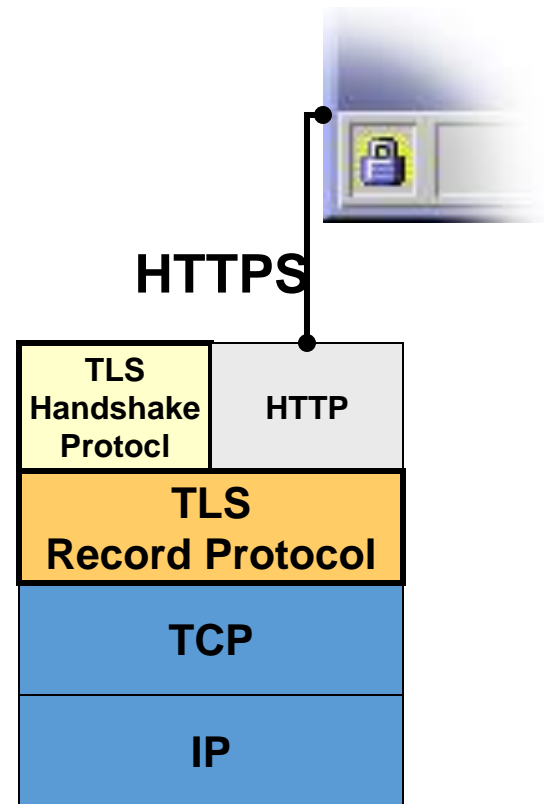
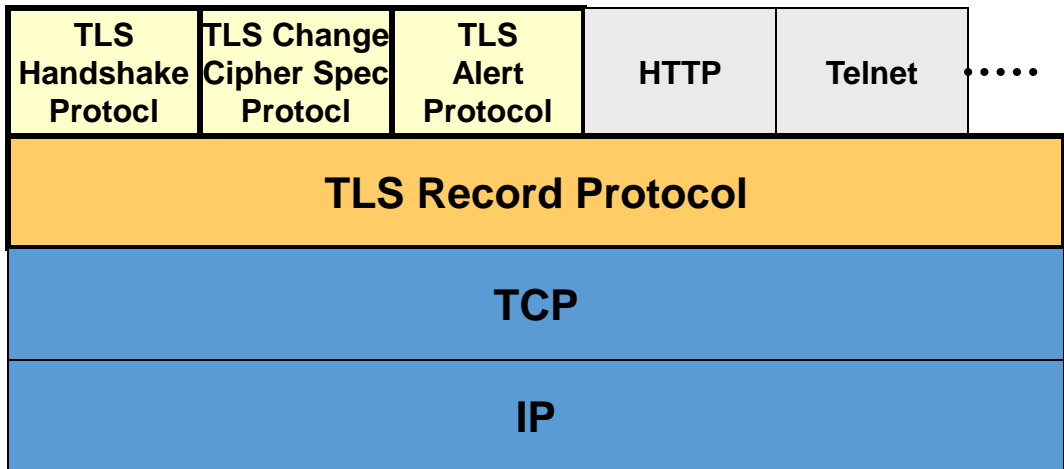

The Goals of TLS

보안 서비스 (Security)	<ul style="list-style-type: none">• 기밀성• 무결성• 사용자 인증
상호호환성 (Interoperability)	<ul style="list-style-type: none">• TLS를 이용하는 어플리케이션 간의 상호호환성 확보 (HTTP, Telnet, FTP,...)
확장성 (Extensibility)	<ul style="list-style-type: none">• 새로운 알고리즘의 추가의 용이성
효율성 (Efficiency)	<ul style="list-style-type: none">• Optional session caching scheme to reduce the # of connection

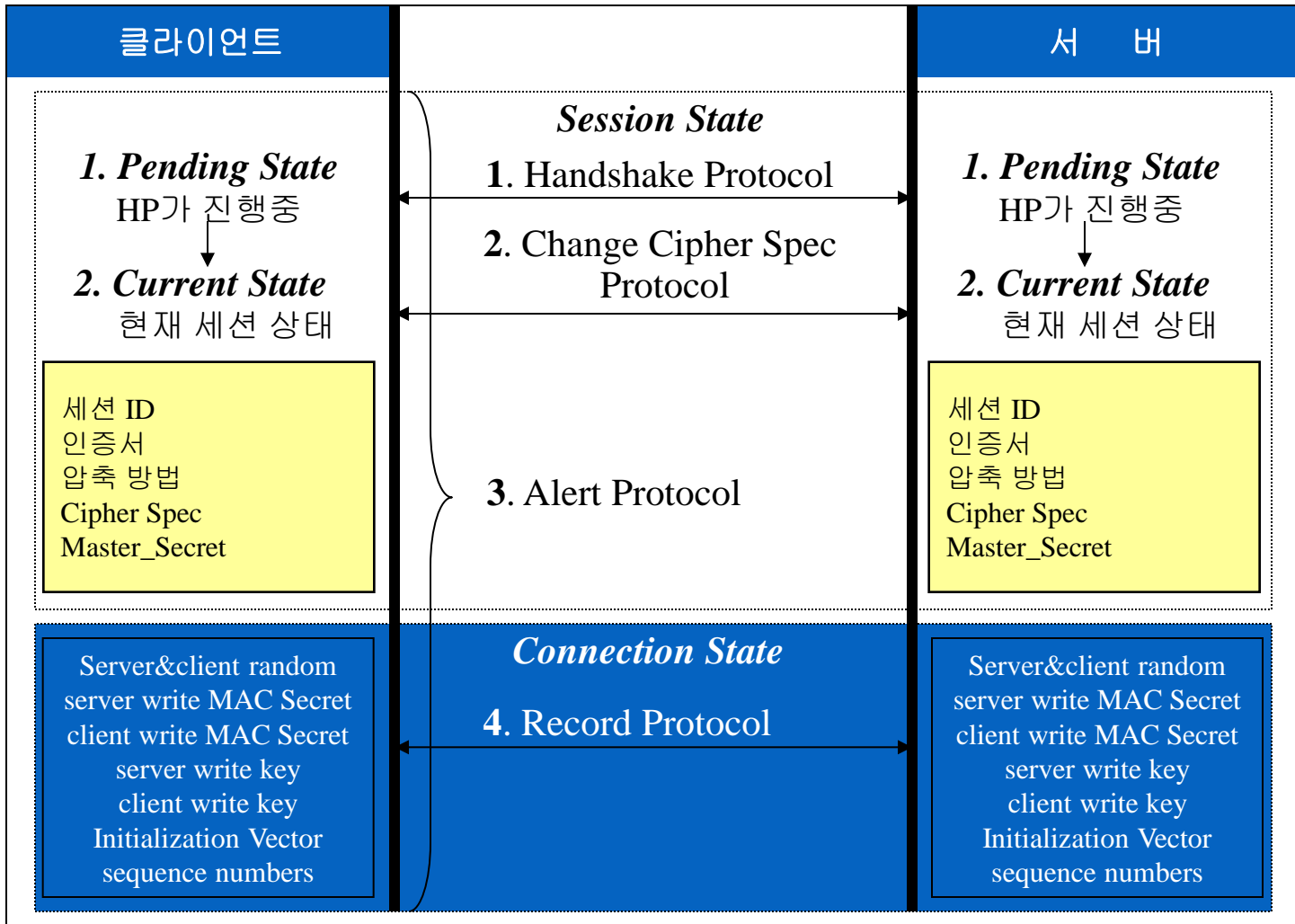

TLS 핸드셰이크 프로토콜

- 핸드셰이크의 종류
 - Full Handshake: 새로운 세션을 시작할 때
 - Abbreviated Handshake: 이전 세션을 resume하여 사용할 때
- The Handshake Protocol is responsible for negotiating a session, which consists of the following items:
 - session identifier
 - peer certificate
 - compression method
 - cipher spec
 - master secret
 - is resumable

Full Handshake

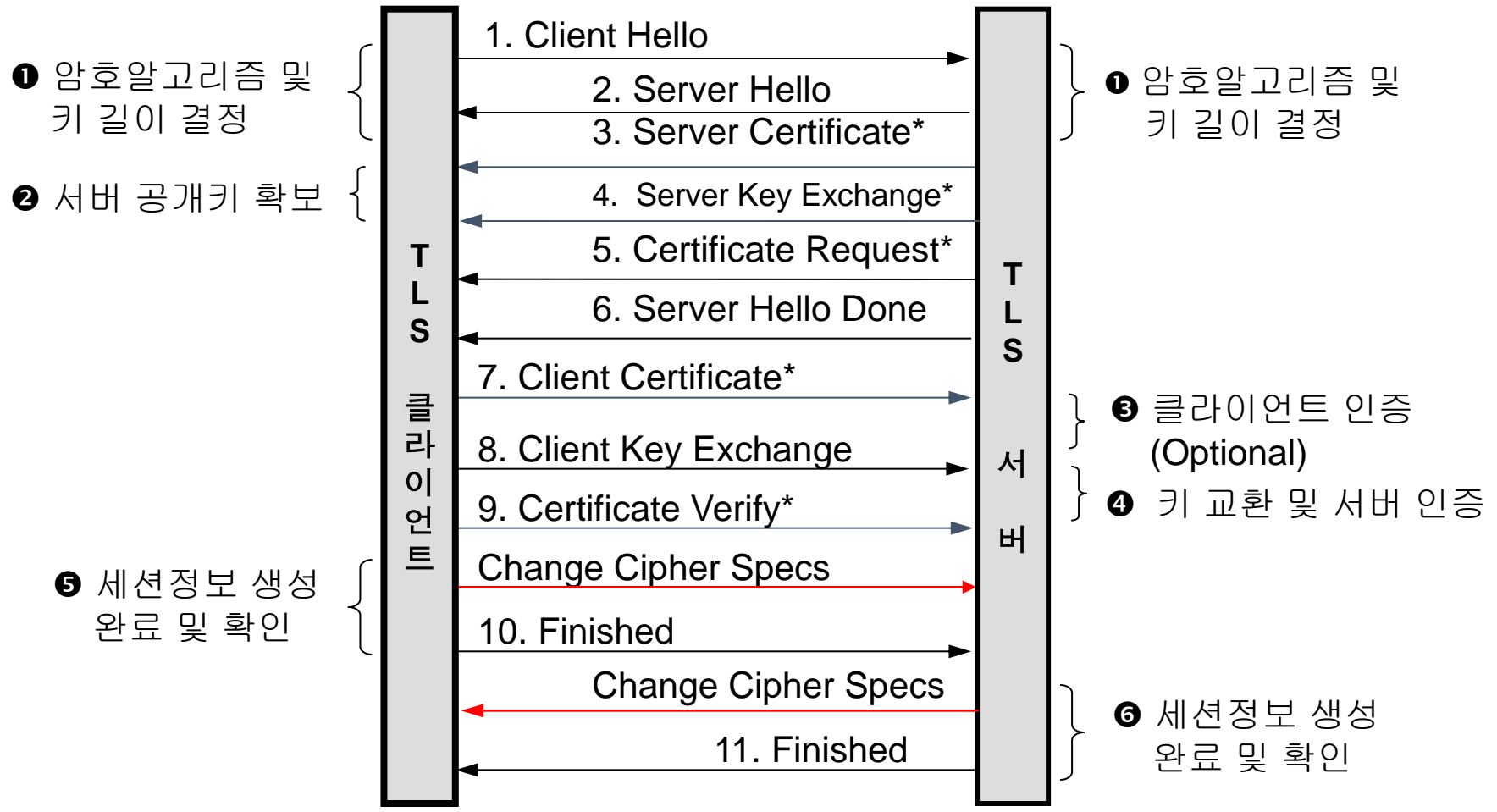

- Key Exchange Algorithms

Algorithm	Description	Key Size Limit
DHE_DSS	Ephemeral DH with DSS signature	None
DHE_DSS_EXPORT	Ephemeral DH with DSS signature	DH=512
DHE_RSA	Ephemeral DH with RSA signature	None
DHE_RSA_EXPORT	Ephemeral DH with RSA signature	DH=512, RSA=None
DH_anon	Anonymous DH, no signature	None
DH_anon_EXPORT	Anonymous DH, no signature	DH=512
DH_DSS	DH with DSS-based certificates	None
DH_DSS_EXPORT	DH with DSS-based certificates	DH=512
DH_RSA	DH with RSA-based certificates	None
DH_RSA_EXPORT	DH with RSA-based certificates	DH=512, RSA=None
NULL	No key exchange	N/A
RSA	RSA key exchange	None
RSA_EXPORT	RSA key exchange	RSA=512

Client

Server

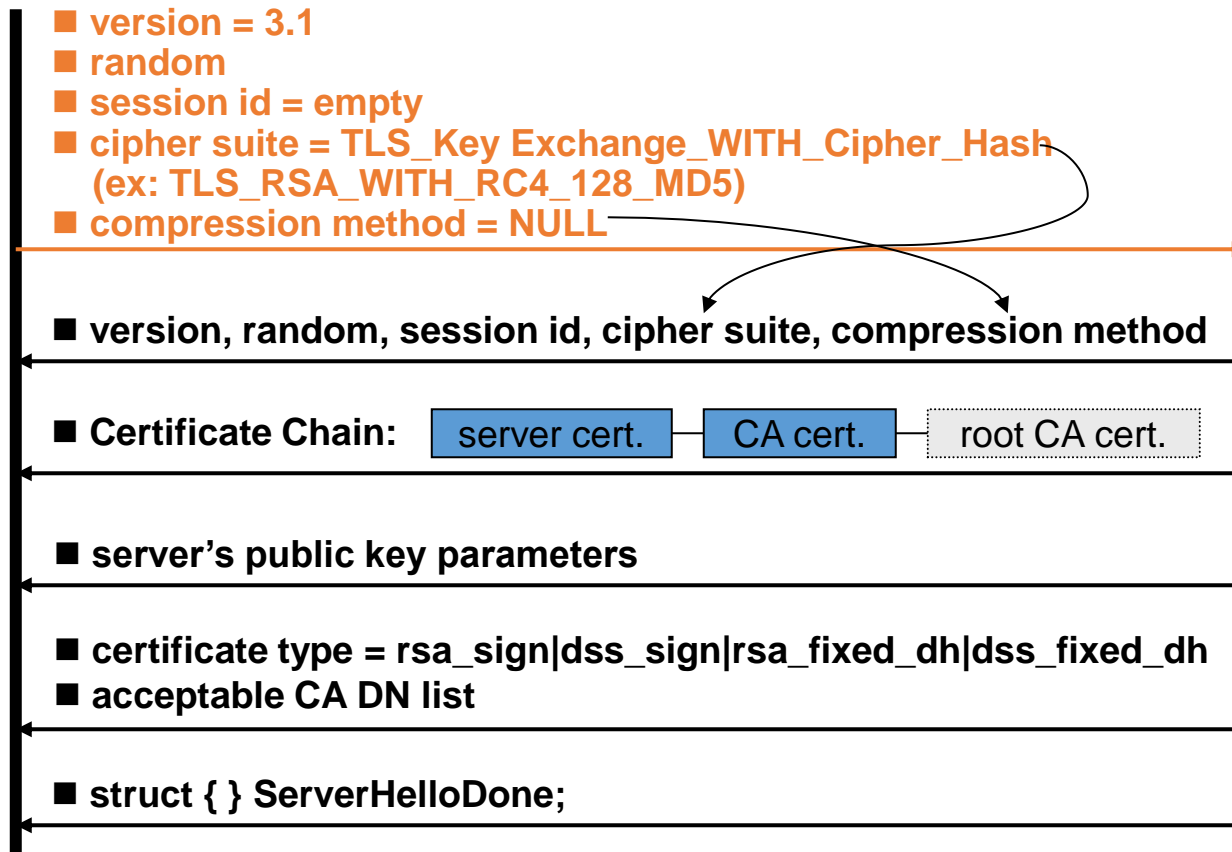

• Cipher Suites

- TLS_NULL_WITH_NULL_NULL*
- TLS_RSA_WITH_NULL_MD5*
- TLS_RSA_WITH_NULL_SHA*
- TLS_RSA_EXPORT_WITH_RC4_40_MD5*
- TLS_RSA_WITH_RC4_128_MD5
- TLS_RSA_WITH_RC4_128_SHA
- TLS_RSA_EXPORT_WITH_RC2_CBC_40_MD5*
- TLS_RSA_WITH_IDEA_CBC_SHA
- TLS_RSA_EXPORT_WITH_DES40_CBC_SHA*
- TLS_RSA_WITH_DES_CBC_SHA
- TLS_RSA_WITH_3DES_EDE_CBC_SHA
- TLS_DH_DSS_EXPORT_WITH_DES40_CBC_SHA *
- TLS_DH_DSS_WITH_DES_CBC_SHA
- TLS_DH_DSS_WITH_3DES_EDE_CBC_SHA
- TLS_DH_RSA_EXPORT_WITH_DES40_CBC_SHA*
- TLS_DH_RSA_WITH_DES_CBC_SHA
- TLS_DH_RSA_WITH_3DES_EDE_CBC_SHA
- TLS_DHE_DSS_EXPORT_WITH_DES40_CBC_SHA*
- TLS_DHE_DSS_WITH_DES_CBC_SHA
- TLS_DHE_DSS_WITH_3DES_EDE_CBC_SHA
- TLS_DHE_RSA_EXPORT_WITH_DES40_CBC_SHA*
- TLS_DHE_RSA_WITH_DES_CBC_SHA
- TLS_DHE_RSA_WITH_3DES_EDE_CBC_SHA
- TLS_DH_anon_EXPORT_WITH_RC4_40_MD5*
- TLS_DH_anon_WITH_RC4_128_MD5
- TLS_DH_anon_EXPORT_WITH_DES40_CBC_SHA
- TLS_DH_anon_WITH_DES_CBC_SHA
- TLS_DH_anon_WITH_3DES_EDE_CBC_SHA

Client

Server

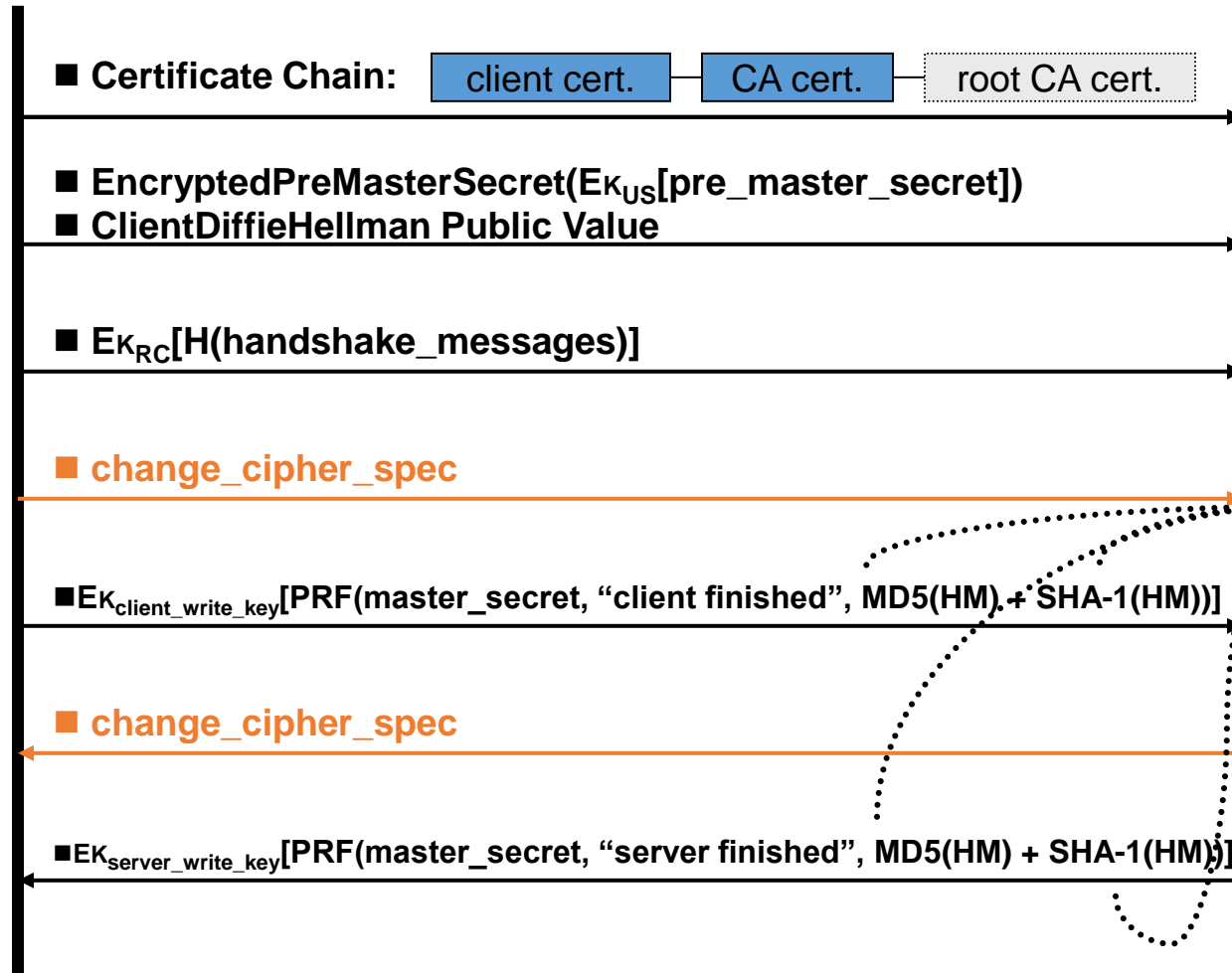

이전에 교환된 모든 핸드셰이크 메시지 (Change Cipher Spec 제외)

레코드 프로토콜

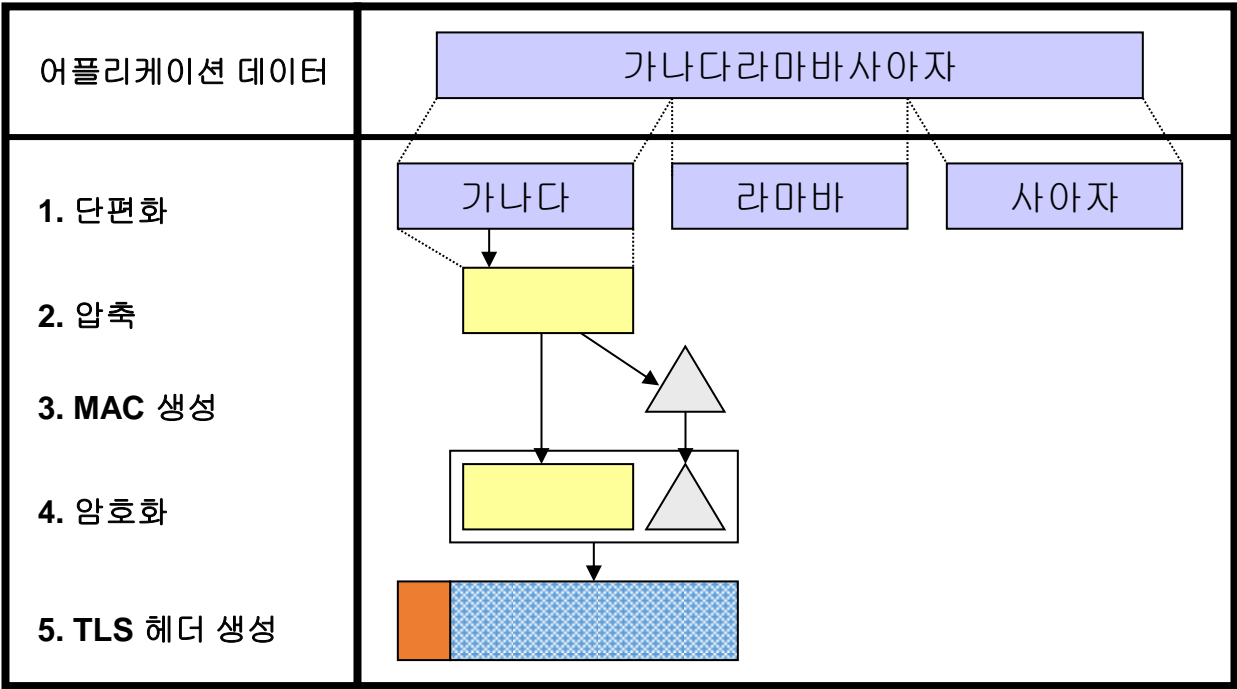

- 단편화
 - 2^{14} 바이트로 단편화
- 압축
 - SSL 3.0/TLS 1.0에서는 지원하지 않음
- MAC 생성

```
HMAC_hash(MAC_write_secret, seq_num +
           TLSCompressed.type +
           TLSCompressed.version +
           TLSCompressed.length +
           TLSCompressed.fragment)
```

- 레코드 페이로드 생성

Content Type(1)	Major Version(1)	Minor Version(1)
Compress Length(2 bytes)		
암호화 데이터		

Cryptographic Computation

- Master Secret(48byte) 계산

```
master_secret = PRF(pre_master_secret, "master secret",  
                    ClientHello.random + ServerHello.random)
```

```
PRF(secret, label, seed) = P_MD5(S1, label + seed) XOR  
                          P_SHA-1(S2, label + seed)
```

```
P_hash(Secret, seed) = HMAC_hash(secret, A(1) + seed) +  
                      HMAC_hash(secret, A(2) + seed) +  
                      HMAC_hash(secret, A(3) + seed) + .....
```

```
A(0) = seed
```

```
A(i) = HMAC_hash(secret, A(i-1))
```

- Key Block 생성: 필요한 길이만큼 생성

```
key_block = PRF(SecurityParameters.master_secret, "key expansion",  
                SecurityParameters.server_random +  
                SecurityParameters.client_random);
```

- Key Block를 다음과 같이 분리해서 키를 생성
 - ex) IDEA_CBC_SHA

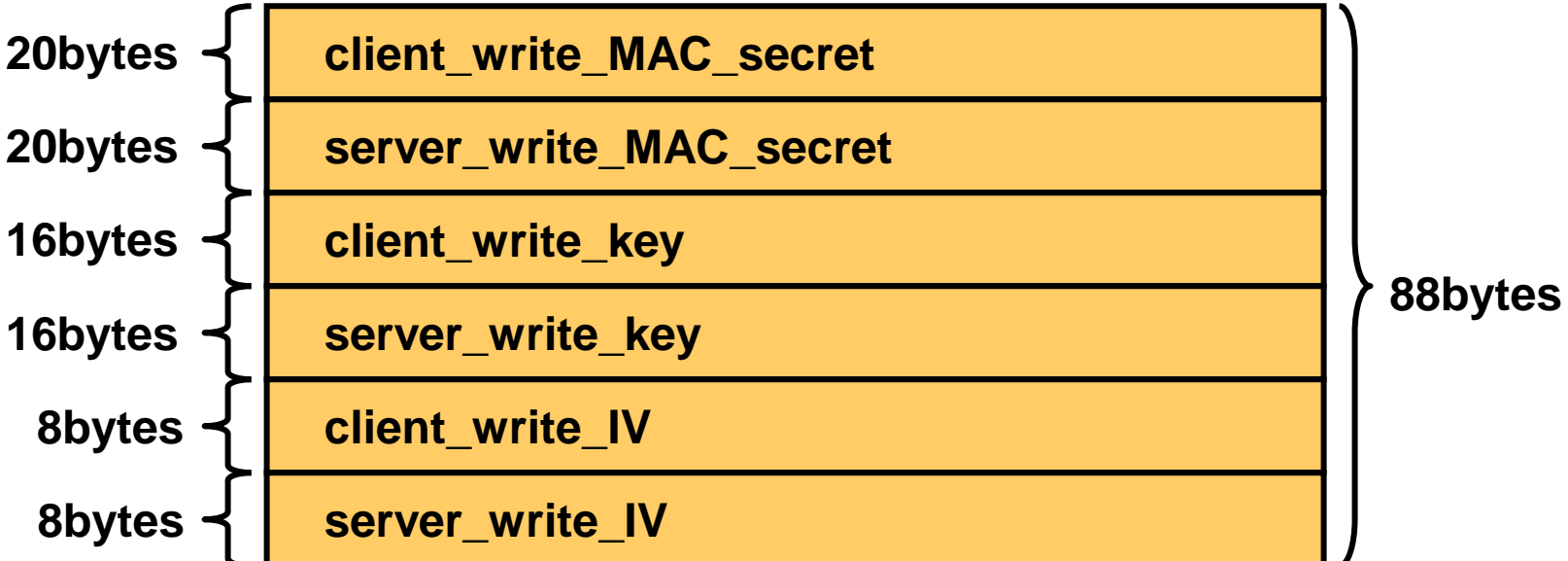

5. 결론

- The Grid Security Infrastructure (GSI) is a set of tools, libraries and protocols used in Globus to allow users and applications to securely access resources.
- Based on a public key infrastructure, with certificate authorities and X509 certificates
- Uses SSL for authentication and message protection
- Adds features needed for Single-Sign on
 - Proxy Credentials
 - Delegation
- In the GSI system each user has a set of credentials they use to prove their identity on the grid
 - Consists of a X509 certificate and private key
- Long-term private key is kept encrypted with a pass phrase
 - Good for security, inconvenient for repeated usage
- Single-sign on is important feature for Grid Applications
 - Enables easy coordination of multiple resources
 - User authenticates themselves once, then can perform multiple actions without re-authentication
 - Can allow processes to act on their behalf
- To support single sign-on GSI adds the following functionality to SSL:
 - Proxy credentials
 - Credential delegation

GSI in Action

“Create Processes at A and B that Communicate & Access Files at C”

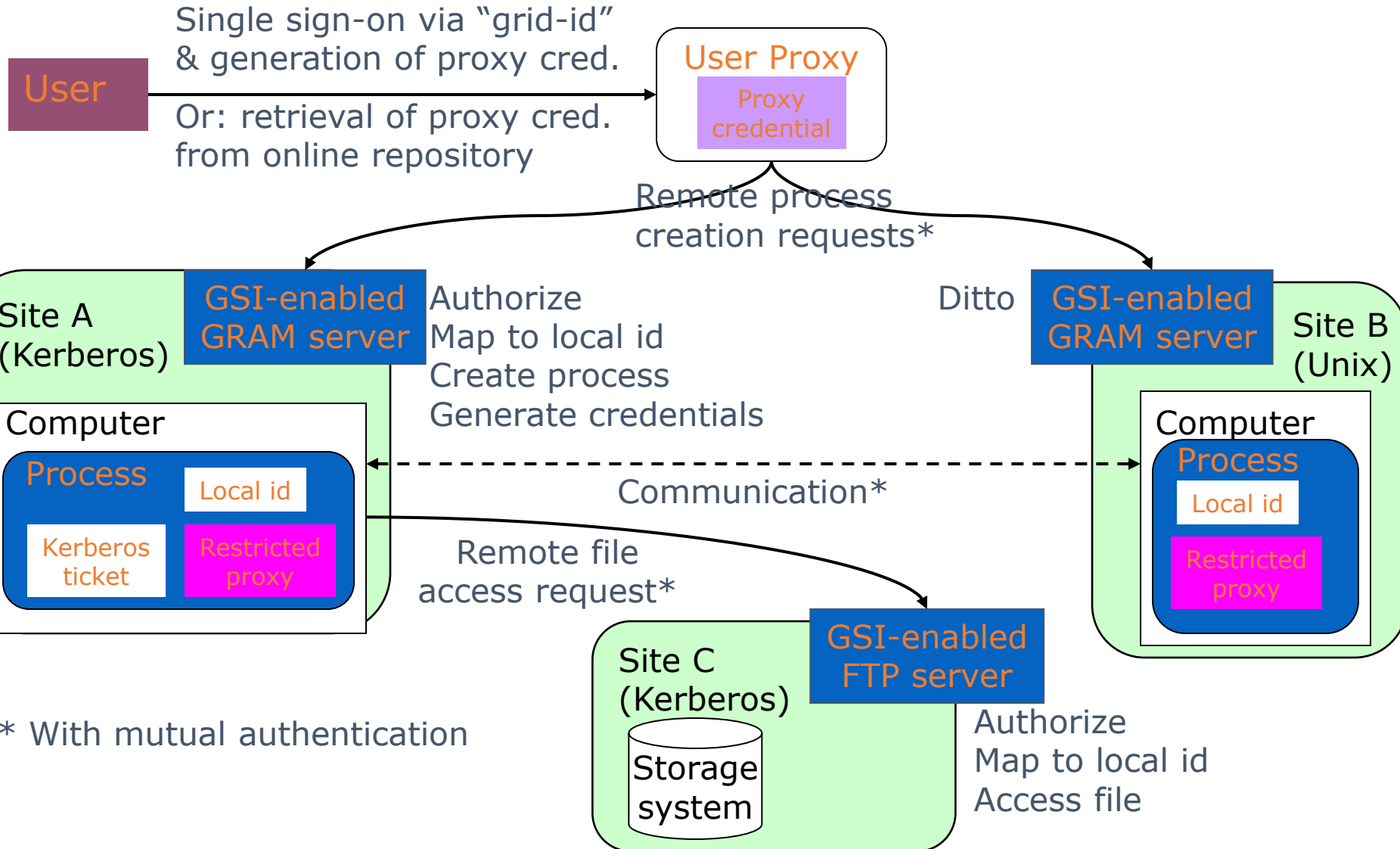

Vinaka
 감사합니다
 Dank Je
 Blagodaram
 Ngiyahonga
 Dziękuje
 Juspaxar
 நன்றி
 Ua Tsaug Rau Koj
 Dėkuji
 Suksama
 Rahmat
 Misaotra
 Matur Nuwun
 谢
 谢
 xвала
 Danke
 Merci
 Salamat
 Go Raibh Maith Agat
 ໂອໂອໂອໂອໂອໂອ
 Njais Tuke
 Maake
 Kam Sah Hammida
 Mauruuru
 Mauruuru
 Biyan
 Chokrane
 Arigato
 Gracias
 Grazas
 Niringrazzjak
 Hvala
 Welalin
 Di Ou Mesi
 Kia Ora
 Kop Khun Khap
 Paldies
 Obrigado
 Djiere Dieuf
 Eskerrik Asko
 Shukria
 Dhanyavadagalu
 Manana Dankon
 Araksh
 Maana
 Dankon
 Dloich i Chi
 Terima Kasih
 Taiku
 Tack
 Grazie
 Mochchakkeram
 Tingki
 Gratias Tibi
 Matondo
 Taiku
 Tack
 Grazie
 Mochchakkeram
 Tingki
 Gratias Tibi
 Obrigado
 Djiere Dieuf
 Eskerrik Asko

Thank You