

Girder Re-alignment using Survey and Beam Data

M. Apollonio – Diamond Light Source Ltd.

Low Emittance Design Workshop, ALBA (Barcelona), April 24th 2015

thanks to:

M. Boge, R. Bartolini, R. Dowd, X. Huang, L. Nadolski, J. Safranek, ...

- Motivations

- Beam Based Alignment

- Quadrupole centring*
- Sextupole centring*
- ORM based techniques (LOCO)*

- Girder Alignment

- Survey Assisted (SAGA)*
- Beam Assisted (BAGA)*

- Conclusions

Alignment techniques

Why aligning the machine?

- a perfectly aligned machine ensures **nominal performance**
- first requirement to get nominal photon beam properties
- orbit distortions minimized via **orbit corrections**
 - CMs correct orbit but introduce **dispersion in both planes**
 - Orbit is zero at BPMs / can be **$\neq 0$ anywhere else**
- **misalignments after installation** or growing in time require corrections, otherwise:
 - orbit **distortions**
 - **dispersion** (emittance increase)
 - **tune shifts** / beta-beating
 - linear **coupling**
 - non linear **resonances**
 - **dynamic & momentum aperture** issues
 - **mis-alignment** with photon beamlines

Further alignment can be necessary **after** installation

Usually rely on **Beam Based** Techniques:

- **BPM / quadrupole centring** (BBA) [or sextupole centring]
 - Diamond, SLS, ASLS, SPEARIII ...
- **BPM rolls**
 - Diamond, SLS, ASLS, ...
- **Individual magnet** alignment
 - ASLS, ...
- **Girder Based** Alignment
 - Diamond, SLS, ASLS, SOLEIL, ...

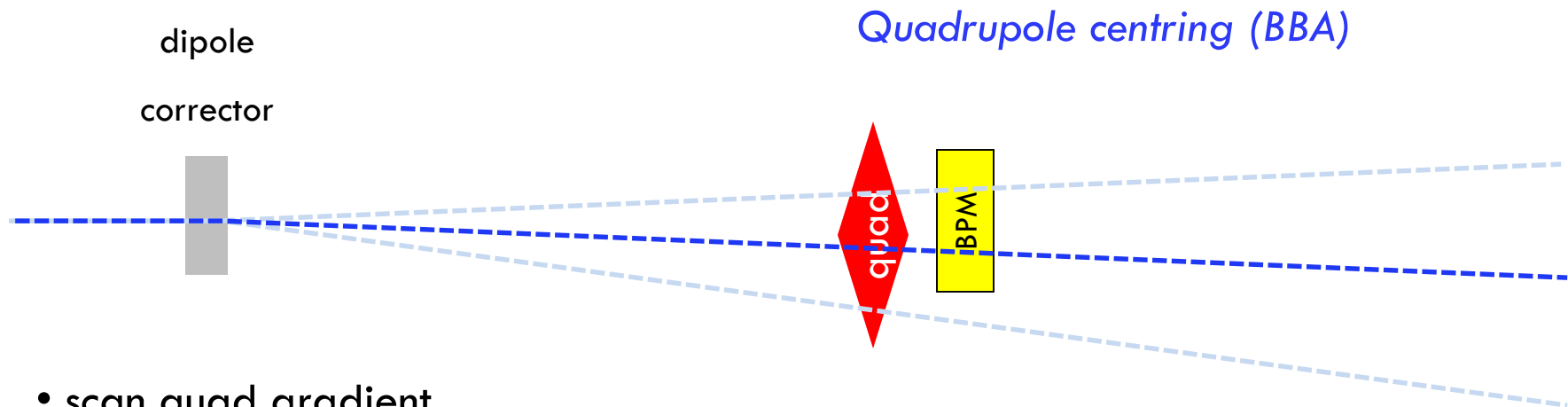

- scan quad gradient
- if orbit moves, beam is not at centre of quad
- change upstream corrector(s) to change position of the beam in quad
- the zero of the adjacent BPM is re-defined when orbit does not move anymore
- orbit correction will put the beam at the (magnetic) centre of the quad
- crucial at commissioning (+LOCO, +Orbit Corrections)
- routinely repeated over the ring @ every run (~ each month)
- aimed at few BPMs if recently “touched”

BBA offsets @ SPEAR III : < 700um
 Reproducibility: 25 um after 38d

Quadrupole centring (BBA)

quadcenter.m G. Portman et al.
 [MATLAB middlelayer]

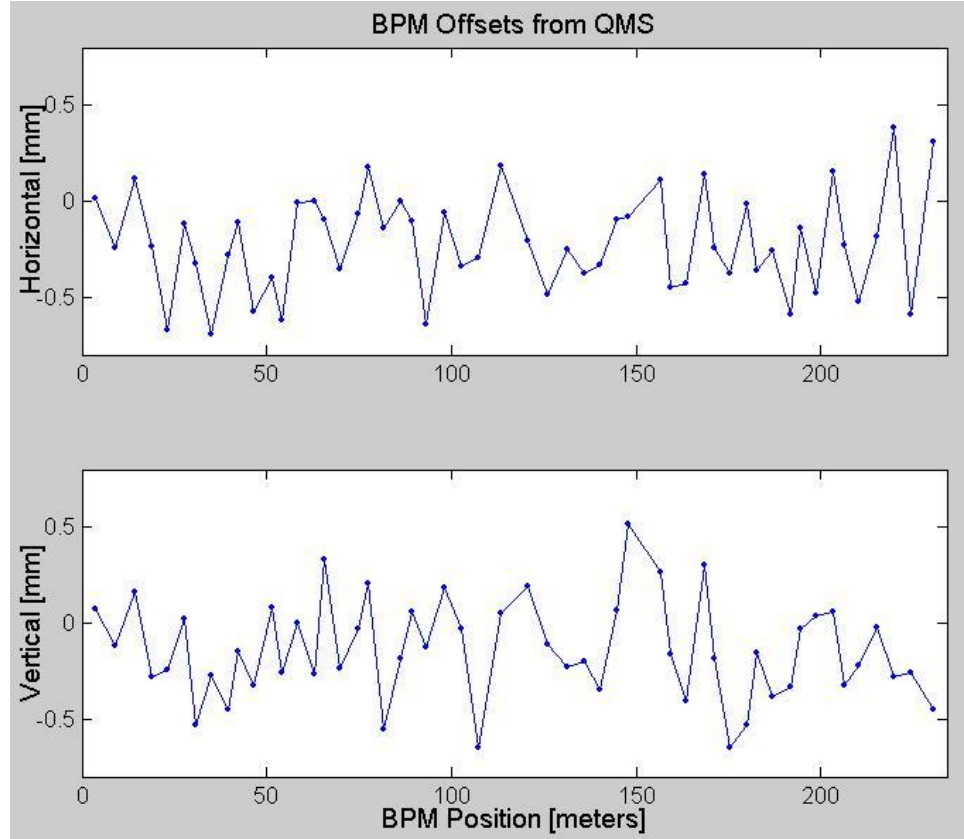
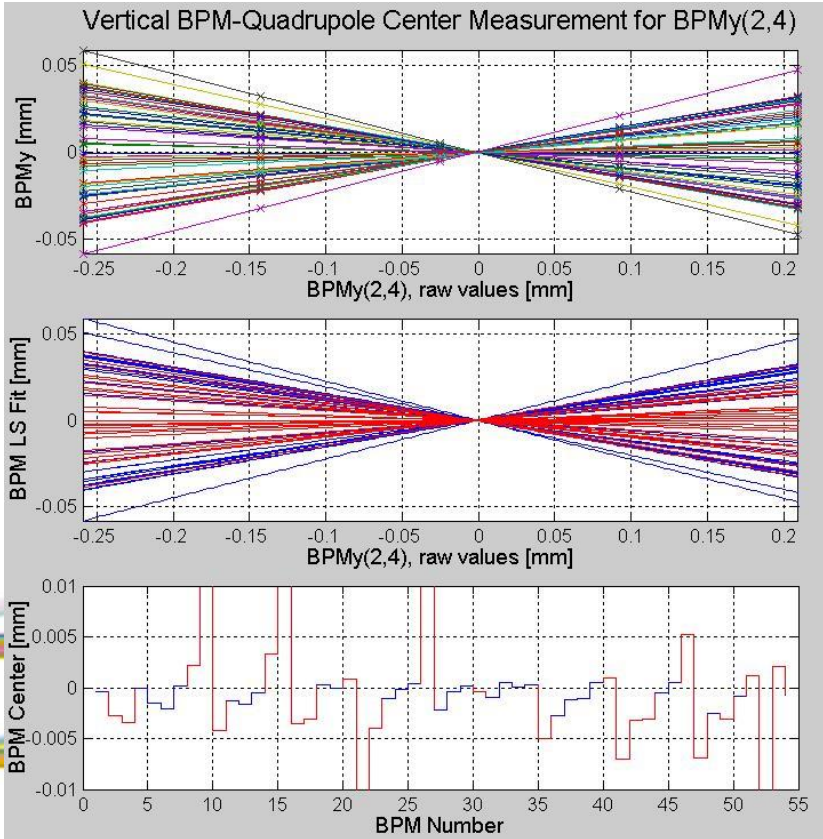

SPEARIII commissioning / 2004

Courtesy J. Safranek



BPM reading @ 5 CM settings

=

5 positions of the beam inside QUAD

Quadrupole centring (BBA)

quadcenter.m

[MATLAB middlelayer]

Diamond

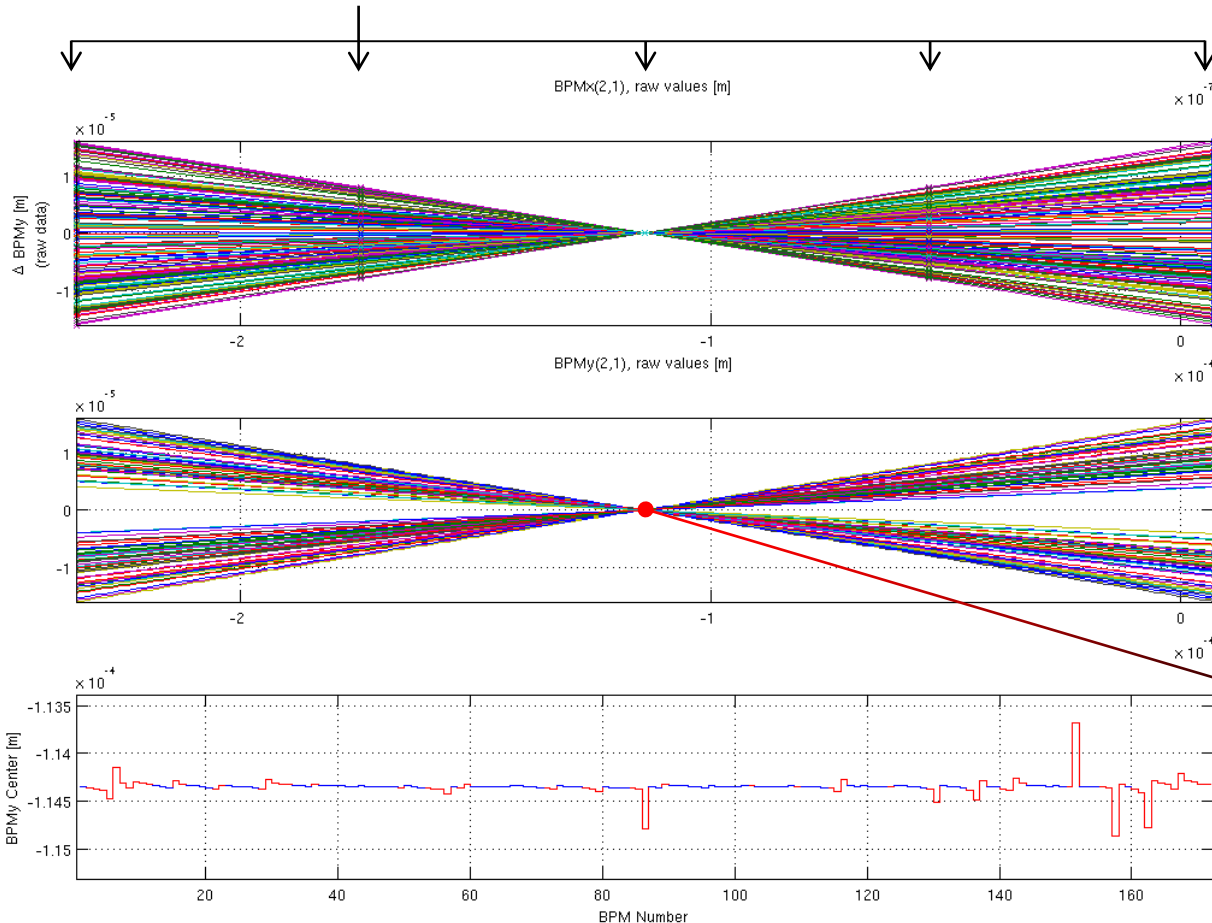

Orbit change from:
 $Q+\delta / Q-\delta$

Data filtering:
 outliers removal
 (e.g. small slope ...)

Centre of QUAD from fit

BBA offsets (Diamond Commissioning, 2006 c.ca)

Large Offsets:

- BPM electrical centres not calibrated
- Not accurate mech. survey

BBA offsets (Diamond 20/3/2015)

Smaller offsets

Diamond

Reproducibility & general issues

~ few 100um in adjacent runs

>few 100um if BPM has been worked on

Current Dependence of BPM response

Heat load on chamber

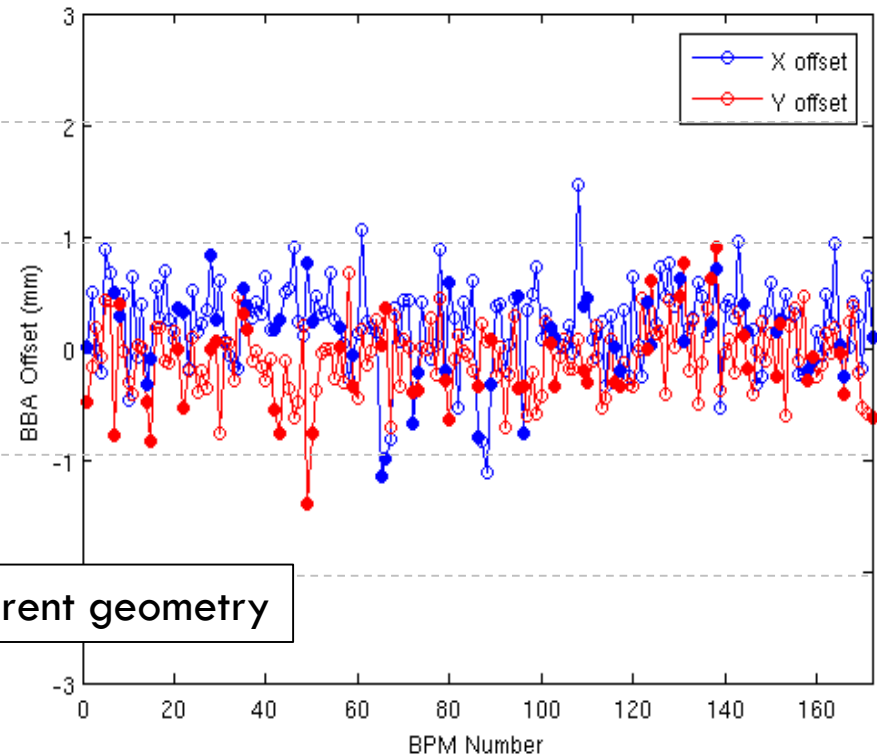
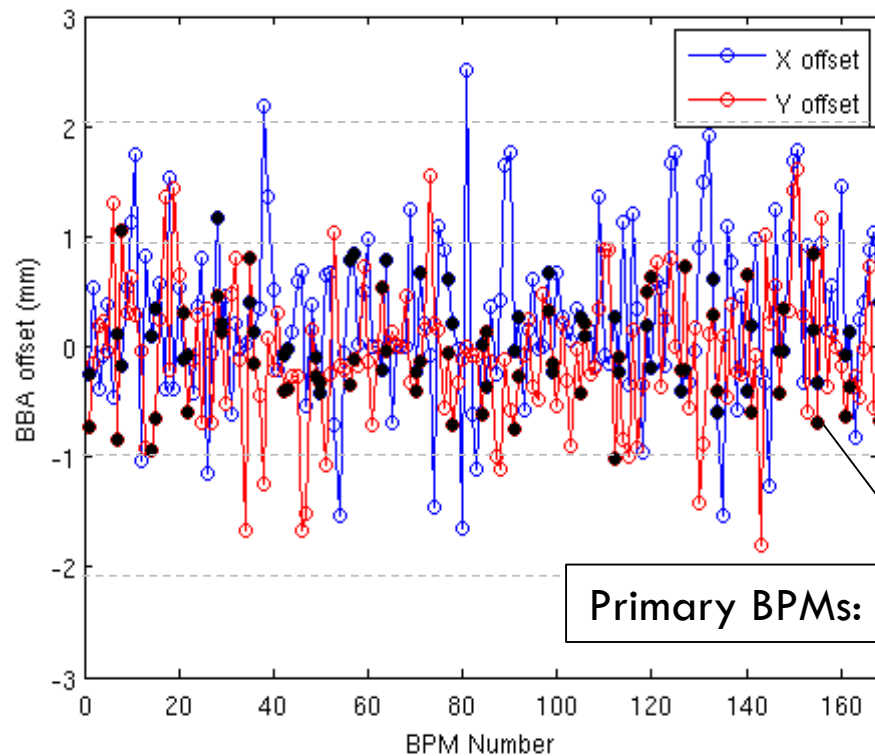

BBA offsets @ SLS : <500um
Reproducibility: <50 um after 2m

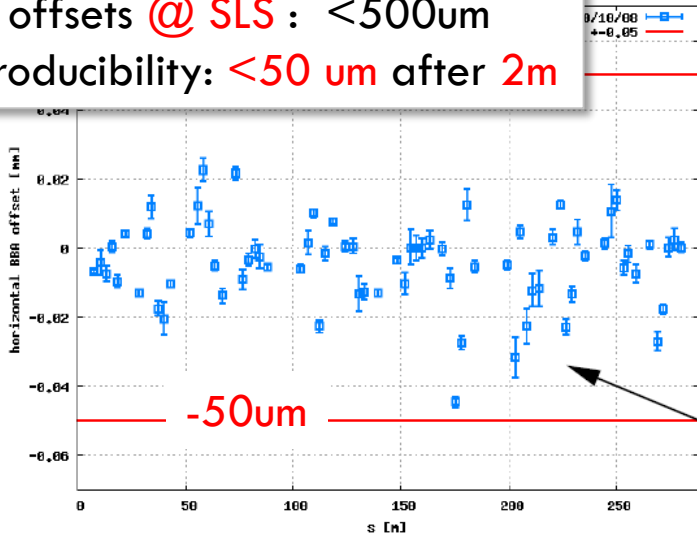

2m stability

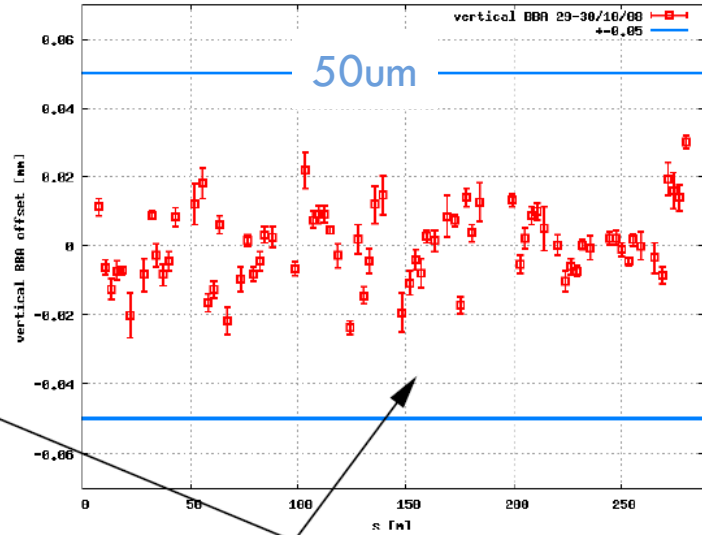

SLS

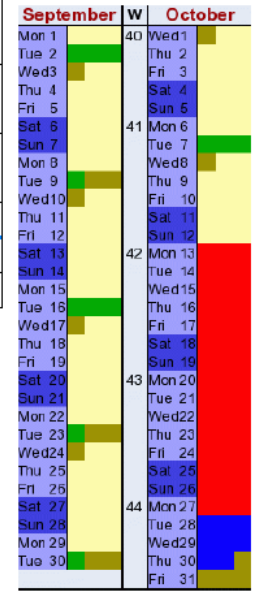

BBA actual offsets

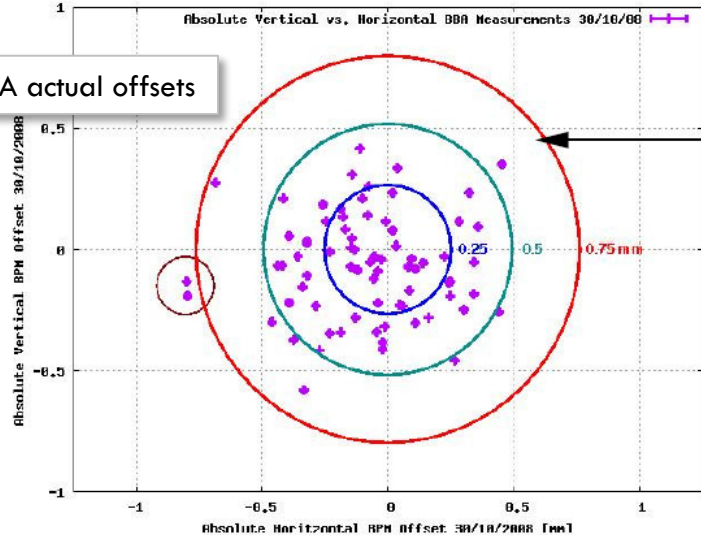

Changes of BBA constants after 2 months of operation and 2 weeks of shutdown (changes stay within a +/-50 um band)

Absolute BBA constants which feature offsets of more than

750 um !

These large offsets are of electronical origin and mechanical origin (vacuum chambers are floating with respect to the quadrupole centers).

How to distinguish between the two contribution ?

Courtesy M. Boge



BBA offsets @ SLS : <500um
 Reproducibility: <50 um after 2m

BBA offsets correlation to
 mechanical displacement

SLS

BBA dx/dy histograms for the SLS

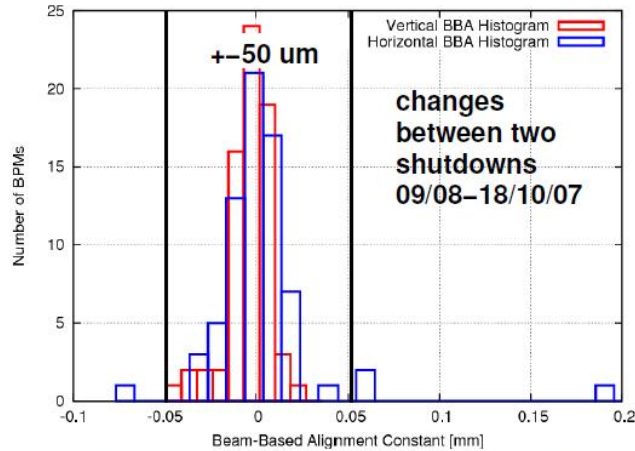

BBA dx/dy error histograms for the SLS

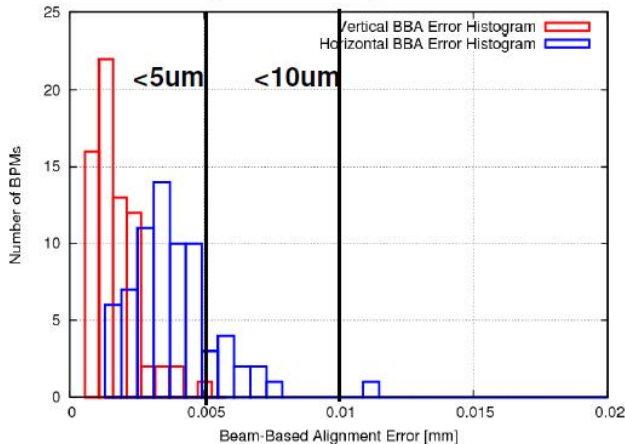

BPM horizontal offsets X0 and measured displacement delta X

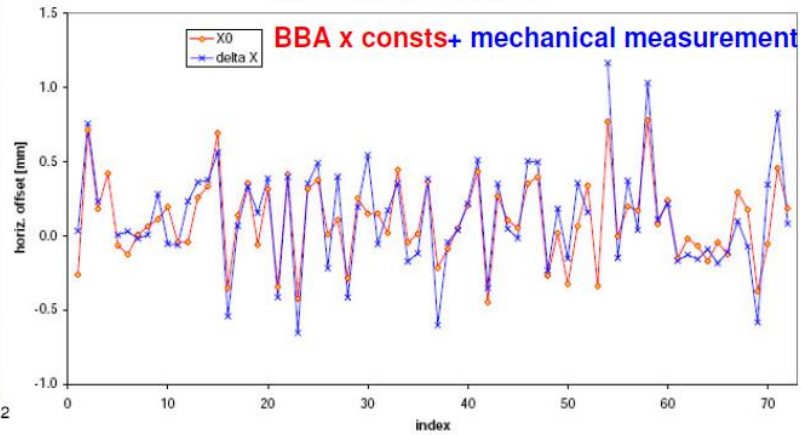

BPM vertical offsets Y0 and measured displacements delta Y

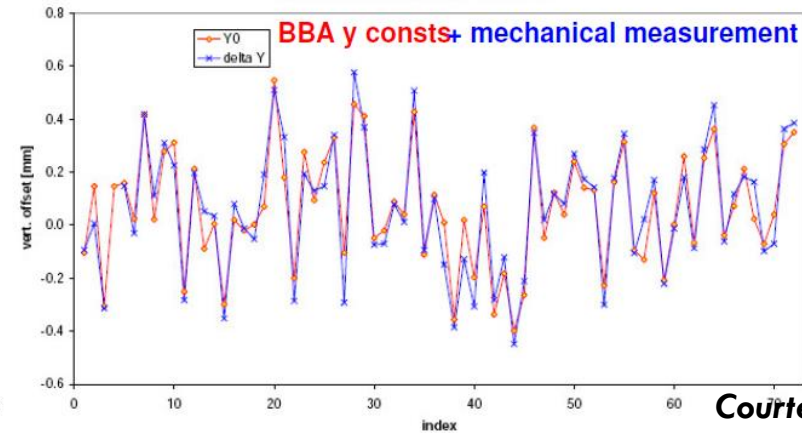

Courtesy M. Boge





Orbit deliberately sent *off axis at sextupoles* to comply with users golden orbit.
Need to know the offset at sextupoles.

LOCO approach extended by defining “virtual” quads and skews at sextupole locations:

- quadrupole fits the H offset @ sextupole:
- skew-quad fits the V offset @ sextupole:

$$K_{quad} = (x-x_0) K_2$$

$$K_{skew} = -(y-y_0) K_2$$

Procedure:

- scan sextupole by family (S1 – S4)
- measure ORM
- fit the quadrupole and skew quadrupole component
- linear fit on the gradient to find the H and V offsets at the sextupoles

V. Sajaev et al. / Proc. IPAC10, THPE091

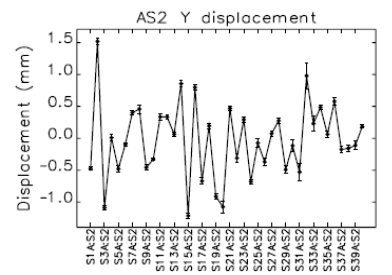
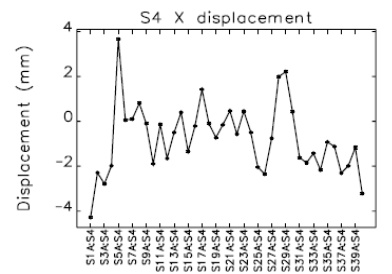
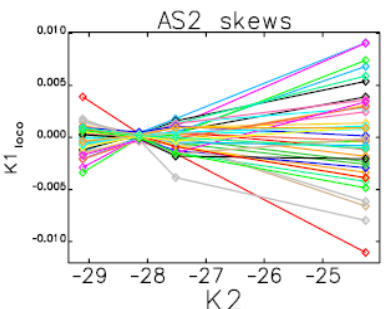
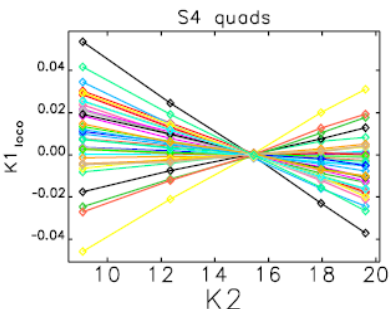

further developed @ ASLS

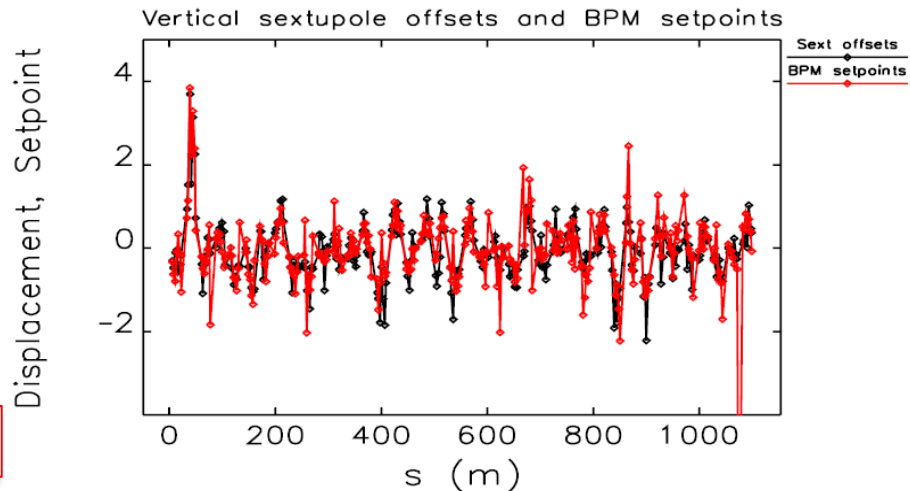

Clean linear machine (LOCO). Main target is the **V offset in sextupoles** individually to reduce the V emittance. Instrumental in achieving the quantum limit 0.35 μm

ASLS

V offsets used to shim each individual magnet on the girder (sextupoles found systematically lower vertically). Shim units of 25 μm , max shim reached $\sim 150 \mu\text{m}$ in many cases

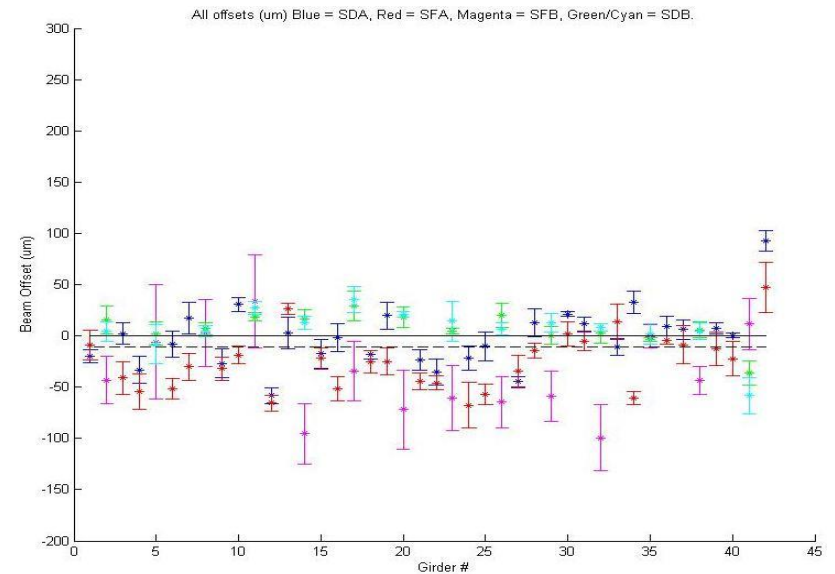
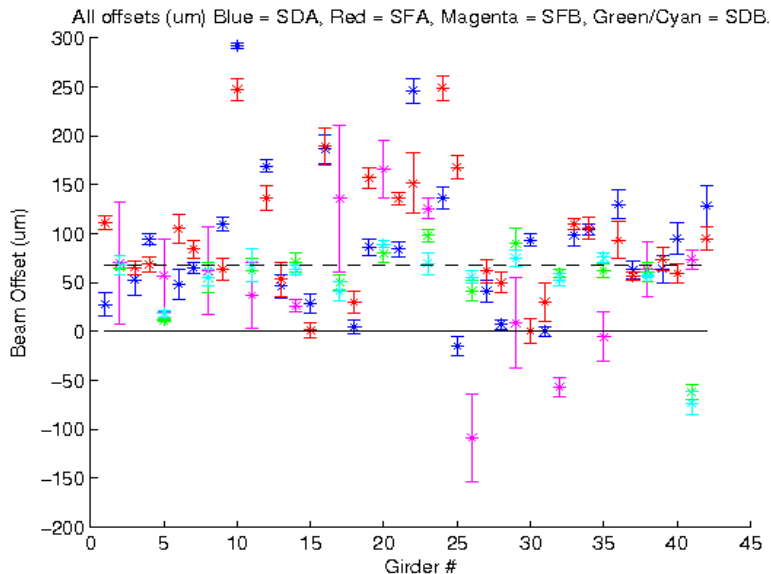

R. Dowd et al. / Proc. IPAC13, TUPWA003

Shimming sextupoles for V alignment at ASLS



ASLS

Lattice Conditions	Uncorrected ε_y (pm)	Minimized ε_y (pm)
Uncorrected	36.8 ± 5.9	8.3 ± 2.3
Uncorrected, sextupoles off	30.4 ± 4.8	6.0 ± 1.4
Sextupoles corrected	35.8 ± 6.2	5.4 ± 1.9
Sextupoles and quadrupoles corrected	12.8 ± 2.4	0.34 ± 0.06

Courtesy R. Dowd

$$K_{\text{skew}} = \sin(\theta/2) K_1$$

ASLS

ramp **sextupoles** down to **zero gradient (!)**

Vary K_1 and measure **ORM**

→ LOCO

→ find K_{skew}

→ infer θ_{quad}

Define **girder roll** as **average** of θ_{quad}

Roll girders to reduce coupling

Lattice Conditions	Uncorrected ε_y (pm)	Minimized ε_y (pm)
Uncorrected	36.8 ± 5.9	8.3 ± 2.3
Uncorrected, sextupoles off	30.4 ± 4.8	6.0 ± 1.4
Sextupoles corrected	35.8 ± 6.2	5.4 ± 1.9
Sextupoles and quadrupoles corrected	12.8 ± 2.4	0.34 ± 0.06

Courtesy R. Dowd

SLS found (2010) quadrupole misalignments are dominated by **girder misalignments**
(correlation in offset of individual quads on the girder)

SLS

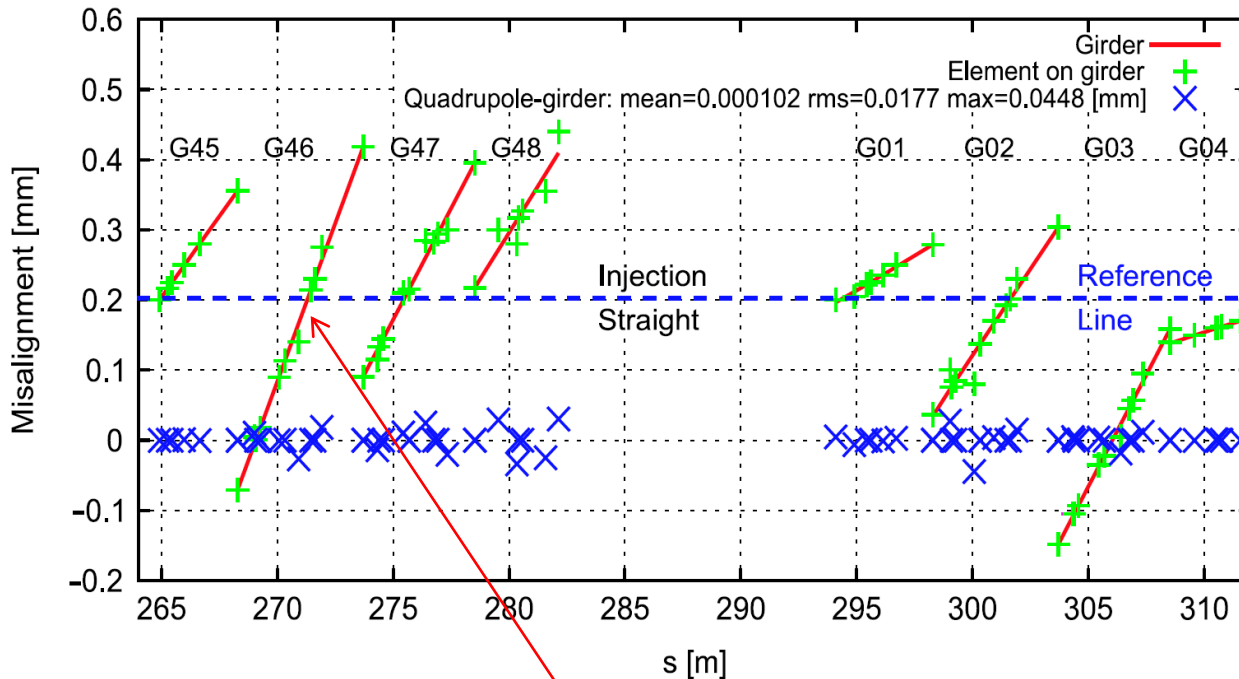

M. Aiba et al. / Nuclear Instruments and Methods in Physics Research A 694 (2012) 133–139

Fit to individual magnet positions

Diamond: large **girder misalignments** both in the H and V plane

Survey August 2013

H-plane

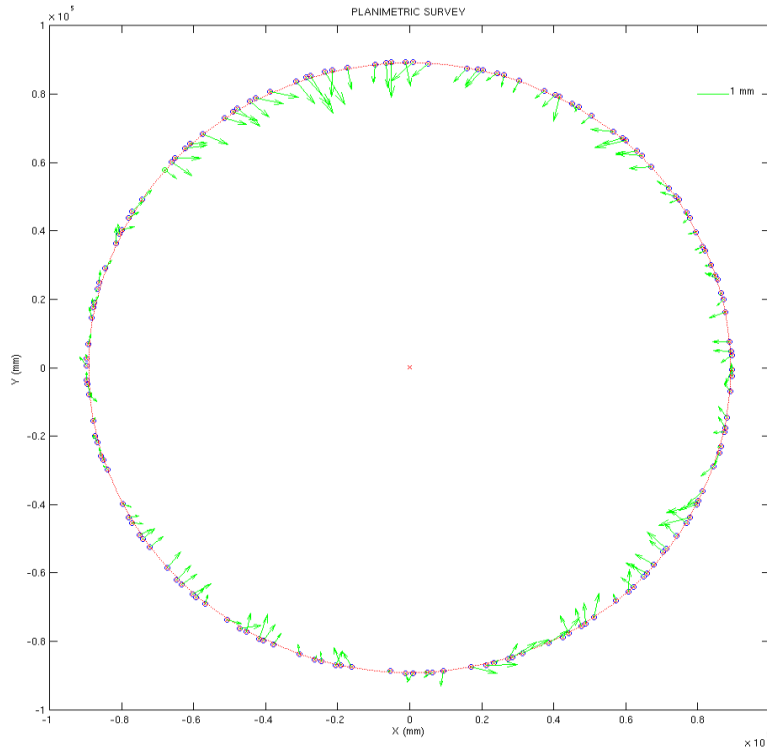

Survey January - August 2013

V-plane

Diamond

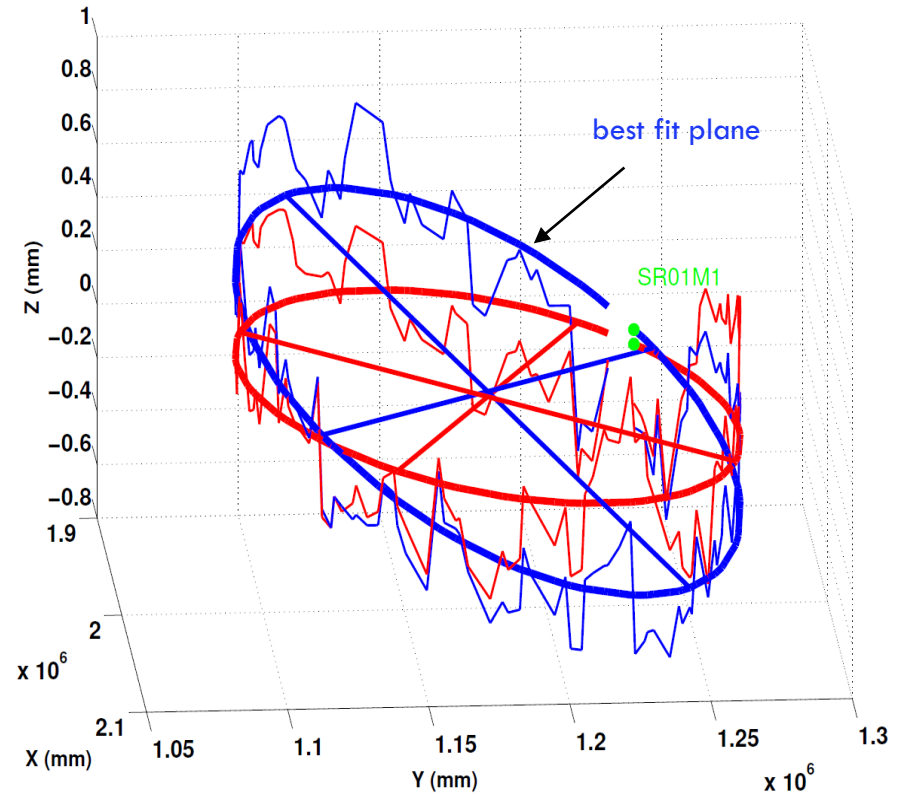

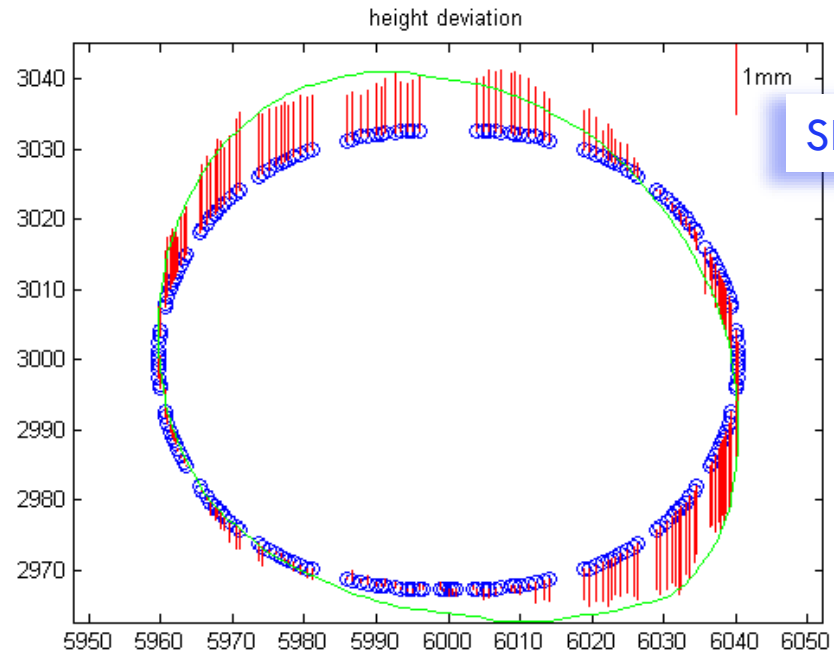
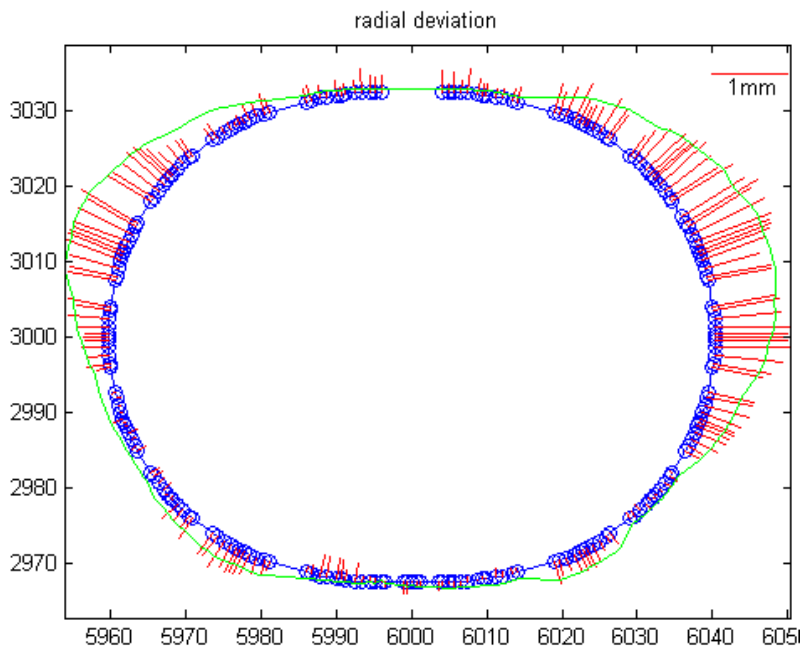

SPEARIII

Courtesy J. Safranek

Smooth Curve (SC):

- badly mis-aligned magnets **individually re-aligned wrt SC** (~every yr)
- beam-lines follow the re-alignment
- recent re-alignment (summer 2014):
 - easy injection
 - CM corrector reduction
 - skew quad strengths reduced

SLS observed a characteristic pattern in correctors adjacent to **misaligned girders**.

Misalignments cause: **V dispersions** and **orbit distortions**

SLS

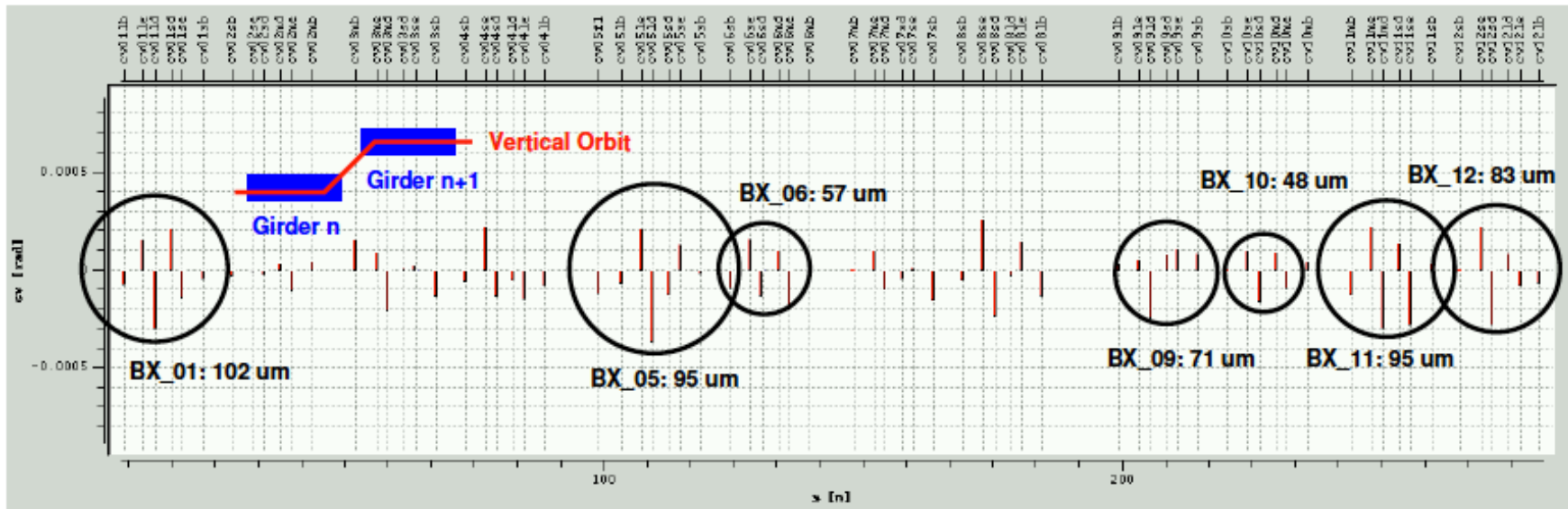

Courtesy M. Boege

- Corrector Pattern can be used to determine alignment errors (→No Cutoff).
- Prominent girder-girder alignment errors related to local corrector patterns (circles).
- Girder-girder errors introduce mechanical steps driving the adjacent correctors.
- Leads to saturation of correctors in machines with large alignment errors (→Eigenvalue Cutoff = “Long Range Correction”).

Magnet mounted rigidly onto girders ("MAX-2 concept")

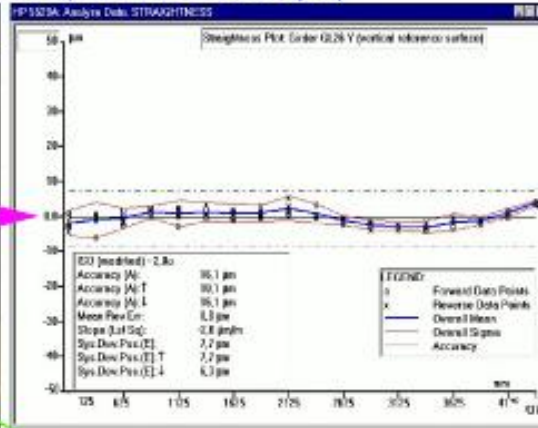
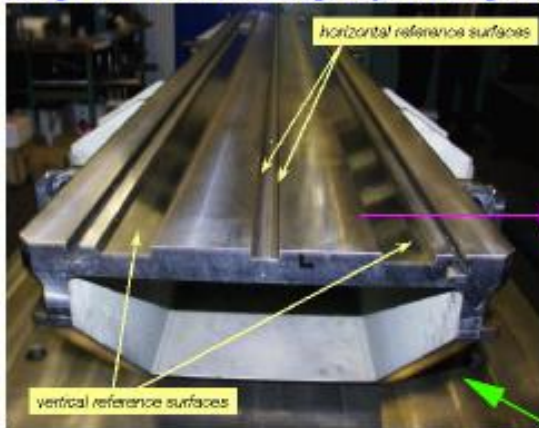

Girders movable in 5 degrees of freedom
Position monitoring systems on girders

Girder Rail Precision: 15 µm
Magnet Axis Calibration: 30 µm

Remotely Controlled Girder Movers
-> "Beam-Based Girder Alignment"

12 sectors x 4 girders + 1 FEMTO girder = 49

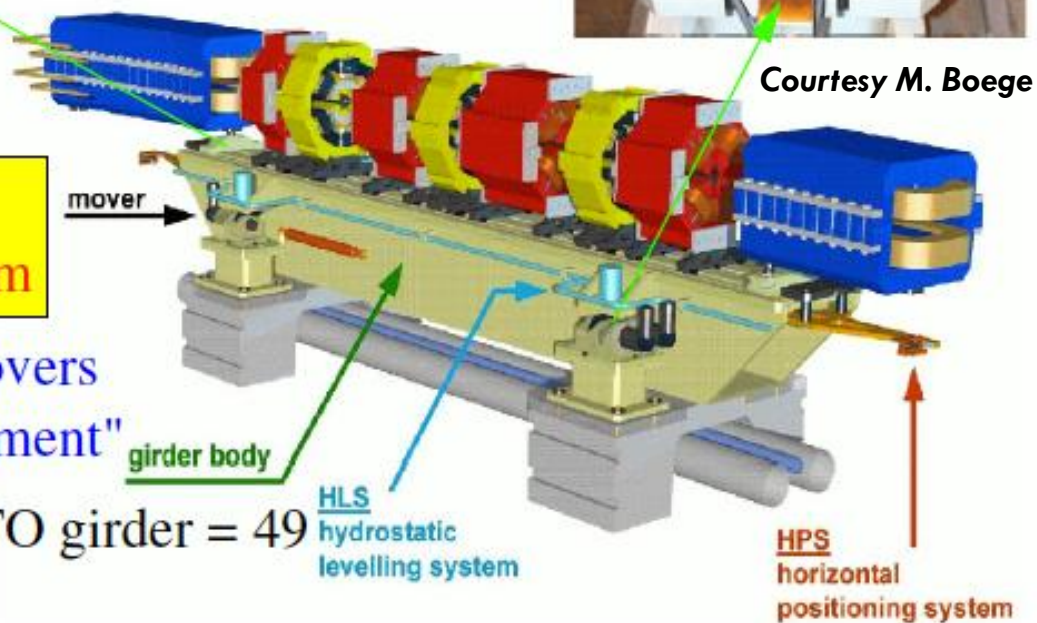

Courtesy M. Boege

SLS

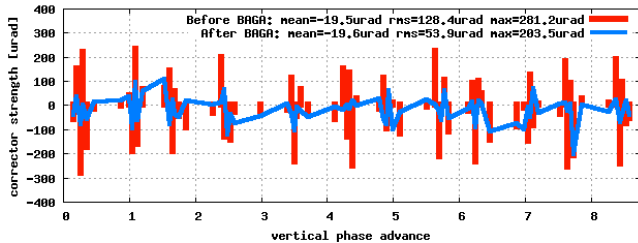
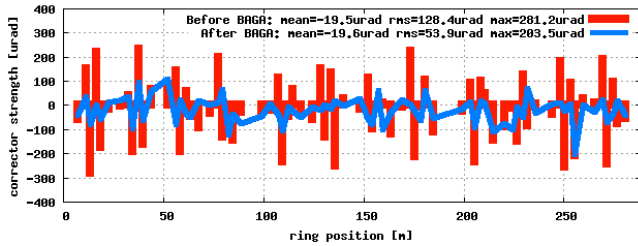

-girders moved according to heave/pitch fits from quad survey data

-FOFB on and beam in the SR

-Actual girder move inferred from CM variations (online) ← BAGA

M. Boege et al. / Proc. IAPC13, WEPME047

-Procedure “refined” with final quad-BBA

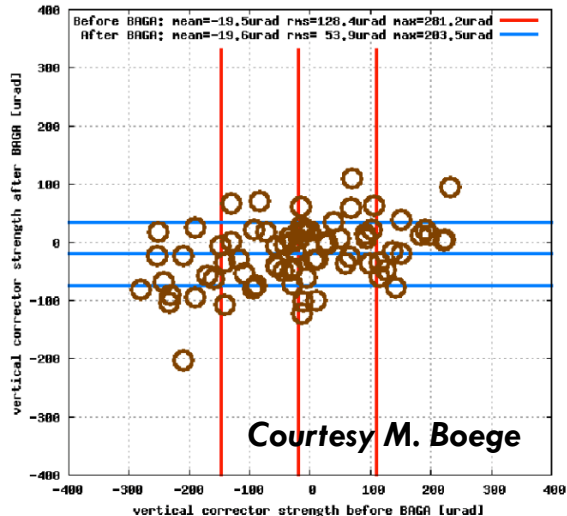
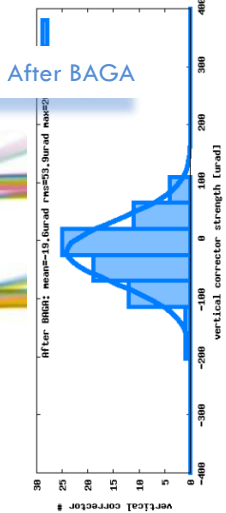
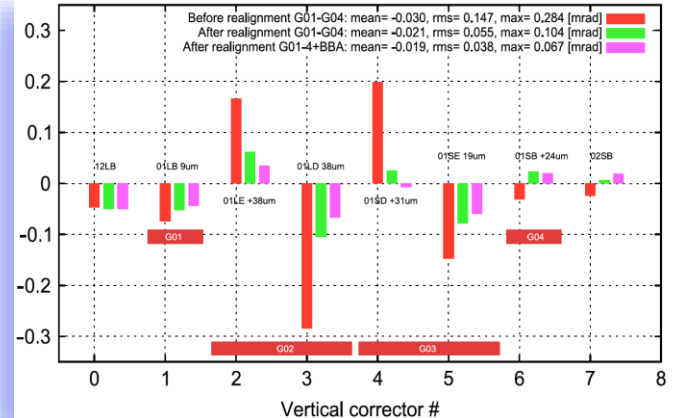
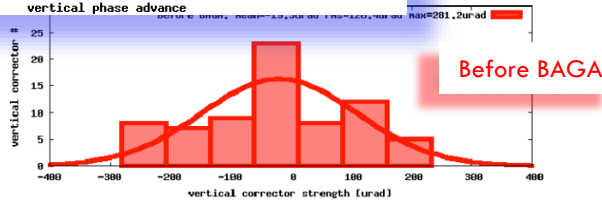

Girder realignment instrumental in reducing the vertical ϵ_y down to 0.9 pm. New BAGA campaign foreseen based on 2013 survey data



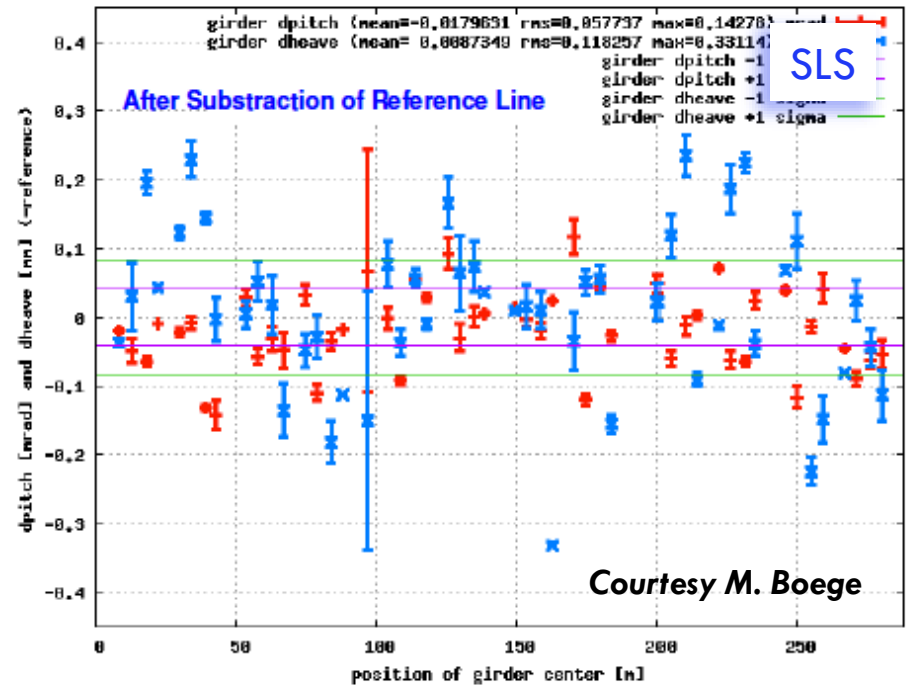
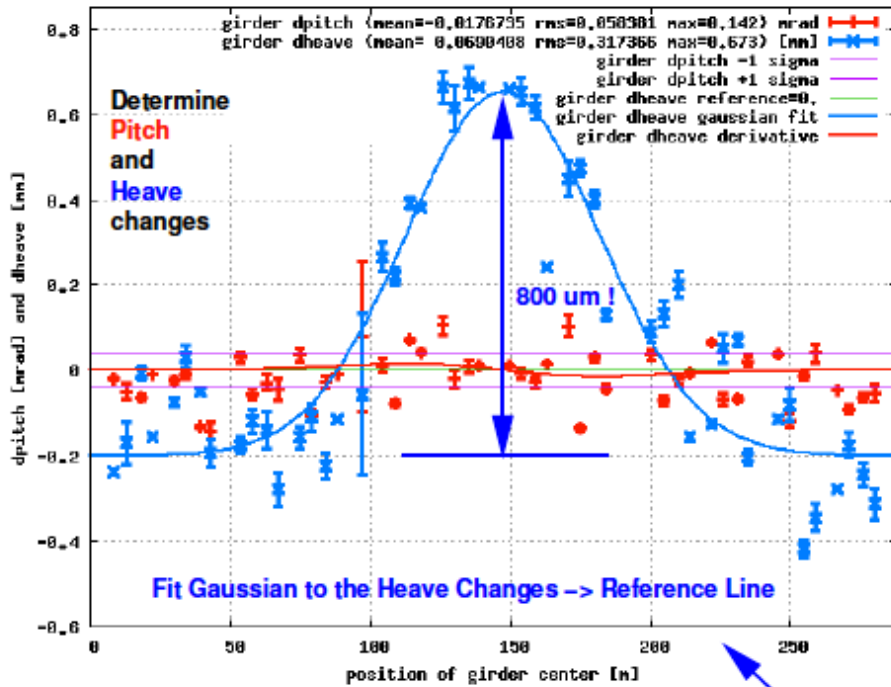

Courtesy M. Boege

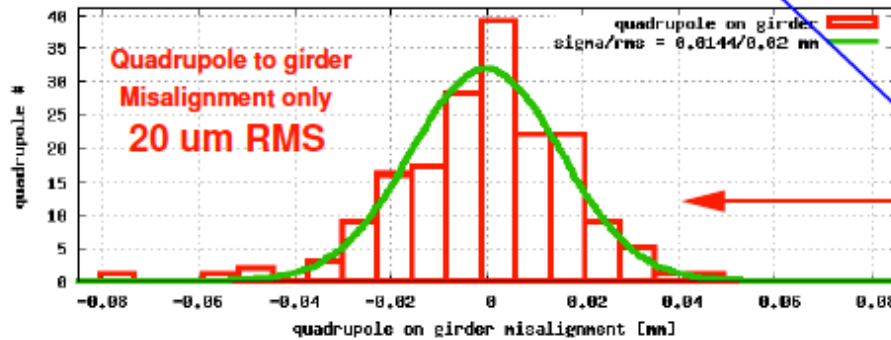

Vertical Quadrupole Alignment Data from 2010 (Courtesy K.Dreyer et al) !

Girder Fit to Quadrupole Misalignments

Determine Pitch and Heave Changes

Determine Quadrupole to Girder Misalignment

Adjust Girders to Reference Line

With Beam and Fast Orbit Feedback On !

Beam Assisted Girder Alignment

-56 girders, each equipped with a 3-pot HLS system to monitor long term vertical variations

- plan to lower coupling for users → vertical re-alignment under discussion (for 2015)

- no sextupole re-alignment so far

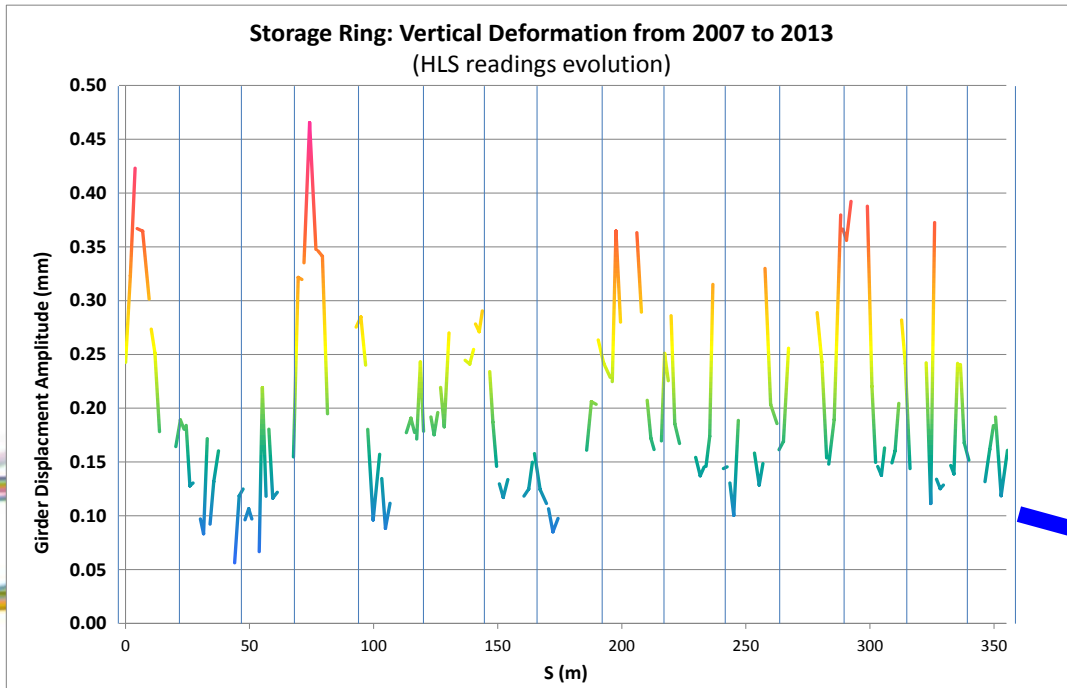

Courtesy L. Nadolski

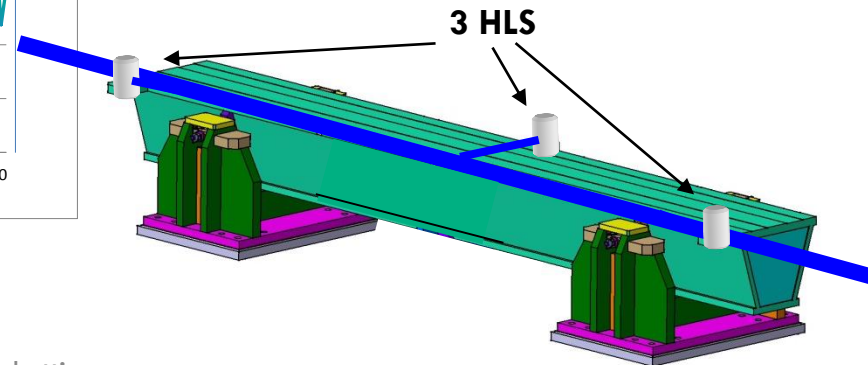

24 cells x 3 girders + 2 girders (mini-beta sections) = 74 girders

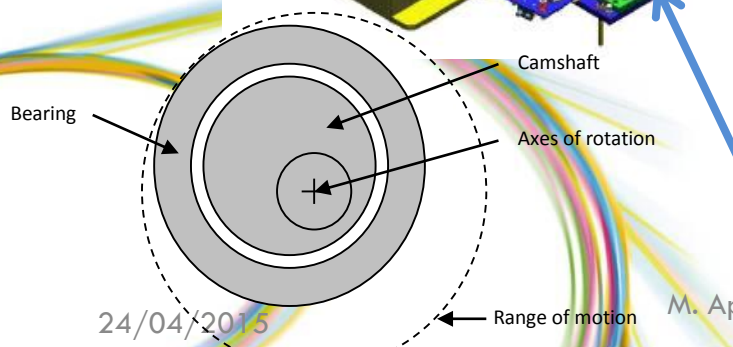
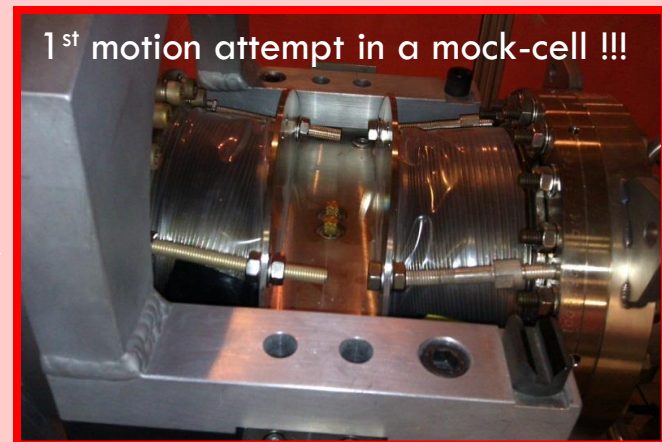
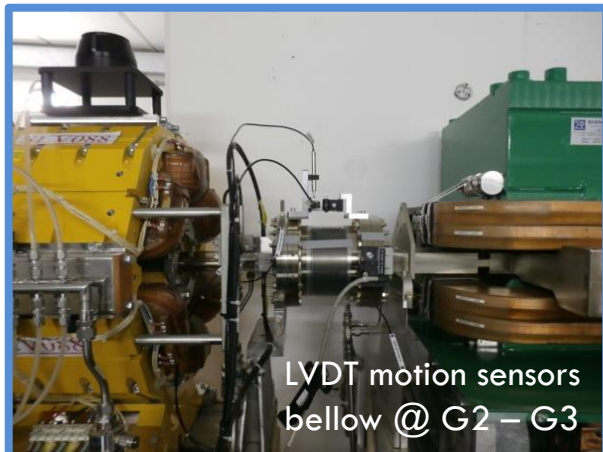
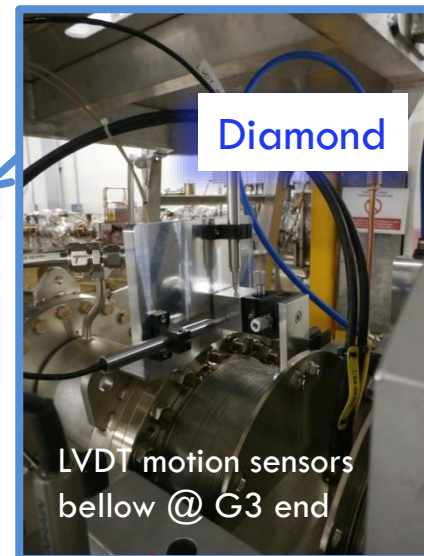

24/04/2015

M. Ap

Initial tests with single girder moves ...

Diamond

VC8G2

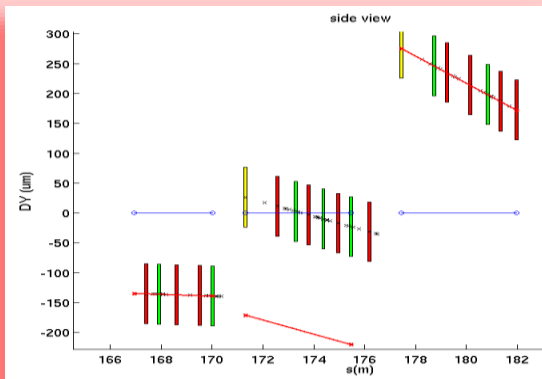
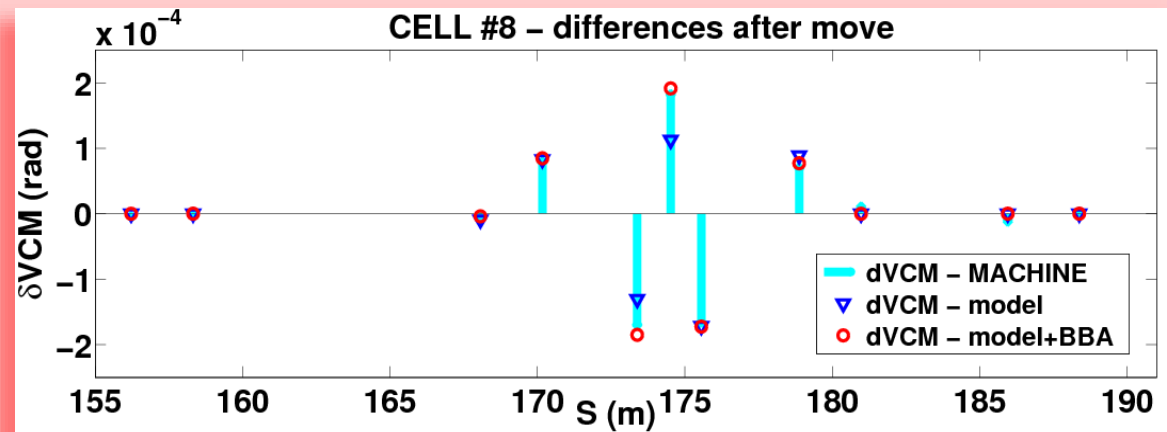
heave=+197 μ mSurvey Assisted Girder Alignment
SAGA

CM variation correctly reproduced when **BBA corrections** are introduced in the model (as done in the machine)

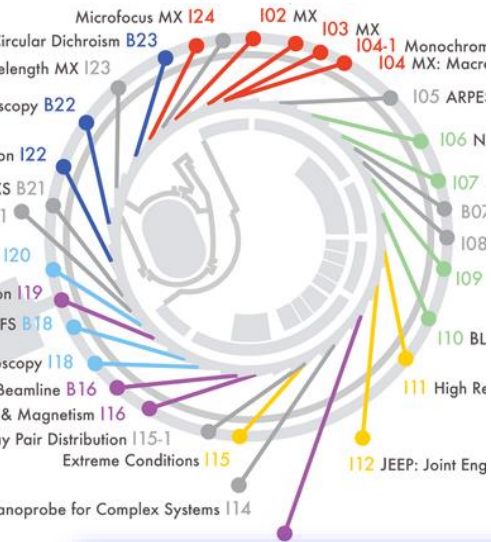

- Diamond is a **densely populated** environment
- leading idea: **re-align SR with no impact** on operating **beamlines**
- orbit variations compensated by **Golden Offsets at primary BPMs**
- initial single girder tests
- now **remotely controlled system (a la SLS)** for **multi-girder moves**
(cells 4, 5 & 6 equipped and commissioned)



Diamond

TR at BL-I05: BBA (1) and orbit restoration via Golden Offset (2)

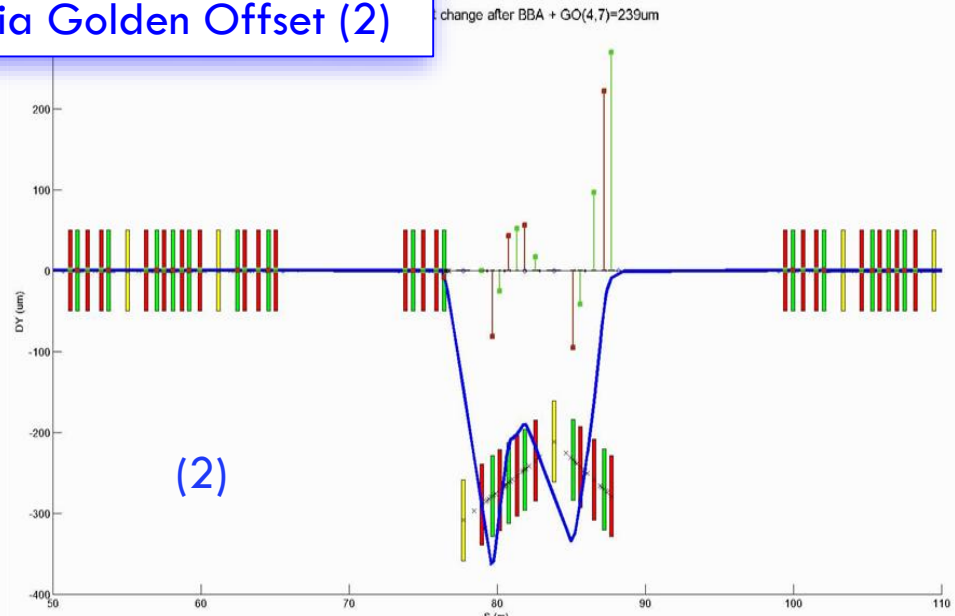
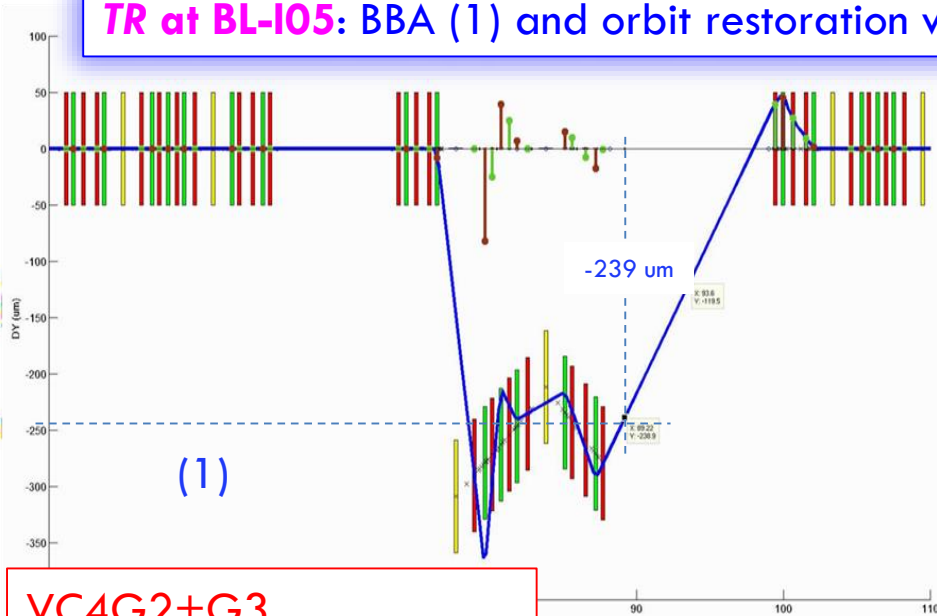

VC4G2+G3
 heave G2 = -275 um G3 = -250 um
 pitch G2 = 15 urad G3 = -17 urad

TR at BL-I05

0) initial configuration

19/12/2014

- C4G2G3 moved
- BBA
- GO → transparent to BL

8/4/2015

- C5G1G2 moved
- BBA
- Remove all GOs
- Re-align beamline

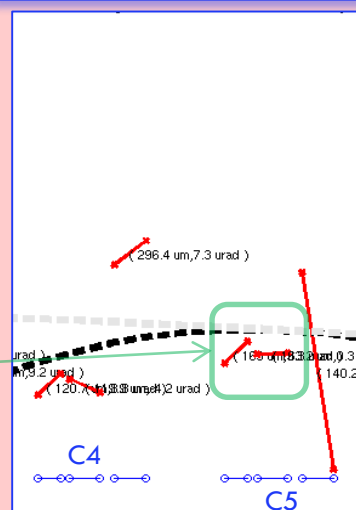
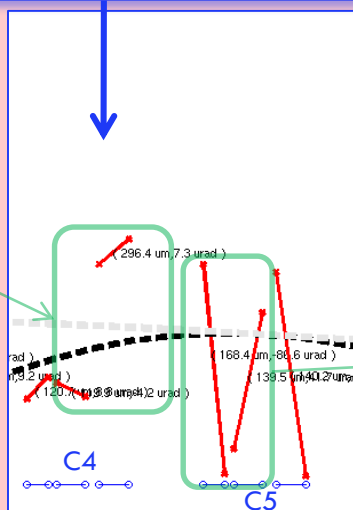
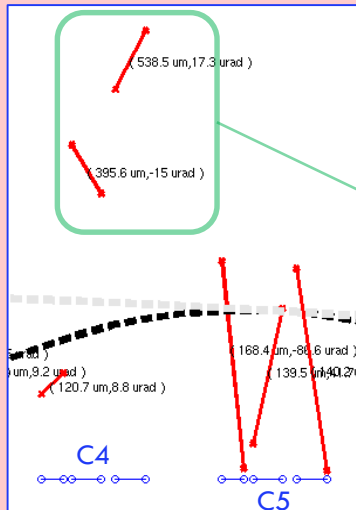

Significant VCM reduction

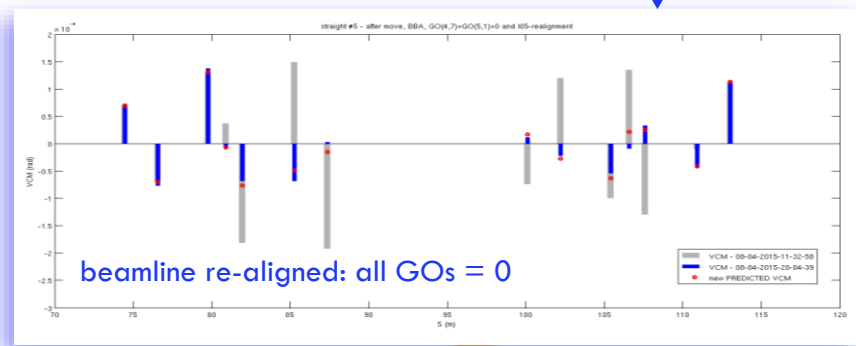
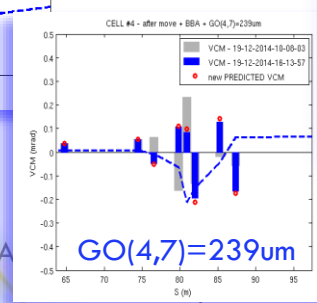
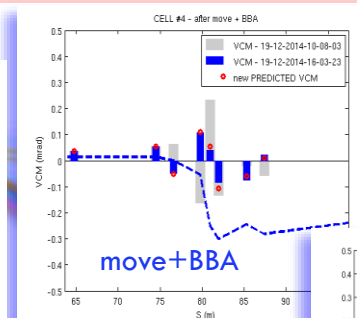
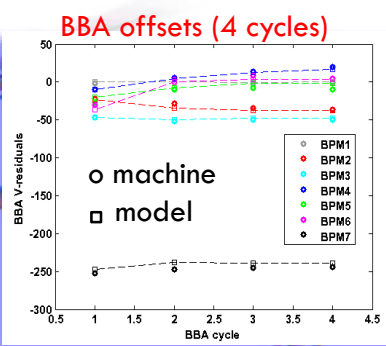

Very good agreement Model vs Machine

A collection of tools for **beam based alignment** is available and has been well tested at several different light sources

ORM technique at ASLS shows that **sextupole** horiz. and vert. **offsets** can be measured with beam to an accuracy of 10-50 μm depending on magnet location. Together with quadrupole roll measurement and **girder roll correction**, this was instrumental to **reduce ε_y (\sim quantum limit)**

Girder alignment with remote control proven at SLS (important to **reduce vertical emittance to 9pm**).

Encouraging results being obtained at **Diamond**.

Beam based alignment techniques can potentially achieve measurements of the magnetic centre of magnets to precision comparable to the best bench-top techniques

Thanks for your attention ...

LOCO: off diagonal sector of the ORM to fit a number of machine parameters such **BPM gains** and **coupling**.

BPM rolls from
LOCO @ Diamond

Inclusive measurement of BPM **mechanical rolls** and **electrical cross talk** between the X and Y electronics channels

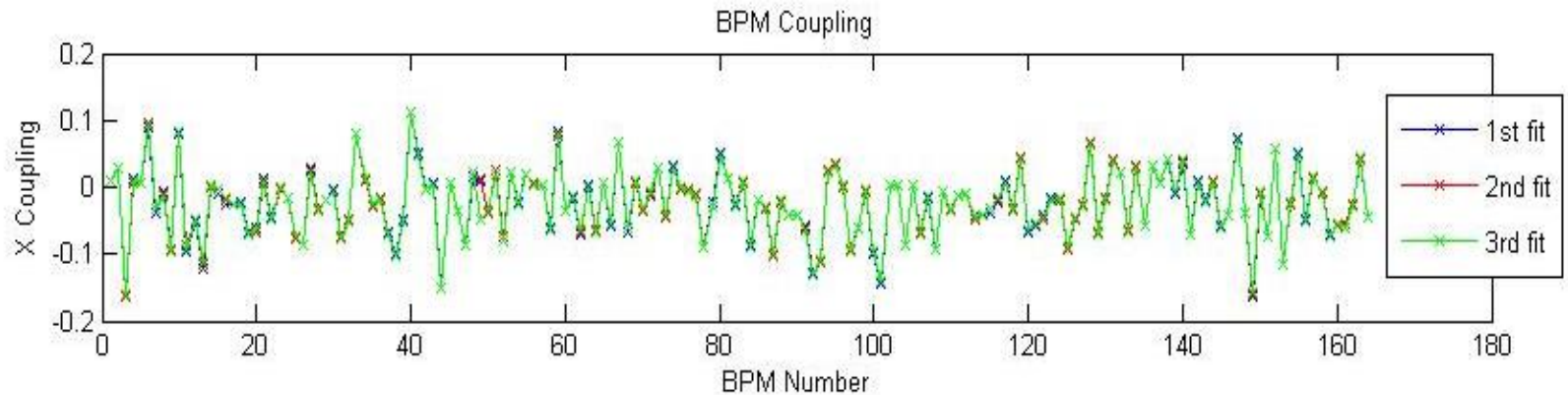

Courtesy R. Bartolini

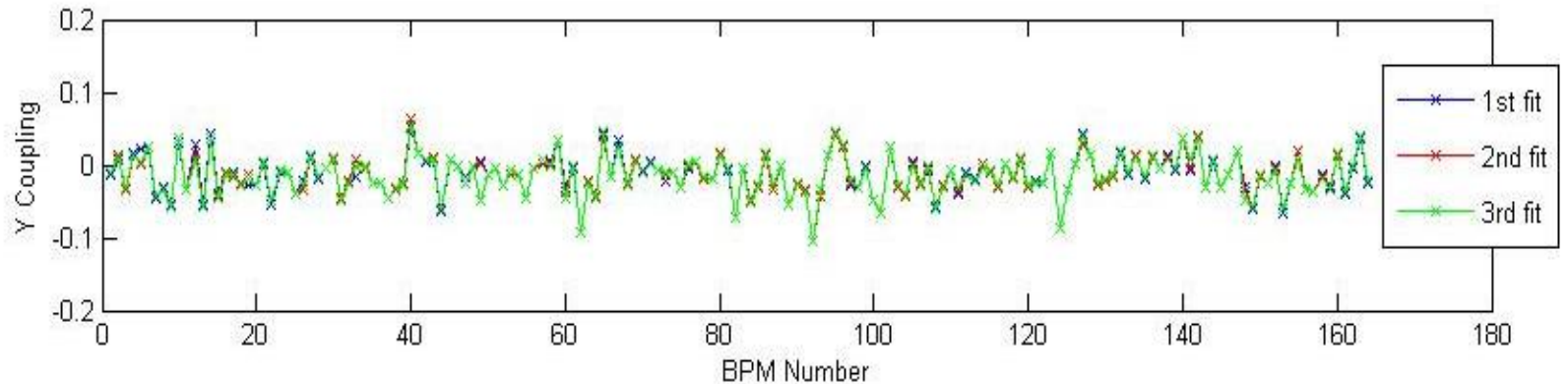

Similar analysis based on **in-house software**. Measured via corrector pattern analysis: exciting V orbit bumps at each BPM and measuring H correctors

BPM rolls from
Orbit cross-talk @ SLS

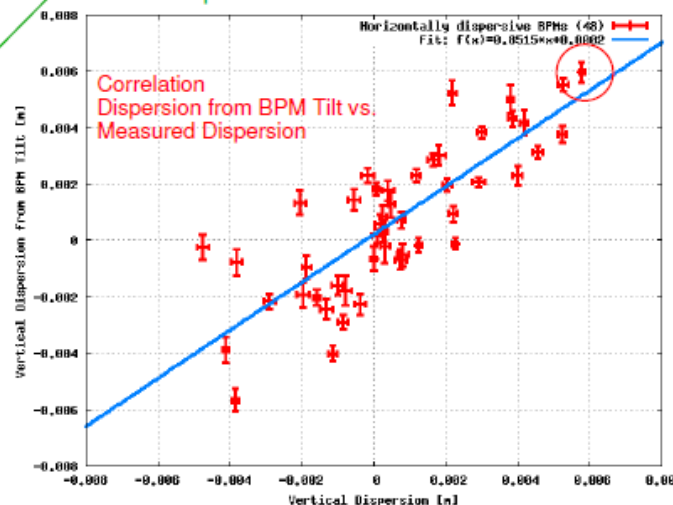
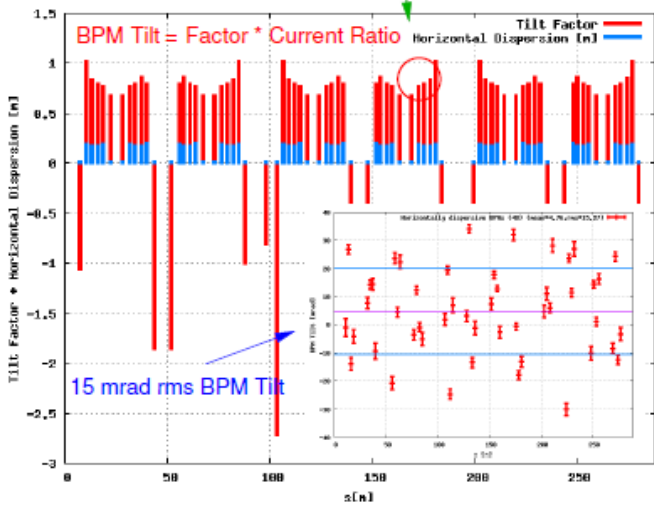
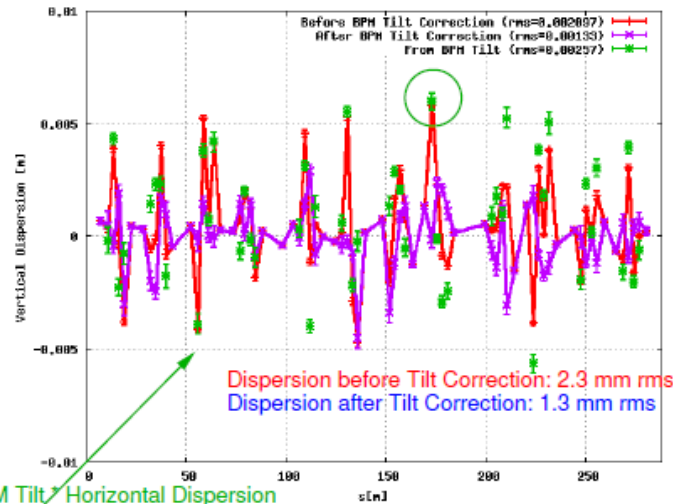
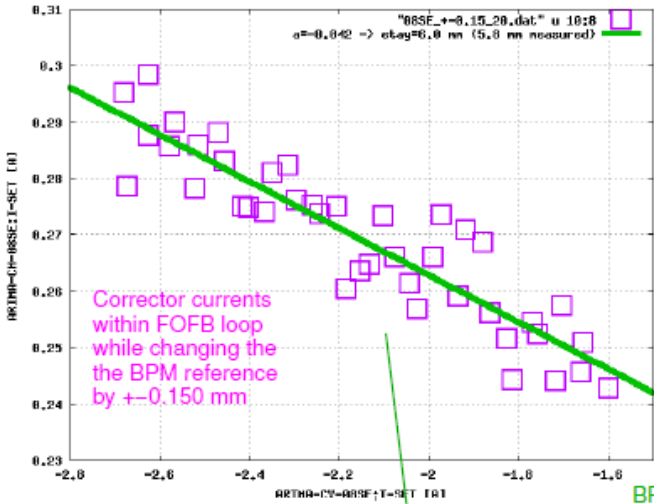

Dispersion function looks more like a betatron wave after cross talk correction

Results cross checked with LOCO

Courtesy M. Boge



TR at BL-I05 (19122014): effect of orbit tilt on I05 energy peaks (SHADOW simulation)

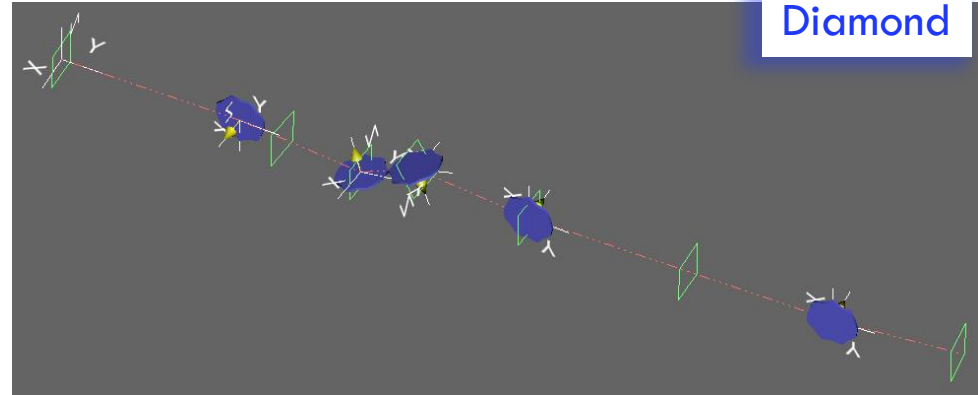
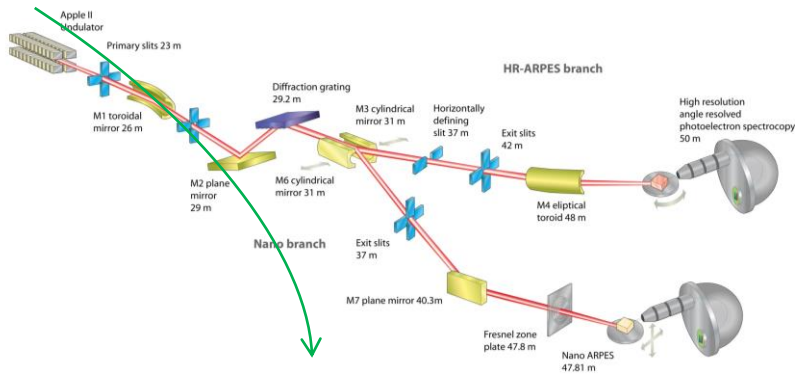

command: plotxy,screen.0502,3,1,XRANGE=[-0.0150000,0.0150000],YRANGE=[-0.0150000,0.0150000],NLOST=1,NBINS=400,
/dls/physics/xph53246/test/TRANSPARENT_REALIGNMENT/BEAMLINES/I05-MD14102014/screen.0502 Thu Nov 6 09:24:38 C

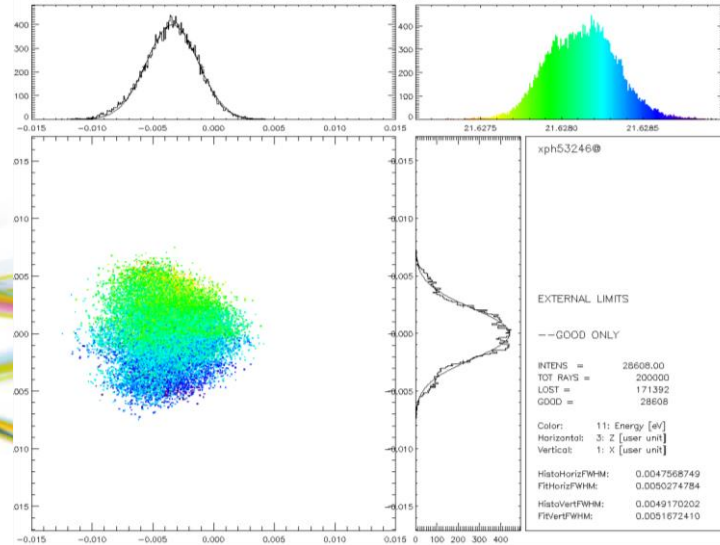

command: plotxy,screen.0502,3,1,XRANGE=[-0.0150000,0.0150000],YRANGE=[-0.0150000,0.0150000],NLOST=1,NBINS=400
/dls/physics/xph53246/test/TRANSPARENT_REALIGNMENT/BEAMLINES/I05-MD14102014/screen.0502 Thu Nov 6 09:27:02 C

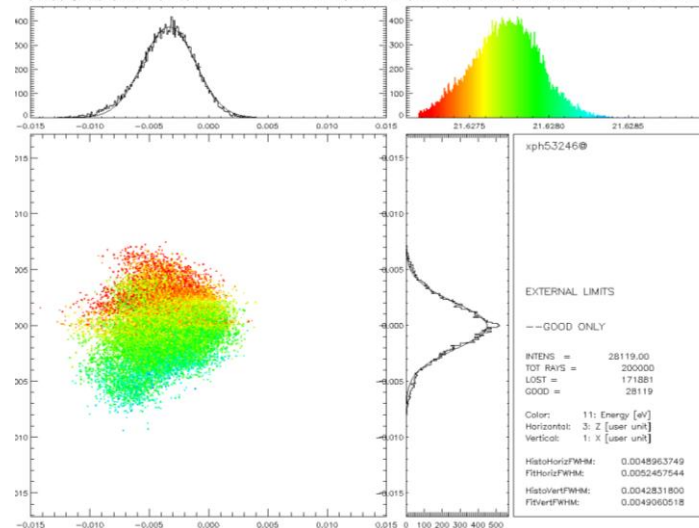

TR at BL-I05

0) initial configuration

1) move + BBA

2) Set GO bump → restore initial orbit

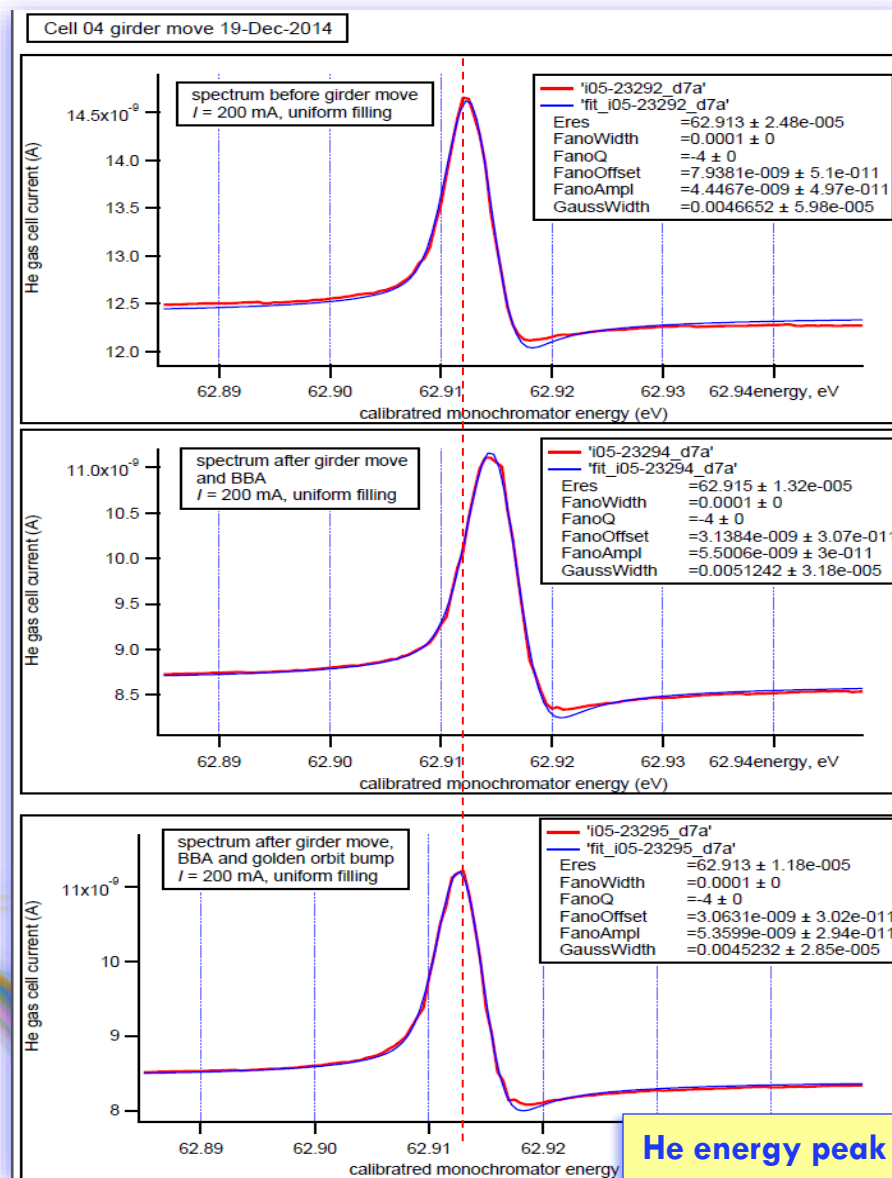

A) Before move

E = 62.913eV

GauB width = 4.665meV

B) After move+BBA

E = 62.915eV

DE = +2 meV

GauB width = 5.124meV

C) Orbit re-stored inside ID05

GO(4,7) = 239um

E = 62.913eV

DE = 0 meV

GauB width = 4.523meV

He energy peak @ I05
Perfectly restored