



MBA Designs : Contents

Outline

Introduction to lattice design

Longitudinal gradient in the bendings

Concept for Diffraction Limited Light Source

Green field projects:

MAX-IV and Sirius

Upgrading processes:

ESRF, APS, ANKA, ALS, ELETTRA, SLS

DBA - Structure

DBA -Lattice

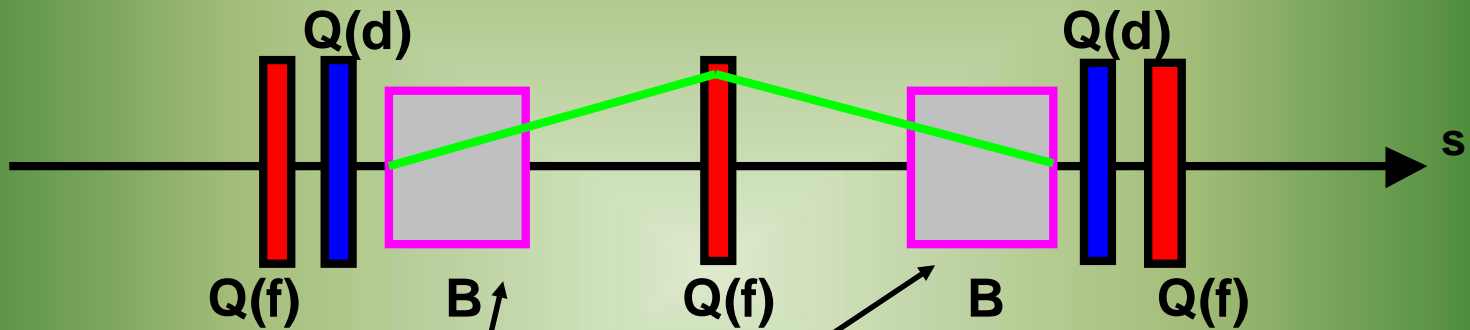

$$\beta_{\min} = L_{\text{mag}} \cdot \frac{\sqrt{3}}{8\sqrt{5}}$$

$$s^* = \frac{3}{8} L$$

Beta(x,s)

Disp(s)

With β_{\min} and s^* the emittance for the DBA-lattice is:

$$\varepsilon_x = C_q \cdot \gamma^2 \cdot \frac{1}{J_x} \cdot \frac{1}{4\sqrt{15}} \cdot \varphi^3$$

In reality however it is a factor 3 to 4 higher.

TME - Structure

TME –Lattice gives the smallest emittance

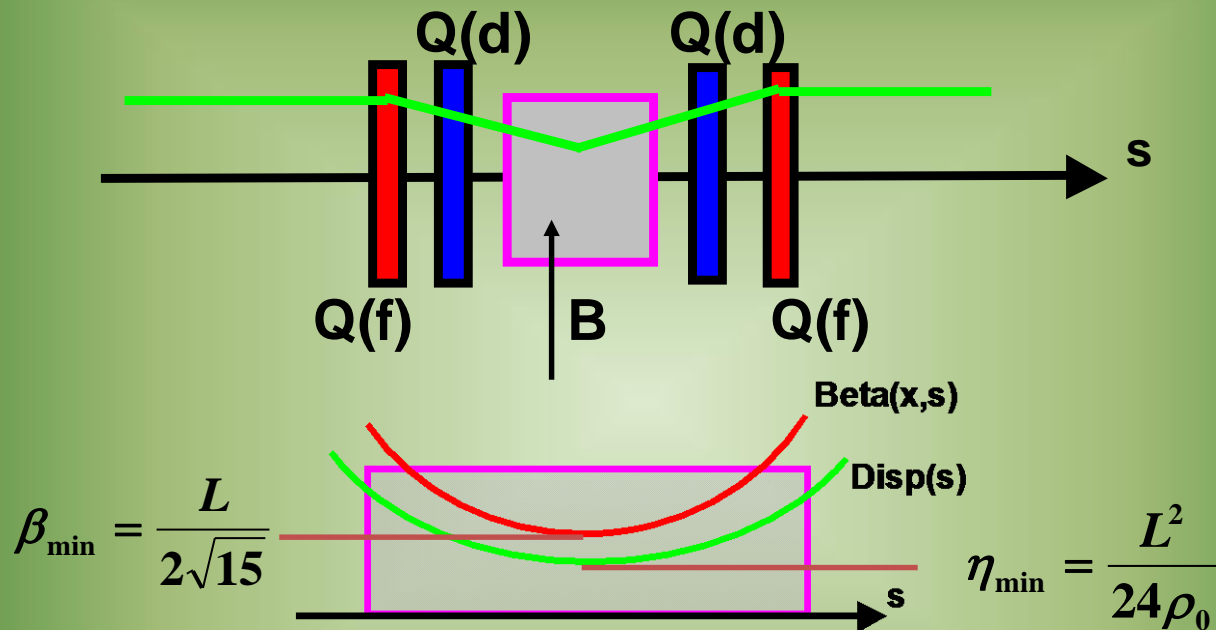

$$\varepsilon_x = C_q \cdot \gamma^2 \cdot \frac{1}{J_x} \cdot \frac{1}{3} \cdot \frac{1}{4\sqrt{15}} \cdot \varphi^3$$

The emittance is by a factor of 3 smaller as for the DBA structure

Introduction to Lattice Design

$$\epsilon_{horizontal} = \frac{55}{32\sqrt{3}} * \frac{\hbar}{mc} * \gamma^2 * \frac{\langle \frac{1}{\rho^3} H(s) \rangle}{J_x \langle \frac{1}{\rho^2} \rangle}$$

$$Cq = 1.47 * 10^{-6} \text{ [m/(GeV}^2\text{)]}$$

$$H = \beta \eta'^2 + 2\alpha \eta \eta' + \gamma \eta^2$$

$$\epsilon_{hor} \text{ (nmrad)} = 1470 * \frac{(E / \text{GeV})^2}{J_x} * \frac{\Phi^3}{12 * \sqrt{15}} * F$$

$$\epsilon_{hor} \text{ (nmrad)} = 31.63 * \frac{(E / \text{GeV})^2}{J_x} * \frac{\Phi^3}{1} * F$$



Longitudinal Bending Gradient

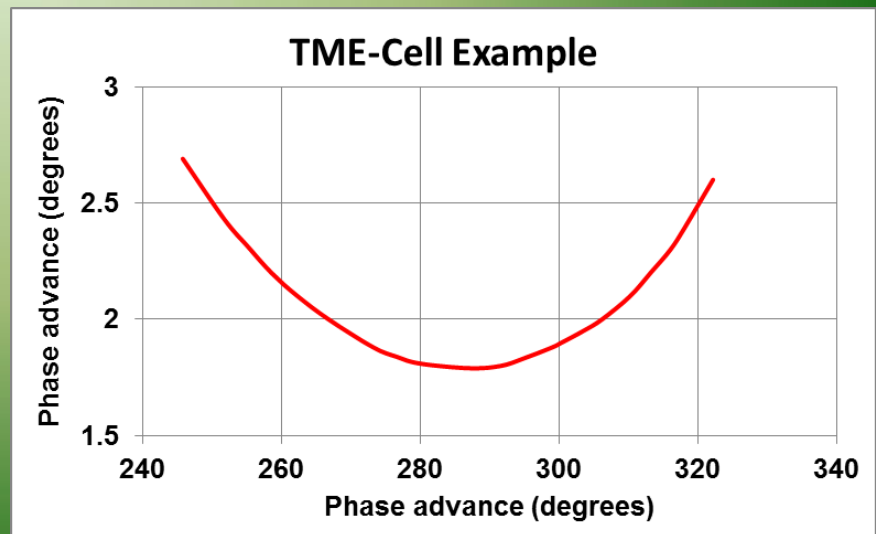
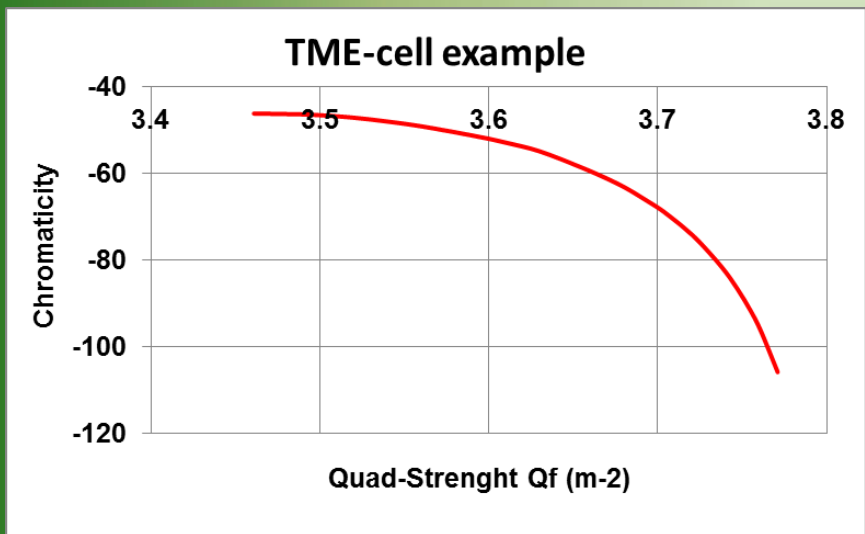
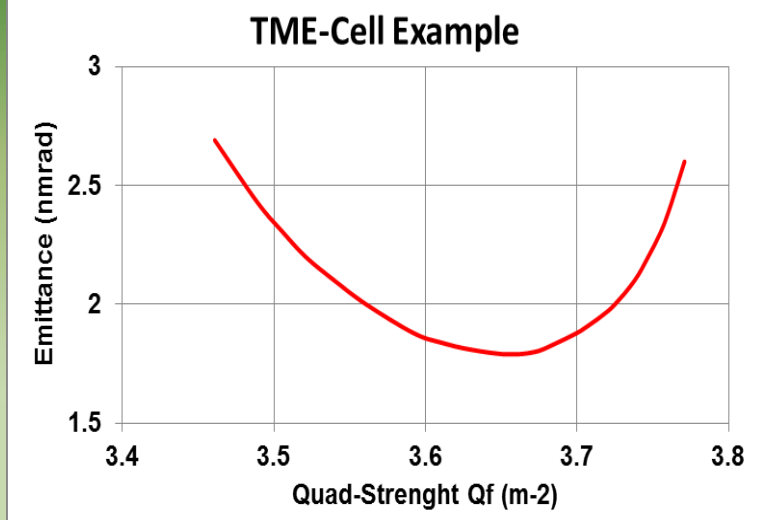
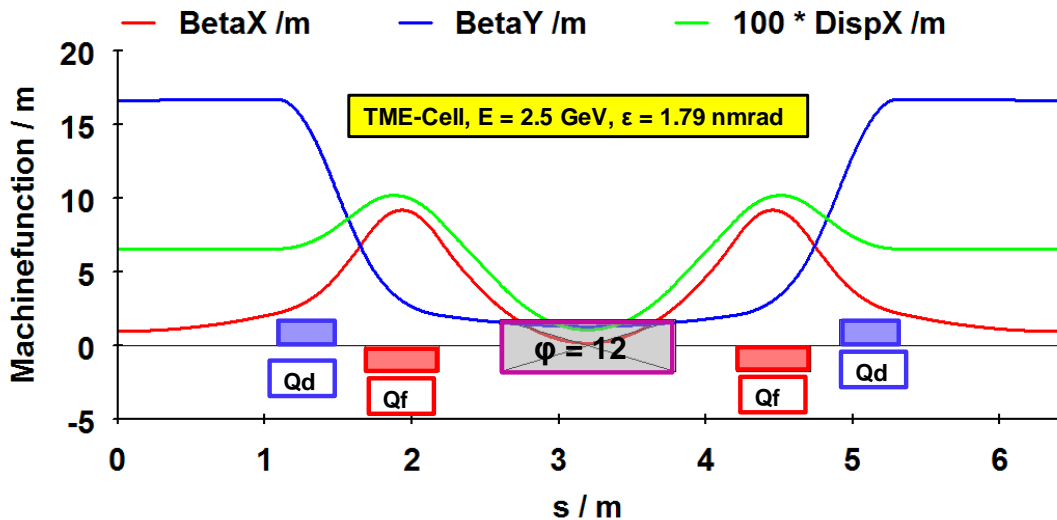

Longitudinal Bending Gradient

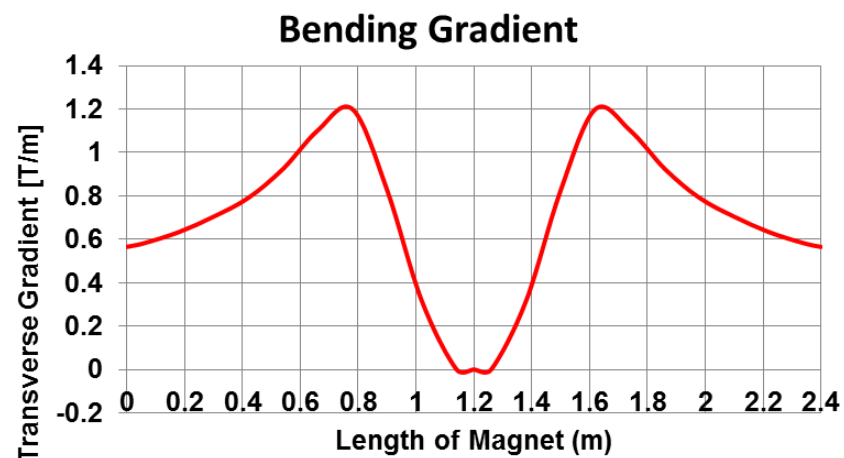
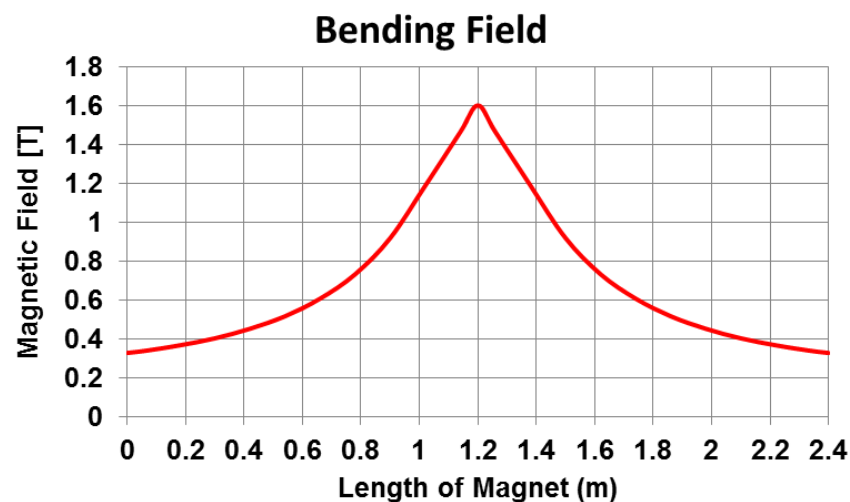
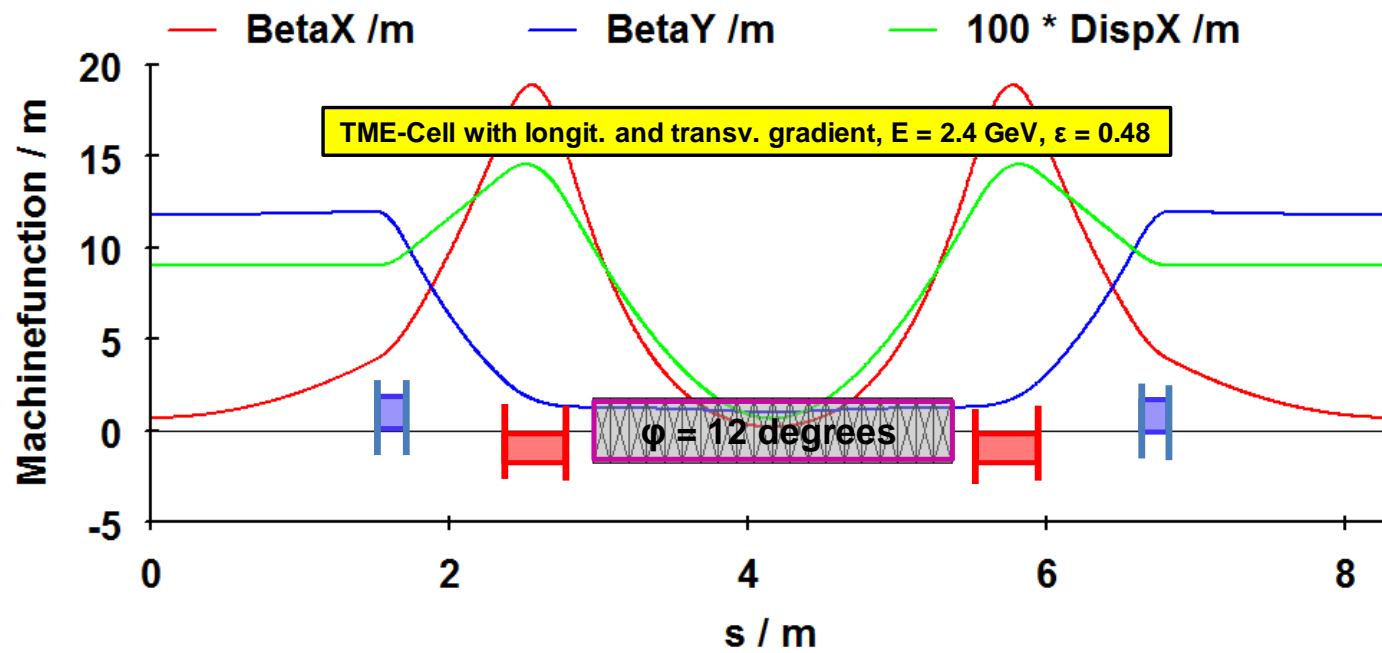

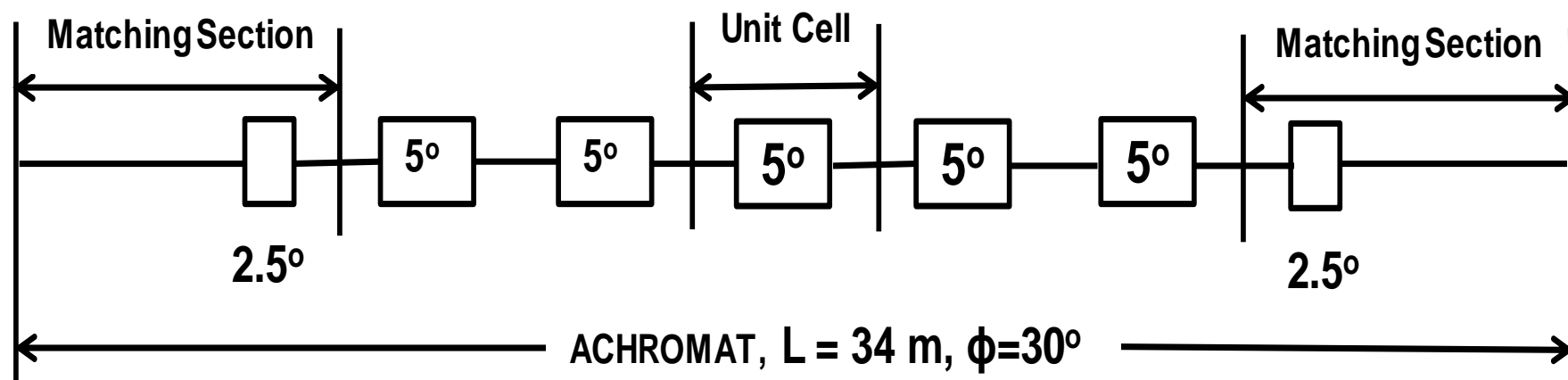

The layout for the diffraction limited light source utilizing the MBA structure. The bending magnets in the unit cell with a deflection of 5 degrees and the matching section with an angle of 2.5 degrees. The lattices got the acronym DIFL



Unit Cell of DIFL-Lattice

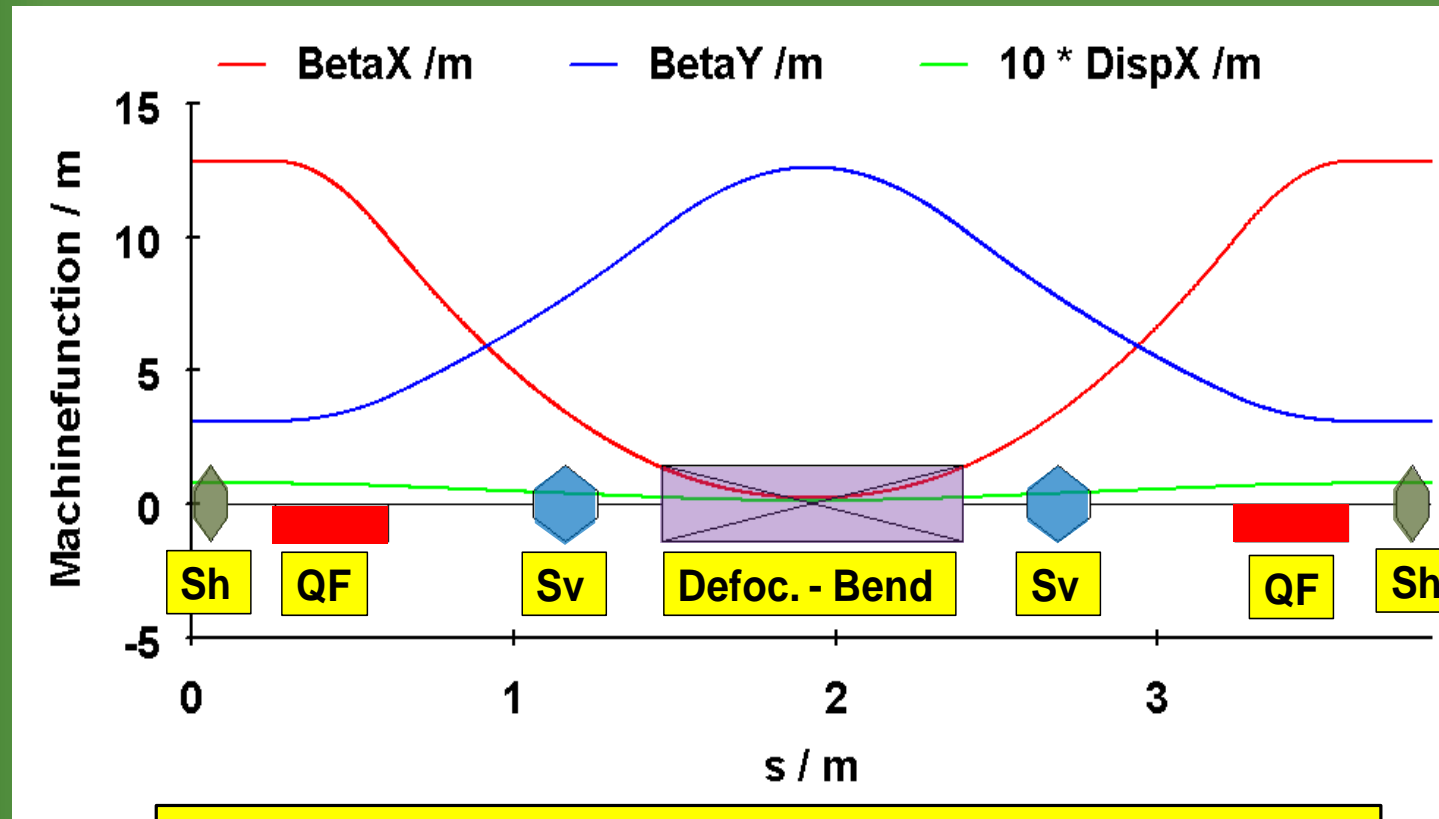

TME Structure, $E = 3.0 \text{ GeV}$, $\epsilon = 0.5 \text{ nmrad}$, $\varphi = 5 \text{ degr.}$

The arrangements of the magnets within a unit cell of the multi bend Achromat and the corresponding machine functions. The parameters of the magnets are: Bending: $L=0.931482 \text{ m}$, $\rho=10.674 \text{ m}$, $B = 0.93749 \text{ T}$, $k=-0.900 \text{ m}^{-2}$; QF: $L = 0.35 \text{ m}$, $k=1.992 \text{ m}^{-2}$, $g=19.92 \text{ T/m}$, $g^*L = 6.972 \text{ T}$; Sh: $L= 0.1 \text{ m}$, $m=53.347\text{m}^{-3}$, $\Sigma\text{Sh}^*L=5.335 \text{ m}^{-2}$; Sv: $L=0.2 \text{ m}$, $m = -42.730 \text{ m}^{-3}$, $\Sigma\text{Sv}^*L=8.546 \text{ m}^{-2}$

Characteristics of Unit Cell

Emittance of the DIFL-Unit-Cell

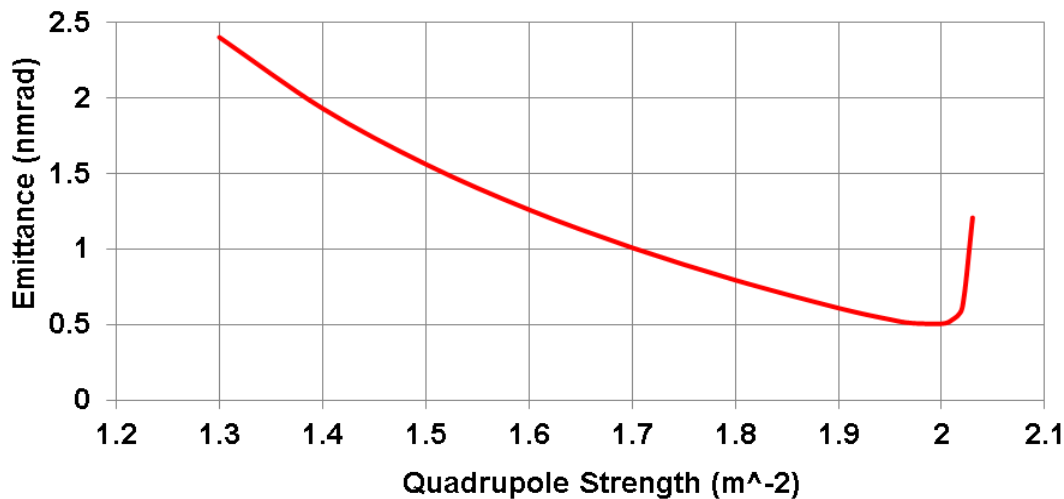

Emittance of the unit cell as a function of the strength of the focusing quadrupole.

Horizontal chromaticity of the unit cell of the lattice DIFL

Horiz. Chrom. of the DIFL-Unit-Cell

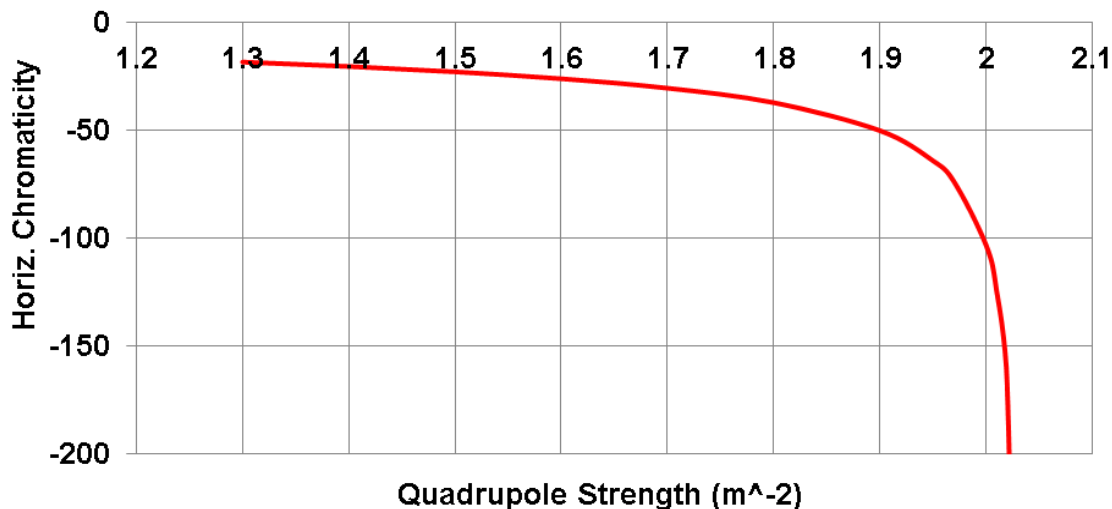

Characteristics of Unit Cell

Dynamic Aperture of DIFL - Unit Cell

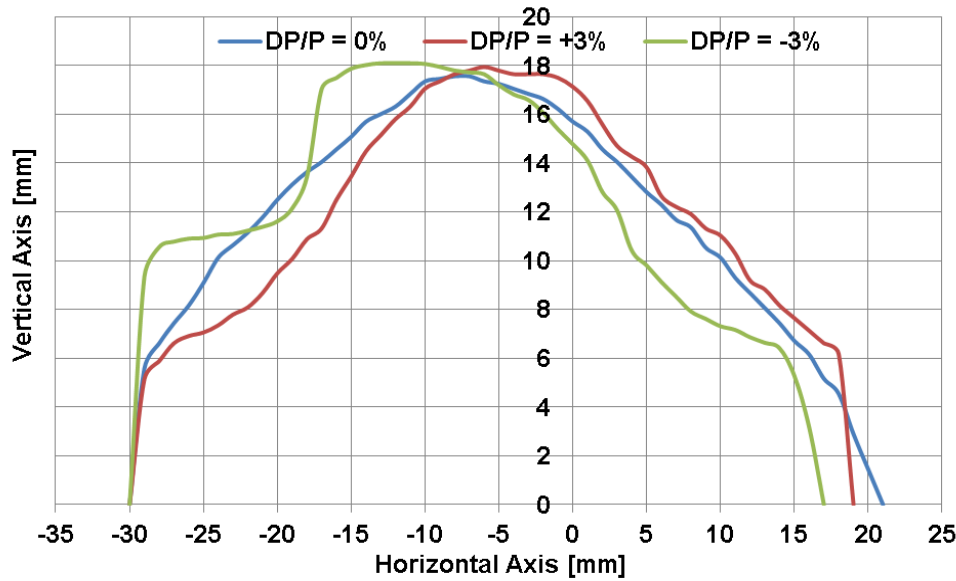

Dynamic aperture of the unit cell for the energy deviations of $\Delta p/p = -3\%$ (green line), $\Delta p/p = 0\%$ (blue line), $\Delta p/p = 3\%$ (red line).

Tune Diagram

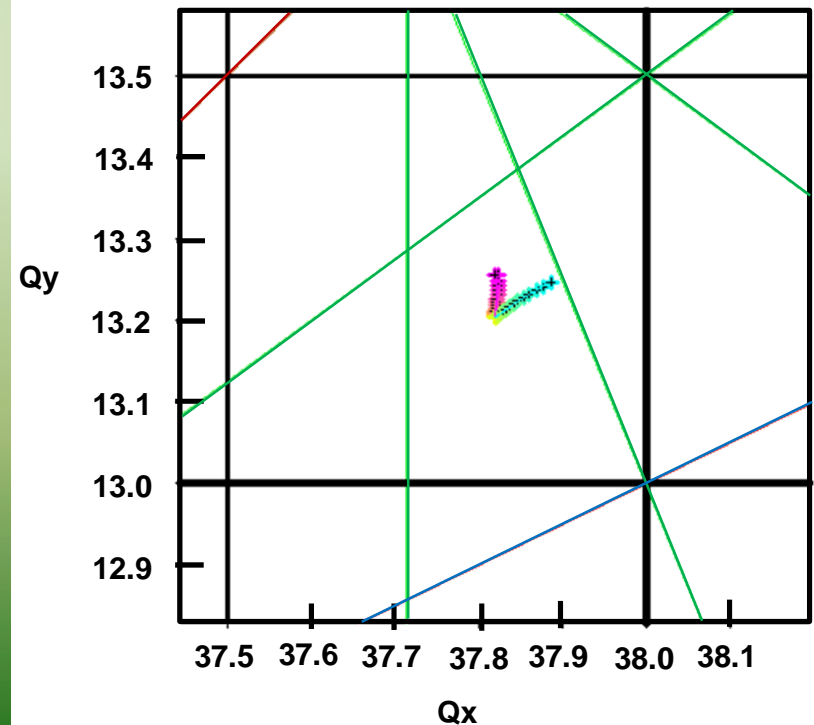

Lattice of DIFL (7BA)

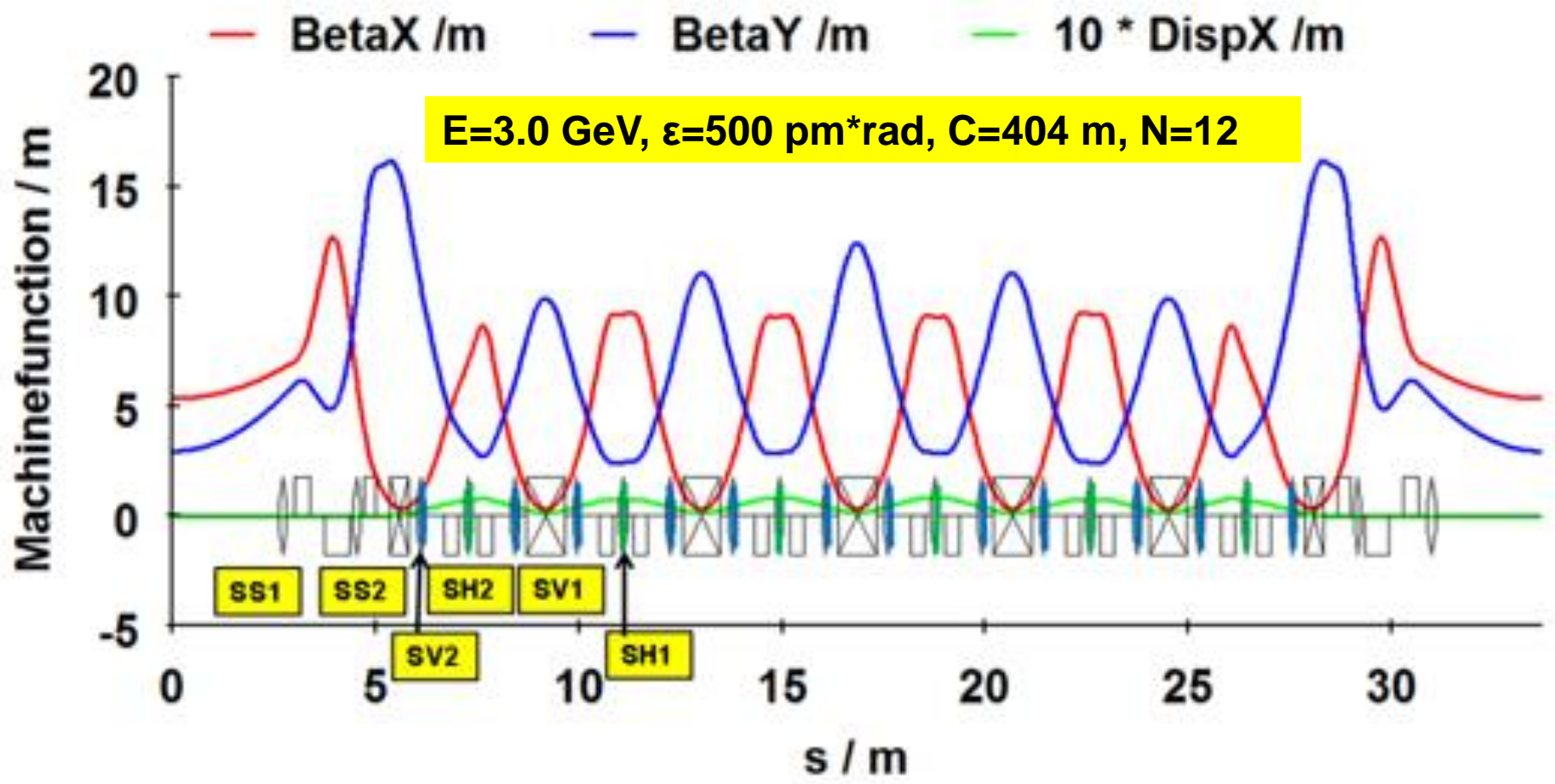

Machine function of the chosen lattice DIFL for the proposed diffraction limited light source

Characteristics of DIFL

Dynamic Aperture of DIFL

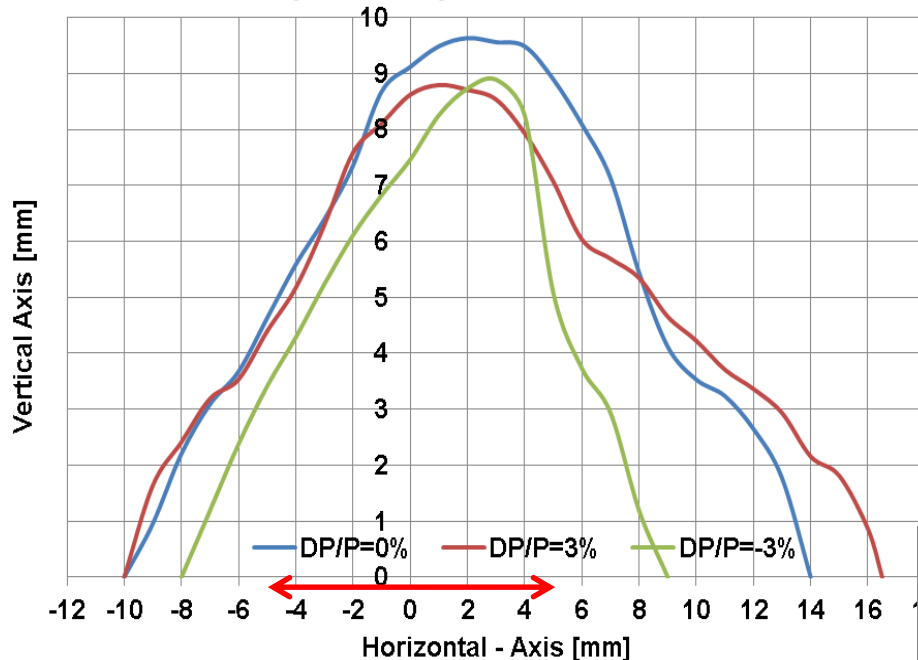

Dynamic aperture of lattice DIFL for the energy deviations of $\Delta p/p = -3\%$ (red line), $\Delta p/p = 0\%$ (black line), $\Delta p/p = 3\%$ (blue line).

$$X(s) = 2 * 1.33 * \eta(s) * (\Delta E/E)$$

$$A(s) = (X(s)^2) / \beta(s), (\Delta E/E) = 3\%$$

$$A = 5 \text{ mm} * \text{mrad}, \beta(s=0) = 5.2 \text{ m/rad} \\ \Rightarrow E(0) = \pm 5.2 \text{ mm}$$

Machine Aperture

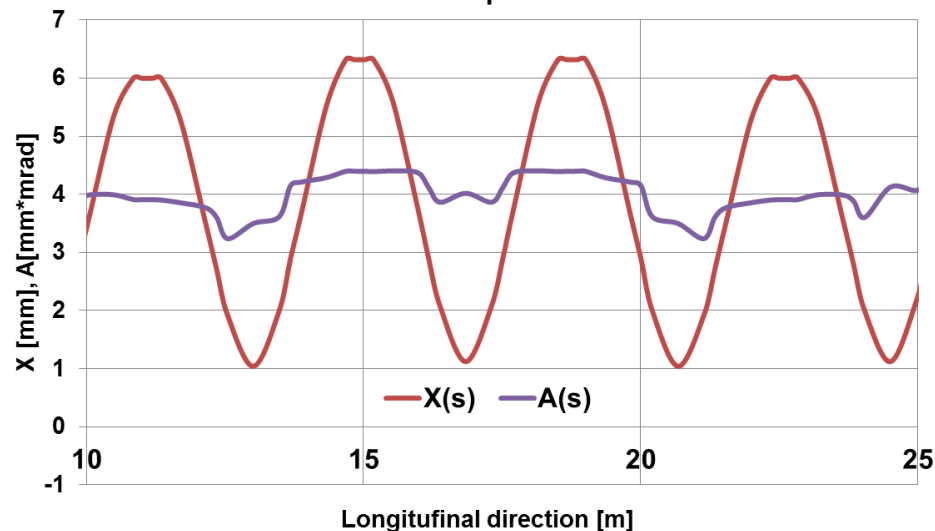



Summary (1995)

1995: According to this investigation it should be possible to build Synchrotron Light Sources with an reduction of the emittance by a factor of 10 in comparison to the existing machines.



First proposal of MAX IV (2003)

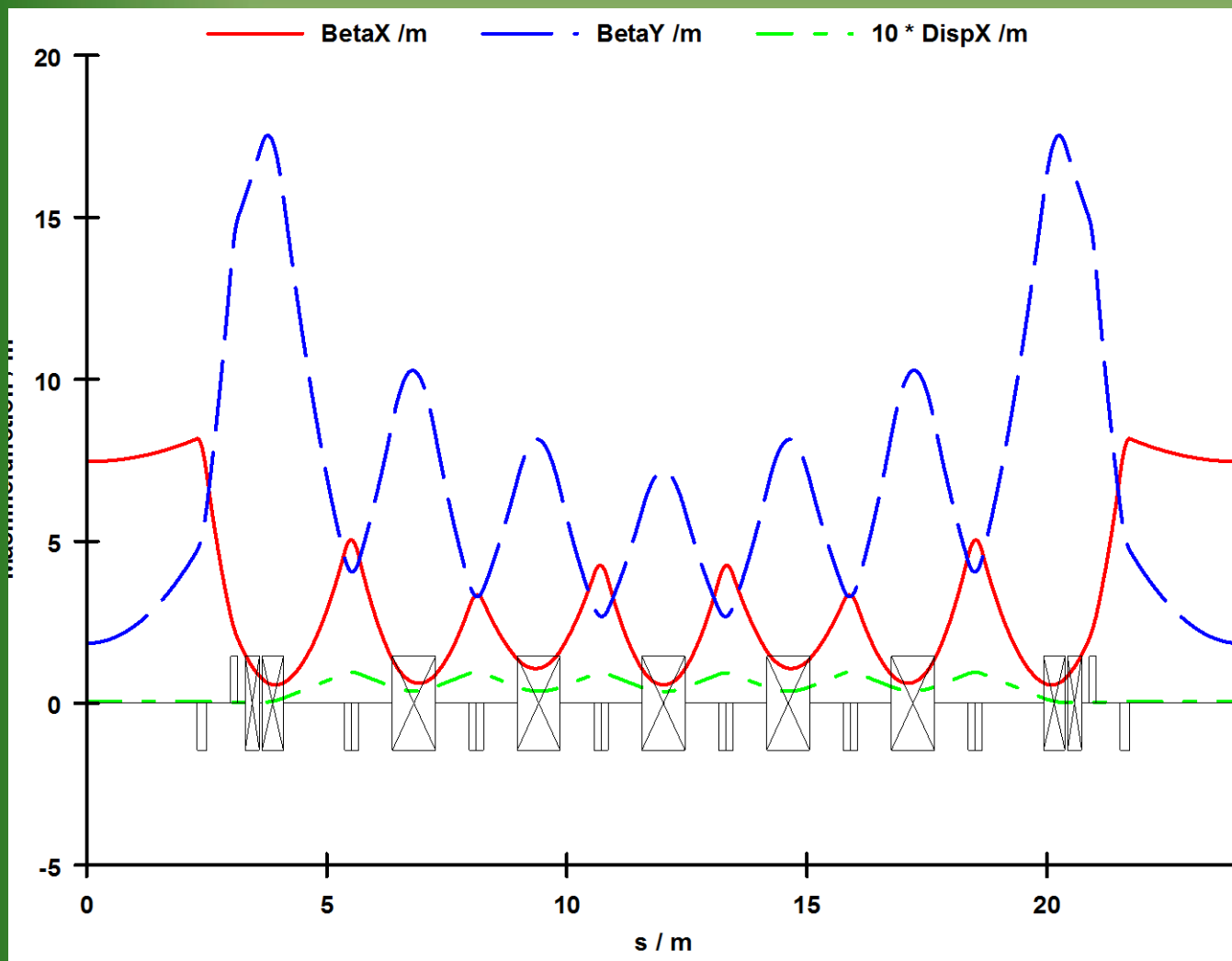

Parameters:

$E = 3.0 \text{ GeV}$

$C = 287.2 \text{ m}$

$N = 12 \text{ fold}$

$\varphi = 4.67 \text{ degr.}$

$\epsilon_x = 1.2 \text{ nmrad}$

$l = 4.6 \text{ m}$

$\beta_x = 7.6 \text{ m/rad}$

$\beta_y = 1.7 \text{ m/rad}$

Layout of MAX IV (2014)

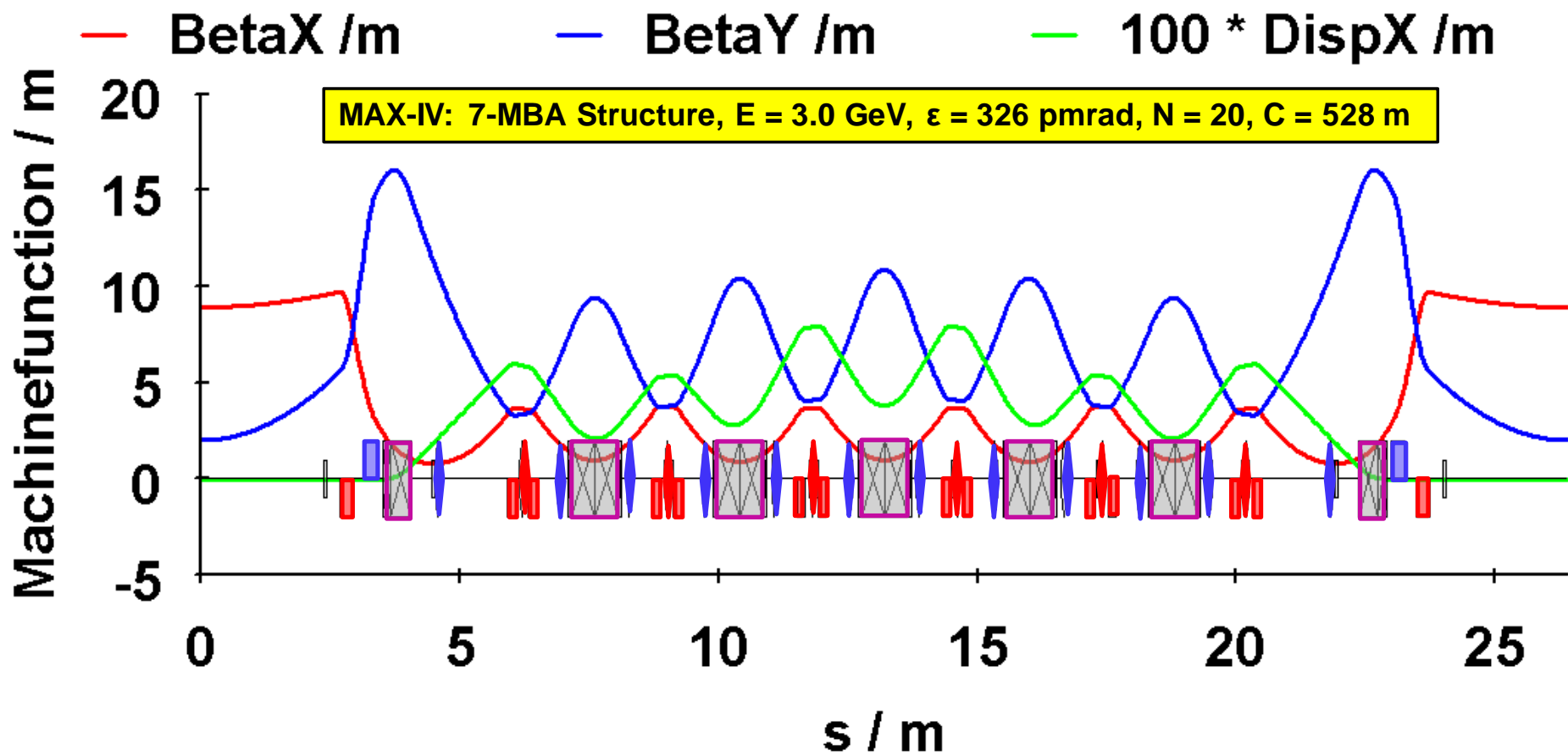



Layout of MAX IV (2014)

Emittance of MAX-IV Unit Cell

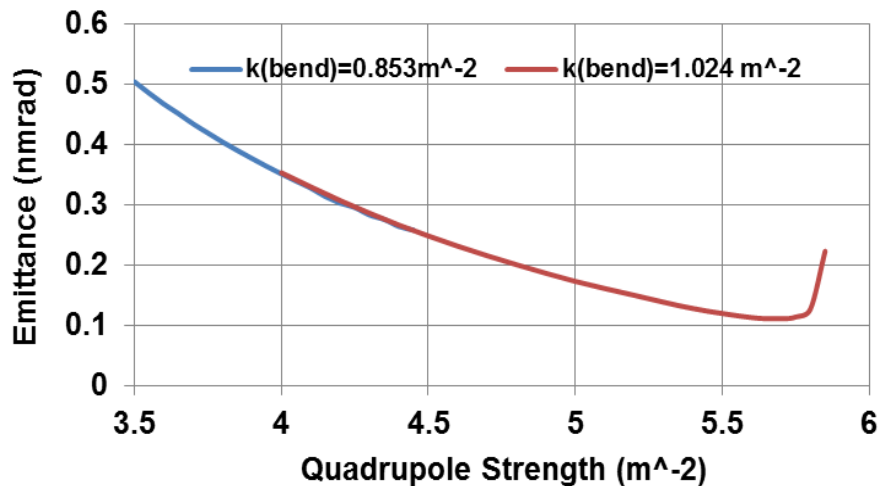

Vert. Chrom. of MAX-IV Unit Cell

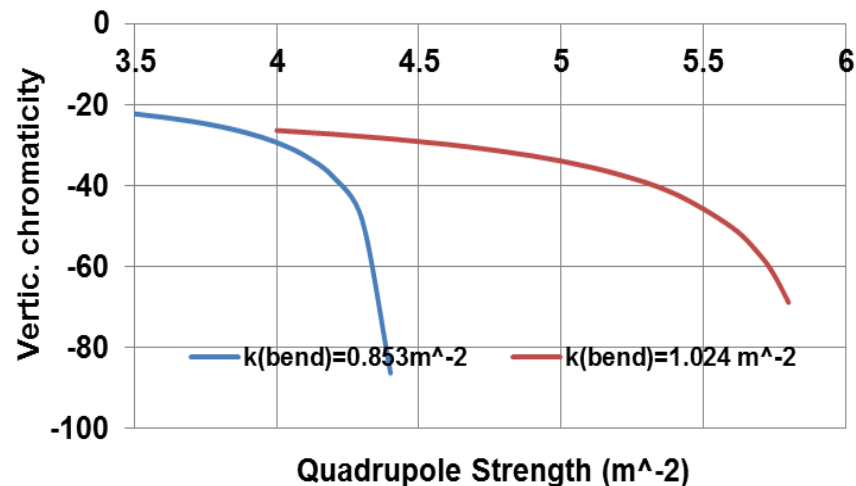

Horiz. Chrom. of MAX-IV Unit Cell

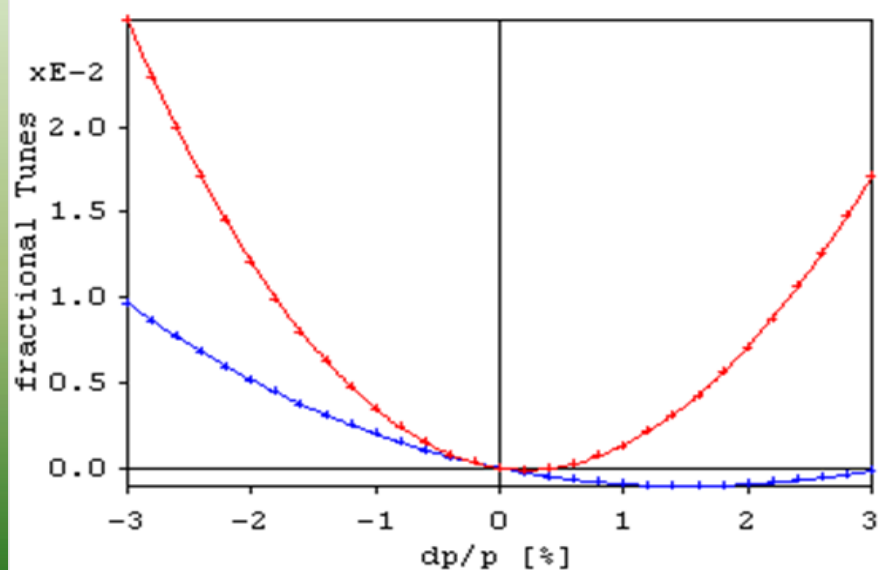
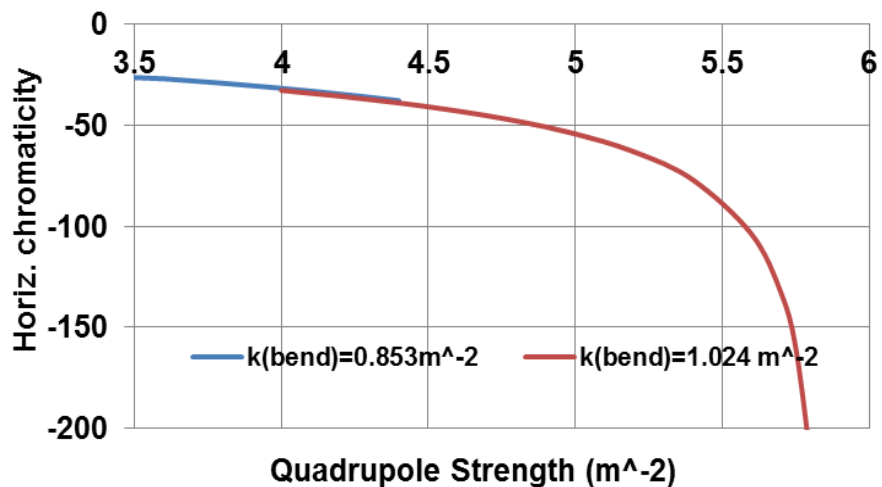

Layout of SIRIUS (Brazil)

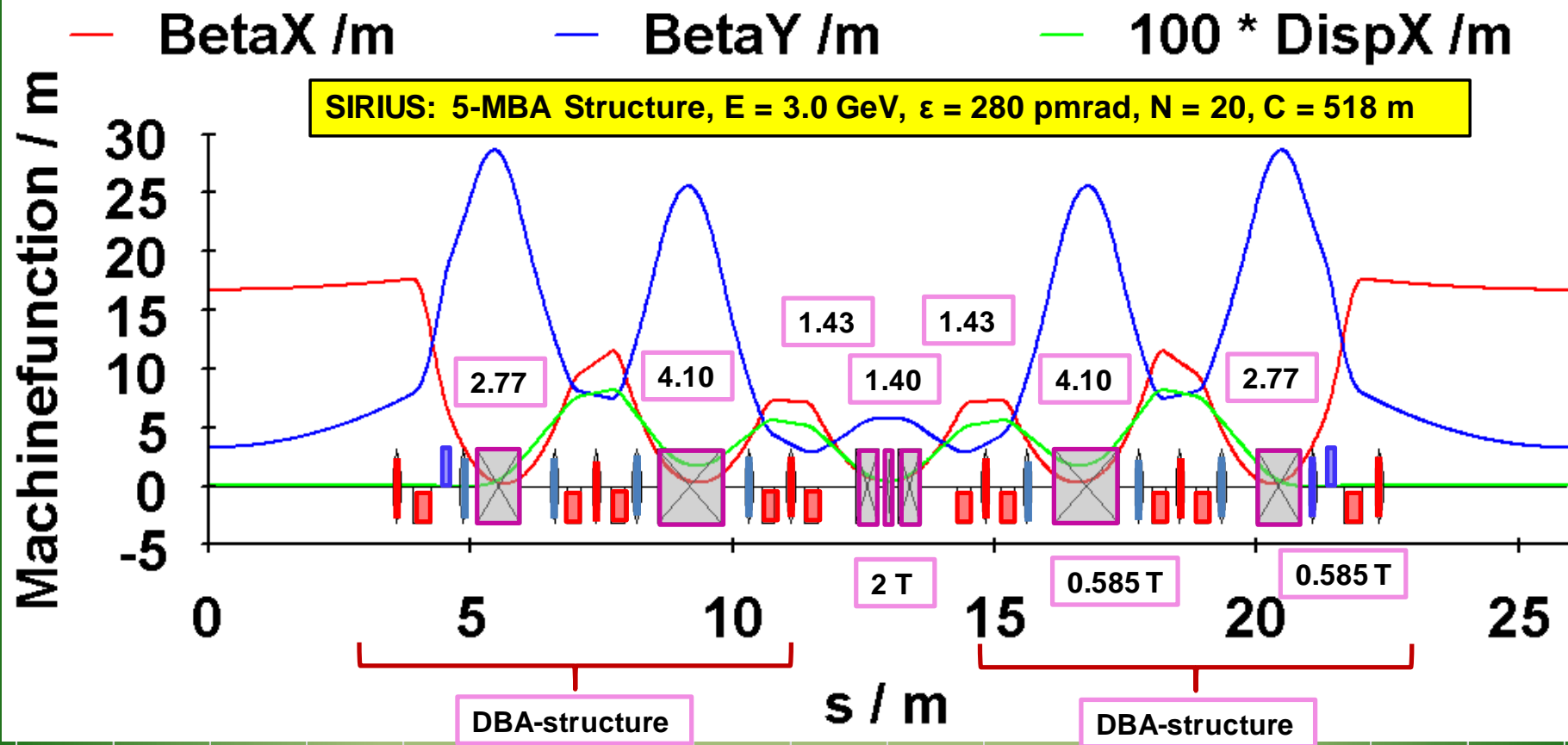

Machine functions within one Achromat of the 5 MBA –lattice proposed by L. Liu et. al. (2013) for the Brazilian light source SIRIUS. The bending magnets are presented by blue boxes.



Comparison 7MBA and 5MBA

The emittance with the high field bending in the middle of the magnet is: $\epsilon = 0.28$ nmrad.

The emittance without the high field bending in the middle of the magnet is: $\epsilon = 0.31$ nmrad.

Hence the emittance is decreased by roughly 10 %

The emittance for the 7MBA is: $\epsilon = 0.326$ nmrad and the emittance for the 5MBA is: $\epsilon = 0.280$ nmrad . This is a ratio of: $(7MBA/5MBA)=1.164$.

According to the number of the bendings the ratio should be: $(5 / 7)^3 = 0.364$, hence there is a factor of 3.2 between the ratios.

This we have to understand!

Comparison 7MBA and 5MBA

MAX IV: 7MBA, N=20, Jx = 1.841								
1.)= $H/\rho^3 =$	2.79	9.09	15.3	21.4	15.3	9.09	2.79	$\cdot 10^{-8}$
2.)= $1/\rho^2 =$	1.37	2.74	2.74	2.74	2.74	2.74	1.37	$\cdot 10^{-3}$
1.) / 2.) =	2.04	3.32	5.58	7.81	5.58	3.32	2.04	$\cdot 10^{-5}$
Sum =	2.908		10.303			2.908		$\cdot 10^{-5}$
								16.12 $\cdot 10^{-5}$
SIRIUS: 5MBA, N=20, Jx = 1.318								
1.)= $H/\rho^3 =$	6.14	18.77	2.56	5.19	2.56	18.77	6.14	$\cdot 10^{-8}$
2.)= $1/\rho^2 =$	2.82	4.18	1.46	4.76	1.46	4.18	2.82	$\cdot 10^{-3}$
1.) / 2.) =	2.18	4.49	1.75	1.09	1.75	4.49	2.18	$\cdot 10^{-5}$
Sum =	5.053		3.483			5.053		$\cdot 10^{-5}$
								13.59 $\cdot 10^{-5}$

The main reason is that the bending in the middle of the 5MBA-structure has a factor of 3 smaller contribution as the 3 bendings in the middle of the 7 MBA

Layout of ESRF-II (HMBA)

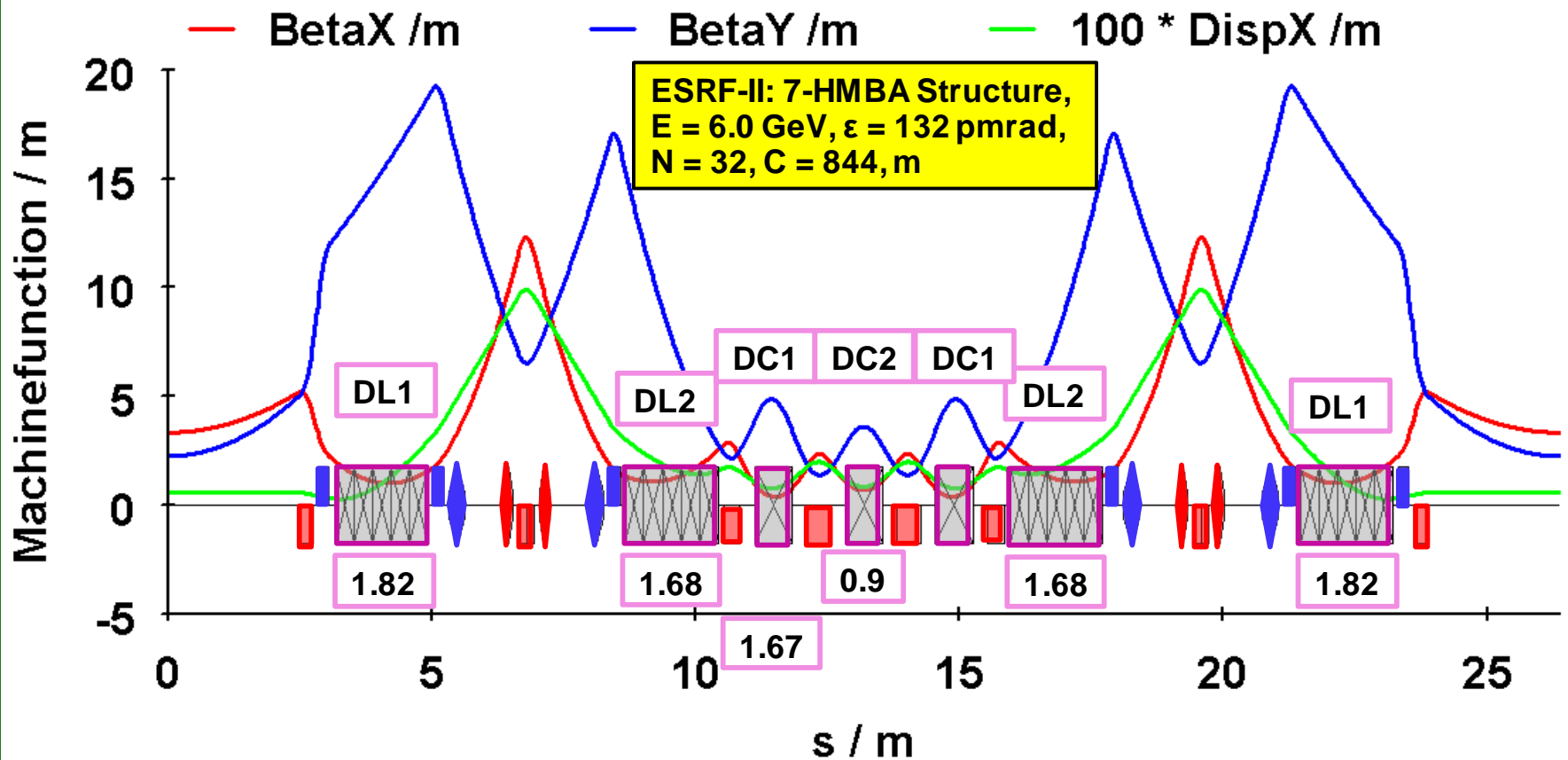

Machine functions within one achromat of the 7 HMBA –lattice. 1.)The achromat has at the beginning and end a DBA structure and the DBA-structures are combined with combined bendings. 2.)The long bendings have a longitudinal gradient. 3.)The phase advance between the sextupole is $\approx n \cdot \pi$.

Upgrade of APS: APS II (HMBA)

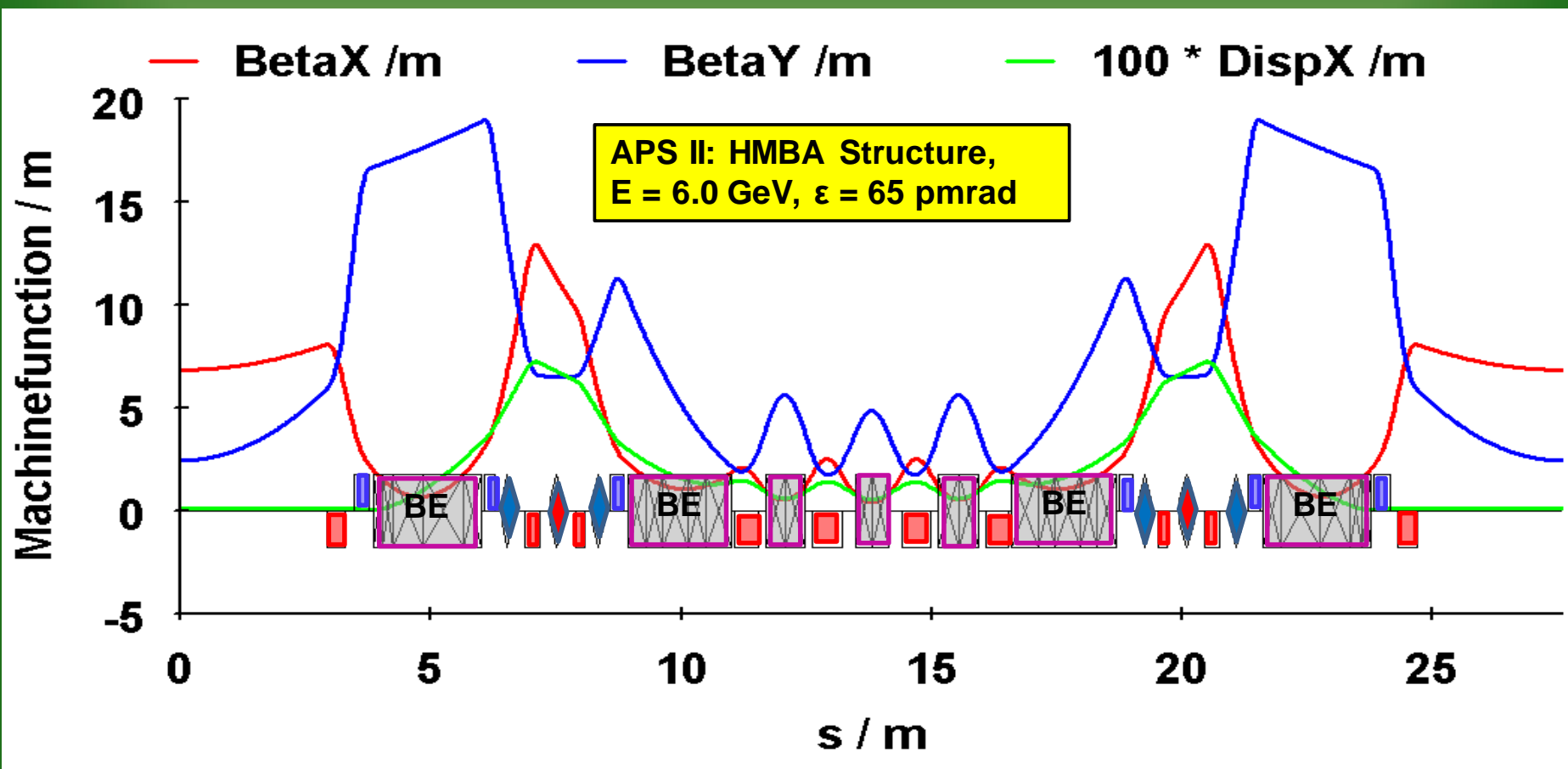

The people at APS made a comparison between the MAX IV lattice (7MBA) and the lattice of the ESRF (HMBA) and found that the HMBA has some advantages (the sextupole settings are smaller).



Longitudinal Field (HMBA)

Longitudinal Bending Field (ESRF II)

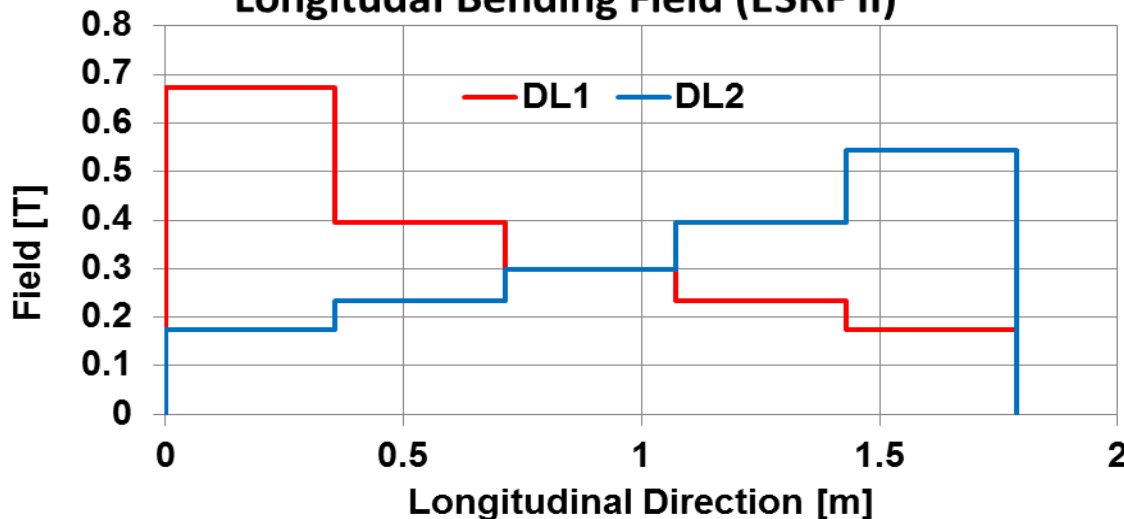

Change of the emittance for ESRF II with the longitudinal gradient:
with gradient $\epsilon = 0.132$ nrad,
without gradient $\epsilon = 2.41$ nrad,
with inverse gradient $\epsilon = 6.67$ nrad.

Longitudinal Bending Field (APS II)

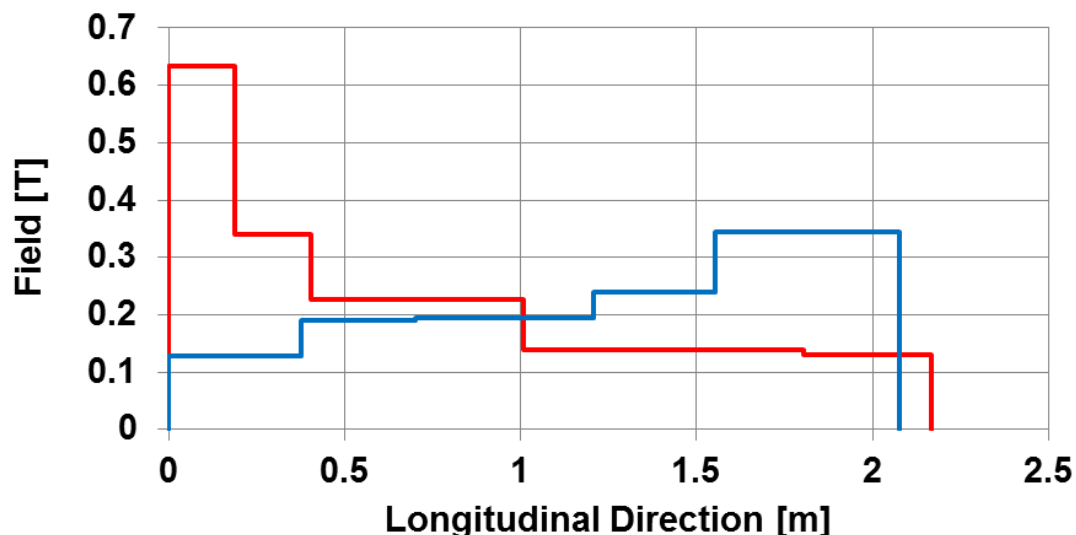

Upgrade of DIAMOND (DDBA)

Diamond II: DDBA Structure, $E = 3.0$ GeV, $\epsilon = 280$ pmrad, $N = 24$, $C = 543$ m

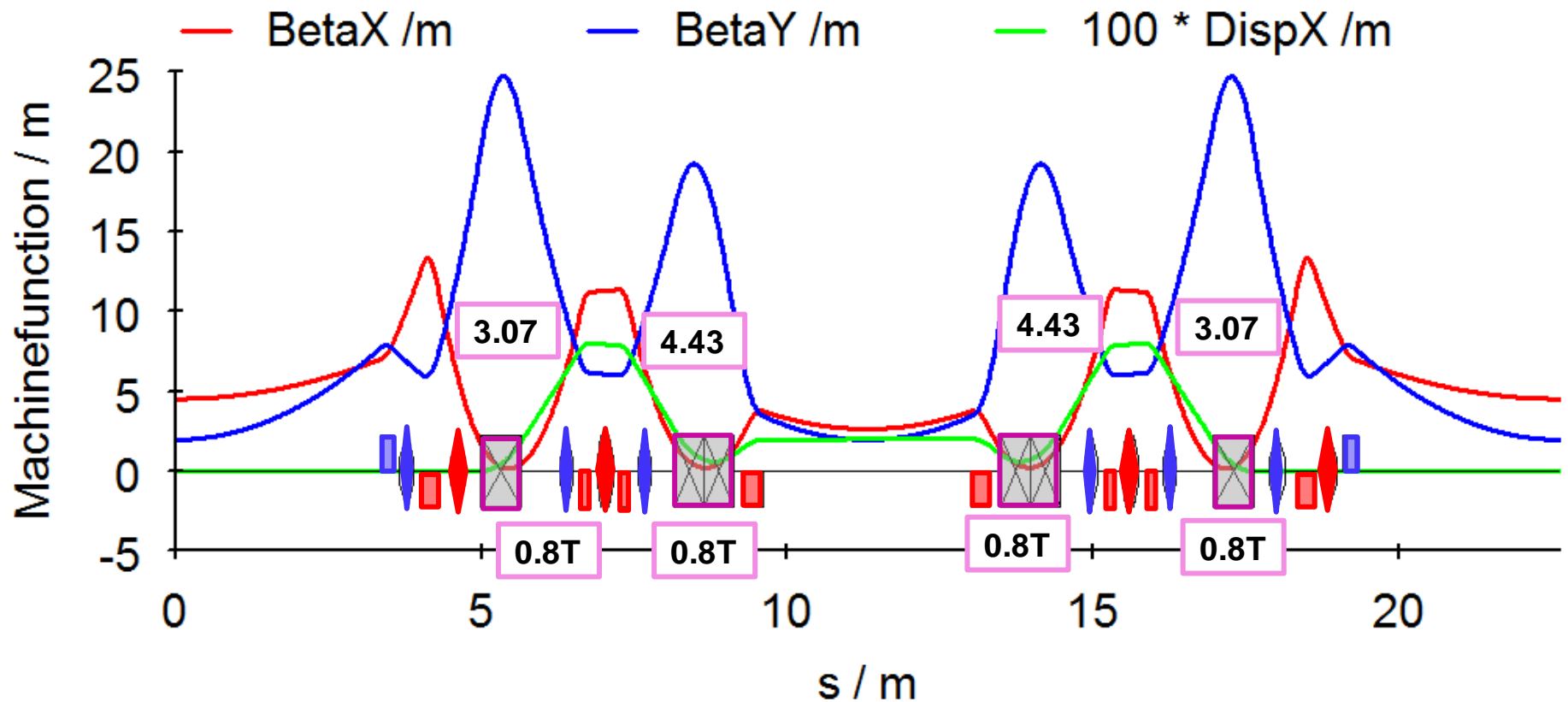

Upgrade of ANKA (DDBA)

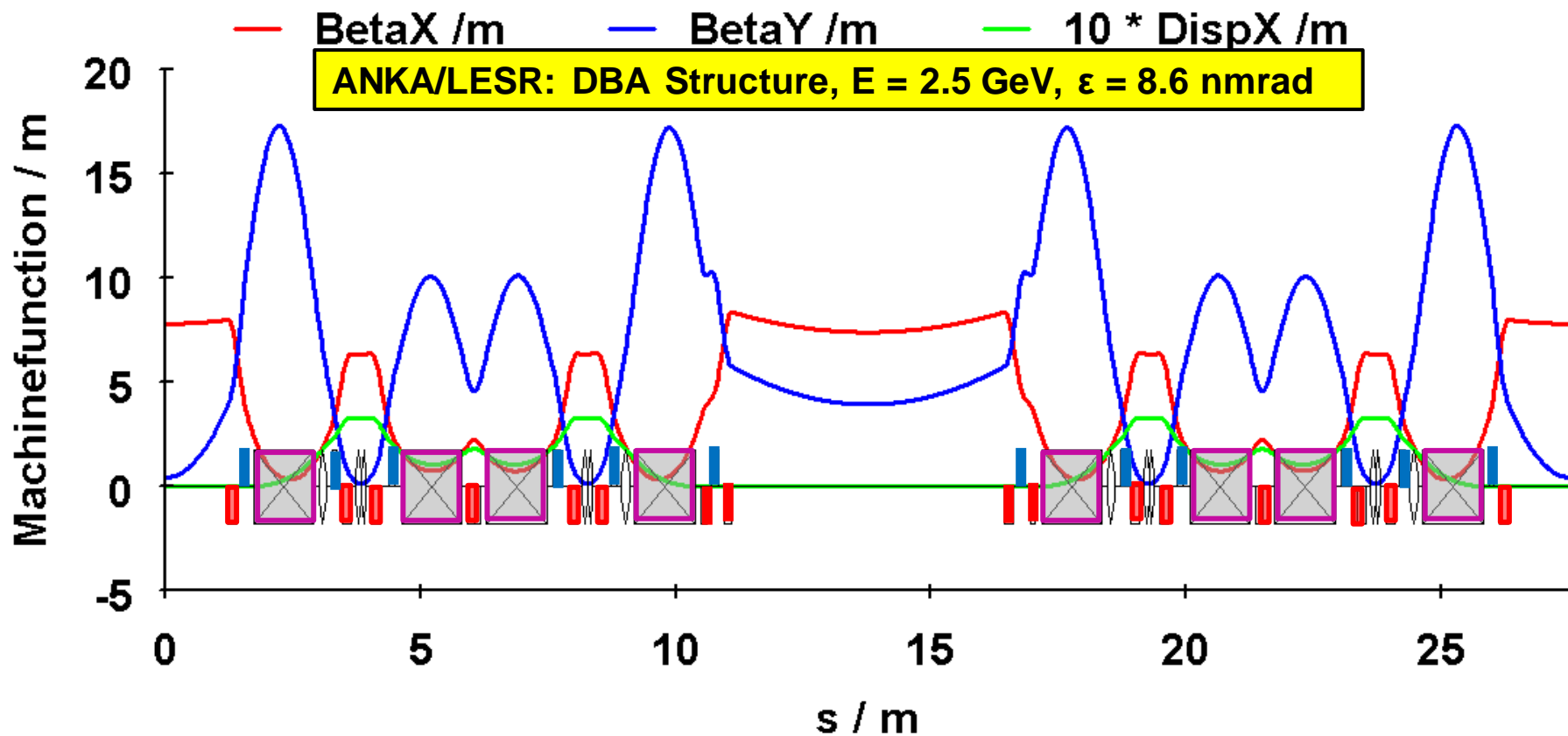

**This proposal has been made by BINP
(E.Levichev and his co-workers)**

Upgrade of ALS (9HMBA)

TBA

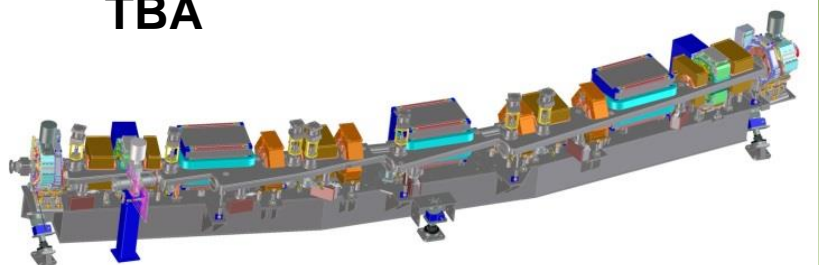

9BA

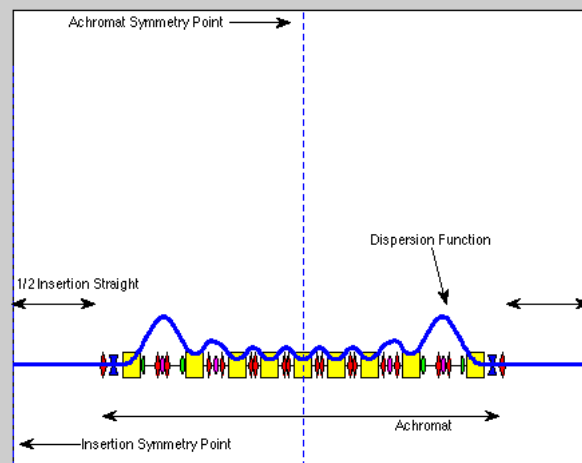
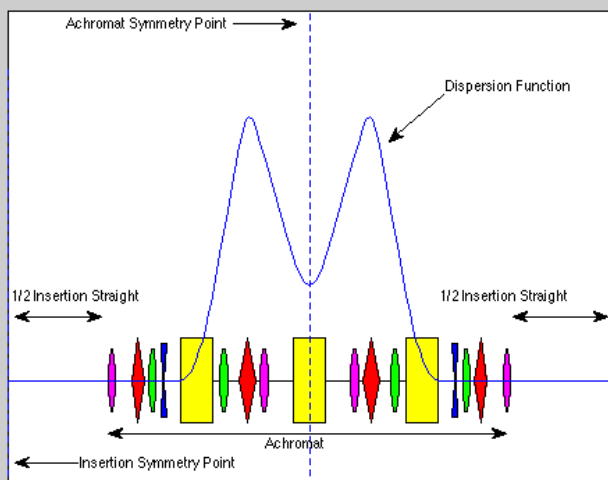
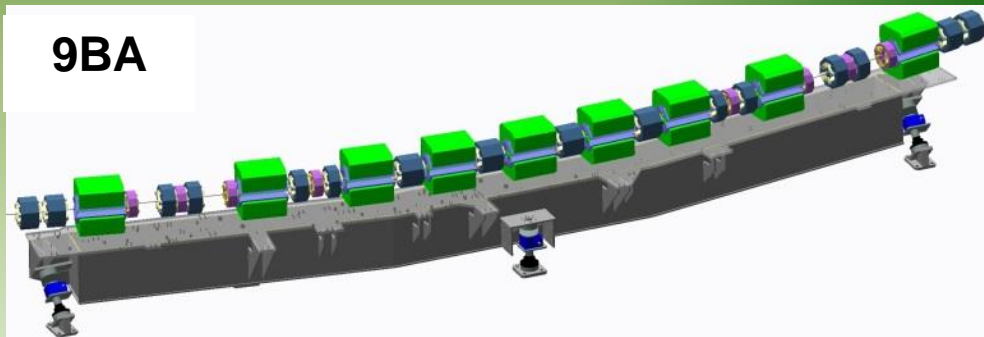

$$e_x = 2000 \text{ pm} @ 1.9 \text{ GeV}$$

$$e_x = 52 \text{ pm} @ 2.0 \text{ GeV}$$

Upgrade of Elettra

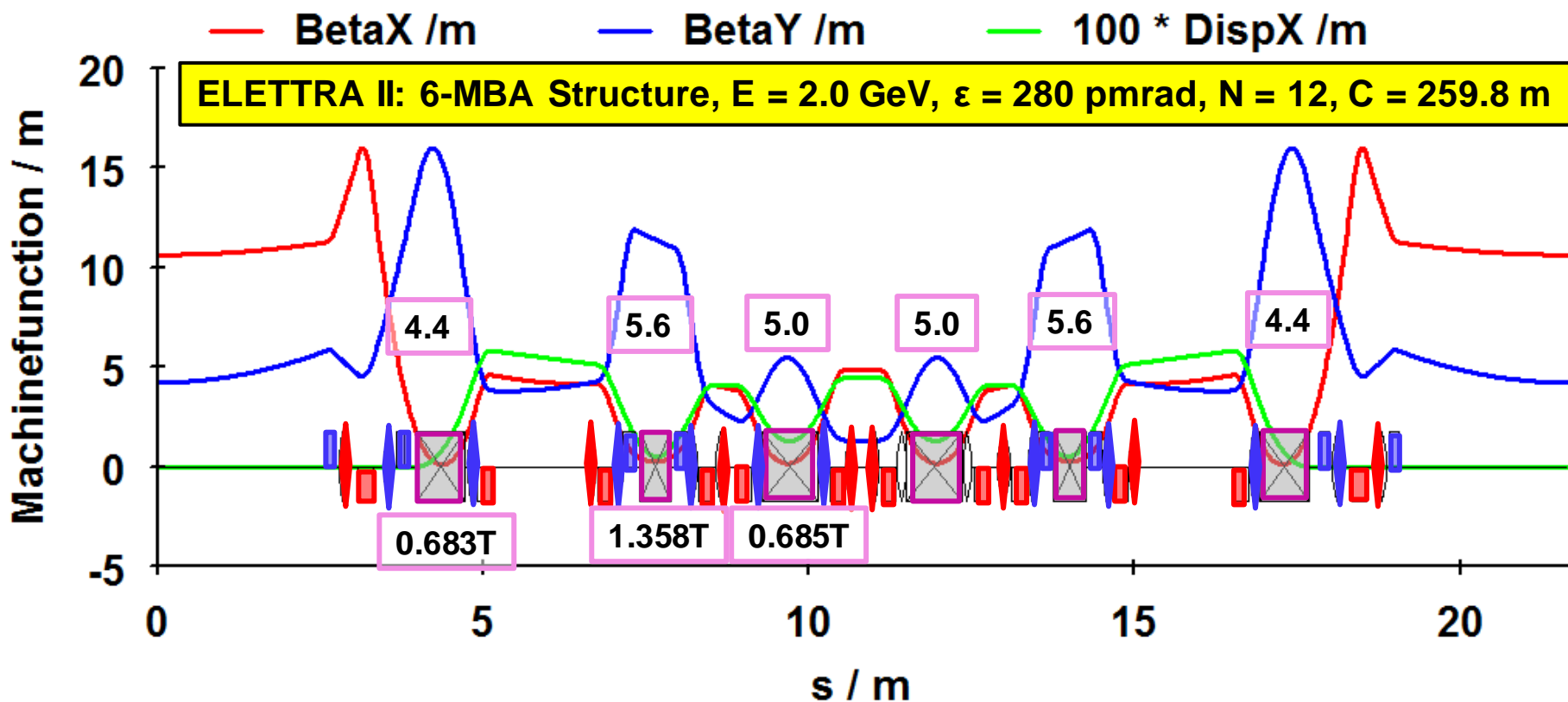



Upgrade of SLS (Unit Cell)

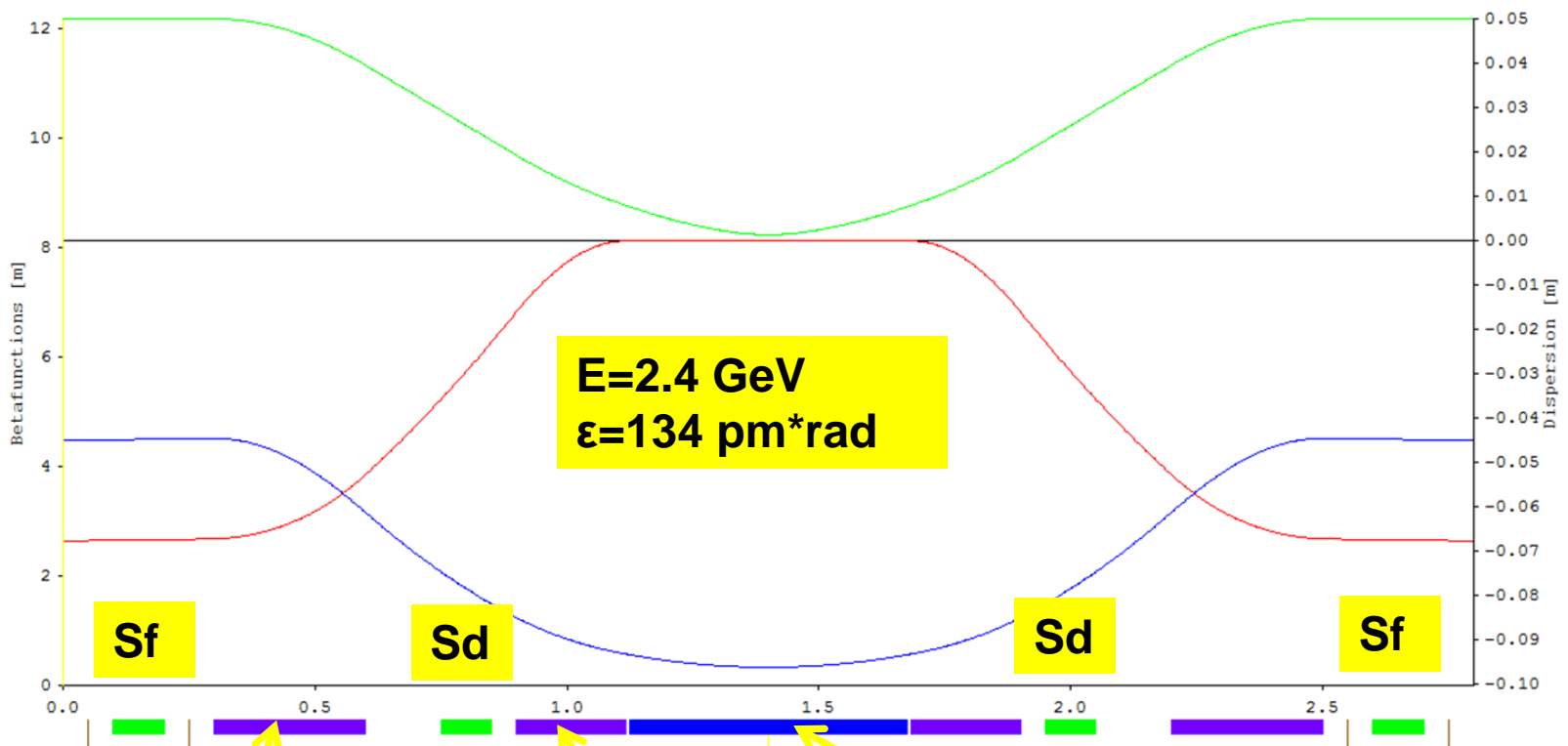

B=-0.3633 T
k= 3.87 m⁻²
Φ=-0.78 degr.

B=0.70636 T
k= -3.6441 m⁻²
Φ=1.09 degr.

There are 5 bendings in a unit cell

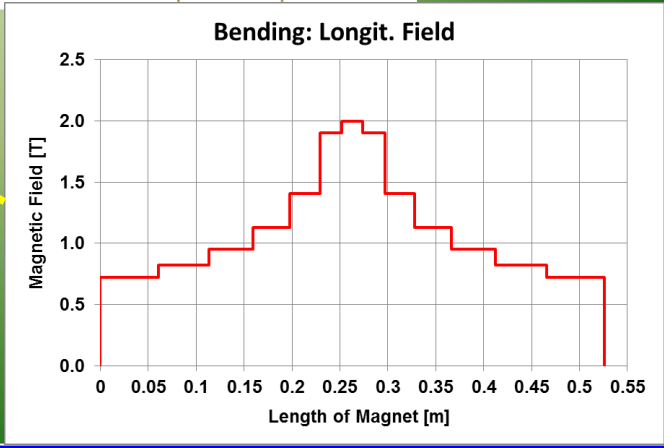



Achromat of SLS- II

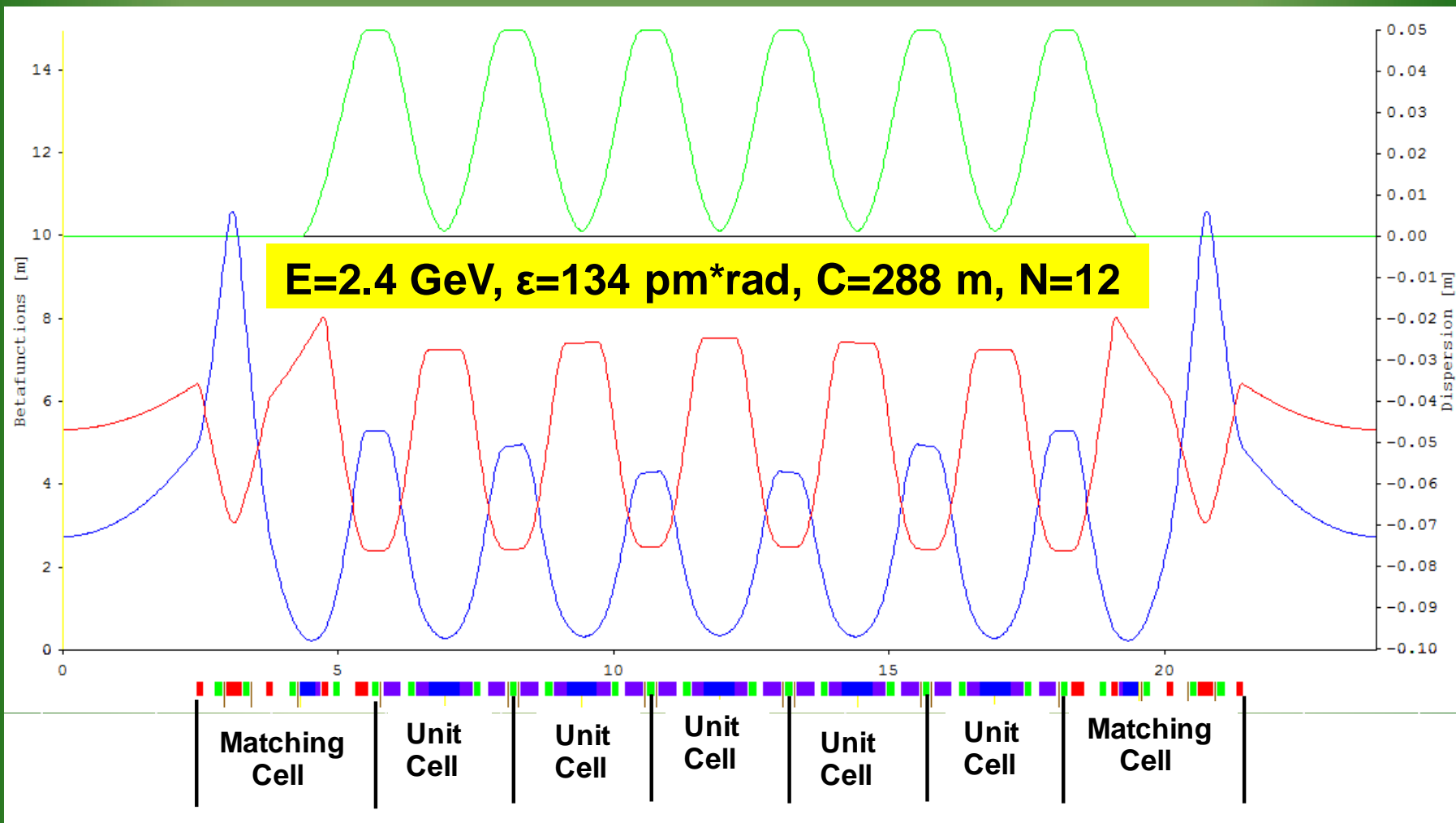



Summary

Source	DIFL	MAX IV	SIRIUS	ESRF II	APS II	DIAM. II	ALS II	ELET. II	SLS II
Energy [GeV]	3	3	3	6	6	3	2	2	2.4
Circumf. [m]	404	528	518.4	844	1104	543	196.8	260.0	288.0
Emitt. [nmrad]	0.49	0.33	0.28	0.133	0.065	0.28	0.052	0.280	0.132
Jx	1.29	1.8	1.31	1.51	1.62	1.32	1.300	1.260	1.690
Nb - Cells	12	20	20	32	40	24	12	12	12
Nb-Be-per Cell	7	7	5	7	7	4	9	6	6
L-Straights [m]	5.2	4.728	7.02	5.4	5.82	10.1	6.760	5.200	4.570
Radius (B) [m]	10.674	19.104	17.15	26	33	12.508		4.900	4.000
Field (Be) [T]	0.9375	0.5238	0.5835	0.7698	0.6065	0.8000		1.3615	2.0014
k (Be) [m^-2]	0.916	0.856	0.78	1.85	2.34	1.44		2.200	3.870
Grad. (Be) [T/m]	9.166	8.566	7.805	37.025	46.832	14.410		14.677	30.981
k (Qu) [m^-2]	2.0	4.1	3.3	4.6	4.0	5.3	20.0	8.0	8.5
Grad. (Qu) [T/m]	20.0	40.5	33.0	91.1	80.3	53.0	133.4	53.2	68.0
Tune QX	38.20	42.24	44.60	76.48	95.11	51.60		33.19	38.10
Tune Qy	13.24	16.27	12.4	25.5	36.15	18.46		9.330	10.220
Chorm-Y	-79.4	-50	-113.3	-97.12		-129		-79.500	-69.500
Chrom.-Y	-38.5	-50.2	-80.2	-84.13	0.3927	-94.41		-47.310	-34.160
Aver.-Phi[rad]	0.0748	0.0449	0.0628	0.0281	0.0224	0.0655	0.0582	0.0873	0.0873
Factor F	168	730	164	253	259	146	86	133	58
Perc. [%]	15.4	17.9	27.1	20.5	21.1	44.6	41.2	24.0	19.0
Norm.-Emitt.	32.3	100.6	31.1	41.5	39.6	27.5	16.4	26.1	8.6

$$\text{Norm.-Emittance} = 0.001 * \text{Emitt.} * (\text{Nb}^3) / (\text{E}^2)$$



Thank you very much

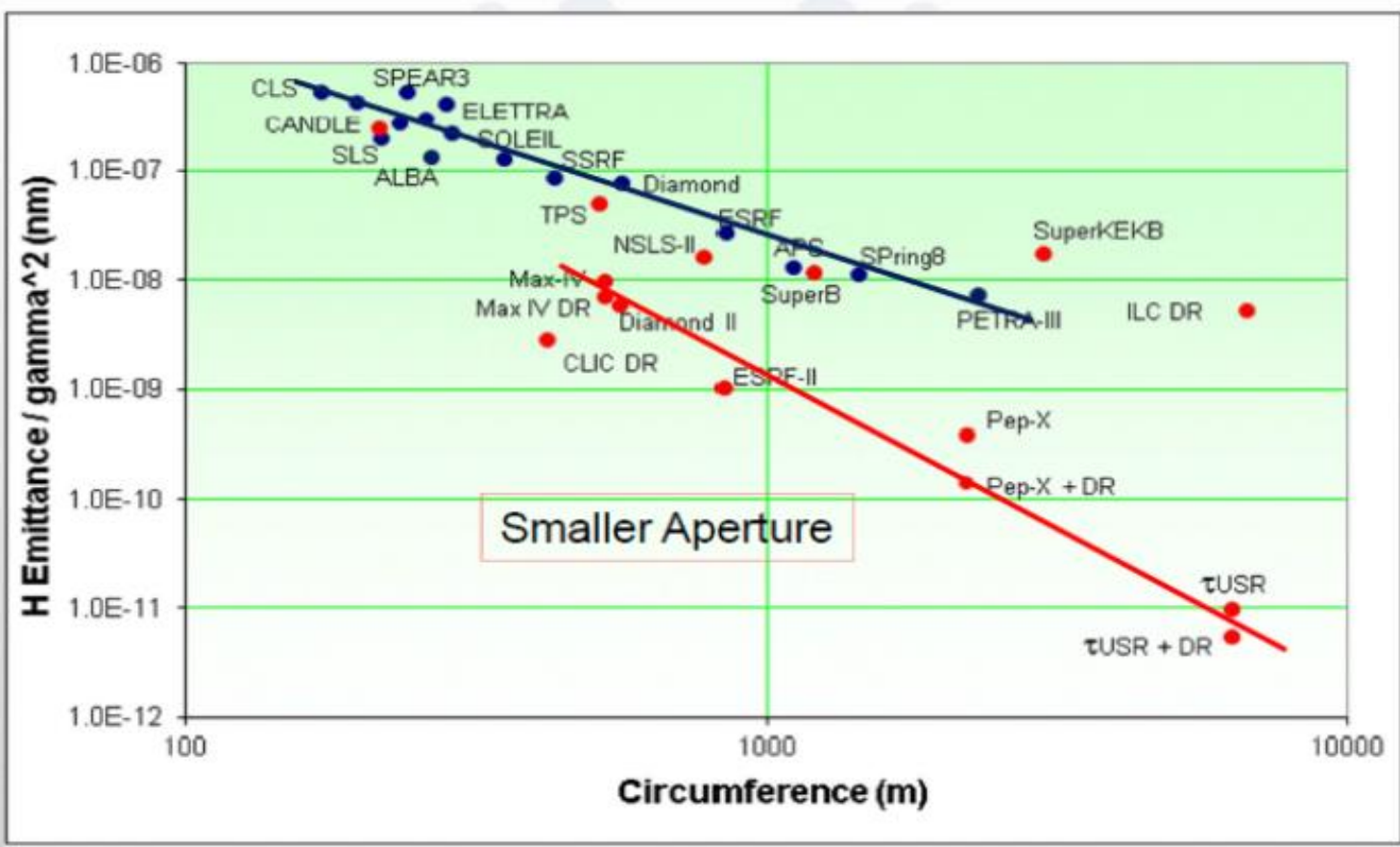

Many thanks to the colleagues providing me with with some material:
Andreas Streun, Emanuel Karantzoulis, Eugene Levichev, Riccardo Bartolini, Michael Borland, Hamed Tarawneh, etc.