

# LHCb Status Report

Vanya Belyaev (ITEP/Moscow)  
for LHCb Collaboration





# LHC, LHCb and three friends

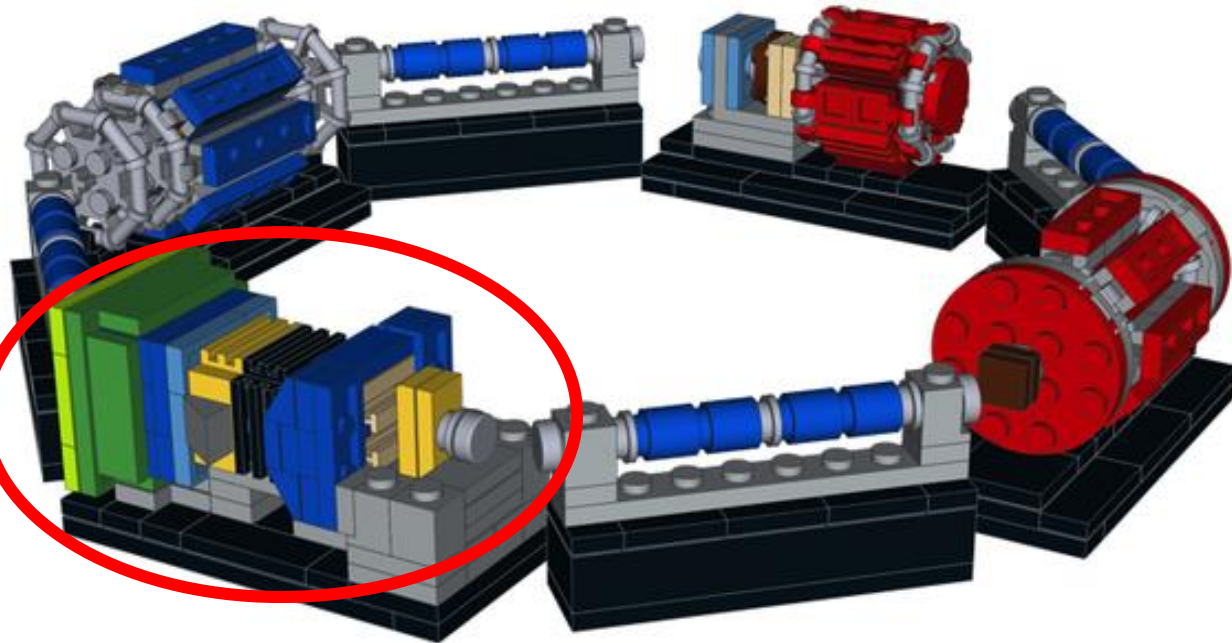
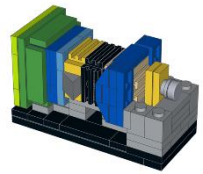

LHCb

Complementarity

[ideas.lego.com/projects/94885](https://ideas.lego.com/projects/94885)





~40% of heavy quarks in <4% of  $4\pi$

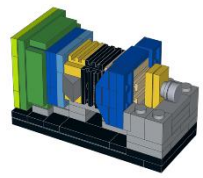

RICH Detectors:

95%  $\epsilon(K^\pm)$  @5%  $\pi \rightarrow K$  misID

Muon:

$\epsilon(\mu^\pm)=97\%$  @1-3%  $\pi \rightarrow \mu$  misID

pp-interaction point

Vertex Locator

O(50fs) resolution for B

The most precise  $\tau(B)$

Tracking:

$\Delta p/p = 0.5-0.6\%$  for  $5 < p < 100$  GeV/c

The most precise B-masses

ECAL:  $\sigma_m(\pi^0)=7\text{MeV}/c^2$

Universality



# Run I

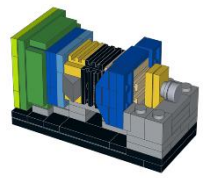

$1\text{fb}^{-1}@7\text{TeV}$

$2\text{fb}^{-1}@8\text{TeV}$

$3.3\text{pb}^{-1}@2.76\text{TeV}$

$1.6\text{nb}^{-1}\text{ pA \& Ap}$

LHCb Efficiency breakdown pp collisions 2010-2012

- FULLY ON: 93.05 (%)
- HV: 0.54 (%)
- VELO Safety: 0.85 (%)
- DAQ: 2.85 (%)
- DeadTime: 2.88 (%)

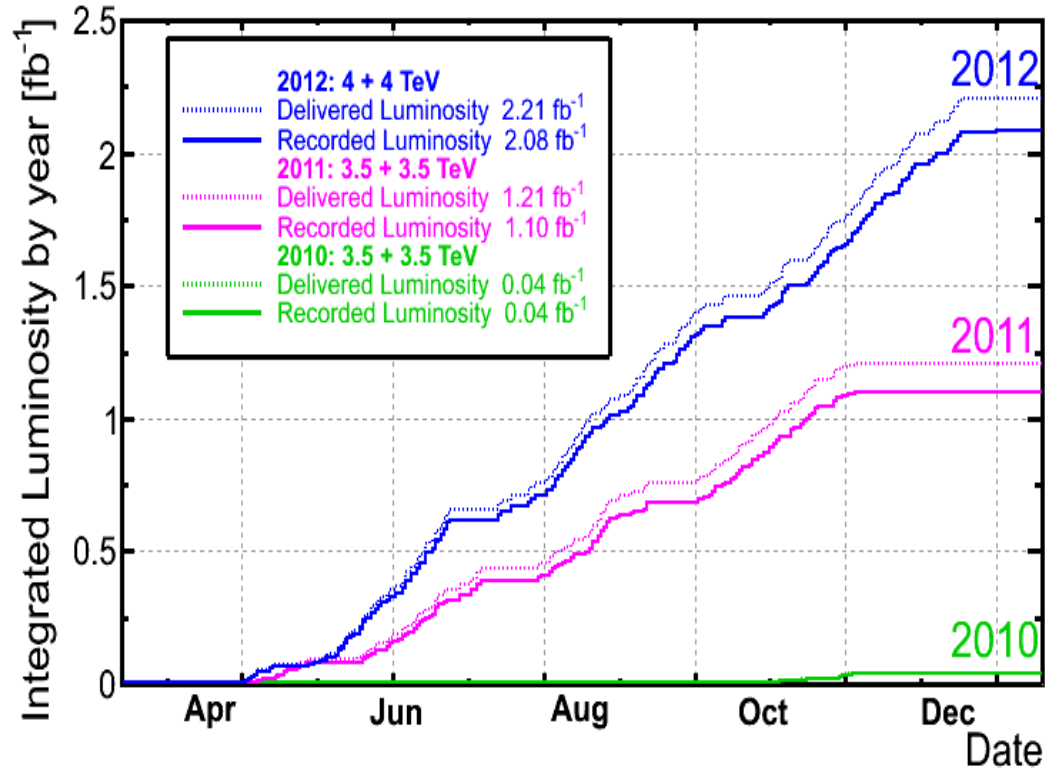
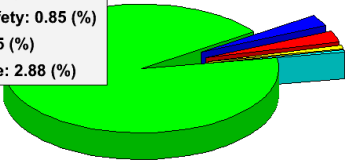

*Thanks to LHC accelerator team for the excellent performance of machine*





# 241 papers submitted 4/03/15

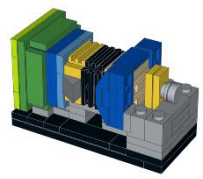

- Good rate is kept: 15 new results in 14 weeks since last LHCC
- This week is special: 6 new results are being shown for the first time at *La Thuile*
  - *Moriond EW* and *Moriond QCD* are soon
- Today:
  - 15 posters for LHCC

Poster

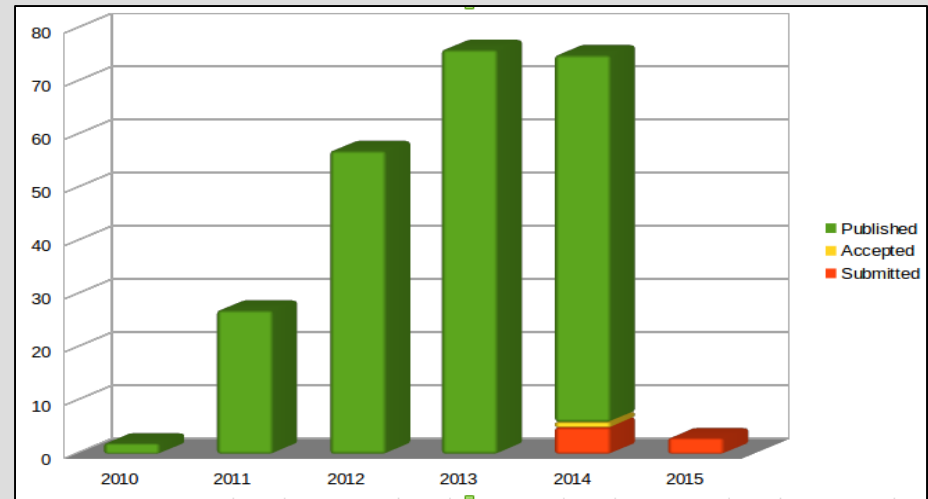

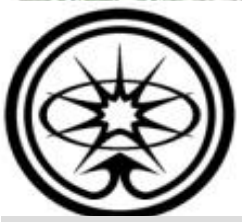

# New papers since last LHCC

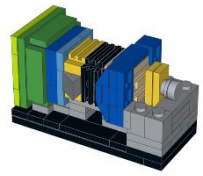

LHCb-PAPER-2014-057 “Measurement of inelastic  $pp$  cross-section at a centre-of-mass energy of  $\sqrt{s}=7\text{TeV}$ ”, submitted to JHEP, [arXiv:1412.2500](#)

LHCb-PAPER-2014-060 “Measurement of the lifetime of the  $B_c$  meson using  $B_c \rightarrow J/\psi \pi^+$  decay mode, [Phys.Lett B742 \(2015\)](#)”

LHCb-PAPER-2014-062 “Search for long-lived particles decaying to jet pairs”, submitted to EPJC, [arXiv:1412.3021](#)

LHCb-PAPER-2014-063 “Study of rare  $B_s$  and  $B^0$  decays in  $\pi^+ \pi^- \mu^+ \mu^-$  final state”, accepted by PLB, [arXiv:1412.6433](#)

LHCb-PAPER-2014-064 “Determination of the branching fractions of  $B_s \rightarrow D_s K$  and  $B^0 \rightarrow D_s K$ ”, submitted to JHEP, [arXiv:1412.7654](#)

LHCb-PAPER-2014-066 “Angular analysis of the  $B^0 \rightarrow K^{*0} e^+ e^-$  decay in the low- $q^2$  region”, submitted to JHEP, [arXiv:1501.03038](#)

LHCb-PAPER-2014-067 “Precise measurement of the properties of the  $B_1(5721)^{0,+}$  and  $B_2(5747)^{0,+}$  and observation of  $B^{+,0} \pi^{\mp,+}$  mass structures”, submitted to JHEP, [arXiv:1502.02638](#)

LHCb-PAPER-2014-068 “Measurement of CP asymmetries and polarization fractions in  $B_s \rightarrow K^{*0} \bar{K}^{*0}$ ”

LHCb-PAPER-2014-069 “Measurement of indirect CP asymmetries in  $D^0 \rightarrow K^- K^+$  and  $D^0 \rightarrow \pi^- \pi^+$  decays”, submitted to JHEP, [arXiv:1501.06777](#)

LHCb-PAPER-2015-003 “Measurement of forward  $Z \rightarrow e^+ e^-$  production at  $\sqrt{s}=8\text{TeV}$ ”

LHCb-PAPER-2015-004 “Measurement of CP violation in  $B^0 \rightarrow J/\psi K_S$ ”

LHCb-PAPER-2015-005 “Search for CP-violation in  $B_s \rightarrow J/\psi K_S$ ”

LHCb-PAPER-2015-006 “Amplitude analysis of  $B^0 \rightarrow (\pi^+ \pi^-)(\pi^+ \pi^-)$  and first observation of  $B^0 \rightarrow \rho^0 \rho^0$ ”

LHCb-PAPER-2015-007 “First observation and amplitude analysis of the  $B^- \rightarrow D^+ K^- \pi^-$ ”

LHCb-PAPER-2015-009 “Differential branching fractions and angular analysis of  $\Lambda_b \rightarrow \Lambda^0 \mu^+ \mu^-$ ”





# *1fb<sup>-1</sup>* vs Full Run 1 dataset

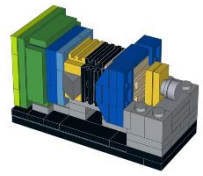

LHCb-PAPER-2014-057 “Measurement of inelastic  $pp$  cross-section at a centre-of-mass energy of  $\sqrt{s}=7\text{TeV}$ ”, submitted to JHEP, [arXiv:1412.2500](#)

LHCb-PAPER-2014-060 “Measurement of the lifetime of the  $B_c$  meson using  $B_c \rightarrow J/\psi\pi^+$  decay mode”, [Phys.Lett B742 \(2015\)](#)

LHCb-PAPER-2014-062 “Search for long-lived particles decaying to jet pairs”, submitted to EPJC, [arXiv:1412.3021](#)

LHCb-PAPER-2014-063 “Study of rare  $B_s$  and  $B^0$  decays in  $\pi^+\pi^-\mu^+\mu^-$  final state”, accepted by PLB, [arXiv:1412.6433](#)

LHCb-PAPER-2014-064 “Determination of the branching fractions of  $B_s \rightarrow D_s K$  and  $B^0 \rightarrow D_s K$ ”, submitted to JHEP, [arXiv:1412.7654](#)

LHCb-PAPER-2014-066 “Angular analysis of the  $B^0 \rightarrow K^{*0}e^+e^-$  decay in the low- $q^2$  region”, submitted to JHEP, [arXiv:1501.03038](#)

LHCb-PAPER-2014-067 “Precise measurement of the properties of the  $B_1(5721)^{0,+}$  and  $B_2(5747)^{0,+}$  and observation of  $B^{+,0}\pi^{\mp,+}$  mass structures”, submitted to JHEP, [arXiv:1502.02638](#)

LHCb-PAPER-2014-068 “Measurement of CP asymmetries and polarization fractions in  $B_s \rightarrow K^{*0}\bar{K}^{*0}$ ”

LHCb-PAPER-2014-069 “Measurement of indirect CP asymmetries in  $D^0 \rightarrow K^-K^+$  and  $D^0 \rightarrow \pi^-\pi^+$  decays”, submitted to JHEP, [arXiv:1501.06777](#)

LHCb-PAPER-2015-003 “Measurement of forward  $Z \rightarrow e^+e^-$  production at  $\sqrt{s}=8\text{TeV}$ ”

LHCb-PAPER-2015-004 “Measurement of CP violation in  $B^0 \rightarrow J/\psi K_S$ ”

LHCb-PAPER-2015-005 “Search for CP-violation in  $B_s \rightarrow J/\psi K_S$ ”

LHCb-PAPER-2015-006 “Amplitude analysis of  $B^0 \rightarrow (\pi^+\pi^-)(\pi^+\pi^-)$  and first observation of  $B^0 \rightarrow \rho^0\rho^0$ ”

LHCb-PAPER-2015-007 “First observation and amplitude analysis of the  $B^- \rightarrow D^+K^-\pi^-$ ”

LHCb-PAPER-2015-009 “Differential branching fractions and angular analysis of  $\Lambda_b \rightarrow \Lambda^0\mu^+\mu^-$ ”



# Beauty&Charm decays, QCD, EW & Exotica

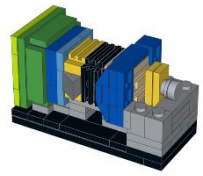

LHCb-PAPER-2014-057 “Measurement of inelastic  $pp$  cross-section at a centre-of-mass energy of  $\sqrt{s}=7\text{TeV}$ ”, submitted to JHEP, [arXiv:1412.2500](#)

LHCb-PAPER-2014-060 “Measurement of the lifetime of the  $B_c$  meson using  $B_c \rightarrow J/\psi\pi^+$  decay mode”, Phys.Lett B742 (2015)

LHCb-PAPER-2014-062 “Search for long-lived particles decaying to jet pairs”, submitted to EPJC, [arXiv:1412.3021](#)

LHCb-PAPER-2014-063 “Study of rare  $B_s$  and  $B^0$  decays in  $\pi^+\pi^-\mu^+\mu^-$  final state”, accepted by PLB, [arXiv:1412.6433](#)

LHCb-PAPER-2014-064 “Determination of the branching fractions of  $B_s \rightarrow D_s K$  and  $B^0 \rightarrow D_s K$ ”, submitted to JHEP, [arXiv:1412.7654](#)

LHCb-PAPER-2014-066 “Angular analysis of the  $B^0 \rightarrow K^{*0}e^+e^-$  decay in the low- $q^2$  region”, submitted to JHEP, [arXiv:1501.03038](#)

LHCb-PAPER-2014-067 “Precise measurement of the properties of the  $B_1(5721)^{0,+}$  and  $B_2(5747)^{0,+}$  and observation of  $B^{+,0}\pi^{\mp,+}$  mass structures”, submitted to JHEP, [arXiv:1502.02638](#)

LHCb-PAPER-2014-068 “Measurement of CP asymmetries and polarization fractions in  $B_s \rightarrow K^{*0}\bar{K}^{*0}$ ”

LHCb-PAPER-2014-069 “Measurement of indirect CP asymmetries in  $D^0 \rightarrow K^-K^+$  and  $D^0 \rightarrow \pi^-\pi^+$  decays”, submitted to JHEP, [arXiv:1501.06777](#)

LHCb-PAPER-2015-003 “Measurement of forward  $Z \rightarrow e^+e^-$  production at  $\sqrt{s}=8\text{TeV}$ ”

LHCb-PAPER-2015-004 “Measurement of CP violation in  $B^0 \rightarrow J/\psi K_S$ ”

LHCb-PAPER-2015-005 “Search for CP violation in  $B_s \rightarrow J/\psi K_S$ ”

LHCb-PAPER-2015-006 “Amplitude analysis of  $B^0 \rightarrow (\pi^+\pi^-)(\pi^+\pi^-)$  and first observation of  $B^0 \rightarrow \rho^0\rho^0$ ”

LHCb-PAPER-2015-007 “First observation and amplitude analysis of the  $B^- \rightarrow D^+K^-\pi^-$ ”

LHCb-PAPER-2015-009 “Differential branching fractions and angular analysis of  $\Lambda_b \rightarrow \Lambda^0\mu^+\mu^-$ ”

Universality





# Hot-n-fresh La Thuile 2k+15

This week!

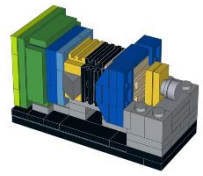

LHCb-PAPER-2014-057 “Measurement of inelastic  $pp$  cross-section at a center-of-mass energy of  $\sqrt{s}=8\text{TeV}$ ”, submitted to JHEP, [arXiv:1412.2500](https://arxiv.org/abs/1412.2500)

LHCb-PAPER-2014-060 “Measurement of the lifetime of the  $B_c$  meson using  $B_c \rightarrow \mu^+ \mu^-$  decays”, submitted to JHEP, [arXiv:1501.03038](https://arxiv.org/abs/1501.03038) (2015)

LHCb-PAPER-2014-062 “Search for long-lived particles decaying to jet pairs”, submitted to EPJC, [arXiv:1412.3021](https://arxiv.org/abs/1412.3021)

LHCb-PAPER-2014-063 “Study of rare  $B_s$  and  $B^0$  decays in  $\pi^+ \pi^- \mu^+ \mu^-$  final state”, accepted by PLB, [arXiv:1412.6433](https://arxiv.org/abs/1412.6433)

LHCb-PAPER-2014-064 “Determination of the branching fractions of  $B_s \rightarrow D_s K$  and  $B^0 \rightarrow D_s K$ ”, submitted to JHEP, [arXiv:1412.7654](https://arxiv.org/abs/1412.7654)

LHCb-PAPER-2014-066 “Angular analysis of the  $B^0 \rightarrow K^{*0} e^+ e^-$  decay in the low- $q^2$  region”, submitted to JHEP, [arXiv:1501.03038](https://arxiv.org/abs/1501.03038)

LHCb-PAPER-2014-067 “Precise measurement of the properties of the  $B_1(5721)^{0,+}$  and  $B_2(5747)^{0,+}$  and observation of  $B^{+,0} \pi^{\mp,+}$  mass structures”, submitted to JHEP, [arXiv:1502.02638](https://arxiv.org/abs/1502.02638)

LHCb-PAPER-2014-068 “Measurement of CP asymmetries and polarization fractions in  $B_s \rightarrow K^{*0} \bar{K}^{*0}$ ” **This afternoon**

LHCb-PAPER-2014-069 “Measurement of indirect CP asymmetries in  $D^0 \rightarrow K^- K^+$  and  $D^0 \rightarrow \pi^- \pi^+$  decays”, submitted to JHEP, [arXiv:1501.06777](https://arxiv.org/abs/1501.06777)

LHCb-PAPER-2015-003 “Measurement of forward  $Z \rightarrow e^+ e^-$  production at  $\sqrt{s}=8\text{TeV}$ ”

LHCb-PAPER-2015-004 “Measurement of CP violation in  $B^0 \rightarrow J/\psi K_S$ ”

**Tomorrow**

LHCb-PAPER-2015-005 “Search for CP-violation in  $B_s \rightarrow J/\psi K_S$ ”

LHCb-PAPER-2015-006 “Amplitude analysis of  $B^0 \rightarrow (\pi^+ \pi^-)(\pi^+ \pi^-)$  and first observation of  $B^0 \rightarrow \rho^0 \rho^0$ ” **This afternoon**

LHCb-PAPER-2015-007 “First observation and amplitude analysis of the  $B^- \rightarrow D^+ K^- \pi^-$ ”

LHCb-PAPER-2015-009 “Differential branching fractions and angular analysis of  $\Lambda_b \rightarrow \Lambda^0 \mu^+ \mu^-$ ”

**This morning**

**4 March 2k+15, LHCC 121st meeting**

**Vanya Belyaev "LHCb Status Report"**





# Inelastic pp cross-section

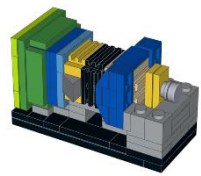

LHCb-PAPER-2014-057 arXiv:1412.2500

- Use 2010 data,  $\sqrt{s}=7\text{TeV}$ ,  $L=2\text{nb}^{-1}$  with very low pileup
- Cross-section for at least one track with  $p_T > 200\text{MeV}/c$  and  $2.0 < \eta < 4.5$   
 $\sigma = 55.0 \pm 2.4\text{mb}$  Systematic dominates:  $\sigma(L) = 3.5\%$  (for 2010 data)
- Extrapolation to  $4\pi$   
Pythia 8.201

1.7% for 2k+11  
1.2% for 2k+12

$\sigma = 66.9 \pm 2.9_{(\text{exp})} \pm 4.4_{(\text{ext})}\text{mb}$

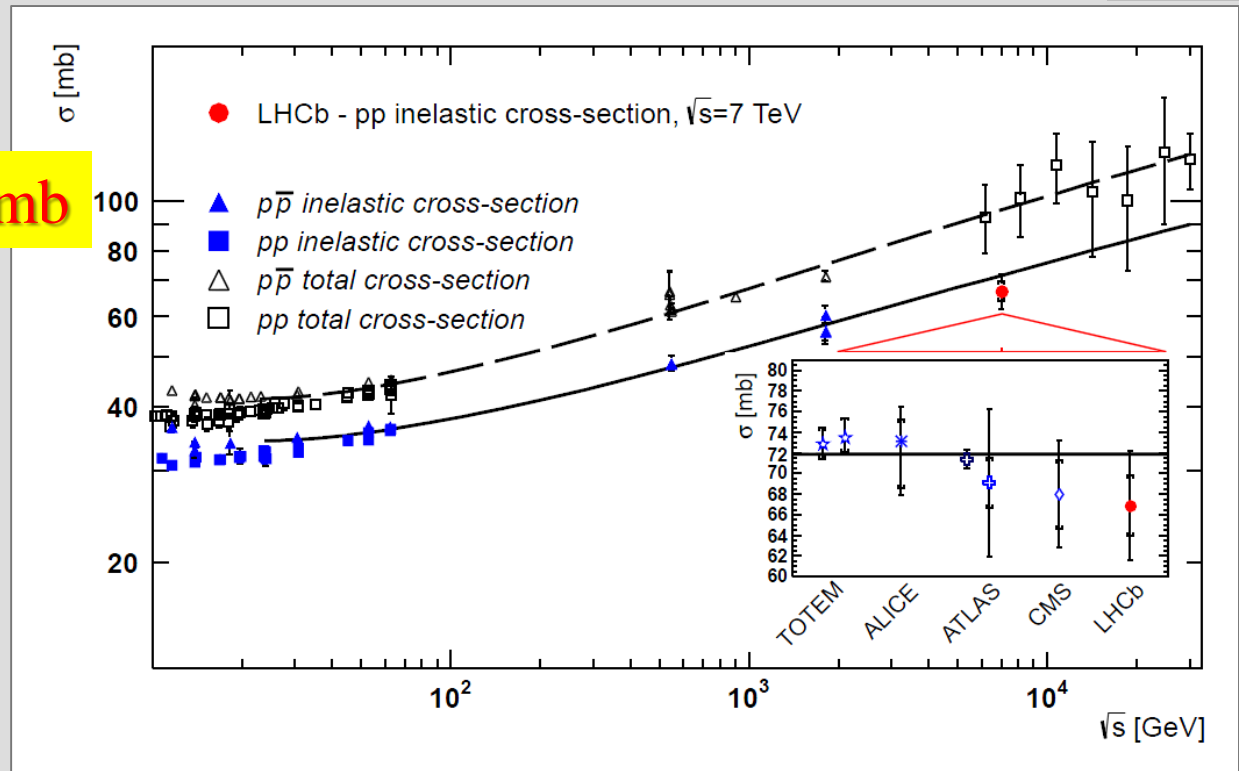

The measurement for all LHC detectors..

Synergy





Poster

# Massive Long-lived particles

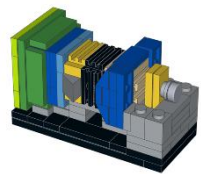

[LHCb-PAPER-2014-062](#) [arXiv:1412.3021](#)

- Generic search for heavy  $25 < m < 50 \text{ GeV}/c^2$  long-lived  $1 < t < 200 \text{ ps}$  particles via *displaced two-jet vertices*
- *Hidden Valley*  $H \rightarrow \pi_\nu \pi_\nu$  as benchmark

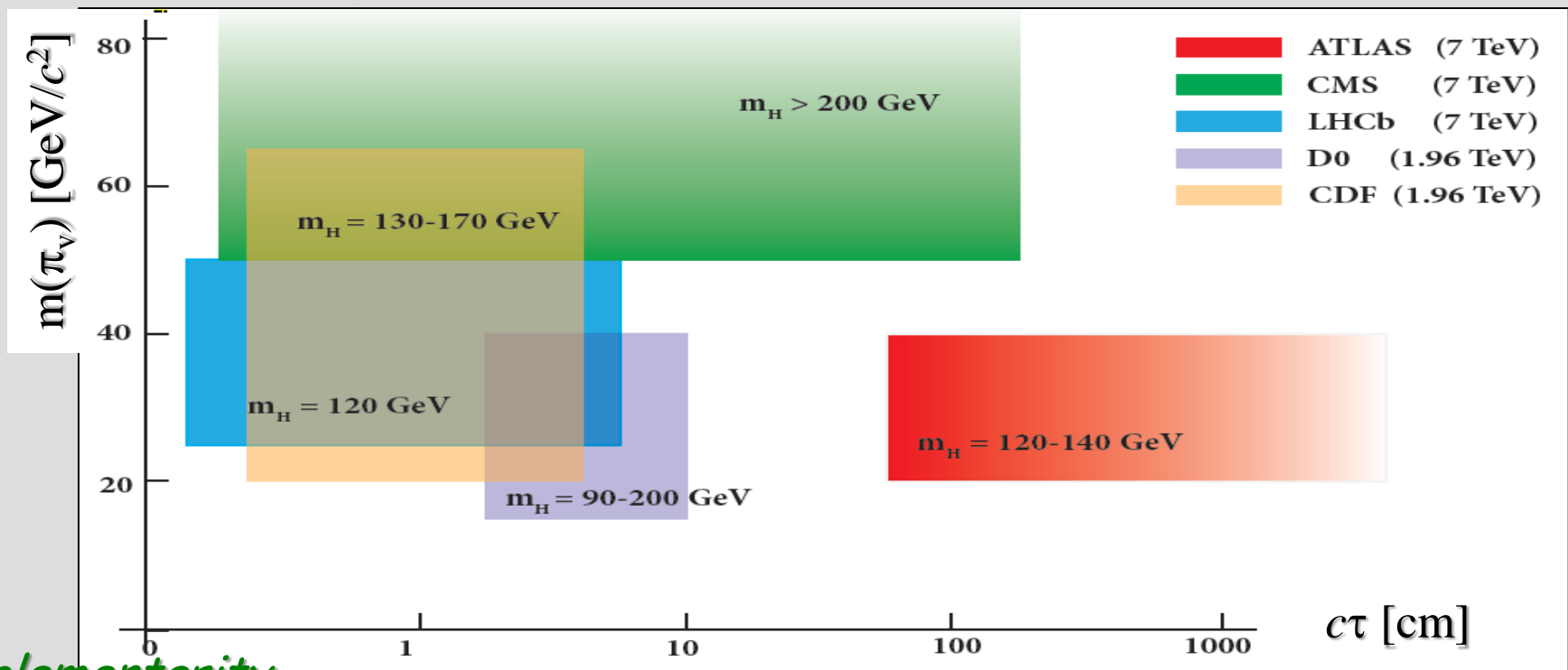

Complementarity



# Massive Long-lived particles

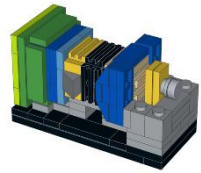

Poster

LHCb-PAPER-2014-062 [arXiv:1412.3021](https://arxiv.org/abs/1412.3021)

- Reconstruct  $\pi_{\nu} \rightarrow b\bar{b}$  with two b-tagged jets
- "Material veto"
- Fit mass in 5 bins  $R_{xy}$ 
  - no signal is observed

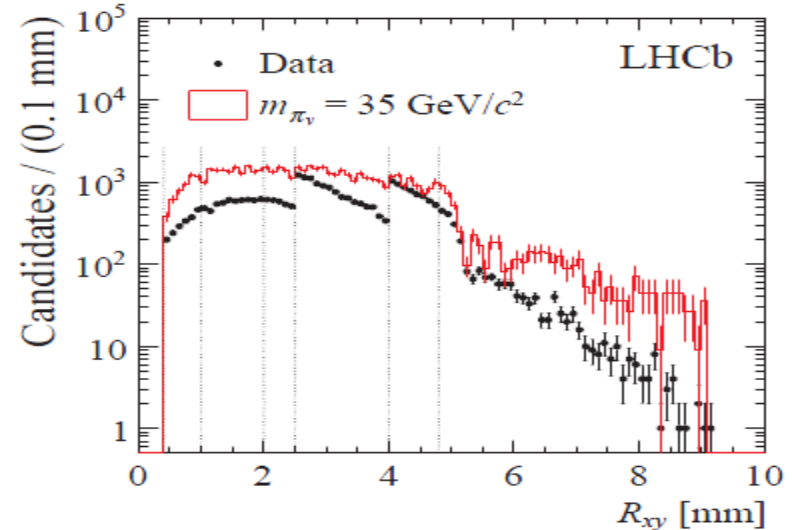
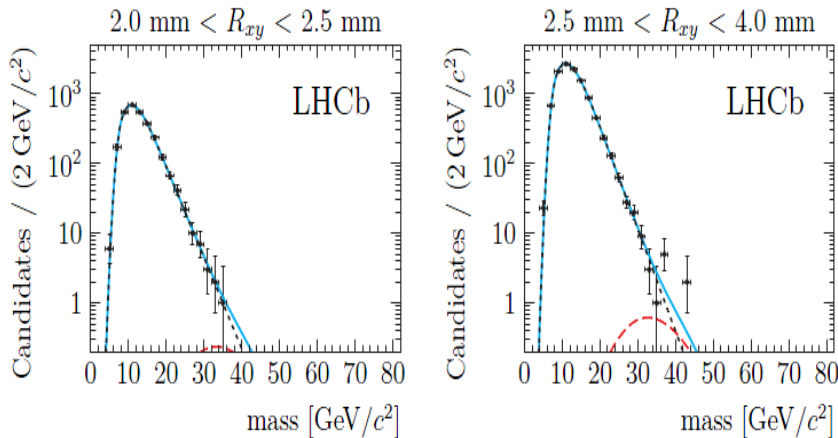
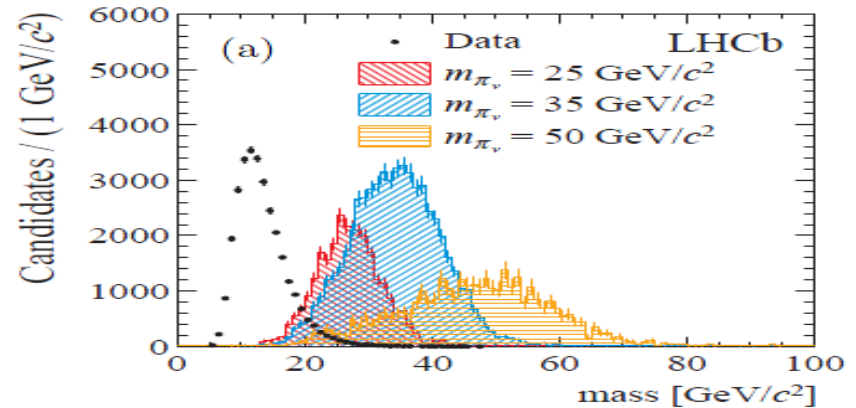



# Massive Long-lived particles

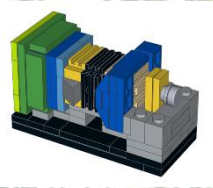

Upper limits are better for decays into light quarks:

- Large multiplicity
- Smaller jet mass

[LHCb-PAPER-2014-062](#) [arXiv:1412.3021](#)

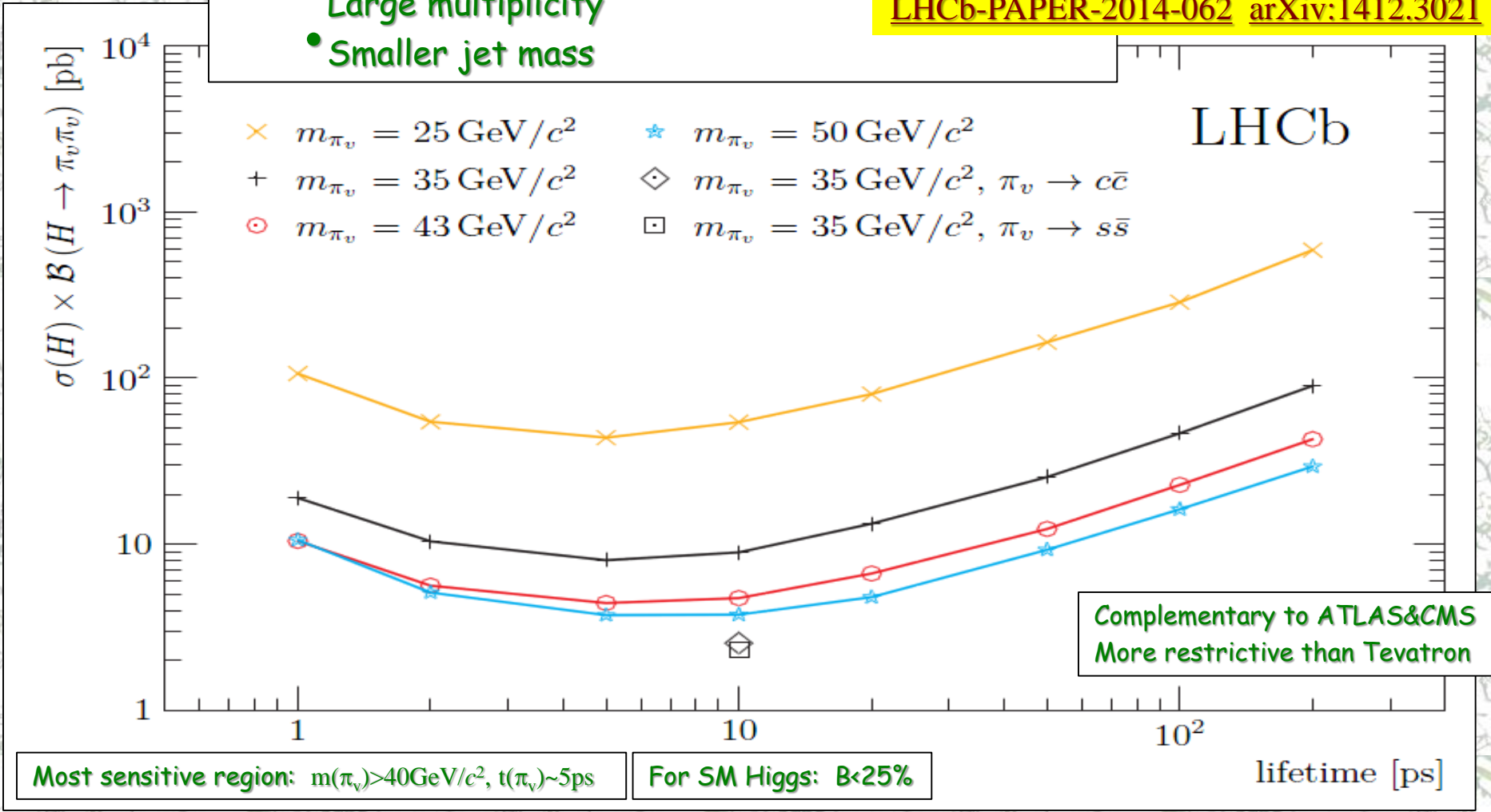





# B\*\*

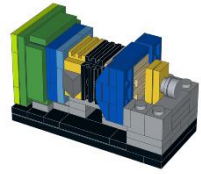

LHCb-PAPER-2014-067 arXiv:1502.02638

- A lot of B\*\* states are predicted. Only two are measured (D0, CDF)
  - Important for understanding HQET
- 1.2M B<sup>0</sup> in 3 modes  
 2.5M B<sup>+</sup> in 3 modes  
 Purity >80% for all cases

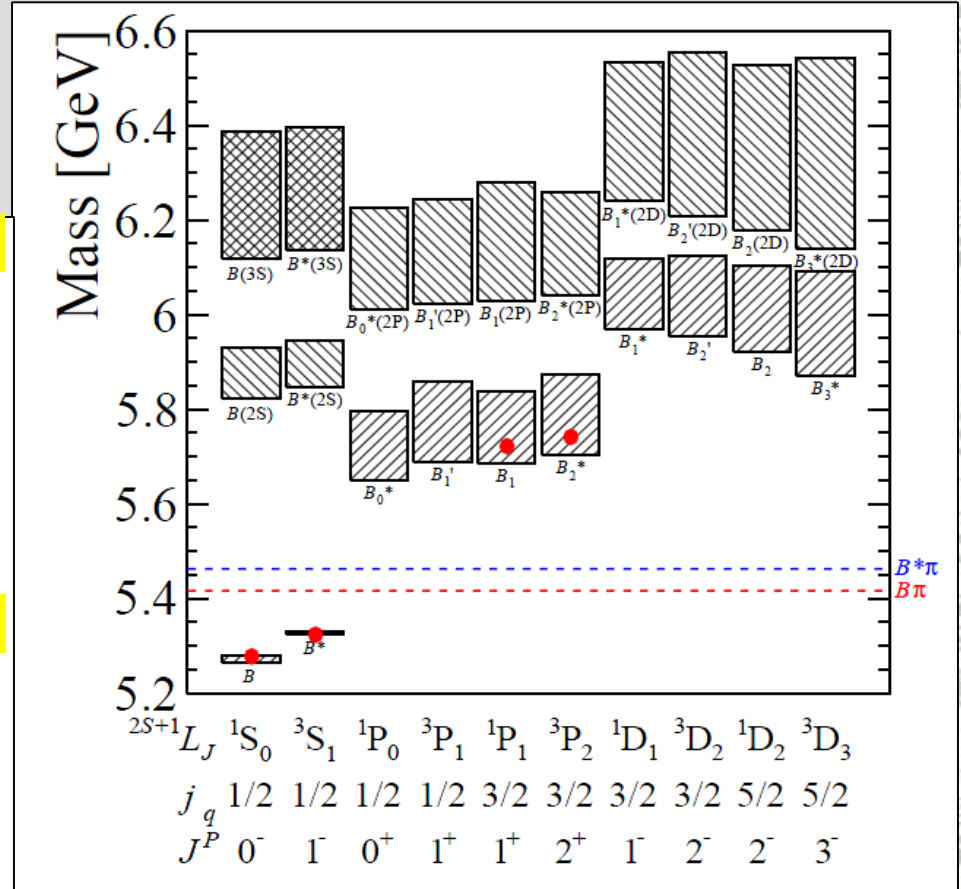
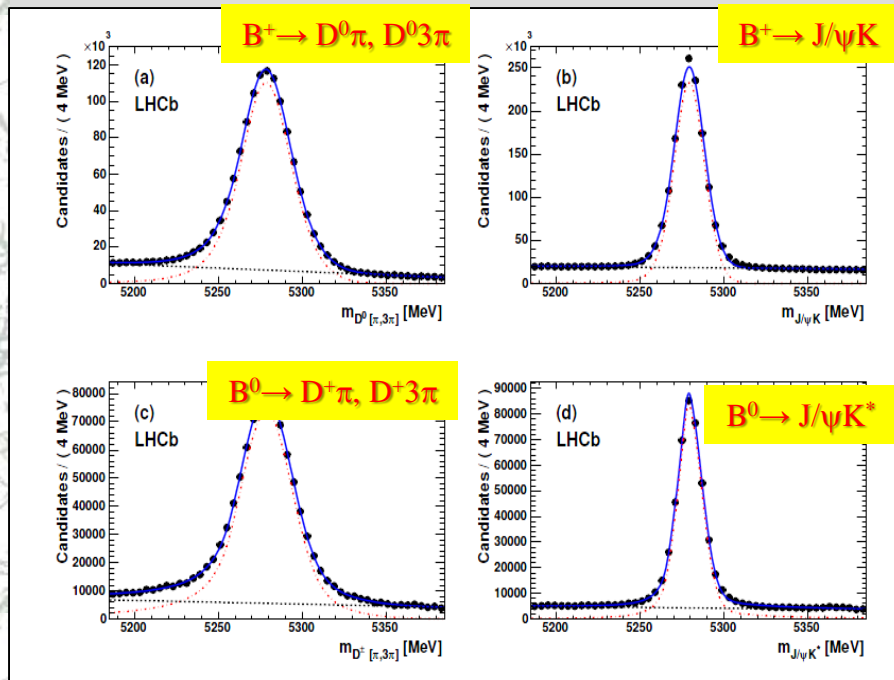



# $B_1(5721)^{0,+}$ & $B_2(5747)^{0,+}$

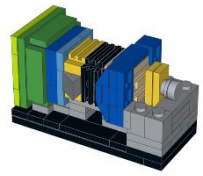

LHCb-PAPER-2014-067 arXiv:1502.02638

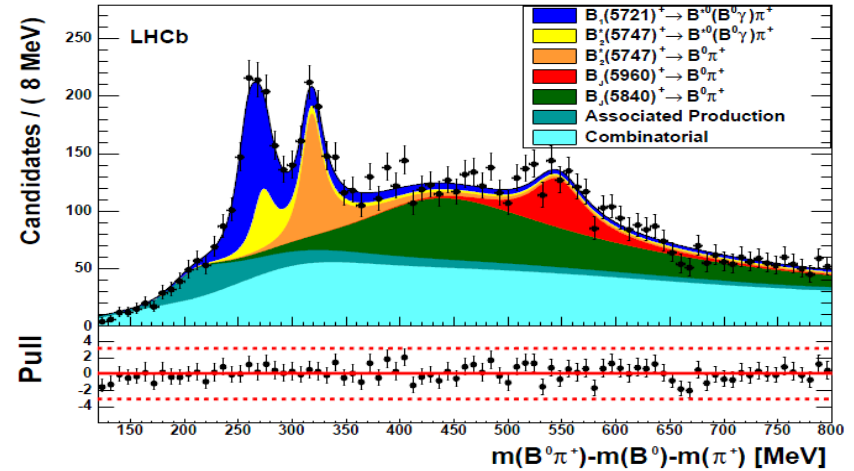
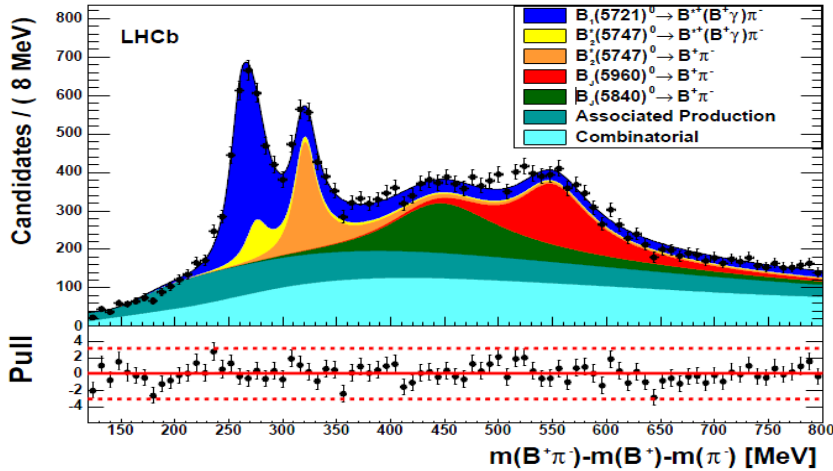

$m_{B_1(5721)^0}$	$=$	$5727.7$	$\pm 0.7$	$\pm 1.4$	$\pm 0.17$	$\pm 0.4$	MeV,
$m_{B_2^*(5747)^0}$	$=$	$5739.44$	$\pm 0.37$	$\pm 0.33$	$\pm 0.17$		MeV,
$m_{B_1(5721)^+}$	$=$	$5725.1$	$\pm 1.8$	$\pm 3.1$	$\pm 0.17$	$\pm 0.4$	MeV,
$m_{B_2^*(5747)^+}$	$=$	$5737.20$	$\pm 0.72$	$\pm 0.40$	$\pm 0.17$		MeV,
$\Gamma_{B_1(5721)^0}$	$=$	$30.1$	$\pm 1.5$	$\pm 3.5$			MeV,
$\Gamma_{B_2^*(5747)^0}$	$=$	$24.5$	$\pm 1.0$	$\pm 1.5$			MeV,
$\Gamma_{B_1(5721)^+}$	$=$	$29.1$	$\pm 3.6$	$\pm 4.3$			MeV,
$\Gamma_{B_2^*(5747)^+}$	$=$	$23.6$	$\pm 2.0$	$\pm 2.1$			MeV.
		stat		syst	m(B)	m(B*)-m(B)	

The most precise measurement

$$\frac{\mathcal{B}(B_2^*(5747)^0 \rightarrow B^{*+}\pi^-)}{\mathcal{B}(B_2^*(5747)^0 \rightarrow B^+\pi^-)} = 0.71 \pm 0.14 \pm 0.30,$$

$$\frac{\mathcal{B}(B_2^*(5747)^+ \rightarrow B^{*0}\pi^+)}{\mathcal{B}(B_2^*(5747)^+ \rightarrow B^0\pi^+)} = 1.0 \pm 0.5 \pm 0.8,$$

Significance for  $B^*\pi > 3.7\sigma$   
(syst. included)



# If high mass structures are resonances...

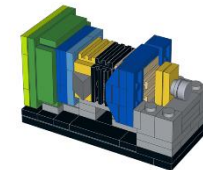

LHCb-PAPER-2014-067 arXiv:1502.02638

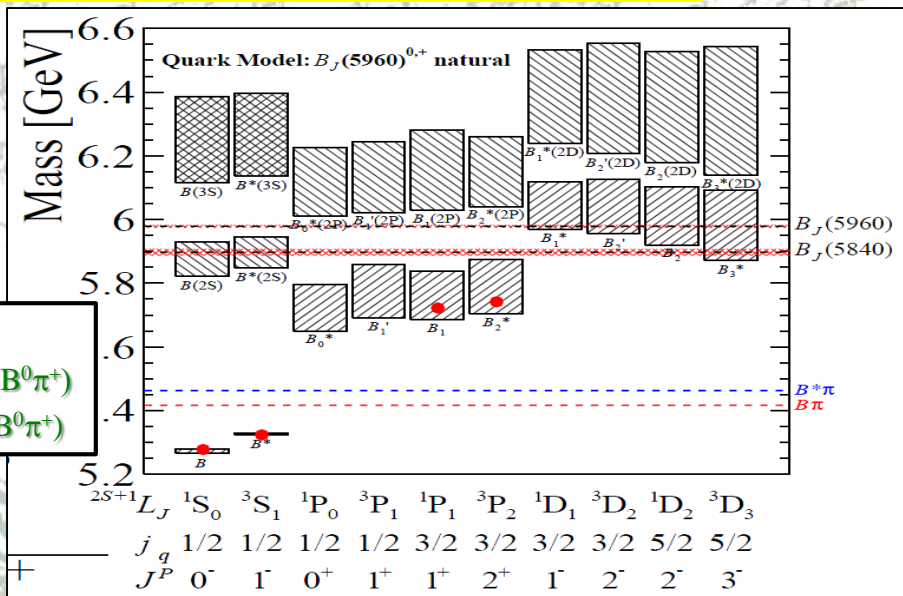
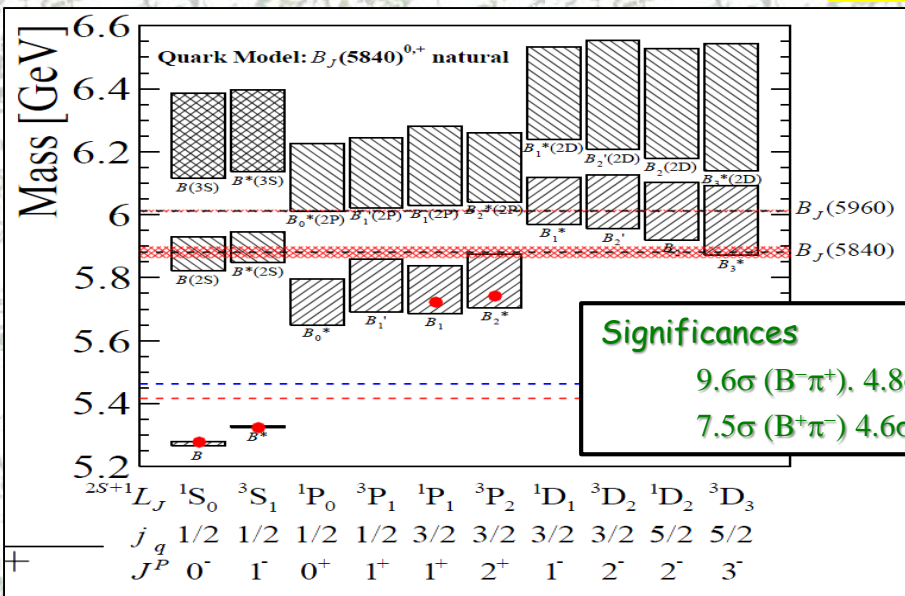

$B_J(5960)^{0,+}$  parameters are close to measurement by CDF but more precise.

In quark models  $B_J(5840)$  and  $B_J(5960)$  would correspond to  $B(2S)$  and  $B^*(2S)$

Fit parameter	$B^+\pi^-$	$B^0\pi^+$
$B_J(5840)^{0,+} \mu$	$471 \pm 22$	$455 \pm 26$
$B_J(5840)^{0,+} \Gamma$	$107 \pm 20$	$215 \pm 27$
$B_J(5960)^{0,+} \mu$	$552 \pm 4$	$547 \pm 4$
$B_J(5960)^{0,+} \Gamma$	$82 \pm 10$	$61 \pm 15$

Fit parameter	$B^+\pi^-$	$B^0\pi^+$
$B_J(5840)^{0,+} \mu$	$444 \pm 5$	$425 \pm 15$
$B_J(5840)^{0,+} \Gamma$	$119 \pm 17$	$229 \pm 27$
$B_J(5960)^{0,+} \mu$	$575 \pm 6$	$547 \pm 5$
$B_J(5960)^{0,+} \Gamma$	$56 \pm 7$	$61 \pm 14$





# Rare semileptonic decays and angular analyses

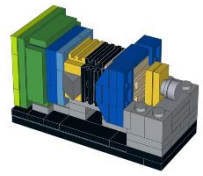

Powerfull way to look for New Physics: Higgses, Supersymmetry, etc..

- Rare semileptonic penguin decays are in the centre of LHCb physics program, e.g.  $B \rightarrow K^* \mu \mu$
- Many observables accessible through angular analysis (in  $q^2$  bins) have reduced hadronic uncertainties and thus allow probing of New Physics
- $B \rightarrow K^* e^+ e^-$  allows study of (very) low  $q^2$  region (dominated by virtual photon): sensitivity to right currents
- $\Lambda_b \rightarrow \Lambda^0 \mu^+ \mu^-$  has different helicity structure; different hadronic uncertainties -  $\Lambda_b$  is "simpler" than  $B^0$ -meson;  $\Lambda_0$  is own polarimeter ...

LHCb-PAPER-2014-066 arXiv:1501.03038

Results of  $3\text{fb}^{-1}$  analysis is being reported *just now* at La Thuile

More news on semileptonic penguins in pipeline

$$H_{\text{eff}} = -\frac{4G_F}{\sqrt{2}} V_{tb} V_{ts}^* \sum_i \left[ \underbrace{C_i(\mu) O_i(\mu)}_{\text{left-handed part}} + \underbrace{C'_i(\mu) O'_i(\mu)}_{\text{right-handed part suppressed in SM}} \right]$$

- i=1,2 Tree
- i=3-6,8 Gluon penguin
- i=7 Photon penguin
- i=9,10 Electroweak penguin
- i=S Higgs (scalar) penguin
- i=P Pseudoscalar penguin

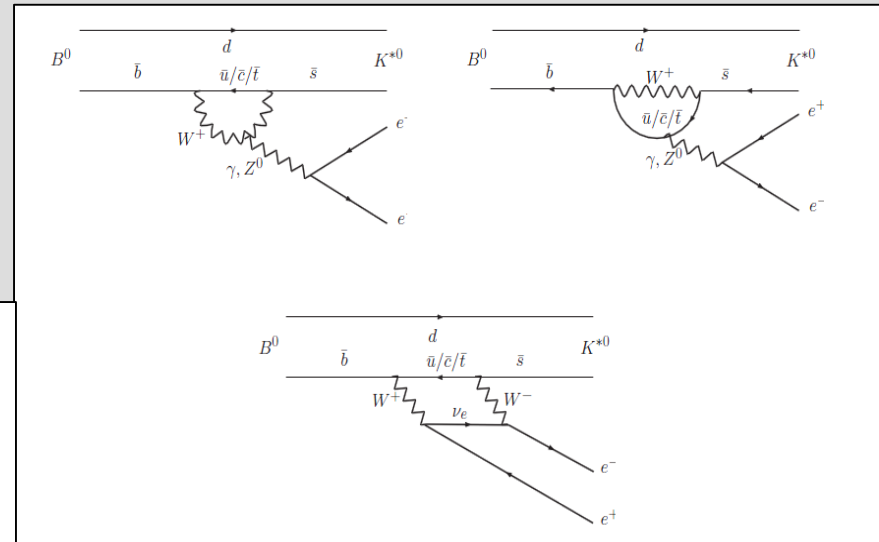



Poster

# $B^0 \rightarrow K^{*0} e^+ e^-$ at low $q^2$

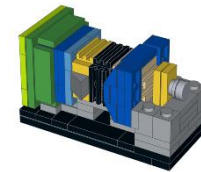

LHCb-PAPER-2014-066 arXiv:1501.03038

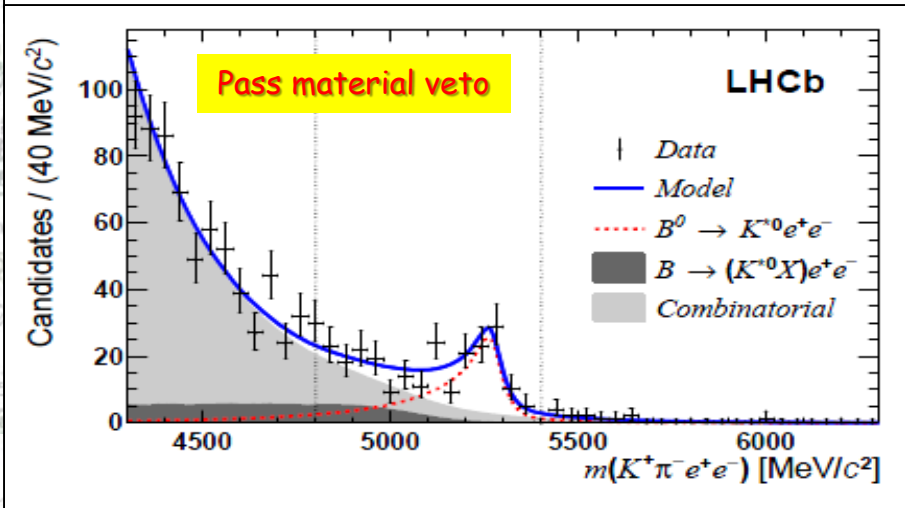
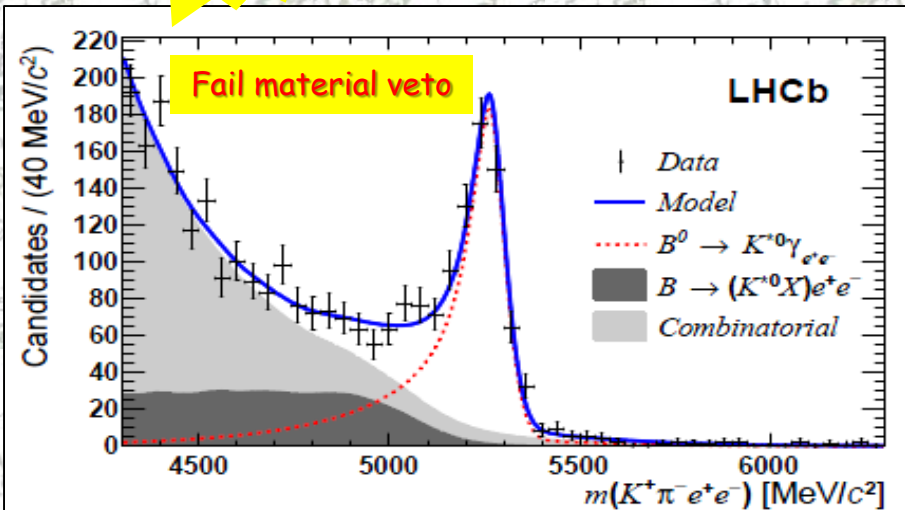

## $0.0004 < q^2 < 1 \text{ GeV}^2/c^4$

- Degradation of angular resolution at very low  $q^2$

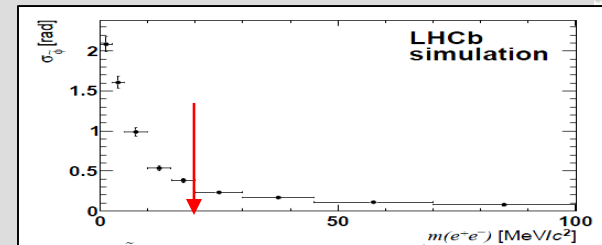

- Dominant background  $B^0 \rightarrow K^{*0} \gamma$  with conversion: Material veto!
- Signal:  $150 \pm 17 B^0 \rightarrow K^{*0} e^+ e^-$  events

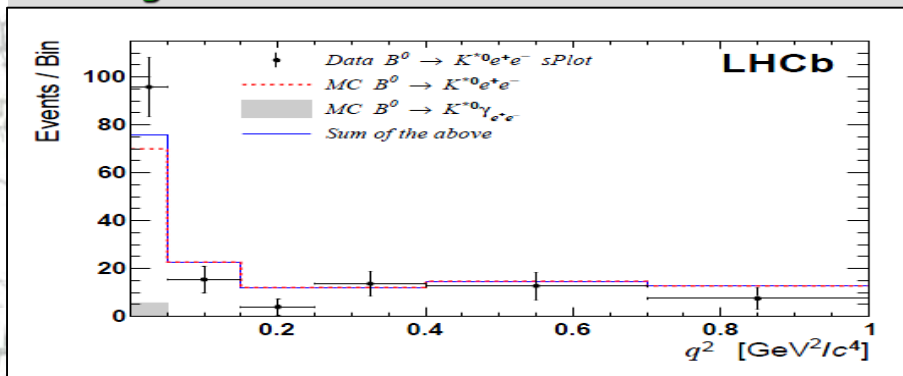



Poster

# $B^0 \rightarrow K^{*0} e^+ e^-$ at low $q^2$

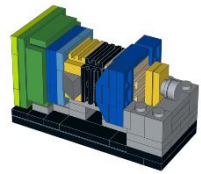

LHCb-PAPER-2014-066 arXiv:1501.03038

- Angular analysis  $\cos \theta_1$ ,  $\cos \theta_K$  and *folded*  $\phi$

$$\begin{aligned}
 F_L &= 0.16 \pm 0.06 \pm 0.03 \\
 A_T^{(2)} &= -0.23 \pm 0.23 \pm 0.05 \\
 A_T^{\text{Im}} &= +0.14 \pm 0.22 \pm 0.05 \\
 A_T^{\text{Re}} &= +0.10 \pm 0.18 \pm 0.05,
 \end{aligned}$$

Contours based on B-factory results

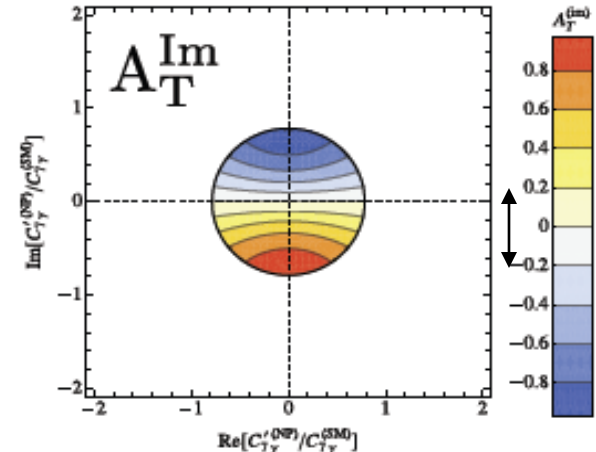
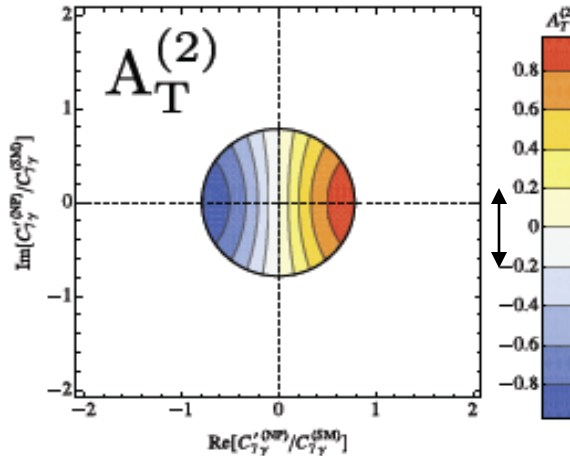
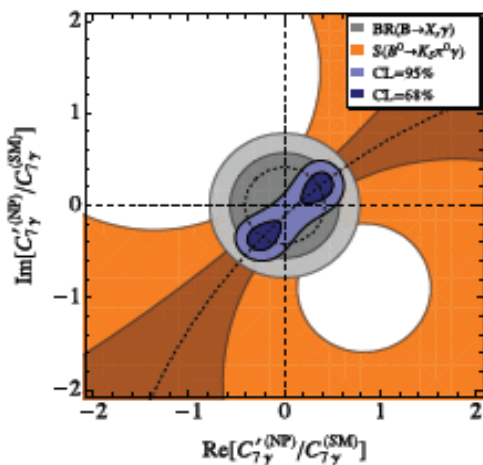

Becirevic et al. JHEP 08 (2012) 090





Poster

$$\Lambda_b \rightarrow \Lambda^0 \mu^+ \mu^-$$

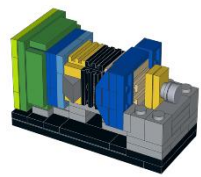

LHCb-PAPER-2015-009

- Different spin structure probes helicity structure of Hamiltonian
- Different hadronic uncertainties
  - $\Lambda_b$  is somehow a bit more simple than  $B^0$
- Weakly decaying  $\Lambda^0$  allows to determine helicity
- New analysis,  $3\text{fb}^{-1}$ 
  - $\sim 300$  events
- *Differential decay rate and full angular analysis*

*The result is being reported just now  
for the first time at La Thuile conference*

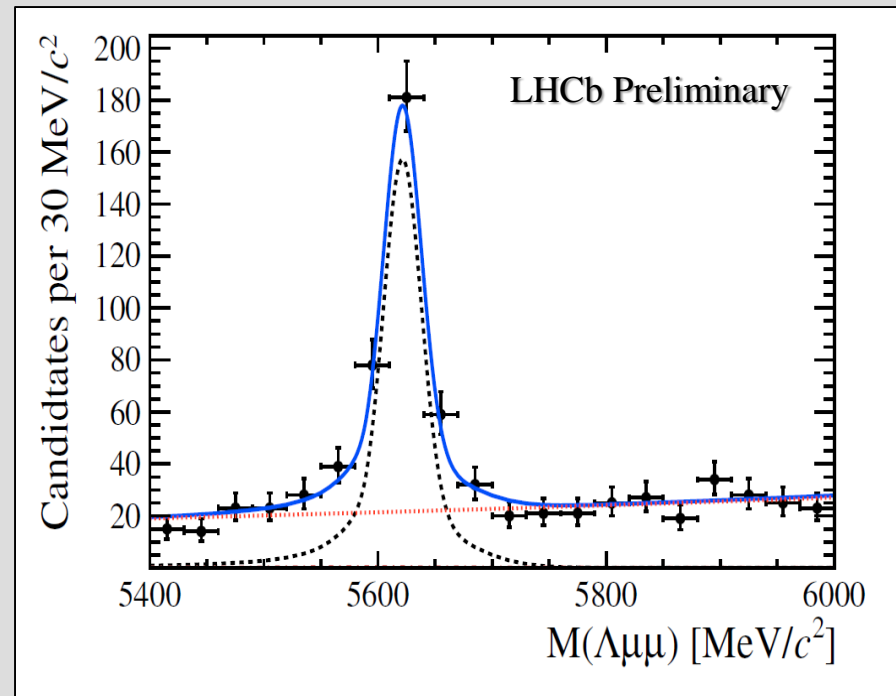



# Study of rare $B_s$ and $B^0$ decays in $\pi^+\pi^-\mu^+\mu^-$ final state

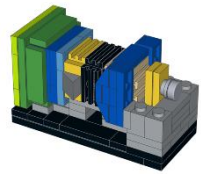

Poster

LHCb-PAPER-2014-063 arXiv:1412.6433

- $B_s \rightarrow f^0 \mu^+ \mu^-$  in SM: sum of  $b \rightarrow s$  penguin and box contributions
- $B^0 \rightarrow \rho^0 \mu^+ \mu^-$  in SM sum of  $b \rightarrow d$  penguin (suppressed as  $|V_{td}/V_{ts}|^2$ ) and box
- $\phi \rightarrow \mu^+ \mu^-$   $J/\psi \rightarrow \mu^+ \mu^-$  and  $\psi' \rightarrow \mu^+ \mu^-$  are excluded

$J/\psi \pi^+ \pi^-$

Signals:  $\pi^+ \pi^- \mu^+ \mu^-$

Normalization:  $B^0 \rightarrow J/\psi K^{*0}$

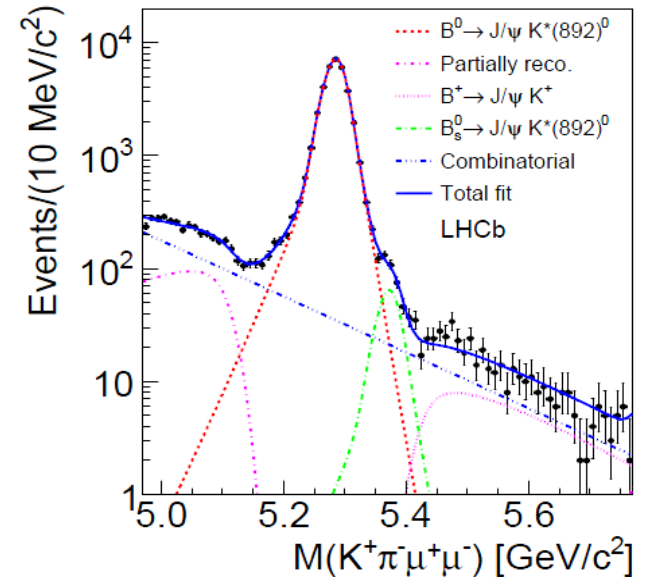
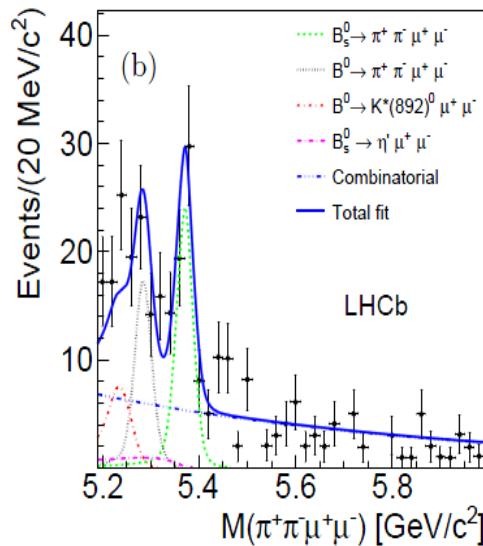
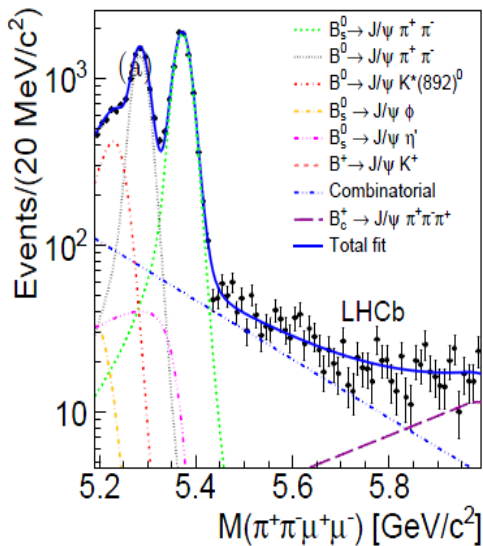



# Study of rare $B_s$ and $B^0$ decays in $\pi^+\pi^-\mu^+\mu^-$ final state

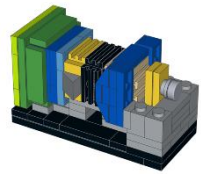

Poster

LHCb-PAPER-2014-063 arXiv:1412.6433

- $B_s \rightarrow \pi^+\pi^-\mu^+\mu^-$  Significance  $7.3\sigma$
- $B^0 \rightarrow \pi^+\pi^-\mu^+\mu^-$  Significance  $4.8\sigma$

$$\frac{\mathcal{B}(B_s^0 \rightarrow \pi^+\pi^-\mu^+\mu^-)}{\mathcal{B}(B^0 \rightarrow J/\psi(\rightarrow \mu^+\mu^-)K^*(892)^0(\rightarrow K^+\pi^-))} = (1.67 \pm 0.29 (\text{stat}) \pm 0.13 (\text{syst})) \times 10^{-3},$$

$$\frac{\mathcal{B}(B_s^0 \rightarrow \pi^+\pi^-\mu^+\mu^-)}{\mathcal{B}(B^0 \rightarrow J/\psi(\rightarrow \mu^+\mu^-)K^*(892)^0(\rightarrow K^+\pi^-))} = (0.41 \pm 0.10 (\text{stat}) \pm 0.03 (\text{syst})) \times 10^{-3}.$$

$$\mathcal{B}(B_s^0 \rightarrow \pi^+\pi^-\mu^+\mu^-) = (8.6 \pm 1.5 (\text{stat}) \pm 0.7 (\text{syst}) \pm 0.7 (\text{norm})) \times 10^{-8} \text{ and}$$

$$\mathcal{B}(B^0 \rightarrow \pi^+\pi^-\mu^+\mu^-) = (2.11 \pm 0.51 (\text{stat}) \pm 0.15 (\text{syst}) \pm 0.16 (\text{norm})) \times 10^{-8},$$

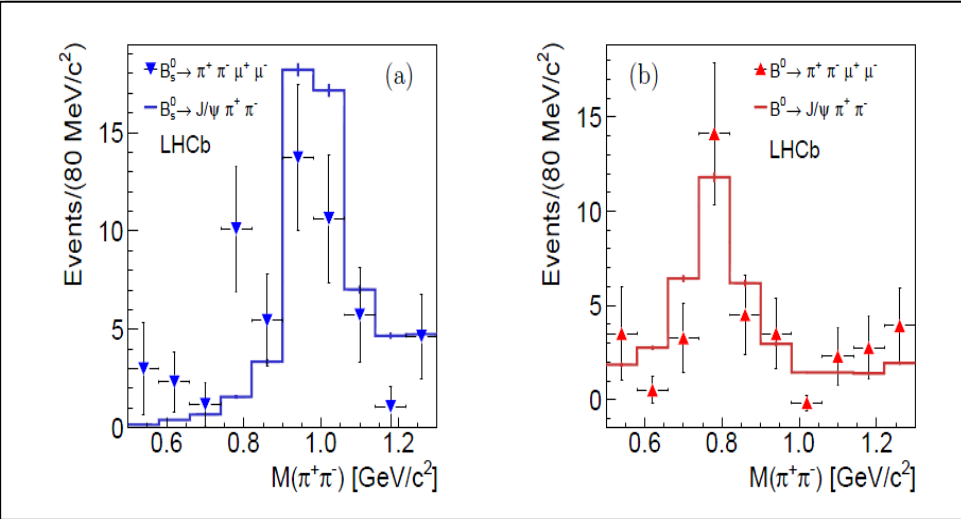

$\text{Br}(B_s^0 \rightarrow f_0(980)\mu^+\mu^-)$	
$(5.21_{-2.06}^{+3.23}) \times 10^{-7}$	[PRD79,014013]
$(9.5_{-2.6}^{+3.1}) \times 10^{-8}$	[PRD81,074001]
$(1.67 \pm 0.61) \times 10^{-7}$	[PRD81,074001]
$(0.81 - 2.02) \times 10^{-8}$	[PRD80,016009]
$(0.63 - 3.37) \times 10^{-9}$	[PRD80,016009]
$\text{Br}(B^0 \rightarrow \rho(770)^0\mu^+\mu^-)$	
$(5.0_{-2.6}^{+2.1}) \times 10^{-8}$	[PRD56,5452]
	[HEP-PH/9609503]
$(8.6_{-4.5}^{+3.4}) \times 10^{-8}$	[PRD53,3672]
	[HEP-PH/9609503]





# B-meson decays into two vector mesons

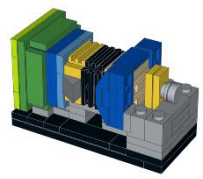

LHCb-PAPER-2014-068, LHCb-PAPER-2015-006

- Amplitude analysis of  $B^0 \rightarrow (\pi^+\pi^-)(\pi^+\pi^-)$ 
  - Colour suppressed
  - Powerful constraint for angle  $\alpha$  of unitarity triangle
  - Evidence from Belle and BaBar  $f_L = \frac{|A_{\rho\rho}^0|^2}{|A_{\rho\rho}^0|^2 + |A_{\rho\rho}^{\parallel}|^2 + |A_{\rho\rho}^{\perp}|^2}$ 
    - Large difference in longitudinal polarization fraction
- CP-asymmetries and polarization fractions in  $B_s \rightarrow K^{*0}\bar{K}^{*0}$ 
  - Triple Product asymmetries
  - Polarization fractions for vector current

*Both analyses will be reported for the first time **this afternoon** at La Thuile conference*

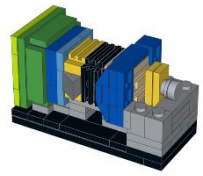

LHCb-PAPER-2015-006

- Rich resonance structure:  $\rho^0, \omega, f_0, f_2, \dots$

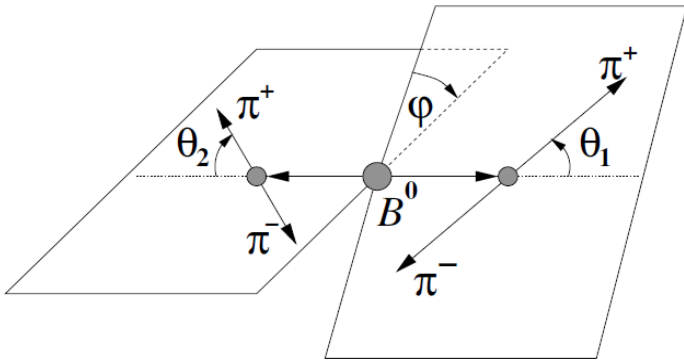

$$\frac{d^5\Gamma}{d\cos\theta_1 d\cos\theta_2 d\varphi dm_1^2 dm_2^2} = \frac{9}{8\pi} \Phi_4(m_1, m_2) \left| \sum_{i=1}^{11} A_i f_i(m_1, m_2, \theta_1, \theta_2, \varphi) \right|^2,$$

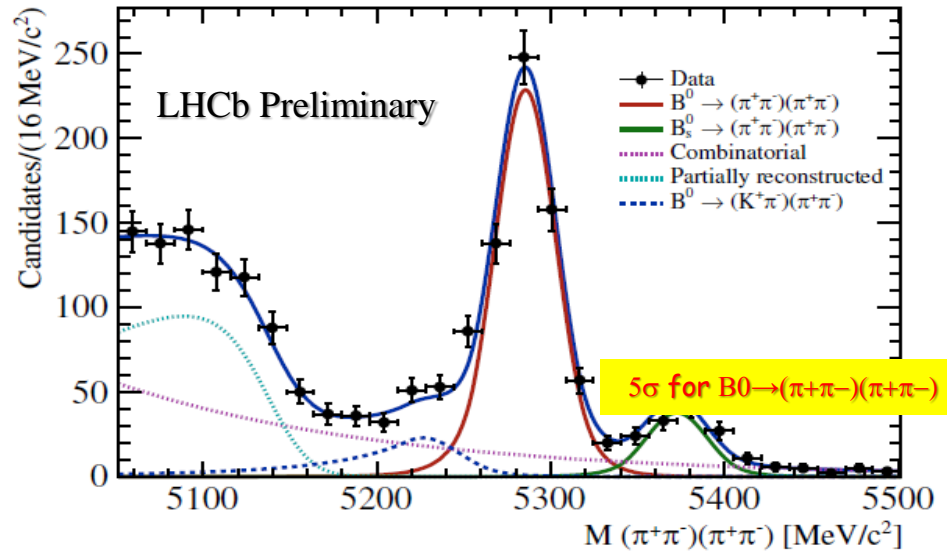

- >600 signal decays
- 11 terms in amplitude analysis



# $B^0 \rightarrow (\pi^+\pi^-)(\pi^+\pi^-)$

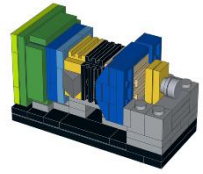

LHCb-PAPER-2015-006

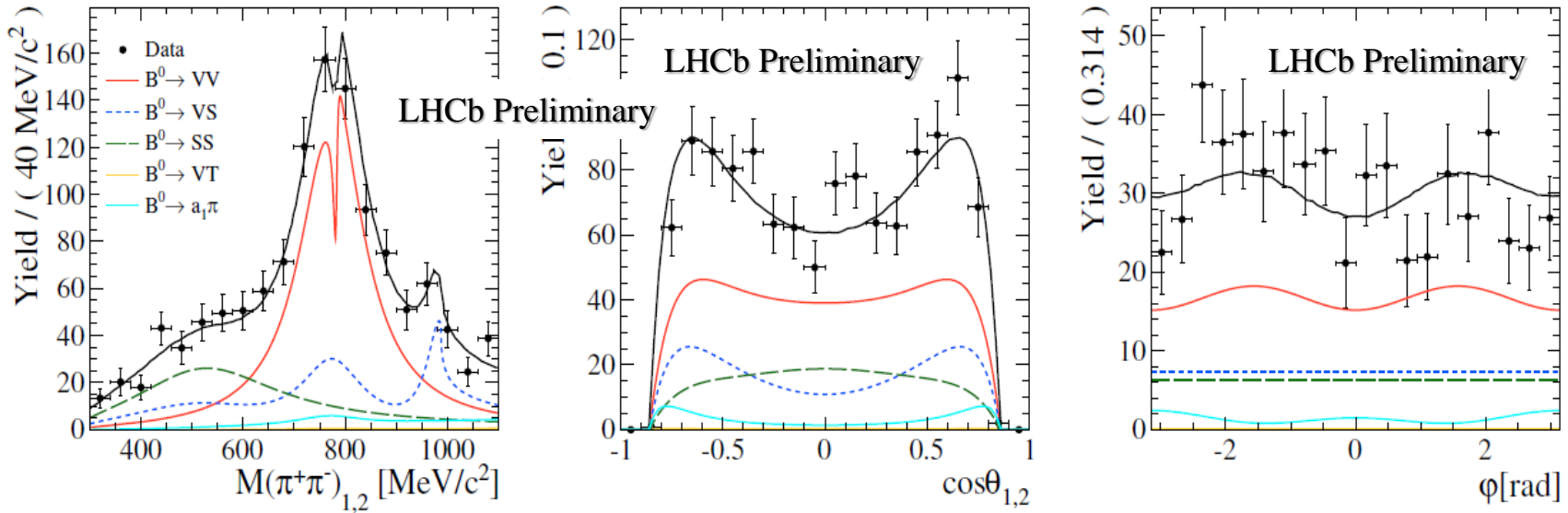

$$f_L = \frac{|A_{\rho\rho}^0|^2}{|A_{\rho\rho}^0|^2 + |A_{\rho\rho}^{\parallel}|^2 + |A_{\rho\rho}^{\perp}|^2}$$

Belle  
 BaBar  
 LHCb 2k+15

$$f_L = 0.21_{-0.26}^{+0.22}$$

$$f_L = 0.75_{-0.15}^{+0.12}$$

$$0.048_{-0.058}^{+0.048} \text{ (stat)} \pm 0.033 \text{ (syst)}$$

Significant improvement  
 in precision!





Poster

# $\sin 2\beta$ from $B^0 \rightarrow J/\psi K_S$

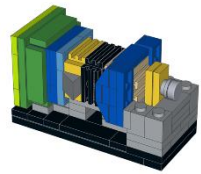

LHCb-PAPER-2015-004

## Golden mode for B-factories

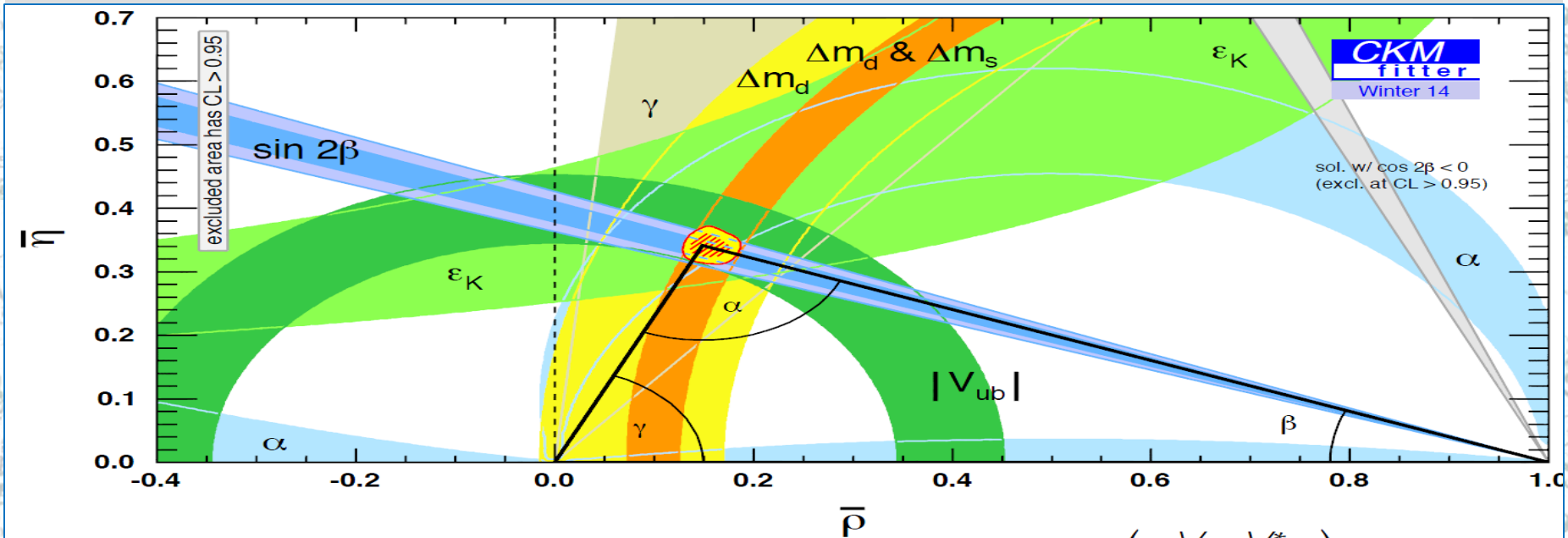

$$V_{ud}V_{ub}^* + V_{cd}V_{cb}^* + V_{td}V_{tb}^* = 0$$

$$\beta = \arg \left( -\frac{V_{cd}V_{cb}^*}{V_{td}V_{tb}^*} \right)$$

► current world average:  $\sin 2\beta = 0.679 \pm 0.020$

**dominated by B-factories**

From global fits:  
 $\sin 2\beta = 0.771^{+0.017}_{-0.041}$

*The analyses has been reported for the first time yesterday afternoon at La Thuile conference*



Poster

# $\sin 2\beta$ from $B^0 \rightarrow J/\psi K_S$

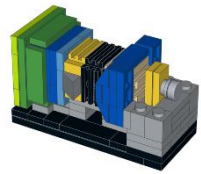

LHCb-PAPER-2015-004

- Full statistic
- Improved tagging
  - For the first time same side pion tag: fragmentation pions and pions from  $B^{*+} \rightarrow B^0 \pi^+$
  - $41560 \pm 210$  flavour tagged decays
- Sophisticated fit
  - Seven dimensions
    - Mass, decay time, decay time uncertainty, tagging categories....
  - 24 disjointed categories
  - 83 floating parameters
  - Make use of measured production asymmetries,  $\Delta m_d$ , ...

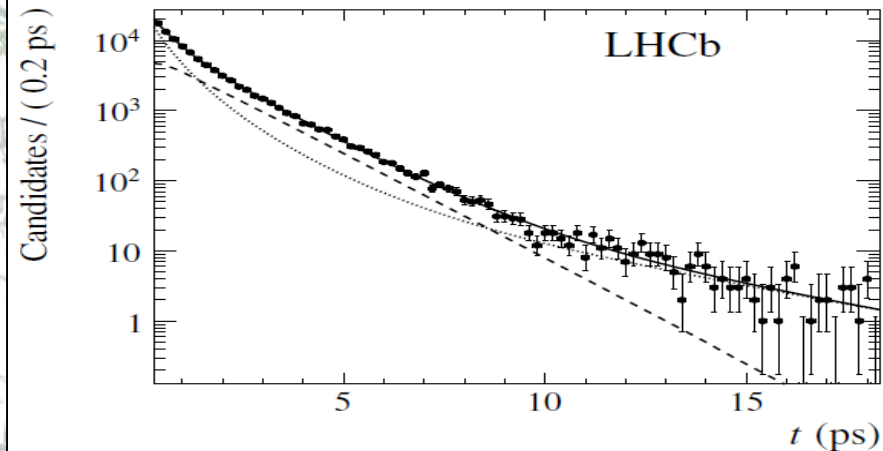
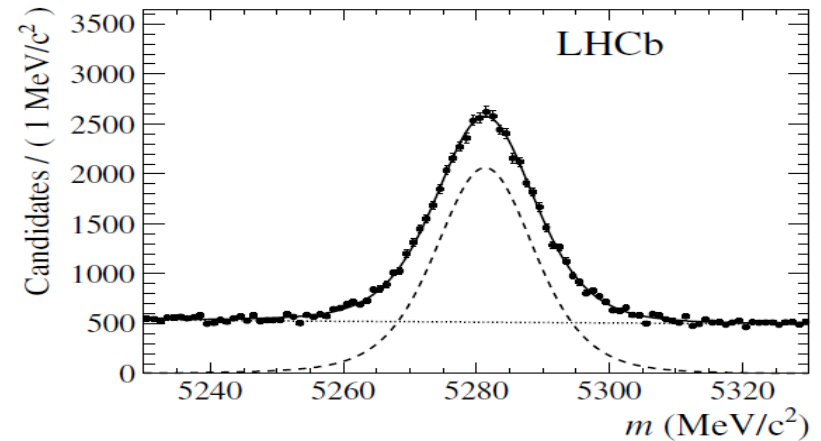



Poster

# sin2β from B<sup>0</sup> → J/ψK<sub>S</sub>

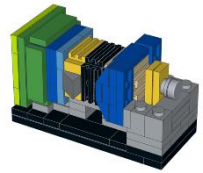

LHCb-PAPER-2015-004

Precision comparable with B-factories, still statistically dominated

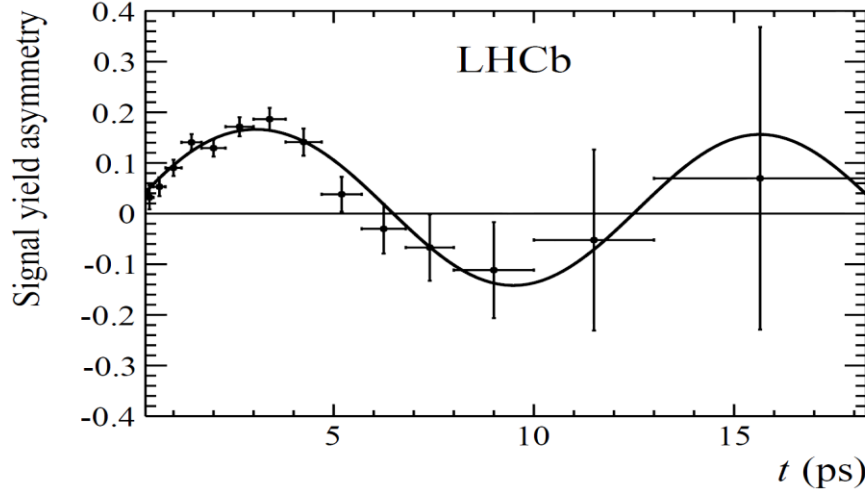

$$A(t) \equiv \frac{\Gamma(\bar{B}^0(t) \rightarrow J/\psi K_S^0) - \Gamma(B^0(t) \rightarrow J/\psi K_S^0)}{\Gamma(\bar{B}^0(t) \rightarrow J/\psi K_S^0) + \Gamma(B^0(t) \rightarrow J/\psi K_S^0)} = \frac{S \sin(\Delta m t) - C \cos(\Delta m t)}{\cosh(\frac{\Delta\Gamma t}{2}) + A_{\Delta\Gamma} \sinh(\frac{\Delta\Gamma t}{2})}$$

$$A(t) = S \sin(\Delta m t) - C \cos(\Delta m t).$$

$$S = 0.729 \pm 0.035 \pm 0.020$$

$$C = -0.033 \pm 0.032 \pm 0.005$$

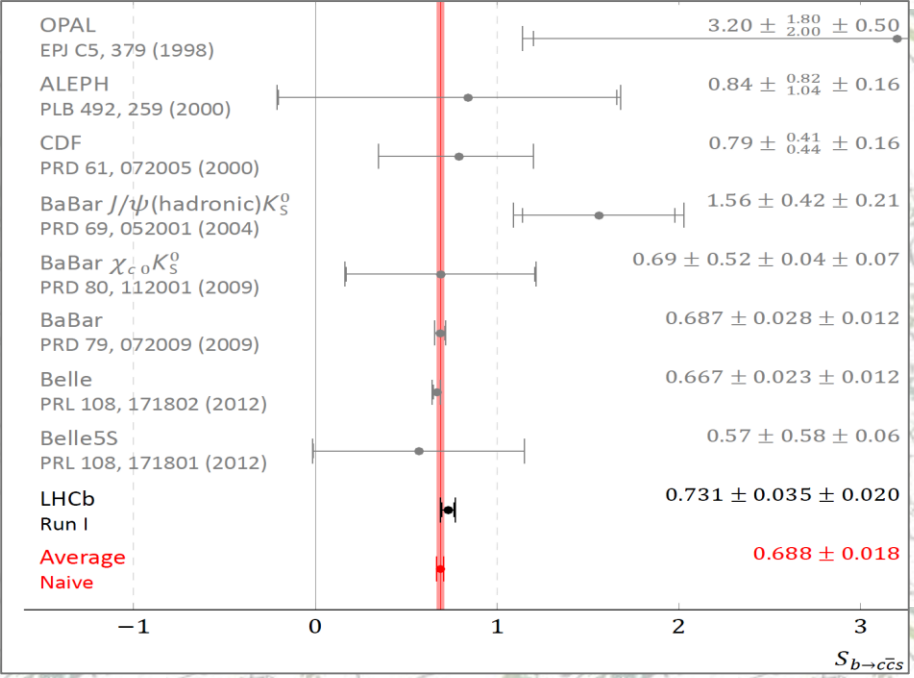
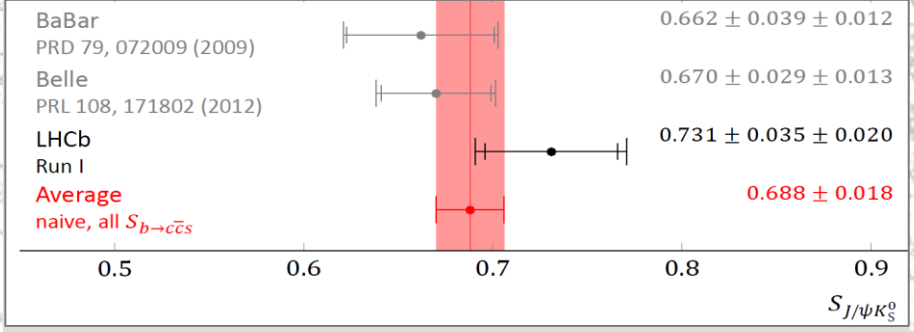



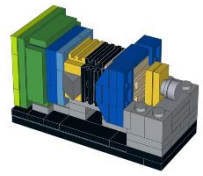

### 3 March 2015: Matter-antimatter trigonometry with LHCb.

#### Precise measurement of the unitarity triangle angle $\beta$ .

Today at [Les Rencontres de Physique de la Vallée d'Aoste](#), La Thuile, Italy, the LHCb collaboration presented an important result in our quest to understand the nature and origin of CP violation, which is a difference in behaviour between matter and antimatter. The result, derived from a careful analysis of the full run 1 data sample, is a measurement of the angle  $\beta$  of the 'unitarity triangle'. This triangle is a geometrical representation of CP violating and associated parameters in the Standard Model. One side is defined to have unit length, the other two sides and three angles can be measured independently in different decays of beauty hadrons. It is the task of experimental physicists to measure these properties and see if they provide a consistent description of the triangle. Any discrepancy would point to signs of New Physics beyond the Standard Model. LHCb has already performed the world's most precise measurements of  $\gamma$ , one of the other triangle angles, see [11 September 2014 news](#), and the mixing frequency of  $B_s$  mesons, see [7 November 2012 news](#), which is an essential ingredient for the determination of the side opposite to the angle  $\gamma$ .

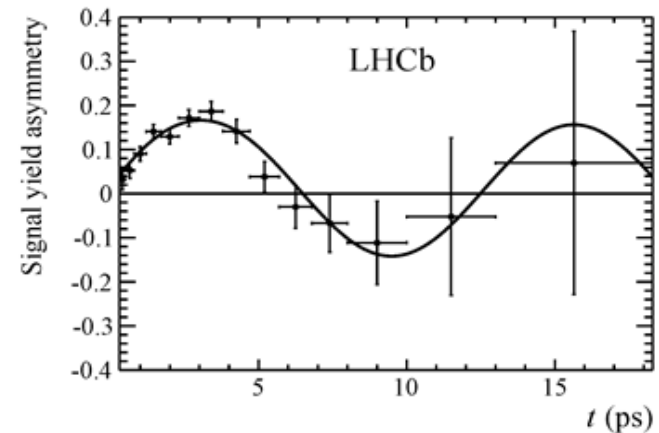
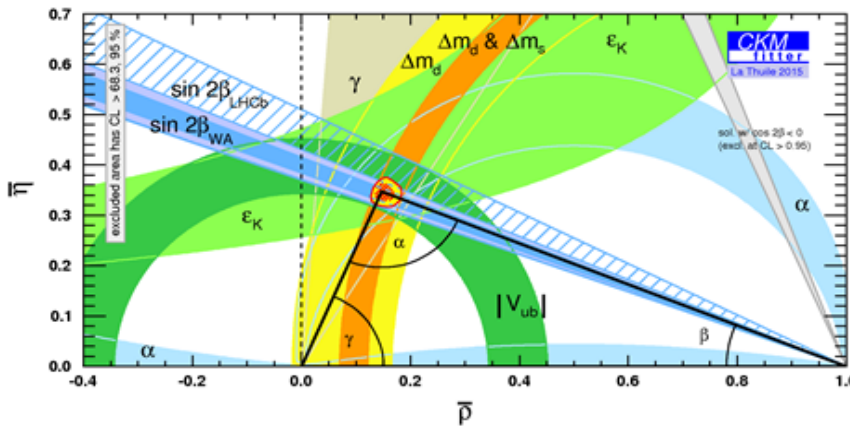



# Next: Moriond EW

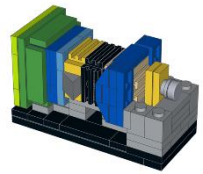

## Angular analysis of $B^0 \rightarrow K^{*0} \mu^+ \mu^-$ with $3\text{fb}^{-1}$

LHCb-PAPER-2013-037, PRL 111(2013) 191801

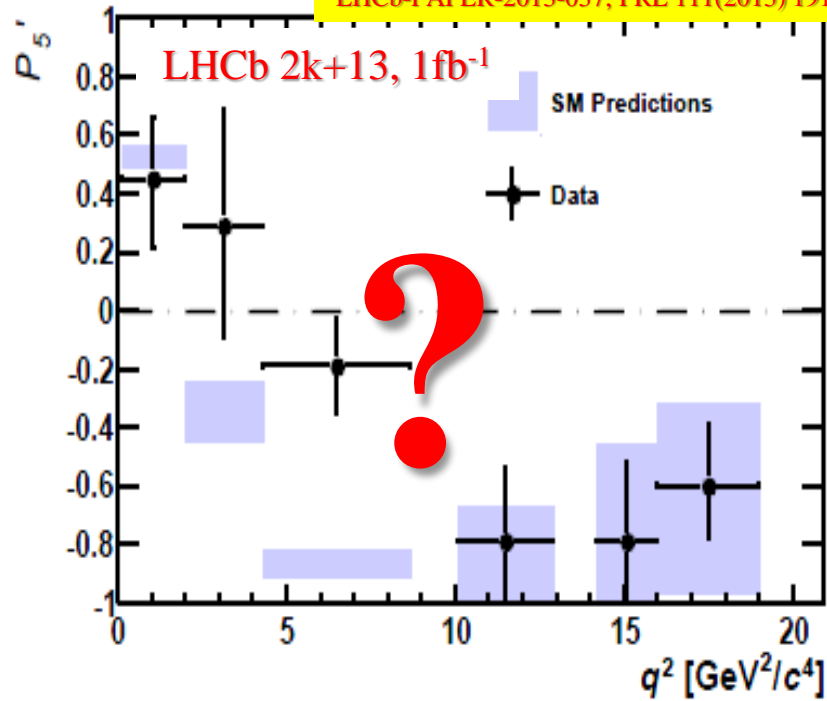

## Precise measurement of $|V_{ub}|$ using $\Lambda_b \rightarrow p \mu^- \nu$

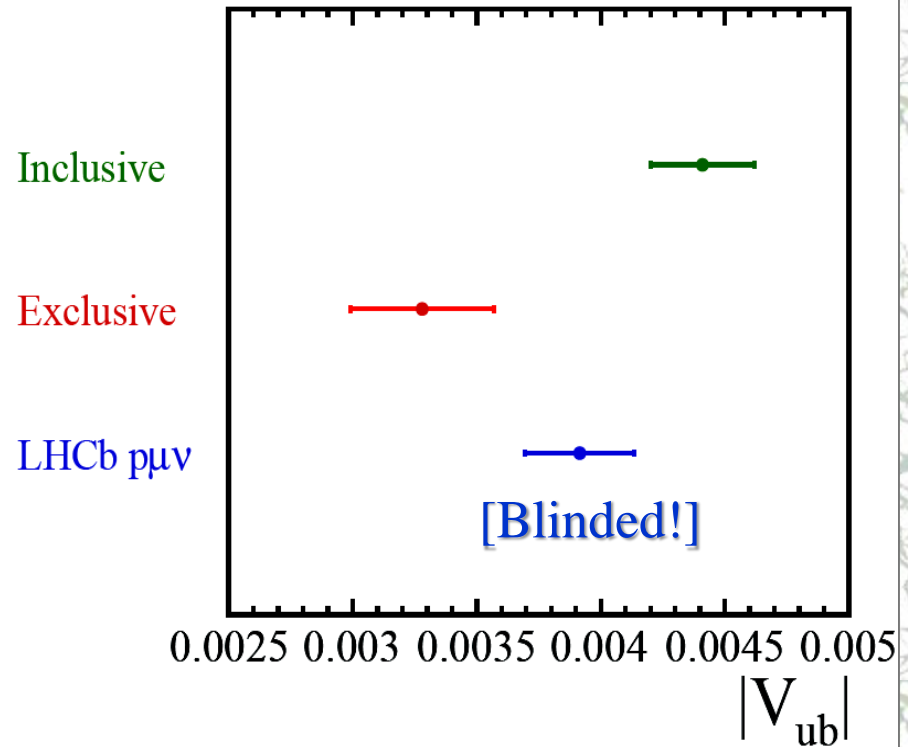





# Preparation to Run II: LS1

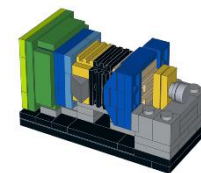

- Muon: HV, groundings, ....
- Hcal: 15% of PMTs are replaced
- Ecal: monitoring fibers are replaced
- OT: repair modules in situ
- Rich: HPD exchange
- Consolidation of cooling, gas, power, shielding, ...
- Beam-pipe, new support
- Dipole, mag.field remeasured
- ...

~1350 impacts in total

**LHCb is closed, all LS1 activity is completed**

POINT 8 – New LHCb Building (SCX8) in progress



PROGRESS (in brief)	
June- July 2014 :	Excavation
August 2014 :	Foundations
September 2014 :	Basement & Technical gallery (SX8)
October 2014 :	Metallic structure
November 2014 :	Floors 1 & 2 + Roof
December 2014 :	Envelope & internal stairs
March 2015:	End of Construction

Outreach visitor platform: 31kvisitors during LS1







# Herschel

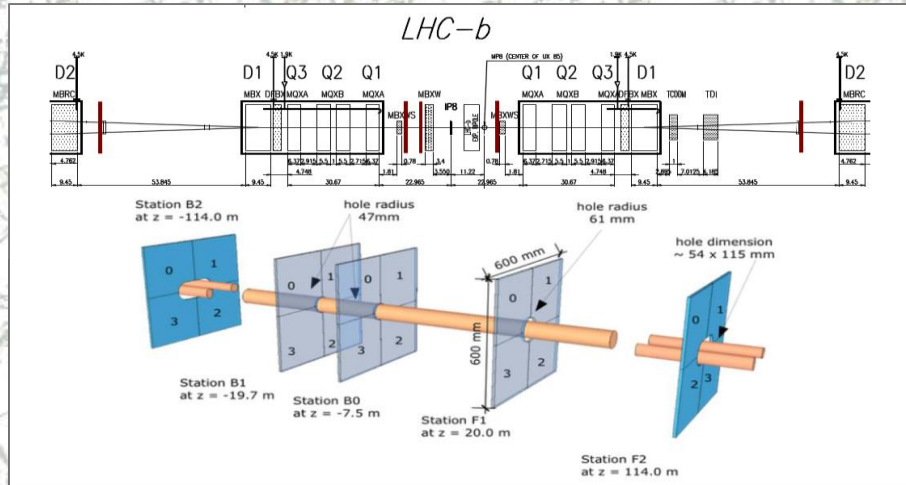
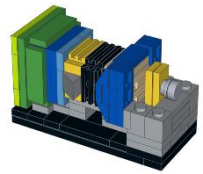

- Scintillating counters with high  $\eta$  coverage
- Important for CEP and diffractive physics

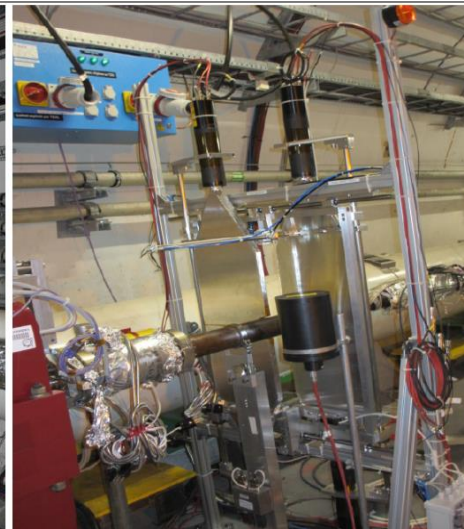
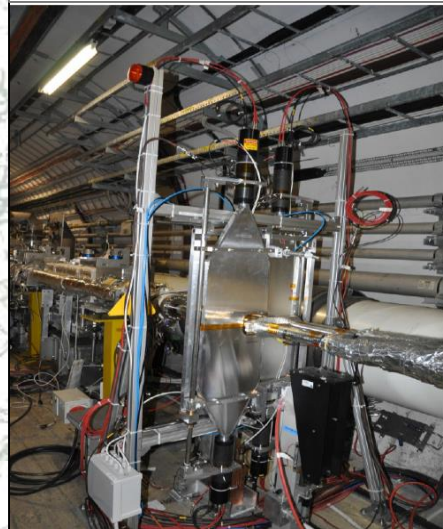

Herschel in the run control:

## Herschel @ November TED

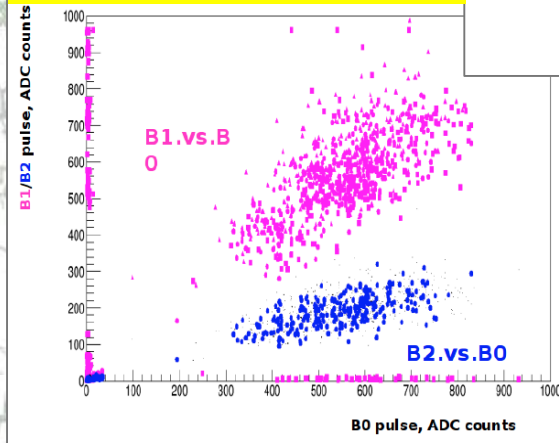



# Commissioning: Cosmics

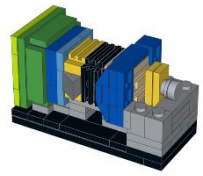

/Calorimeters/CaloEventDisplay

24 February 2015 14:48:06 Online Run 149178

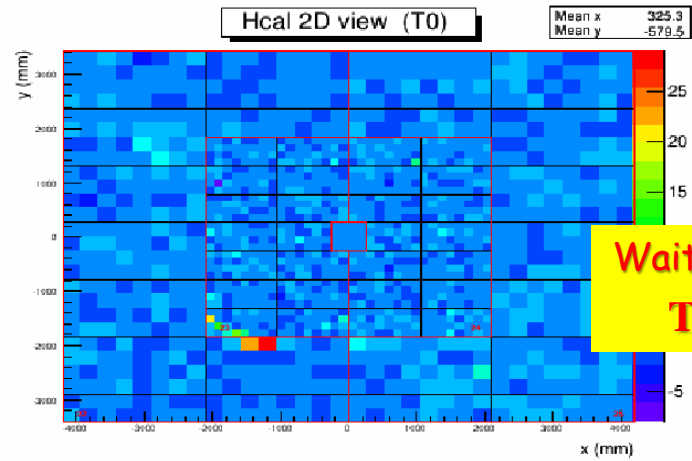
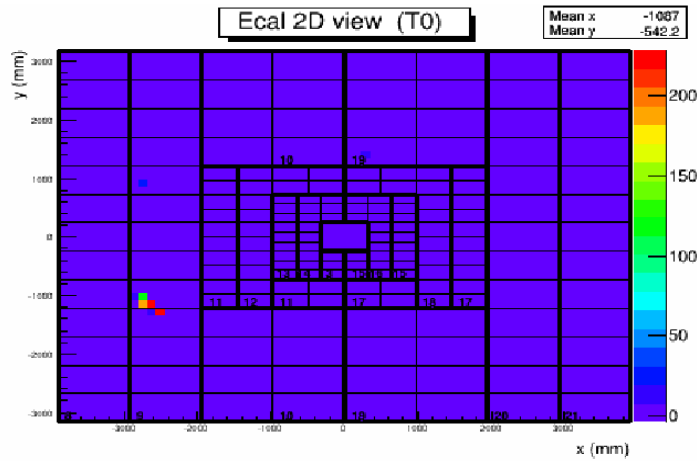
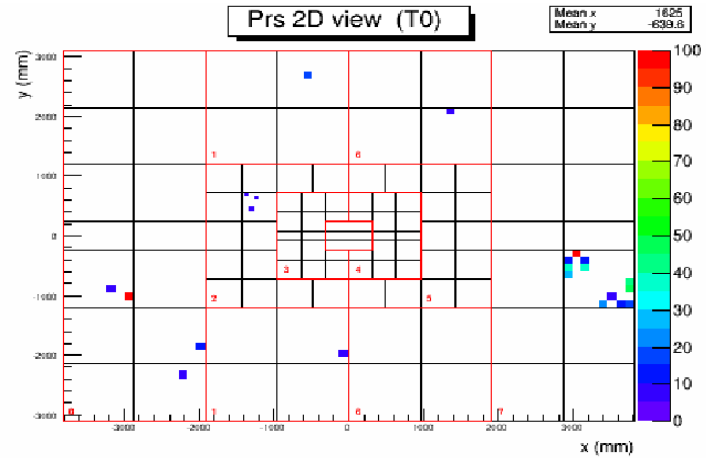
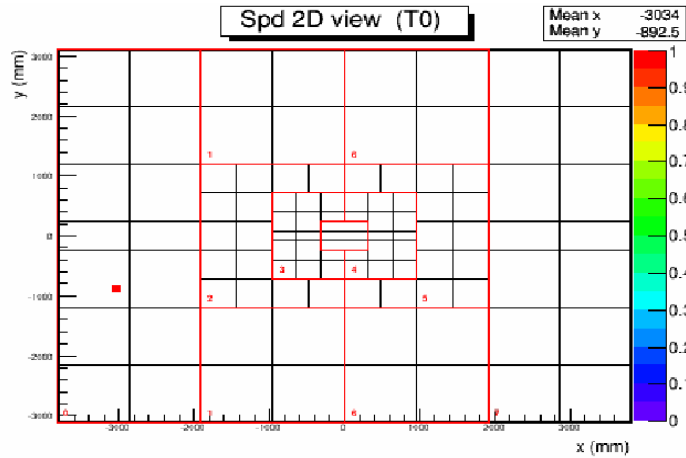

**Waiting for TED shots TOMORROW!**





# Trigger in 2k+15

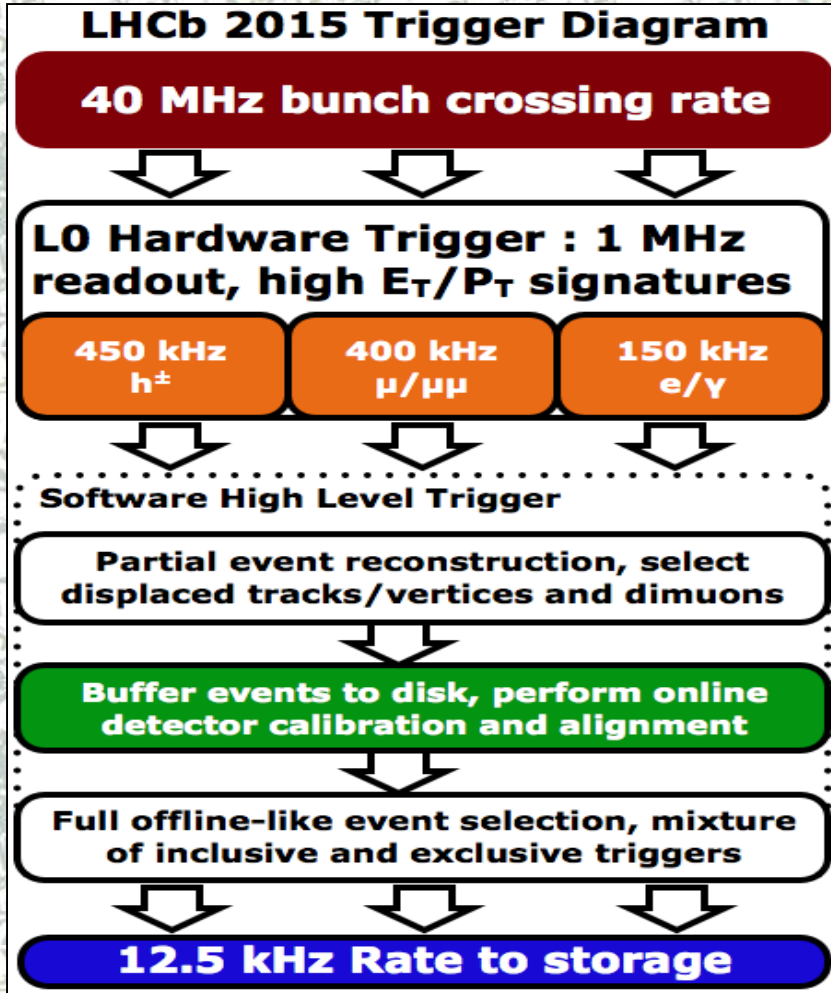
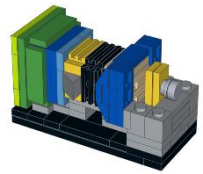

- More powerful
- More robust
- More flexible
- More selective
- More efficient

... just better

New:

- on-line calibration in between Hlt1 and Hlt2
- Off-line quality of data after trigger:
  - Analyses with on-line data "Turbo-stream"



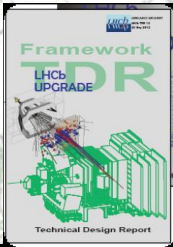

# Next: Upgrade

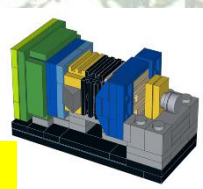

LHCb is finalizing the R&D in most areas and preparing Engineering Design Reviews, followed by Production Readiness Reviews in the end of the year

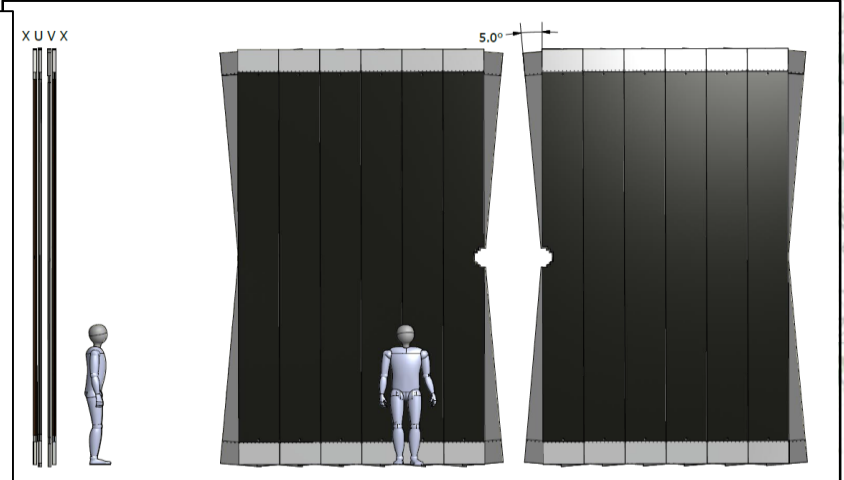
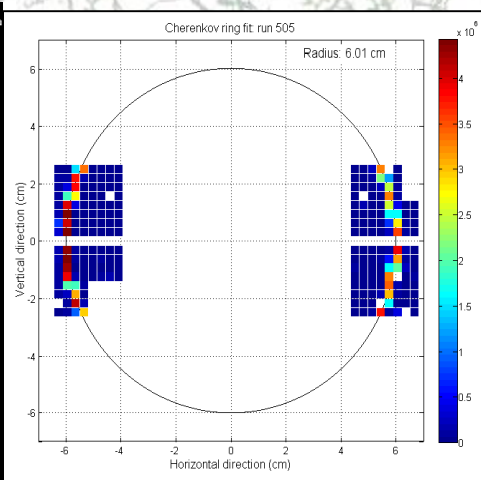
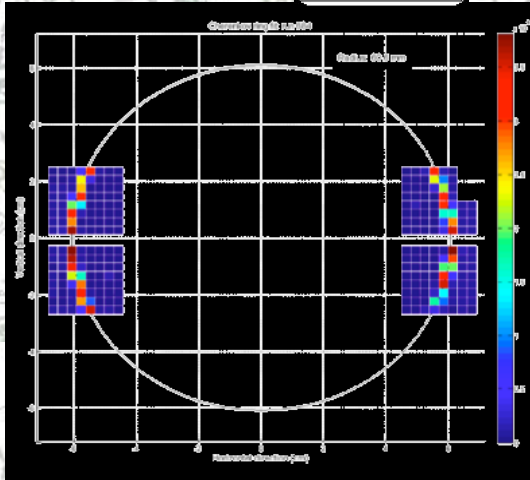

300 m long fibers have been installed in LHCb  
Tests with a full DAQ chain already ongoing



Surface setup



Cavern setup

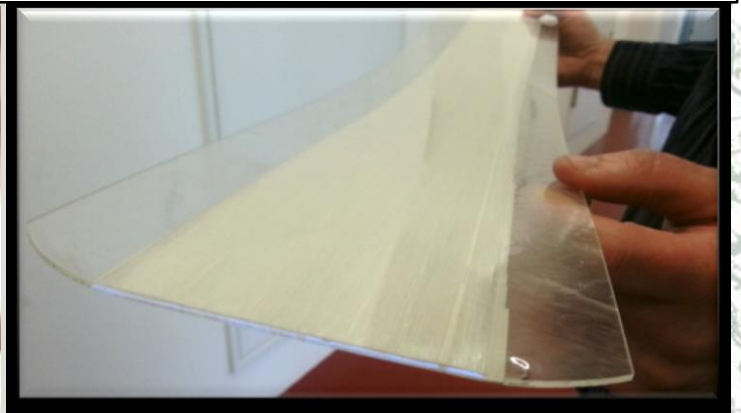
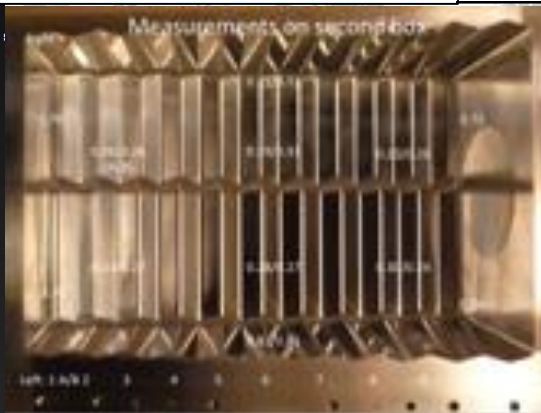

A list of milestones is closely monitored by the LHCC: the already tight schedule does not allow for much margin



# Upgrade: the target

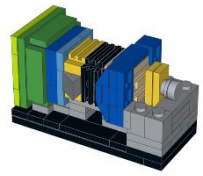

Type	Observable	LHC Run 1	LHCb 2018	<b>LHCb upgrade</b>	Theory
$B_s^0$ mixing	$\phi_s(B_s^0 \rightarrow J/\psi \phi)$ (rad)	0.049	0.025	<b>0.009</b>	$\sim 0.003$
	$\phi_s(B_s^0 \rightarrow J/\psi f_0(980))$ (rad)	0.068	0.035	<b>0.012</b>	$\sim 0.01$
	$A_{sl}(B_s^0)$ ( $10^{-3}$ )	2.8	1.4	<b>0.5</b>	0.03
Gluonic penguin	$\phi_s^{\text{eff}}(B_s^0 \rightarrow \phi\phi)$ (rad)	0.15	0.10	<b>0.018</b>	0.02
	$\phi_s^{\text{eff}}(B_s^0 \rightarrow K^{*0}\bar{K}^{*0})$ (rad)	0.19	0.13	<b>0.023</b>	$< 0.02$
	$2\beta^{\text{eff}}(B^0 \rightarrow \phi K_S^0)$ (rad)	0.30	0.20	<b>0.036</b>	0.02
Right-handed currents	$\phi_s^{\text{eff}}(B_s^0 \rightarrow \phi\gamma)$ (rad)	0.20	0.13	<b>0.025</b>	$< 0.01$
	$\tau^{\text{eff}}(B_s^0 \rightarrow \phi\gamma)/\tau_{B_s^0}$	5%	3.2%	<b>0.6%</b>	0.2%
Electroweak penguin	$S_3(B^0 \rightarrow K^{*0}\mu^+\mu^-; 1 < q^2 < 6 \text{ GeV}^2/c^4)$	0.04	0.020	<b>0.007</b>	0.02
	$q_0^2 A_{\text{FB}}(B^0 \rightarrow K^{*0}\mu^+\mu^-)$	10%	5%	<b>1.9%</b>	$\sim 7\%$
	$A_{\Gamma}(K\mu^+\mu^-; 1 < q^2 < 6 \text{ GeV}^2/c^4)$	0.09	0.05	<b>0.017</b>	$\sim 0.02$
	$\mathcal{B}(B^+ \rightarrow \pi^+\mu^+\mu^-)/\mathcal{B}(B^+ \rightarrow K^+\mu^+\mu^-)$	14%	7%	<b>2.4%</b>	$\sim 10\%$
Higgs penguin	$\mathcal{B}(B_s^0 \rightarrow \mu^+\mu^-)$ ( $10^{-9}$ )	1.0	0.5	<b>0.19</b>	0.3
	$\mathcal{B}(B^0 \rightarrow \mu^+\mu^-)/\mathcal{B}(B_s^0 \rightarrow \mu^+\mu^-)$	220%	110%	<b>40%</b>	$\sim 5\%$
Unitarity triangle angles	$\gamma(B \rightarrow D^{(*)}K^{(*)})$	$7^\circ$	$4^\circ$	<b><math>0.9^\circ</math></b>	negligible
	$\gamma(B_s^0 \rightarrow D_s^\mp K^\pm)$	$17^\circ$	$11^\circ$	<b><math>2.0^\circ</math></b>	negligible
	$\beta(B^0 \rightarrow J/\psi K_S^0)$	$1.7^\circ$	$0.8^\circ$	<b><math>0.31^\circ</math></b>	negligible
Charm	$A_{\Gamma}(D^0 \rightarrow K^+K^-)$ ( $10^{-4}$ )	3.4	2.2	<b>0.4</b>	–
$CP$ violation	$\Delta A_{CP}$ ( $10^{-3}$ )	0.8	0.5	<b>0.1</b>	–



# Summary

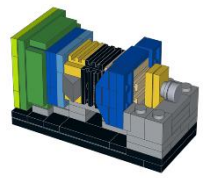

- LHCb continues analysis of Run I results:
  - 241 papers, 6 new results this week, some new results are prepared for *incoming conferences*
  - Most results are in agreement with Standard Model
    - There is room for improvement both with statistics and systematic
- LHCb is ready for Run II
  - Closed; TED shots tomorrow
- LHCb is preparing for long future (Upgrade)

Stay tuned!





# LHCb @ Student's poster session

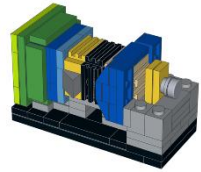

**ELECTROWEAK PHYSICS IN THE FORWARD REGION**

**Measurement of the semileptonic CP asymmetry in  $B^0 \rightarrow D^0$  mixing**

**CP violating phase  $\phi_2$  and penguin pollution in  $B_c^0 \rightarrow J/\psi K^+ K^-$**

**Angular analysis of  $B^0 \rightarrow K^+ K^- e^+ e^-$  in the low- $q^2$  region**

**CKM angle  $\gamma$  from LHCb**

**Search for CP violation in  $D^0 \rightarrow \pi^+ \pi^- \pi^0$  decays with the energy test**

**FIRST OBSERVATION AND MEASUREMENT OF THE BRANCHING FRACTION FOR THE DECAY  $B_c^0 \rightarrow D^+ K^-$**

**Do not miss the excellent opportunity to talk with young LHCb students: 17:00, extension rest. 1**

**$\Lambda_c \rightarrow \Lambda^0 \mu^+ \mu^-$  branching ratio and angular analysis**

**Production and evolution of  $B_c^0$  mesons**

**Search for CP violation in  $D^0 \rightarrow \pi^+ \pi^- \pi^0$  decays with the energy test**

**Alignment of the tracking system**

**Event selection and analysis**

**Search for CP violation in  $D^0 \rightarrow \pi^+ \pi^- \pi^0$  decays with the energy test**

**Alignment of the tracking system**

**Event selection and analysis**

**Search for CP violation in  $D^0 \rightarrow \pi^+ \pi^- \pi^0$  decays with the energy test**

**Alignment of the tracking system**

**Event selection and analysis**





# LHCb @ Student's poster session

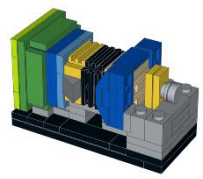

*Electroweak physics in forward region at LHCb*

*Measurement of the semileptonic CP asymmetry in  $B^0\bar{B}^0$  mixing with LHCb*

*CP violating phase  $\phi_s$  and penguin pollution in  $B_s \rightarrow J/\psi K^+ K^-$  with LHCb*

*Production asymmetries of neutral B mesons in pp collisions*

*Angular analysis of the  $B^0 \rightarrow K^{*0} e^+ e^-$  decay in the low- $q^2$  region at LHCb*

*CKM angle  $\gamma$  at LHCb*

*Search for CP violation in  $D^0 \rightarrow \pi^+ \pi^- \pi^0$  decays with LHCb*

*$\Lambda_b \rightarrow \Lambda^0 \mu^+ \mu^-$  branching fraction and angular analysis*

*Study for the rare  $B_s$  and  $B^0$  decays into the  $\pi^+ \pi^- \mu^+ \mu^-$  final state at LHCb*

*$\sin 2\beta$  with  $B^0 \rightarrow J/\psi K_S$  at the LHCb experiment*

*LHCb's Real-time alignment in Run II*

*Topological Trigger developments at LHCb*

*Flavour tagging with the LHCb experiment*