

# The layout and expected cleaning for the first crystal-assisted collimation experiment at the LHC

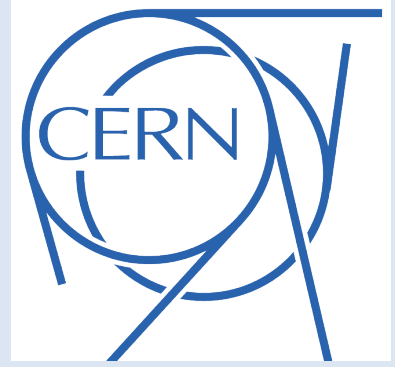

cern.ch/UA9

W. Scandale, LAL, Paris, France  
On behalf of UA9 Collaboration

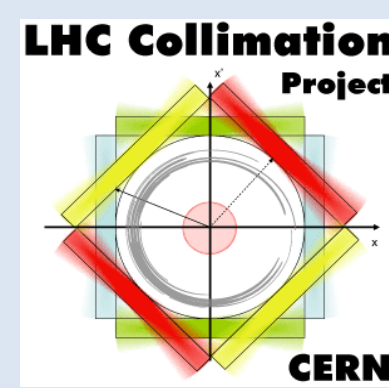

## Abstract

The installation in the CERN Large Hadron Collider (LHC) of two crystals in the horizontal and vertical planes was accomplished during the LHC long shutdown (LS1) for crystal assisted collimation studies. An appropriate layout was designed to demonstrate the principle feasibility of crystal collimation at the LHC. Extensive simulation campaigns were made to evaluate different crystal positions and parameters, and to ensure that the main goals of these first feasibility tests in the LHC are reachable. The final layout is presented. An overview of the considerations behind the design choices and the crystal parameters is given, and the expected performance of the system is discussed.

## The Crystal Collimation CONCEPT

### The Present Collimation of LHC

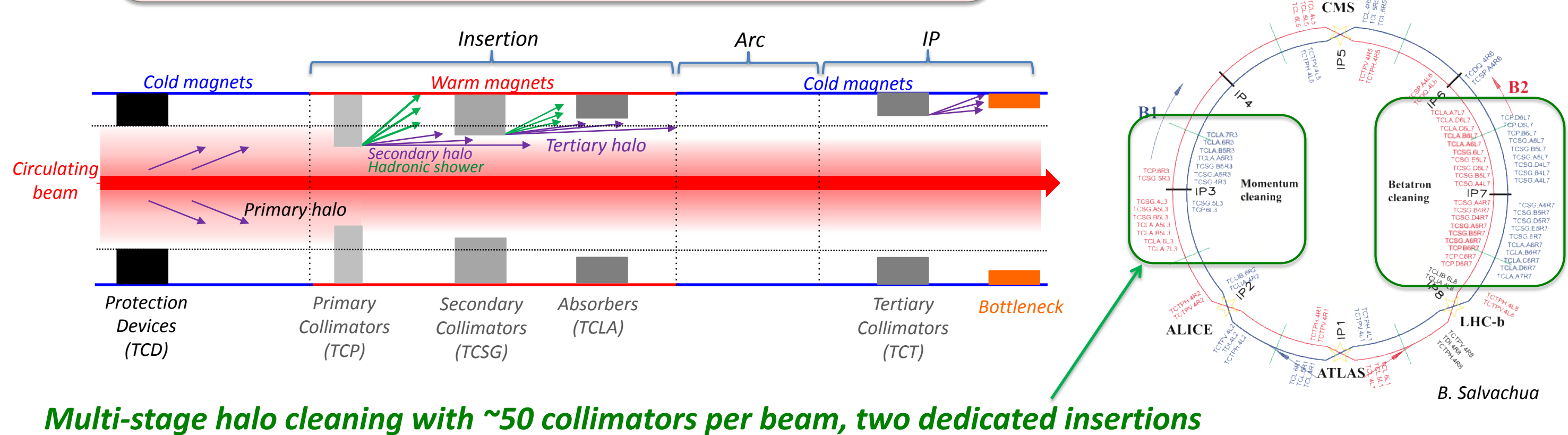

### The Crystal Assisted Collimation of LHC

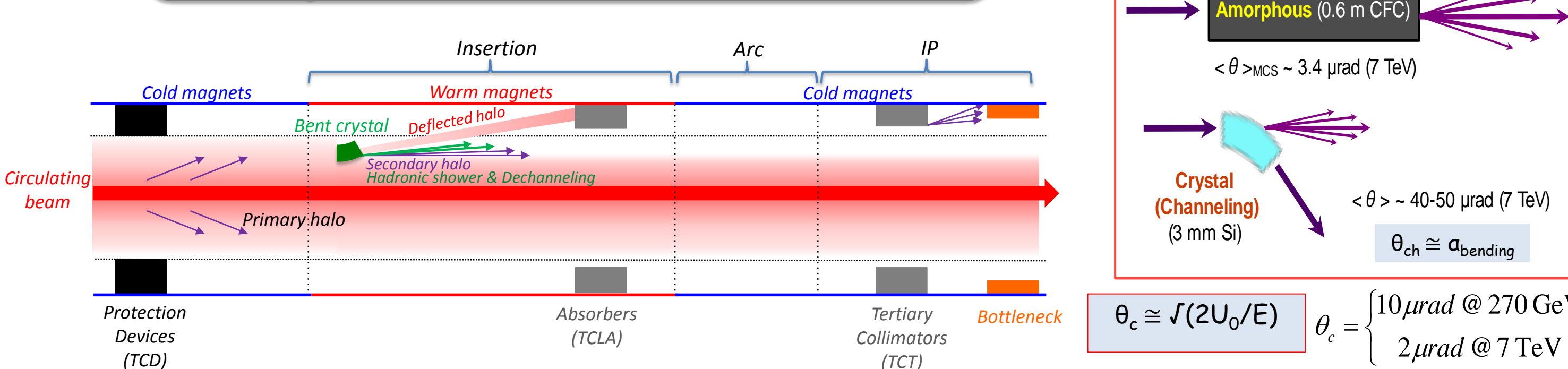

Crystals deflect particles by coherent interaction:

- ✓ large angle deflection also at high energy
- ✓ reduced interaction probability (e.g. diffractive events, ion fragmentation/dissociation)
- ✓ reduced impedance (less secondary collimators, larger gaps)

BUT

✗ small angular acceptance  
✗ concentration of the losses on a single absorber  
✗ extrapolation to the highest energy not yet proven

## INTRODUCTION

Principle feasibility of crystal-assisted collimation demonstrated in the last 4 years of tests in the SPS, in the framework of the UA9 Collaboration

Main questions to be addressed before relying on this technology for HL-LHC:

- Can crystal-assisted collimation improve the present, already very good, cleaning system?
- Can crystal-assisted collimation ensure stable performance in any machine configuration?
- Is crystal collimation compatible with safe operations in any beam condition?
- Do crystal properties, observed so far at lower beam energies, scale to the LHC energy as expected?

- To address these items and compare the predictions of expected cleaning performance with respect to what is achieved with the present system.
- First tests in the LHC are foreseen after the machine commissioning in 2015, during dedicated low-intensity Machine Development runs.

## The LAYOUT of EXPERIMENT at the SPS

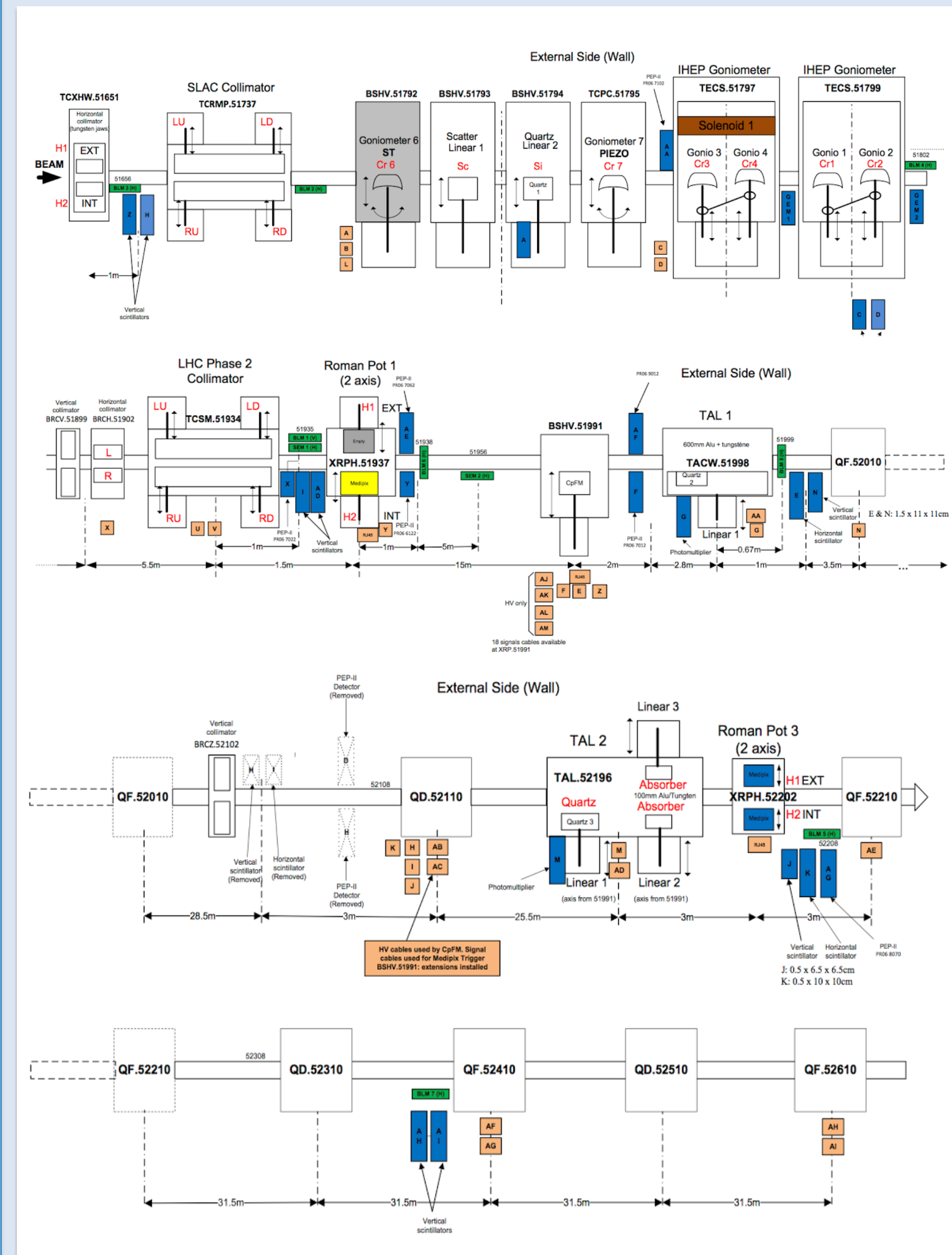

### Important Results

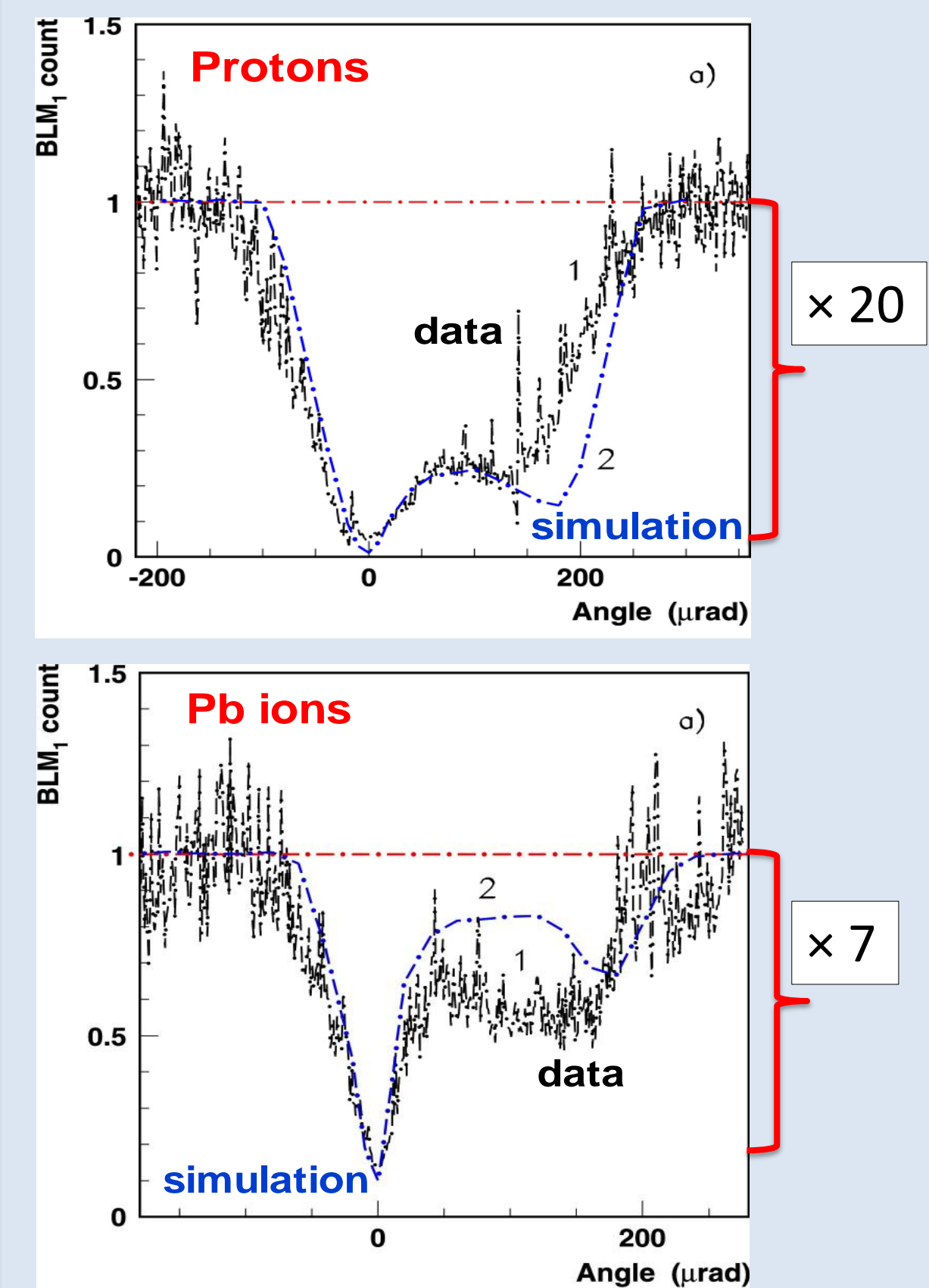

Loss Rate Reduction at the Channeling vs. Amorphous

## GONIOMETERS and CRYSTALS

- Layout optimized to have a minimum impact on the present system, and to ensure tests in any machine configuration.
- Only two goniometers are installed in the H&V planes of the LHC Beam 1.
- An accuracy of 1 μrad is achieved using a mixed piezo-mechanic technology, to orient the crystals on the beam envelope.
- Existing collimators are used to absorb the extracted halo particles.

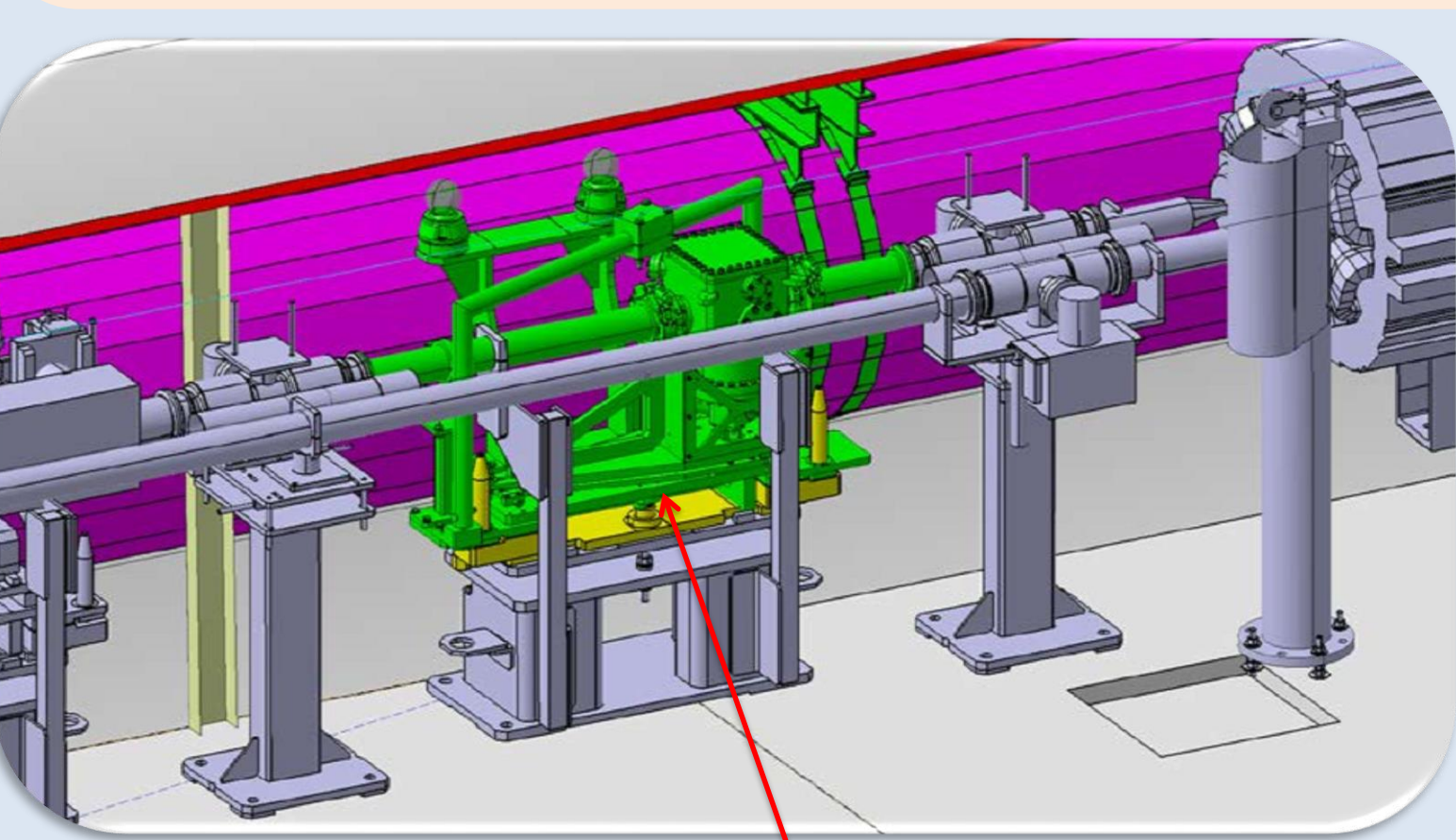

### Crystals

horizontal vertical

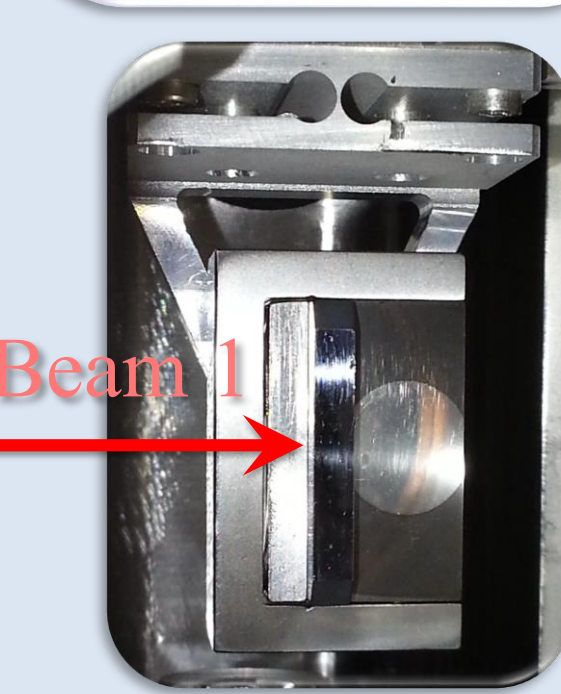
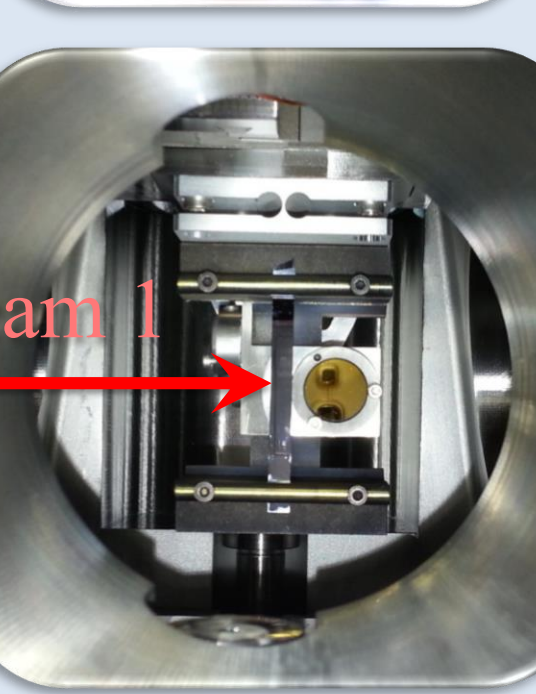
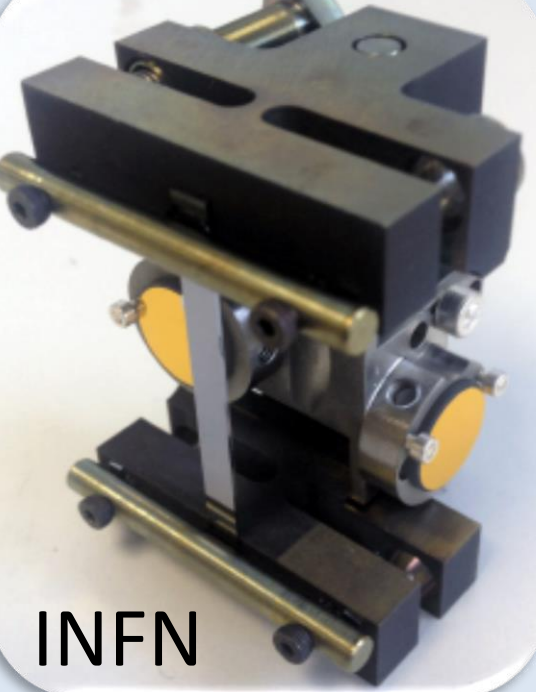

| Collimation plane | Bending [μrad] | Length [mm] | Material | Bending planes |
|-------------------|----------------|-------------|----------|----------------|
| Hor.              | ~50            | 4           | Si       | 110            |
| Ver.              | ~50            | 4           | Si       | 111            |

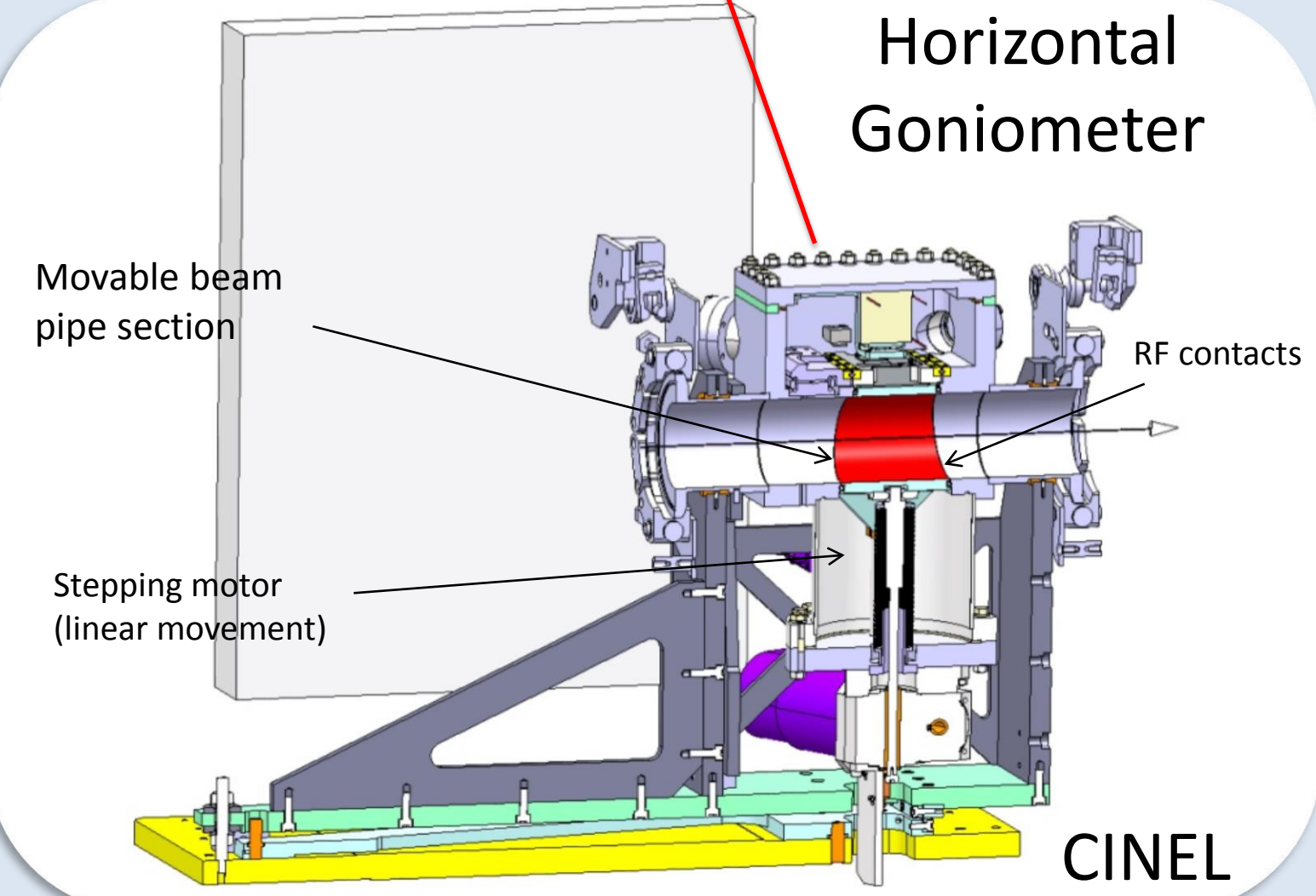

## The LAYOUT of EXPERIMENT at the LHC

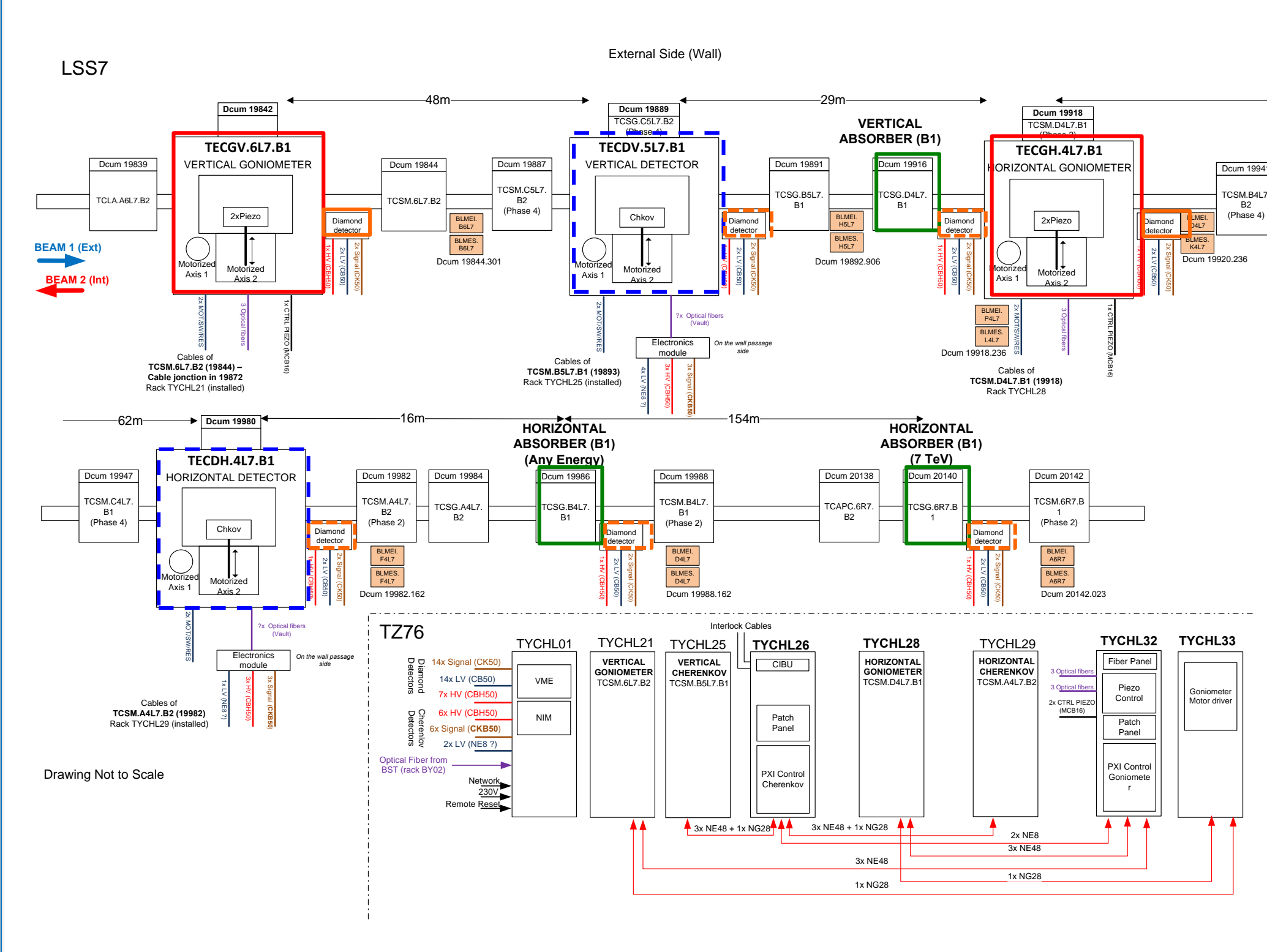

- 2 goniometers with crystals
  - ✓ Cables from phase-2 collimators + new optical fibers
  - ✓ 1 new support, 1 support from phase-2 collimator
- 3 absorbers (TCSGs – already installed)
- 2 Cherenkov detectors (not for installation during LS1)
  - ✓ 2 new supports
  - ✓ New signal and HV cables
  - ✓ New vacuum system cables
- 7 diamond BLMs (2 for installation during LS1)
  - ✓ New cables
- Control electronics to be installed in TZ76

### Standard Collimation

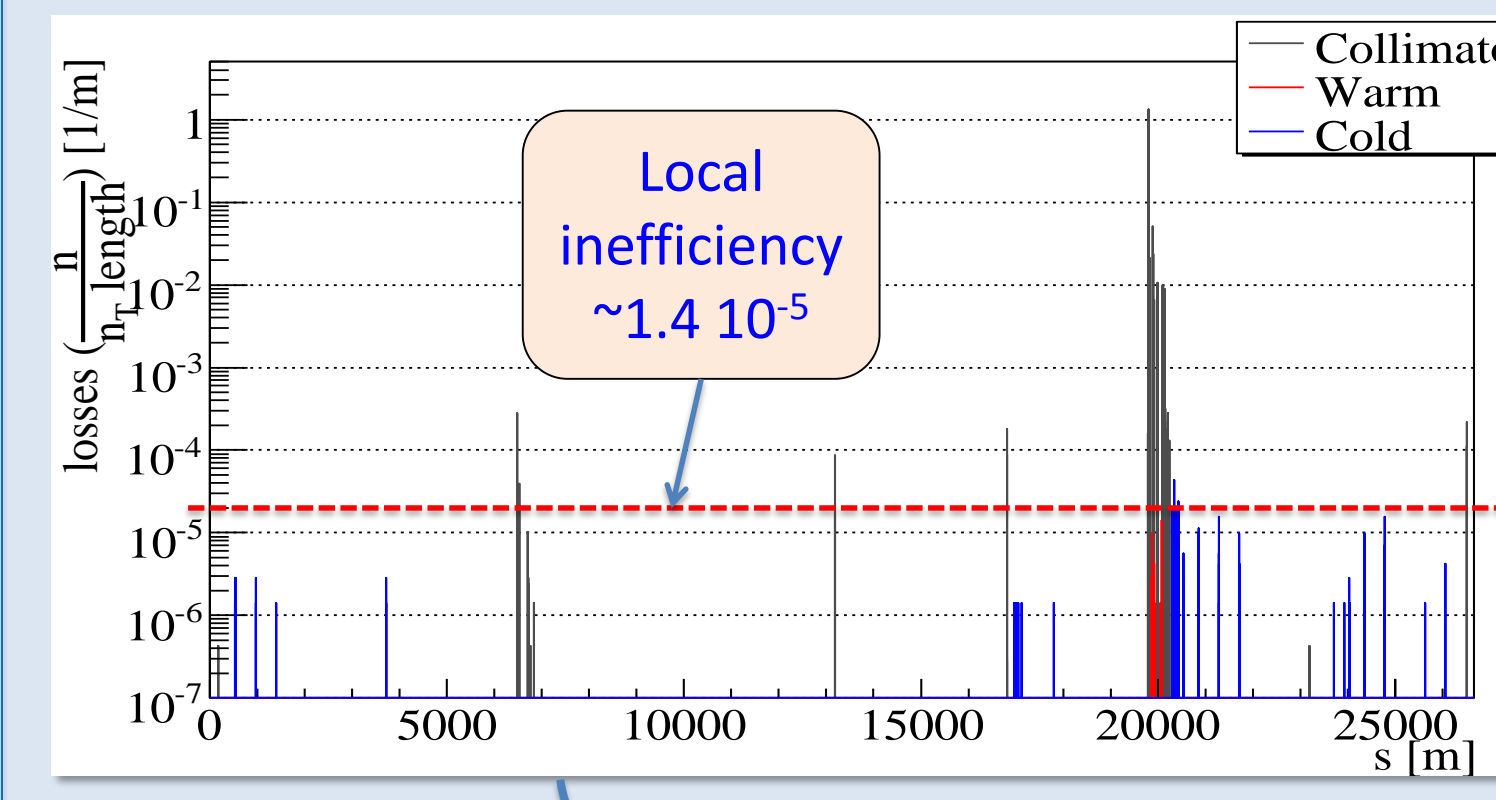

### Crystal Collimation

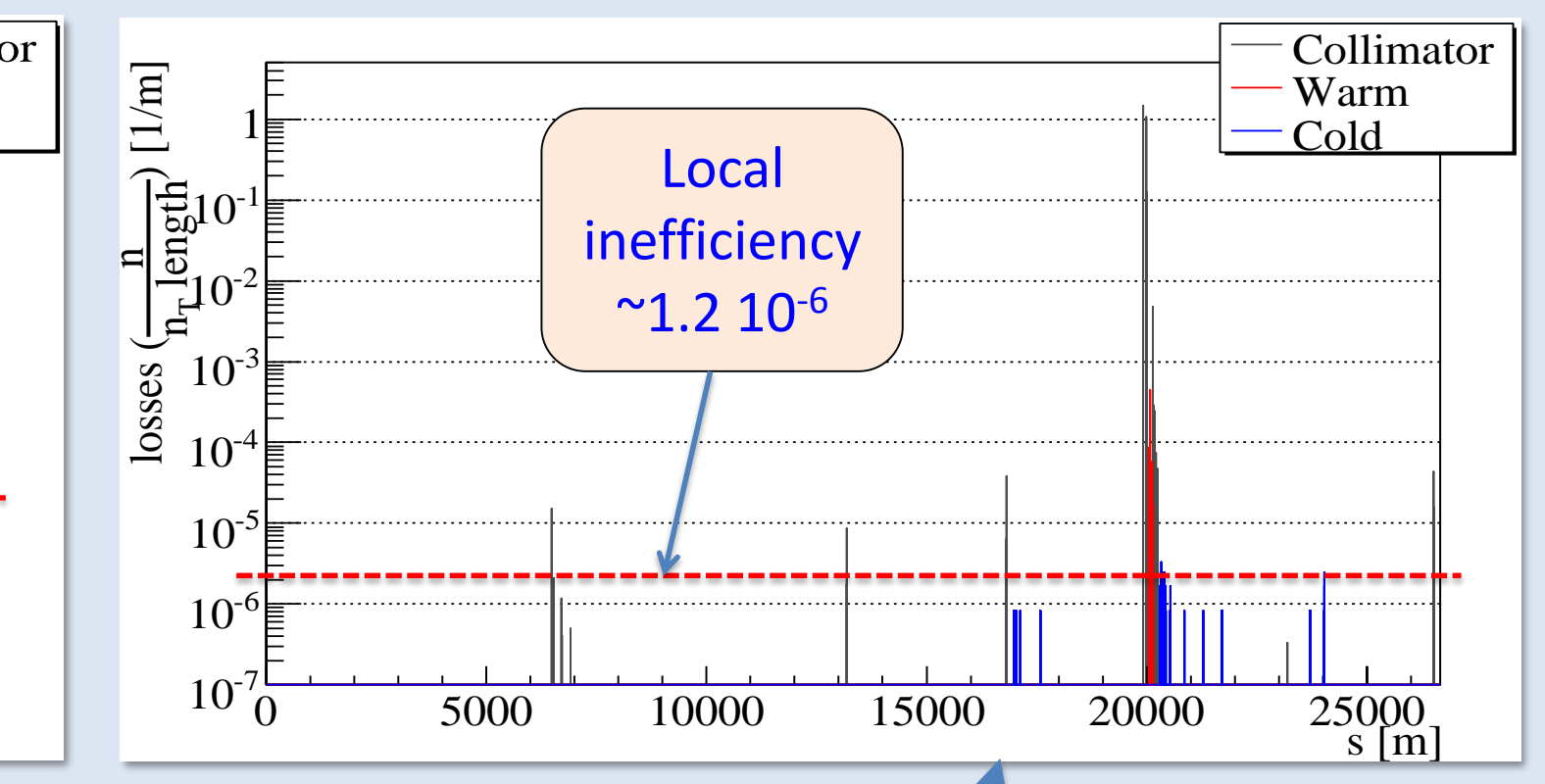

Simulated leakage of Halo Particles reduced by factor ~12

## CONCLUSIONS

An overview of the final layouts for first crystal-assisted collimation tests in the LHC, with expected performance and preparatory studies was given. Crystal bending and length were optimized to ensure tests in any machine configuration and provide  $R > 4R_c$ .

Based on these promising results that show a better performance of the crystal-based collimation, we are confident that the proposed layout can ensure a successful set of tests for beam energies ranging from injection to top energy, in both planes, both with ions and protons beam.