

# RHIC Experiments in Transition at Brookhaven National Laboratory

**Outline:** • Today to 2022

Edouard Kistenev  
Brookhaven National Laboratory  
PHENIX Experiment



# Brookhaven National Laboratory in Transition

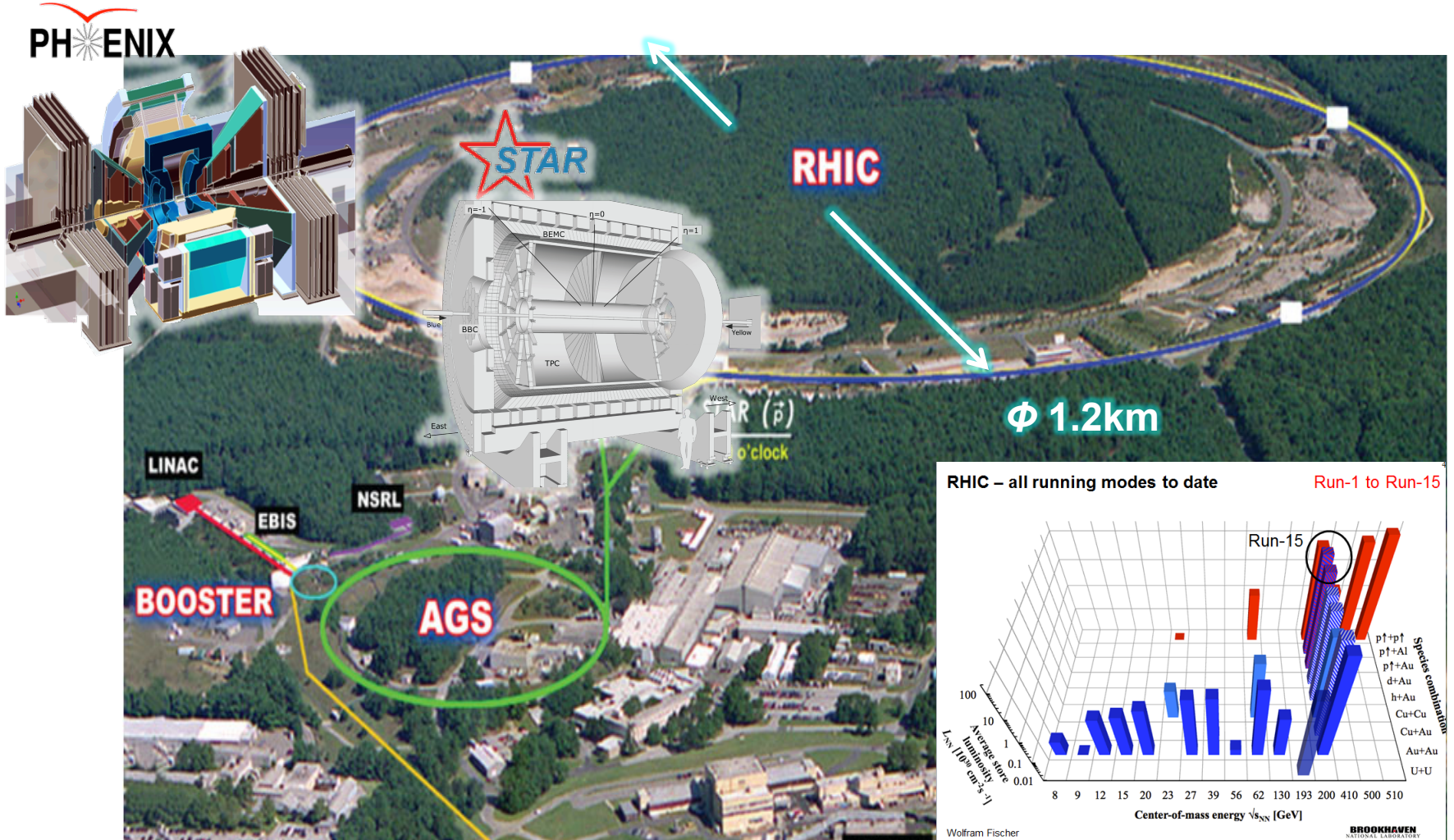


January 18, 2016

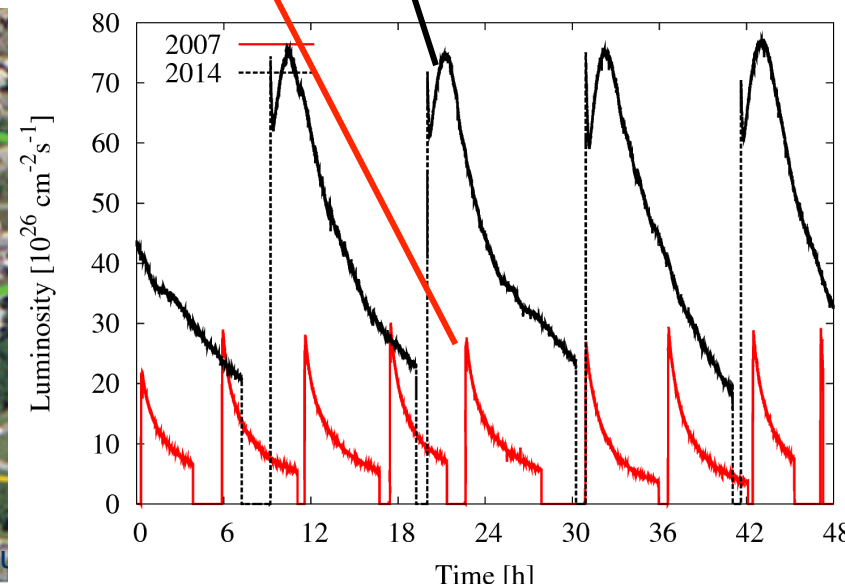
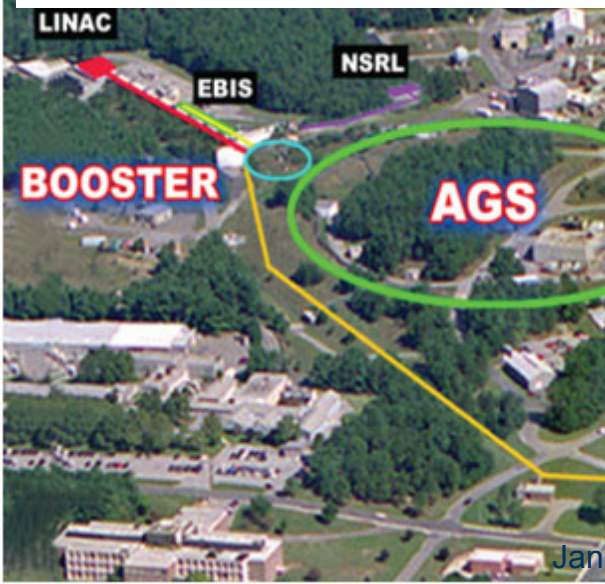
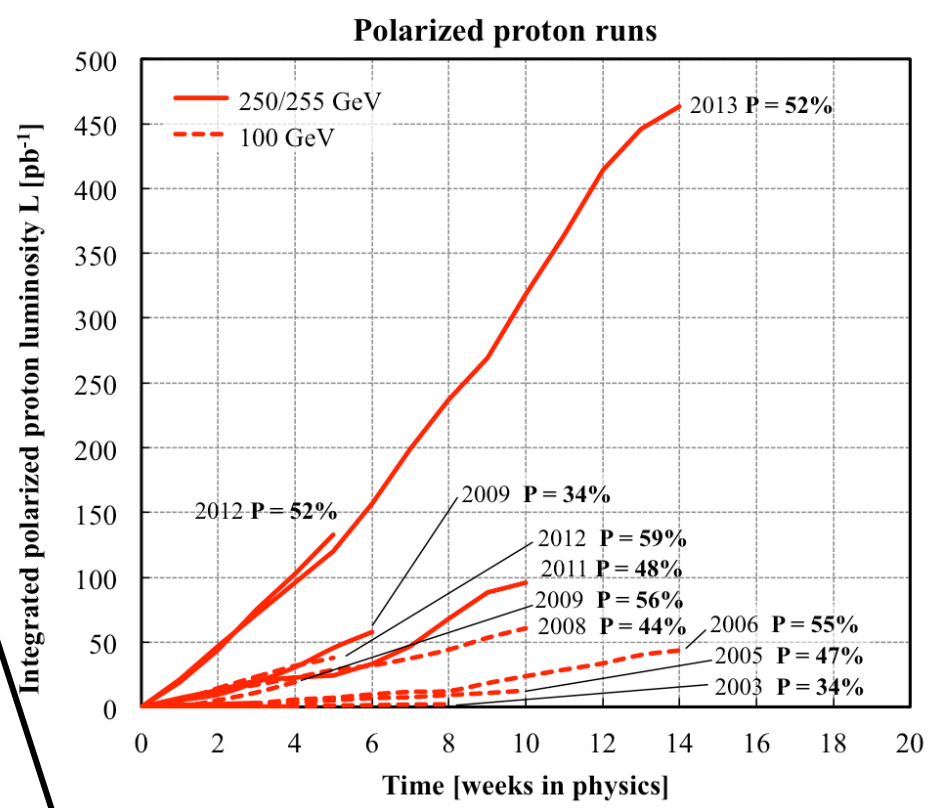
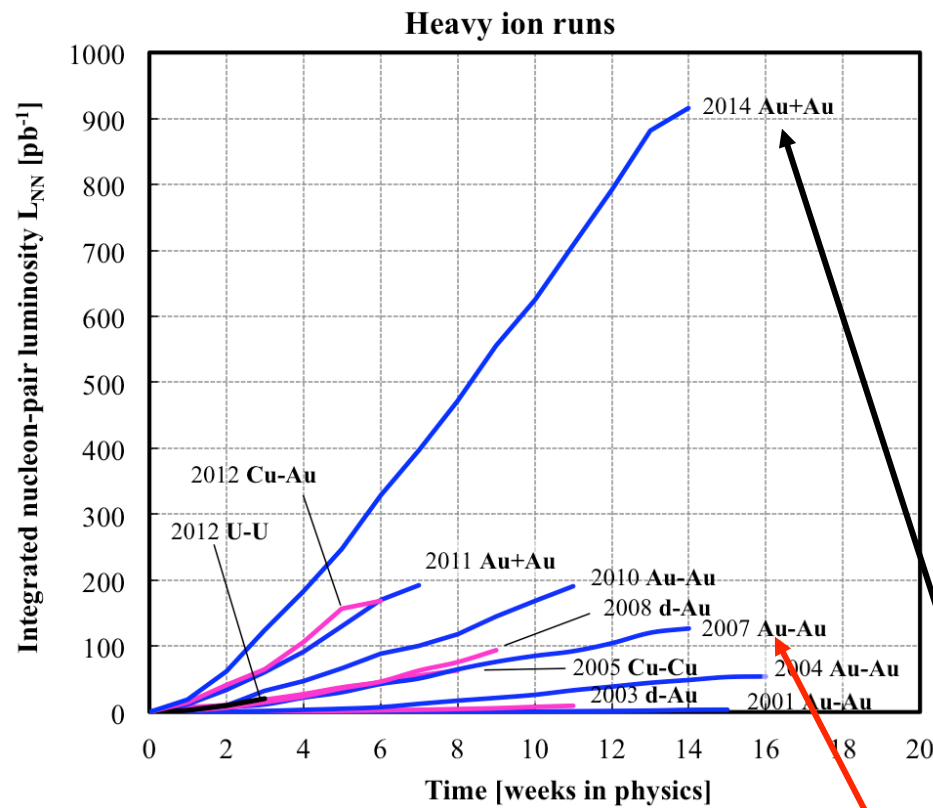
E.Kistenev, UTFSM, 2016



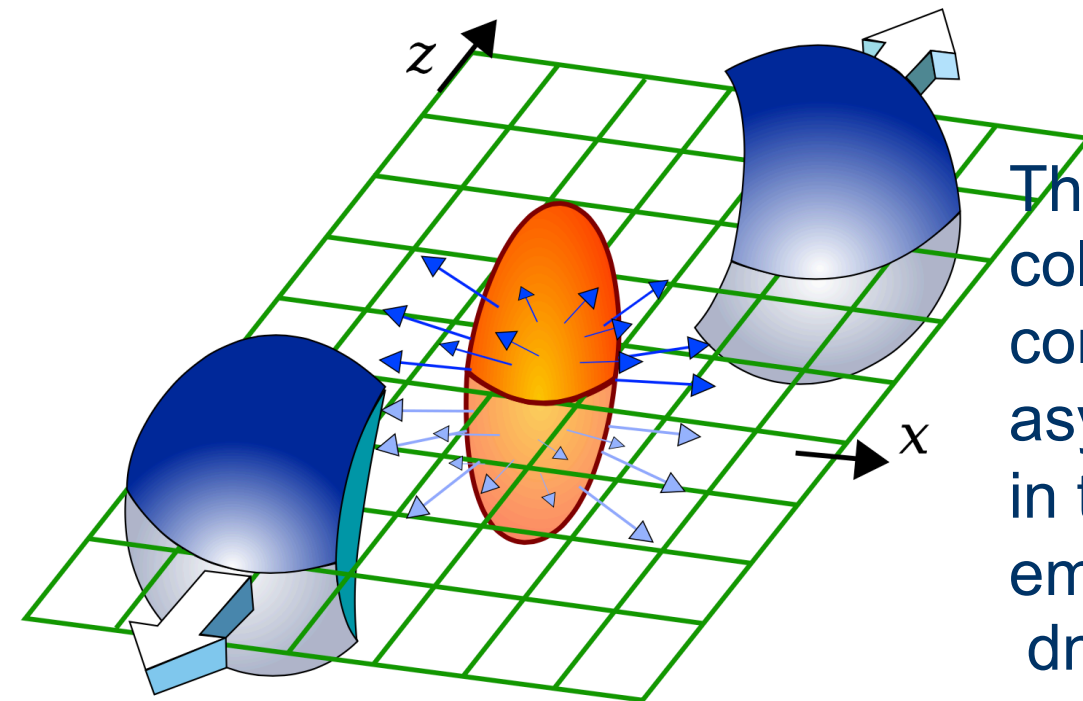
# Relativistic Heavy Ion Collider Bird's eye view











The collective nature of the the collision created medium converts **initial state** azimuthal asymmetry into a **strong** signal in the **final state** particle emission pattern

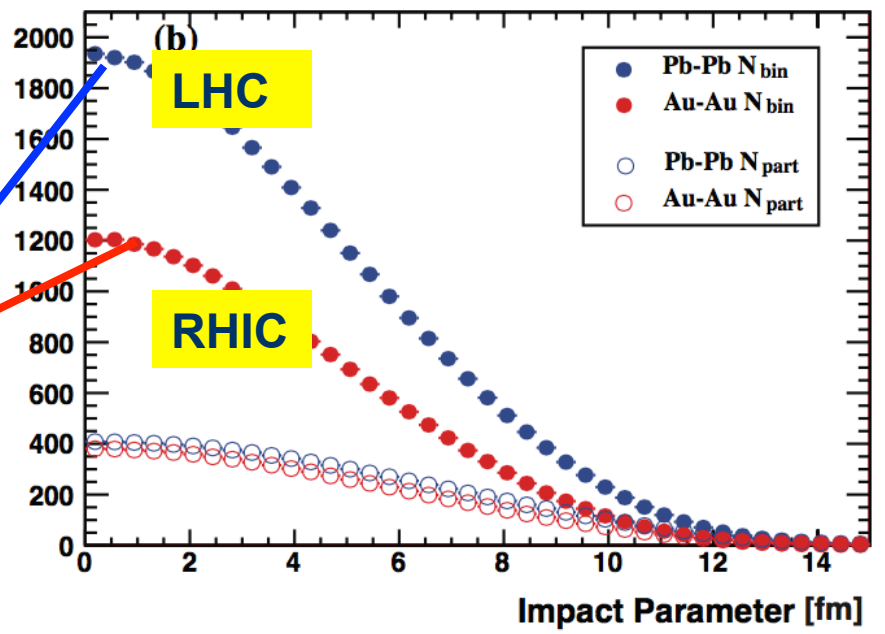
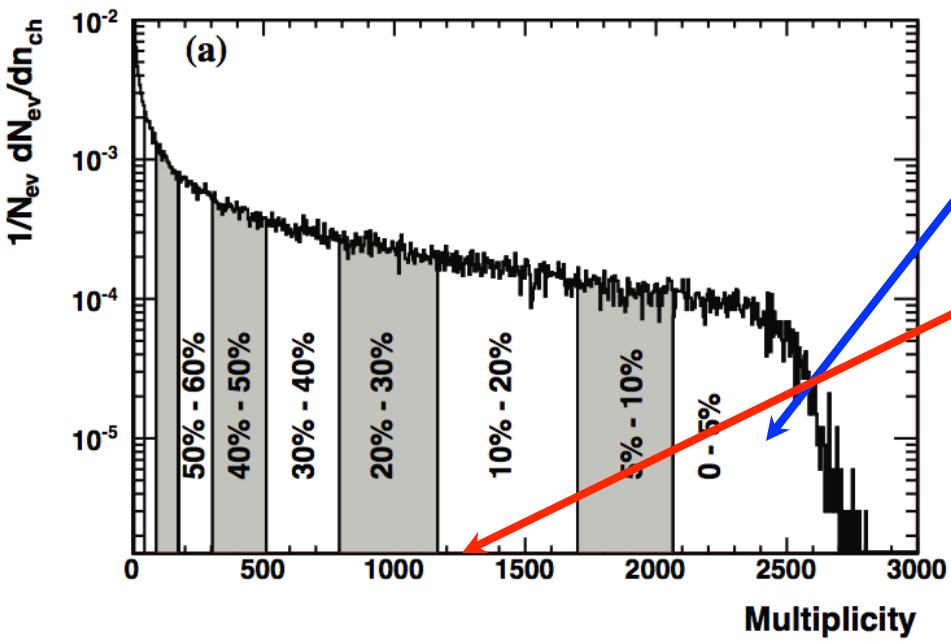
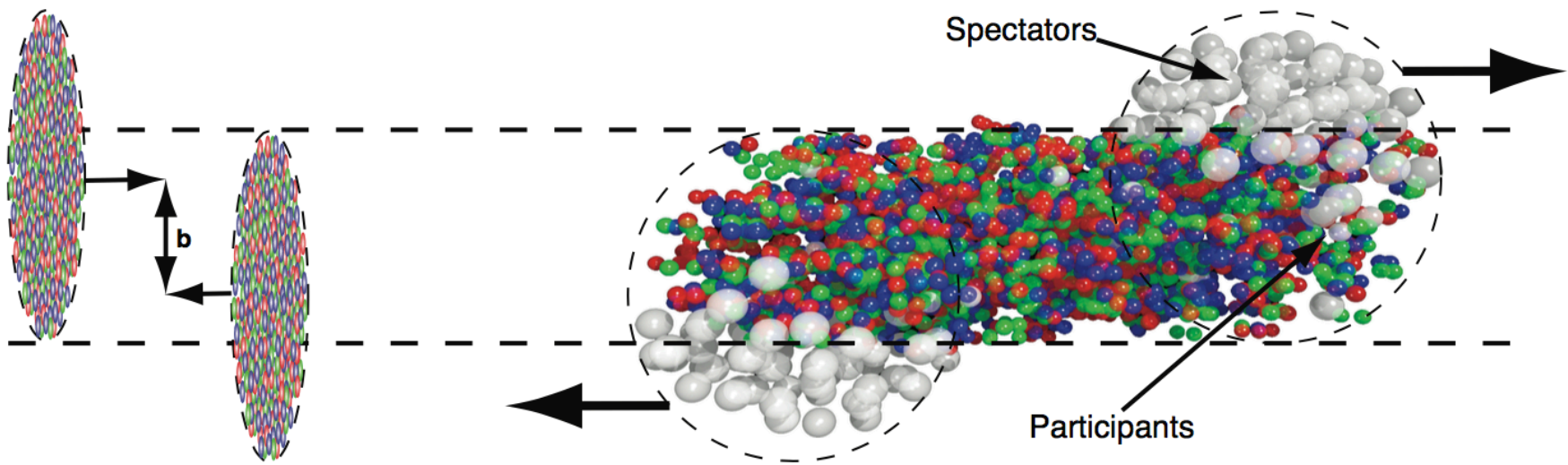
$$dn/d\phi \sim 1 + 2 v_2(p_T) \cos (2 \phi)$$

$$\frac{dN}{d(\phi - \Phi_n)} = N_0 \left[ 1 + 2 \sum v_n \cos \{n(\phi - \Phi_n)\} \right]$$

$$v_n = \langle \cos \{n(\phi - \Phi_n)\} \rangle$$

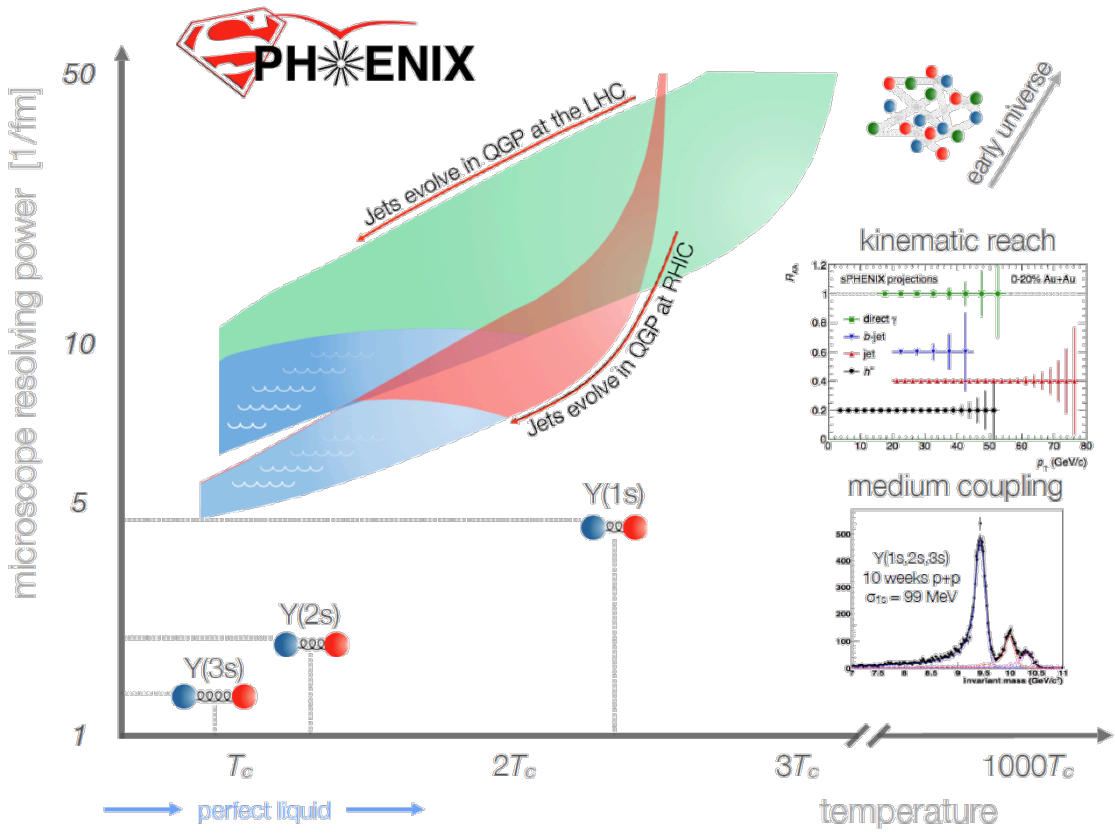
V3 and higher tells of fluctuations







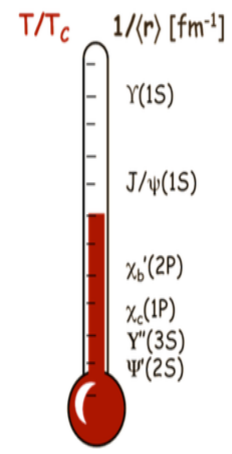
# QGP program near $T_c$



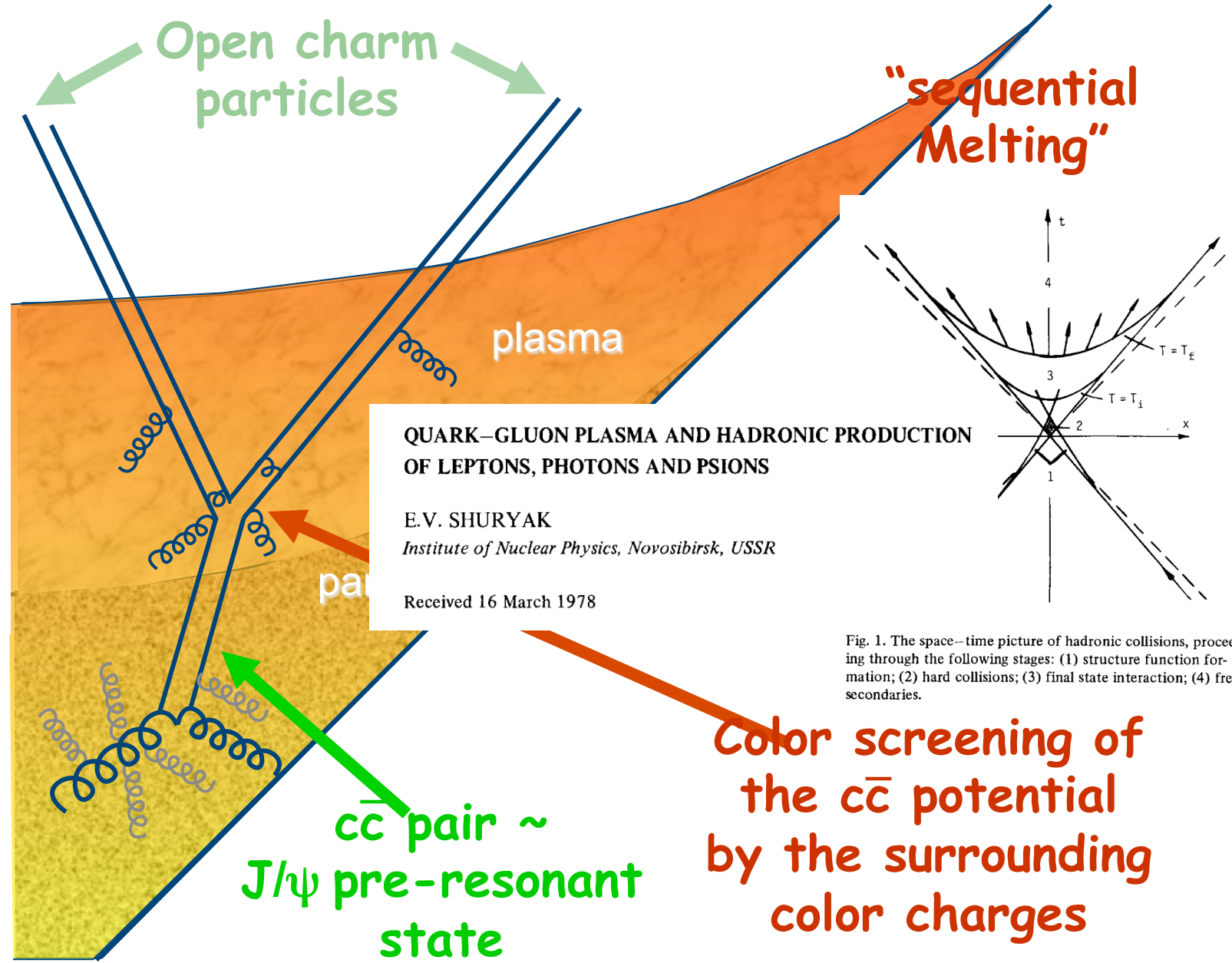
● Detailed inspection of QGP near  $T_c$  using probes over a broad range of scales

- Jet and Di-jet
- $\gamma$ -jet correlations
- Heavy flavor jets
- Separated  $Y(1s)$ ,  $Y(2s)$ ,  $Y(3s)$

# J/ψ production and differential suppression



QGP thermometer based on sequential suppression of quarkonia. courtesy: A. Mocsy



QUARK–GLUON PLASMA AND HADRONIC PRODUCTION OF LEPTONS, PHOTONS AND PSIONS

E.V. SHURYAK  
*Institute of Nuclear Physics, Novosibirsk, USSR*

Received 16 March 1978

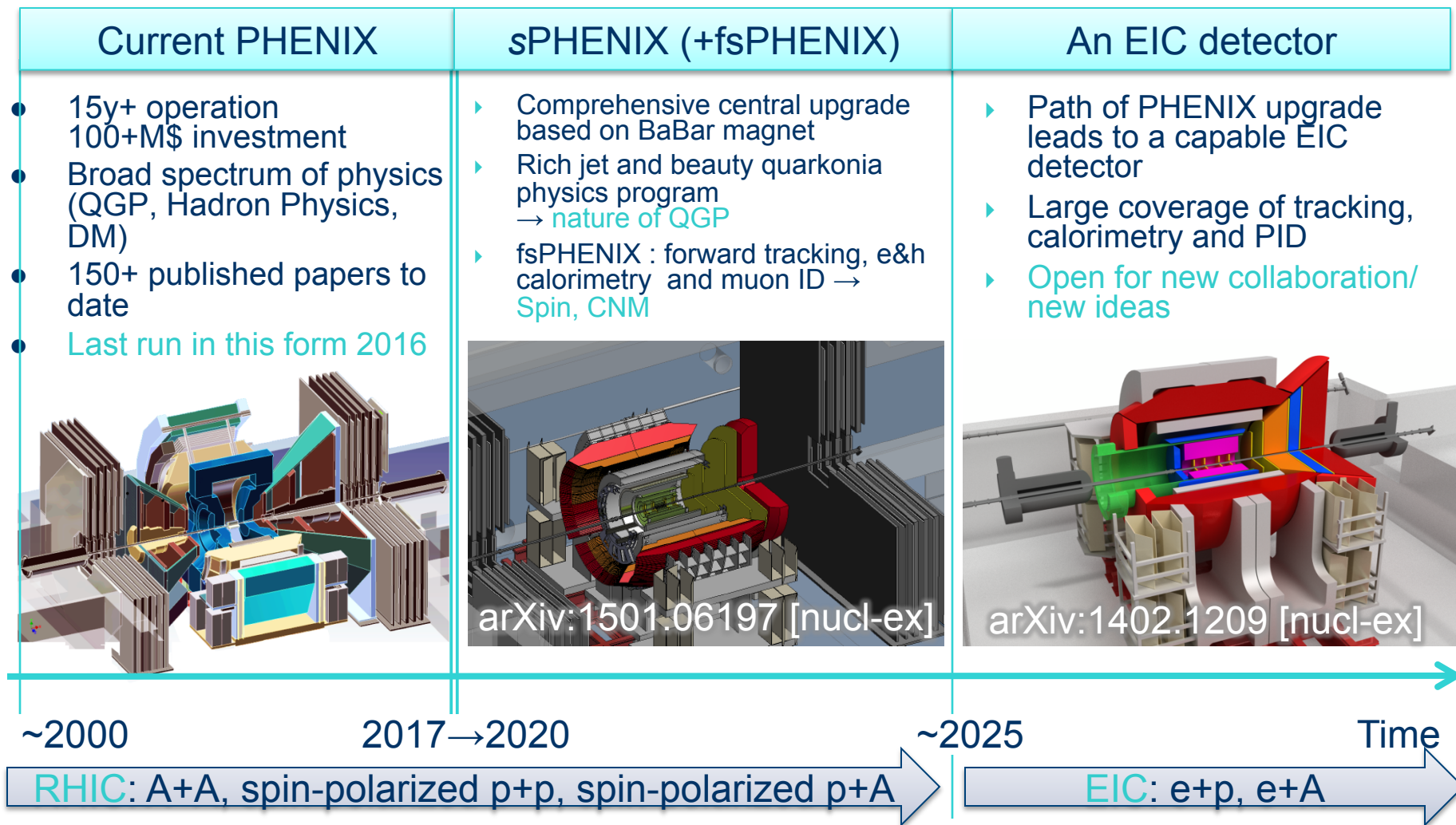
Fig. 1. The space–time picture of hadronic collisions, proceeding through the following stages: (1) structure function formation; (2) hard collisions; (3) final state interaction; (4) free secondaries.

Color screening of the  $c\bar{c}$  potential by the surrounding color charges



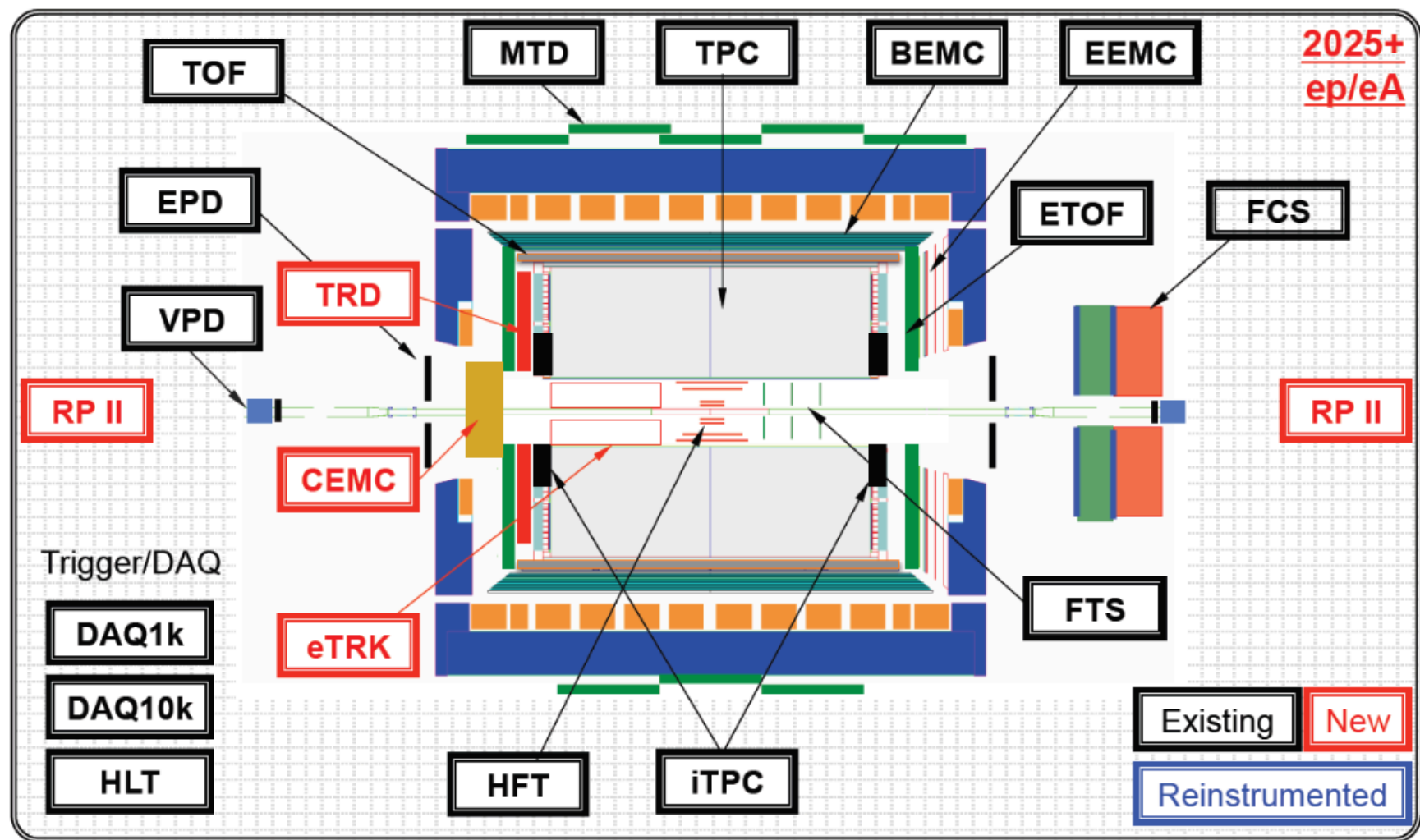
# Evolution of the Experiment (PHENIX)

Documented: <http://www.phenix.bnl.gov/plans.html>



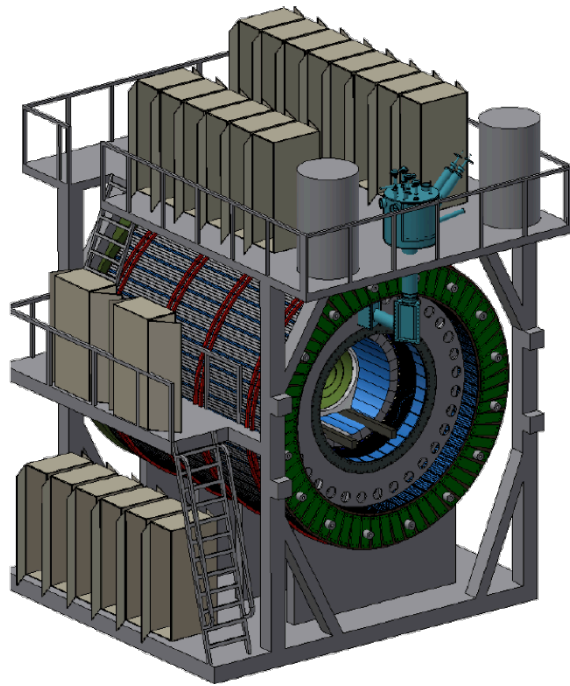


# STAR forward instrumentation upgrade

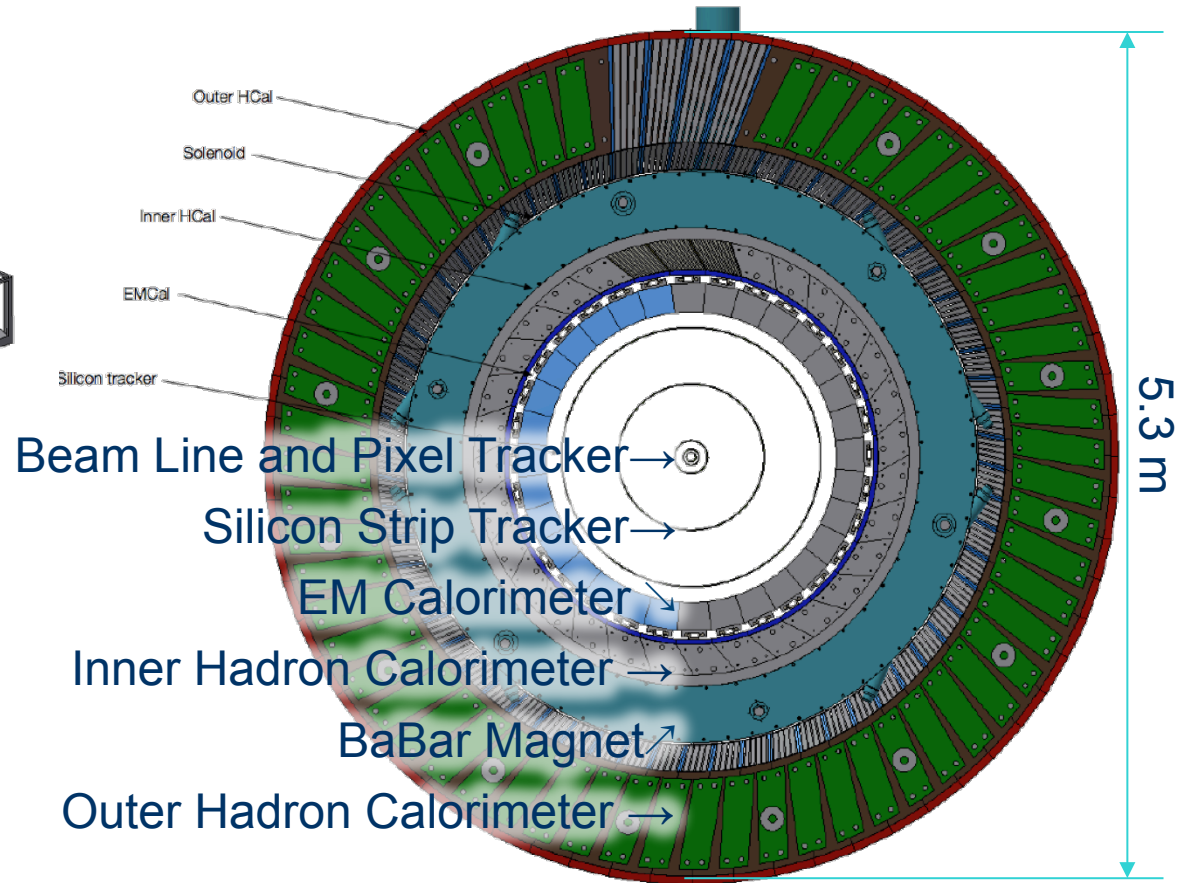




# sPHENIX experiment (already in construction stage .... illegal )



**Detailed CAD model**



**Beam view**

# Move BaBar Magnet

Jan 16 -> Feb 3 2015

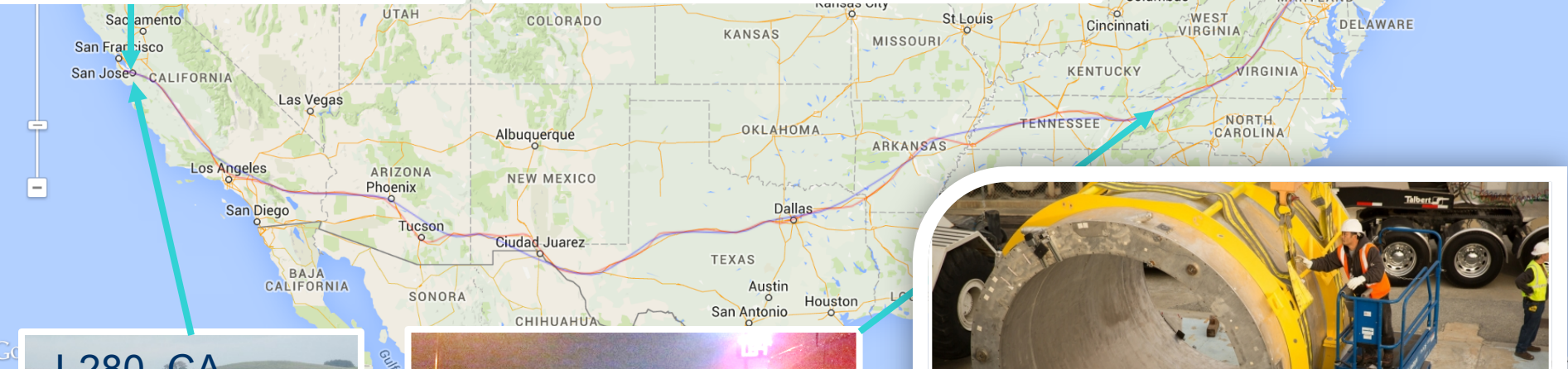
SLAC  
Jan 16, 2015



Magnet Testing Area, BNL



BNL Gate  
Feb 3, 2015



I-280, CA



Near Oak Ridge, TN



In the News

breaking  
January 16, 2015

## 20-ton magnet heads to New York

A superconducting magnet begins its journey from SLAC laboratory in California to Brookhaven Lab in New York.

By Justin Eure

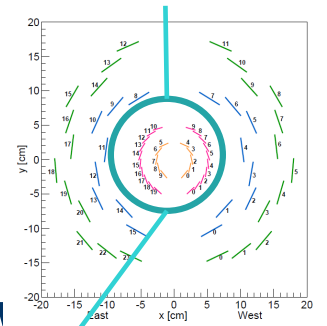
Photo by Andy Freeberg, SLAC National Accelerator Laboratory



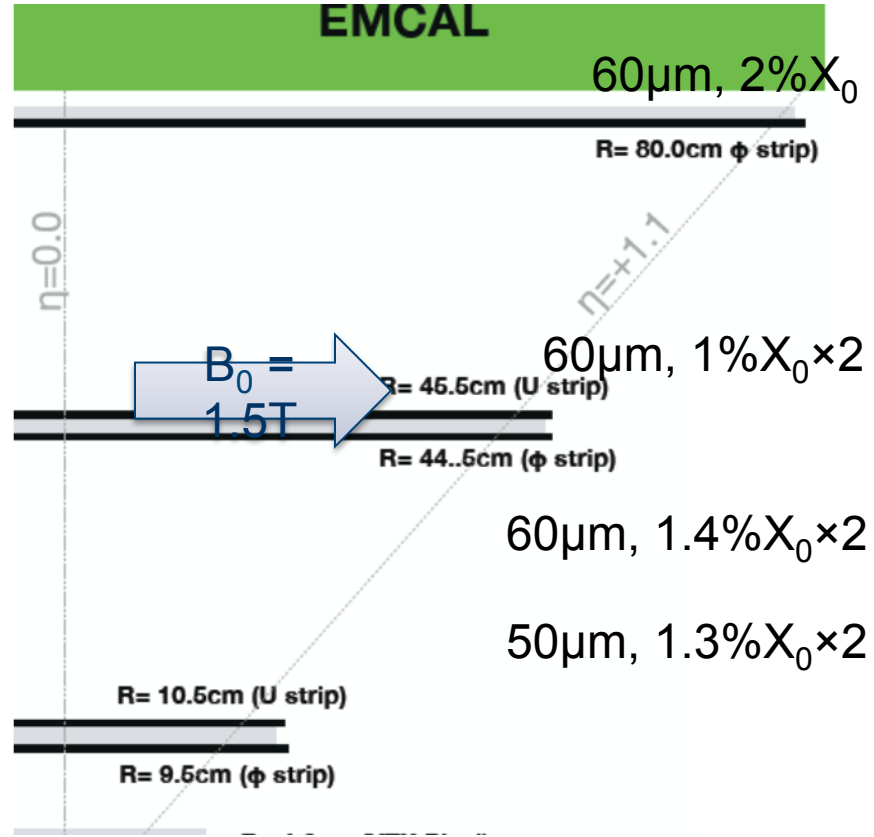
# Tracking : Reconfigure existing Silicon Tracker

Restacking PHENIX Pixel Tracker

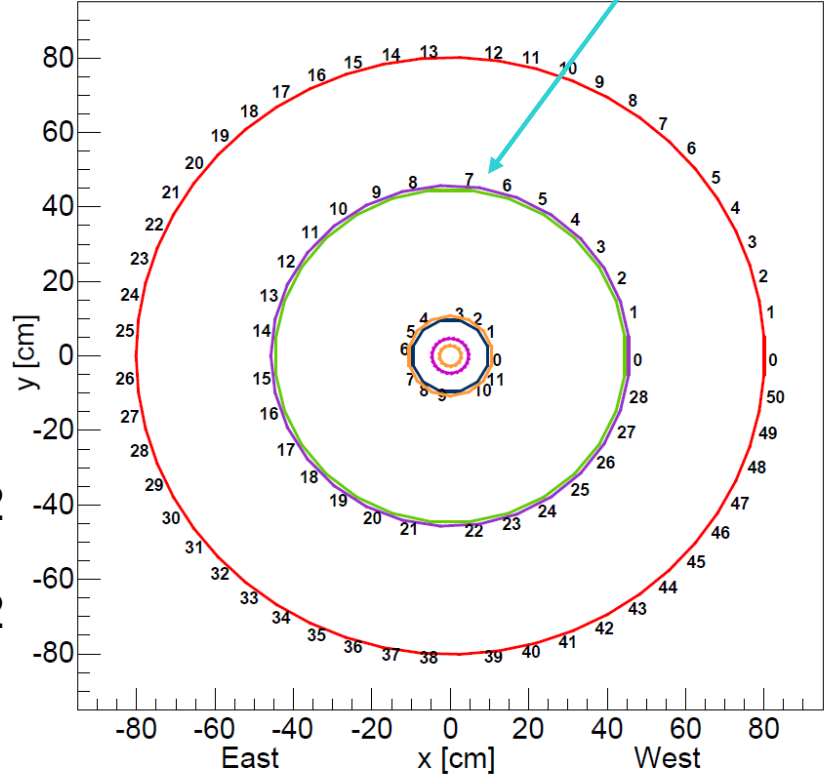
Also in study: a TPC for outer layer tracking



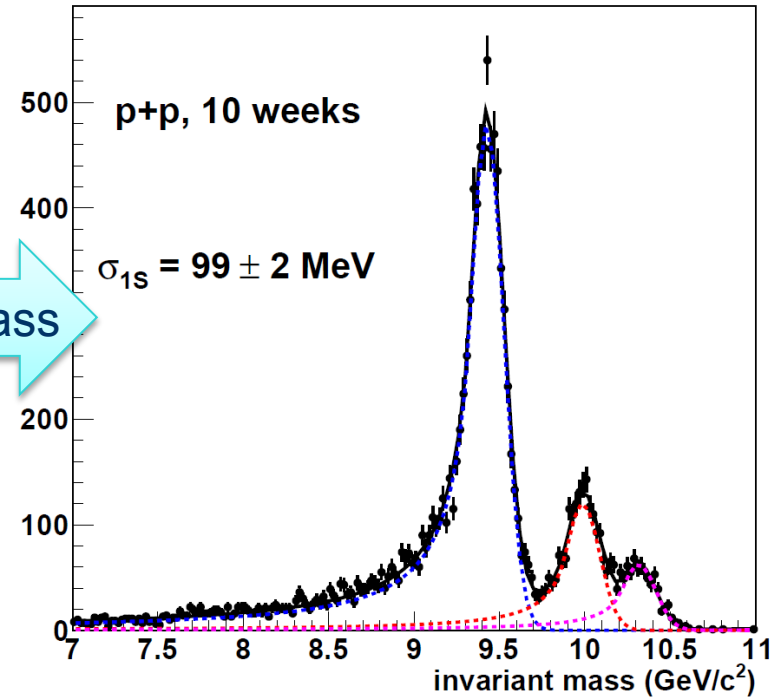
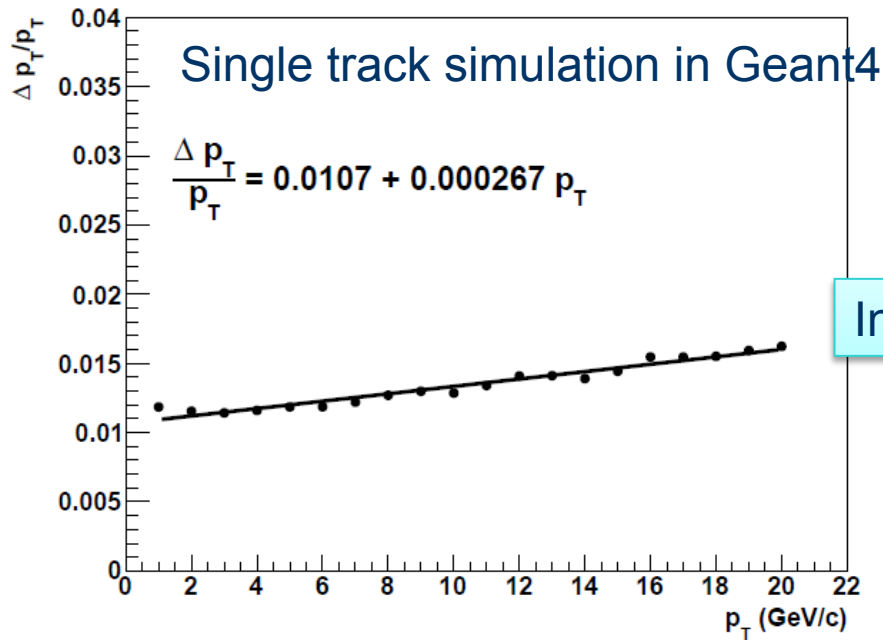
## Side view



## Beam View



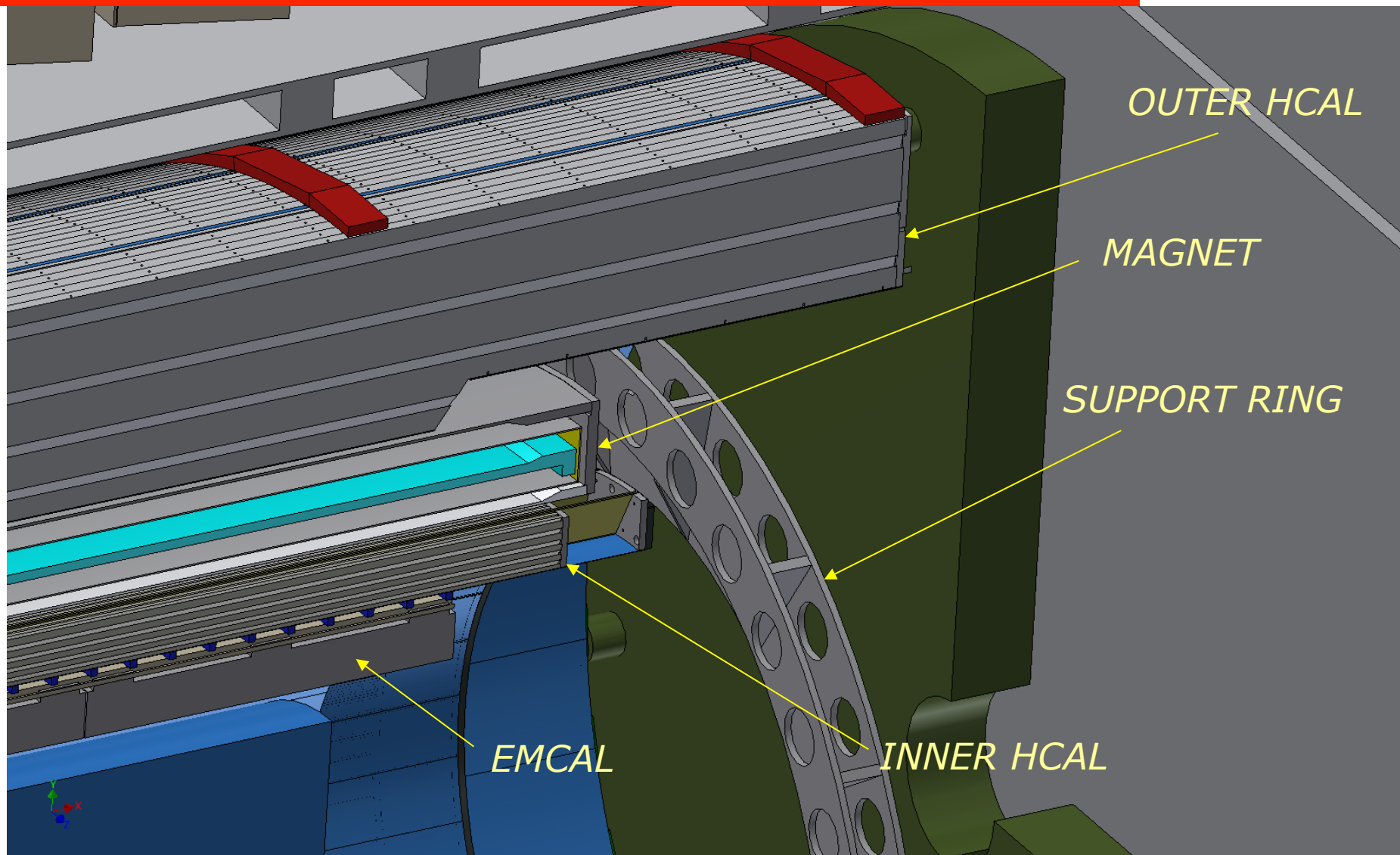
## Invariant mass for $e^+e^-$ pairs



Also full detector HIJING simulation in Geant4  
Eff. = 92% at 1 GeV/c and 97% at high  $p_T$ .

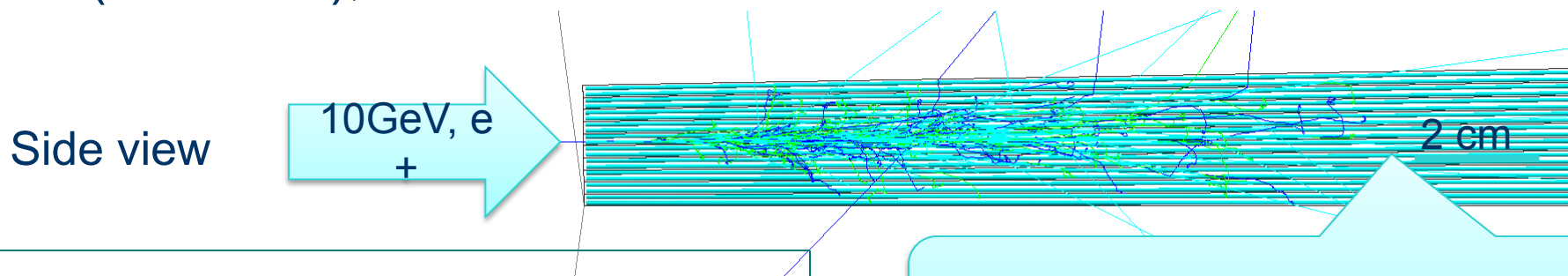


# Backbone: New Jet and EM Id Calorimetry

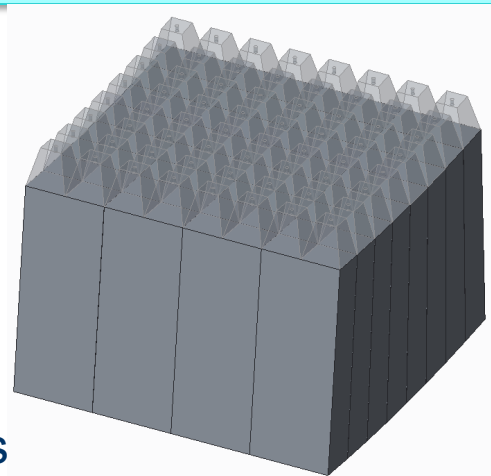
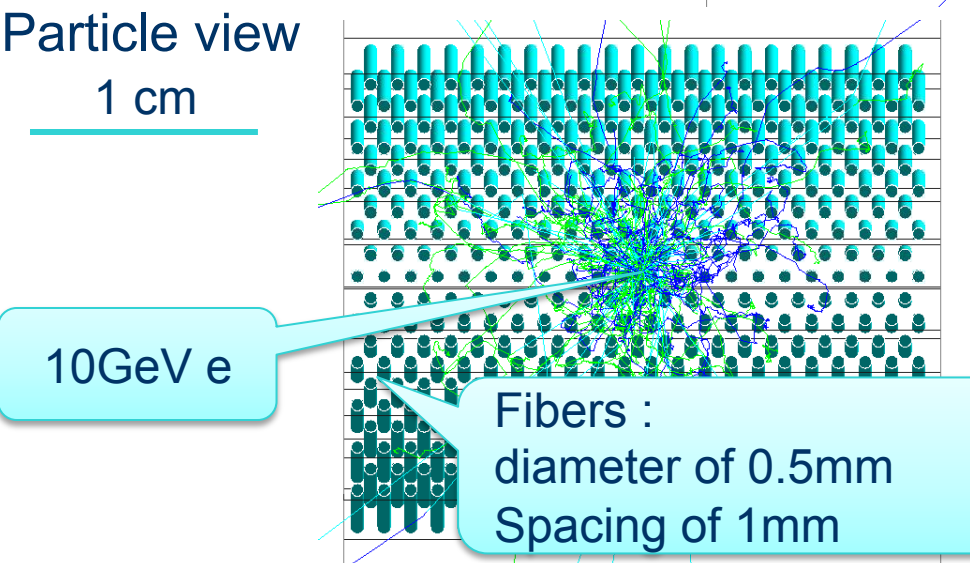


# Electron ID: EM Calorimeter

- Electron ID using a compact EMCal with assistance from inner Hcal ( $|\eta| < 1$ )
- Scintillation fiber-W powder sampling calorimeter (SPACAL),  $dE/E \sim 12\%/\sqrt{E}$

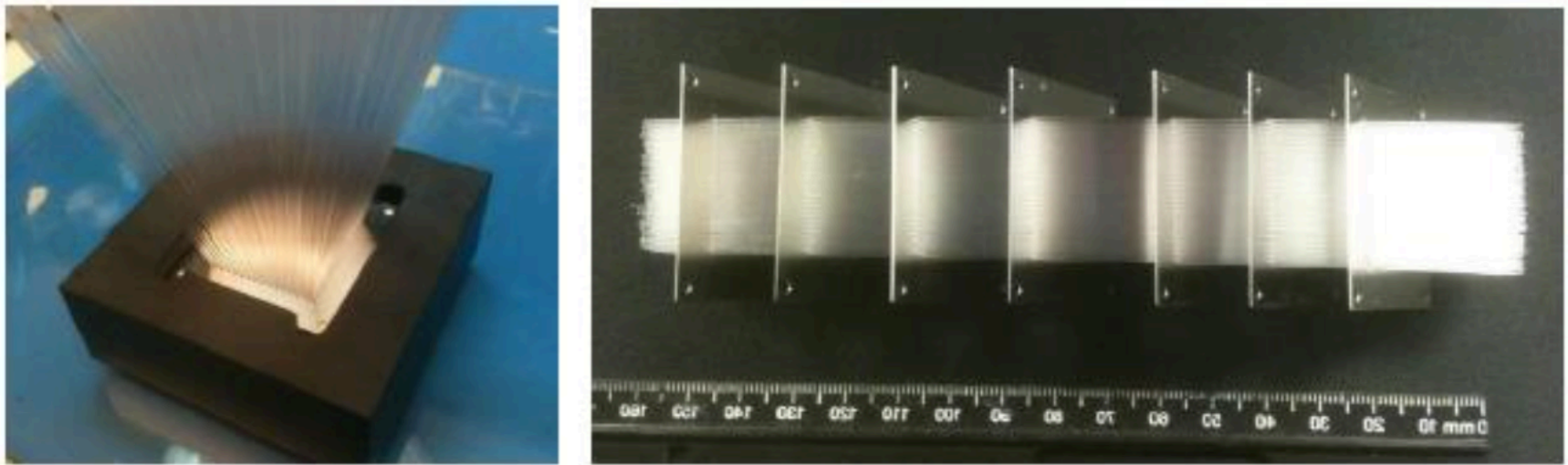


Tapered to form full cylinder  
Azimuthally projective fibers



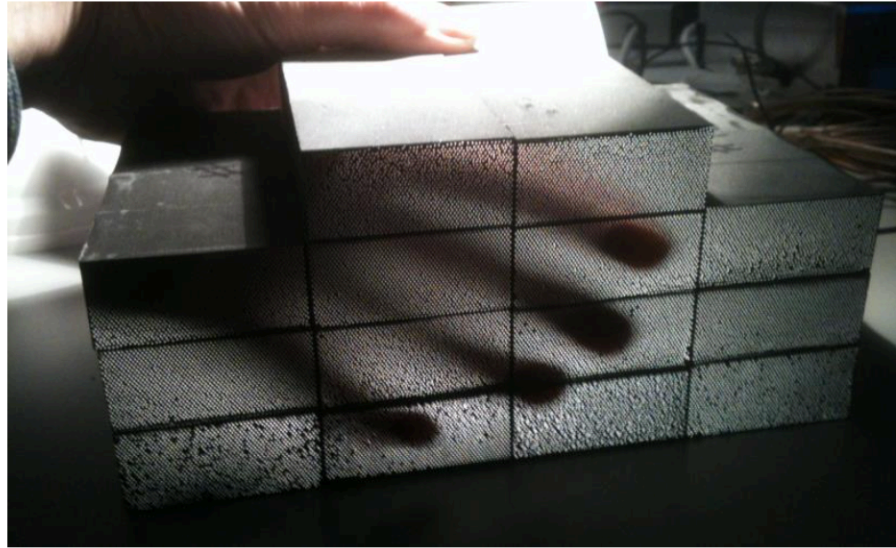


# Dealing with technological challenges

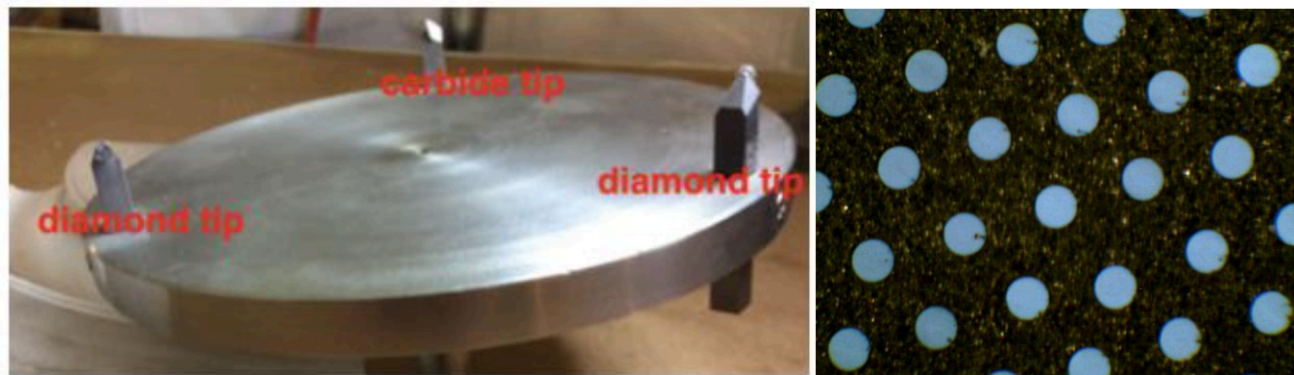


**Figure 2.8:** Left: Fibers filling a stack of tapered hold meshes which are separated by only a small amount to enable filling. Right: Fiber assembly after fully separating the meshes in preparation for insertion in the mold.

# Bricksmanship in modern physics



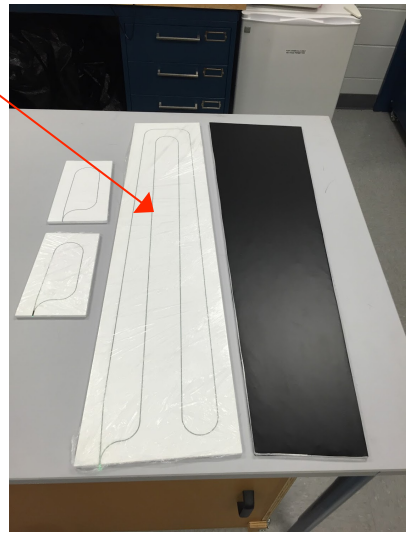
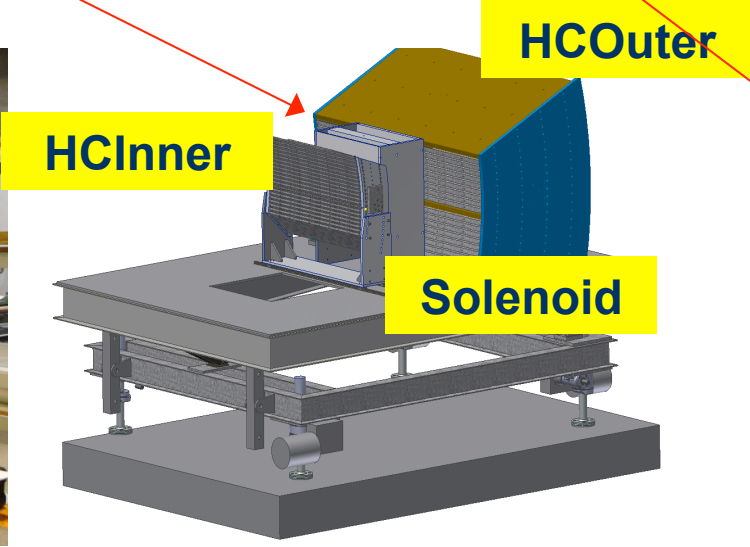
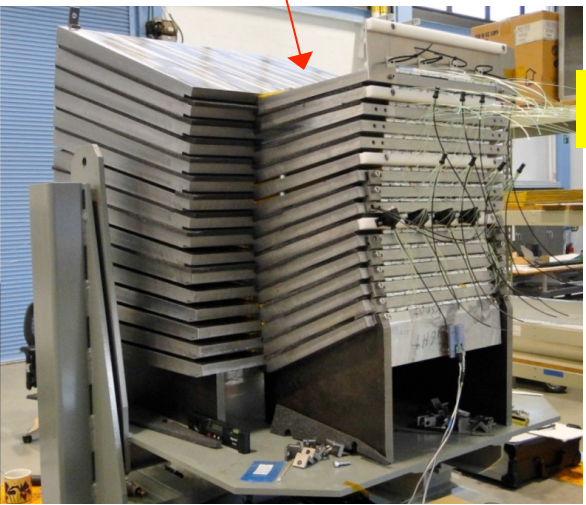
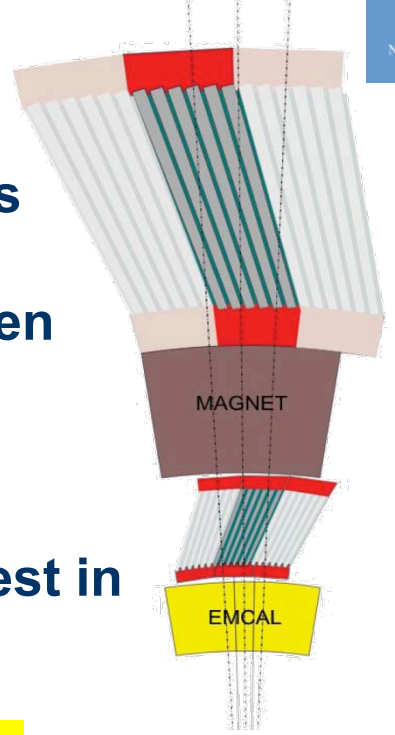
**Figure 2.4.** Modules produced at UIUC for the 8x8 tower prototype



**Figure 2.5.** Left: Fly cutting tool used at UIUC to finish the ends of the fibers. Right: Fibers ends after fly cutting step.

# Hadron Calorimeter

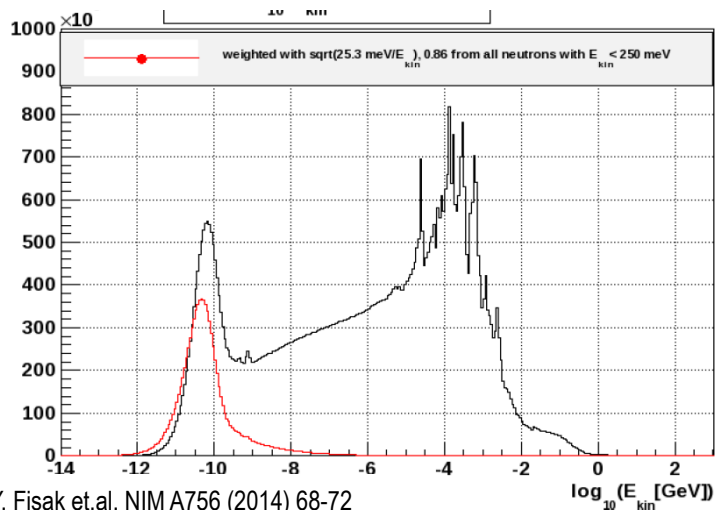
- Novel design using tilted iron plates doubling as field return
- Active medium – scintillators in the gaps between plates
- Optical readout (WLS fibers and SiPM's);
- PoP Prototype tested in FermiLab in 2014
- System prototype is in assembly stage. Beam test in April 2016 at FNAL





# Radiation Damage in SiPMs

## Estimated neutron flux in the STAR IR



Y. Fisak et.al. NIM A756 (2014) 68-72

Damage is caused mainly by neutrons ( $E \sim \text{MeV}$ )

Measure thermal neutron flux in RHIC IR and estimate MeV equivalent neutrons using MC

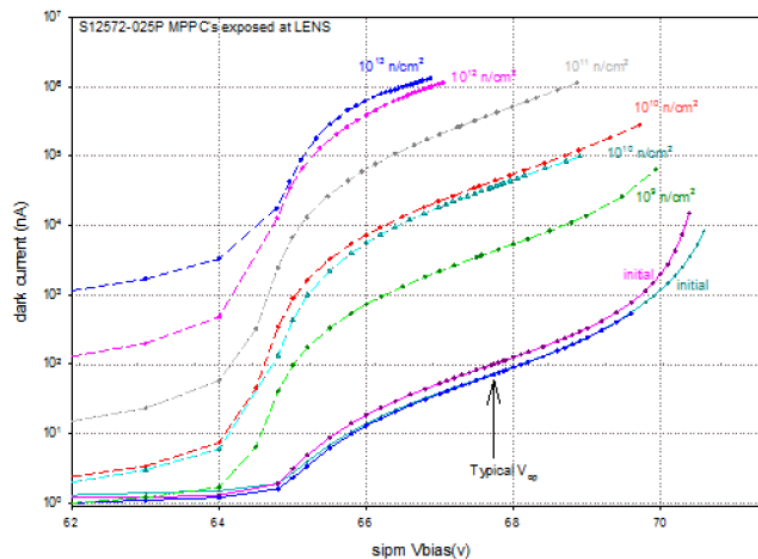
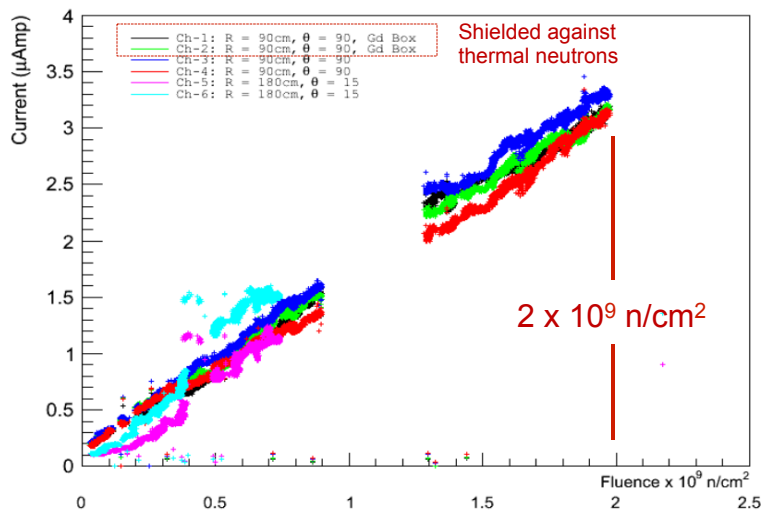
Estimates in STAR for 2013 run ( $L=526 \text{ pb}^{-1}$ ):

$R= 3\text{-}8 \text{ cm}, |Z| < 10 \text{ cm} : \Phi_{\text{eq}} \sim 8 \times 10^{10} \text{ n/cm}^2$

$R= 100 \text{ cm}, Z = 675 \text{ cm} : \Phi_{\text{eq}} \sim 2.2 \times 10^{10} \text{ n/cm}^2$

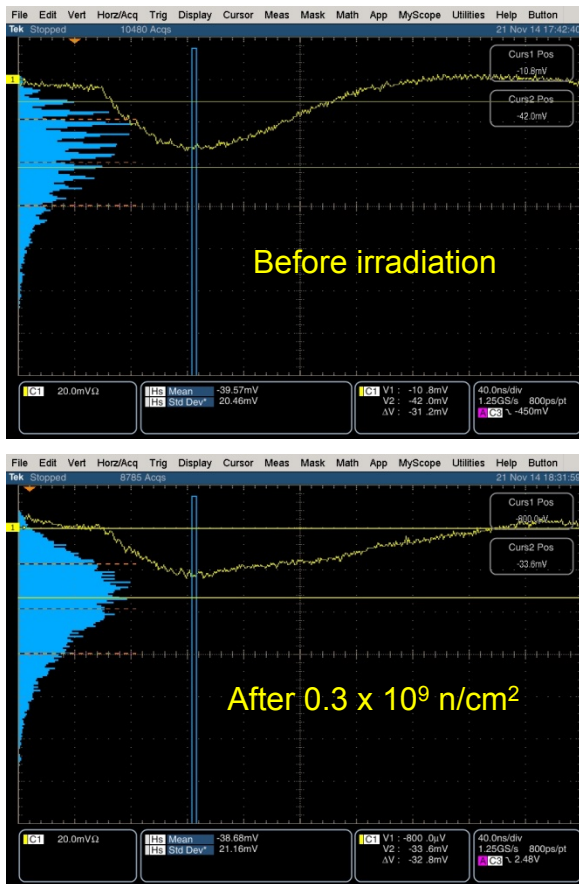
## Neutron measurements at the Indiana University LENS Facility

## Measured neutron flux in the PHENIX IR



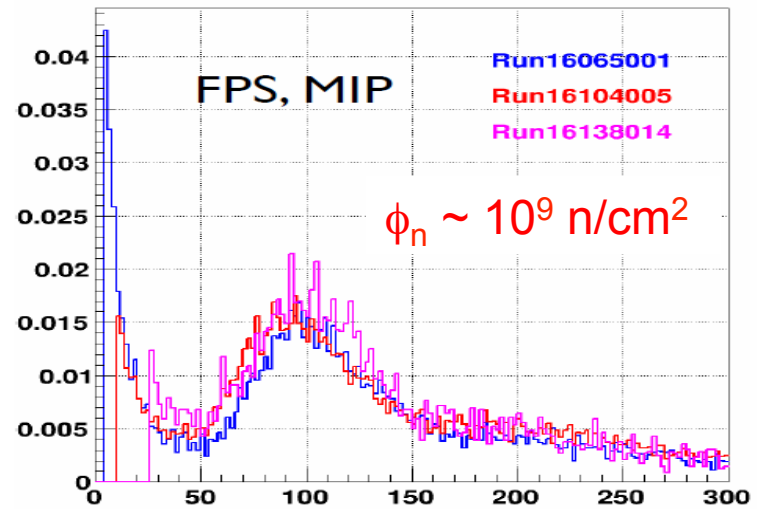
# Radiation Damage in SiPMs

Hamamatsu S12572-025P



Primary effect seems to be increase in noise and not loss of PDE

MIP peak for STAR Forward Preshower detector during RHIC Run 15



O. Tsai, EIC R&D Report, July 2015

Operationally we plan to keep  $V_b$  constant for currents up to  $\sim 1 \text{ mA}$

Will require cooling to maintain  $\sim 20^\circ \text{ C}$

# EM Calorimeter Energy resolution

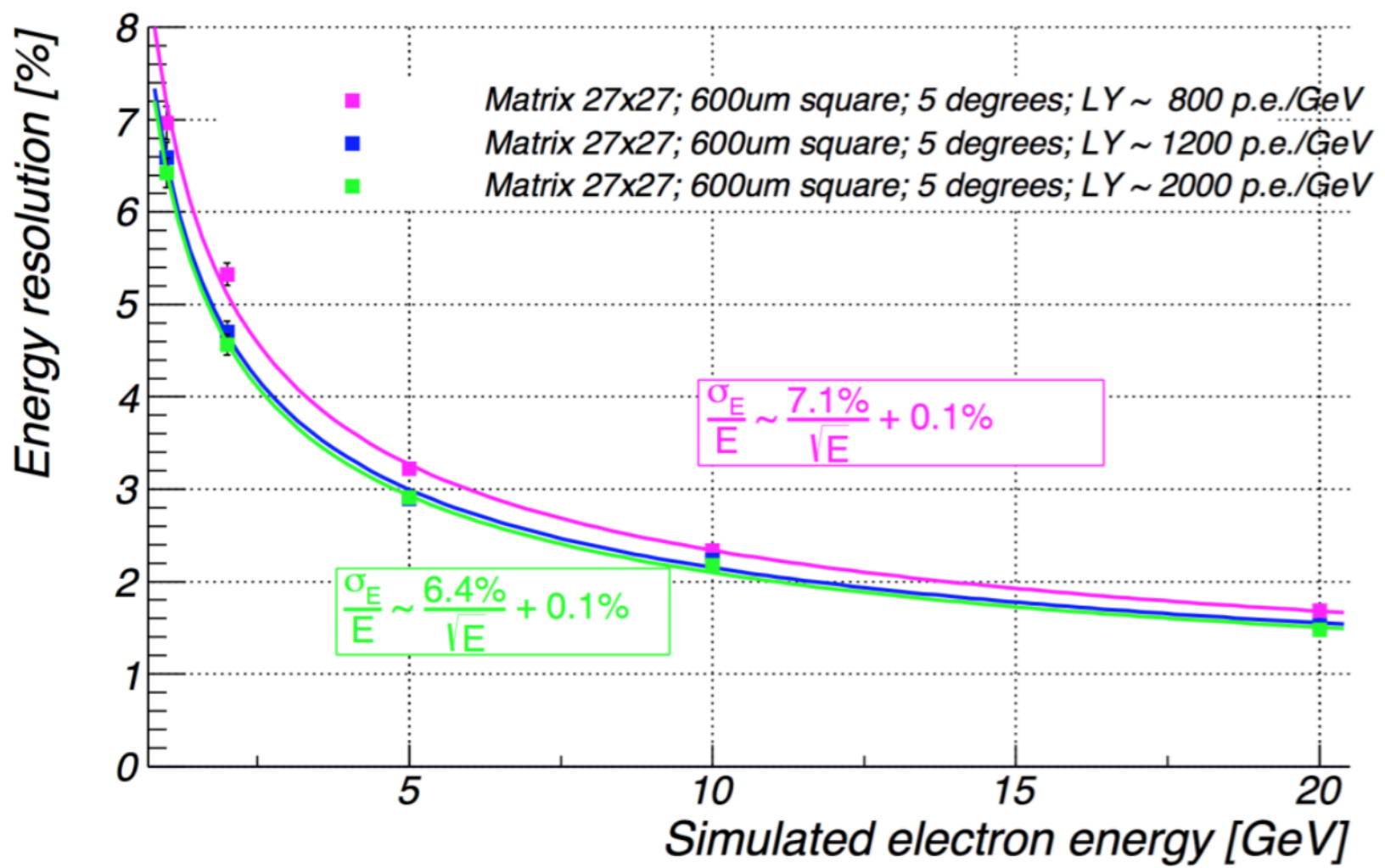
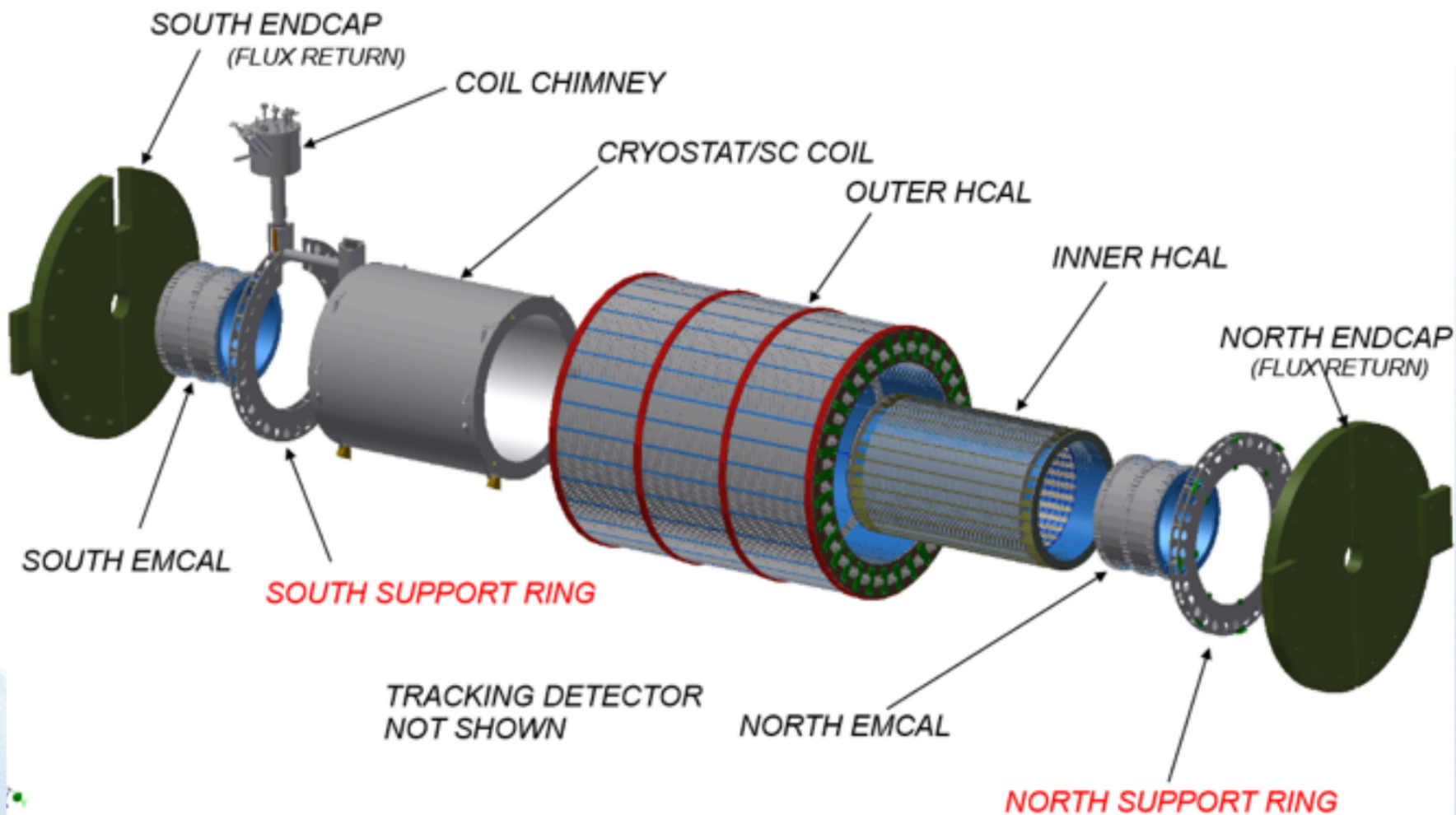


Figure 13. Expected energy resolution of new BEMC

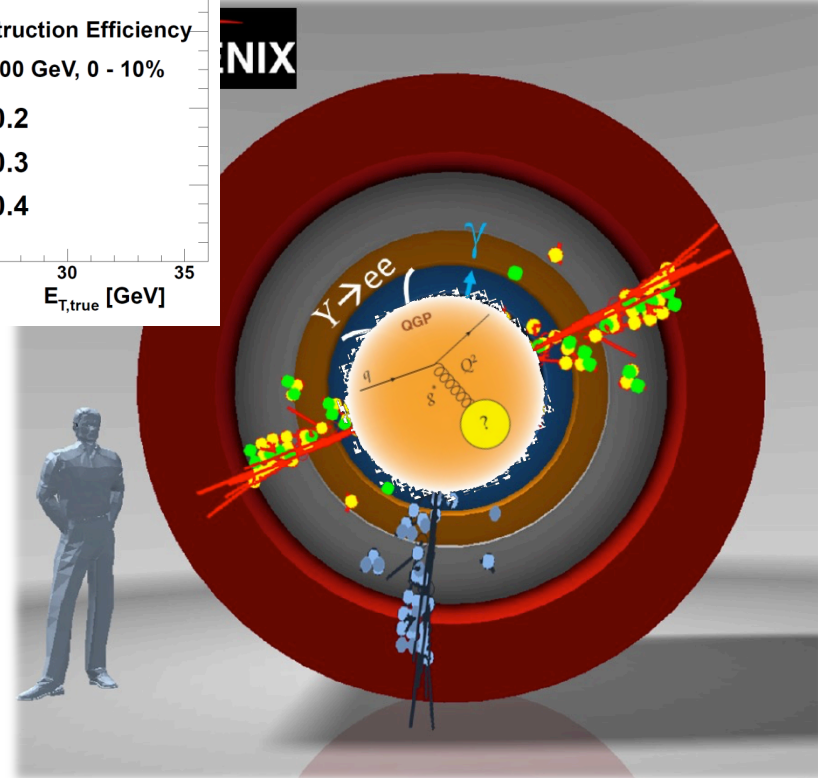
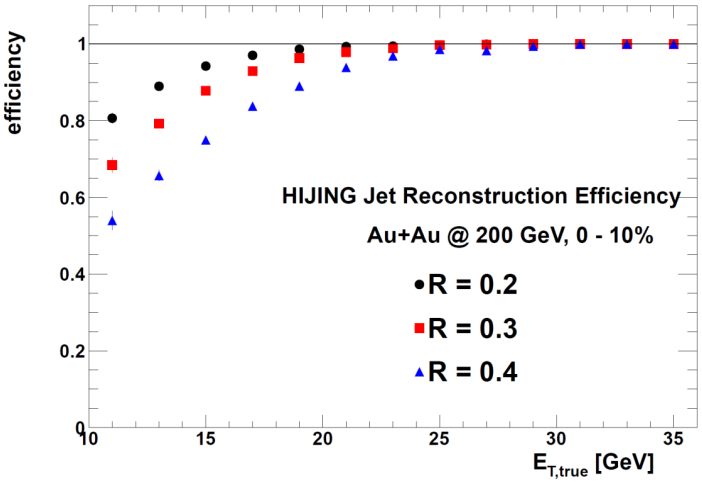


# sPHENIX exploded view

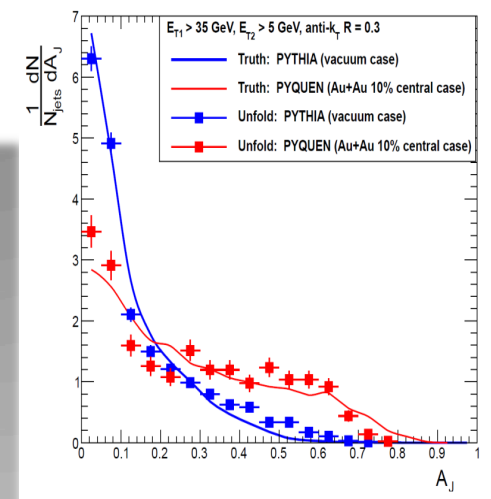


# Use jets as probe of QGP in sPHENIX

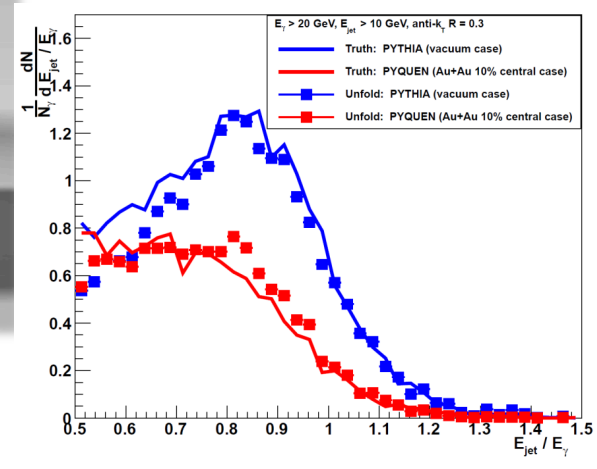
## Efficiency



## Di-jets



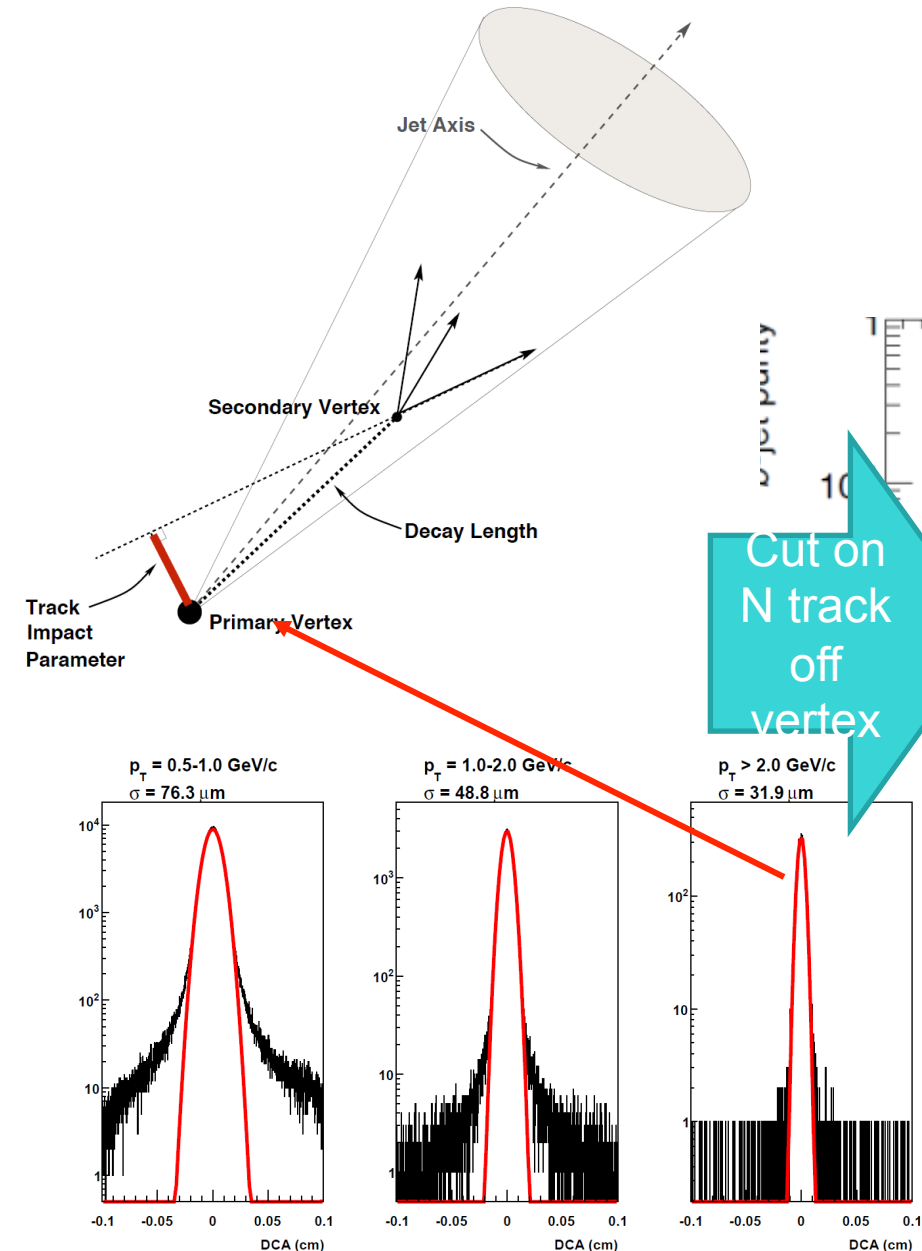
## Photon-jet



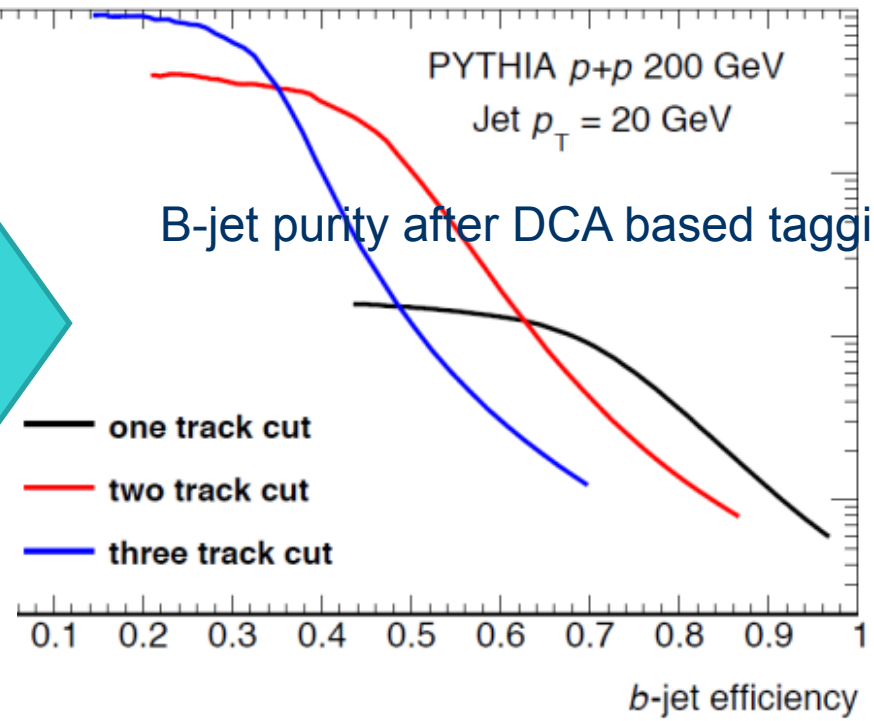
# B-quark jet tagging

Heavy quark provide very different  
Sensitivity to collision and radiative energy  
Loss in QGP from light quark/gluon

Probed by heavy quark jets at sPHENIX



Cut on  
N track  
off  
vertex



B-jet purity after DCA based tagging

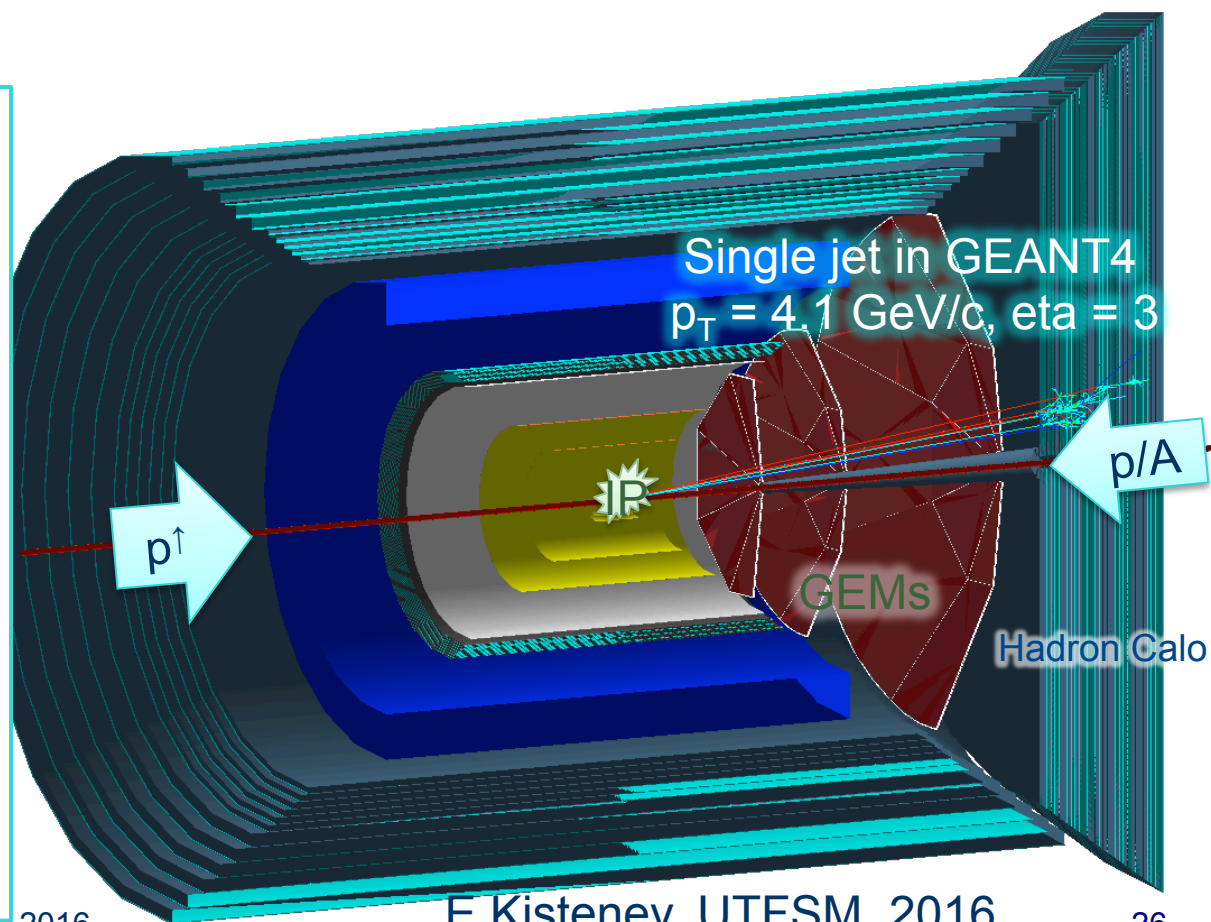


# Forward spectrometer of sPHENIX: fsPHENIX

- Shared detector with future eRHIC program and deliver an **unique forward program** with RHIC's pp/pA collision
- **white paper** submitted to BNL in Apr 2014: <http://www.phenix.bnl.gov/plans.html>

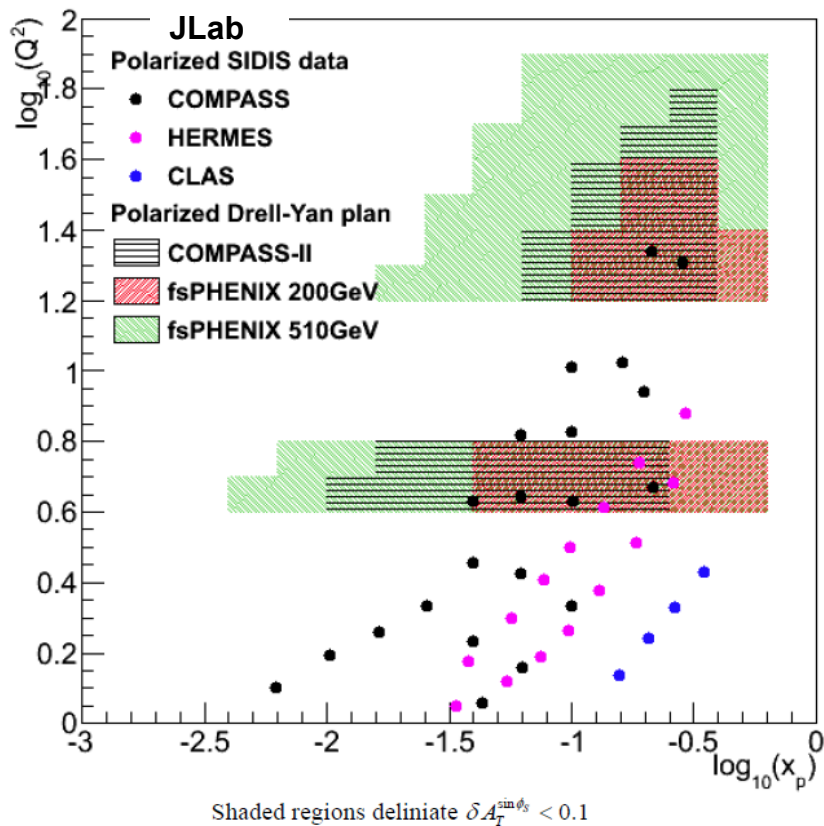
**EIC detector GEM + H-Cal**  
 → Forward jet with charge sign tagging  
 →  $A_N$  in hadron collisions  
 → polarized Drell-Yan with muons  
 → Forward-central correlations

+ central detector (sPHENIX)  
 + reuse current forward silicon tracker & Muon ID detector

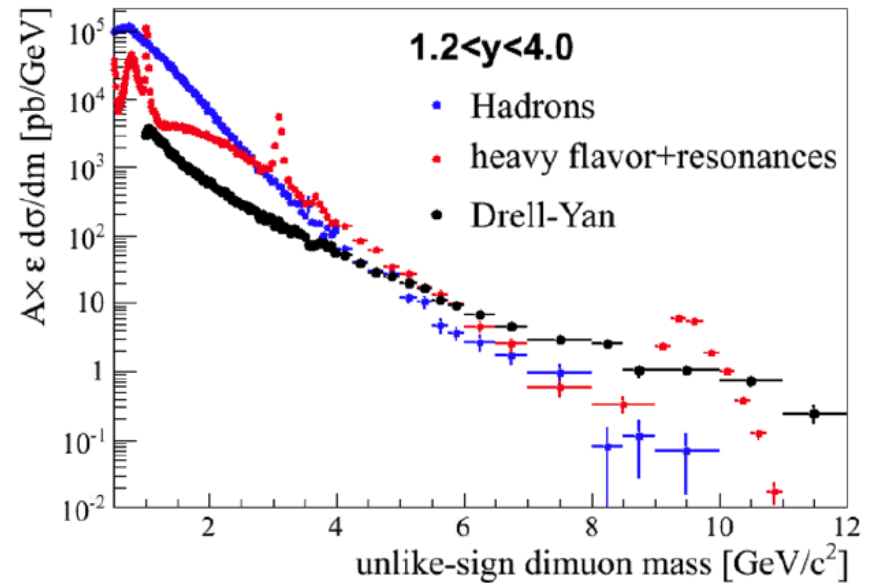


# fsPHENIX DY – challenging and very interesting

## Statistics-kinematic coverage comparisons



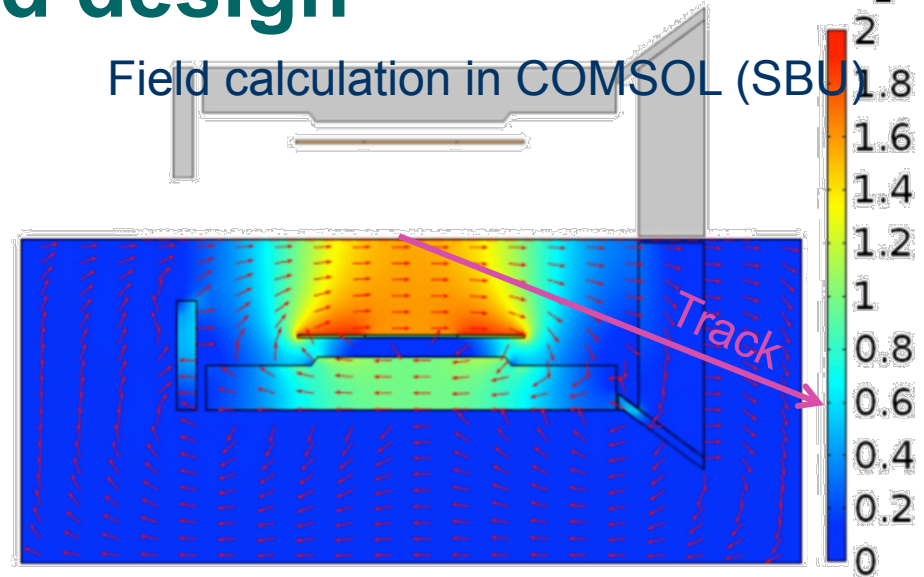
## Major challenge on background and potential improvement



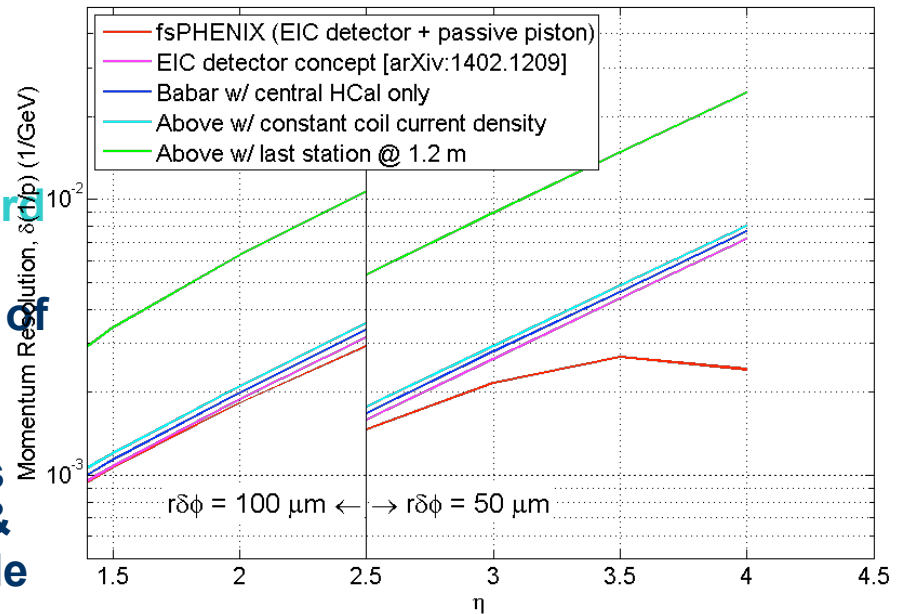
# Challenge: Forward field design

- **BaBar superconducting magnet**
  - Length: 385 cm
  - Nominal field: 1.5T
  - Designed for homogeneous B-field in **central tracking**
- **Field calculation and yoke tuning**
  - Field calculated and cross checked: **POISSON, FEM, OPERA and COMSOL**
- **For forward spectrometer**
  - **Longer field volume for forward tracking**
  - **Higher current density at end of the magnet -> better forward bending**
  - **To work well with RICH needs field-shaping yoke: Forward & central Hcal + Steel lampshade**

Field calculation in COMSOL (SBU)



Momentum Resolution at high momentum limit

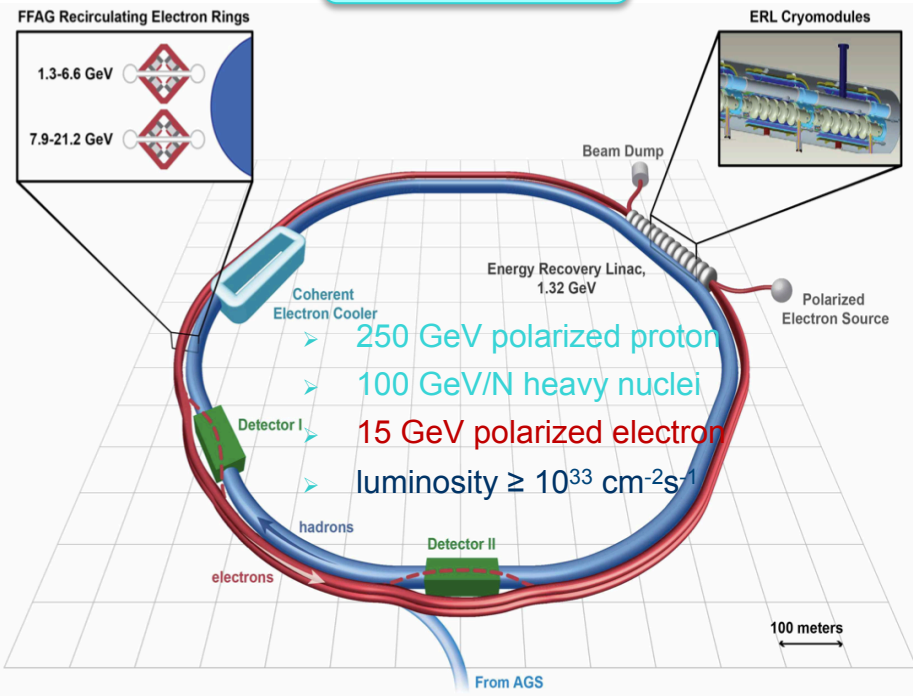




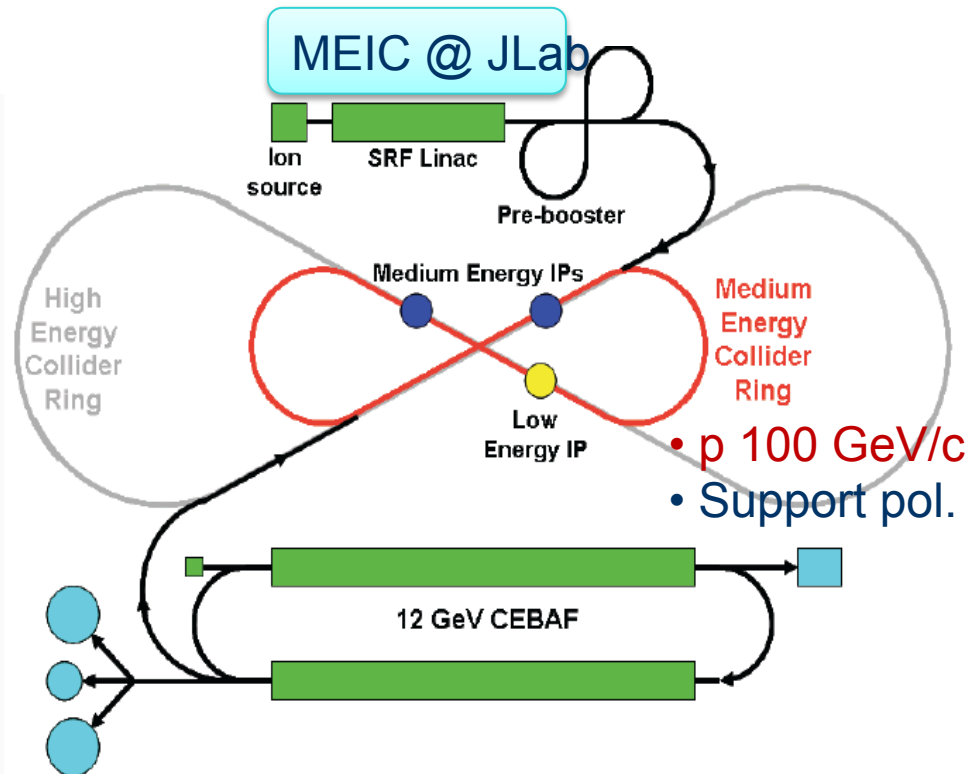
# High energy polarized EIC concepts

- Highly polarized electron and nucleon beams
- Ion beams from D- to U or Pb
- Variable C.M. energy from 20 -> 100 GeV (150 upgradable)
- High collision luminosity  $10^{33}$ - $10^{34}$   $\text{cm}^{-2}\text{s}^{-1}$   
(HERA luminosity  $\sim 5 \times 10^{31}$   $\text{cm}^{-2} \text{s}^{-1}$ )
- Possibility of more than one interaction regions

eRHIC @ BNL



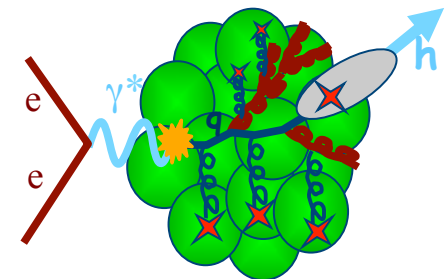
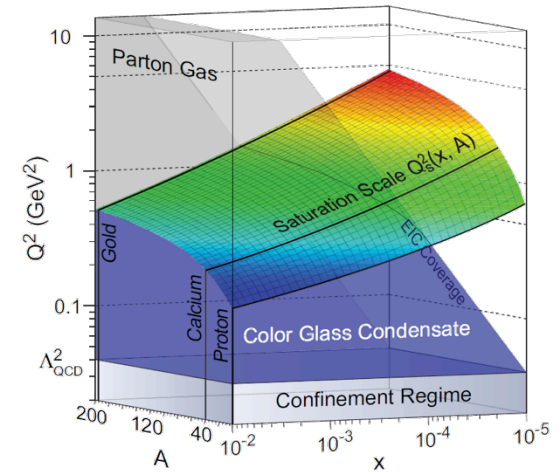
MEIC @ JLab



# Physics goals: nucleus as a laboratory for QCD

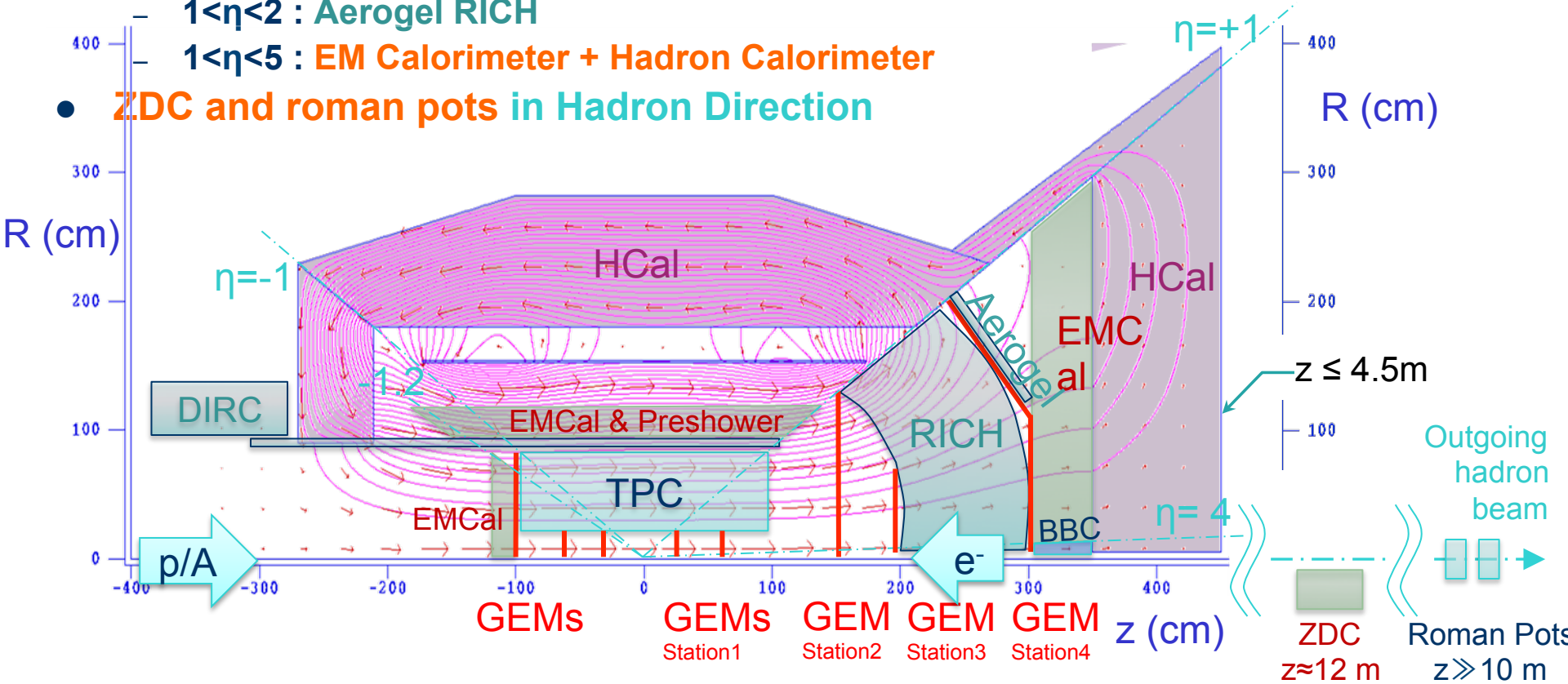
Outlined in EIC white paper, arXiv:1212.1701

- The compelling questions:
  - Where does the saturation of gluon densities set in?
  - How does the nuclear environment affect the distribution of quarks and gluons and their interactions in nuclei?
- Deliverable measurement using electron-ion collisions
  - Probing saturation of gluon using diffractive process and correlation measurements
  - Nuclear modification for hadron and heavy flavor production in DIS events; probe of nPDF
  - Exclusive vector-meson production in eA
- Leading detector requirement:
  - ID of hadron and heavy flavor production
  - Large calorimeter coverage to ID diffractive events
  - Detection/rejection of break-up neutron production in eA collisions



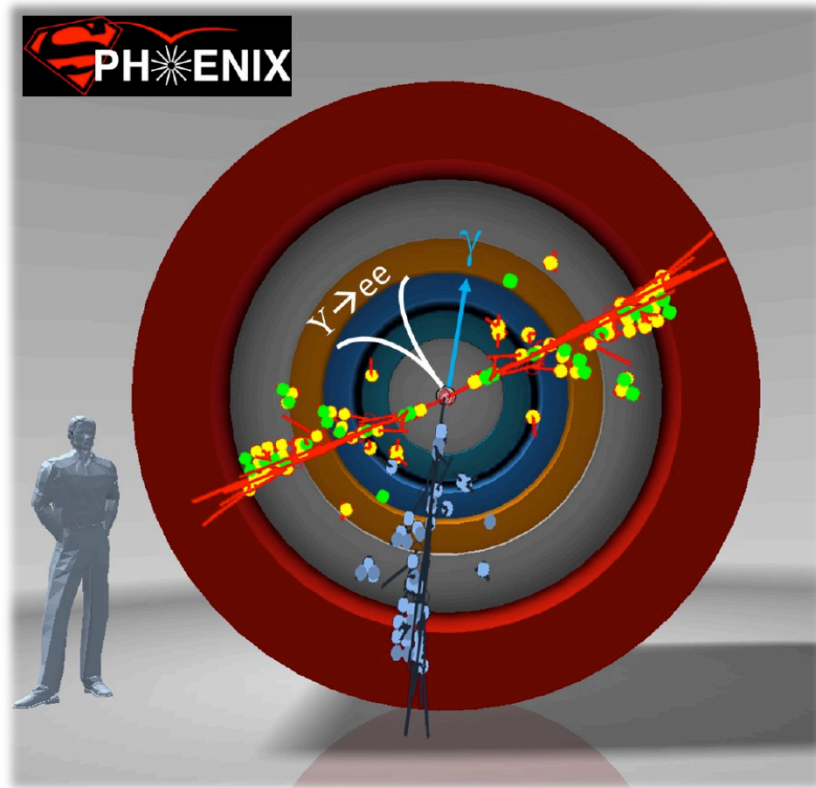
# eRHIC era: sPHENIX based concept for an EIC Detector

- $-1 < \eta < +1$  (barrel) : sPHENIX + Compact-TPC + DIRC
- $-4 < \eta < -1$  (e-going) : High resolution calorimeter + GEM trackers
- $+1 < \eta < +4$  (h-going) :
  - $1 < \eta < 4$  : GEM tracker + Gas RICH
  - $1 < \eta < 2$  : Aerogel RICH
  - $1 < \eta < 5$  : EM Calorimeter + Hadron Calorimeter
- ZDC and roman pots in Hadron Direction





# Summary



- RHIC program in this decade is about quantitatively studies of QGP near  $T_C$  using probes over a broad range of scales
- Initial stage of this program – sPHENIX – just underwent successful DOE scientific review;
- It got substantial bust from the shipment of BaBar magnet to BNL
- Both sPHENIX and STAR are developing forward upgrades aimed towards transverse spin physics;
- Both upgrade paths could lead to a capable EIC detector and broad ep/eA program

**Plenty of opportunities for Universities and good students**

# Motto of experimentalist (violated daily)

As forthwith declared on this day,  
Physics Experiment Electronics shall contain no:

- ❖ **Blueberry Pies**
- ❖ **Raspberry Pi's**
  - ❖ **Legos**
  - ❖ **Tamagotchis**
  - ❖ **Arduinos**
- ❖ **Game Controllers**
- ❖ **Garage Door Openers**

Or any other such technologies deemed to be unworthy of the professional and reliable operation of a world-class physics detector.

**The control devices that we are using are the type found in military, medical equipment and automobile engines. That's why your car doesn't just shut off in the middle of the Long Island Expressway. SB, 1/14/2016**