

# Towards the Final Telescope Sensor

## Status Report

Marc Winter (IPHC-Strasbourg)

*on behalf of IPHC and IRFU/Saclay*

▶ **More info. on IPHC Web site :** [http://wwwires.in2p3.fr/ires/web2/rubrique.php3?id\\_rubrique=63](http://wwwires.in2p3.fr/ires/web2/rubrique.php3?id_rubrique=63)

## OUTLINE

- **Strategy of the chip development (reminder)**
- **Col. // sensor prototyping:** *description of architecture, IDC prototype lab and beam test results*
- **Zero supp. and output memory  $\mu$ -circuits :** *SDC-2 prototype short description and test results*
- **The question of radiation tolerance**
- **Final chip : status of design and plans**
- **Summary - Outlook**

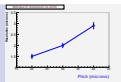

■ **Motivation for a dedicated beam telescope architecture:**

- ⇒ *beam intensity : read-out  $\lesssim 10^4$  frames / second*
- ⇒ *DUT surface & resolution requirements : active surface of  $1 \times 2 \text{ cm}^2$  with  $\gtrsim 0.5$  million pixels*
- ⇒ *sensor should incorporate zero suppression ⇒ + integrated signal discrimination*

■ **Development strategy:** *two prototyping lines pursued in parallel*

- ⇒ *column // architecture adapted to the required speed ▷ MIMOSA-16 ▷ **IDC/MIMOSA-22***
- ⇒ *integrated  $\emptyset$  and output memories adapted to the corresponding occupancy (e.g. SDC-2 / SUZE-01)*

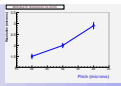

■ **Specific goals of IDC/MIMOSA-22 :**

- ⇒ *validate the fast read-out architecture developed in MIMOSA-16 (next slide ) at **Real Scale***
- ⇒ *extract an optimal pixel design (sensing diode characteristics)*
- ⇒ *improve the chip testability (JTAG, analog outputs, pads, ...)*

■ **Objective beyond IDC/MIMOSA-22 :**

- ⇒ *once validated, the IDC/M-22 architecture will be merged with SDC-2/SUZE-01*
  - ⇒ *Final Sensor (TC/MIMOSA-26), to be sent for fabrication in Autumn*

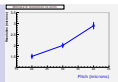

# Performances of a Small Prototype with Digitised Output

- MIMOSA-16 :
  - ◇ fabricated in 2006 (coll. with IRFU/Saclay)
  - ◇ 32 col. of 128 pixels (25  $\mu m$  pitch, integrated CDS )
  - ◇ 24 col. ended with an integrated discriminator
  - ◇ 4 different pixels (i.e. 4 sub-arrays)

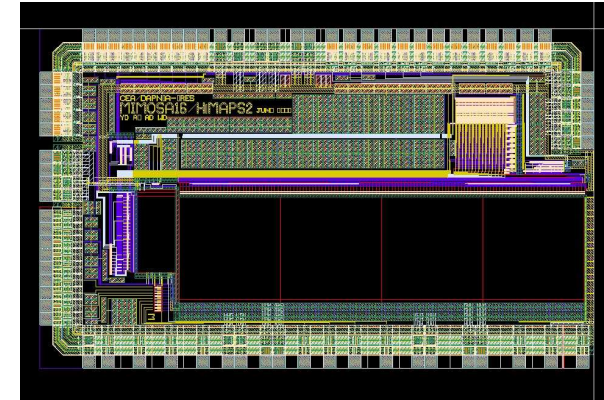

■ Tests at CERN-SPS ( $\sim 180 \text{ GeV } \pi^-$ ) in Summer 2007

→ results of one sub-array (S4)



Discri. threshold	Detection eff.	Fake rate	Resolution
4 mV	$99.96 \pm 0.03 \text{ (stat) } \%$	$\sim 2 \cdot 10^{-4}$	$\sim 4.8 - 5.0 \mu m$
6 mV	$99.88 \pm 0.05 \text{ (stat) } \%$	$< 10^{-5}$	$\sim 4.6 \mu m$

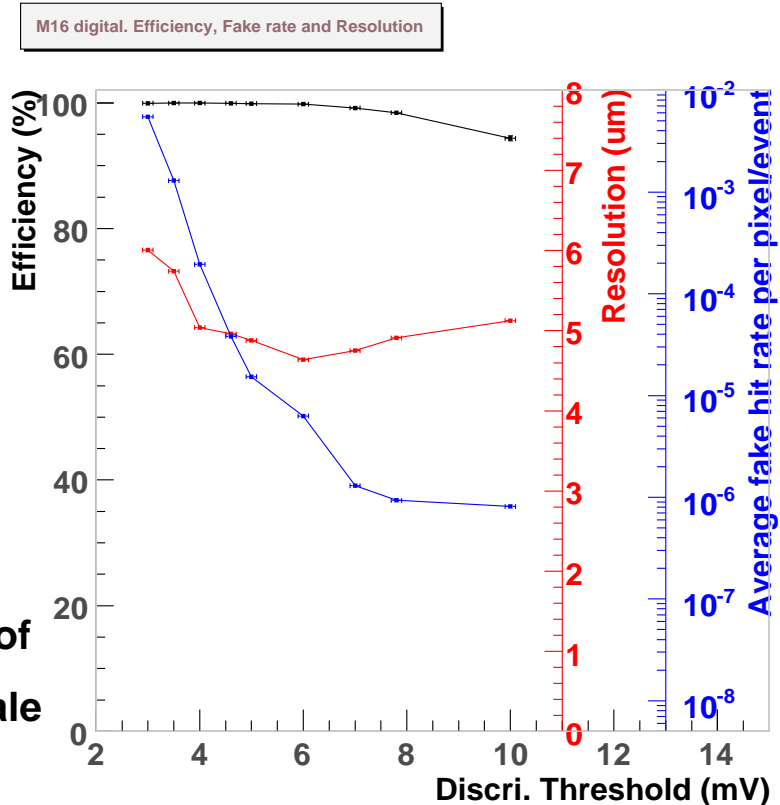

▷▷▷ Architectures of pixel (integrated CDS ) and of full chain made of "columns ended with integrated discri. " validated at small scale



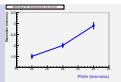

## ■ Topics investigated :

- ✧ *optimum between CCE ( $\Rightarrow$  large diode) and capacitive noise ( $\Rightarrow$  small diode)*
- ✧ *effective and robust pre-amplification scheme*
- ✧ *low noise (ionising) radiation tolerant design*
- ✧ *temperature dependence of performances*
- ✧ *performance uniformity over full active surface*
- ✧ *comparison with MIMOSA-16 performances (24 columns of 128 pixels)*

## ■ 5 pixel designs implemented, combining 2 reset & 2 ampli. variants (w/o rad. tol. diode, diff. diode sizes):

- ✧ *reset diode with (standard) common source amplifier : w/o improved gain*
- ✧ *self-biased feedback diode with common source amplifier with improved gain*
- ✧ *feedback reset diode with common source amplifier : w/o improved gain*

## ■ Status :

- ✧ *back from foundry since Feb.'08*
- ▷ *lab tests of analog and digital (discr.) outputs with  $^{55}\text{Fe}$  source completed*
- ▷ *first beam tests (CERN-SPS / August '08) partially analysed*

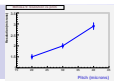

## Various pixel designs (rad. tol. and standard) :

✧ *self-biased feedback diode (improved gain)*

✧ *reset diode (improved gain)*

Amplifier schematics (3): improved common source + continuously biased from feedback (self-biased)

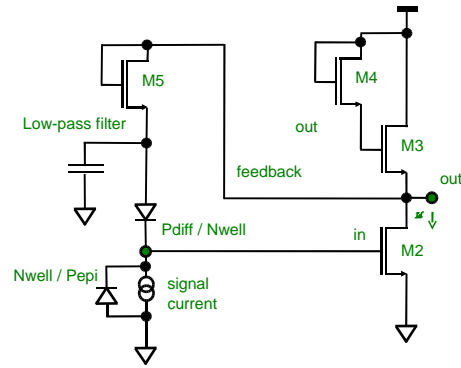

France

A. Dorokhov, IPHC, Strasbourg,

Amplifier schematics (4): improved common source + reset from feedback (time-variant feedback)

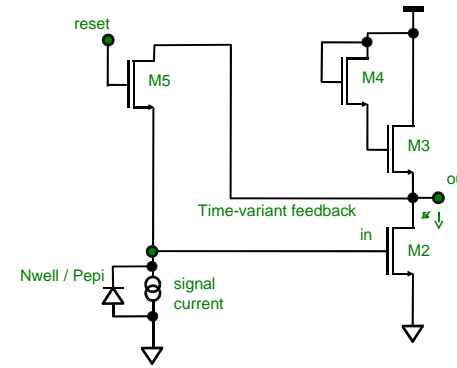

France

A. Dorokhov, IPHC, Strasbourg,

## Main results obtained with exposure to $^{55}\text{Fe}$ source ( $t_{r.o.} = 92.5 \mu\text{s}$ ) :

✧ *Noise :*

≈ *Temporal (pixel) Noise*  $\sim 0.5 - 0.7 \text{ mV}$  ( $10 < N < 14 e^- \text{ ENC}$ )

≈ *FPN*  $\sim 0.25 \text{ mV}$

≈ *N (rad. tol. pixels)*  $\sim N$  (*standard pixels*)  $+ 1 e^- \text{ ENC}$

✧ *Cluster CCE :*

≈ *3x3 pixels* : 70 – 80 %

≈ *5x5 pixels* : 80 – 90 %

✧ *T dependence* ( $\sim 10^\circ - 35^\circ \text{ C}$ ) *quite marginal* :  $\lesssim 10\%$  *noise variation*

✧ *5 different chips characterised* : *identical performances within*  $\pm 5\%$

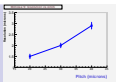

	S6		S7		S8		S9		S10	
	mV	e-	mV	e-	mV	e-	mV	e-	mV	e-
TN	0.612	11.5	0.601	10.7	0.615	11.3	0.595	10.0	0.639	11.6
FPN	0.250	4.7	0.263	4.6	0.254	4.4	0.273	4.6	0.222	4.0
	S12		S13		S15		S16		S17	
	mV	e-	mV	e-	mV	e-	mV	e-	mV	e-
TN	0.636	11.2	0.692	13.4	0.682	12.8	0.536	12.4	0.527	11.4
FPN	0.225	4.0	0.269	5.2	0.277	5.2	0.218	5.1	0.217	4.7

- Pixel Noise ~ 0.6mV
  - FPN ~ 0.25 mV
  - RadTol pixels (S6, S10, S13) Noise slightly higher than for standard pixels
- ⇒ Similar results than smaller prototype MIMOSA16 ones



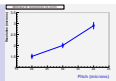

S12 response for 3, 5 and 7 mV threshold without and with <sup>55</sup>Fe source

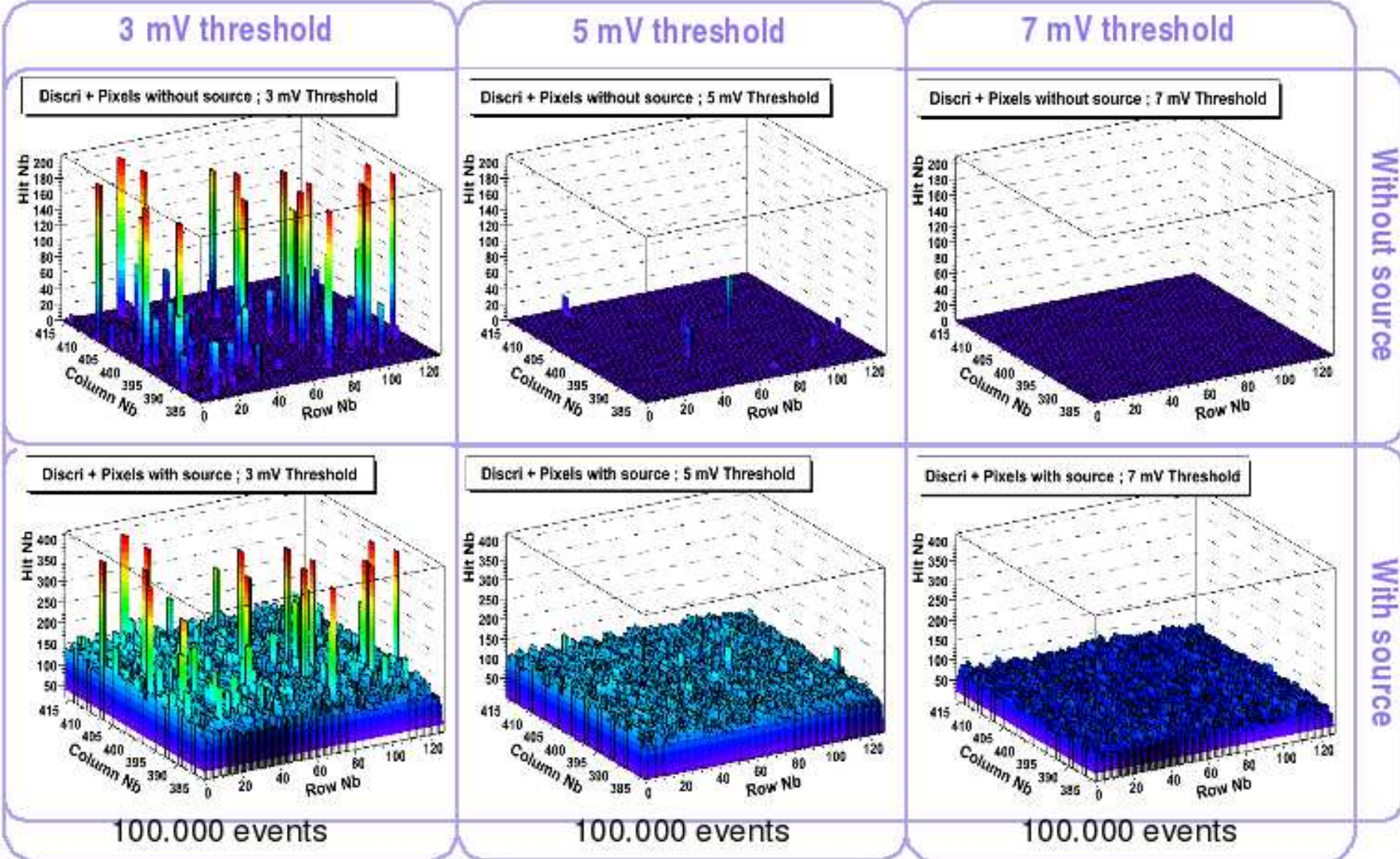

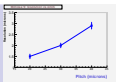

5 mV threshold with  $^{55}\text{Fe}$  source

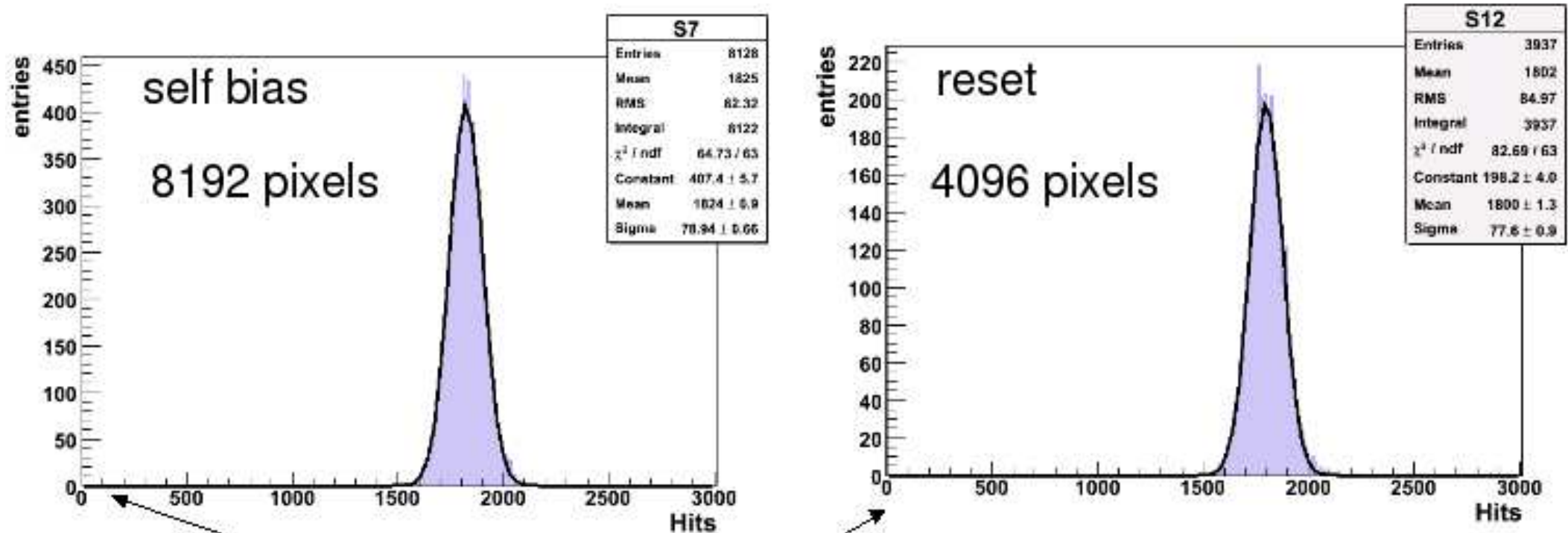

No dead pixel number

Good uniformity of discriminator response, within 4%

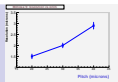

- about 2 weeks of beam time in August at CERN-SPS
- T4-H6 beam line :  $\sim 100 \text{ GeV } \pi^-$  beam
- MIMOSA-22 chip mounted on Si-strip telescope
- poor beam conditions  $\Rightarrow$  only 2 chips tested
- most of data collected with 1 (non-irradiated ) chip :  
6 different discriminator threshold values (2.1 – 6.6 mV )
- irradiated chip (150 kRad) only tested with 2 threshold values (3.1 & 4.2 mV )

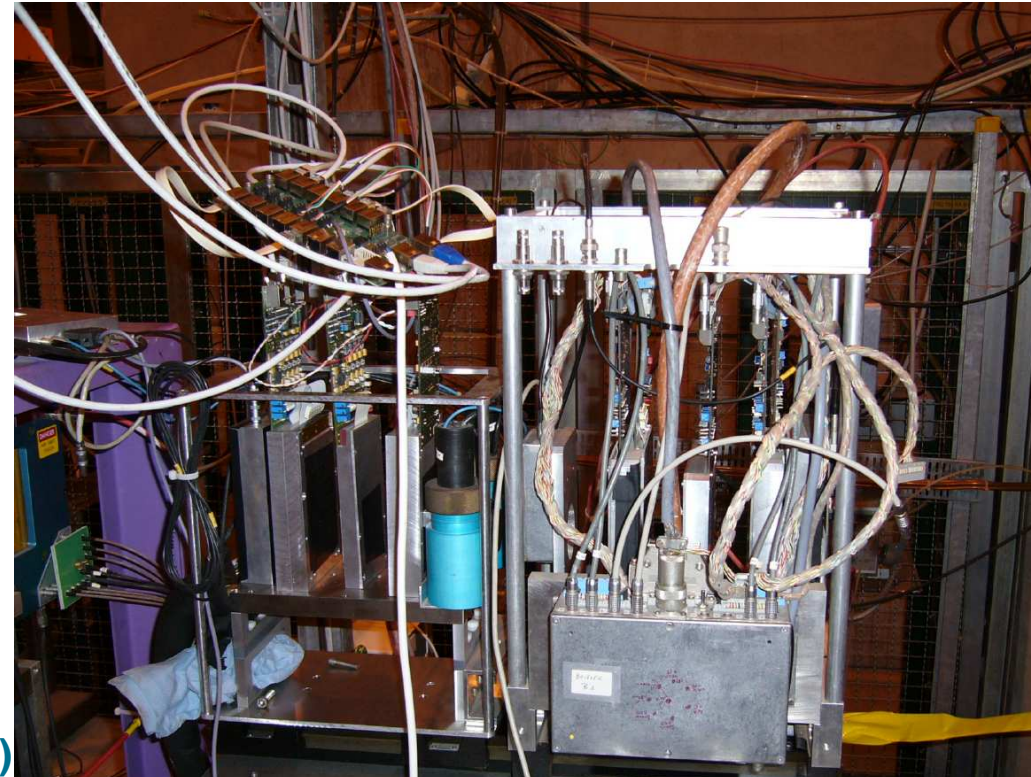

$\Rightarrow$  Data analysis still very preliminary !!!!

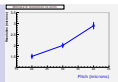

## Noise and S/N distributions delivered by the 8 columns without discriminator

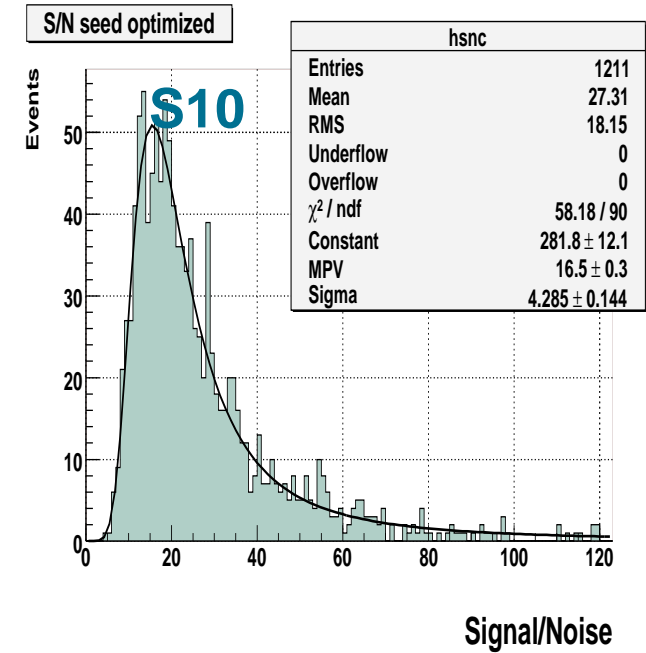
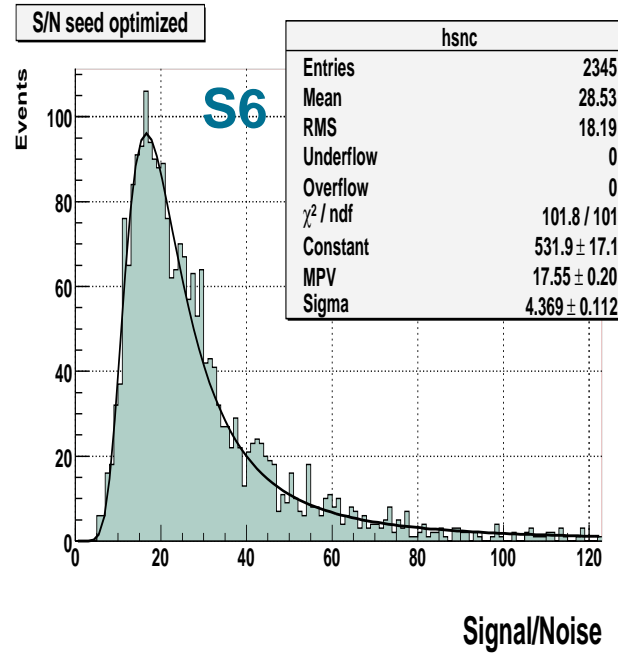
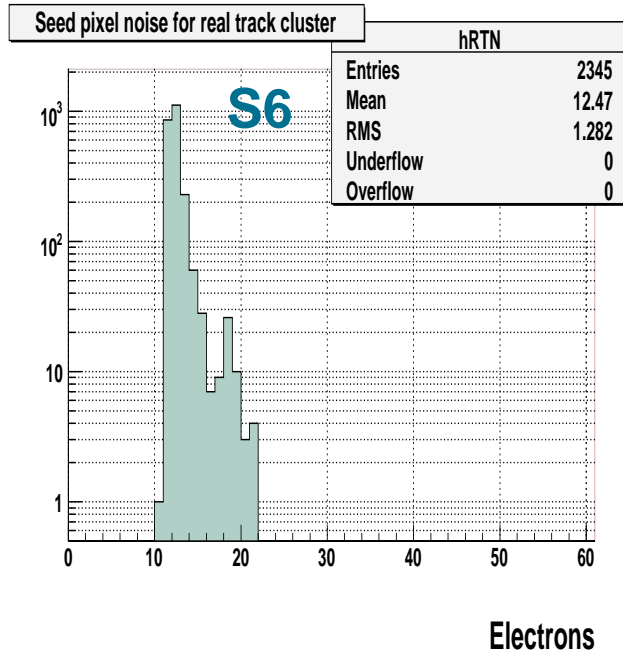

## Detection efficiency :

Sub-array	S6	S7	S10	S12	S13
Det. eff.	$99.91 \pm 0.06 \%$	$99.96 \pm 0.04 \%$	$99.83 \pm 0.12 \%$	$100.00 \pm 0.11 \%$	$100.00 \pm 0.10 \%$

✧ very satisfactory performances : det. eff.  $\sim 100 \%$  and single pt resolution  $< 1.5 \mu\text{m}$

⇒ pixel architecture (diode size, rad. tol. diode design, amplification scheme ) validated

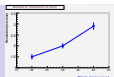

■ Det. efficiency, fake hit rate & single pt resolution for S6, S7, S12, S13 vs discri. threshold (prelim.) :

M22 digital S6. Efficiency, Fake rate and Resolution

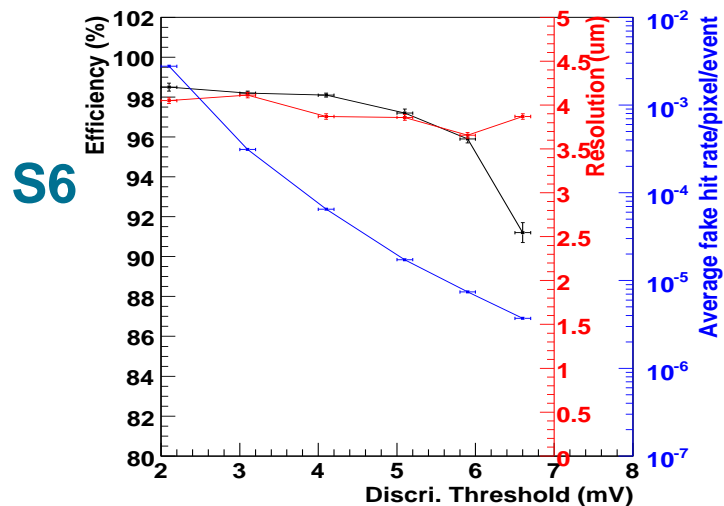

M22 digital S7. Efficiency, Fake rate and Resolution

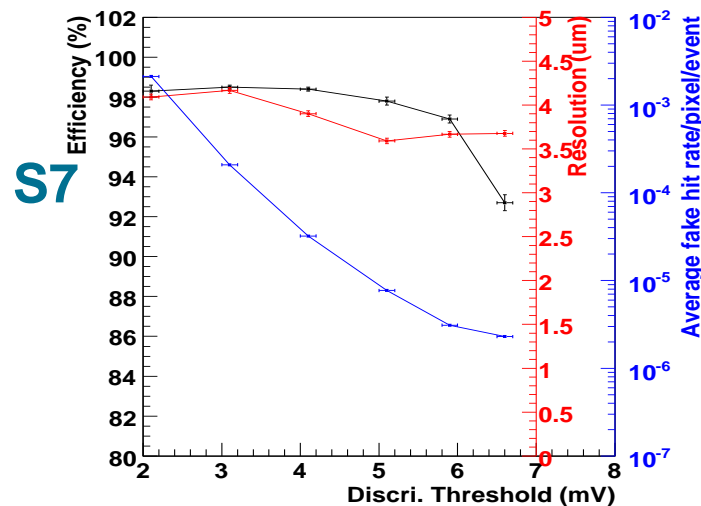

M22 digital S12. Efficiency, Fake rate and Resolution

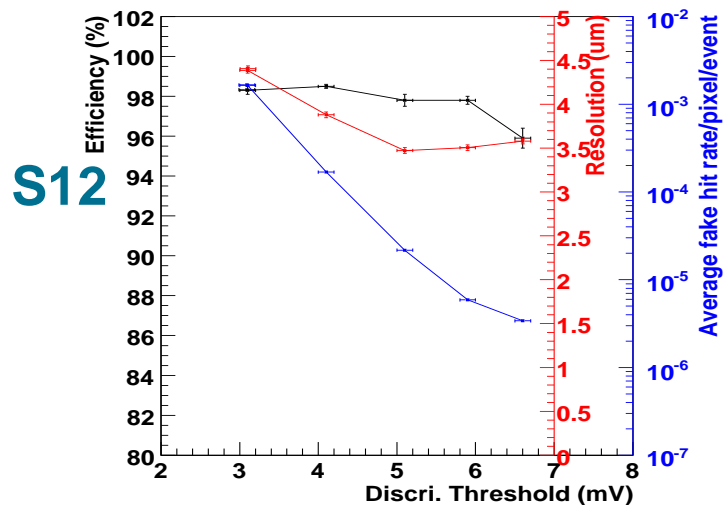

M22 digital S13. Efficiency, Fake rate and Resolution

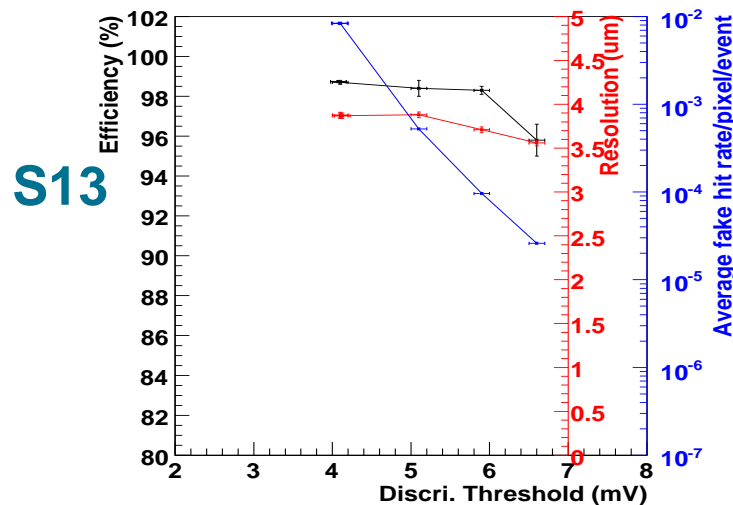

▷ ▷ ▷ Detection efficiency ~ 98.5 % for all (rad. tol. and standard ) pixel architectures !!!

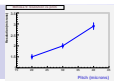

## Detection efficiency, fake hit rate & single pt resolution for S8, S9, S10 vs discri. threshold (prelim.) :

M22 digital S8. Efficiency, Fake rate and Resolution

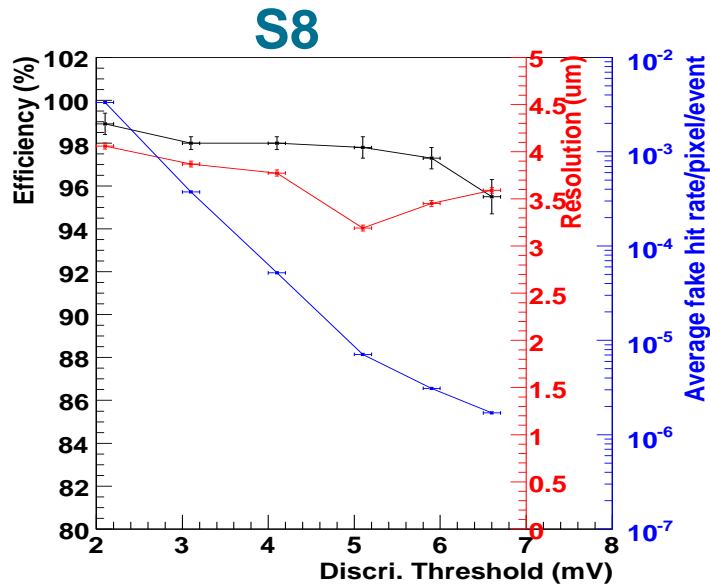

M22 digital S9. Efficiency, Fake rate and Resolution

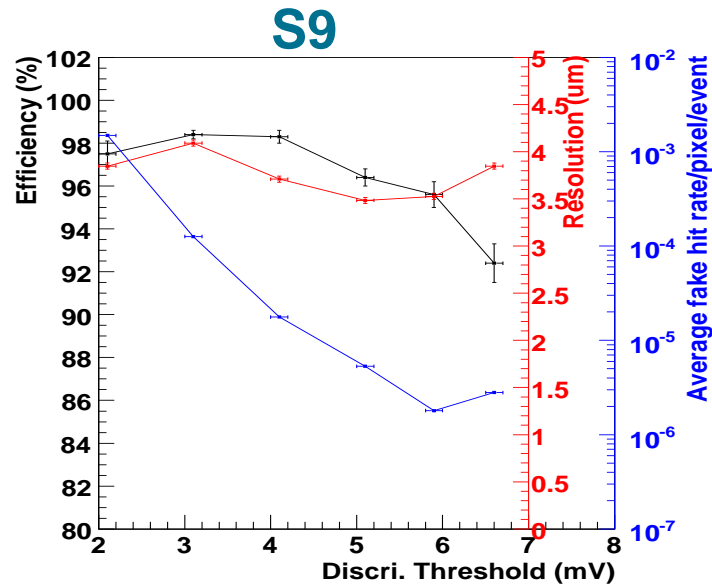

M22 digital S10. Efficiency, Fake rate and Resolution

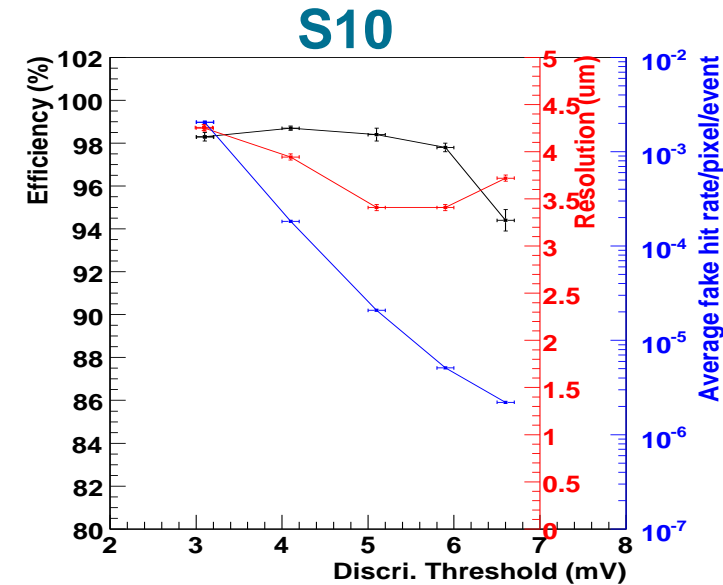

### Main (still preliminary ) results:

- ✧ *rather marginal performance differences between the 7 sub-arrays (e.g. rad. tol. vs standard)*
- ✧ *det. eff. of analog output  $\gtrsim 99.8\%$  for all sub-arrays  $\Rightarrow$  pixel architecture validated*
- ✧ *det. eff. of digital output  $\sim 98.5\%$  for all 7 sub-arrays (while MIMOSA-16 exhibits  $99.9\%$ )*  
*source of inefficiency probably in DAS event formatting  $\rightarrow$  partial re-analysis : det. eff. close to  $100\%$*
- ✧ *fake hit rate similar to MIMOSA-16 value and acceptable :  $O(10^{-4} - 10^{-5})$*
- ✧ *single point resolution  $\gtrsim 3.5\ \mu\text{m}$  (as expected)*
- ✧ *no performance non-uniformity observed over the chip surface  $\Rightarrow$  real scale check validated*

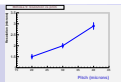

Comparison of det. efficiency & fake hit rate vs S/N for all sub-arrays (prelim.) :

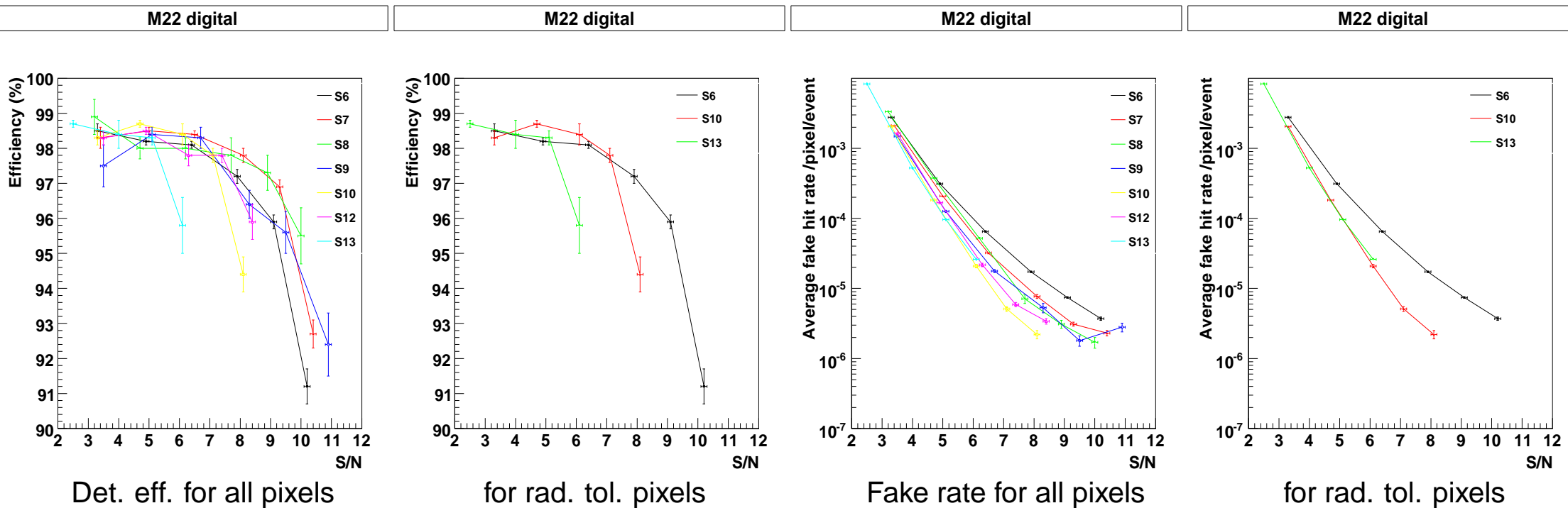

▷ Observed performance differences (& analysis maturity) don't allow yet deciding for a given pixel archi.

⇒ Wait for : \* MIMOSA-22bis performances \* more beam tests \* radiation tolerance studies

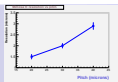

■ 1st chip (SDC-2/SUZE-01) with integrated  $\emptyset$  and output memories (no pixels) :

- ✧ 2 step, raw by raw, logic :
  - ◇ step-1 (inside blocks of 64 columns) :
    - identify up to 6 series of  $\leq 4$  neighbour pixels per raw
    - delivering signal  $>$  discriminator threshold
  - ◇ step-2 : read-out outcome of step-1 in all blocks
  - and keep up to 9 series of  $\leq 4$  neighbour pixels
- ✧ 4 output memories (512x16 bits) taken from AMS I.P. lib.
- ✧ surface  $\sim 3.9 \times 3.6 \text{ mm}^2$

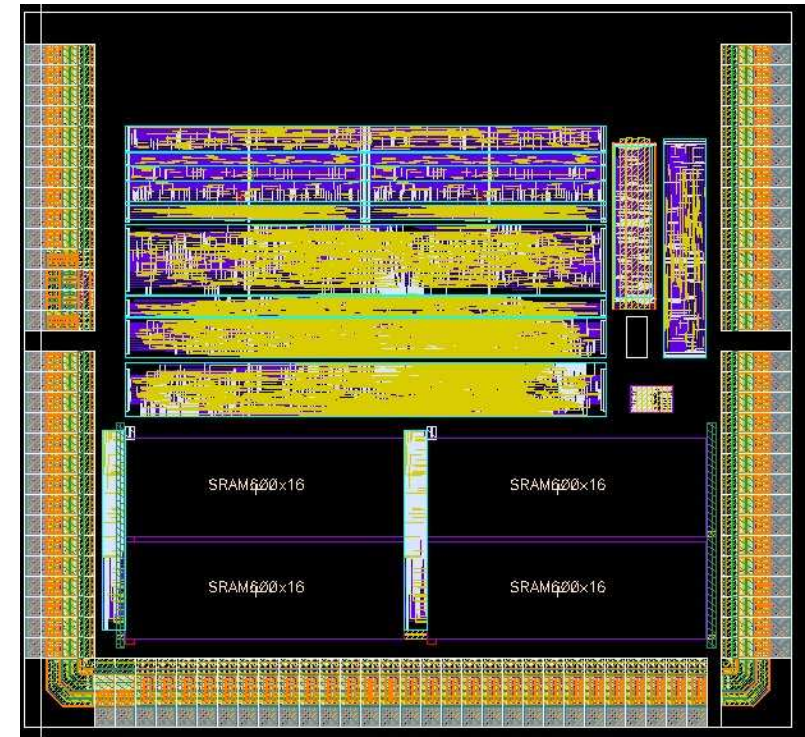

■ Test results summary :

- ✧ back from foundry end of Sept. '07  $\rightarrow$  (lab) tests completed
- ✧ design performances reproduced up to  $1.15 \times$  design read-out frequency ( $T_{room}$ ) :
  - noise values as predicted, no pattern encoding error, can handle  $> 100$  hits/frame at rate  $> 10^4$  frames/s

■ Still to do : evaluate radiation tolerance (latch-up) of output memories



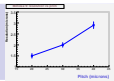

## Why may radiation tolerance be a concern ?

- \* max. annual doses at DESY  $\lesssim 10^{11} e^-$  (few GeV)/yr  $\Rightarrow \lesssim 3.5$  kRad &  $10^{10} n_{eq}/cm^2$
- \* max. annual doses at CERN  $\lesssim$  several  $10^{12} \pi^-$  ( $10^2$  GeV)/yr  $\Rightarrow \lesssim O(10^2)$  kRad &  $O(10^{12}) n_{eq}/cm^2$

## Assessing radiation tolerance (10 keV X-Rays):

### \* Noise of IDC/M-22 (S6):

- $\sim 12.5 e^-$  ENC before irradiation
- $\sim 17 e^-$  ENC after 150 kRad
- $\sim 22 e^-$  ENC after 300 kRad

### \* New design (MIMOSA-22bis) fabricated

▷ tests in Septembre (lab, SPS)

### \* MIMOSA-22 non-ionising radiation tolerance assessment under way with fluences of $3$ & $6 \cdot 10^{12} n_{eq}/cm^2$

### \* Latch-up & SEU tests of SDC-2/SUZE-01 foreseen in Septembre

M22 digital S6 (150kRad). Efficiency, Fake rate and Resolution

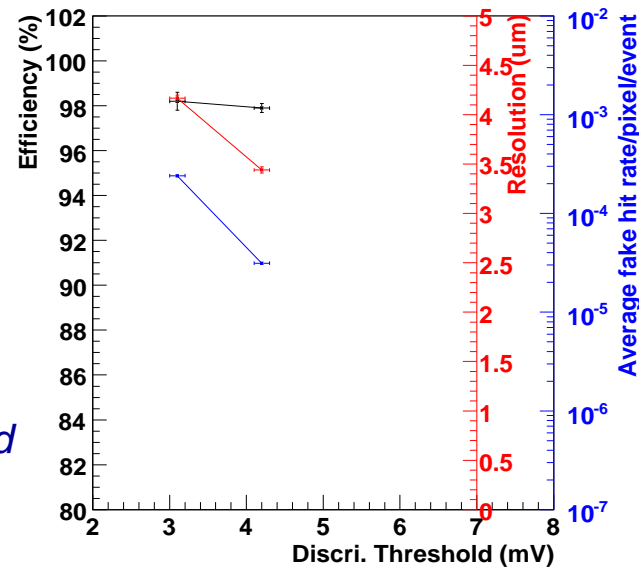

M22 digital S7 (150kRad). Efficiency, Fake rate and Resolution

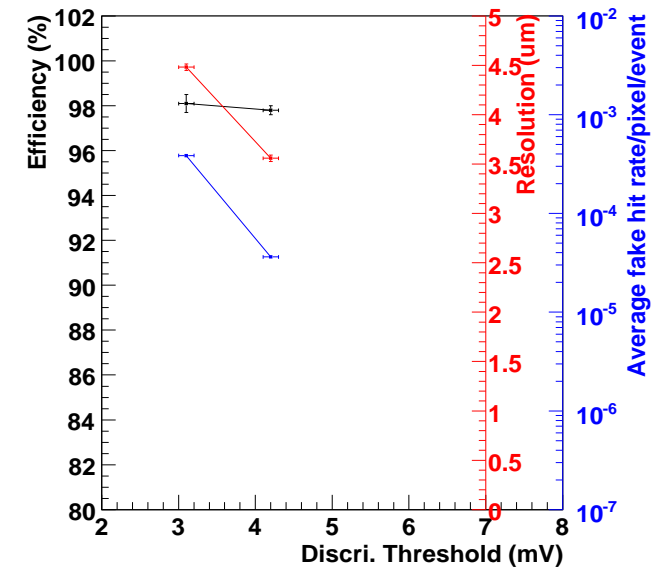



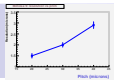

- Col. // architecture with discri. outputs validated for m.i.p. detection on real scale (128 col. of final length) :
  - ⇒ read-out frequency  $\sim 10^4$  frames/s ✓
  - ⇒ pixel noise  $\sim 11\text{--}13 e^- ENC \Rightarrow S/N \sim 17\text{--}19$  (MPV) ✓
  - ⇒  $\epsilon_{det} \sim 99.5\%$  (some checks missing) with fake rate  $\sim O(10^{-4} - 10^{-5})$ , like MIMOSA-16 ✓
  - ⇒  $\sigma_{sp} \gtrsim 3.5 \mu m \Rightarrow$  resolution on impact position on DUT surface  $\lesssim 2 \mu m$  ✓
  
- $\emptyset$   $\mu$ -circuit with output buffers validated for 128 col. at read-out frequency  $>$  nominal value ✓
  
- Radiation tolerance :
  - ⇒ still a concern for use of telescope (copies ?) at CERN, FermiLab, ...
  - ⇒ improved pixels under development
  - ⇒ SEU / latch-up tests of output memories in preparation (to be done in Septembre)
  
- ⇒ TC  $\equiv$  final sensor (combining col. // architecture with  $\emptyset$   $\mu$ -circuit) :
  - ⇒ design under way (crucial issue : extension from 128 to 1152 col. of IDS combined with SDC-2 )
  - ⇒ in absence of unexpected pb, submission should take place  $\gtrsim$  mid-Novembre '08
  - ↪ TC sensor tests expected to start in January 2009