

Progress on the CMS Tracker control system

F. Drouhin¹, K. Gill², L. Gross³, R. Grabit², K. Kloukinas², C. Ljuslin², G. Magazzu², A. Marchioro², E. Murer², E. Noah², C. Paillard², J. Troska², F. Vasey² and D. Vintache³

¹Universite de Haute-Alsace, Mulhouse, France

²CERN, 1211 Geneva 23, Switzerland

³Institut de Recherches Subatomiques de Strasbourg, France

karl.gill@cern.ch

Abstract

The recent progress on the CMS Tracker control system is reviewed, with a report of activities and results related to ongoing parts production, integration and system testing, as well as controls software development. The integration of final parts into Tracker systems and the subsequent testing is described taking the Tracker Outer Barrel as an example application.

I. INTRODUCTION

The CMS Tracker control system is used to configure and operate the CMS Tracker front-end electronics and readout system. In each of the 4 control/DAQ partitions (TIB/TID, TOB, TEC+ and TEC-) the control system is broken down into ‘control rings’[1] which are the basic elements of the control system. There are 350 rings in total for the Tracker. The same (or similar) control system is also used elsewhere in CMS: Pixels (64 rings), ECAL (368 rings), Preshower (52 rings), RPC (28 rings) and TOTEM (12 rings).

A control ring is illustrated in Fig. 1. The Front-end Controller card (abbreviated as FEC/CCS) is located in the counting room. Clock, trigger and resynchronization signals from the TTC system are sent around the ring on the ‘clock’ line at 80Mbit/s. Control signals are communicated over the ‘data’ channel at 40Mbit/s in NRZI format with 4 to 5 bit encoding. The digital optohybrid module (DOHM) makes the conversion between optical and electrical signals and LVDS used to transfer signals around the subsequent chain of communication and control unit modules (CCUMs). There is a redundant path throughout the entire ring which allows reconfiguration to bypass a failed CCUM (though if adjacent CCUMs fail then the ring will be lost).

The control ring operates with a ‘token-ring’ architecture: in the idle state a ‘token’ circulates around the ring. When a node (the FEC/CCS or one of the CCUs) wishes to talk, the node removes the token and replaces it with a data packet. When an acknowledge signal is received, the transmitting element releases the token again to circulate around the ring ready for the next transmission of data. CCUs that are being addressed in a given control command decode the signals and relay them as I²C transactions to/from the front-end ICs (APV, PLL, DCU, LLD, APV-MUX) that are mounted on the front-end hybrids (FEH) and optohybrids (analogue AOH and

digital DOH). Hard resets are also transmitted on the data line of the control ring: a sequence of 20 ‘zero’ bits will trigger the RX40 IC on the DOH to generate a reset pulse that is sent to the CCUs around the ring, and from these to the various ICs on the FEH, AOH and DOH.

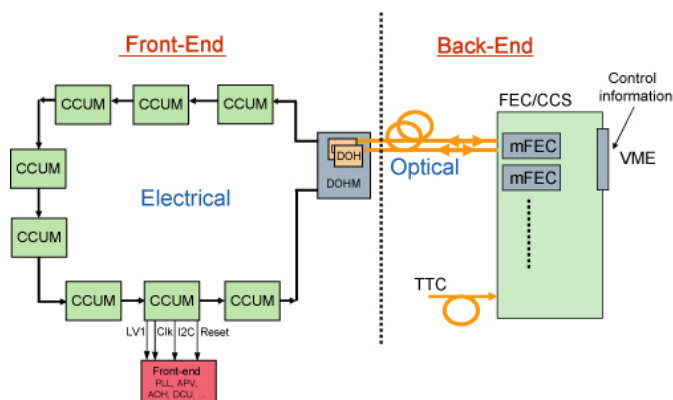

Figure 1: A control ring in the CMS Tracker control system.

The different component parts, firmware and software in the control system are in various states of production and integration, with QA/QC tests made at all levels from the components up to the full control system. The remainder of the paper reviews the status of the various activities on the control system, and then considers also the integration of the control system taking the CMS Tracker Outer Barrel (TOB) as an example application.

II. STATUS OF THE COMPONENTS

A. FEC/CCS[2]

Off-detector optical mezzanine front-end controller cards (mFEC) to populate the 9U FEC/CCS cards have been developed and tested at CERN. Around 1000 mFECs, one per control ring and including ~10% spares, are foreseen for the whole of CMS. The mFEC shown in Fig. 2(a) can be mounted either on the FEC/CCS or on a PCI card. A purely electrical version of the mFEC (with no optical transceiver TRx) has also been designed for test-system applications as well as a portable USB-interfaced FEC for rapid system debugging.

The FEC/CCS shown in Fig. 2(b) hosts up to 8mFECs. It is now ready for final production after validation of the

version-3 pre-production boards. The card has been tested successfully in a VME 64x crate utilizing a bridge with a LINUX PC running the XDAQ software. It has been fully populated with 8 mFECs and tests were carried out on the VME-local bus interface, fast timing path, as well as monitoring of the temperature of the optical TRxs. The power consumption of a fully populated card was 30W.

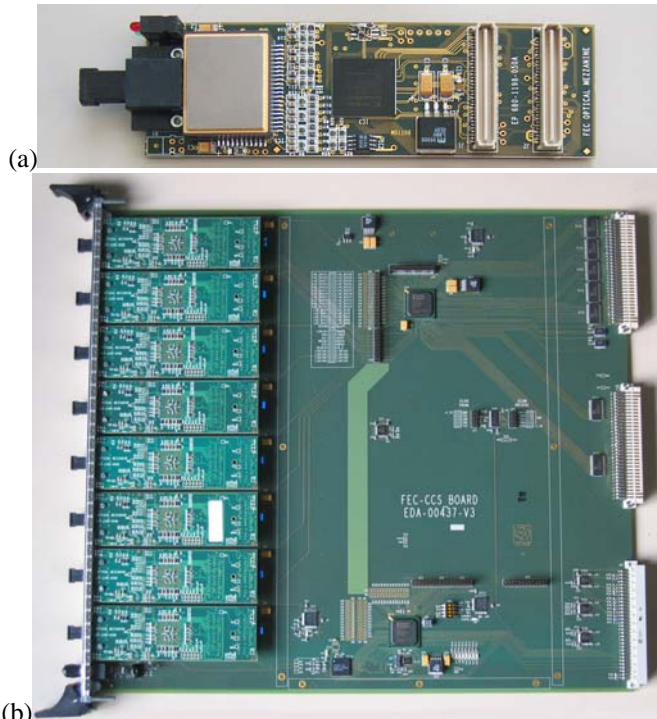

Fig. 2: (a) mFEC optical mezzanine FEC card and (b) the 9U FEC/CCS that can carry 8mFECs and drive 8 control rings.

A total of 15 out of 20 prototype FEC/CCS boards (using 91 optical mFECs) are already in use in system tests in the different sub-detector integration or test centres. The mFECs will be re-used as spares, if needed for the final systems. The Tracker requires 44 FEC/CCS. A total of 130 (+20 spare) final boards that will be made and delivered to CERN by the end of 2005.

Considering possible problems of obsolescence, the TRx and FPGAs are the most likely sub-components to become obsolete during the lifetime of the cards. An additional 10% FPGAs have therefore been ordered. (The TRx is considered in the following sub-section.) All the other parts are still expected to be commercially available for some time.

B. Optical links[3]

The digital optical links shown in Fig. 3 are based on COTS parts re-using wherever possible the same components and suppliers as for the much larger analogue optical link system for readout of the CMS Tracker. The same lasers, fibres, cables and connectors are used. The same suppliers are used for the DOH as for a large fraction of the analogue optohybrids for the Tracker (as well as the GOH for the

ECAL). Likewise the supplier of the backend transceiver (TRx) modules is the same one supplying related parts to Tracker and ECAL.

The use of the various COTS parts (lasers, fibre, photodiodes, DOH hybrid and its sub-components) has mandated a rigorous QA/QC programme, including extensive testing of radiation hardness and reliability of all front-end parts. This work was completed in 2004 and much of it has been reported in previous Workshops. The QA programme has also included functional lot acceptance tests (typically 5-10% sampling) at CERN during production/assembly. This allows a cross-check (and usually some tests at a deeper level) of the 100% testing of functionality of each component by the manufacturer. All test data and reports have been archived in EDMS[4], and the test data for fibres, lasers and DOH are also stored in Tracker Production Database.

The few custom parts in the links include the rad-tolerant laser driver LLD and receiver RX40 ICs designed by the CERN MIC group and manufactured using a 0.25um process. A sufficient number of chips were tested for correct functionality (radiation hardness was also checked previously) and only known good die have been mounted onto DOHs.

Very few faulty optical link parts and assemblies have been delivered to CERN during production. The main problems (e.g. related to handling of the fragile lasers and photodiodes) were resolved during pre-production. More notably a recent batch of 100 TRx was reworked to reduce the tightness of the optical correction. Also, some chipping of the ceramic in the optical head of the TRx had occurred in some parts. This damage was investigated thoroughly by the supplier with the conclusion that it was limited to being an aesthetic defect and the module performance and reliability was not affected. Several hundred TRx have been mounted onto mFECs, some now in use in test-systems and integration systems, without any reported failures or breakages.

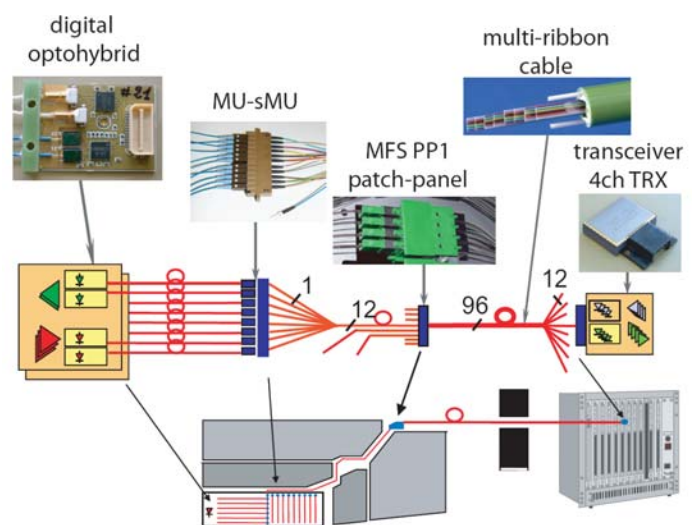

Fig. 3: CMS Tracker digital optical control links.

Very few DOH were non-functional, only about 1.5%. On these devices, the problem had usually already been seen by the supplier but the device was sent to CERN in any case for further diagnosis. Most of the defects are consistent with cold solder joints and the devices have been returned to the supplier for repair. Many buffer ruptures in the optical fibres were found, typically one cut on a fibre on ~5% of DOH for those DOH having lasers and photodiodes that use acrylate coated fibre. This is a known problem that can occur through a manufacturing defect, poor handling, or during heat treatment such as curing of the epoxies. Buffer rupture is not necessarily a serious problem – often only an aesthetic defect and not affecting the functionality of the DOH. However, the fibre buffer provides additional torsional rigidity to the fibre therefore all the buffer ruptures found on DOH have been repaired with flexible epoxy (tested to be rad-resistant). Finally, only known-good DOHs have been delivered to the users. To date only two DOH have been broken during integration. A reserve of ~10% spares has been accumulated to cover eventual replacement of failed or broken DOHs that cannot be repaired.

Component obsolescence has been a serious concern, in particular for the TRx. The original transmitter and receiver ICs already became obsolete and the half of the TRx production used different ICs that dissipate more power. The modified TRx was re-qualified to confirm that it retained its specified performance. Also, the production line for the TRx modules will close in 2005. A conservative approach to spares was therefore necessary and 20% additional TRx have been ordered - a quarter of which are being used in test-systems, though all of these parts are potentially recoverable as spares for the final system should the need arise.

In summary, the production of the various optical link parts is going well. It is behind the original schedule though this has not impacted the users. Quality and assembly yield has been excellent with no significant wastage. A reasonable spares policy has been decided and implemented and the production of optical control links components will soon be complete.

C. Control ring test system

A test-system was built at CERN, shown in Fig. 4, that allows extensive testing of the full control ring including the redundancy scheme. The test system is fully configurable such that the number of CCUMs can be adjusted, as well as the associated cable lengths and topology (e.g. to include dummy CCUMs which are needed in certain cases to complete the redundancy scheme).

Up to 17 CCUMs have been included in the ring under test. For comparison, the TIB/TID subdetector in the Tracker has the most CCUM nodes in one ring, with up to 16. The eventual failure of any given CCUM, or associated element can be simulated and studied, and the susceptibility of the control ring to noise can also be studied in detail.

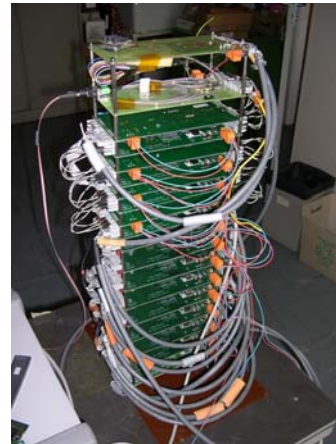

Fig. 4: Control ring test system. Shown here is a control ring with 17 CCUMs connected (with redundancy) using different types and lengths of interconnect cable, to simulate different possible configurations. The optical interface contain the DOHs is at the top of the stack.

The performance of the control system with up to 10 TOB-type CCUMs in the ring has also been studied, with the front-end parts exposed to temperatures between ambient room temperature and -30C, which is below the intended operating temperature of the Tracker. The control system worked well, with a very low rate of transaction errors.

D. Software

The architecture of the software for the control system is illustrated in Figs. 5 and 6, at the level of the control rings and then at the level of surrounding diagnostic system respectively. The software has been described in some detail previously[5] and the current status is summarized here. The control software essentially consists of 3 systems: Database, Configuration, and Diagnostics.

The database contains all the parameters needed for the configuration of the Tracker such as: FEC/CCS VME slot, Ring, CCU address, Channel on the CCU, I²C address of the device, and finally the parameters for each register of the front-end devices together with a versioning system. The database is a pure relational model implemented using the Oracle database management system. The complete configuration of the Tracker requires ~1680000 parameters per version. It is estimated that the entire Tracker could be configured in less than one minute, although the subsequent upload time is expected to be longer and dependent upon any error conditions observed.

Several dedicated layers of code pilot the FEC/CCSs, enabling the configuration and operation of the front-end electronics on and around the detector modules. The first layer is able to access the FEC/CCS VME card through a PCI to VME interface. The original software in this layer was intended as a Linux device driver able to drive either an electrical or optical PCI FEC. The second layer manages the control ring and the way in which the front-end ICs are accessed and configured through the I²C bus. A third layer

manages the eight rings on a single FEC/CCS board and the fourth layer is the high level *FecSupervisor* that is integrated in the overall framework of the CMS experiment using XDAQ[6]. The *FecSupervisor* manages two kinds of operations handled by the FEC:

- Download: this operation consists of retrieval of all the values needed from the database and download of these values to the front-end devices
- Upload: after the download is done the *FecSupervisor* retrieves the values from the front-end, makes a comparison and uploads any errors into the database. The error are also signalled to the general diagnostic system.

The *FecSupervisor* is also able to receive messages from the calibration procedures in order to determine the optimum configuration parameters, e.g. the timing delays at the PLLs, gain and bias of the laserdriver (LLD), etc. The DCU Filter collects the environment and electrical bias data from the DCUs at the front-end. Finally, the *FecSupervisor* also responds to errors in the ring e.g. wrongly configured parameters, ring ‘lost’, or single event upset (SEU) in front-end configuration registers. It is able to switch between the primary and backup control path in the control ring redundancy scheme.

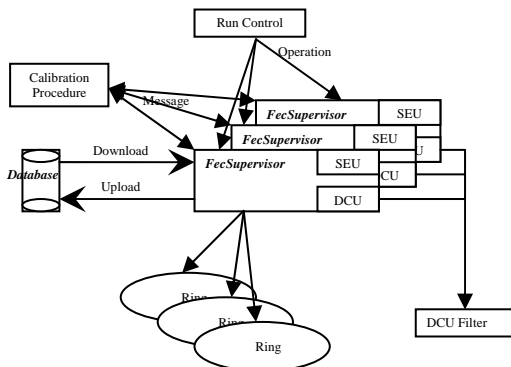

Fig. 5: Software architecture for the Tracker control system

At the level of the diagnostic system, shown in Fig. 6, errors are reported from the *FecSupervisor* (or *FEDSupervisor*, *TriggerSupervisor*, or *Filter Unit*) to the diagnostic system, which is able to diagnose the error(s) and possibly recover the system. Typically two kinds of errors exist in this system, either ‘local’ or ‘global’:

- Local error: having two main types, hardware error or software error. For example in the FEC sub-system, the hardware errors could be:
 - Problem in configuring a register in a front-end device (e.g. no power, or faulty device),
 - Problem in the ring (e.g. faulty CCU, no power on the ring)
 - SEU phenomena

The software errors include for example, network problems or bad connection to the database, etc. All local errors are detected by the process itself, ie. the *FecSupervisor* for the control system.

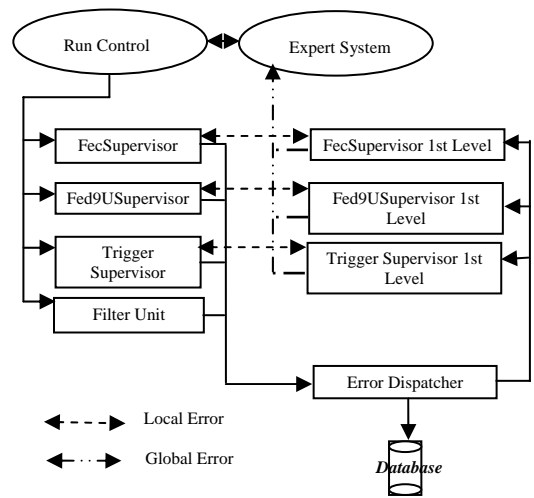

Fig. 6: Diagnostic system to handle error conditions.

- Global error: this is when an error has been detected by a sub-system but the problem typically comes from another sub-system. Some examples include:
 - Token ring open, i.e. ‘lost’ detected by the *FecSupervisor* that could be due to a fault in the powering system
 - Bad data detected by the readout system that could be due to a problem in configuration of the front-end devices
 - Temperature too hot in the Tracker that is detected through the control system (*FecSupervisor* with the DCU readout) that could be due to a fault in the cooling system

When an error occurs in the system, a message is sent to the error dispatcher that stores the information in a database and forwards the error to the first level of the diagnostic system (ie. *FecSupervisor* 1st level, etc.). This first level will diagnose and attempt to solve the problem. If the error cannot be solved at this level, it will be recognized and treated as a global error that will then be managed by the expert system. This part of the diagnostic system remains to be defined. Programmable criteria will be used to decide how the expert system will respond to global errors, based on the impact on the quality or safety of operation of the Tracker when faced with a given error or set of error conditions.

In summary, the design and implementation of the full range of control software is complete up to the diagnostic system where development is still ongoing. In particular there remains the definition of the expert system, its criteria for intervention and responses to different global errors.

III. INTEGRATION OF THE CONTROL SYSTEM

The control system for the Tracker Outer Barrel (TOB) will be considered now in more detail as an example application. Figure 7 shows schematically the arrangement used at CERN for ‘long-term’ testing of a control ring that includes a TOB ‘rod’, where the rod is the basic element of the TOB, on which the silicon modules and various hybrids are mounted.

The objectives of these tests were to verify the correct functionality and robustness of the control system in the TOB. The test-bed served also as a test-platform for the controls software. Finally, the test setup also has been used to validate the new TOB interconnect cards (ICC) that were re-designed in order to solve a weakness in I²C signal transmissions along the rods that was found during the first rod acceptance tests at low temperature.

The test procedure involved a continuous loop over the sequence of operations required to configure (and then read back) all the ICs of the rod under test. The download and upload cycle of all the parameters for this particular rod (SS6 type – single-sided sensors, with 6 APV ICs per front-end hybrid FEH) required 690 and 876 I²C transactions respectively, involving the transfer of 5942 and 6567 data bytes on the control ring in total. Eventual errors were flagged by the FEC and then logged and counted by the diagnostic system. Debugging tools recorded the contents of the registers of the FEC and CCU following any transaction that contained an error.

The long term tests have altogether accumulated ~780000 download/upload configuration cycles on the rod under test (at room temperature), with each cycle taking ~1.8s. No errors occurred at the level of the I²C transactions between the CCUs and the other front-end ICs on the front-end hybrids and optohybrids. However some errors were observed on the control ring, in 22 transactions out of 1.2x10⁹. All of these errors are currently under investigation to fully understand their origins. To put these results into perspective, there were ~1E13 bits transmitted on the data line during these long-term tests so the bit-error-rate is as low as specified for the system (1E-12). Moreover, the tests were equivalent to the configuration of the entire TOB 1000 times, so the control system is therefore considered to be robust.

IV. CONCLUSION

The progress on the control system used for the CMS Tracker has been reported. The same control system is also used by various other systems including CMS ECAL, Preshower, RPC, Pixels, and TOTEM. The procurement of all of the main components is close to complete, in line with the needs for hardware integration. The quality of the parts delivered has been very good and few problems have been reported by users. A spares policy has been established with at least 10% spare parts throughout the control system. The software to pilot and monitor the control system is complete at the level of the front-end configuration and for a large part of the diagnostics. The development of the expert system to manage global errors is ongoing. Integration of the control system into the user-systems is going well. The Tracker Outer Barrel (TOB) was considered here as an example application and a TOB rod control system test-bed has been used to validate the robustness of the control system.

V. REFERENCES

- [1] "The control system for the CMS Tracker front-end", F. Drouhin et al., IEEE Trans. Nucl. Sci., Vol. 49, No. 3 (2002), pp. 846-850.
- [2] FEC/CCS Project web-site: proj-fec-ccs.web.cern.ch/proj-FEC-CCS
- [3] Optical links web-site: www.cern.ch/cms-tk-opto
- [4] EDMS the Engineering Data Management Service at CERN: edms.cern.ch
- [5] "The CERN CMS Silicon Strip Tracker Control System", F. Drouhin et al., CMS CR2004-032.
- [6] XDAQ platform for the development of distributed data acquisition system: <http://xdaq.web.cern.ch/xdaq/>

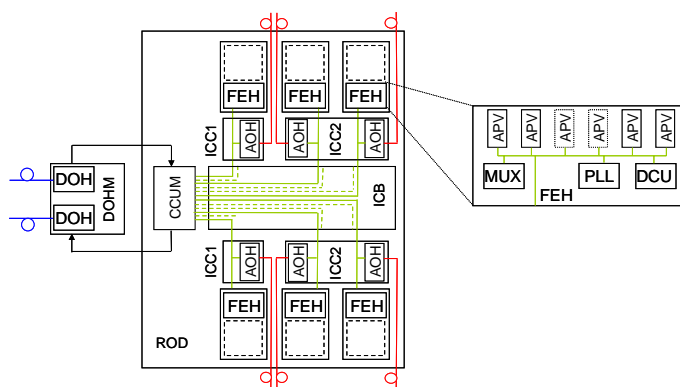

Fig. 7: Schematic layout and connections between hardware in the TOB-rod control test setup.