

Scintillation + Photo Detection

◆ Inorganic scintillators

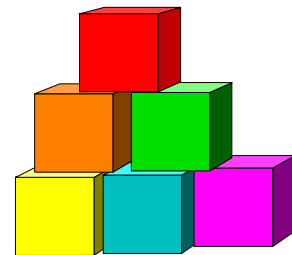

◆ Organic scintillators



◆ Geometries and readout

◆ Fiber tracking

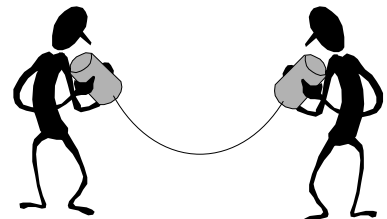

◆ Photo detectors

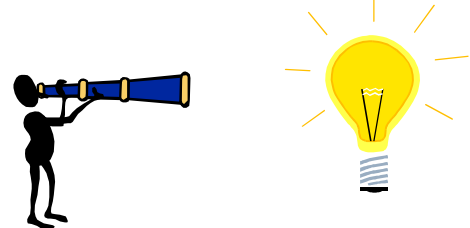

Scintillation

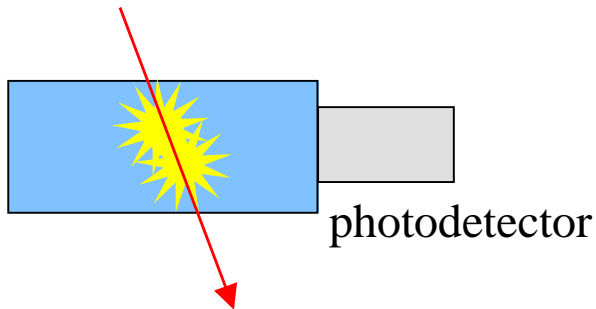

Energy deposition by ionizing particle
→ production of scintillation light (luminescence)

Scintillators are multi purpose detectors

- ☞ calorimetry
- ☞ time of flight measurement
- ☞ tracking detector (fibers)
- ☞ trigger counter
- ☞ veto counter

.....

Two material types: Inorganic and organic scintillators

high light output
but slow

lower light output
but fast

Three different scintillation mechanisms:

1a. Inorganic crystalline scintillators (NaI, CsI, BaF₂...)

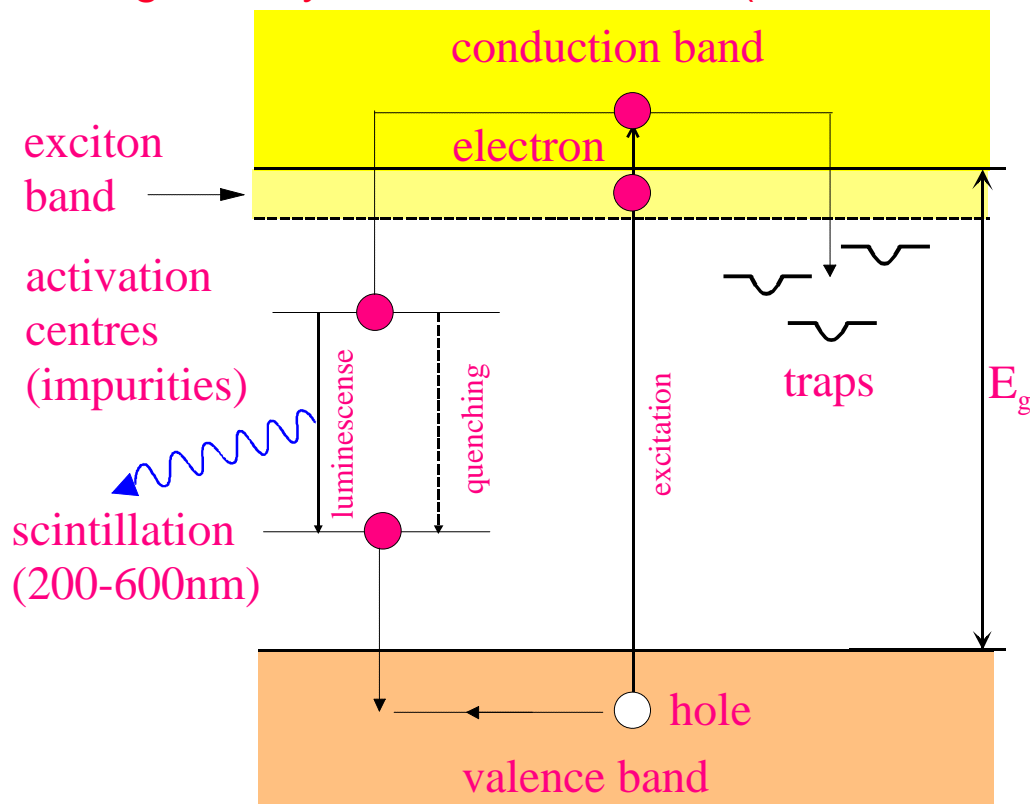

often ≥ 2 time constants:

- fast recombination (ns- μ s) from activation centre
- delayed recombination due to trapping (≈ 100 ms)

Due to the high density and high Z inorganic scintillator are well suited for detection of charged particles, but also of γ .

Light output of inorganic crystals shows strong temperature dependence

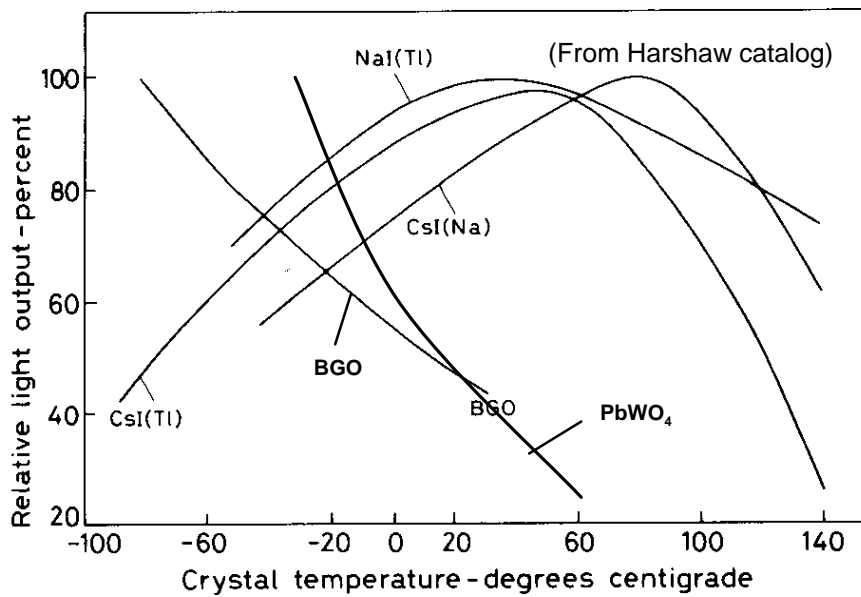

1b. Liquid noble gases (LAr, LXe, LKr)

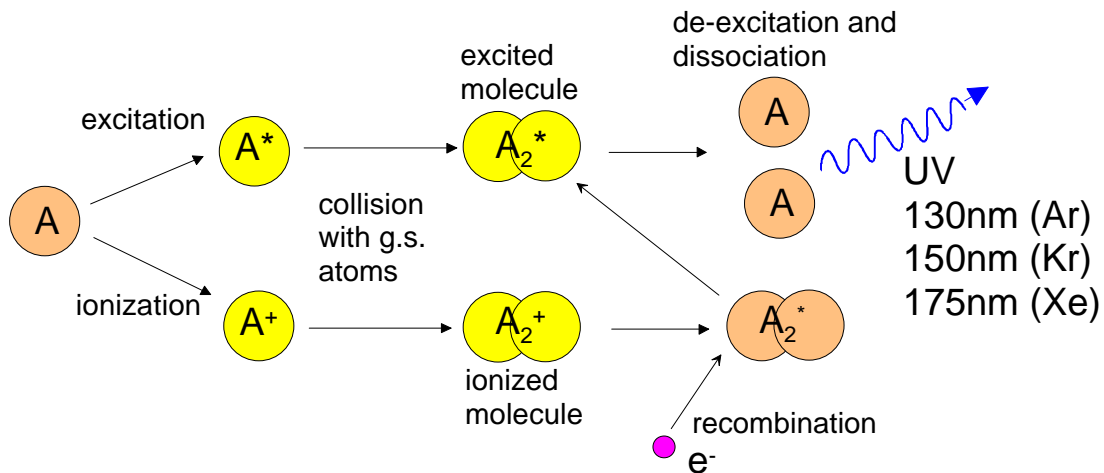

also here one finds 2 time constants: few ns and 100-1000 ns, but same wavelength.

Properties of some inorganic scintillators

Table A6.2 Properties of some inorganic scintillators

scintillator composition	density (g/cm ³)	index of refraction	wavelength of maximum emission (nm)	decay time constant (μs)	scintillation pulse height ¹⁾	notes	Photons/MeV
NaI	3.67	1.78	303	0.06	190	2)	4 × 10 ⁴
NaI(Tl)	3.67	1.85	410	0.25	100	3)	
CsI	4.51	1.80	310	0.01	6	3)	
CsI(Tl)	4.51	1.80	565	1.0	45	3)	1.1 × 10 ⁴
CaI(Na)	4.51	1.84	420	0.63	85	3)	
KI(Tl)	3.13	1.71	410	0.24/2.5	24	3)	
⁶ LiI(Eu)	4.06	1.96	470-485	1.4	35	3)	1.4 × 10 ⁴
CaF ₂ (Eu)	3.19	1.44	435	0.9	50		
BaF ₂	4.88	1.49	190/220 310	0.0006 0.63	5 15		6.5 × 10 ³ 2 × 10 ³
Bi ₄ Ge ₃ O ₁₂	7.13	2.15	480	0.30	10		2.8 × 10 ³
CaWO ₄	6.12	1.92	430	0.5/20	50		
ZnWO ₄	7.87	2.2	480	5.0	26		
CdWO ₄	7.90	2.3	540	5.0	40		
CsF	4.65	1.48	390	0.005	5	3)	
CeF ₃	6.16	1.68	300 340	0.005 0.020	5		
ZnS(Ag)	4.09	2.35	450	0.2	150	4)	
GSO	6.71	1.9	440	0.060	20		
ZnO(Ga)	5.61	2.02	385	0.0004	40	4)	
YSO	4.45	1.8	420	0.035	50		
YAP	5.50	1.9	370	0.030	40		

¹⁾ relative to NaI(Tl) ²⁾ at 80 K ³⁾ hygroscopic ⁴⁾ polycrystalline

PbWO ₄	8.28	1.82	440, 530	0.01			100
-------------------	------	------	----------	------	--	--	-----

LAr	1.4	1.29 ⁵⁾	120-170	0.005 / 0.860			
LKr	2.41	1.40 ⁵⁾	120-170	0.002 / 0.085			
LXe	3.06	1.60 ⁵⁾	120-170	0.003 / 0.022			4 × 10 ⁴

⁵⁾ at 170 nm

2. Organic scintillators: Monocrystals or liquids or plastic solutions

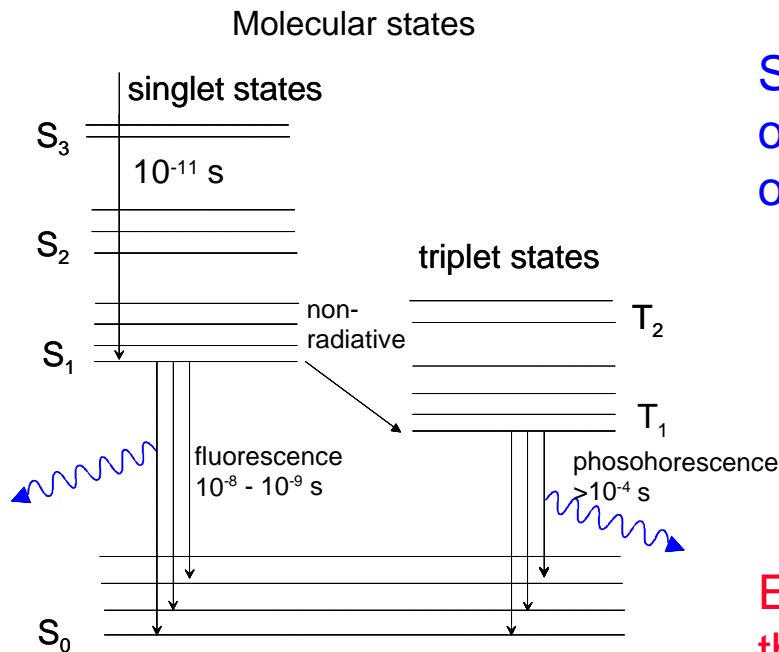

Scintillation is based on the 2 π electrons of the C-C bonds.

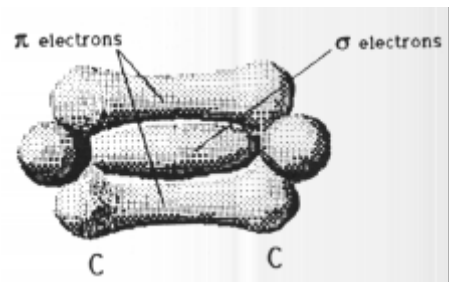

Emitted light is in the UV range.

Monocrystals: naphthalene, anthracene, p-terphenyl....

Liquid and plastic scintillators

They consist normally of a solvent + secondary (and tertiary) fluors as wavelength shifters.

Fast energy transfer via non-radiative dipole-dipole interactions (**Förster transfer**).

→ shift emission to longer wavelengths

→ longer absorption length and efficient read-out device

Schematic representation of wave length shifting principle

(C. Zorn, Instrumentation In High Energy Physics, World Scientific, 1992)

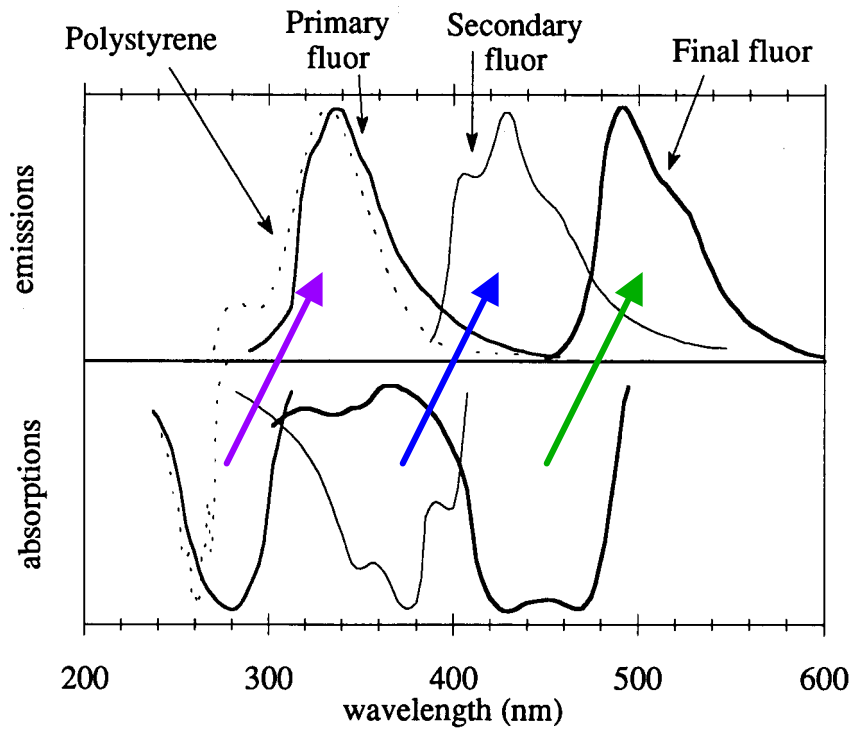

Some widely used solvents and solutes

	solvent	secondary fluor	tertiary fluor
Liquid scintillators	Benzene Toluene Xylene	p-terphenyl DPO PBD	POPOP BBO BPO
Plastic scintillators	Polyvinylbenzene Polyvinyltoluene Polystyrene	p-terphenyl DPO PBD	POPOP TBP BBO DPS

After mixing the components together plastic scintillators are produced by a complex polymerization method.

Some inorganic scintillators are dissolved in PMMA and polymerized (plexiglas).



Table A6.3 Properties of some organic scintillators

scintillator	density (g/cm ³)	index of refraction	wavelength of maximum emission (nm)	decay time constant (ns)	scintillation pulse height ¹⁾	H/C ratio ²⁾	yield/ NaI	
Monocrystals								
naphthalene	1.15	1.58	348	11	11	0.800	0.5	
anthracene	1.25	1.59	448	30-32	100	0.714		
trans-stilbene	1.16	1.58	384	3-8	46	0.857		
p-terphenyl	1.23		391	6-12	30	0.778		
Plastics ³⁾								
NE 102 A	1.032	1.58	425	2.5	65	1.105	0.5	
NE 104	1.032	1.58	405	1.8	68	1.100		
NE 110	1.032	1.58	437	3.3	60	1.105		
NE 111	1.032	1.58	370	1.7	55	1.096		
Plastics ⁴⁾								
BC-400	1.032	1.581	423	2.4	65	1.103		
BC-404	1.032	1.58	408	1.8	68	1.107		
BC-408	1.032	1.58	425	2.1	64	1.104		
BC-412	1.032	1.58	434	3.3	60	1.104		
BC-414	1.032	1.58	392	1.8	68	1.110		
BC-416	1.032	1.58	434	4.0	50	1.110		
BC-418	1.032	1.58	391	1.4	67	1.100		
BC-420	1.032	1.58	391	1.5	64	1.100		
BC-422	1.032	1.58	370	1.6	55	1.102		
BC-422Q	1.032	1.58	370	0.7	11	1.102		
BC-428	1.032	1.58	480	12.5	50	1.103		
BC-430	1.032	1.58	580	16.8	45	1.108		
BC-434	1.049	1.58	425	2.2	60	0.995		

¹⁾ relative to anthracene

²⁾ ratio of hydrogen to carbon atoms

³⁾ Nuclear Enterprises Ltd. Sighthill, Edinburgh, U.K.

⁴⁾ Bicon Corporation, Newbury, Ohio, USA

Organic scintillators have low Z (H,C). Low γ detection efficiency (practically only Compton effect). But high neutron detection efficiency via (n,p) reactions.

Scintillator readout

Readout has to be adapted to geometry and emission spectrum of scintillator.

Geometrical adaptation:

- ◆ Light guides: transfer by total internal reflection (+outer reflector)

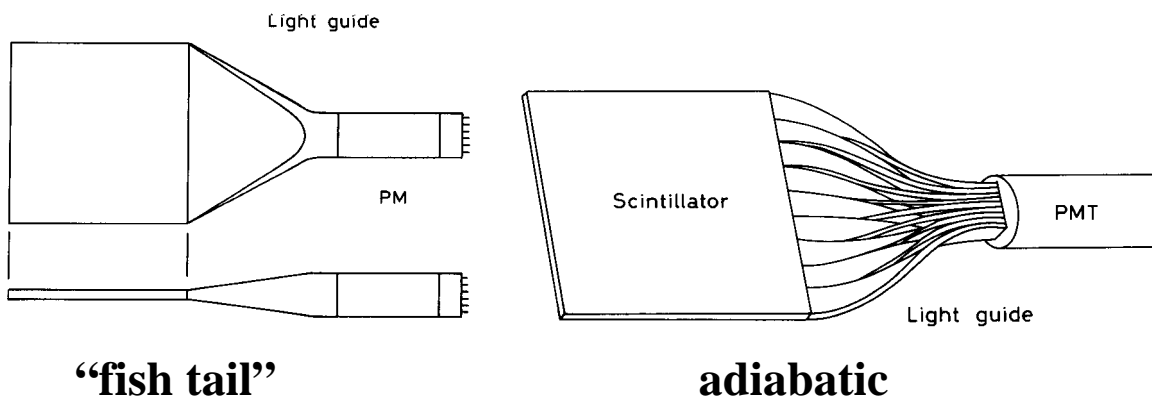

- ◆ wavelength shifter (WLS) bars

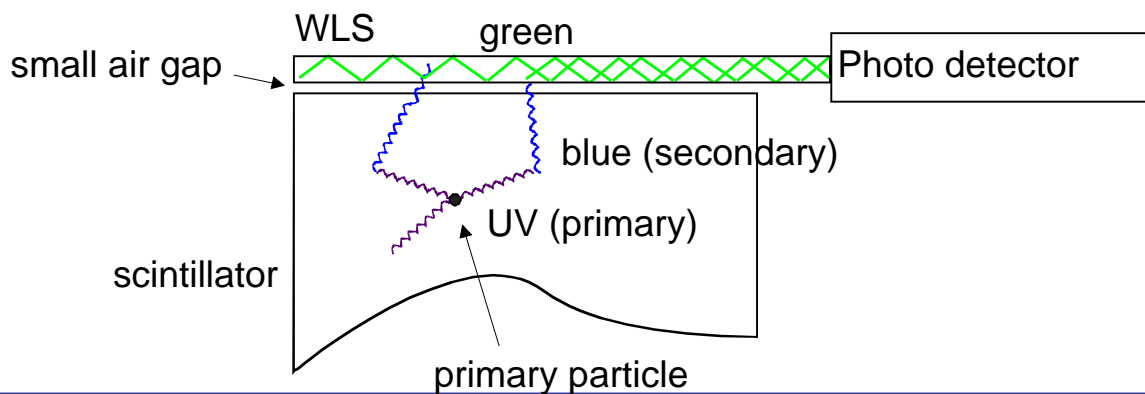

◆ Optical fibers

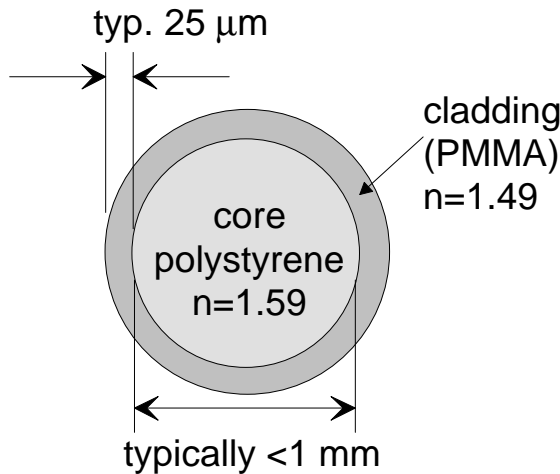

light transport by total internal reflection

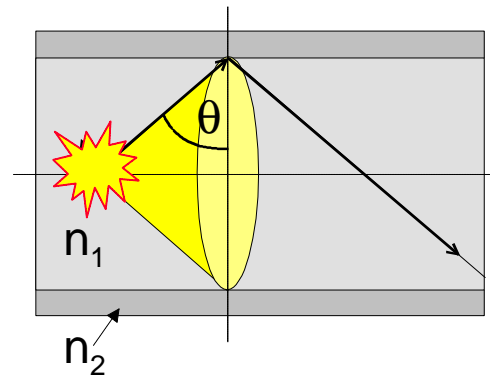

$$q \geq \arcsin \frac{n_2}{n_1} \approx 69.6^\circ$$

$$\frac{d\Omega}{4p} = 3.1\% \quad \text{in one direction}$$

minimize n_{cladding} .

Ideal: air ($n=1$), but impossible due to surface imperfections

multi-clad fibres
for improved
aperture

$$\frac{d\Omega}{4p} = 5.3\%$$

and absorption
length: $\lambda > 10 \text{ m}$ for
visible light

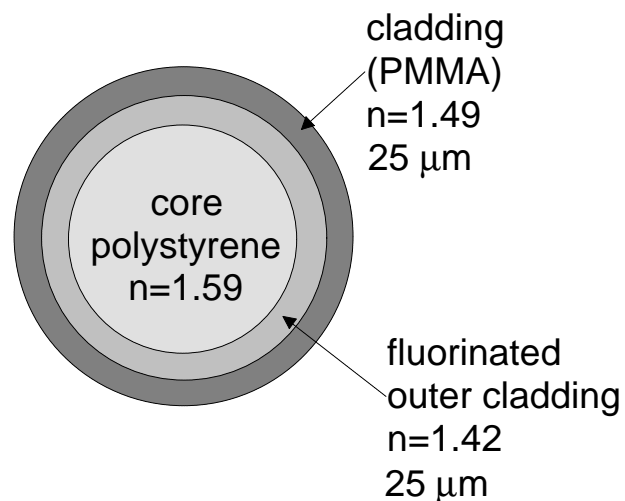

readout of a scintillator with a fiber (schematically)

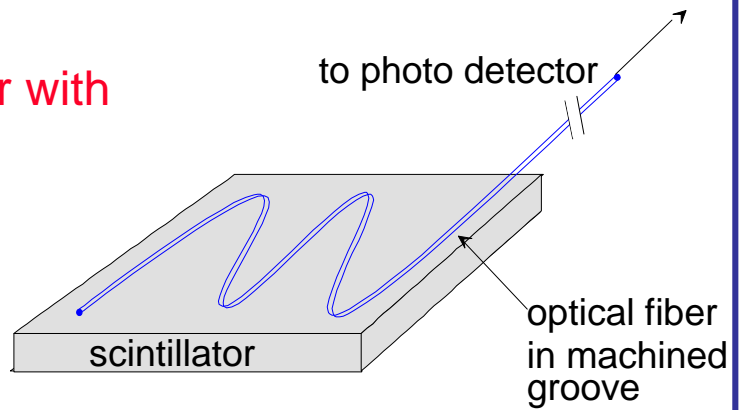

ATLAS Hadron Calorimeter:

(ATLAS TDR)

Scintillating tile readout via fibers and photomultipliers

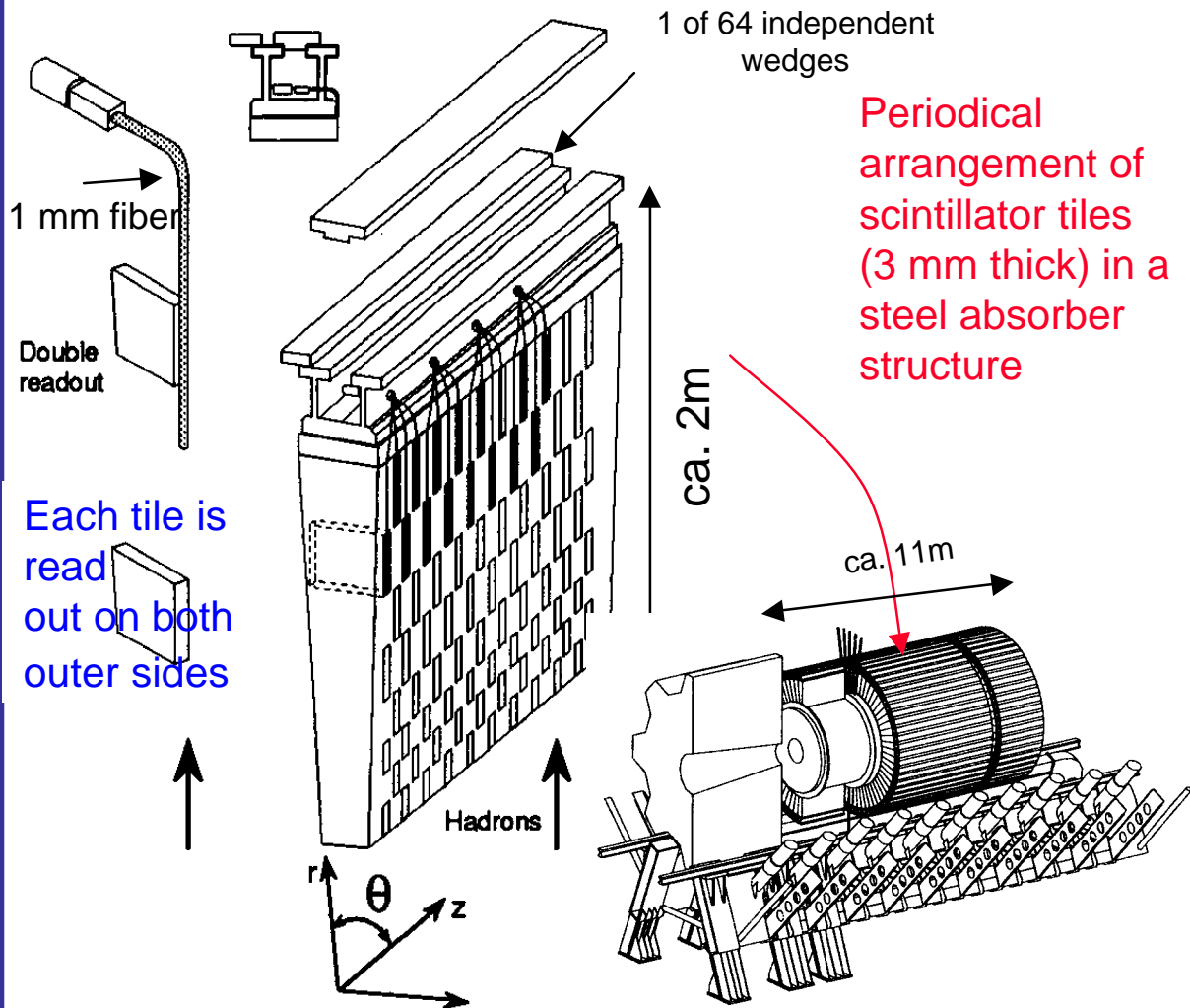

Scintillating fiber tracking

- ◆ Scintillating plastic fibers
- ◆ Capillary fibers, filled with liquid scintillator

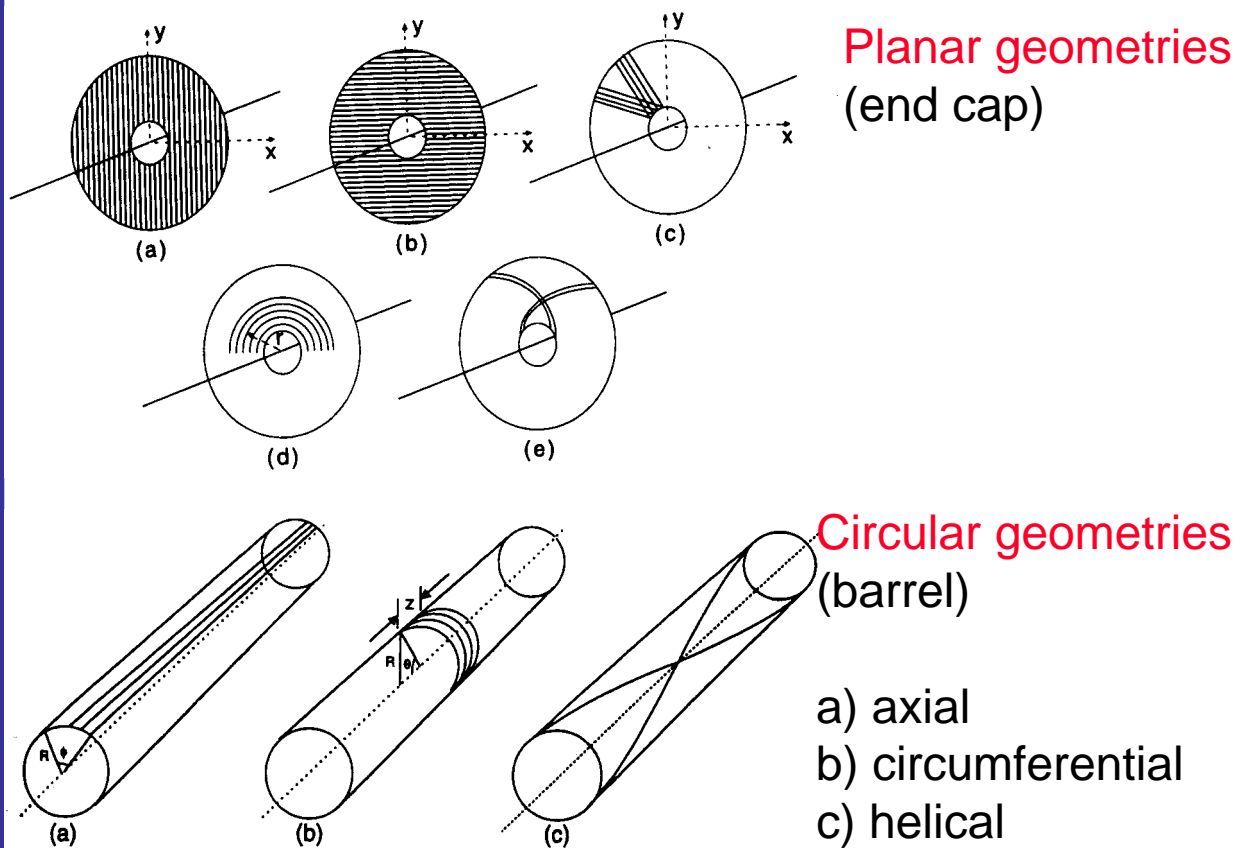

(R.C. Ruchti, Annu. Rev. Nucl. Sci. 1996, 46,281)

- High geometrical flexibility
- Fine granularity
- Low mass
- Fast response (ns) (if fast read out) → first level trigger

Charged particle
passing through a
stack of
scintillating fibers
(diam. 1mm)

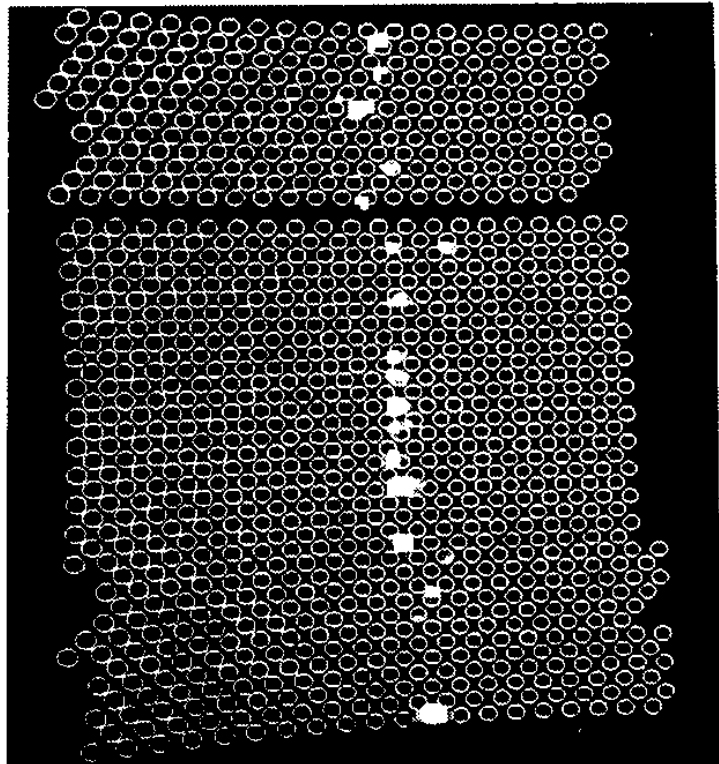

UA2 (?)

Hexagonal
fibers with
double cladding.

Only central
fiber illuminated.

Low cross talk !

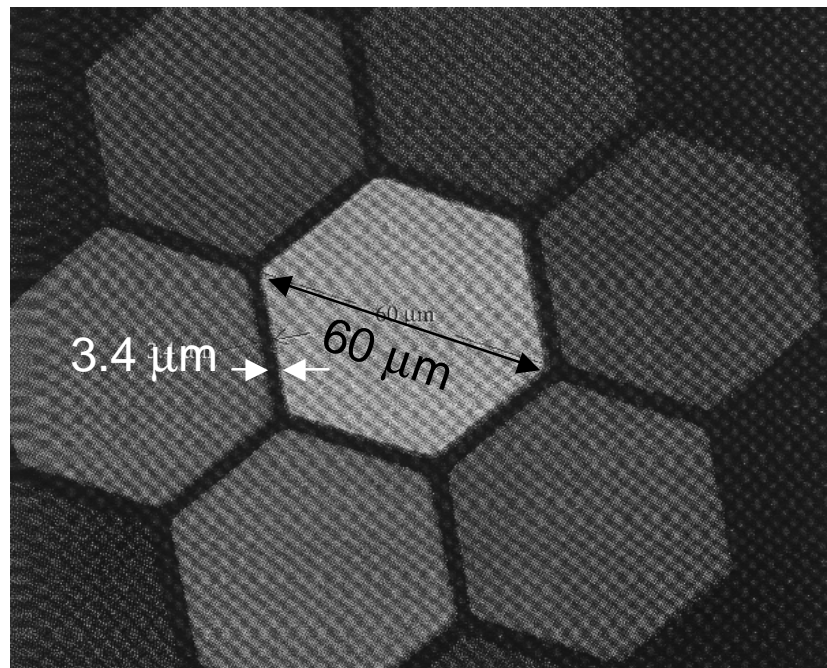

(H. Leutz, NIM A 364 (1995) 422)

Photo Detectors

Purpose: Convert light into detectable electronics signal

Principle: Use Photoelectric Effect to convert photons to photoelectrons

Threshold of some photosensitive material

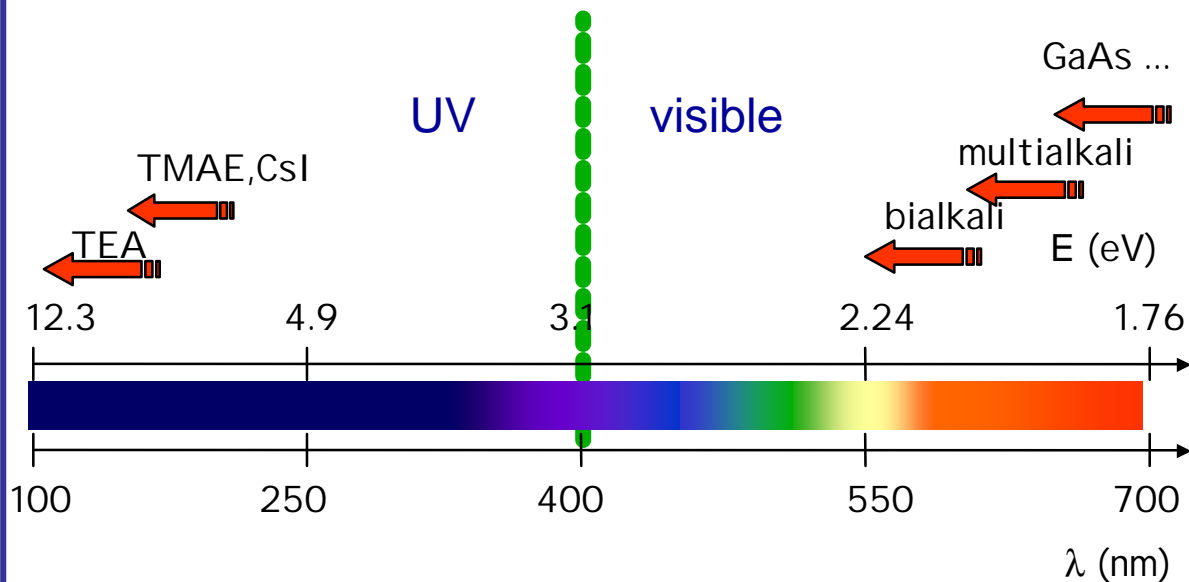

standard requirement

- high sensitivity, usually expressed as quantum efficiency $Q.E. = N_{p.e.} / N_{photons}$

Main types of photodetectors

- gas based devices (see RICH detectors)
- vacuum based devices
- solid state detectors

Quantum efficiencies of typical photo cathodes

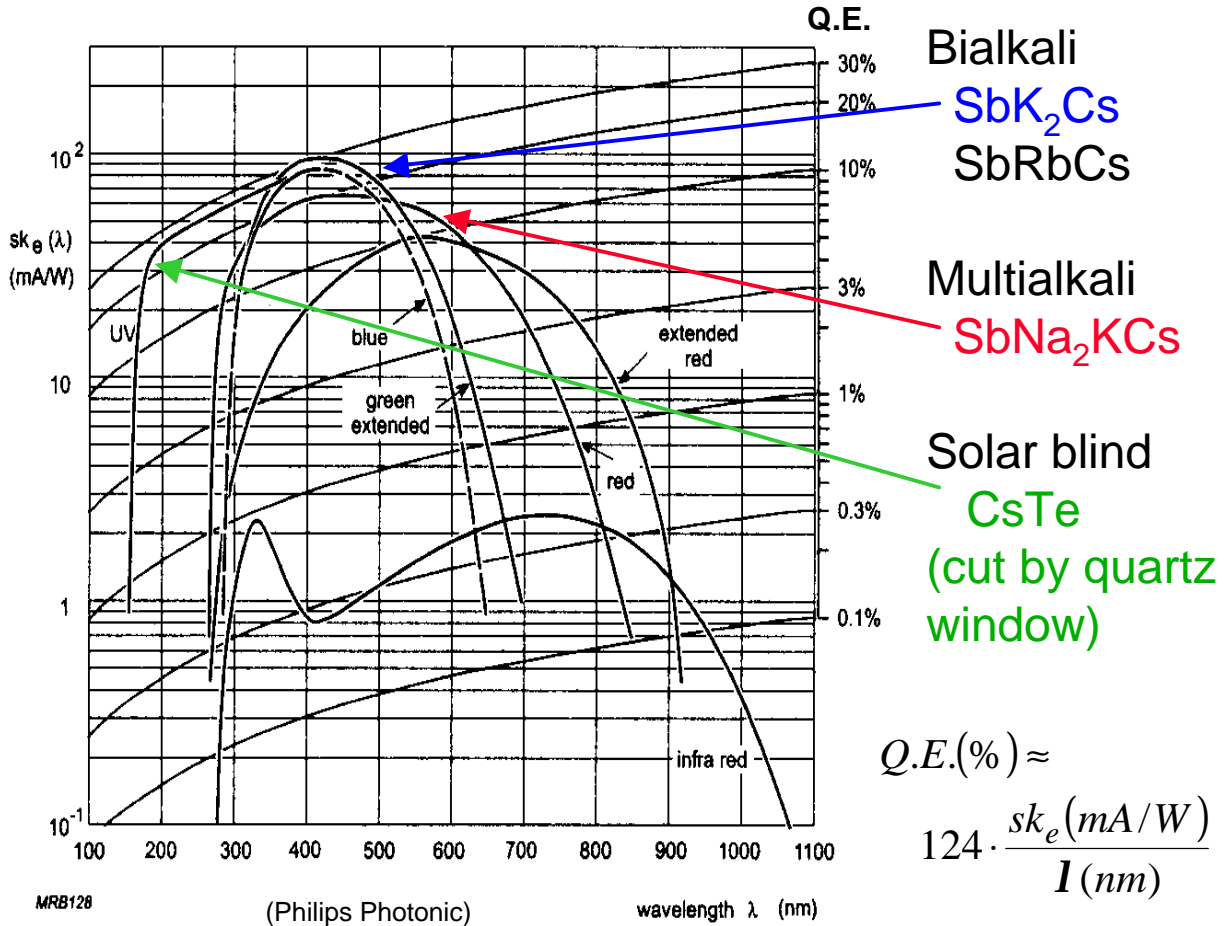

Transmission of various PM windows

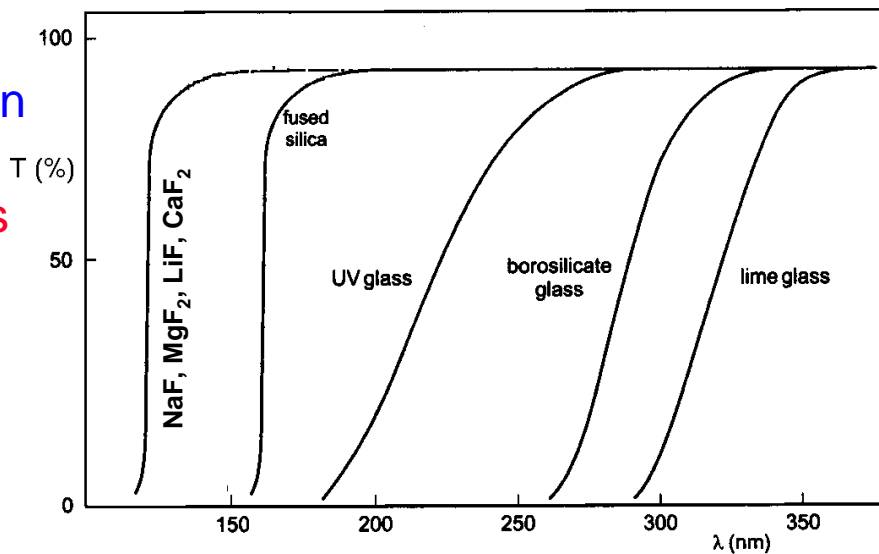
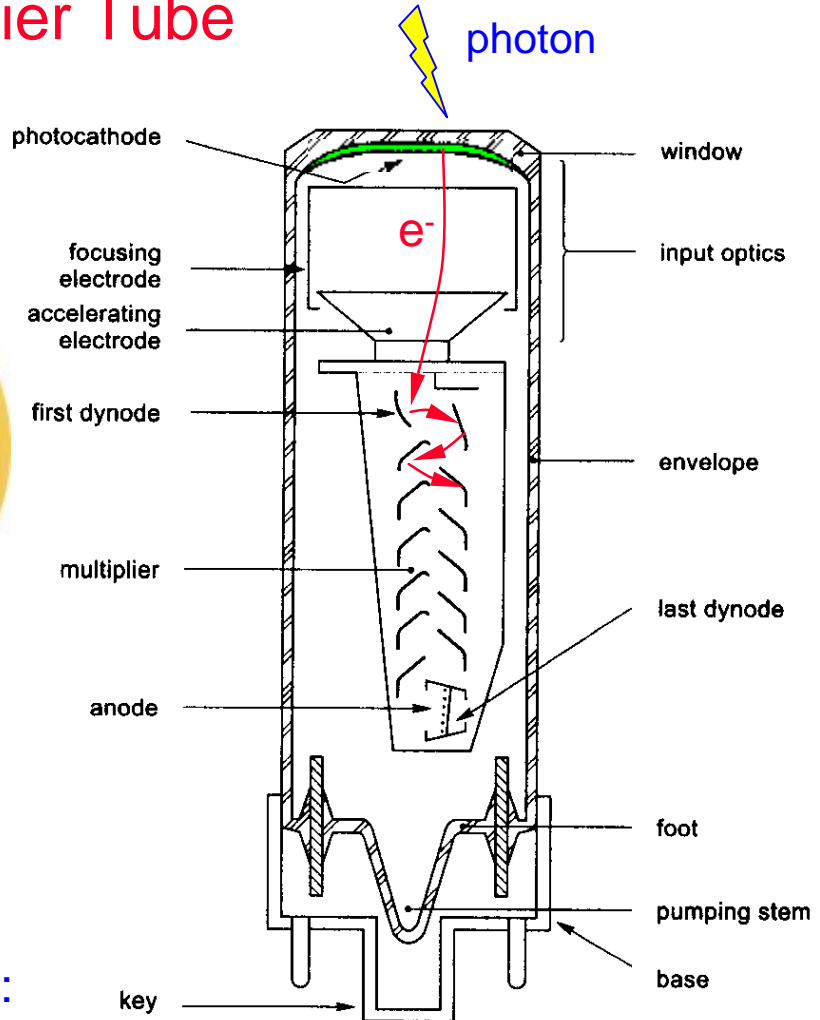

Photo Multiplier Tube (PMT)



(Philips Photonic)



main phenomena:

- photo emission from photo cathode.
- secondary emission from dynodes.

dynode gain $g=3-50$ ($f(E)$)

total gain $M = \prod_{i=1}^N g_i$

10 dynodes with $g=4$

$M = 4^{10} \approx 10^6$

PM's are in general very sensitive to B-fields, even to earth field (30-60 μ T). μ -metal shielding required.

◆ Energy resolution of PMT's

The energy resolution is determined mainly by the fluctuation of the number of secondary electrons emitted from the dynodes.

Poisson distribution:
$$P(\bar{n}, m) = \frac{\bar{n}^m e^{-\bar{n}}}{m!}$$

Relative fluctuation:
$$\frac{s_n}{\bar{n}} = \frac{\sqrt{\bar{n}}}{\bar{n}} = \frac{1}{\sqrt{\bar{n}}}$$

Fluctuations biggest, when \bar{n} small ! → First dynode !

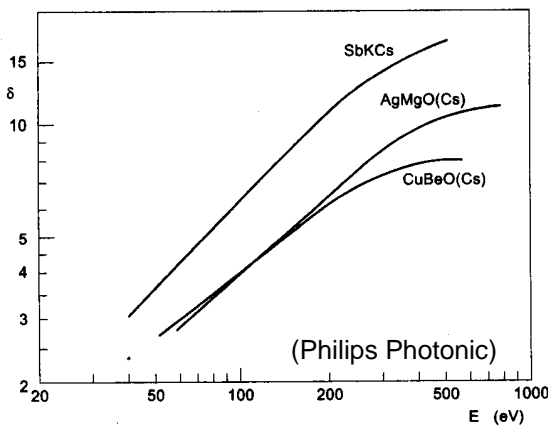

Single photons.
Pulse height spectrum of a PMT with Cu-Be dynodes.

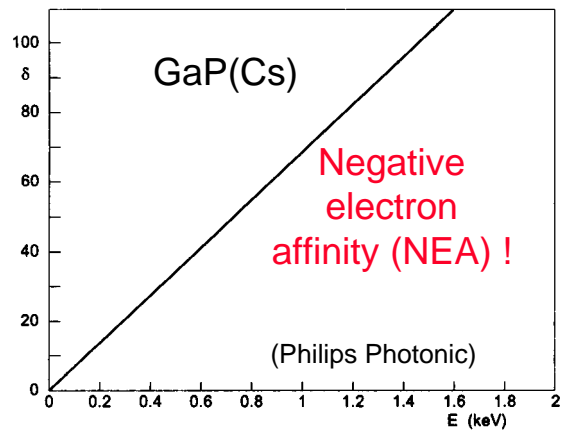
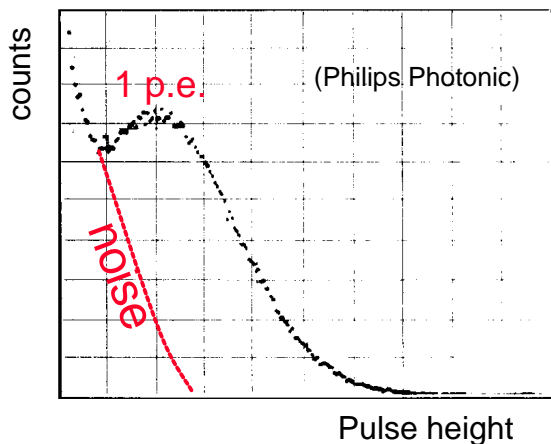

Pulse height spectrum of a PMT with NEA dynodes.

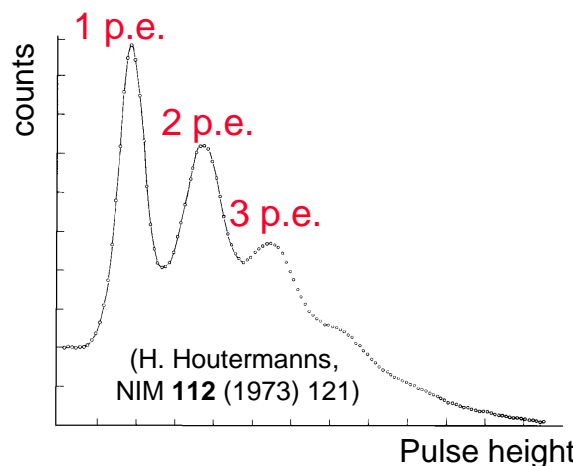

Dynode configurations

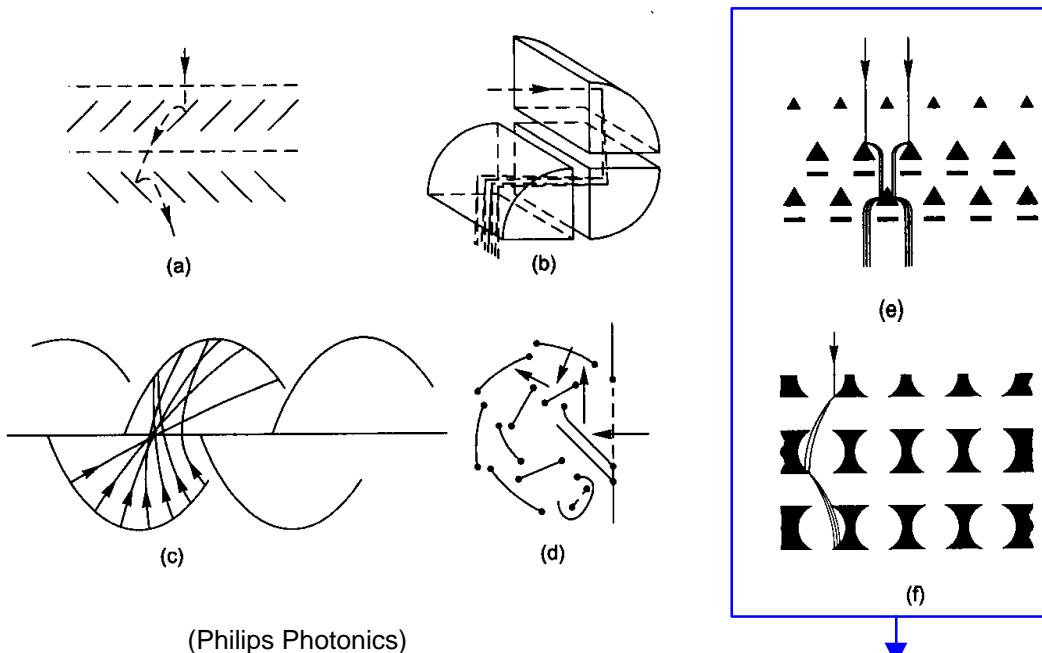

(Philips Photonics)

Dynode configurations: (a) venetian blind, (b) box, (c) linear focusing, (d) circular cage, (e) mesh and (f) foil

position sensitive PMT's

Multi Anode PM

example: Hamamatsu R5900 series.

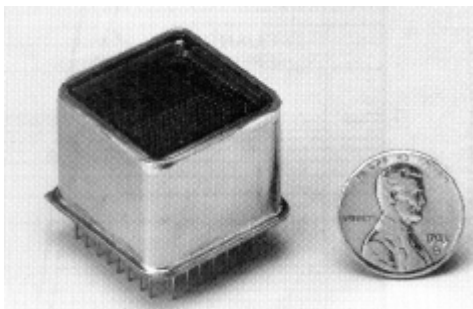

Up to 8x8 channels.

Size: 28x28 mm².

Active area 18x18 mm² (41%).

Bialkali PC: Q.E. = 20% at $\lambda_{\max} = 400$ nm. Gain $\approx 10^6$.

Gain uniformity and cross-talk used to be problematic, but recently much improved.

◆ Hybrid photo diodes (HPD)

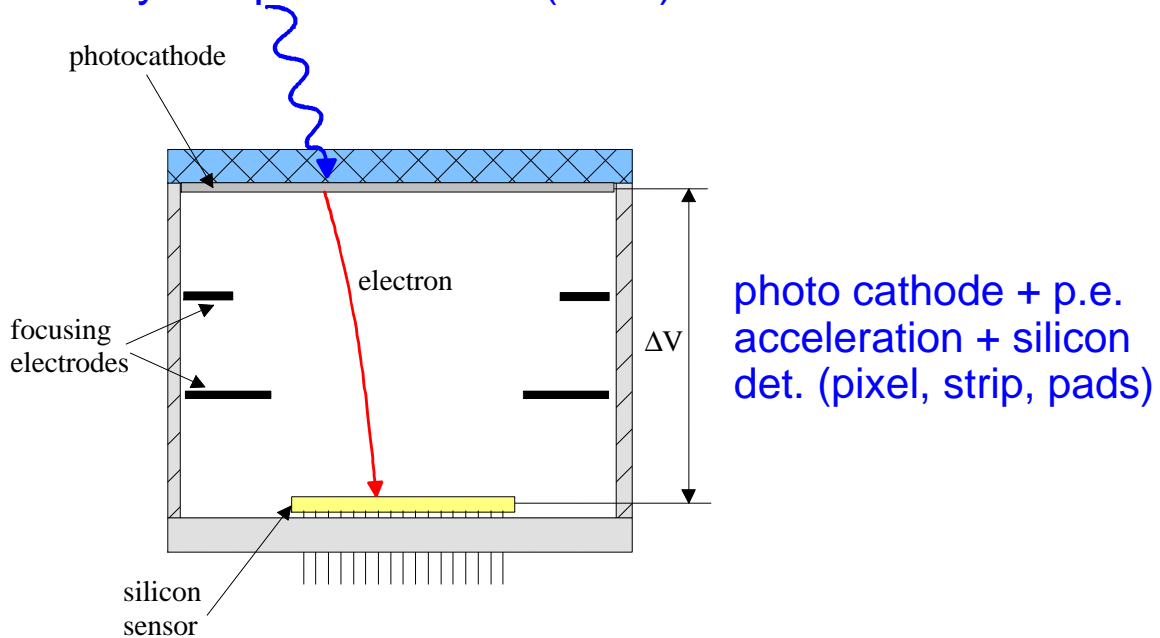

Photo cathode like in PMT, ΔV 10-20 kV

$$G = \frac{e\Delta V}{W_{Si}} = \frac{20 \text{ keV}}{3.6 \text{ eV}} \approx 5 \cdot 10^3 \quad (\text{for } \Delta V = 20 \text{ kV})$$

Single photon detection
with high resolution

Poisson statistics
with $\bar{n} = 5000$!

Background from
electron backscattering
from silicon surface

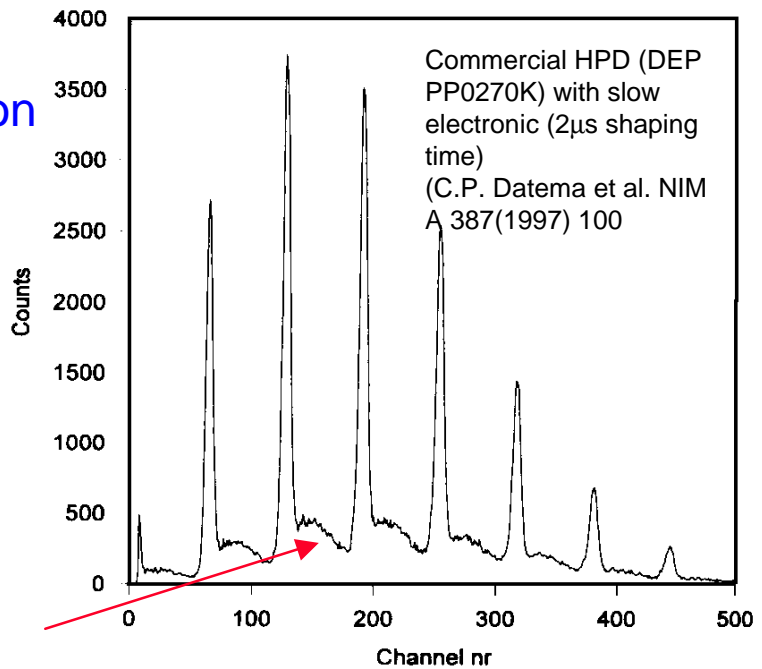



Cherenkov ring imaging with HPD's

(CERN)

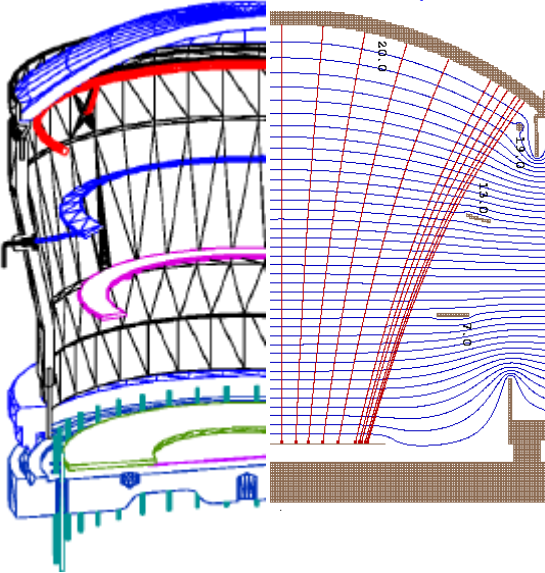

Pad HPD, Ø127 mm,
fountain focused

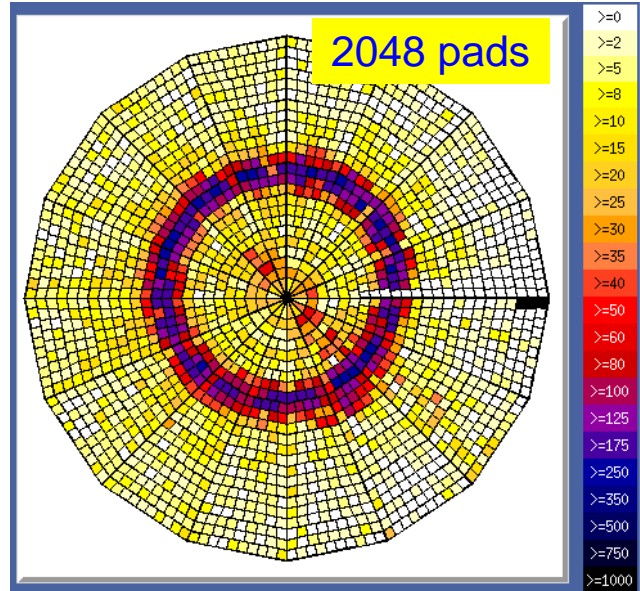

test beam data, 1 HPD

(LHCb - DEP)

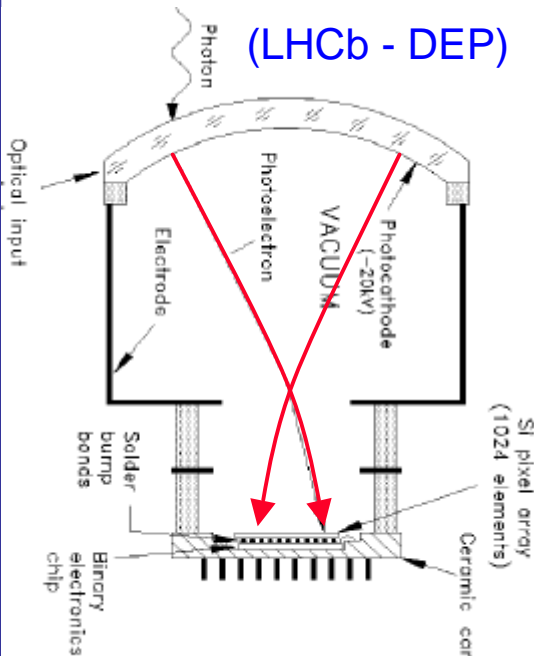

Pixel-HPD, 80mm Ø
cross-focused

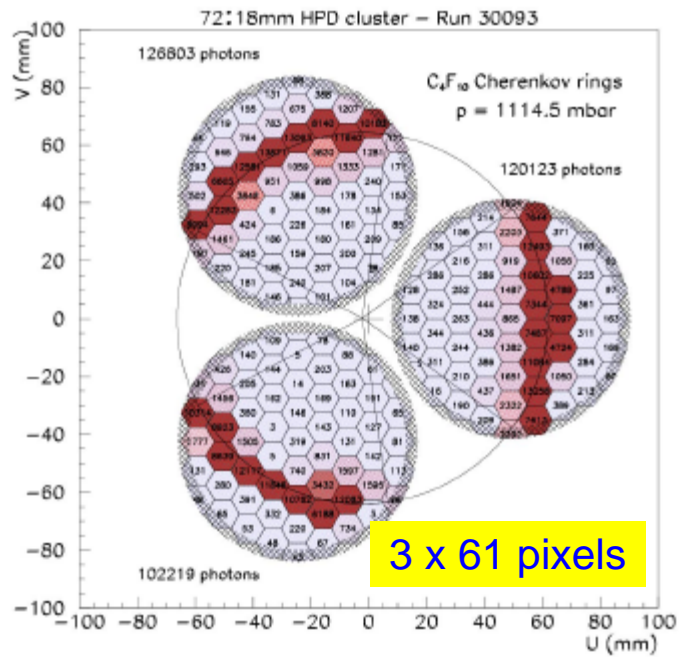

test beam data, 3 HPDs

◆ Photo diodes

P(I)N type



(sketches from J.P. Pansart, NIM A 387 (1997), 186)

High Q.E. ($\approx 80\%$ at $\lambda \approx 700\text{nm}$), gain $G = 1$.

◆ Avalanche Photo diodes (APD)

(J.P. Pansart, NIM A 387 (1997), 186)

High reverse bias voltage $\approx 100\text{-}200\text{V}$. High internal field \rightarrow avalanche multiplication.
 $G \approx 100(0)$

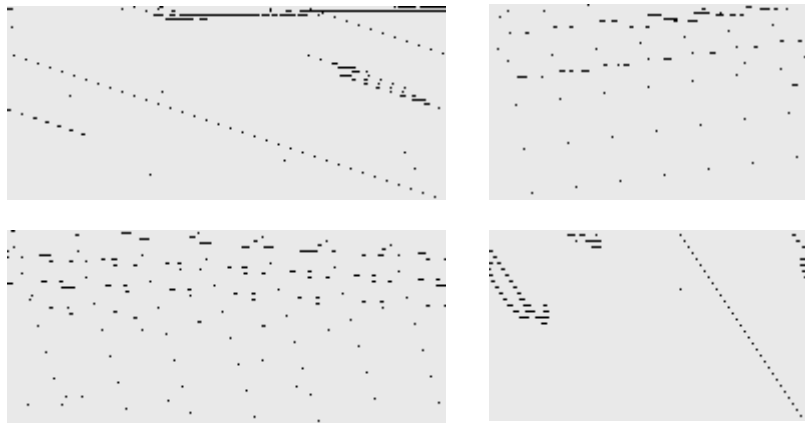

◆ Photo triodes = single stage PMT (no Silicon !)

$G \approx 10$.
work in axial B-fields of 1T
OPAL, DELPHI: readout of lead glass in endcap calorimeter
 G at 1T $\approx 7\text{-}10$

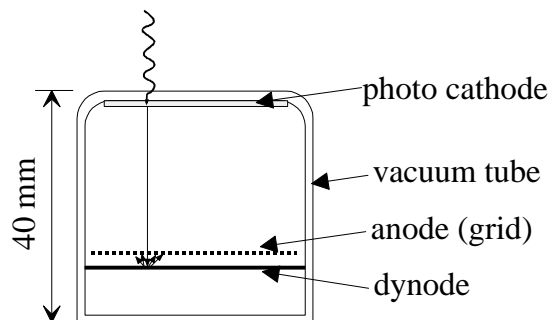

IEEE NS-30 No. 1 (1983) 479

◆ Visible Light Photo Counter VLPC

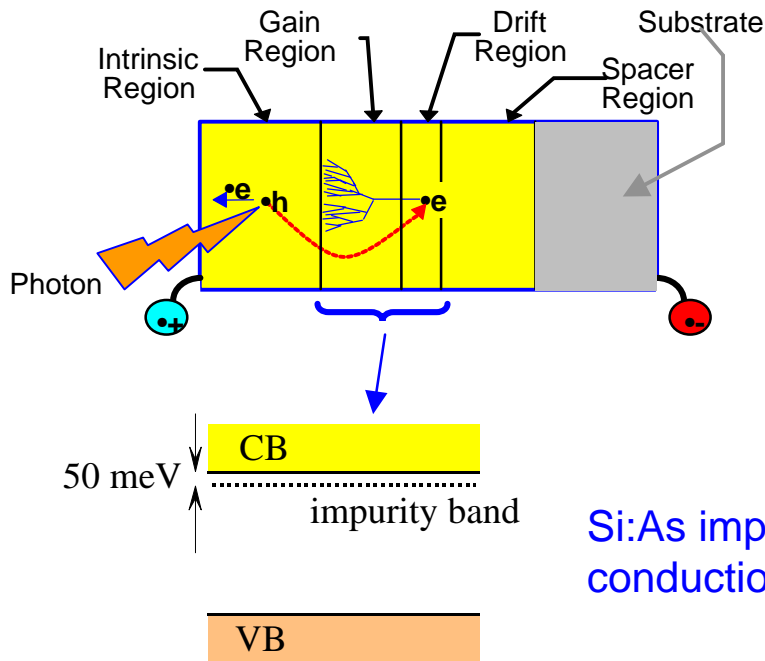

Hole drifts towards highly doped drift region and ionizes a donor atom → free electron. Multiplication by ionization of further neutral donor atoms.

Si:As impurity band conduction avalanche diode

- Operation at low bias voltage (7V)
- High IR sensitivity → Device requires cooling to LHe temperature.
- Q.E. ≈ 70% around 500 nm.
- Gain up to 50.000 !

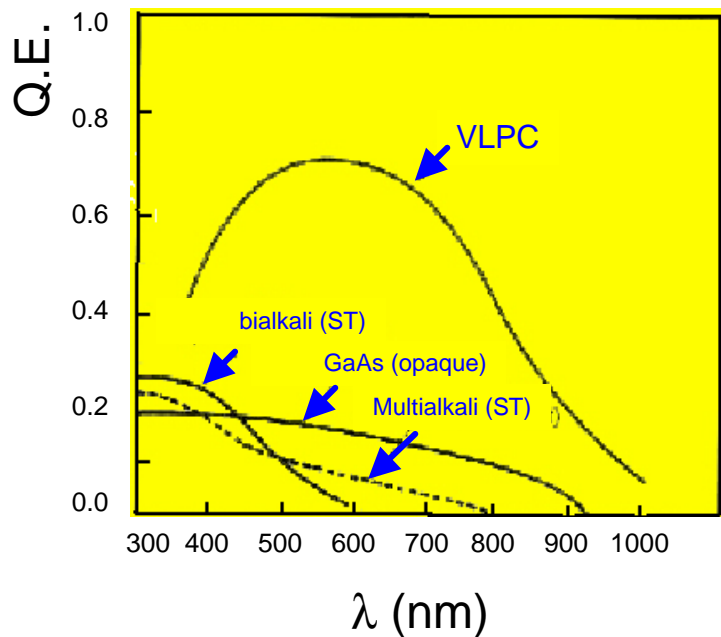

High gain → real photon counting as in HPD

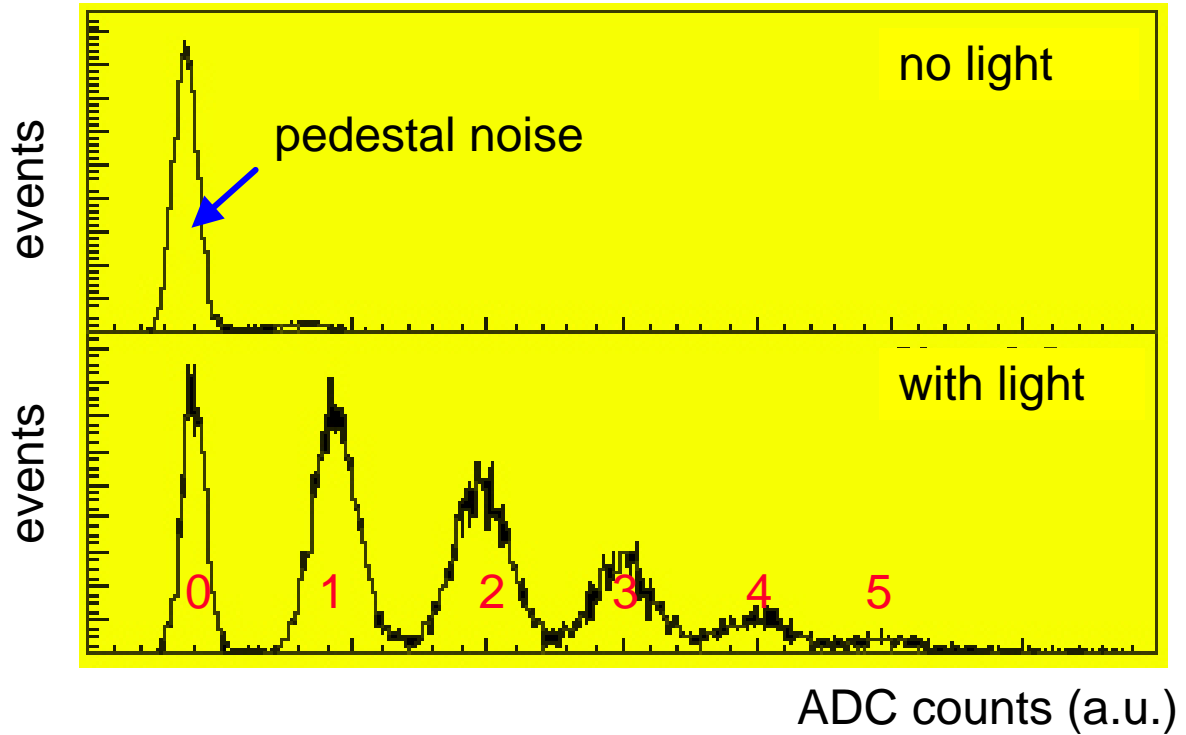

Fermilab: D0 (D zero) fiber tracker (72.000 channels)

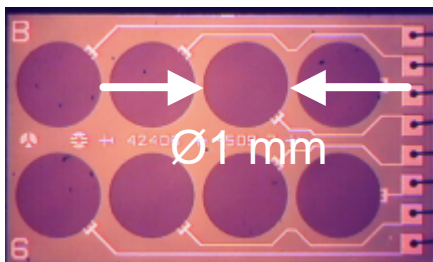

8 pixels per chip
(vapour phase epitaxial growth)