

Proposal for the introduction of Grid technology for the MAGIC telescope

H. Kornmayer^a

^a*Institut für wissenschaftliches Rechnen, Forschungszentrum Karlsruhe, Postfach 3640, 76021 Karlsruhe*

Abstract

The observation of γ -rays with ground based air cerenkov telescopes is one of the most exciting areas in modern astro particle physics. End of the year 2003 the MAGIC telescope started operation. The low energy threshold for γ -rays together with different background sources leads to a considerable amount of data. The analysis will be done in different institutes spread over Europe. Therefore the MAGIC telescope offers the opportunity to use Grid technology to set up a distributed computational and data intensive analysis system with nowadays available technology. This paper presents a first proposal of such a distributed Grid. This Grid might be the starting point for a wider distributed astro particle Grid in Europe.

1 Introduction

The MAGIC telescope [1] was built to detect cosmic γ -rays at low energies around 20 GeV. The lower threshold opens a wide physics potential covering active galactic nuclei (AGN), pulsars, supernova remnants, unidentified EGRET sources, γ -ray bursts and cosmology. The telescope consists mainly of a big $\approx 230 \text{ m}^2$ mirror and a camera of 577 photomultiplier tubes (PMT). This camera is read out with a fast 300 MHz FADC system [2]. The MAGIC telescope is located at the Instituto Astrophisico de Canarias on the island LaPalma, Spain. The telescope was assembled last year and started first operation end of 2003. Detector studies and first observations are ongoing currently. This year the first detections of γ -ray sources are expected.

The collaborators of the MAGIC telescope are spread over Europe with the main contributors located in Germany (Max-Planck-Institute for Physics, Mu-

Email address: harald.kornmayer@iwr.fzk.de (H. Kornmayer).

nich and University of Würzburg), Spain (IFAE, Barcelona) and Italy (INFN, Padua). Most of these main partners have access to a national Grid computing center. These centers may be used to support the MAGIC partners in the operation of a distributed analysis system and in the development of Grid enabled software. The introduction of Grid technology into the MAGIC collaboration would offer the possibility to study more sophisticated analysis methods like e.g. neural network methods. A second MAGIC telescope will be build in 2005 and a system with Grid middleware would provide a scalable environment of further upgrades.

2 The MAGIC Telescope

In this chapter the basic principles of the MAGIC telescope are described and the main problems concerning computing are figured out. The data acquisition system (DAQ) is designed for a permanent trigger rate of 1 kHz. Each pixel of the camera is split in two channels with different amplifications to increase the dynamic range of the photomultiplier tubes. A multi level trigger system is used to select the 8-bit FADC values within a time range of 30 nsec. All these values lead to a raw data stream of 70 GB/hour. The telescope is in operation during moonless nights. The average amount of raw FADC data recorded per night is about 500 – 600 GB/night for one telescope. Concurrently the position of the camera is measured by a CCD system located in the center of the telescope dish. Additional data from the telescope control system or information from a weather station are also recorded. The current atmospheric conditions are observed with a lidar system. All these information have to be taken into account in the data analysis.

The recorded data are mainly background events due to hadrons and myons. The analysis must reduce the number of these background events to get an enrichment of γ -rays in the source region. This enrichment is done by analyzing the image of the cosmic ray showers in the camera plane. Images from different particles recorded with the photomultiplier tube (PMT) in the camera plane are shown in figure 1. The differences of the picture allows an enrichment of γ -rays by applying the methods of Hillas [3]. This method is very effective at higher energies.

The optimization of the γ -rays enrichment needs CPU intensive Monte Carlo studies. These Monte Carlo calculations are done with the air shower simulation program CORSIKA [4][5]. The mean time to compute one air shower in the interesting energy range is about 6.5 sec on a 2 GHz Pentium computer. The production of Monte Carlo events is currently running on one local cluster using CONDOR batch system. On this cluster with around 70 CPUs the production rate is about $3 \cdot 10^5$ events/day. After the subsequent simulation

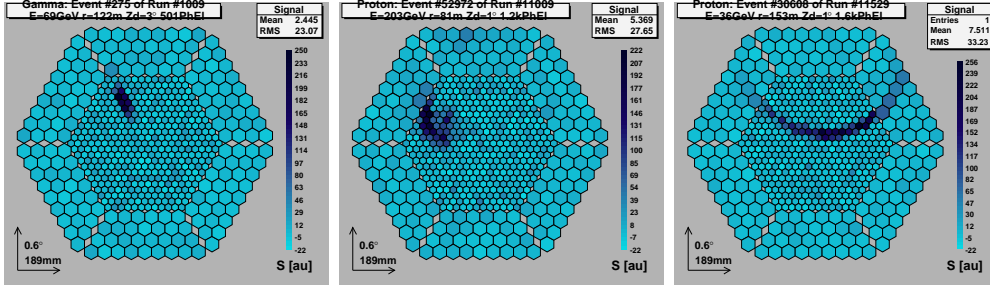

Fig. 1. The view on the camera for events from different cosmic ray particles. The picture was created by integrating the FADC signal over time slices. The left hand pictures shows a event from a γ -ray, the central picture presents a typical hadron picture and on the right hand a so-called myon ring is shown. All these picture are based on CPU intensive Monte Carlo simulations.

of the detector only 7% of the γ and 0.1% of the protons produce a trigger and can be used for further studies. But due to physical reasons this loss is unavoidable. The maximum production rate of triggered Monte Carlo events inside the MAGIC collaboration is ≈ 150 background events and ≈ 10000 gamma-ray events. But this standard procedure does not take into account the the volatility of the atmospheric conditions and the starlight of the night sky background. In principle for each observation one must produce Monte Carlo events taking into account the measured atmospheric conditions and the night sky background light of the observed sky region. To get the same amount of triggered Monte Carlo events and measured real events for one night of observation (mean trigger rate 100 Hz and 8 h observation time) the whole Monte Carlo run would take between 288 days (only γ -rays) and 19200 days (only background). The production of the Monte Carlo events for an air cerenkov telescope under realistic conditions is a great challenge because of the limited resources available. Therefore a good organisation of these computing resources and a systematic production strategy is required.

Also the analysis of the real data of the MAGIC telescope needs the introduction of new technologies. Different observation modes needs different analysis approaches. E.g. the analysis of on-source observations of a specific object is different from the methods used for an all sky survey scan to look for new γ -sources. To study a dedicated source in detail, one needs an easy access to data recorded during specific observation nights (data mining). For the all sky survey a fast access to all available data is necessary to get a result within a reasonable time. Therefore a good organisation of the data storage in combination with the usage of CPU is required.

3 Requirements

A distributed analysis system must fulfill a number of requirements to be really useful. The most important ones are summarized below:

- Security
The access to the Grid resources must be restricted to the partners of the MAGIC collaboration.
- Data access
The access to data of different quality (i.e. raw, preprocessed, analyzed, final results, ..) must be easy and served by the system.
- Data transfer
The transfer of data must be reduced as much as possible. The distribution of data must be controlled by the system.
- Accessibility
The access to the system must be easy and user friendly. There must be a single entry point for the user.
- Availability
The system must run in a 24x7 environment.
- Interactivity
The user must be able to interact with the system on short time scale.
- Scalability
The system must be able to include more resources from inside the MAGIC collaboration. The connection of other external computing and storage resources must be possible. This is necessary to get a small run time for dedicated Monte Carlo or analysis jobs.
- Software distribution
The software for the MAGIC standard analysis must be distributed automatically to all resources in the system.
- Quality
A quality assurance procedure must be installed to reach a high reliability of the distributed standard analysis. The development of new software must be supported by the quality assurance procedure.

4 Architecture

The basic architecture of a distributed MAGIC analysis system is described in this chapter. The proposed design can be taken as a first blue print for further discussions. The presented design is based on the following assumptions:

- The German Grid center at Forschungszentrum Karlsruhe, the Italian Grid center at CNAF in Bologna and the Spanish Grid center at PIC, Barcelona

will join this effort and will built the backbone of the system.

- The MAGIC partners will open their current resources to the system.
- The raw data will be transferred from LaPalma to PIC, Barcelona.
- The system will be built on top of the Globus toolkit [6]

The backbone architecture of the system is presented in figure 2.

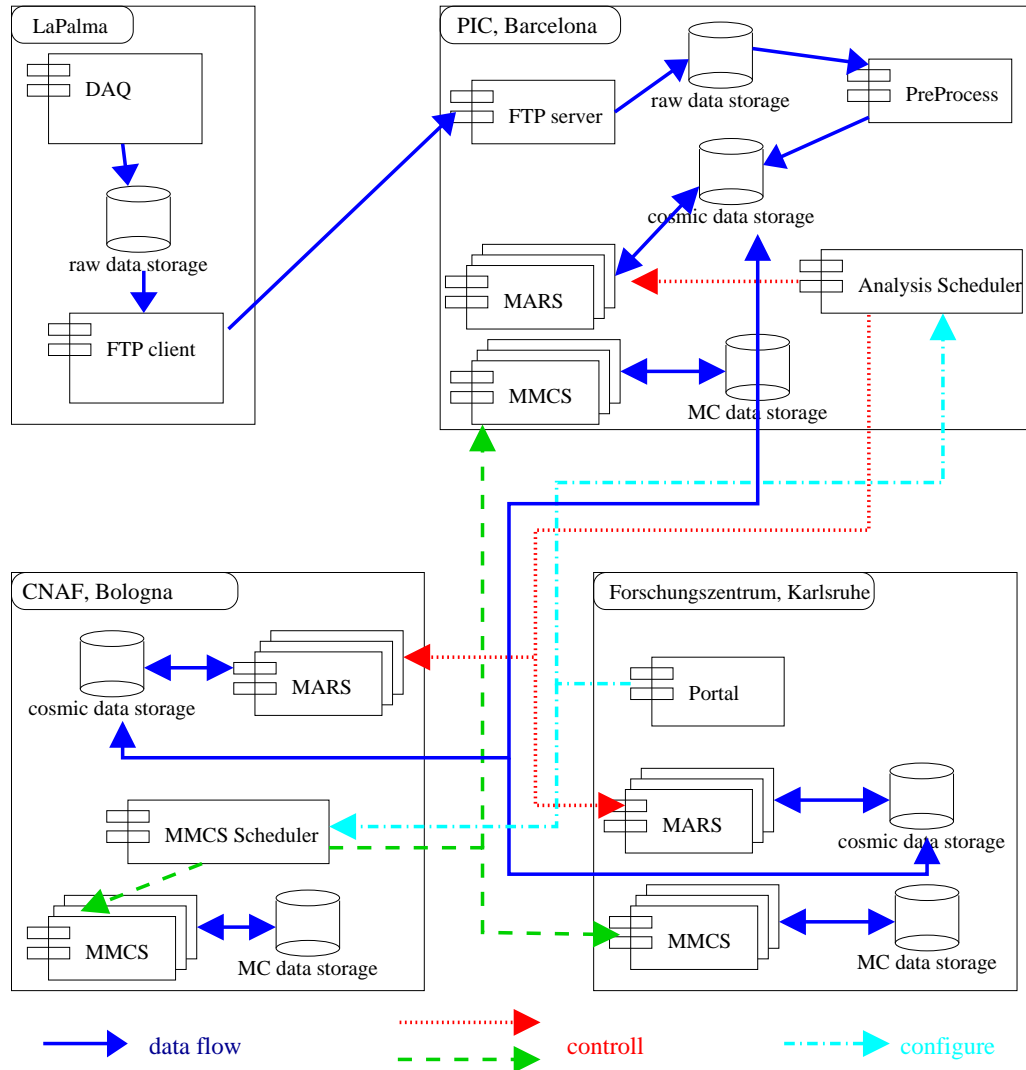

Fig. 2. The design of the backbone for the distributed computing system shows the main components. The data from cosmic ray showers will be distributed. The corresponding dataflow is drawn as the solid lines. The main two computing tasks - analysis (MARS) and monte carlo production (MMCS) - are performed at all sites. They are controlled by two schedulers located at different sites. The access to this scheduler is available via a portal from every webserver.

The backbone of the system is located at the three Grid centers and the DAQ system on LaPalma. The necessary services are distributed to different locations. Following local components are needed:

- LaPalma
 - DAQ

The data acquisition (DAQ) system controls the MAGIC telescope and combines the measured data from all subsystems of the telescope to one raw data file.
 - FTP client

The FTP client will transfer the raw data to the PIC in Barcelona. The transmission must be secure. Therefore the system will use gridFTP, where a security layer is already included.
- PIC, Barcelona
 - FTP server

This component takes the data from LaPalma and puts them into the *raw data storage system*. The transmission must be secure. Therefore the system will use gridFTP, where a security layer is already included.
 - preprocessing

This process starts if the transmission of data from the experiment has finished. It reduces the amount of data by applying different methods of image cleaning, etc. The output will be stored in a distributed database called *cosmics data storage system*. The access to this distributed database will be based on replica catalogs provided by the Globus toolkit.
 - analysis scheduler

The analysis of the preprocessed data will be distributed over the whole analysis system. The scheduling of jobs and the distribution of the preprocessed data is controlled by this component. The distribution of the jobs will be based on resource broker technology from the globus toolkit.
 - MARS

The “MAGIC Analysis and Reconstruction Software (MARS)” is deployed to all nodes to analyse the preprocessed data. The software already developed in the MAGIC collaboration with OO technology needs to be adapted slightly.
 - MMCS

The “MAGIC Monte Carlo Simulation Software (MMCS)” is deployed on all nodes to run the air shower simulations. The output data are stored in a distributed data storage system called *Monte Carlo storage system*. The current software might be used with small changes.
- CNAF, Bologna
 - Monte Carlo scheduler

This component controls the production of Monte Carlo data in the whole system. The distribution of the jobs will be based on resource broker technology from the globus toolkit.
 - MARS

see above
 - MMCS

see above
- Forschungszentrum, Karlsruhe

- MAGIC Portal

This component is the interface between the user and the system. The user can access the portal with a web browser. A single-sign-on method is used for authentication. The portal is the GUI for the system. The portal sends requests to the *analysis scheduler* and *MonteCarlo scheduler*. Results of the analysis and monte carlo jobs are presented here in an interactive way [7].

- MARS
see above
- MMCS
see above

Local computers from a MAGIC partner site can connect to the closest of the backbone nodes to offer their computing resources. On a partner site the MARS and MMCS components are deployed to contribute to the analysis and Monte Carlo production. During the deployment they will register at the *analysis scheduler* and the *MMCS scheduler*. The schedulers will send the jobs to the local partner sites.

5 Development

The development of the system will be done in different steps.

- (1) prototype for MMCS production

In the first phase the current production of Monte Carlo data will be moved to a Grid technology based system. Only very small changes on the current MMCS software might be necessary. The first version of MMCS scheduler will be developed to get experience with the distributed computing and storage environment. The deployment will be restricted to the backbone nodes. Also the first version of the portal will be implemented to demonstrate the benefit of a worldwide access to the system. The functionality of the security concept can be proven.

- (2) MMCS production and analysis prototype

In phase two the Monte Carlo production will start with the backbone nodes. The first MAGIC partner sites will be connected to the backbone to contribute to these computations. The transfer of raw data from the MAGIC telescope to the PIC in Barcelona will be set up. The preprocessing will be included and the first version of the distributed analysis software will be developed. The analysis (MARS) will run only on the backbone nodes of the system. The portal will be extended to support the GUI for the analysis.

(3) Analysis production and further developments

The analysis will be deployed to all local MAGIC partner sites. Each member of the collaboration can run their specific analysis on the Grid. The overall computing power will support the development of other analysis methods like e.g. neural networks, etc. The development will be done on the same resources in a separate virtual environment to prevent interference with the production system. The connection of other Grid resources like commercial providers or other Grid centers can be tested to demonstrate the scalability of the design.

The realisation of the first two steps can be done in less than one year with the reasonable personnel of two developers at the three backbone Grid centers respectively. That time is also needed by the MAGIC collaboration to reach the full potential of telescope. Starting an effort now to set the proposed system for the MAGIC telescope will provide a Grid based system in a perfect coincidence with the time when the first MAGIC telescope will reach the full physics potential. The system will be operating for one year when the second MAGIC telescope will start observation in summer 2005.

6 Future prospect

The energy range of ground based astro particle physics ranges from 10^{13} eV up to 10^{20} eV. The simulation of the air showers in the atmosphere especially at high energies requires a lot of computing time. These computations can be split into subcomputations on a Grid environment to reduce the mean computing time for one air shower. This can be done e.g. with the grid-enabled implementation of MPI (Messaging passing interface).

The understanding of cosmic ray sources like AGN or supernovae is based on measurements from various energy ranges measured with different experiments. A Grid environment might offer data-mining functionalities to combine the results from different experiments.

The astro particle physics community can benefit from the usage of Grid technologies. All the efforts must be coordinated to set up a Grid for astro particle physics. The proposed system for MAGIC might be a starting point for that ASTROPA Grid.

7 Summary

The analysis of data from the MAGIC telescope needs computing and storage resources. The collaborators are mainly spread over Europe. A design of a distributed system for analysis and Monte Carlo production for the MAGIC telescope is worked out. The project can be realized with three Grid centers in Italy, Spain and Germany together with the main partner of the MAGIC telescope on a reasonable timescale. The system can be ready when the MAGIC telescope will reach the full observation potential. This is the challenge to introduce Grid technology into the field of astro particle physics.

The proposed Grid will show the benefit of Grid technology in the field of astro particle physics. Many other experiments from that field are in the pipeline in the next years to observe cosmic rays in the energy range between 10^{13} eV up to 10^{20} eV . The proposed system might be the starting point for a wider distributed Grid for astro particle experiments.

8 Acknowledgement

The author wants to thank all the colleagues from the MAGIC collaboration. Manuel Martinez (IFAE, Barcelona) and Mose Mariotti (INFN, Padua) for principally supporting the idea of Grid technologies for MAGIC. Special thanks to Abelardo Moralejo and Ciro Bigongari (both INFN, Padua), Robert Wagner and Florian Goebel (MPI, Munich) for their fast response to my stupid questions. This proposal was only possible because Marcel Kunze (Forschungszentrum Karlsruhe) supports this idea with enthusiasm. Holger Marten (Forschungszentrum Karlsruhe) reads the draft of this proposal carefully and made valuable comments. Thanks also to the CrossGrid collaboration and the Grid team at FZK for gathering experiences in Grid technologies over the last two years that will be useful for that kind of dissemination projects.

References

- [1] E. Lorenz, 1995, Frühjahrtagung Deutsche Physikalische Gesellschaft, March 9-10
- [2] J. Cortina et al., 2002, T10, Proceedings of the int. Symposium “The Universe in Gamma-rays”, University of Tokyo, Kashiwa, September 22-28
- [3] A.M. Hillas, 1985, Proc. 19th ICRC (La Jolla), vol. 3, p. 445
- [4] J. Knapp, D. Heck, 1998, EAS Simulation with CORSIKA, A User’s Manual

- [5] J. N. Capdevielle et al., 1992, The Karlsruhe Extensive Air Shower Simulation Code CORSIKA, KfK report 4998
- [6] The Globus toolkit, <http://www.globus.org>
- [7] M. Bubak et al., 2003, Architecture of the Grid for Interactive Applications, in: Sloot, P. M. A., et al. (Eds.), Proceedings of Computational Science - ICCS 2003, International Conference Melbourne, Australia and St. Petersburg, Russia, June 2003, vol. I, no. 2657, Lecture Notes in Computer Science, Springer, pp. 207-213