

Workflow solutions, EDH and e-commerce

Derek Mathieson
Section Leader
IT-AIS-EB

The Need for EDIH

- Over 100 official procedures
- Used by all CERN personnel
- Over 250000 documents per year
- Examples:
 - Purchase orders
 - Training Request
 - Holiday Request

A Worldwide Community

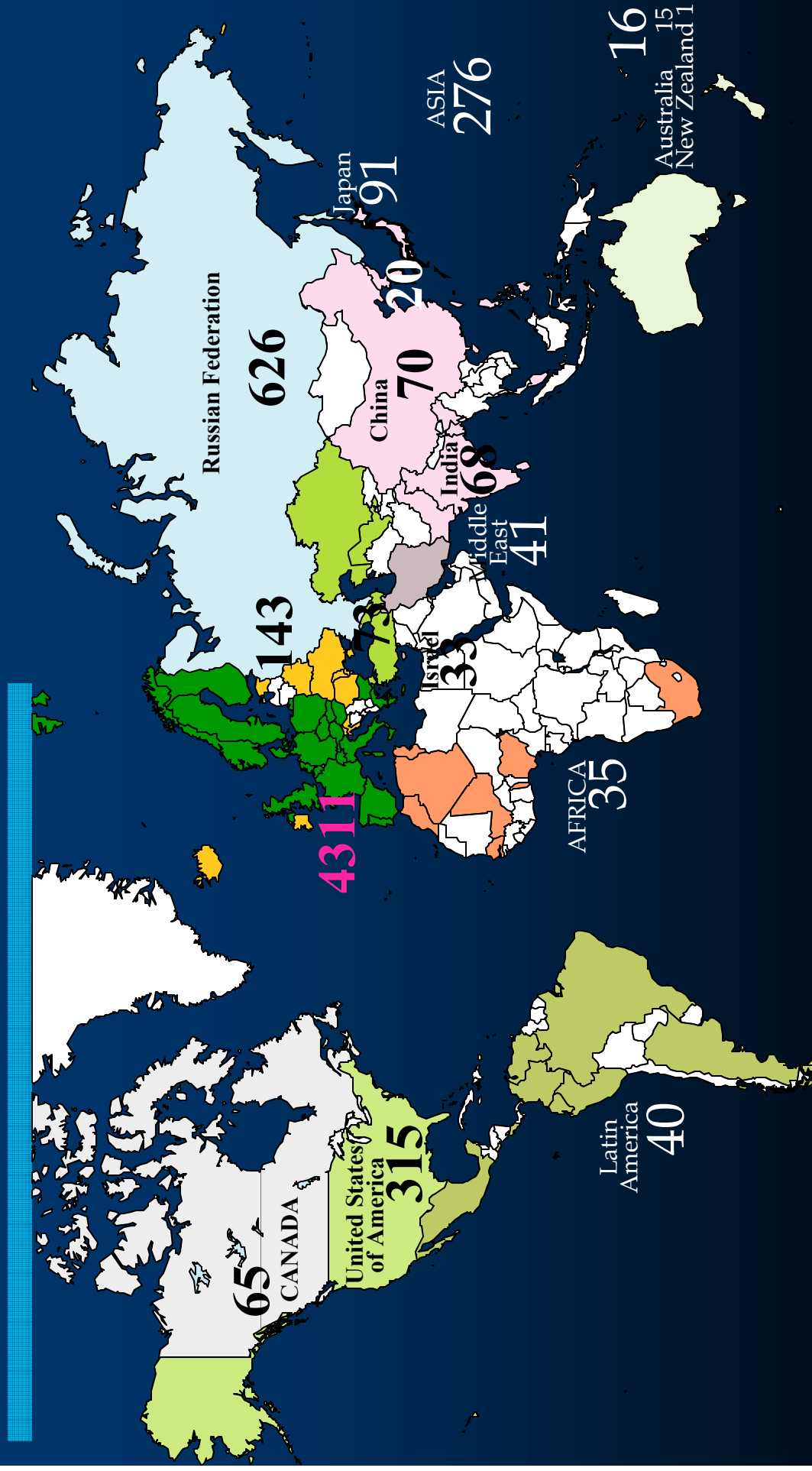

A Truly “Global” Organization

Paper Purchase Order

CERN Demande d'achat interne
Internal Purchase Requisition

Page No. :

Code _____ Programme _____ Free division _____ (in) class _____ or _____ (a) project _____ or _____ D/E _____

Dem. REQ. : N° 185498
Montant estimatif : env. 200 Fr
Code : 16300
Date : 2.4.92 Année budg. : 1992
Job No. :
Demandé par : B. Lorenz Tél. No. : 2093
Contrôlé par : N. Blackburne
Approbation : _____

(code LIB 50)
Fournisseur proposé/préféré :
Suggested/preferred supplier:
LIBRAIRIE CENTRALE ET
UNIVERSITAIRE DE
LAUSANNE
Date de livraison demandée : Dès que possible
Delivery date required:
A quel endroit du CERN voulez-vous
que le matériel soit livré? Bât. 4 - 3-048
Where at CERN do you want the material
to be delivered?

PRIÈRE DE JOINDRE LA DOCUMENTATION NÉCESSAIRE SE RAPPORTANT A CETTE DEMANDE D'ACHAT
NE PRENDRE AUCUN ENGAGEMENT VIS-A-VIS DU FOURNISSEUR SANS L'ACCORD PRÉALABLE DU
CHEF DU SERVICE DES ACHATS (REGLES FINANCIERES INTERIEURES DU CERN, ANNEXE II, 7)

Please attach necessary documentation relating to the requisition
Do not make any commitment with the supplier without prior approval of the Purchasing Officer
(CERN Internal Financial Regulations, Annex II, 7)

Pos. Item	Description: (max. 30 caract)	Quantité Quantity	Prix unitaire si possible Unit Price if known	Réserve au Service des Achats For Purchasing Office only
1	PETIT ROBERT 1 (dernière édition)	1 ✓		
2	ROBERT & COLLINS (dernière édition) (Anglais-Français)	1 ✓		
3	PONS WEIS MATTUTAT (Français-Allemand)	1 ✓		

Notes: 1 Robert 1, 2 Robert & Collins, 3 Pons Weis Mattutat

Almost any Procedure

Demande Achat Interne 774838 - Netscape
 File Edit View Go Communicator Help
 Bookmarks Netsite: https://edh.cern.ch/Document/DAI/774838

Demande Achat Interne (DAI)
774838

Fields with asterisks (*) are obligatory and must be filled in.

General Description *: ?

Technical Contact *: ?

Supplier: ?

Country of Distribution *: ?

Currency *: ?

Total Value **\$8,988.00 (SFr. 15,009.96) ?**

Item Quantity	Description	Unit Price	Price
1	Multimeter Multimeter Keithley Model 2002/MEM2/E Budget Codes: 81613 , Country of origin: US , Delivery: 865-R-D24 , Activity Codes: 337 , Enter goods in inventory: Yes	\$6,714.00	\$6,714.00
		Duplicate Modify Delete	
2	Scanner Scanner with IEEE-488 Bus Budget Codes: 81613 , Country of origin: US , Delivery: 865-R-D24 , Activity Codes: 337 , Enter goods in inventory: Yes	\$2,274.00	\$2,274.00
		Duplicate Modify Delete Add Re-order	

Click to add a new line item

Additional information

Purchasing officer: ?

Comments to: ?

Almost any Procedure



HR Leaveing

Workflow in Action

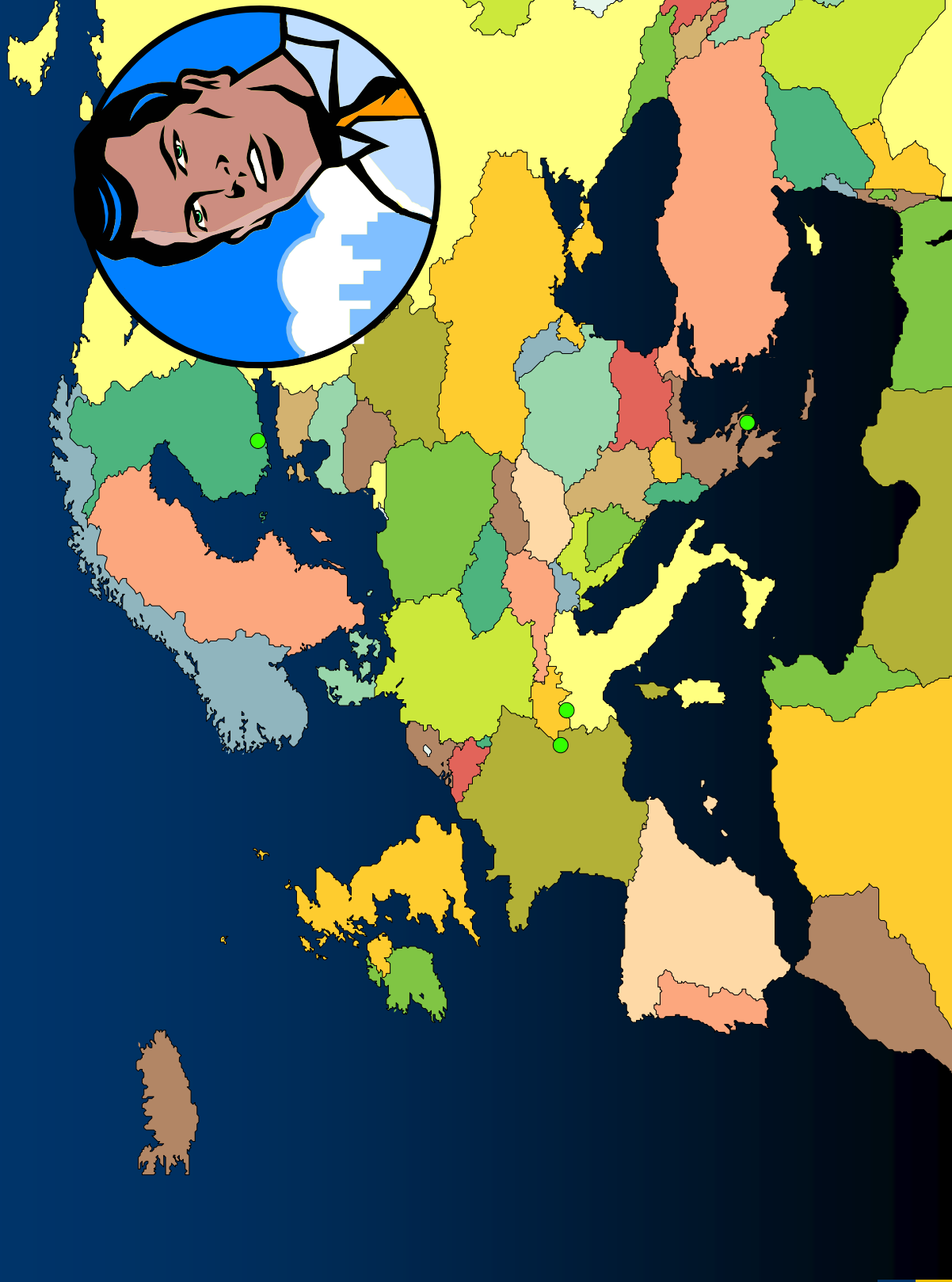

Workflow in Action



Material Request 1654688 - Microsoft Internet Explorer

File Edit View Favorites Tools Help

Material Request 1654688

Contact: cern.stores@cern.ch

Fields with asterisks (*) are obligatory and must be filled in.

General Description: SBC Parts
 Requestor*: Derek MATHIESON (IT-AIS-EB)
 Delivery Location*: 513-1-005
 Requested Delivery Date:
 Delivery Comments:
 Budget Code*: 47117

Total: SFr. 311.80

Clone Pt.View Catalog Delay? Lines Save Send Help

[Find catalog items by SCEM or description](#)

Pos	Unit	Subtotal
1	Quantity: 1 SA SCEM: 08.51.72.305.8 LIGHT EMITT D. HLMP-3301 RED (1 SA = 10 PC) Item in stock, you will be served within 1 working day. Pls contact Laurent GILLAIN for more info.	1.80 X>Delete
2	Quantity: 2 PC SCEM: 08.56.38.200.2 INT.CIRC.LCA XC 3042-70PC 84 Item in stock, you will be served within 1 working day. Pls contact Laurent GILLAIN for more info.	44.00 X>Delete
3	Quantity: 4 PC SCEM: 08.59.00.100.4 INT.CIRC.INTERFACE VME 3000 Item in stock, you will be served within 1 working day. Pls contact Laurent GILLAIN for more info.	266.00 X>Delete
Total: SFr. 311.80		

Click to add a new order line [Add](#)

Done Local Intranet

Workflow in Action

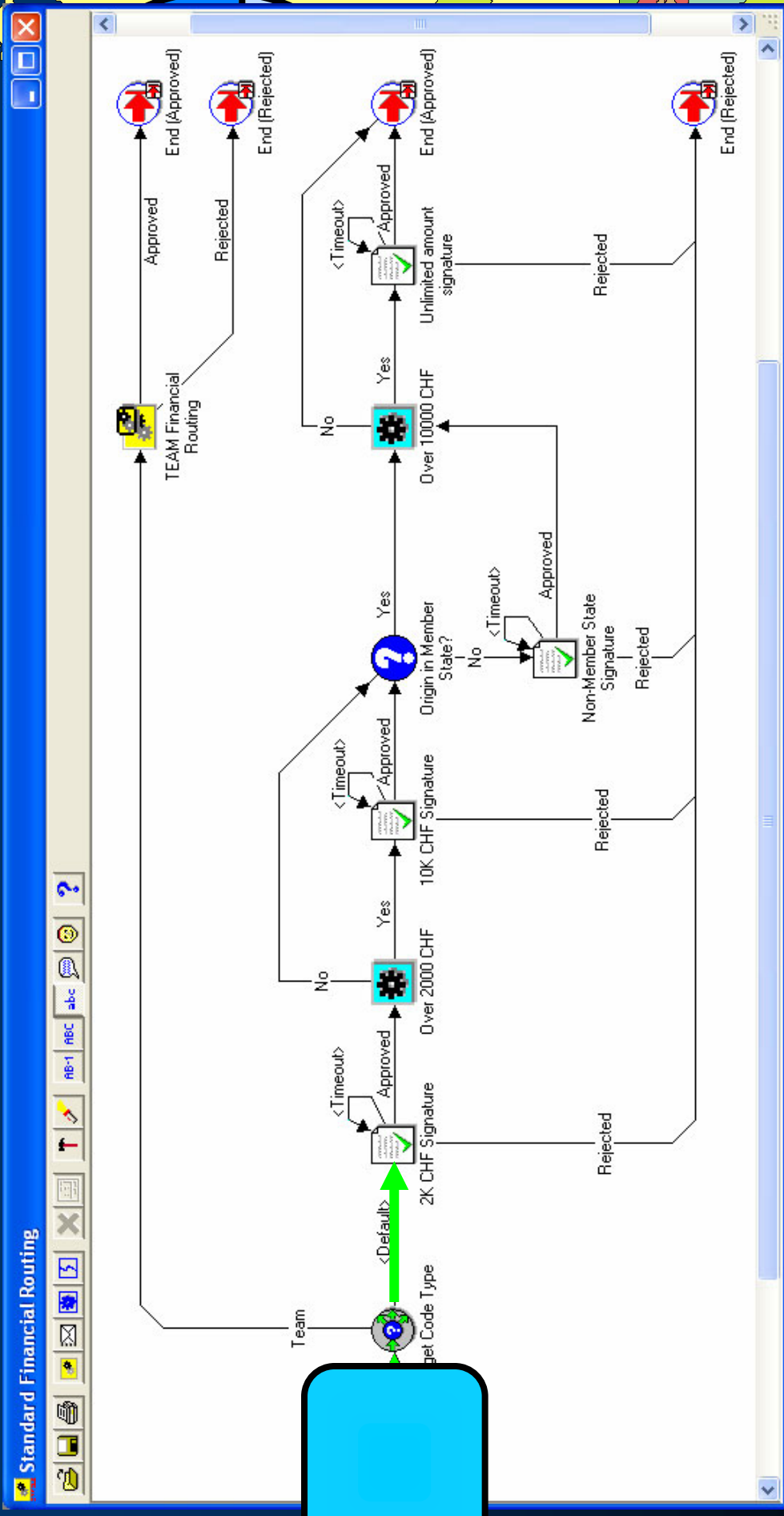

Workflow in Action

Material Request 1654688 - Microsoft Internet Explorer

File Edit View Favorites Tools Help

CET Transactions By Cost Centre - Microsoft Internet Explorer

File Edit View Favorites Tools Help

Transactions By Cost Centre
Nature Type Materiel & Tiers and Time Period This Year + Carry Over and Budget Code 47117

Search Criteria: Open All Restore

Organic Unit: Nature Type:
 Budget Code: 47117 ? Nature Code:
 Project: ? Destination (Activity):
 PPA Unit: ? Recurrency: All ?
 Time Period: This Year + Carry Over ? Pipeline: All ?
 Pipeline Transactions Only:

Budget Order Code	Technical Contact	Parent Agreement	Last Modified Date	Creation Date	Order Description	Provision Balance This Year (CHF)	Paid Budget Code (CHF)	Annual Commitment (CHF)	Annual Open Commitment (CHF)	Pipeline (CHF)	Order Status
1	47117 PAYCL AX01635761		16.06.2004	16.06.2004	TITOV (45249) Official travel expenses	1,196.00	1,196.00	1,196.00	1,196.00		
2	47117 PHONE 0401		16.01.2004	16.01.2004	Telephone	0.64	0.64	0.64	0.64		
3	47117 PHONE 0402		20.02.2004	20.02.2004	Telephone	0.21	0.21	0.21	0.21		
	47117 PHONE 0403		25.03.2004	25.03.2004	Telephone	0.87	0.87	0.87	0.87		
	47117 PHONE 0406		25.06.2004	25.06.2004	Telephone	0.52	0.52	0.52	0.52		
Subtotal for 47117:						66,736.90	66,736.90	66,736.90	108,853.00		
Grand total:						66,736.90	66,736.90	66,736.90	108,853.00		

Rows returned: 59

Budget Code Breakdown:

Budget Code	Paid (Charged to Budget Code CHF)	Annual Commitment (CHF)	Annual Open Commitment (CHF)	Payment Budget (CHF)	Pipeline (CHF)	Commitments incl. Pipeline	Balance (Including Pipeline)	Balance (Excluding Pipeline)
47117	66,736.90	66,736.90	215,000.00	0.00	108,853.00	175,589.90	39,410.10	148,263.10
Grand Total:	66,736.90	66,736.90	215,000.00	0.00	108,853.00	175,589.90	39,410.10	148,263.10

Runtime: 2

Done Local intranet

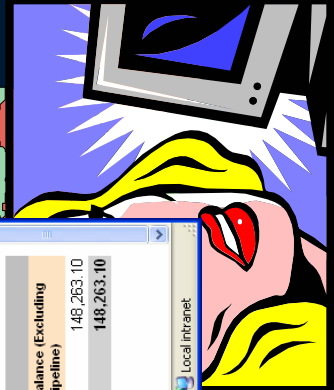

Workflow in Action

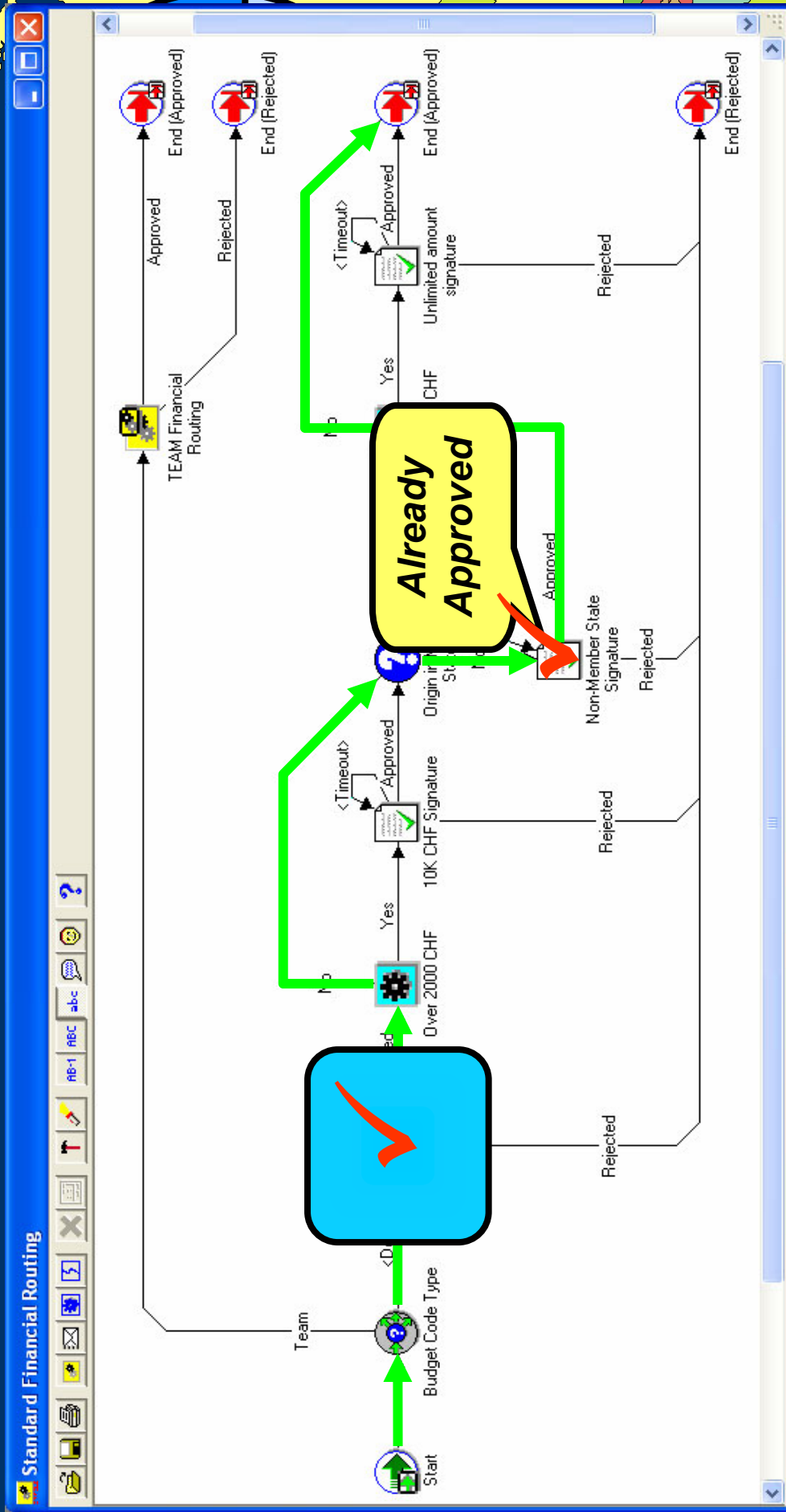

Workflow in Action

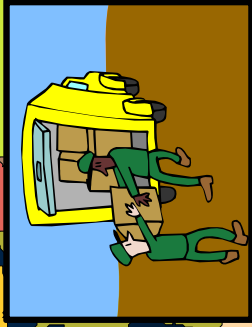

EDH Components

EDH Document Example

Demande Achat Interne - Microsoft Internet Explorer

Address: <https://edh.cern.ch/Document/DAI?clone=%%EDH2>

Demande Achat Interne (DAI)

General Description *: ?
[Technical Contact *:](#) ?
[Supplier:](#) ?
[Country of Distribution:](#) ?
Currency *: ?
Total Value ?
Delivery Costs included *: ?
[Divisional Request \(CFU\) No.:](#) ?

Item Quantity	Description	Unit Price	Price
1 500	Nanocristallin Imphy pour blindage Ruban en matière nanocristallin Imphy avec adhésifs en polyester. 500 meters selon échantillon déjà livré. Selon offre: 13034 Budget Codes: 96628 , Country of origin: FR , Delivery: 866-1-A01 , Activity Codes: 516 , Enter goods in inventory: No	E9.50	E4,750.00

Click to add a new line item

Additional information

Purchasing officer: Robert MULLER
Comments to Purchasing officer: This order concerns the offer from

Local Intranet

Oracle Workflow

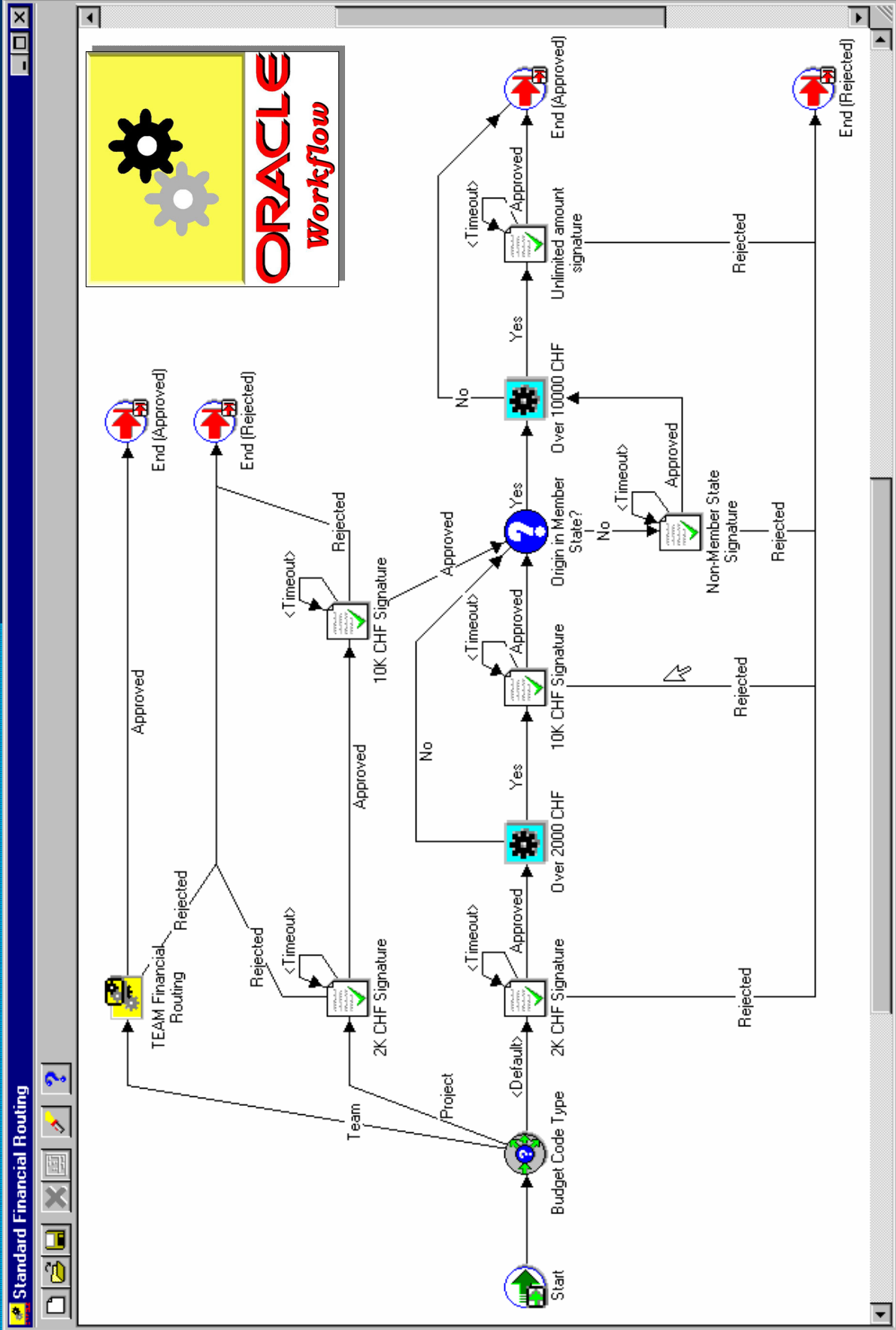

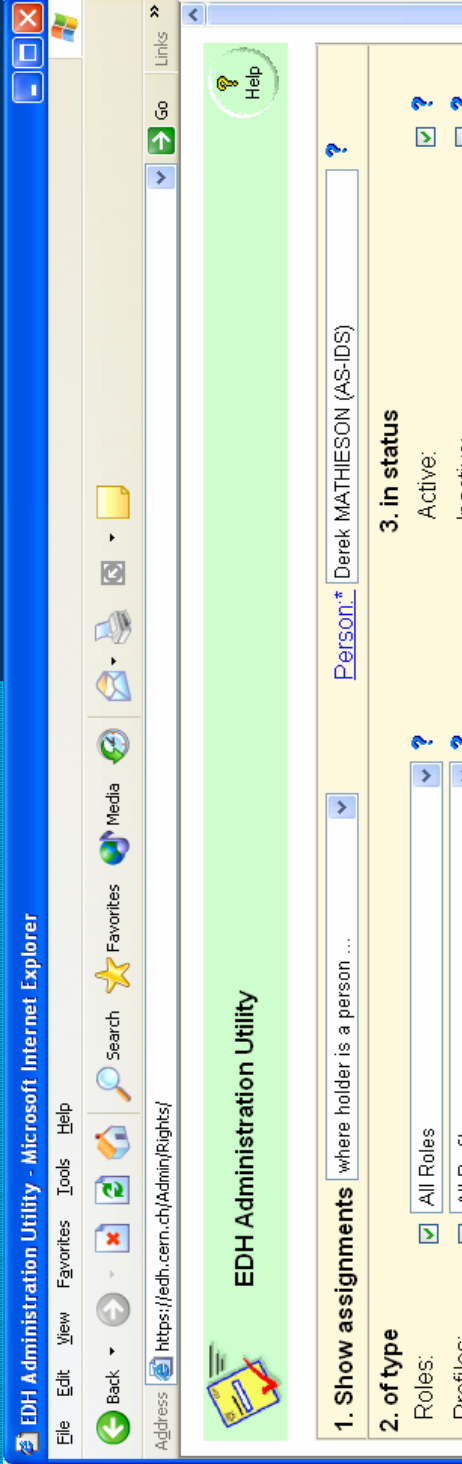

Permission Management by EDH



Roles held by Derek MATHIESON (AS-IDS)

Priority	Holder	Type	Target	Validity date(s)	
4	Derek MATHIESON (AS-IDS)	DGL	AS-IDS	01.01.2003	 

Profiles held by Derek MATHIESON (AS-IDS)

Priority	Holder	Type	Target	Validity date(s)	
2540	Derek MATHIESON (AS-IDS)	OFC(DGL)	16150	01.01.2003	 
2540	Derek MATHIESON (AS-IDS)	OFC(DGL)	16151	01.01.2003	 
1000	Derek MATHIESON (AS-IDS)	SPA	Slava TITOV		 

EDH Architecture

'Classical' 3-tier



'Thin'
Web Client

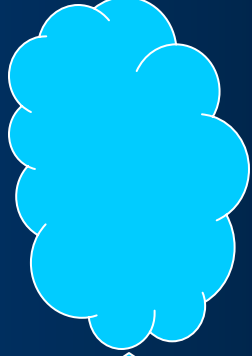

Network
Intra / Internet

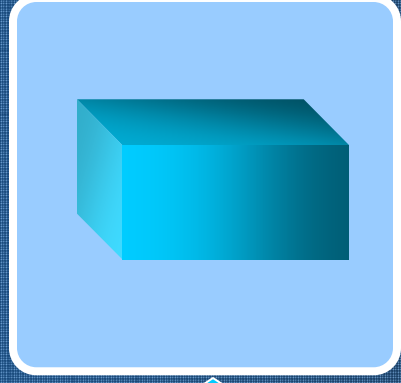

9i Application
Server

App Server 9.0.2
Sun Enterprise 450
4 CPU
2Gb Ram
250Gb RAID Disk

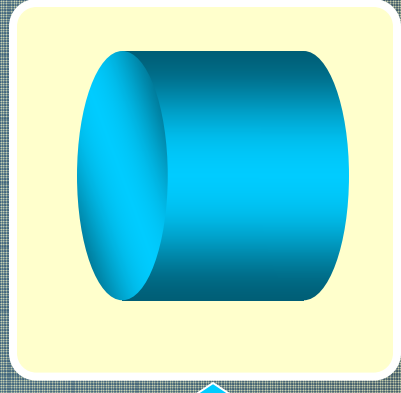

Oracle Database

Oracle 8.1.7.4
Sun Enterprise 420R
4 CPU
4Gb Ram
300Gb RAID Disk

Standards Based

- Architected around industry standards
- Rigorous quality assurance procedures
 - Recognised by Sun and Oracle as a ‘blueprint’ design.



Electronic Document Handling

- Global, multi-currency, multi-lingual
- Links 20,000 suppliers
- Over 7,800 Active Users
- 250,000 signatures per year
- 8 hits per second on the website
- Implements **any** business process
- World Wide Workflow

Meeting the Challenge

- Reduce costs ● At least 35 FTE saved
- Increase efficiency ● Reuse – cloning
- Streamline processes ● 93% < 24hours
- Increase productivity ● Focus on core activities
- Empower workforce ● Delegation of rights
- Maintain control ● Enforcing business rules

EDH Technology Summary

EDH

- 10 years of Workflow Experience
- Proven, Flexible, Component-based Design
- Technology Transfer
 - Technology Transfer of EDH in 2002
 - Financial Problems of Parent Company
 - IP still belongs to CERN