

Design of a z-Vertex Trigger and its Operation Experience in the H1 Experiment at HERA

M.C. Urban

University of Zürich, Winterthurer Strasse 190, 8057 Zürich, Switzerland
Max.Urban@desy.de

Abstract

The CIP2K trigger system has become an integral part of the H1 detector for the HERA II run. Its purpose is the reconstruction of the interaction point. Using this z-vertex position events from positron-proton interactions are separated from residual gas background on the first trigger level.

A total of 8500 channels transmitted by optical links from a multi-wire proportional chamber are analyzed at a speed of 10.4 MHz in parallel, synchronized to the accelerator clock. The trigger latency is 1 μ s. The signals are analyzed on 16 Trigger Cards, each holding two Altera APEX20kE400 FPGAs. The system design and first results from the HERA II run are presented.

I. INTRODUCTION

The electron-proton collider HERA (Hadron Electron Ring Accelerator) at DESY, Hamburg/Germany is designed to measure electron proton scattering at high center-of-mass energies (320 GeV). The HERA ring has a circumference of 6.3km. In two separate pipes, protons are accelerated to a maximum energy of 920 GeV and electrons to an energy of 27.5 GeV. The beams collide every 96ns, corresponding to a bunch crossing rate of 10.4 MHz. Compared to fixed-target experiments, the accessible kinematic range is extended to high-momentum transfer Q^2 and very small Bjorken x .

At HERA three experiments are operated, the collider experiments H1 and ZEUS and the fixed-target experiment HERMES.

The electron proton collider HERA at DESY has been upgraded in the years from 2001 to 2003 to extend the kinematic range to higher Q^2 and to improve the sensitivity for detecting non standard model physics. The modifications lead to a significant increase of the specific luminosity of $1.7 \times 10^{30} \text{ cm}^{-2} \text{ s}^{-1} \text{ mA}^{-2}$ which is three times higher than in the HERA I run. The expected integrated luminosity is 250 pb^{-1} per year.

Higher luminosities were achieved by using super-conducting focusing magnets located inside the collider experiments (H1 and ZEUS) in order to decrease the beam cross section. Protons and Electrons were bent to a smaller interaction focus ($110 \times 30 \mu\text{m}$) compared to ($190 \times 50 \mu\text{m}$) at HERA I. In addition the beam currents were increased. The maximum proton current I_p is 135mA (HERA I: 100mA) and the maximum electron current I_e is $\sim 55\text{mA}$ (HERA I: 50mA)[1].

In order to cope with the higher luminosity and to adapt the new beam guidance, both collider experiments had to be upgraded, too. A description of the H1 detector and the modifications that have been carried out can be found at [1], [2].

II. CONCEPT OF THE Z-VERTEX TRIGGER

Motivation for the new z-Vertex trigger:

The new beam guidance leads to an increased synchrotron radiation level produced within the H1 detector. Most parts of this synchrotron radiation can be lead out of the detector. A small fraction, however, hits a proton beam focussing magnet at $z = -10.8\text{m}$ backwards of the nominal interaction point. To reduce backscattering of the radiation into the H1 collector, collimators are installed. Two collimators are installed within the detector at $z = -80\text{cm}$ (C5A) and at $z = -150\text{cm}$ (C5B), another collimator is installed at $z = -10.8\text{m}$. The high level of synchrotron radiation being absorbed leads to an increased rest-gas pressure in the beam pipe close to the absorber at $z = 10.8\text{m}$. As a consequence, the number of collisions between protons and rest-gas molecules (beam-gas) increases.

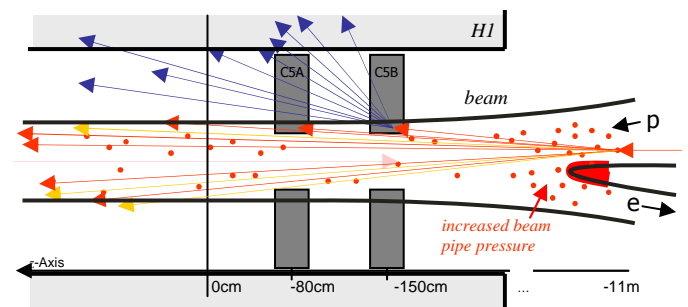

Figure 1: The increased synchrotron radiation background reduces the vacuum quality of the beam pipe mainly in the backward region (incoming proton direction) of the detector. This manifests itself in larger background rates from collision events between protons and rest-gas nuclei, which leads to the observation of hadronic showers from the backward direction [3].

In such collisions, off-momentum particles are produced. These off-momentum particles generated in the backward region may collide with the collimators C5A and C5B, thus creating secondary interaction vertices. These collisions lead to high particle multiplicities in the tracking detectors and represent a large fraction of the background [3].

Induced second interaction vertices at the collimators C5A (-80cm) and C5B (-145cm) and the high number of background tracks arising from beam-gas events in the

backward region ($z = -10.8\text{m}$) necessitate a powerful separation of *ep*- and background events.

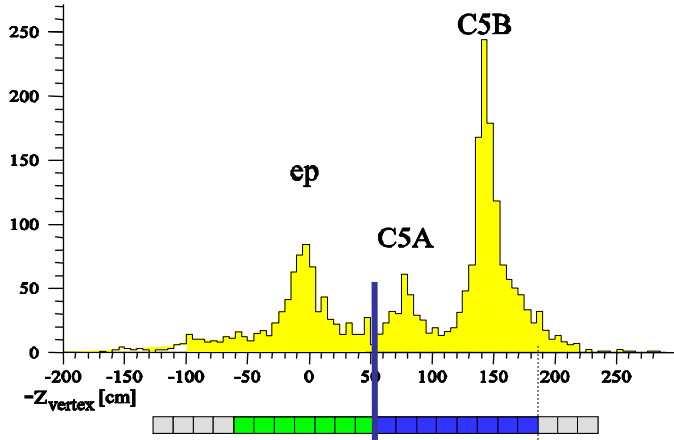

Figure 2: Distribution of events of a luminosity run (in 2002) along z -axis. *ep*-events with a moderate number of tracks around the nominal interaction vertex ($z = 0\text{cm}$) have to be selected by the CIP2k z -vertex trigger system (light grey shaded area in the z -vertex histogram below the distribution ($\sim 50\text{cm}$ to -50cm). Background events with a high number of tracks and interaction vertices below $z = -50\text{cm}$ have to be tagged as background events (dark grey shaded area, veto condition).

In Figure 2 a distribution of events of a luminosity run (in 2002) according to its z -vertex is shown. Most of the events are localized around the nominal interaction vertex ($z = 0\text{cm}$) but there is also a large fraction of events localized at the z -position of the collimators C5A and C5B. A powerful handle to separate both types of events is the calculation of an z -Vertex histogram for each event. In the z -Vertex histogram tracks of an event are sorted according to their origin along the z -axis. *ep*-events are identified by a moderate number of tracks around the nominal interaction vertex ($z = 0\text{cm}$), proton beam background events have a high number of tracks and interaction vertices below $z = -50\text{cm}$.

In the Figure the z -Vertex histogram of the presented CIP2k z -Vertex trigger is shown. It covers a z -range from -235.4 cm to $+125.4\text{ cm}$ segmented into 22 bins with a size of 16.4 cm each. The z -Vertex histogram is divided into two regions. In the so called *ep*-region (shaded in light grey), *ep*-events are expected. Events identified in the background region are accordingly tagged as background events (dark shaded).

The trigger decision contains information about the number of tracks in the *ep*- and background region and the total number of tracks in an event. With this information a good separation between *ep*- and background events (according to the definition given above) is possible.

Due to the high number of tracks to be identified, especially in background events, a detector with a high granularity has to be used. Therefore a set of five cylindrical multi-wire proportional chambers of 2 m length and 40 cm diameter was build, placed in the innermost part of the H1 detector (Central Inner Proportional Chamber CIP2k). It provides a total number of approximately 8,500 cathode readout pads

distributed over 16 ϕ -sectors. The high number of channels offers sufficient granularity to resolve the event structure, even in events with a high track multiplicity. Moreover, sufficient redundancy is provided to ensure efficient operation in the presence of inevitable chamber defects.

Concept of the z -vertex trigger:

Based on this chamber the trigger algorithm was developed. In Figure 3, a conceptual side view of one of the 16 ϕ -sectors of the CIP chamber is shown. The chamber has approximately 120 pads in each layer in z -direction.

These pads are activated by charged particles along their trajectory. The trigger algorithm then identifies tracks from this hit information and sorts them into bins. The tracks in the bins of the z -Vertex histogram are counted and after that sorted either into the *ep*- or background-region.

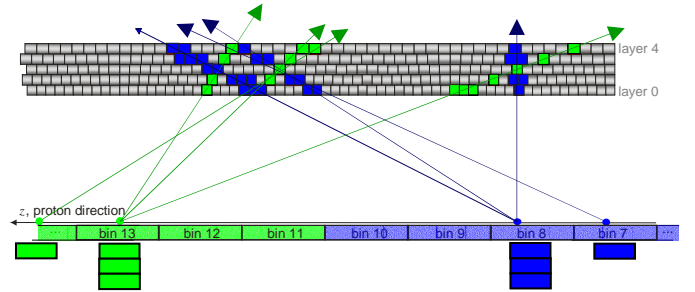

Figure 3: Three steps of the Trigger algorithm

1. Recognition of track pattern and sorting into bins
2. Counting of tracks in bins of z -Vertex histogram
3. Sorting of bins in *ep* - and background region

III. DESIGN OF THE Z-VERTEX TRIGGER

The pipelined H1 first level trigger system (FLT) requires a dead time free calculation of the trigger response, which has to be available $2.3\mu\text{s}$ after the event occurred. This requires a computation of a trigger decision synchronous to the 10.4MHz HERA clock on the first trigger level in a pipelined calculation. While evaluating the decision, the information of each bunch crossing (BC) has to be stored for 32 BCs to be accessible in case of a positive trigger decision.

Flow diagram of the system:

Figure 4 shows the flow diagram of the CIP2k system. The pad information of the 5 layer MWPC is linked to the read-out electronics mounted directly at the detector.

Groups of up to 60 channels are read out, amplified, shaped, digitized, synchronized to the accelerator clock (10.4 MHz) and multiplexed in a specially designed front end ASIC (CIPix). The 16 digital output signals of each CIPix are multiplexed into a single channel using a multiplexer unit (Hewlett Packard HDMP 1032). This digital channel is transferred to the trigger-system using an optical link system. CIPix, multiplexer and optical components are mounted on two eight-layer printed circuit boards (PCBs). Each PCB contains two CIPix and two multiplexer units. One of the

PCBs in addition holds the optical transmitter unit transferring four digital channels. The two boards are interconnected by a strip-line on a capton foil carrier.

The resulting binary data is optically transmitted to the trigger logics in the counting house. There special receiver cards recover the digital outputs of each CIPix. Chamber, CIPix and the optical link system are described in more detail elsewhere [4],[5],[6].

The chamber information is divided into a storage and a trigger path in the trigger system. While the a trigger decision is evaluated, the complete binary data is stored for later readout by the data acquisition system in case of a positive trigger decision.

The trigger system is implemented in large FPGAs (Altera APEX20kE400 [7]) programmed in the hardware description language Verilog. Two types of FPGA based PCBs have been developed.

The **Trigger Card (TC)** holds two APEX20kE400 FPGAs, mounted in a ball grid array (BGA) technique onto an 8-layer PCB, being designed in close cooperation with the electronics workshop of the University of Heidelberg [8].

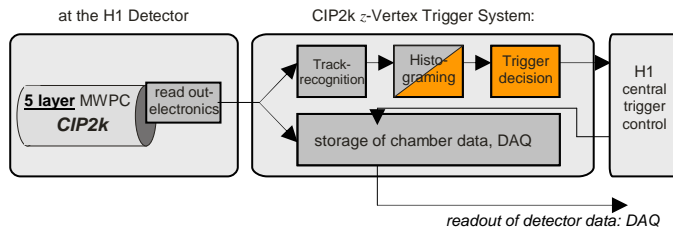

Figure 4: Flow diagram of the CIP2k system: The pad information of the MWPC is amplified, digitized and optically transmitted to the trigger system in the counting house. There it is divided into a storage and a trigger path. While the a trigger decision is evaluated, the complete binary data is stored for later readout by the data acquisition system (DAQ) in case of a positive trigger decision.

It contains both the logic of the trigger algorithm and the storage pipeline for one ϕ -sector of the chamber (ESB blocks in the Altera APEX FPGAs), implemented in ring buffers with a depth of 32 bunch crossings. In case of a positive trigger decision, the chamber information is read out via the VME CPU. Each CPU reads the data from four ϕ -sectors corresponding to four Trigger Cards. One of the CPUs collects the data from all ϕ -sectors and provides it to the H1 data acquisition (DAQ) (via H1 Taxi ring). In total, 16 Trigger Cards are needed to process the complete chamber information, distributed across four trigger crates.

The Trigger Card is fed with the chamber information by a 250-pin input connector. Because one FPGA will not hold the whole trigger algorithm for a complete ϕ -sector, the total amount of pads is divided into two FPGAs. Every FPGA deals with the information of 60 pads of five layers (multiplexed four times). A 90-line interconnect bus connects both FPGAs. Information evaluated by FPGA I is transferred to FPGA II. FPGA II is connected to two SCSI-connectors to deliver ϕ -based data via LVTTTL to LVDS converters (Dallas

DS90LV031). In Figure 5, a schematic view of the Trigger Card is shown.

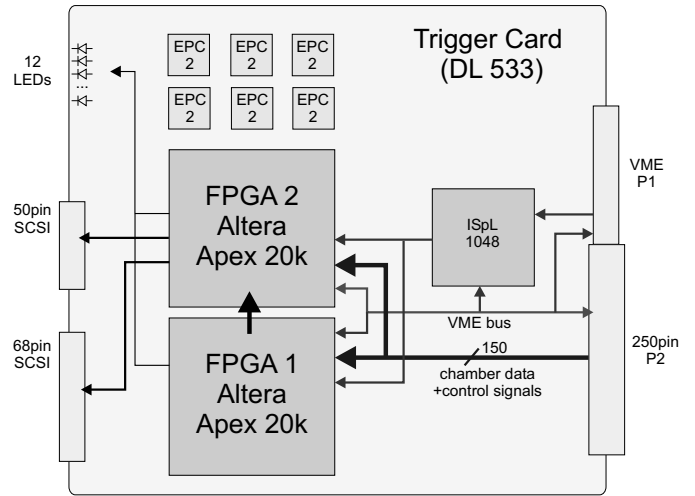

Figure 5: Schematic view of the Trigger Card (TC). The chamber data is linked into each Trigger Card via the 250-pin P2 connector. A 90-line interconnect bus connects FPGA I with FPGA II. Two SCSI connectors are connected to FPGA II, one with 50 pins and one with 68 pins. The VME bus is accessible via the ISpL1048. Programming both FPGAs is possible via six EPC2 devices and VME bus.

The trigger algorithm in each FPGA starts with demultiplexing the hit information in a demultiplexer module (demux.v¹). To avoid an incorrect track recognition due to noisy pads, all pads known to be defect are switched off in the filter module (filter.v). At every start-up of the trigger system, a list of defect pads is programmed into reserved registers in the filter module via a 32-bit VME bus, used on each Trigger Card to manage the data transfer and readout. It is implemented in a Lattice ISpL 1048E PLD [9] (see Figure 5). If a charged particle switches on all the pads or at least a sufficient number of pads belonging to a track pattern, the particle is recognized and its z-position is stored in the trigger module (trigger.v) and counted (adder.v).

The trigger calculation runs synchronously to the accelerator clock and its latency amounts to 960ns.

The second FPGA based PCB is the **Sum Card (SC)**, used to add the ϕ -sector histograms of the Trigger Card to a ϕ -independent histogram.

Unlike the Trigger Card, each Sum Card has a total of six SCSI connectors, five 68-pin micro sub-D (SCSI) connectors and one 50-pin micro sub-D connector. The signal levels meet the LVDS standard. Each 68-pin connector transfers 32 single channels; the 50-pin connector transports 24 channels. All important control signals are given to the Sum Card via the SCSI connectors, programming is possible via a VME interface. In Figure 6 the Sum Card design is shown (schematic view).

¹the file extension .v indicates a hardware description file written in the programming language Verilog

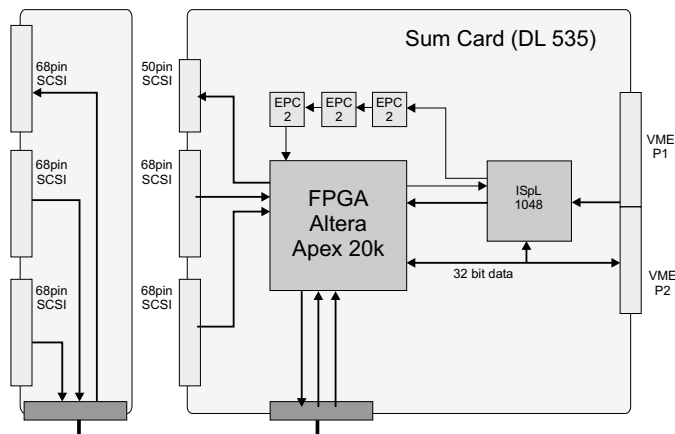

Figure 6: Schematic view of the Sum Card. 6 SCSI connectors are connected to the FPGA. On the left side, the piggy back board is shown, providing three 68-pin SCSI connections. Three EPC2 devices (EEPROMs) hold the configured data in case of a power failure. A 32bit VME bus supports readout and programming of the FPGA.

Each four ϕ -histograms, provided by the Trigger Cards via SCSI cables, are merged into one histogram, covering a quarter of the chamber. Therefore four Sum Cards are used to fulfil this task (Quarter Sum Cards). Each quarter histogram again is given to a Sum Card, the Master Sum Card. It builds the complete z -vertex histogram and calculates the trigger decision as described above.

Aim and hardware description of the CIP2k trigger system are described in [10],[11], moreover a detailed description of the Trigger Card and Sum Card hardware can be found at [12].

IV. OPERATION EXPERIENCE

Tests with minimum ionizing particles have been performed using data accumulated from cosmic rays in summer 2003 in order to check the performance of the system.

The analysis of the CIP chamber and trigger performance is done by selecting events, where a single atmospheric muon crosses the central jet chamber (CJC) of the H1 detector in two sectors opposite in azimuth with a maximum distance of 5 cm from the beam axis. In this way, the chamber response on two track events may be studied. The z -range of the muon sample is limited to approximately ± 110 cm due to the chamber borders of the CJC.

Charged tracks detected by the CJC are extrapolated to the CIP2k chamber pad position (in each layer). It is then checked whether CIP2k pads nearby are active.

In these tests a good correlation of CIP2k hit position and extrapolated CJC tracks has been found. The z -resolution of the chamber is about 2cm, in good agreement with the pad width (~ 2 cm) [12].

Furthermore, correlations between tracks recognized in the drift chamber of the H1 detector and tracks triggered by the CIP2k system have been studied.

This is done by comparing the extrapolated z -position of the muon tracks recognized by the CJC with the tracks identified in the CIP2k trigger. Since the CIP2k trigger does not provide track information of each detected track, the tracks sorted into the bins of the z -vertex histogram have to be used instead.

Each cosmic muon of the selected data sample generates two tracks in the CJC. For each event the z -position at the beam axis of a combined fit of these CJC tracks is compared to the number of CIP2k tracks in each bin of the z -vertex histogram. For an event sample of $\sim 60,000$ events the result is shown in Figure 7.

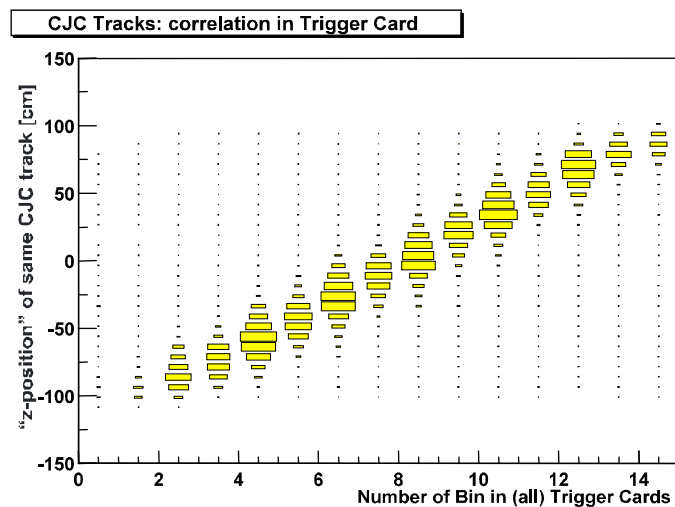

Figure 7: Sorting CJC tracks in CIP2k z -Vertex bins. The z -position of the CJC track is shown versus all bins of the CIP2k z -vertex histogram, having tracks at the corresponding CJC track. The expected correlation is clearly visible.

To get an impression of the z -resolution of the CIP2k z -Vertex trigger, the difference between a CJC recognized cosmic track and the CIP2k bin position of each bin containing tracks, is estimated. It is found to be 16.7 cm in agreement with expectations (bin size = 16.4 cm).

Using a similar method, the single track trigger efficiency is found to be 95% [12].

Due to the high redundancy of the five-layer chamber, defects on the frond-end electronics or the loss of pad information of one layer does not do any harm on the trigger performance if the trigger is set up correctly.

An overview of all plots and discussions of the results of the cosmics run in Summer 2003 can be found at [13].

CIP2k Trigger Performance in ep-Collisions:

The minimal task of the CIP2k trigger is identifying ep-events by detecting at least one particle per event in the central region of the z -vertex histogram near the interaction point to provide a precise timing information. Thus the CIP2k trigger

is used to determine the correct bunch crossing of the ep-event.

Furthermore, the CIP2k trigger should be able to separate background events from ep-events as suggested above. To prove the functionality of the chamber and trigger system in the postulated high multiplicity environment, ep-events are used to test the performance of the CIP2k trigger in its intended field.

The measurements presented here have been performed with beam data of runs taken in October and November 2003.

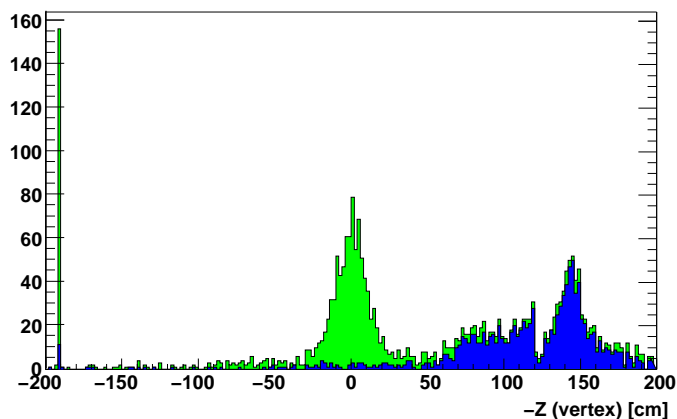

Figure 8: Rejection power of the CIP2k system. Shown is the z -vertex position of events including the background coming from the backward direction, i.e. negative z values (light grey) and the events which are rejected by the CIP2k trigger (dark grey)

In Figure 8, the z -vertex distribution is displayed as seen by a trigger setup, triggering the scattered electron, detected in the Liquid Argon (LAr) calorimeter used to detect high Q^2 Neutral Current Deep Inelastic Scattering NC events. All events are plotted according to its z -position in the same way as shown in Figure 2. The light grey area shows the total number of event triggered in this setup versus the z -vertex position. The dark grey area shows those events, being rejected with the CIP2k veto condition, meaning if more tracks are detected in the backward than in the central region and the total number of tracks exceeds 100 tracks [13],[14].

An excellent rejection power against proton beam background of the CIP2k trigger system was established and can be seen clearly in the Figure.

Presently, the CIP2k trigger is routinely used to reject background events and to provide precise timing information in most H1 physics trigger combinations. Further improvements of the performance for triggering selected physics channels are ongoing.

V. REFERENCES

- [1] H1 Collaboration: "The Luminosity upgrade 2000-2002", see: <http://www-h1.desy.de/h1det/>.
- [2] I. Abt *et al.*, [H1 Collaboration], "The H1 detector at HERA", Nucl. Instrum. Meth. A **386** (1997) 310.
- [3] V. Andreev *et al.* [H1 background working group], "Technical Report on the Beam Induced Backgrounds in the H1 Detector", H1 note H1-IN-606 (10/2002).
- [4] S. Steiner, "H1 CIP-Upgrade: 5-lagige Proportionalkammer", BRS Verlag, Zürich, 1999.
- [5] ASIC Laboratory Heidelberg, "The H1 CIP read-out: CIPix", see: <http://wwwasic.kip.uni-heidelberg.de/Projects/finished.html>
- [6] S. Luders *et al.*, "Compact frontend-electronics and bidirectional 3.3-Gbps optical datalink for fast proportional chamber readout," Nucl. Instrum. Meth. A **484** (2002) 515
- [7] Altera Corporation, "The Altera APEX 20k device family", see: <http://www.altera.com/literature/ds/apex.pdf>
- [8] Electronics Workshop of the Faculty of Physics and Astronomy of the University of Heidelberg, see: <http://pi1.physi.uni-heidelberg.de/physi/ew/Entwicklung.php>
- [9] Lattice Semiconductor Corporation, see: <http://www.latticesemi.com/lit/docs/datasheets/cpld/1048e.pdf>
- [10] M. Urban *et al.*, "First Level trigger for H1, using the latest FPGA Generation", LEB 2000, Krakow
- [11] M. Urban *et al.*, "The CIP2k First-Level Trigger System At The H1 Experiment At HERA," IEEE Trans. Nucl. Sci. **50** (2003) 903.
- [12] M. Urban, "The new z -Vertex Trigger for the H1 Experiment at HERA", PhD Thesis, University of Zürich (2004)
- [13] "Documentation of the CIP2k trigger and DAQ system", list of talks given about the CIP2k trigger system, see: <http://www.physik.unizh.ch/groups/grouptruoel/cipupgrade/cip>.
- [14] F.-P. Schilling, "Trigger setup: CIP background veto applied", H1-Hypernews, Trigger Forum, 24. October 2003 and "Trigger Setup Overview" at the H1 Trigger Meeting, 17th November 2003.