The LHC Experimental Areas

Emmanuel Tsesmelis

LEA Group / TS Department

21 April 2005

General Considerations

- Initial LHC experimental programme consists of 5 experiments installed at 4 experimental areas located at Points 1, 2, 5, 8 (P1, P2, P5, P8)

Not in horizontal plane
1.234% slope

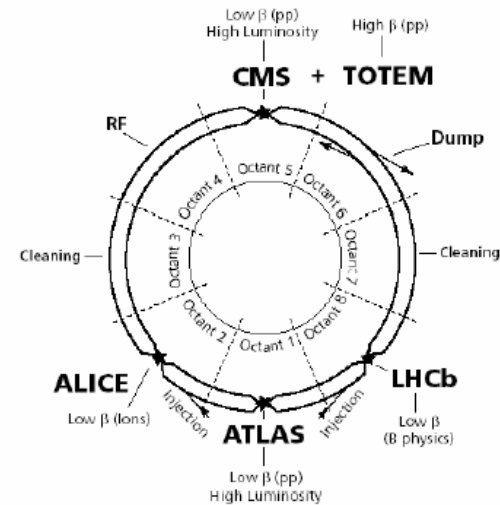
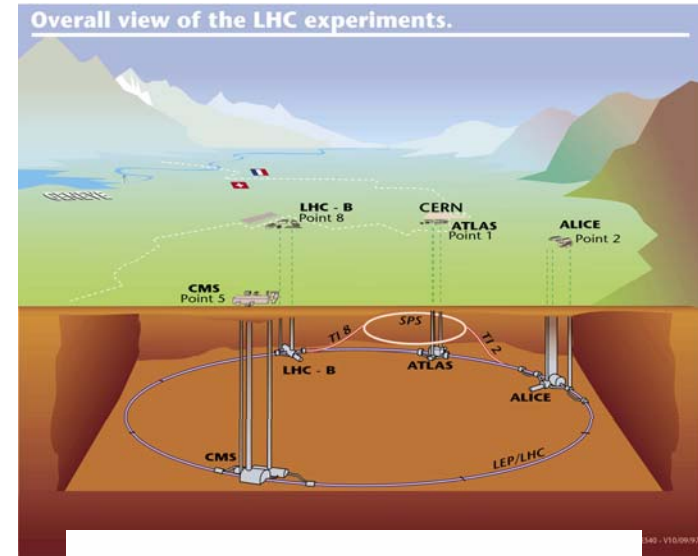

General Considerations

- ATLAS (P1) and CMS/TOTEM (P5)
 - New underground caverns and associated surface facilities
 - Zones designed around each experiment
 - Take into account existing LEP machine structures and keep LEP running as long as possible
- ALICE (P2) and LHCb (P8)
 - Re-use existing caverns and surface buildings used for the LEP experiments
 - Re-arrangement and consolidation of infrastructure left from LEP is required.

LEP and LHC Underground Areas

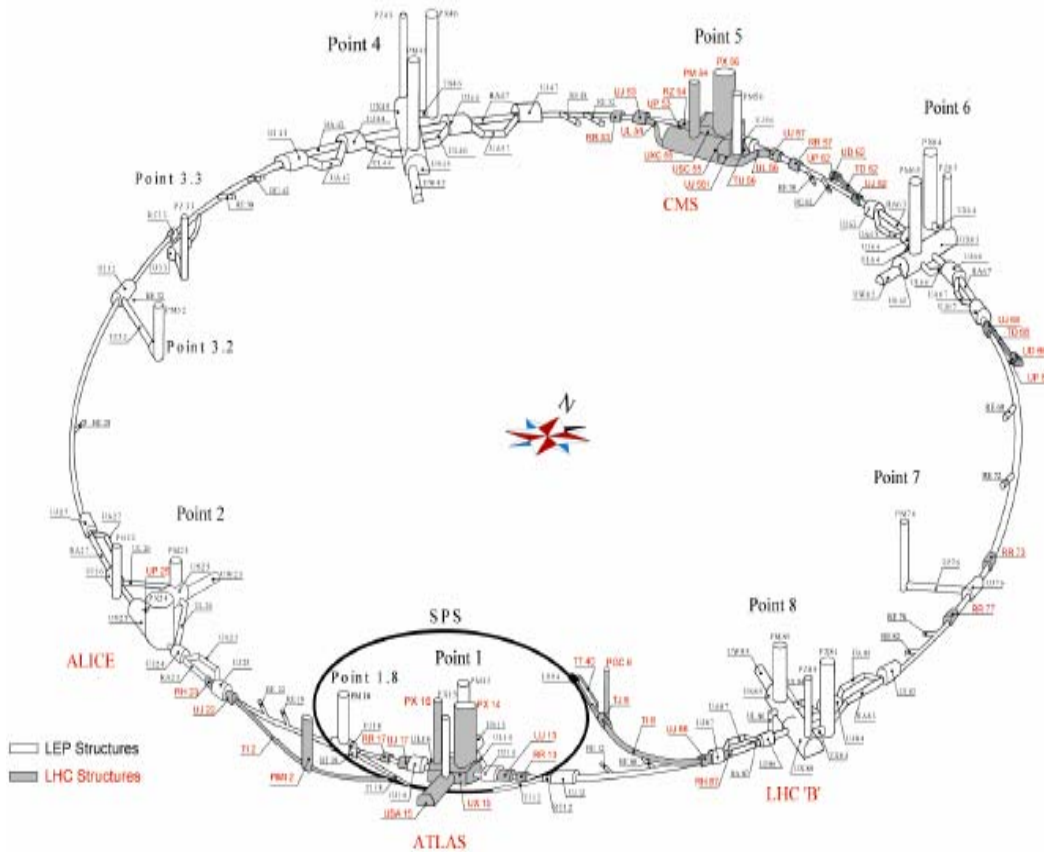

In general:

UX Caverns – installation of experiment detectors

US Caverns – installation of experiment (and machine) services

LEP and LHC Surface Buildings

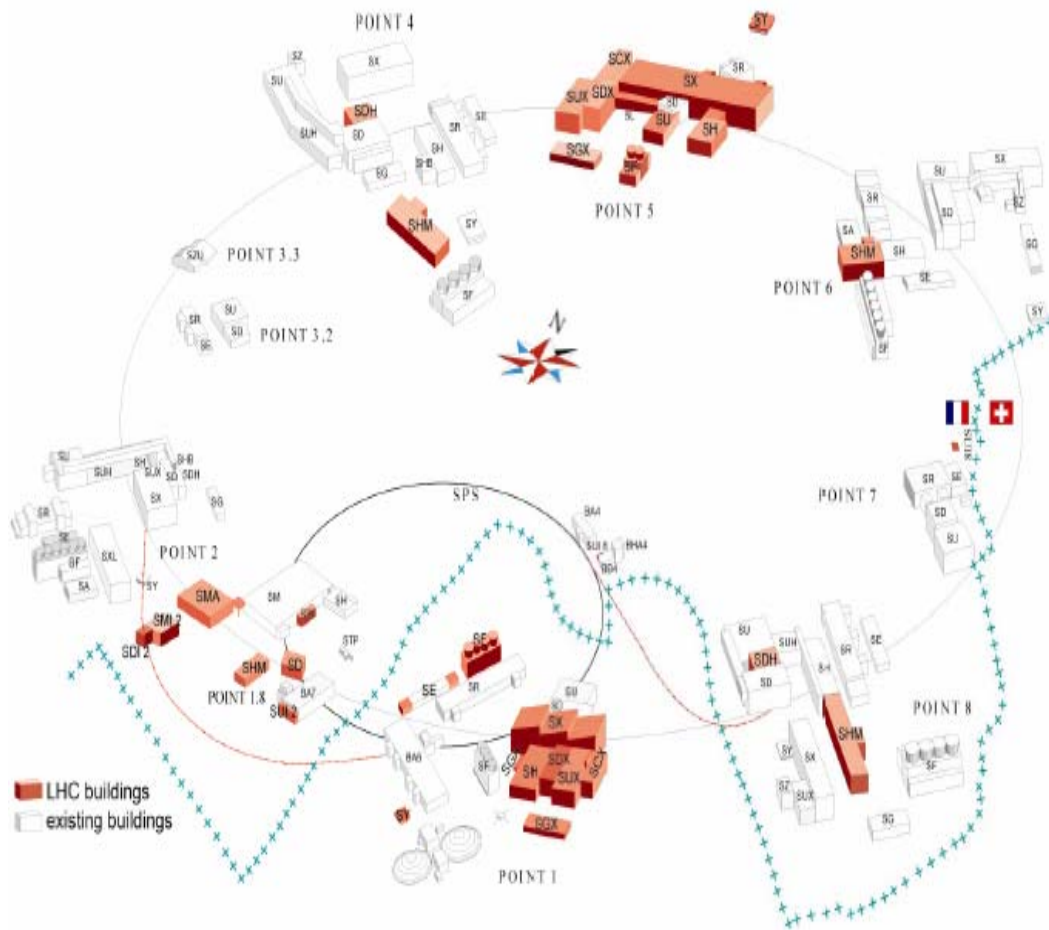

In general:

- SY** Access control to site
- SUX** Ventilation
- SDX** Access to underground areas
- SH** Helium compressor
- SE & SR** Electricity and transformers
- SF** Cooling towers and pumping station
- SGX** Gas storage, mixing & distribution
- SCX** Experiment control
- SX** Detector assembly

The Experimental Area for ATLAS: General Considerations

- Very large volume experiment assembled for the first time in the underground cavern.
 - No surface hall at CERN large enough to make pre-assembly.
- Taken into account in the design of the IR1 experimental area.

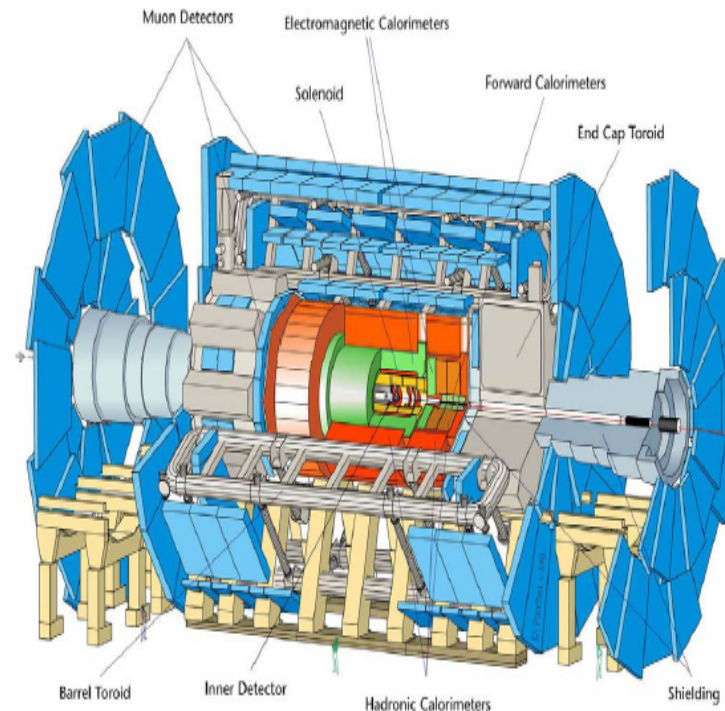

<i>Diameter</i>	25 m
<i>Barrel toroid length</i>	26 m
<i>End-cap end-wall chamber span</i>	46 m
<i>Overall weight</i>	7000 Tons

Cryogenic Infrastructure

- ATLAS detector includes 2 independent systems requiring cryogenic technologies:
 - Superconducting Magnets
 - Barrel Toroid – consisting of 8 coils housed in individual vacuum tanks
 - Two End-cap Toroids – each consisting of 8 coils housed in a common vacuum tank
 - Central solenoid
 - LAr Calorimeters
 - Housed in 3 independent cryostats
 - One barrel cryostat and two end cap cryostats

Surface Experimental Area for ATLAS



The Experimental Area for ATLAS

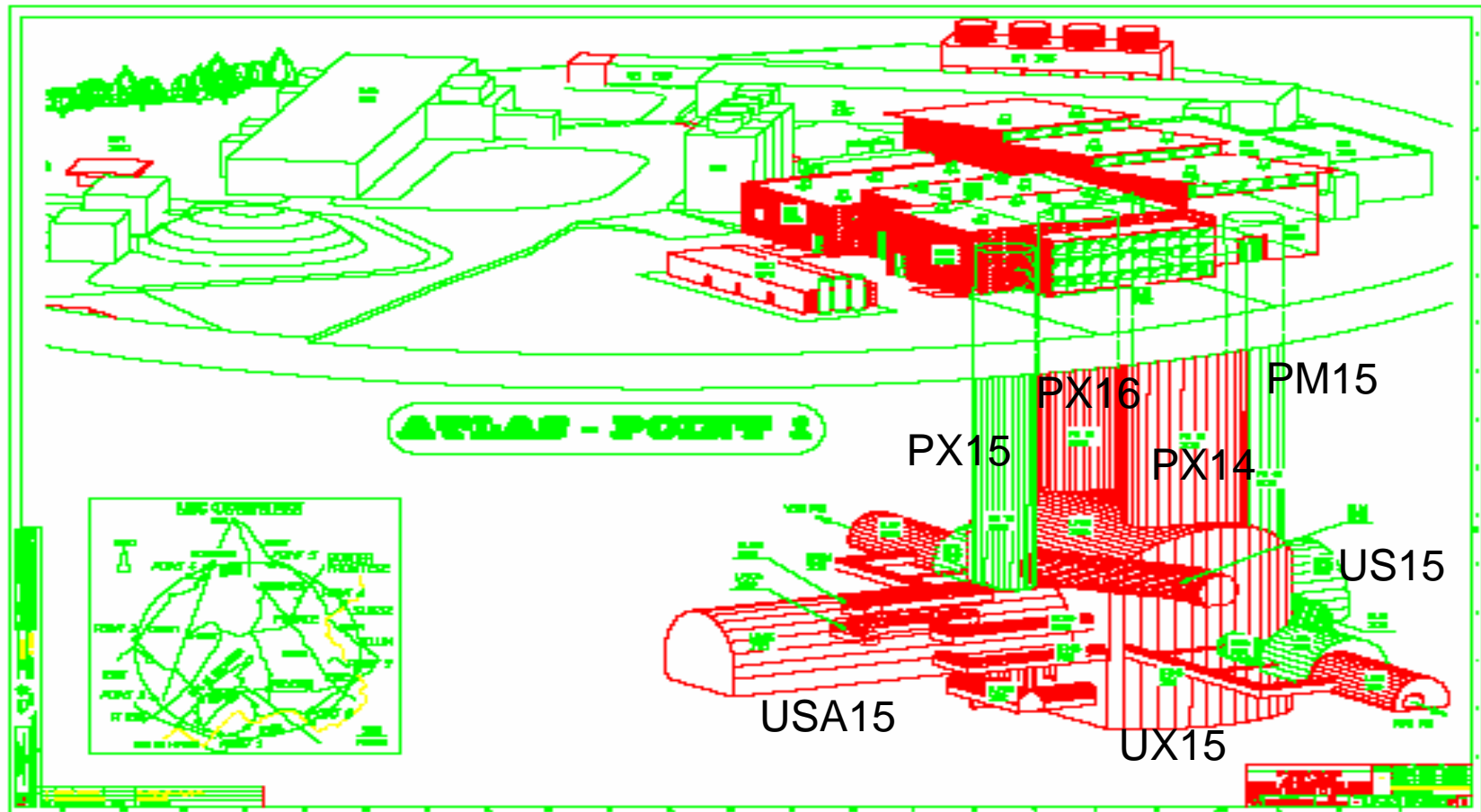

Experiment Cavern UX15 for ATLAS

- Hosts the ATLAS detector
- Located below the SX1 building and linked to it via the PX14 (18 m. \varnothing) and PX16 (12.6 m \varnothing) shafts
- Axis is parallel to the beam tunnel between the existing US15 cavern and PM15 shaft on the one side and the existing PX15 shaft & new technical cavern on the other side
- Dimensions:
 - Max. internal length 53 m.
 - Internal width 30 m.
 - Max. internal height 34.9 m.

Experimental Cavern UX15 for ATLAS

■ Features

- Inner lining of reinforced concrete (1 – 2 m. thick)
- Cavern floor
 - 5 m. thick slab of reinforced concrete
 - Includes several trenches and channels for collection of possible large volume spill of LAr from ATLAS detector
 - Floor slab is horizontal
 - Foundations for the detector feet will be inclined via the so-called 'bedplates' in order to follow slope of the beam (1.234%)
- Top of vertical sidewalls include continuous concrete beams to support crane rails for two 65 t. capacity overhead cranes

Experimental Cavern UX15 for ATLAS

Shortly after reception from civil engineering



During present installation



Service Cavern USA15 for ATLAS

- Located below the pre-existing PX15 shaft
 - With axis perpendicular to the beam tunnel adjacent to the new UX15 cavern.
 - Dimensions
 - Diameter 20 m.
 - Height 13.5 m.
 - Length 62 m.
 - Inner lining of reinforced concrete of 0.6 m. thick
 - Crane beam for 10 t. capacity crane is installed in the apex of the cavern.

Service Cavern USA15 for ATLAS

Helium Cryogenics – Refrigerator Cold Box

- 2 m. wall thickness between UX15 and USA15
 - Serves as radiation shielding in addition to ATLAS detector
 - Incorporates 9 holes (200 mm & 300 mm diameter) to permit routing of trigger cables from the ATLAS detector to the data acquisition racks in USA15.



Service Cavern US15

- Previously existing US15 cavern shared with the LHC Machine
- ATLAS will locate electronics racks, mainly for the Inner Detector power supplies
- Also houses the soap tank for the fire extinguishing system (high expansion foam)
- Cavern is a non-shielded zone and thus not accessible during LHC operation with beam

Electronic Racks

- Racks and crates will be installed around the ATLAS Muon Spectrometer in UX15
- ~100 racks of various dimensions for a variety of components either related to the control of the detector or to safety systems
 - Installed in a hostile radiation environment
 - Not accessible during LHC operation with beam and will have very limited access during short technical stops
- Several hundred racks will be installed in the USA15, US15 technical caverns and in the SDX1 and SCX1 surface buildings

Assembly Building SX1

- Located over the PX14 and PX16 shafts
- Equipped with CERN's highest capacity overhead travelling crane, having two 140t. capacity hoists installed
- Building also includes secondary crane with a 20 t. capacity hoist



Radiation Shielding

- SX1
 - Access shafts covered with shielding consisting of concrete beams 120 cm thick over both shafts
 - Dose level will be substantially below the 1 $\mu\text{Sv/h}$ limit in a surveyed area
 - SX1 will be accessible at all times
 - Dose outside the building at the site perimeter will be below 0.1 $\mu\text{Sv/h}$ required for a public area
- USA15
 - Given wall thickness & geometry of linking galleries, the radiation level estimated to be $< 10 \mu\text{Sv/h}$
 - Allows access to the USA15 cavern during LHC operation with beam (up to ultimate energy & luminosity)
- US15
 - As it is connected to open passages towards the machine, this cavern is only accessible with no beam in the machine
 - Since there will be no activation in this area, access can be granted immediately after beam dump and declaration of appropriate access conditions.

General Considerations for CMS

- Main constraints in design of experimental area given by:
 - Construction and installation of the large solenoid magnet.
 - Necessity to provide adequate and safe working conditions during the fabrication, assembly and installation periods
- Experiment can almost completely be assembled and tested in surface hall
 - Lowered 100 m to underground cavern in large elements of up to 2000 t. each.

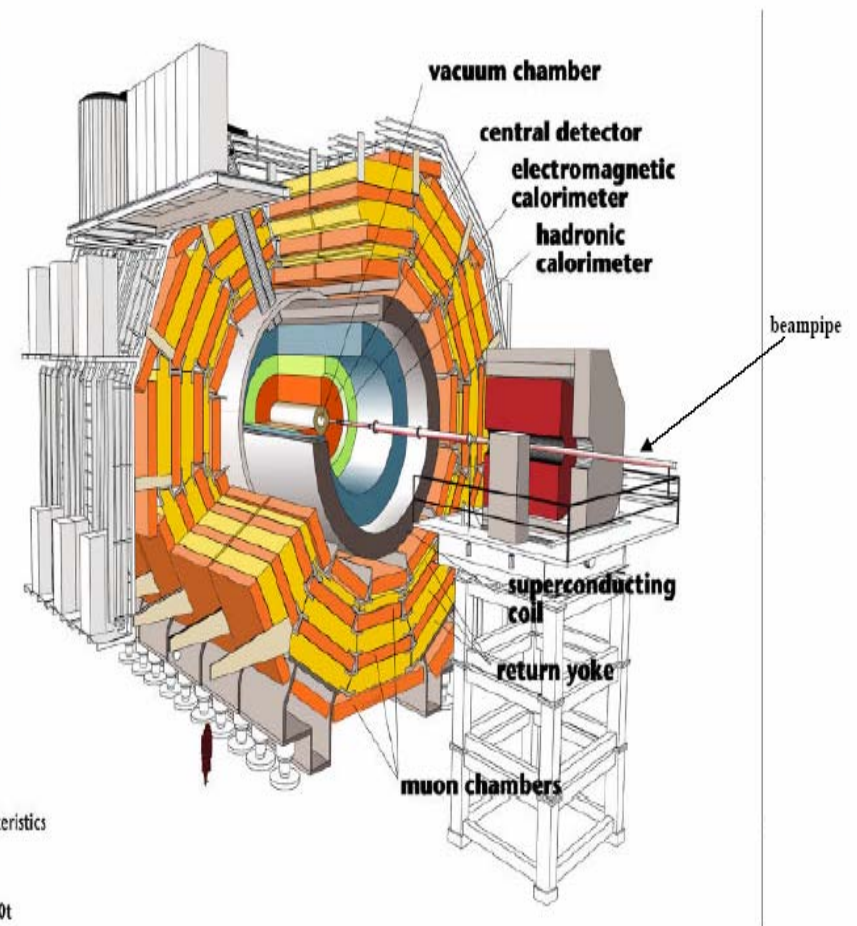

The Experimental Area for CMS

- Carrying out heavy assembly work in underground cavern excluded
 - Would require very large cavern with one additional large access pit and two 80 t cranes
 - Detector construction would have to proceed in series because of the limited length of the cavern
 - Requirements of cleanliness would have to be stricter for the assembly of the superconducting coil
 - Construction of magnet would take longer in underground area than on surface
 - Safety risk for personnel and equipment would inevitably be greater for the underground work

The Experimental Area for CMS

- Alternative solution is to carry out as much detector assembly work on the surface
 - Could be done in parallel with LEP operation and in parallel with construction of underground areas
 - Several sub-detectors (muon chambers and part of the calorimetry) will be installed in the magnet yoke on the surface
 - Saving additional time in the underground areas
 - Rehearse risky operations on the surface
- A larger surface hall is required (temporarily) together with the hiring of heavy lifting equipment for a short time (6 months)

Underground Area for CMS

- Longitudinally-oriented experiment cavern (UXC55) providing space for withdrawal of end-caps
- One access shaft (PX56), centred on beamline, permitting successive installation of large detector pieces from one side of the cavern
- Separate cavern (USC55) parallel to main cavern
 - Radiation-safe distance
 - Shortest possible routing of cables
 - Counting Room & Technical services (cryogenics, gas, power supplies, cooling & ventilation)
- Personnel access shaft (PM54) serving both caverns USC55 and UXC55
- Preservation and use of existing LEP installations (e.g. PM56 shaft)

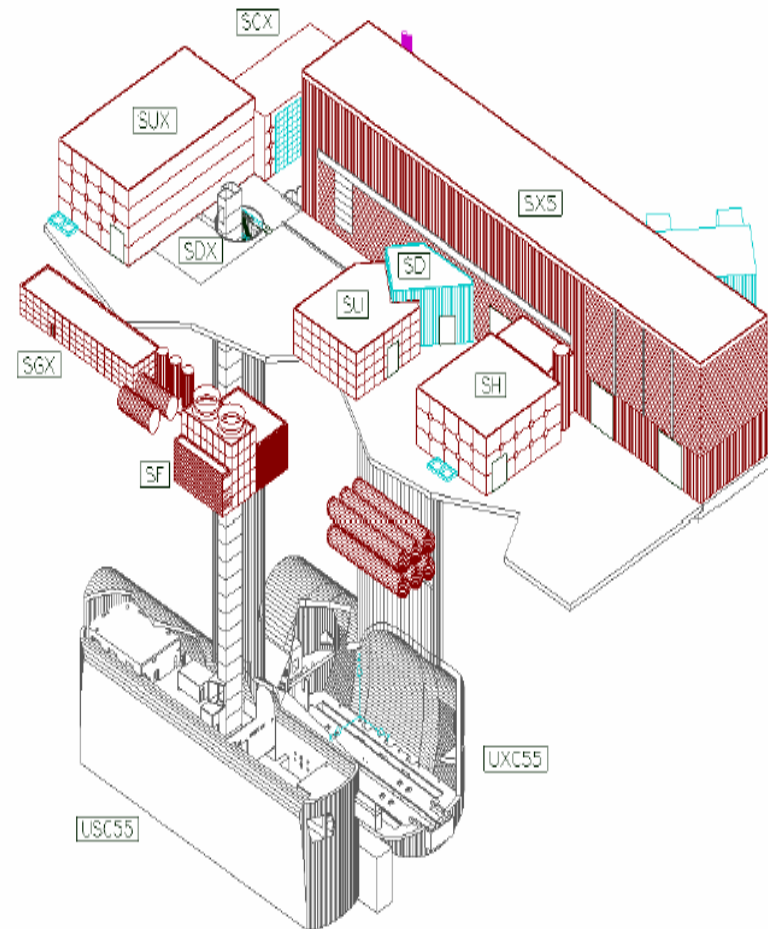

UXC55 Experimental Cavern for CMS

- UXC55
 - 26.5 m. diameter
 - 53 m. long
 - Equipped with 20 t overhead travelling crane
 - Central part of cavern floor lowered by 3 m. to provide access under detector for services
 - UXC55 connected to counting room in USC55 via 3 labyrinths (cables & services)
 - LHC low- β quadrupoles penetrate inside experimental hall and are placed on concrete platform
 - Structure also serves as radiation shielded alcove for HF detectors
- PX56 Main Access Shaft
 - 20.4 m diameter



UXC55 Experimental Cavern for CMS

- Bulk of heat load produced by the CMS detector will be removed by dedicated cooling systems
- Environment in the experimental hall must be stable
 - Ambient air in cavern must be kept at low humidity level (dew point $(9 \pm 1) ^\circ\text{C}$) and temperature stability $((18 \pm 1) ^\circ\text{C})$
 - System of distributed ducts for the injection of air into the cavern installed

USC55 Service Cavern

- Dimensions
 - 18 m. diameter
 - 85 m. length
 - Aligned parallel to UXC55
- Houses counting room and technical services zones
 - The 2 zones are separated by common access shaft PM54 (9 m. diameter)
 - USC55 also houses LHC machine by-pass tunnel
- Counting Room to house ~250 electronic racks in its 2-floor structure
- Technical Services Zone
 - Power supply and cryogenic system for the magnet
 - Part of magnet quench protection system
 - Cooling and ventilation distribution systems
 - Racks for LHC machine



SX5 Surface Building

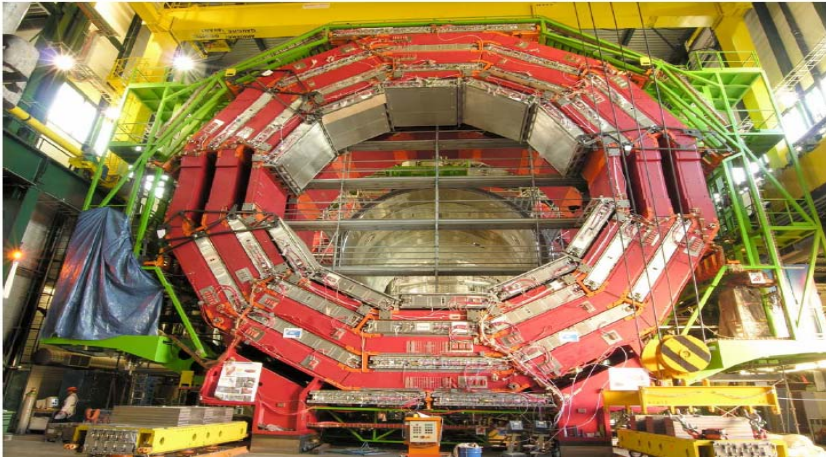

- SX5 built in order to carry out complete assembly and test of CMS magnet on surface
 - Construction of magnet sub-assemblies, too large to be transported by road, requires 100 m. long, 23.5 m. wide building
 - Requires 18.3 m under crane hook (23.5 m building height)
 - Two 80 t overhead travelling cranes
 - General heating and ventilation system

CMS Detector Assembly in UXC55

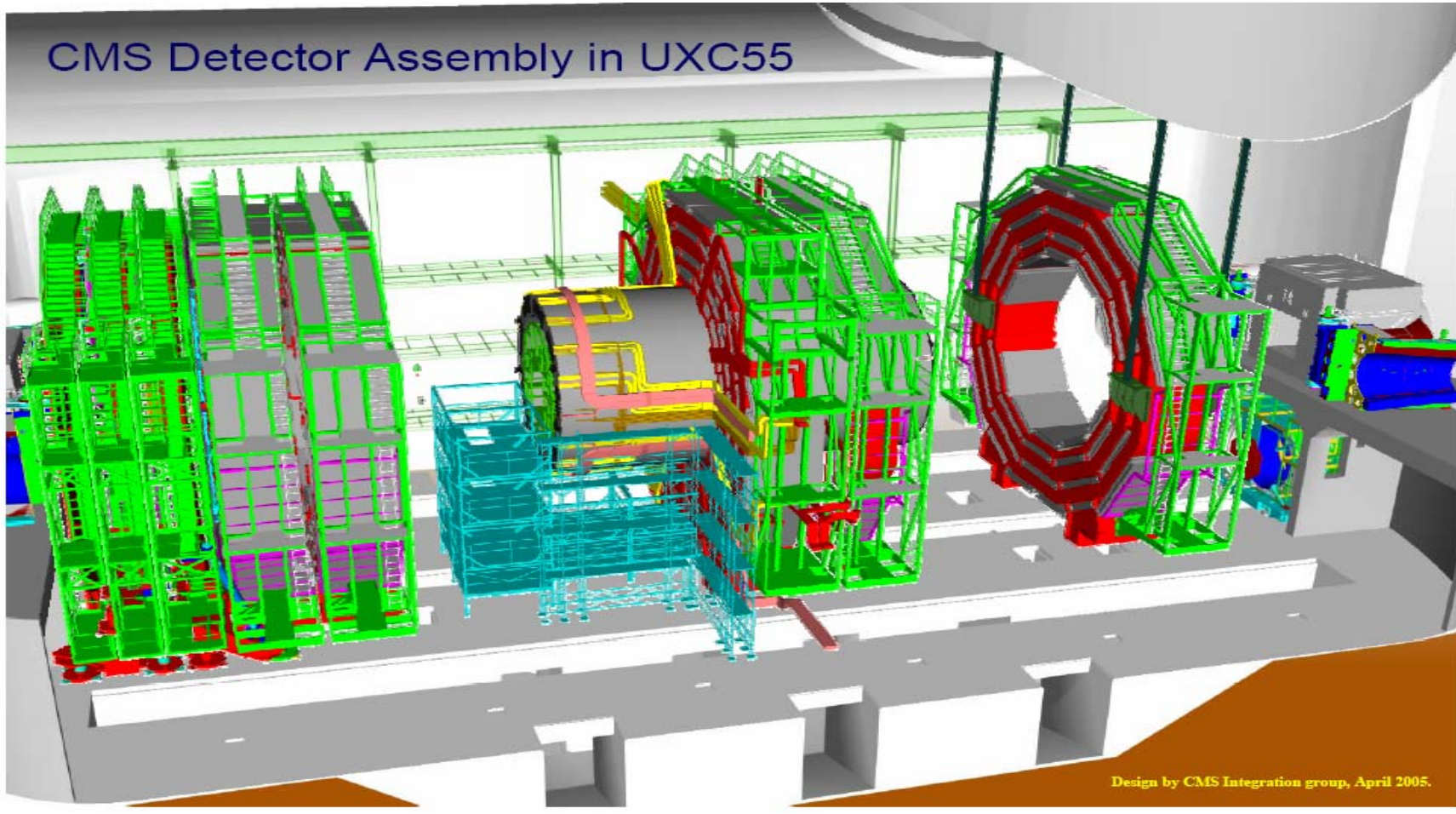

Lowering of CMS Detector: SX5 to UXC55

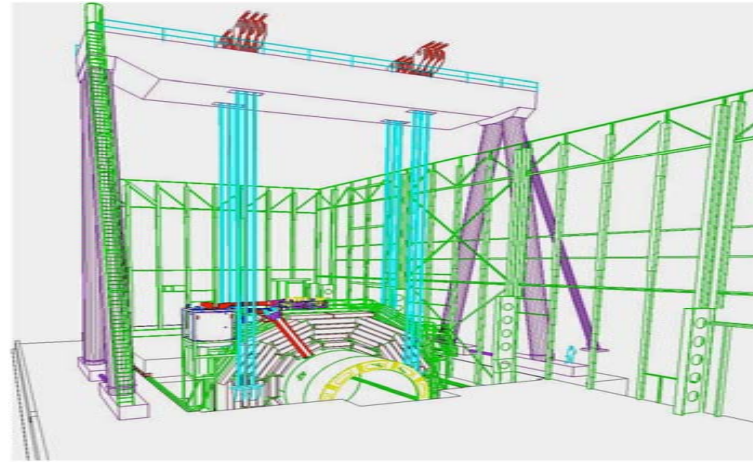

- 15 heavy lifting operations are planned
- Heaviest piece is the central barrel yoke and magnet solenoid
 - 2 000 t in total

Radiation Field

- Unprecedented hostile radiation environment.
- Secondaries from pp-interactions responsible for high radiation background
 - Radiation damage of detectors and materials
 - Personnel radiation safety issues

Radiation Fields

M. Huhtinen

CMS Experimental Cavern

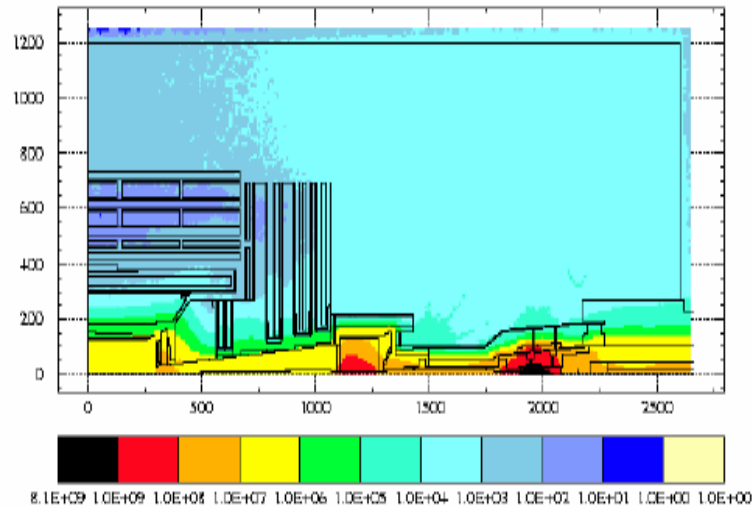

Neutron Flux [$\text{n}/\text{cm}^2/\text{s}$ at $L = 10^{34} \text{ cm}^{-2} \text{ s}^{-1}$]

CMS Experimental Cavern

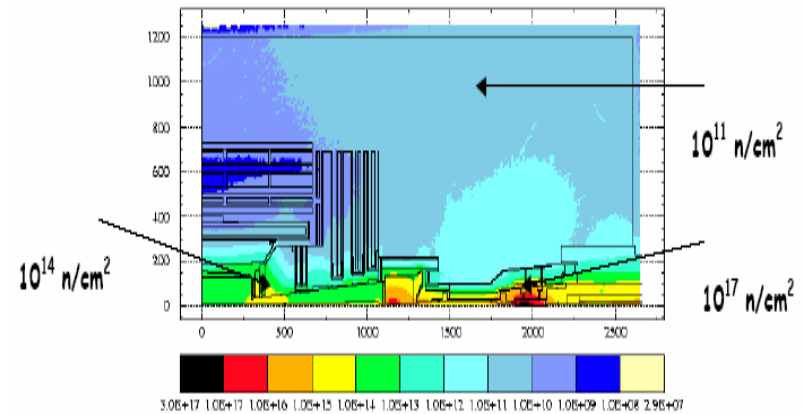

Neutron Fluence $>100 \text{ KeV}$ [n/cm^2 10 yrs LHC operation at $L = 10^{34} \text{ cm}^{-2} \text{ s}^{-1}$]

Results in bulk damage to bipolar devices

Radiation Fields

M. Huhtinen

CMS
Experimental
Cavern

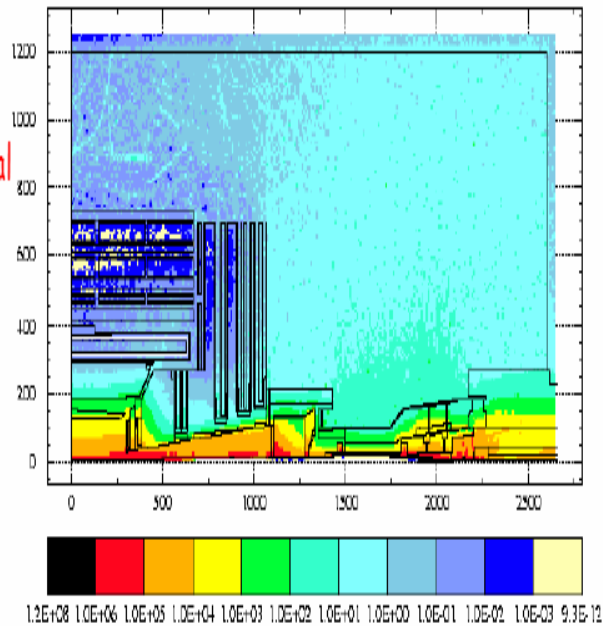

Dose [Gy in 10 years of LHC operation at $L = 10^{34} \text{ cm}^{-2} \text{ s}^{-1}$]

Personnel
Safety

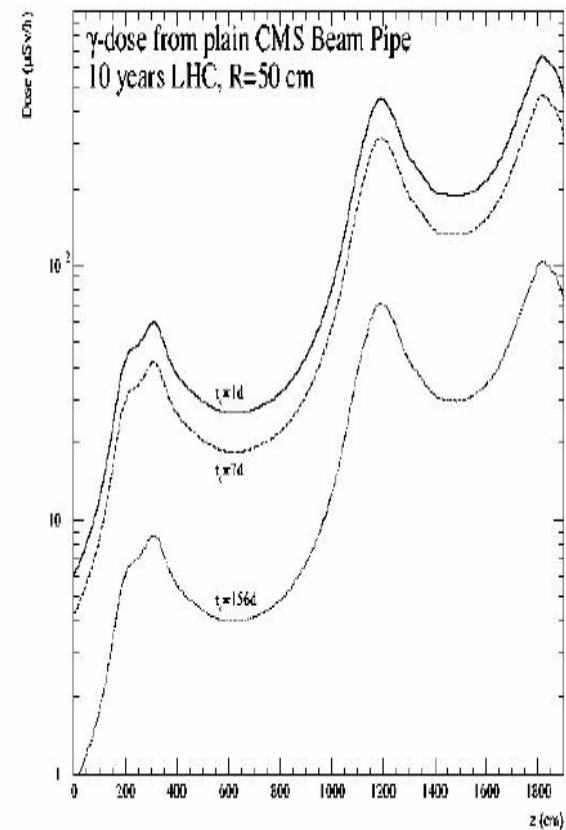

Radiation Shielding

- 7 m. thick separation wall between USC55 and UXC55 caverns will allow service cavern to be permanently accessible as a radiation controlled area
 - Minimum 3 m. required for the radiation shielding
- Main access shaft centred on LHC beam line and a mobile shielding plug of 2 m. thick concrete installed on surface.
- A 3 m. thick shielding door will separate access from the bottom of shaft PM54 to floor of main cavern.



Radiation Shielding

- Shielding required to protect experiments against machine-induced background emerging from the LHC machine.
- Radiation levels in the P1 & P5 experimental caverns are low (**1 Gy/yr**) and both ATLAS & CMS will be rather insensitive to machine-induced background.
 - The rates for muons, which are the only particles that penetrate the shielding from the machine side, are estimated to be below **$10 \mu \text{ cm}^{-2} \text{ s}^{-1}$** .

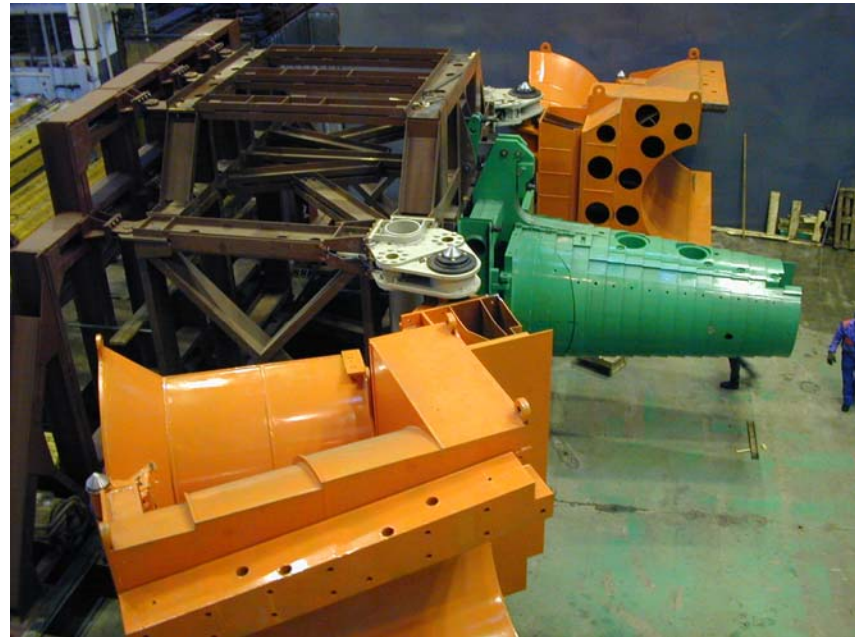

Point 5 Forward Shielding
~2 m Fe-equivalent
Similar for Point 1 – TX1S Forward Shielding

General Considerations for ALICE

- Design of the ALICE experimental area at Point 2 driven by:
 - Re-use of large solenoid magnet built for the LEP experiment L3.
 - Construction of large dipole spectrometer magnet (~ 1000 t.)
 - Room temperature, water-cooled coil
 - Assembled in experimental cavern & installed alongside L3 solenoid

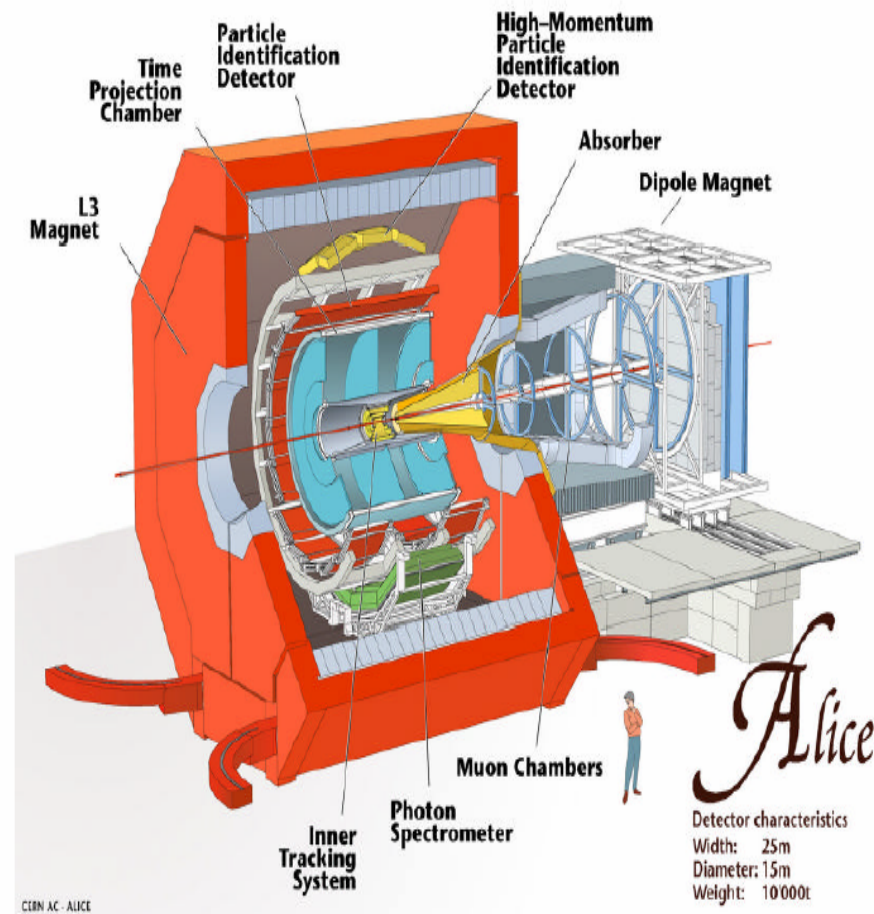

The Experimental Area for ALICE

- Features
 - Main access shaft PX24 is 23 m. in diameter and provides a 15 x 7 m² opening for installation passage and space for counting rooms
 - Counting rooms separated from experimental area by concrete shielding plug
 - Experimental cavern UX25 is 21.5 m. in diameter and was initially equipped with a 40 t. crane
 - UX25 dominated by the presence of the L3 magnet
 - 11.6 m long and 11.2 m. diameter 0.5 T solenoid field

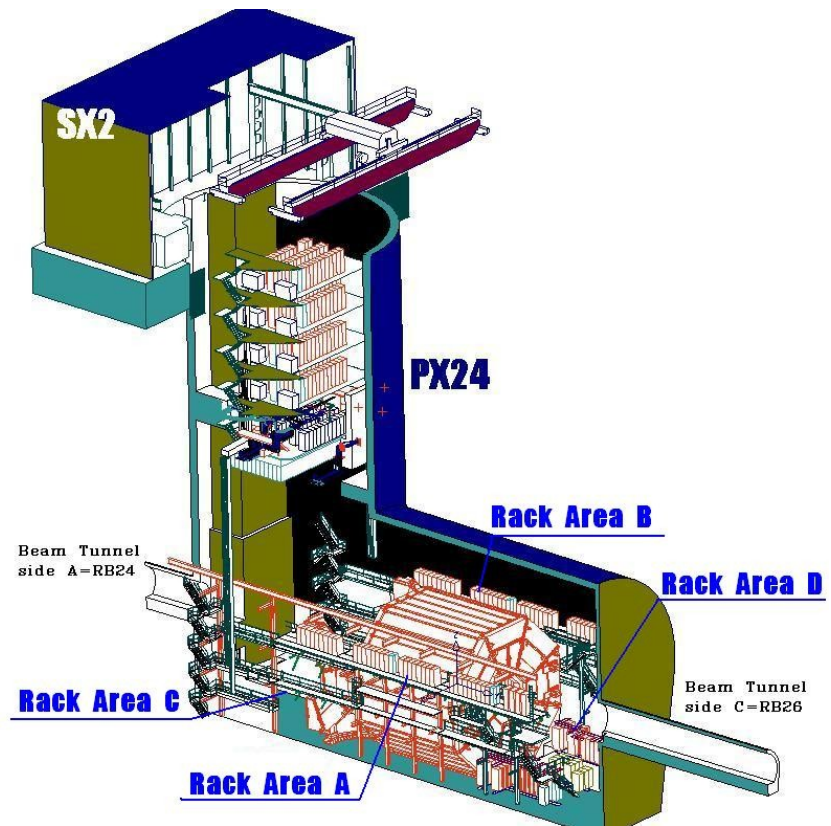

Surface Area for ALICE

- Includes sufficient assembly hall space (SXL2) and storage areas to meet the essential requirements of ALICE
 - No new hall construction necessary
- Main access shaft PX24 covered by SX2 building
 - Equipped with 63 t. gantry crane
- Existing gas distribution building SGX2 can be used without any modification by ALICE
- The main ALICE Control Room (ACR) is situated in the SX2 hall and is divided into the control room area and the computing room.

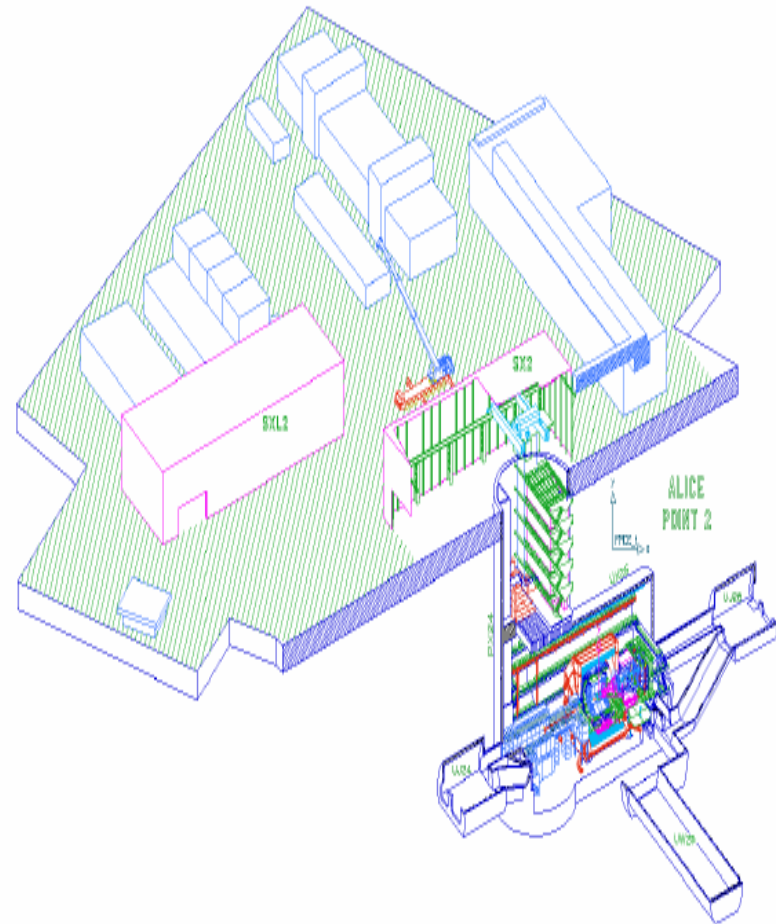

The ALICE Detector at Point 2

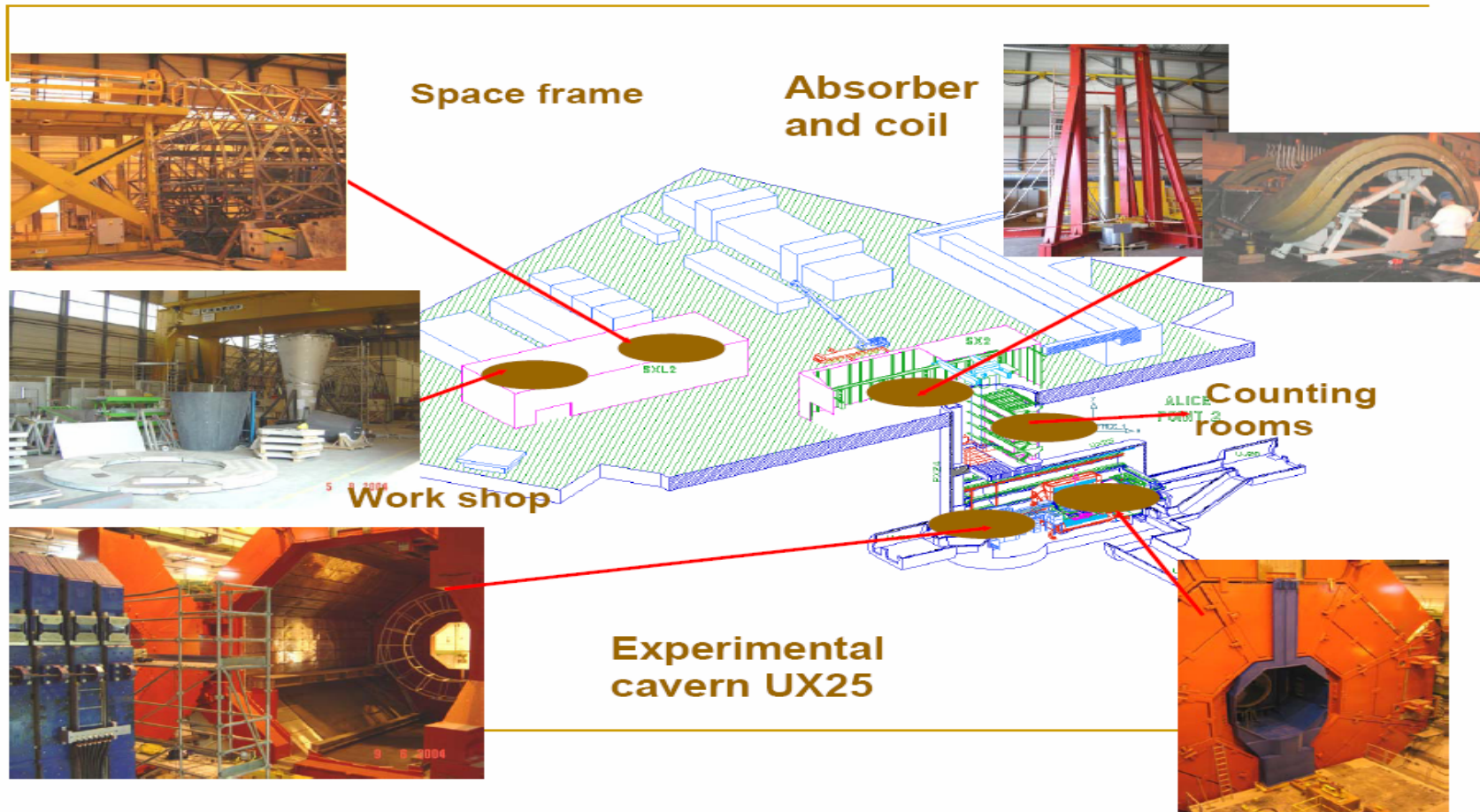

Modifications to Point 2

- Existing capacity of infrastructure installations at Point 2 – cranes, power, cooling and ventilation systems – meet ALICE requirements
- Extensive repair & maintenance programme is necessary to consolidate existing infrastructure and guarantee further 15 year operation

Modifications to Point 2

- Use of PM25 shaft to access LHC tunnel and UX25 avoids construction of second access shaft for UX25
- New 2 x 25 t. crane installed in the UX25 cavern
 - Permits the PX24 shaft to be used to transport large items to the RB26 side of the L3 magnet
- Construction of roof between SA2 and SF2 buildings has created 250 m³ cold storage area
 - Avoids using SXL2/SX2 assembly halls for storage

Radiation Shielding

- More severe radiation environment of LHC compared to LEP requires reinforced radiation shielding (regardless of ALICE) and changes to LEP access.
 - Integration of additional shielding is dominant complication to conversion of experimental area
 - Imposes several constraints on ALICE detector lay-out

Radiation Shielding

S. Roesler, G.R. Stevenson

- Dose equivalent per lost proton for vertical longitudinal section through PX24 shaft
- Loss point at bottom of shaft in first low- β quadrupole magnet
- Multiply by 4.7×10^{14} protons to obtain total dose for full beam loss
- Design constraints for upper part of ACR are fulfilled

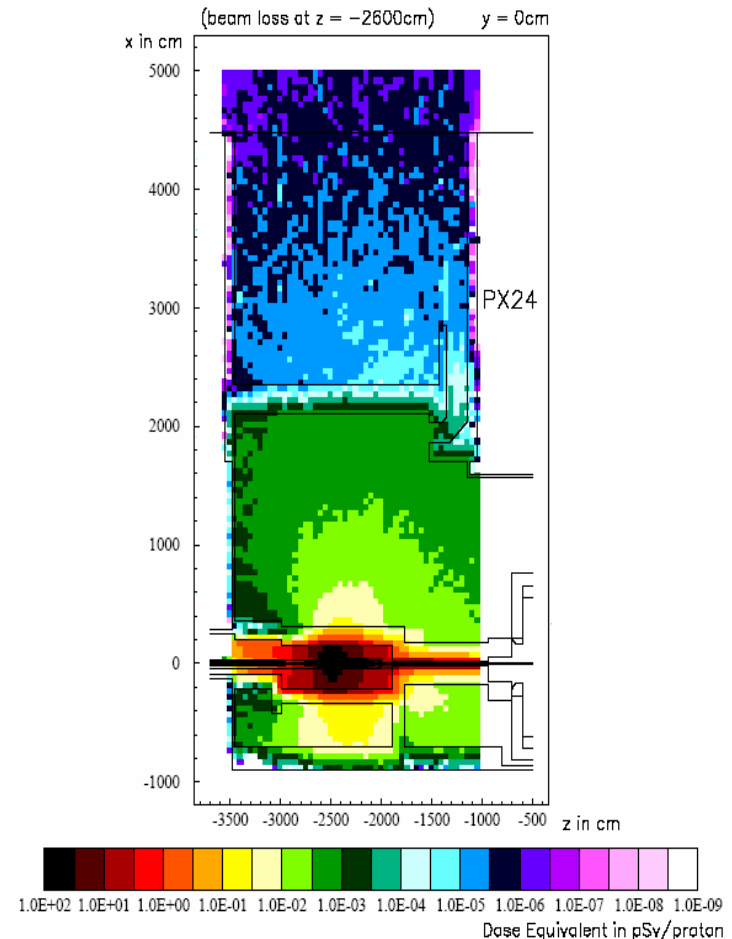

Radiation Shielding

- Additional shielding of the beam line on RB24 side
- Reinforcement of shielding plug in PX24 shaft
- Beam line penetrating into UX25 will be surrounded by minimum of 1.6 m. of concrete

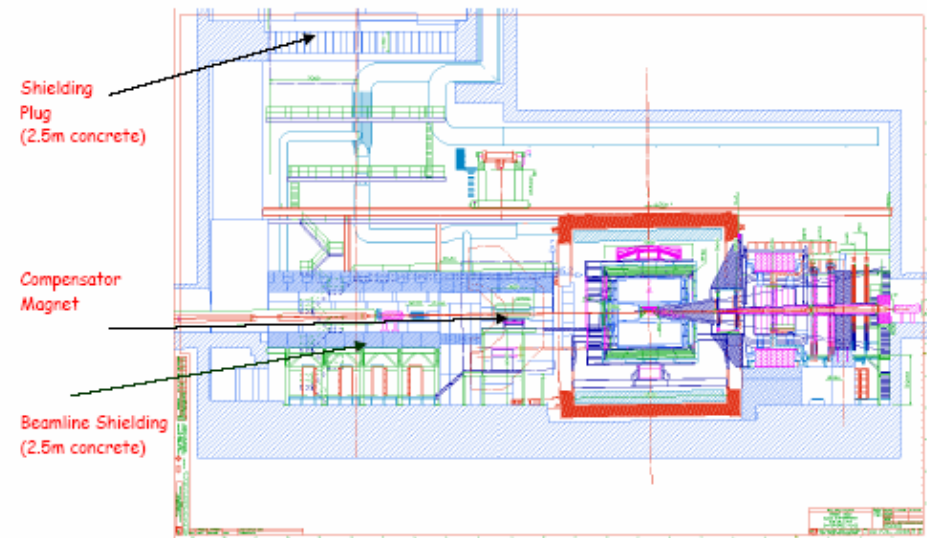

Infrastructure for Services

- All services enter the UX25 via two chicane arrangements incorporated in the circumference of shielding plug separating public area from radiation-controlled cavern.
- The 4 counting room levels in PX24 shaft provide space for 120 racks.
 - Each counting room equipped with water cooling circuits and air cooling capacity of 50 kW

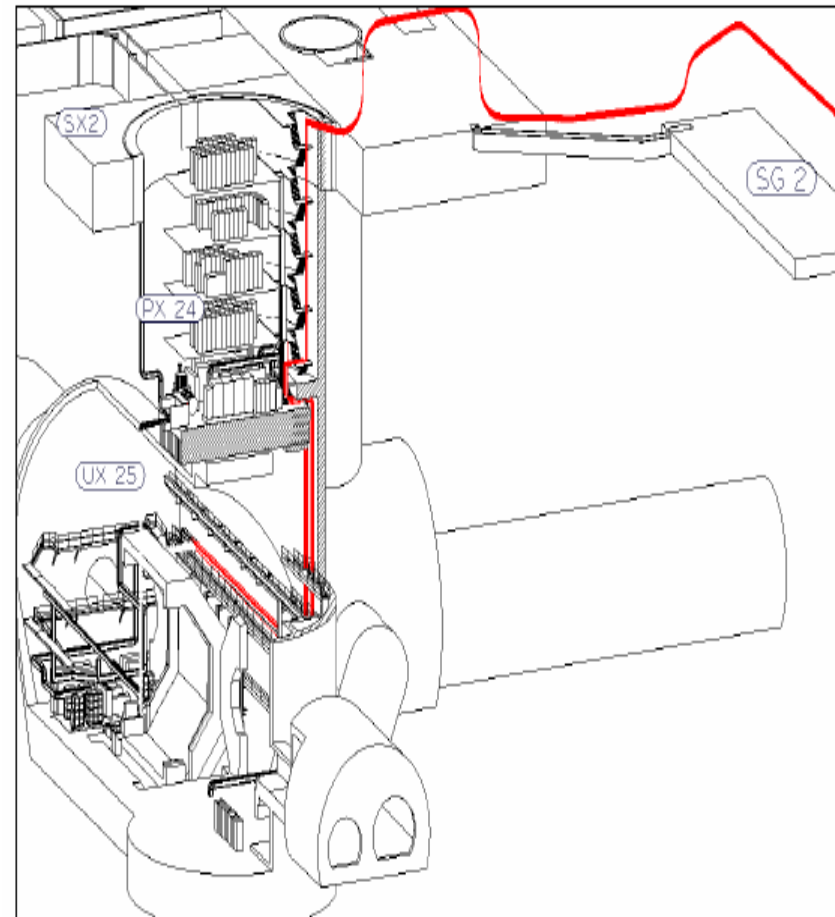

General Considerations for LHCb

- Design considerations for the LHCb experimental area:
 - Smaller experiment similar in size to those installed at LEP
 - Built around a ~ 1000 t. spectrometer magnet of similar size and design to that built by ALICE
 - Magnet will also be assembled and tested for the first time in underground experimental cavern

The LHCb Experiment

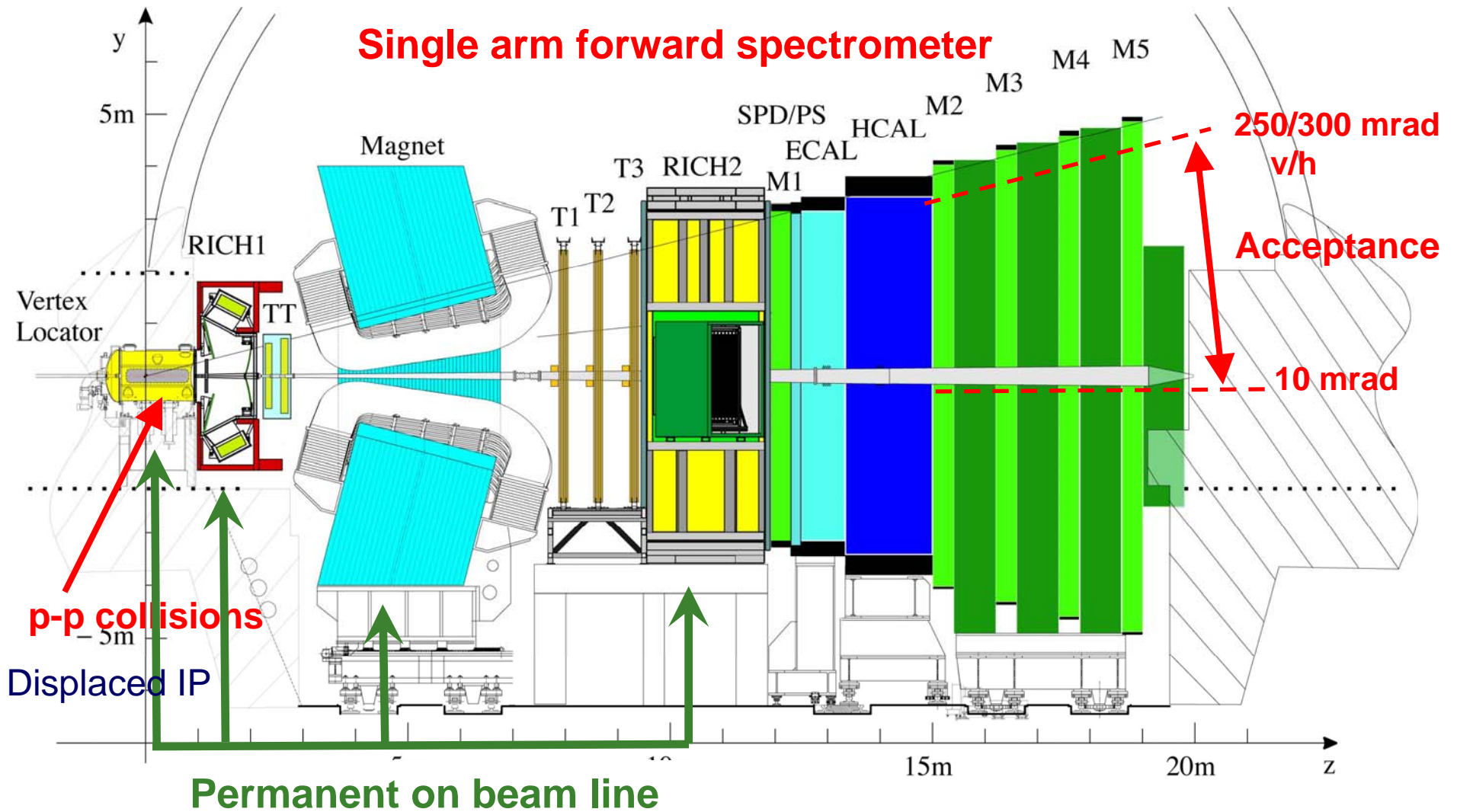

The Experimental Area for LHCb

- Existing UX85 experimental cavern at Point 8 located 110 m. below surface
- Personnel access is via the PZ85 shaft while for lowering of equipment the 10 m. diameter PX84 shaft is used
- Existing cranes include 80 t. hook at PX84 shaft and a 40 t. and 2 x 40 t. hooks in the UX85 area

UX85 Cavern

UX85 AREA

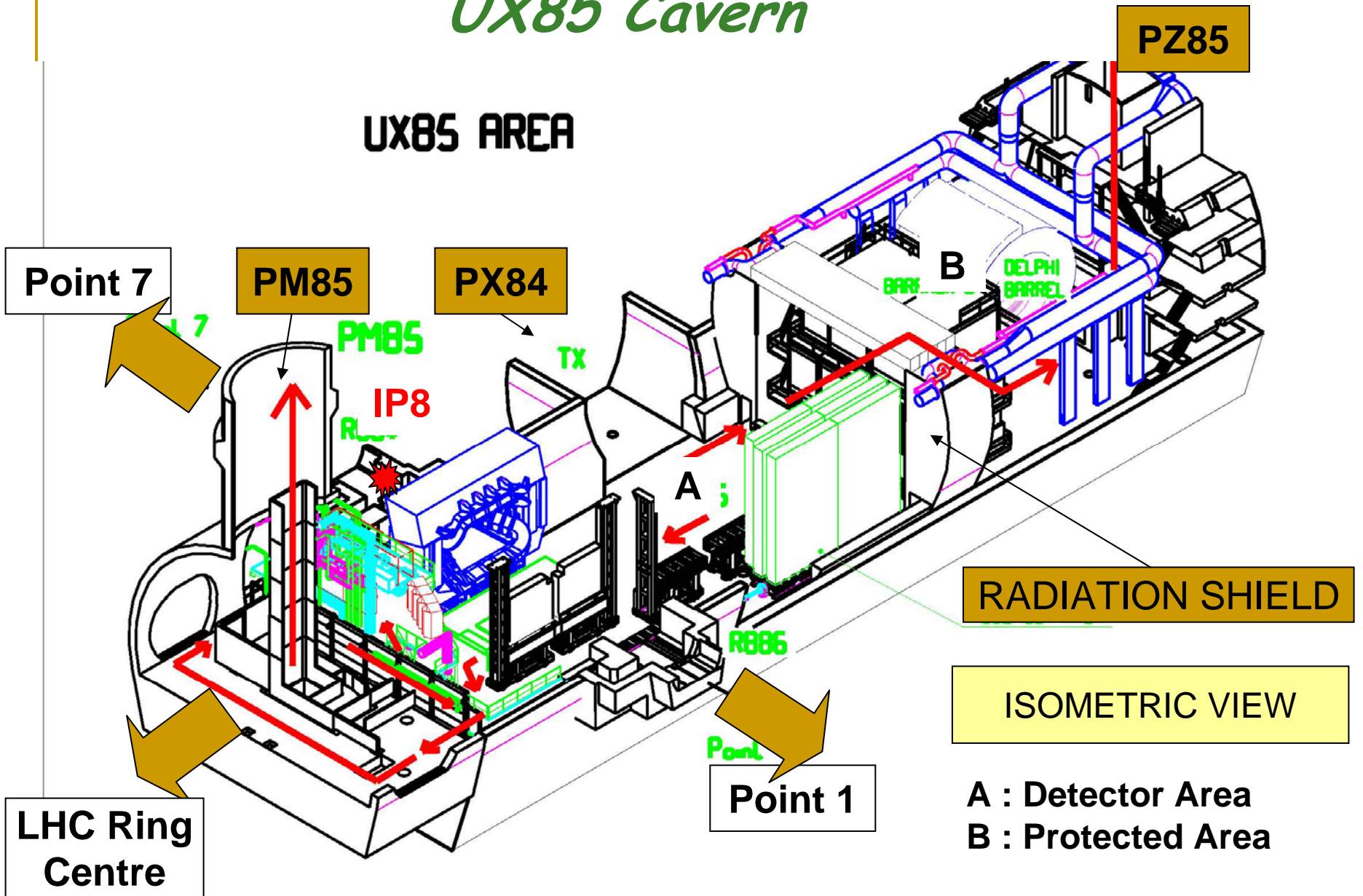

The Experimental Area for LHCb

Concrete modules for radiation shielding



The LHCb spectrometer magnet

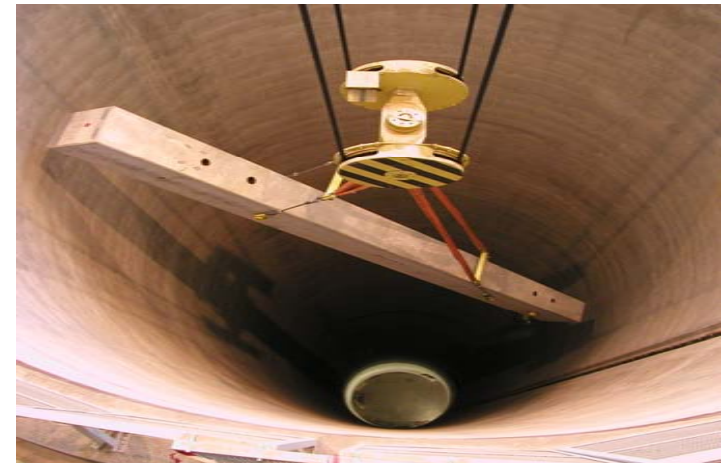

Modifications to Point 8

- All existing infrastructure equipment and facilities, originally provided for the LEP experiment DELPHI, are re-used by LHCb
- Few modifications nonetheless required:
 - Displaced collision point
 - Headwall at the PZ85 shaft end required major consolidation work using concrete structure to replace original metallic structures
 - Installation of cryogenic unit for LHC machine at the end of UX85 cavern beside the LHCb detector
 - UX85 cavern divided into 2 distinct areas to allow access to the mobile counting rooms in PZ85 shaft area
 - LHCb detector area
 - Protected area – counting rooms and control rack location
 - Accessible during LHC operation with beam

Radiation Shielding

- 3 m. concrete wall between the LHCb detector area and protected area is needed as a minimum radiation protection against total loss of a maximum intensity LHC beam
- Modular shield consisting of 3000 t. of concrete installed
 - Includes provision for the passage of general services, detector services and cabling to the LHCb detector
 - Includes large movable central part

LHC Machine Cryogenics

- Two large LHC machine cryogenic components located at the end of the UX85 shaft close to the US85 machine service area
 - QUI interconnection box & QURCA cold box for LHC Octant 8
- Their implementation in UX85 respects the space required for maintenance of the LHCb Muon Chambers



Safety at the LHC Experimental Areas

- Area safety installations designed to provide global protection of surface and underground areas independently of dedicated safety installations needed for the experiment installations.
- Design of experimental areas incorporates several specific safety aspects:
 - Fixed gangways and staircases for easy access to all levels
 - Emergency escape routes
 - Smoke extraction in case of fire
 - Radiation shielding
 - Water flooding detection
 - Removable platform providing protection at bottom of PX56 shaft
 - Fire prevention and fighting system
 - Choice of material, permanent inertion and sniffer systems, hydrants, fire extinguishers, water mist system and a high expansion foam system (P1 and P5)

Safety at LHC Experimental Areas

- Air conditioning
 - Concept, size and mode of operation of air-conditioning systems for experimental areas designed to take into account interconnections amongst underground structures and required accessibility.
 - Air-conditioning systems will perform heating, ventilation, air cooling and safety functionalities (smoke control and gas extraction)
 - Various emergency scenarios studied – for example
 - In event of gas leak or detection of smoke, the flow of air in UX15 and in USA15 can be increased from 45 000 m³/h to 90 000 m³/h while gas extraction systems continue to remove 21 000 m³/h from the lowest part of the cavern.

Safety at LHC Experimental Areas

- Oxygen Deficiency Detectors – for example
 - Presence of large quantity of CF_4 gas in the RICH-2 detector requires appropriate safety devices to be installed locally
 - Oxygen Deficiency Detectors beneath the RICH-2 detector will trigger an alarm in case of a serious CF_4 leak

Experimental Beam Pipes

- The beam vacuum system must fulfill the many requirements of the LHC experiments, whilst ensuring the safe operation of the machine
- LHC General Requirements:
 - Provide sufficient mechanical aperture to allow unobstructed passage of the two beams in all foreseeable operating conditions
 - Compatible with the ultimate LHC performance
 - Must not induce beam instabilities due to impedance, electron multipacting or other beam related effects

Experimental Beam Pipes

- Experiment General Requirements:
 - Small diameter so that first pixel layer installed as close as possible to beamline for good secondary vertexing
 - Maximum transparency to particles
 - Mass minimization and high radiation-length materials
 - Adequate dynamic vacuum to prevent excessive beam-gas background
 - Conformity with thermal environments of the surrounding detectors
 - Removable bake-out heating elements

Experimental Beam Pipes

- Requirements on Vacuum by Experiments
 - ATLAS, CMS and LHCb have requested an average total pressure better than 10^{-8} to 10^{-9} Torr inside the beam vacuum system during operation to limit beam-gas interactions
 - In the case of ALICE, the request is for 10^{-11} Torr driven entirely by the background rate and associated occupancy levels in the TPC

Experimental Beam Pipes

- Beampipe Requirements:

- Need a continuous vacuum chamber, which must:
 - Be clean and evacuated
 - Have a smooth conducting surface
 - Be thick enough not to buckle
 - Vacuum chamber requires supports, pumps, bellows, flanges, valves and vacuum instrumentation and access

- Materials Used

- Be (toxic!), Aluminium, Stainless Steel

Experimental Beam Pipes

- Gases found in Ultra High Vacuum systems are:
 - H_2 , CH_4 , H_2O , CO , and CO_2
- A variety of pumping devices are needed:
 - Sputter ion-pumps - pump all the above gases.
 - Titanium sublimation pumps - pump all gases except CH_4 and noble gases
 - NEG pumps (strips and sputtered) - pump all gases except CH_4 and noble gases

CMS Experimental Beam Pipe

• IP to Q1

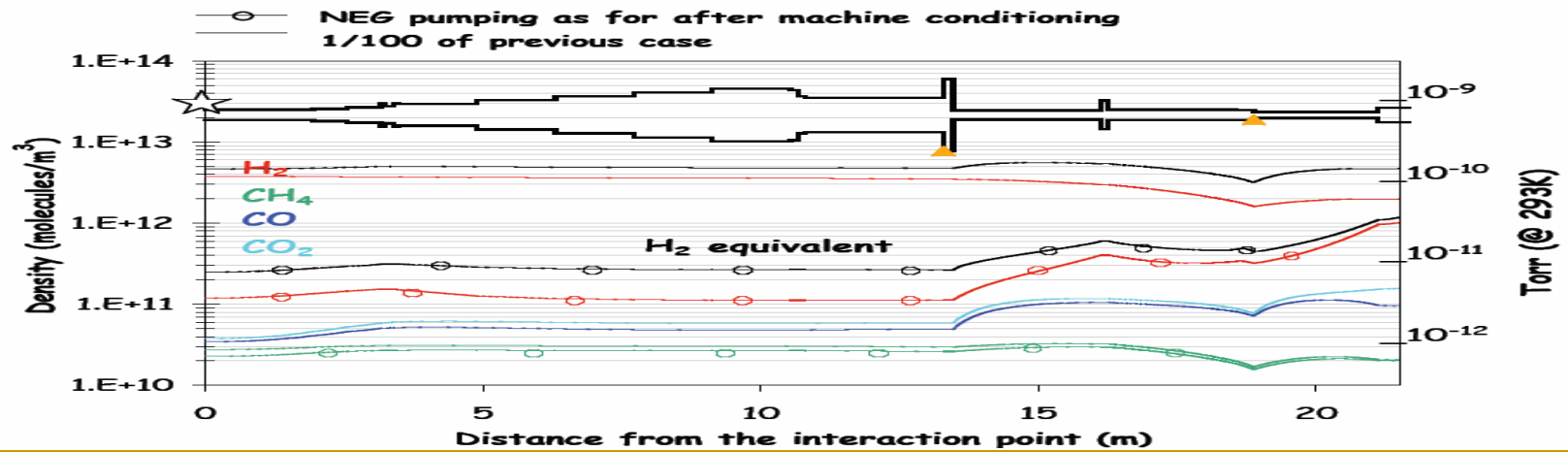
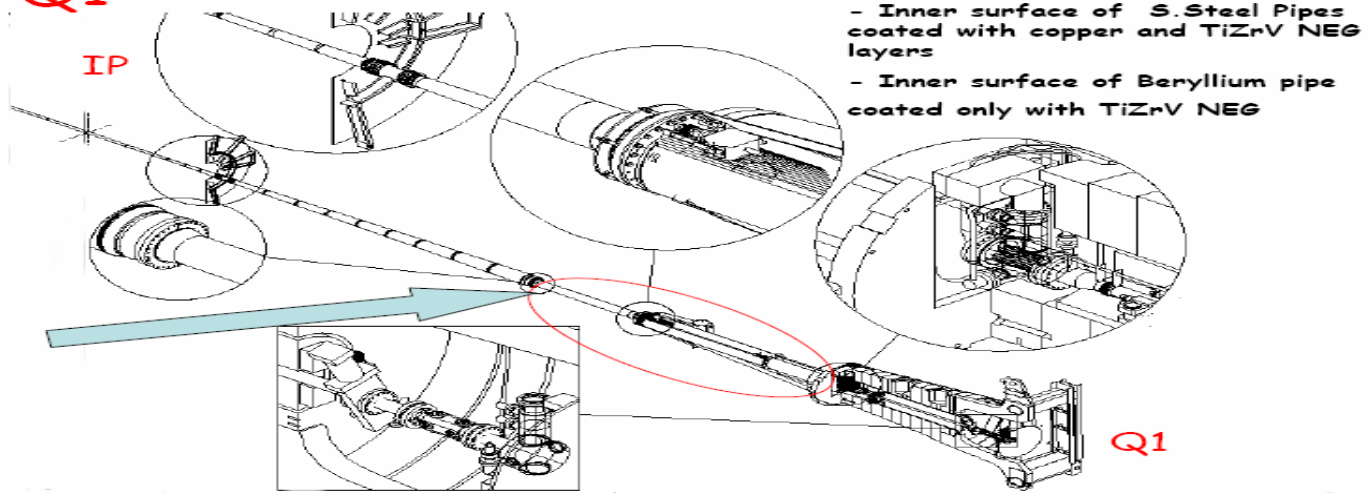

Multipacting

- Potential problem for the LHC
 - Bombardment of the vacuum chamber wall by energetic electrons could produce gas desorption and excessive pressure rise.
- LHC operation with 75 ns bunch spacing limits multipacting.

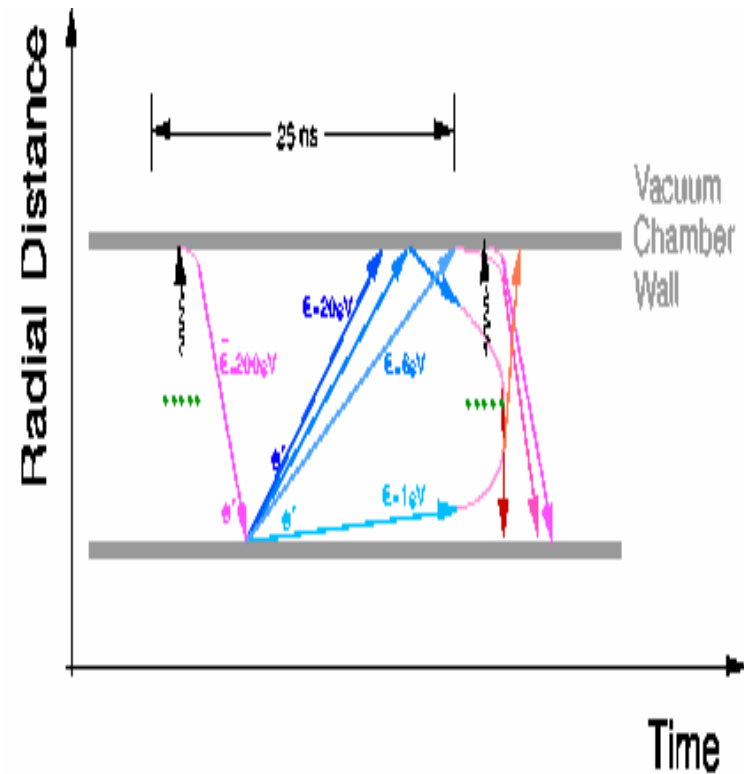

Detector and Experimental Area Survey

- Survey provides the spatial coordinates of the fiducial and external points of the detectors and experimental areas in a reference system related to the LHC machine geometry
- The survey will:
 - Ensure components are located properly during their installation
 - Provide geometrical information on the differences between the `as built' and design positions of any detector

Detector and Experimental Area Survey

- **Survey Reference Network**
 - The cavern reference network is the basic structure to locate the detectors with respect to the LHC geometry
 - Consists of reference marks (foldable brackets and removable plugin tripods) on the UX cavern walls
 - This geometry will be permanently installed in the cavern by a stretched wire and a hydrostatic line linked to the machine elements via the survey galleries (at P1 and P5)
 - Rods embedded in the bedrock in the UJs will provide an absolute reference point in altitude
- The global error budget for any spatial fiducial mark in the experiments with respect to the machine geometry is about 1 mm rms

Detector and Experimental Area Survey

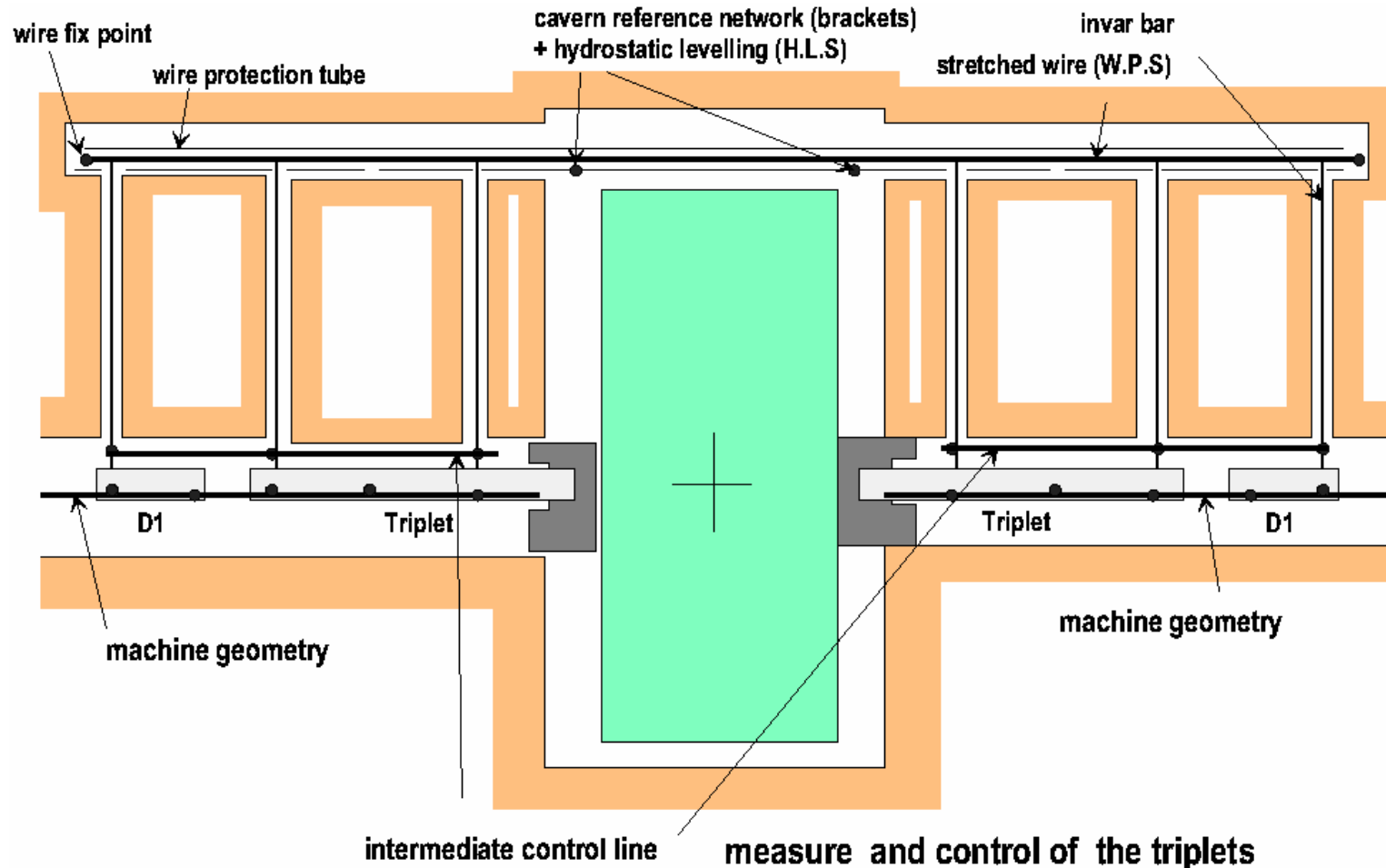

Conclusions

- A major effort is currently well-underway at CERN to deliver the experimental areas to the LHC experiments
- The installation schedule for the experimental areas is consistent with the goal of recording first collisions at the LHC in the Summer of 2007
 - Recall that according to the present master planning of the LHC installation, the detectors and experimental areas, together with the required radiation shielding, are to be closed and the experimental beam pipes are to be in place, conditioned for beam and under vacuum by the end of June 2007

Acknowledgements

- Several CERN teams from various Departments, from contract companies and from the experiment collaborations are working together to prepare the experimental areas
- A big thanks to all !