Hard Probes of Hot and Dense Matter

Concepts
Formalism
Applications
Challenges

B. Müller, Hard Probes 2004, Ericeira, Portugal

The HPC Manifesto

H.Satz & X.-N. Wang: *Int. J. Mod. Physics A 10 (1995) 2881*

- For viable collision studies, at least part of the interaction must be accessible to a perturbative treatment, and this assigns a very special role to hard processes in hadronic interactions.
 - The quark-gluon plasma, predicted by statistical QCD, consists of deconfined quarks and gluons of high density. To check if the early phases of nuclear collisions have, indeed, produced such a plasma, sufficiently hard probes are needed to resolve the short distance nature of the medium.
 - In order to use them for this purpose, we should first understand the basic process, in the absence of a medium, and then check what modifications each basic process experiences in confined hadronic matter. After these two “normalization” steps, we would be prepared to look for parton deconfinement.
-

HPC Benchmarks I

- **Parton distribution functions**
 - A.D. Martin et al., *IJMP 10 (1995) 2885*
 - H. Plochow-Besch, *IJMP 10 (1995) 2901*
 - **Drell-Yan production**
 - W.L. Van Neerven, *IJMP 10 (1995) 2921*
 - S. Gavin et al., *IJMP 10 (1995) 2961*
 - **Direct photon production**
 - J. Cleymans et al., *IJMP 10 (1995) 2941*
 - **Heavy quark production**
 - P.L. McGaughey et al., *IJMP 10 (1995) 2999*
-

HPC Benchmarks II

- Quarkonium production

- R. Gavai et al., *IJMP* 10 (1995) 3043

- Jet production

- K.J. Eskola and X.N. Wang, *IJMP* 10 (1995) 3071

- Note that PDF's have significantly changed since 1995, mostly due to HERA data and the systematic development of NLO and NNLO parametrizations.

- Hard probes in heavy ion collisions at the LHC

- PDF's, shadowing, and pA collisions – *hep-ph/0308248*
 - Jet physics – *hep-ph/0310274*
 - Heavy flavour physics – *hep-ph/0311048*
-

Why am I Giving this Lecture?

- Mutual observation: There is no *canonical introduction* to a “RHIC talk” as opposed to a typical (*insert your favorite facility*) talk.
 - General truism: No one who has a significant history in a field can give an unbiased, meaningful introduction. This is my first *Hard Probes* meeting ...
 - I am a member of the IAC for *Hard Probes 2004*.
 - I bribed Carlos Lourenço.
 - I forgot to bribe Carlos Lourenço.
 - I thought the meeting would be held in *September*.
 - I accepted the invitation without thinking very clearly.
-

The Curse of Bounty

- There's much too much material for a single lecture (or even two or three!)
 - Thus the HPC material needed to be distilled.
 - You all are the judges whether it is "moonshine"
 - Or single malt Scotch whisky...
-

Why Hard Probes?

- Probes generated by hard QCD processes are calculable perturbatively, in a controlled manner.
- Their modification by the hot medium created in heavy ion collisions can be utilized to determine medium properties.

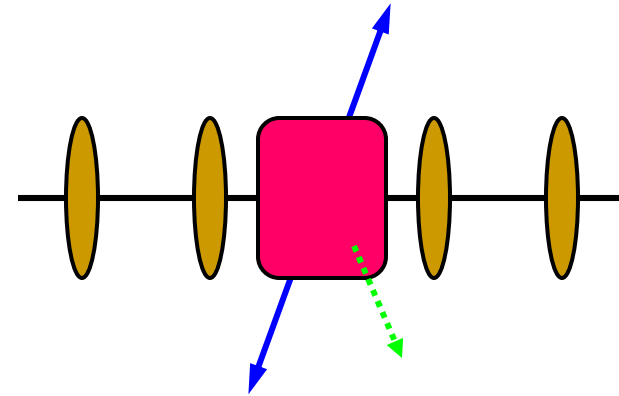

Penetrating (EM) probes emitted by the hot medium itself are also calculable and can be used to measure its state and properties.

What Are Hard Probes?

- The hard processes of interest in HI collisions are:
 - **Prompt photons**
 - **(Drell-Yan) lepton pairs**
 - **Hadrons with open charm or beauty**
 - **Heavy quarkonia (Ψ or Υ)**
 - **Hard jets and hadrons at large p_T**
 - The classic hard probe: deep-inelastic lepton scattering
 - **Theoretically best understood and experimentally most explored hard QCD process – original motivation for QCD**
 - **Source of parton distribution functions**
 - **Test-bed of theoretical concepts and approaches**
-

QCD Factorization

Inclusive cross section $h \rightarrow X$

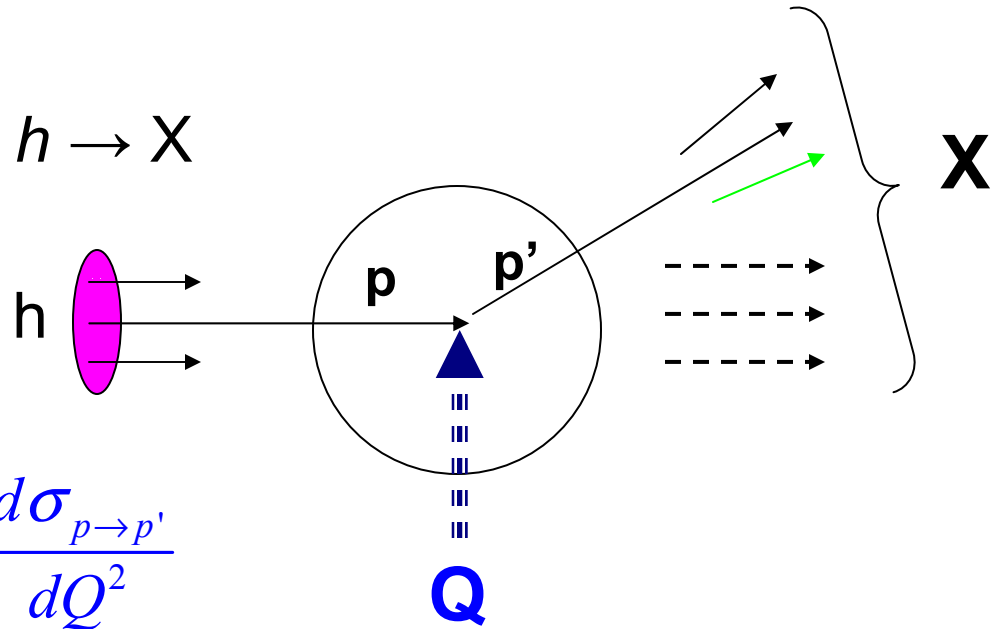

$$\sum_X \frac{d\sigma_{h \rightarrow X}}{dQ^2} = f(h \rightarrow p) \otimes \frac{d\sigma_{p \rightarrow p'}}{dQ^2}$$

Semi-inclusive cross section $h \rightarrow h' + X$

$$\sum_X \frac{d\sigma_{h \rightarrow h' + X}}{dQ^2} = f(h \rightarrow p) \otimes \frac{d\sigma_{p \rightarrow p'}}{dQ^2} \otimes D(p' \rightarrow h')$$

LO-pQCD Cross Sections

$$\frac{d\sigma}{dt} = \frac{\pi\alpha_s^2(Q^2)}{s^2} |M(s,t,u)|^2$$

$$\frac{d\sigma}{dt} = \frac{\pi\alpha\alpha_s(Q^2)}{s^2} |M(s,t,u)|^2$$

g g → g g	$\frac{9}{2} \left(3 - \frac{tu}{s^2} - \frac{su}{t^2} - \frac{st}{u^2} \right)$	q q' → q q'	$\frac{4}{9} \frac{s^2 + u^2}{t^2}$
q g → q g	$-\frac{4}{9} \left(\frac{s}{u} + \frac{u}{s} \right) + \frac{s^2 + u^2}{t^2}$	q qbar → q' qbar'	$\frac{4}{9} \frac{t^2 + u^2}{s^2}$
g g → q qbar	$\frac{1}{6} \left(\frac{t}{u} + \frac{u}{t} \right) - \frac{3}{8} \frac{t^2 + u^2}{s^2}$	q g → q γ	$-\frac{e_q^2}{3} \left(\frac{u}{s} + \frac{s}{u} \right)$
q q → q q	$\frac{4}{9} \left(\frac{s^2 + u^2}{t^2} + \frac{s^2 + t^2}{u^2} \right) - \frac{8}{27} \frac{s^2}{tu}$	q qbar → g γ	$\frac{8}{9} e_q^2 \left(\frac{u}{t} + \frac{t}{u} \right)$
q qbar → q qbar	$\frac{4}{9} \left(\frac{s^2 + u^2}{t^2} + \frac{u^2 + t^2}{s^2} \right) - \frac{8}{27} \frac{u^2}{st}$	q qbar → γ γ	$\frac{2}{3} e_q^4 \left(\frac{u}{t} + \frac{t}{u} \right)$
q qbar → g g	$\frac{32}{27} \left(\frac{t}{u} + \frac{u}{t} \right) - \frac{8}{3} \frac{t^2 + u^2}{s^2}$		

Factorization in pQCD

- Ability to *factorize* scattering cross sections into pQCD calculable parton scattering processes and measured, nonperturbative parton distribution or fragmentation functions is encoded in *factorization theorems*.
 - For $p_h \gg m_h$, $f(h \rightarrow p)$ can only be a function of $x = p/p_h$: *Bjorken scaling*.
 - Similarly, $D(p' \rightarrow h')$ can only depend on $z = p_h'/p'$.
 - In QCD, naïve scaling is modified by *scaling violations* due to higher order corrections, which depend on the *resolution scale* Q^2 .
-

Scale Dependence

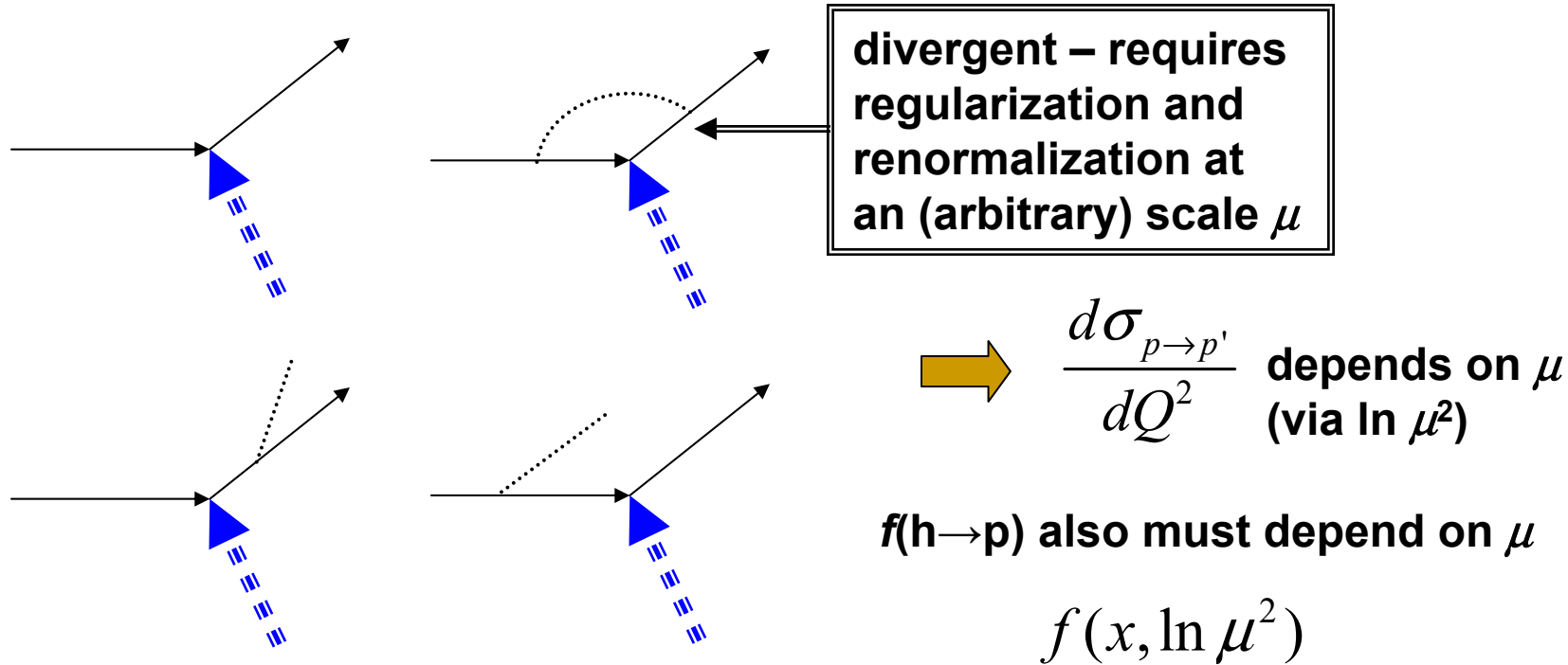

DGLAP eqs:
$$\frac{d}{d \ln \mu^2} f_i(x, \mu^2) = \frac{\alpha_s(\mu^2)}{2\pi} \sum_j \int_x^1 dz P_{ij}(z) f_j(x/z, \mu^2)$$

Higher Order pQCD Effects

- **NLO/NNLO pQCD calculations**
 - Allow definition of relevant scale Q^2 in α_s ;
 - Include radiative effects (splitting) in matrix element, reducing the number of partons in pdf's;
 - Include final state enhancements due to radiation and vertex corrections (\rightarrow *K-factor* in LO calculations);
 - Generate “intrinsic” k_T of partons by initial state radiation;

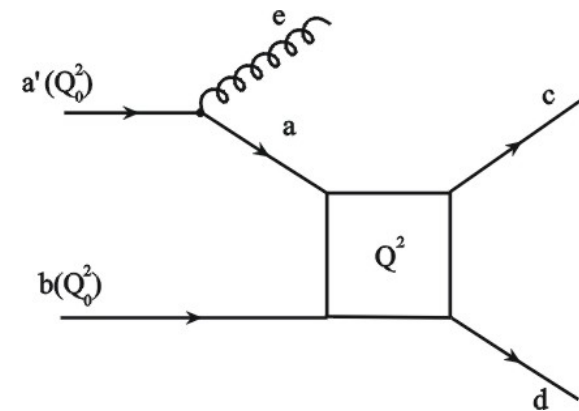
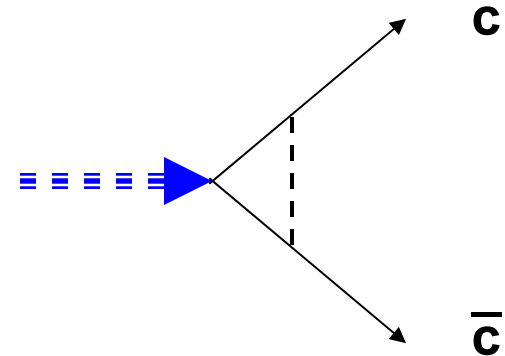

Structure Functions and PDFs

- Deep-inelastic scattering (DIS) by e, μ, ν measure **structure functions** $F(x, Q^2)$, which are related to **parton distribution functions** (PDFs) $f_i(x, Q^2)$.

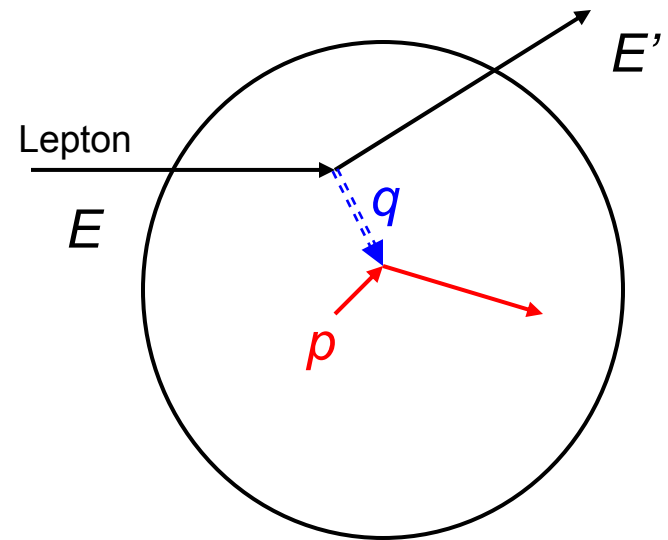

$$\frac{1}{x} F_2^{ep} = \frac{4}{9} (u + \bar{u}) + \frac{1}{9} (d + \bar{d} + s + \bar{s}) + \dots$$

$$\frac{1}{x} F_2^{en} = \frac{4}{9} (d + \bar{d}) + \frac{1}{9} (u + \bar{u} + s + \bar{s}) + \dots$$

$$Q^2 = -q^2, \quad x = \frac{-q^2}{2p \cdot q} = \frac{Q^2}{2M(E - E')}$$

$$\frac{d\sigma}{d\Omega} = \left(\frac{d\sigma}{d\Omega} \right)_{\text{Mott}} \frac{E}{E'} \left[\left(F_1(x)^2 + \frac{\kappa Q^2}{4M^2} F_2(x)^2 \right) + \frac{Q^2}{2M^2} (F_1(x) + \kappa F_2(x))^2 \tan^2 \frac{\theta}{2} \right]$$

Sum Rules

Valence quark counting rules (Gross-Llewellyn Smith):

$$\int_0^1 dx [u(x) - \bar{u}(x)] = 2; \quad \int_0^1 dx [d(x) - \bar{d}(x)] = 1; \quad \int_0^1 dx [s(x) - \bar{s}(x)] = 0$$

Momentum sum rule:
$$\int_0^1 x dx \left[\sum_f (q_f(x) + \bar{q}_f(x)) + G(x) \right] = 1$$

Gottfried sum rule:
$$\int_0^1 dx (u(x) + \bar{u}(x) - d(x) - \bar{d}(x)) \approx 1$$

Only true if $\bar{u}(x) = \bar{d}(x)$

Bjorken sum rule:
$$\int_0^1 dx \left[(u^\uparrow(x) - u^\downarrow(x)) - (d^\uparrow(x) - d^\downarrow(x)) \right] \approx \frac{g_A}{g_V} = 1.25\dots$$

Twist Expansion

Structure functions are defined as [$Q^2 = -q^2$, $x = -q^2/2(p \ll q)$]

$$F_i(x, Q^2) = -\frac{1}{2\pi} \text{Im} \int d^4z e^{-iq \cdot z} \langle N, p | T \hat{J}_i(z) \hat{J}_i(0) | N, p \rangle$$

The product of operators is expanded in a power series:

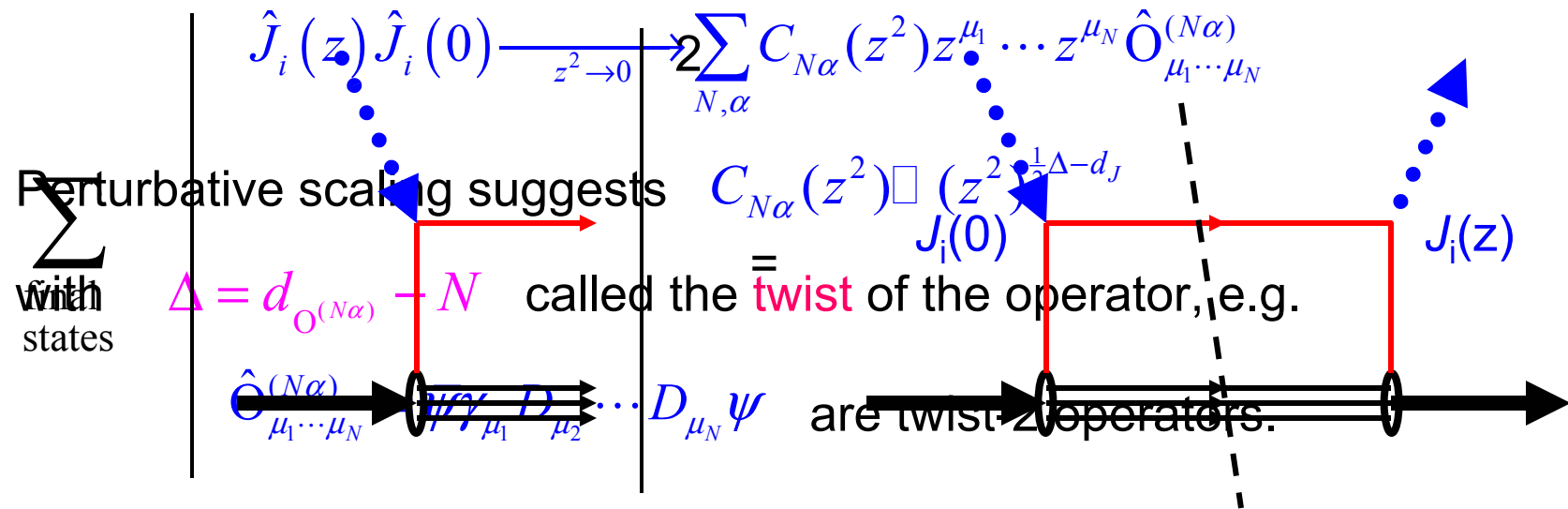

Higher-twist contributions are suppressed by factors $(1/Q^2)^{\Delta-2}$.

Higher Twist Effects

- Higher twist corresponds to parton interactions beyond a hard scattering vertex, i.e. initial- and final-state interactions, which cannot be described as nuclear modifications of the pdf's.
- H.T. processes can also be factorized like L.T., but with new higher-twist pdf's.
- H.T effects can be large in processes, which are small at the L.T. level, e.g. DY pairs with $p_T \sim M_{\text{had}}$.

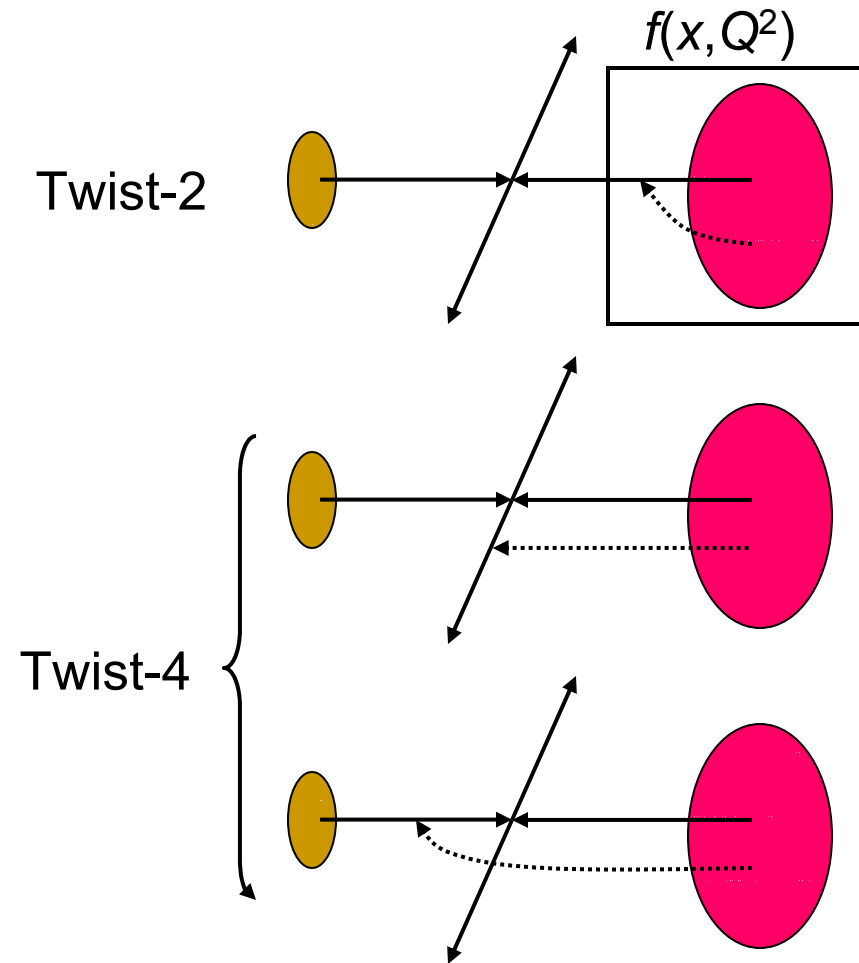

Parton Distribution Functions

- From fits to experimental data, mostly electron and neutrino DIS, and Drell-Yan.
- Latest versions as codes from CTEQ, MRST, Alekhin.
- Different parametrizations for LO, NLO, NNLO cross section calculations.
- Conveniently accessible from Durham web site:
 - <http://durpdg.dur.ac.uk/HEPDATA/PDF> with nice graphical interface.

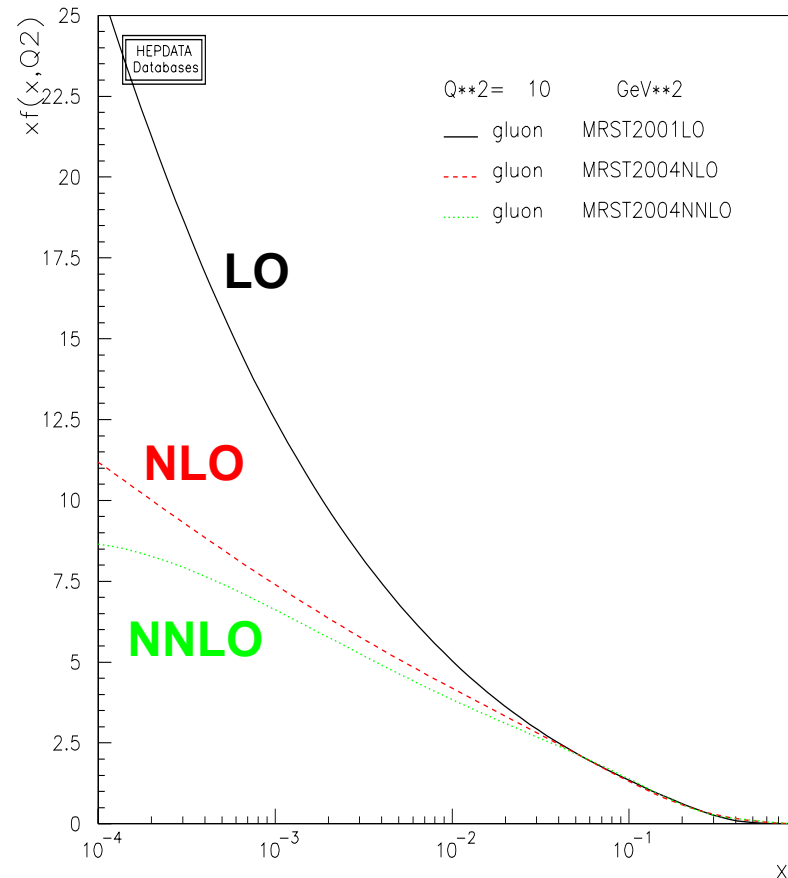

Some PDF Samples

Quark flavors u, u-bar, s, c

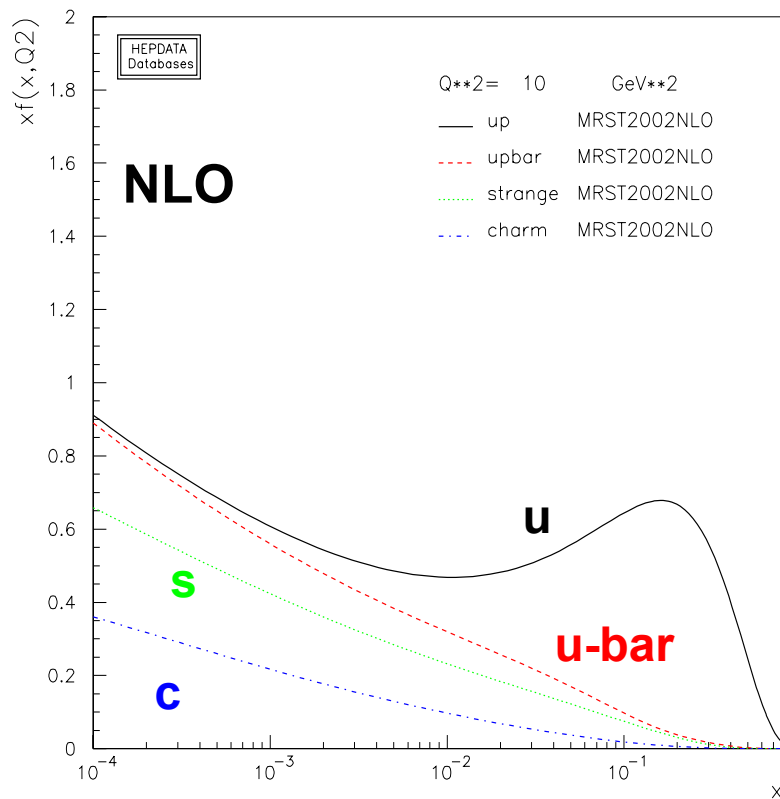

Quarks vs. gluons

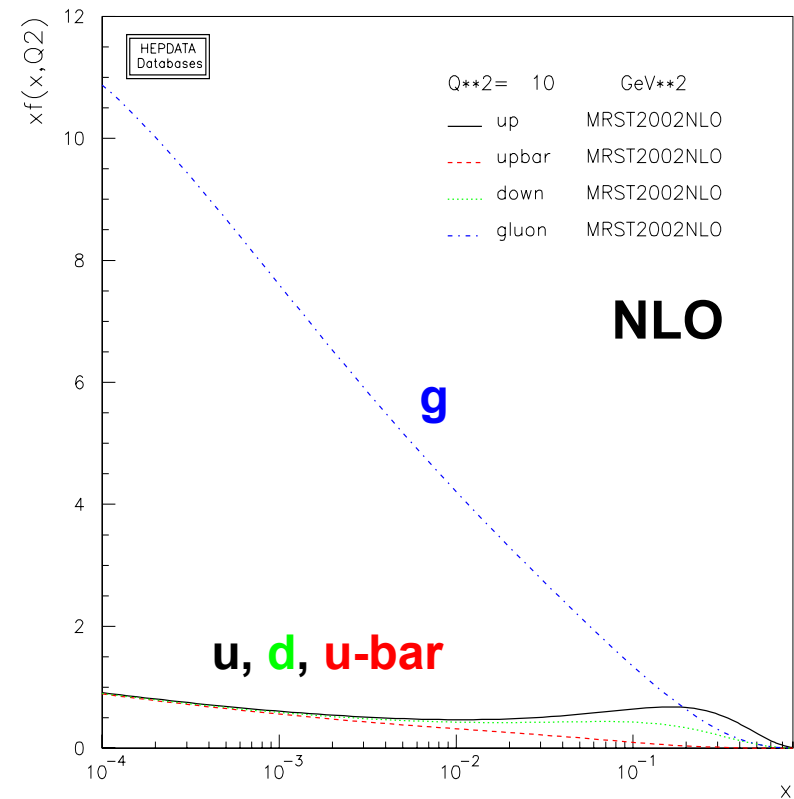

PDF Uncertainties

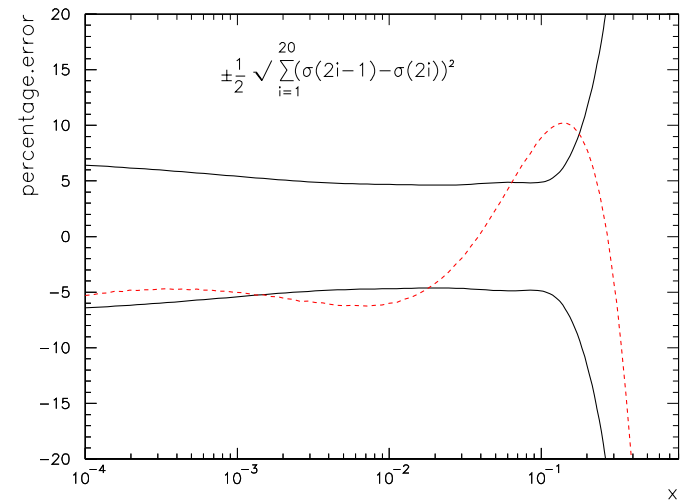
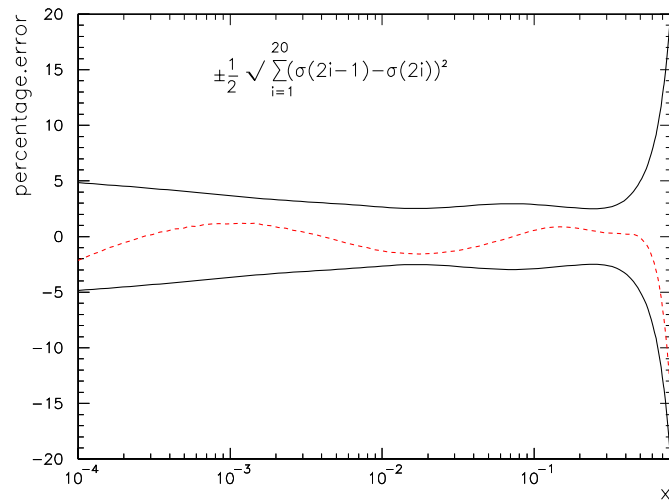
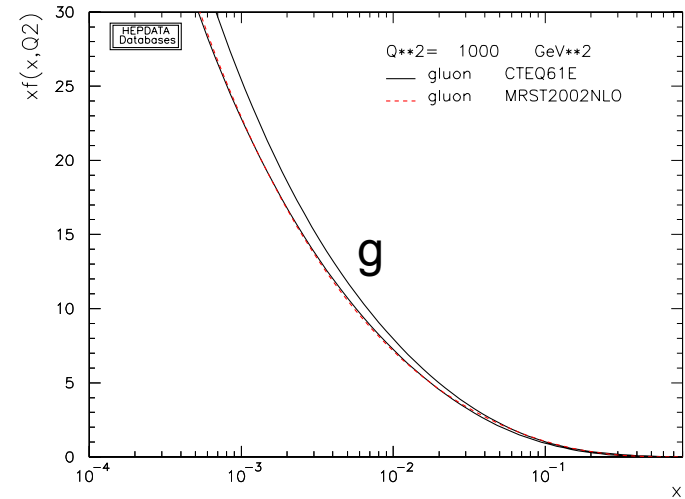
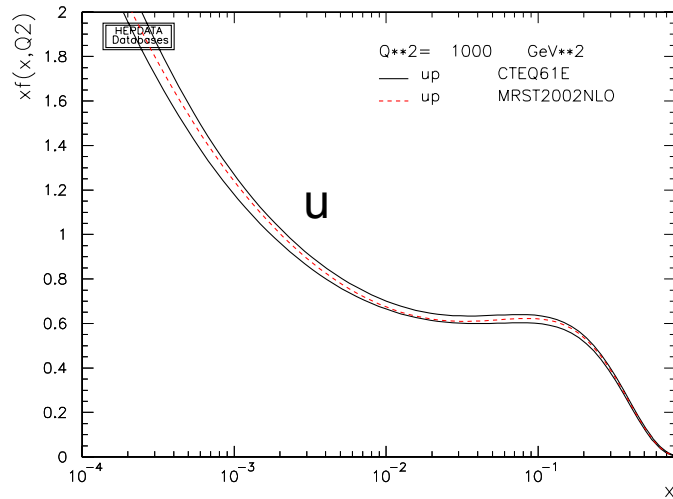

k_T Factorization

- Standard “collinear” QCD factorization, combined with DGLAP evolution allows to resum contributions $\sim [\alpha_s \ln(Q^2/\Lambda^2)]^n$.
- At small x and moderately large Q^2 , it may be more important to resum contributions $\sim [\alpha_s \ln(1/x)]^n$. This is achieved by the k_T factorization scheme with LO amplitudes.
- Especially useful to describe gluon saturation effects (CGC).
- Presently not known how to generalize to NLO calculations.

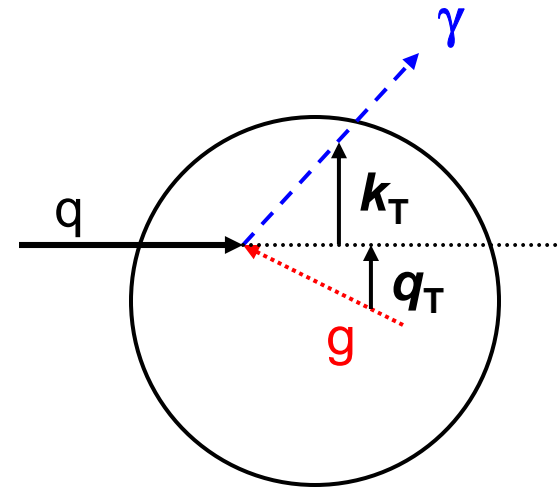

$$\frac{d\sigma}{d^2k_T} = \int \frac{dq_T^2}{q_T^2} \Phi_G(q_T^2, x) |A_{LO}(q_T, k_T)|^2$$

Quarkonium Production

- Color “evaporation” model:

- Assumes that heavy quark pair is produced in any spin & color state, s/c quantum numbers are “evaporated” by exchange of soft gluons with surrounding color field.

$$\sigma_{(Q\bar{Q})}^{\text{CEM}} = F_C \sum_{ij} \int_{4m_Q^2}^{4m_H^2} d\hat{s} \int dx_1 dx_2 f_{i|A}(x_1, \mu^2) f_{j|B}(x_2, \mu^2) \sigma_{ij}(\hat{s} - x_1 x_2 s)$$

- Typical fit values F_Ψ and F_Υ lie in range 0.01 – 0.02.

- NRQCD approach:

- Factorizes quarkonium production into pQCD production in a specific s/c channel and a nonperturbative matrix element for the $(QQ)_{s/c}$ component in the quarkonium wave function.
-

NRQCD Formalism

$$\sigma_H = \sum_{c/s} \sum_{ij} \int dx_1 dx_2 \int dx_1 dx_2 f_{i|A}(x_1, \mu^2) f_{j|B}(x_2, \mu^2) \sigma_{ij}^{(Q\bar{Q})_{c/s}} \langle \mathcal{O}_{c/s}^H \rangle$$

Significant color/spin channels:

C	S
1	3S_1
1	3P_J
8	1S_0
8	3S_1
8	3P_J

At large p_T , NLO contribution from gluon fragmentation is expected to dominate:

$$\sigma_{ij}^{(QQ)} \Big|_8^{^3S_1} = \sigma_{ij}^g D_g^{(QQ)} \Big|_8^{^3S_1}$$

Tests of NRQCD Approach

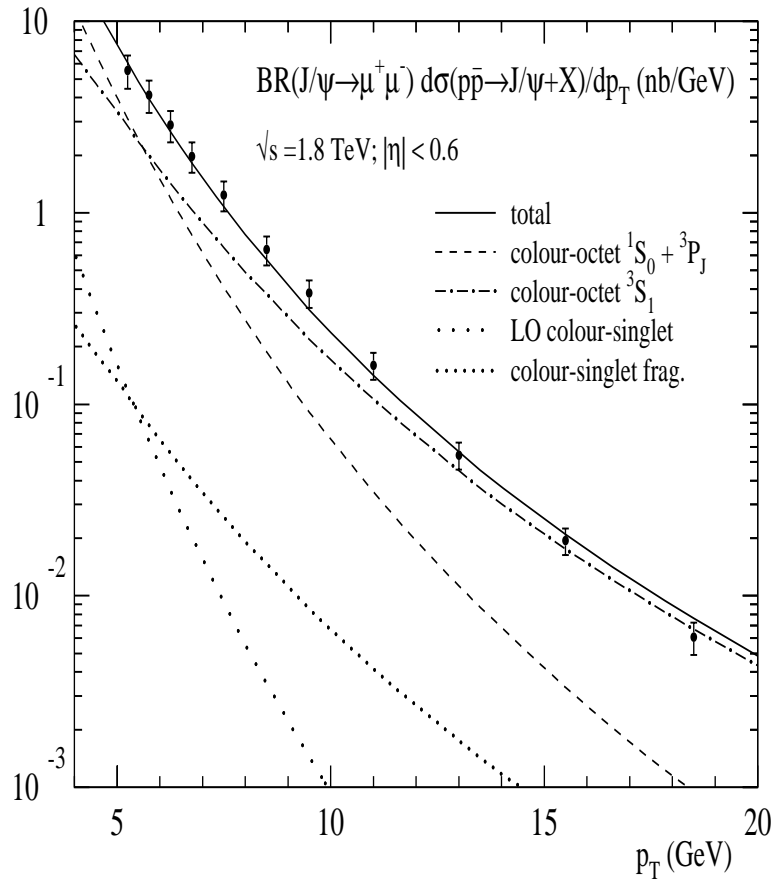

Gluon fragmentation should lead to J/Ψ polarization at high p_T

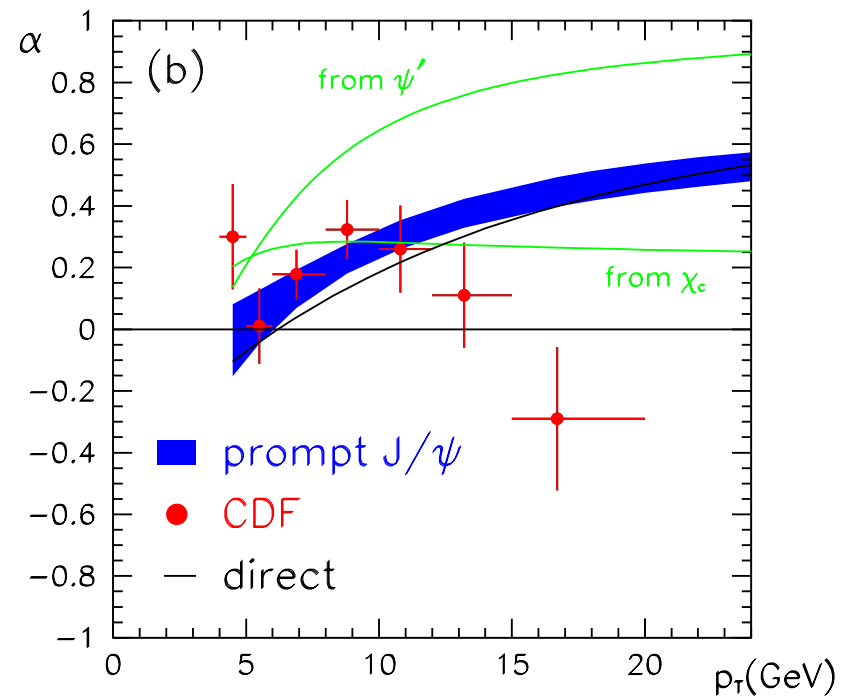

From pp to pA

- Hard processes are, in first approximation, additive in the number of target nucleons:
 - $\sigma_{pA} = A \sigma_{pN}$
- Multiple scattering effects generate corrections:
 - **Shadowing**
 - **Saturation**
 - **p_T broadening**
 - **Energy loss**
- If dependent on A and parton species, not QCD process: nuclear modification of pdf's.

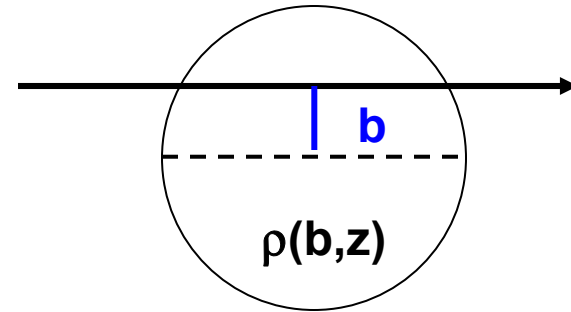

$$\frac{d\sigma_{pA}}{d^2b} = \sigma_{pN} \int dz \rho(b, z) \equiv \sigma_{pN} T_A(b)$$

$$\text{with } \int d^2b T_A(b) = A$$

Note: Higher-twist effects grow like $A^{1/3}/Q^2$, can be resummed in certain cases.

Nuclear Shadowing

- Double scattering with forward scattered intermediate inelastic (diffractive) states results in negative contribution to the hard scattering amplitude:

$$\frac{\sigma_2(M)}{\sigma_1} \approx -(A-1)T_A(b) \left. \frac{d\sigma_D}{dM^2} \right|_{t=0}$$

- Shadowing increases with decreasing x and Q_2 .

$$R_i^A(x, Q^2) = f_{i|A}(x, Q^2) / Af_{i|N}(x, Q^2)$$

- Parametrizations (EKS, HKM).
At very small x - saturation of the gluon distribution.

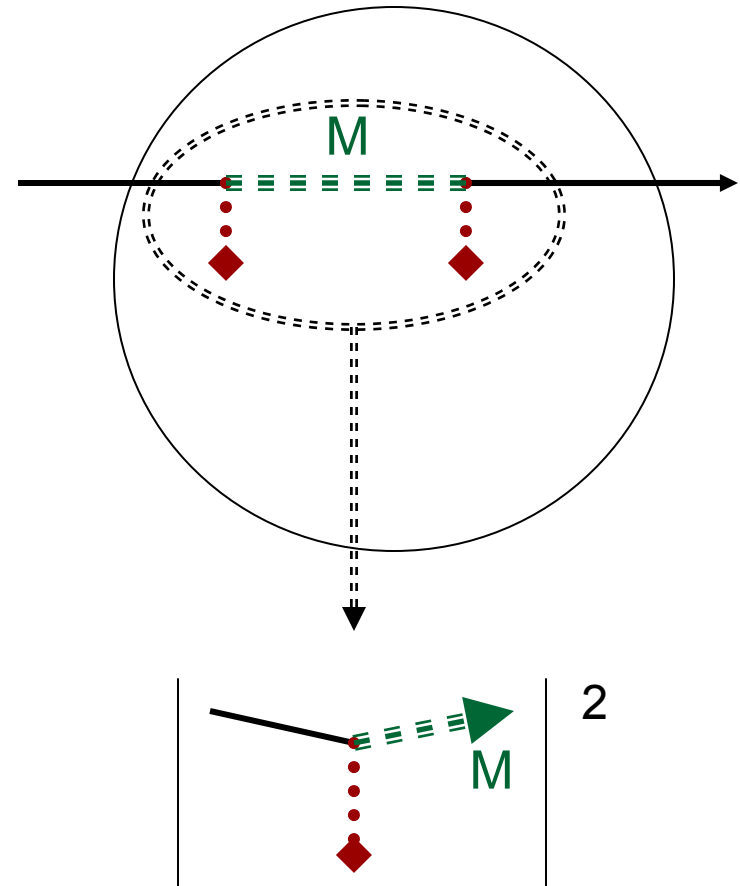

Nuclear PDF's - Data

Present data cover a narrow x - Q^2 range, large parts of RHIC & LHC regions remain uncovered.

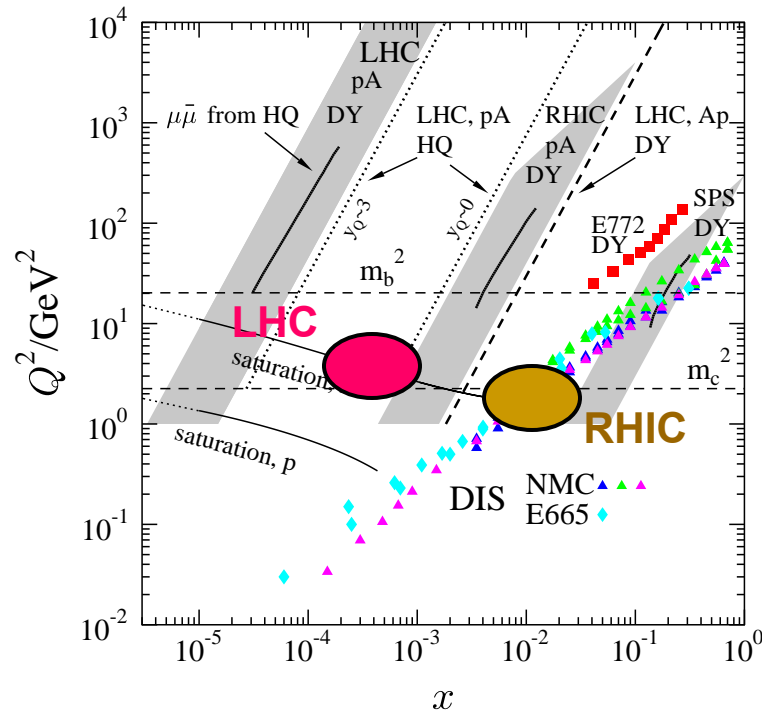

EKS = Eskola, Kolhinen, Salgado

HKM = Hirai, Kumano, Miyama (not using NMC and DY data!)

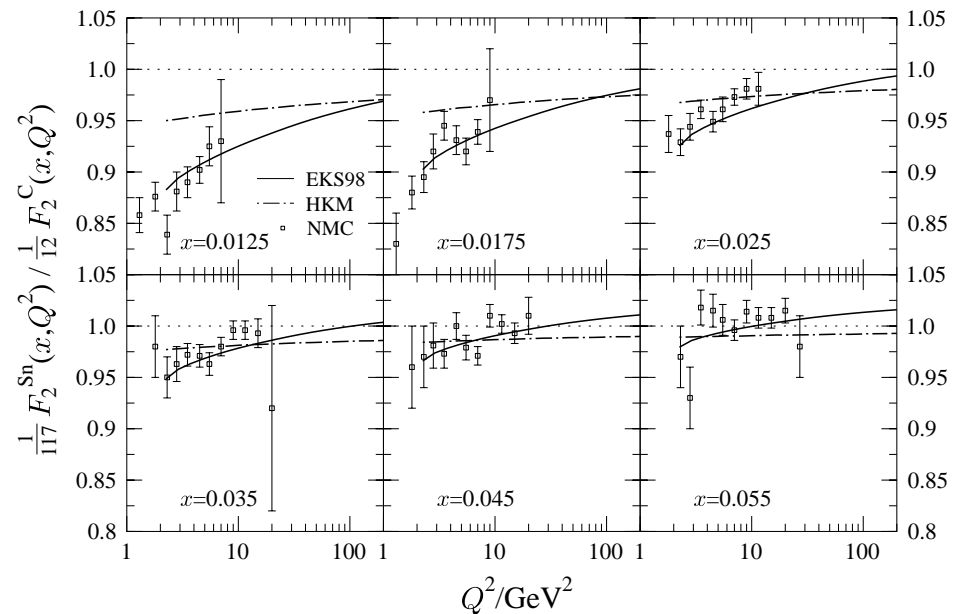

Parton Saturation

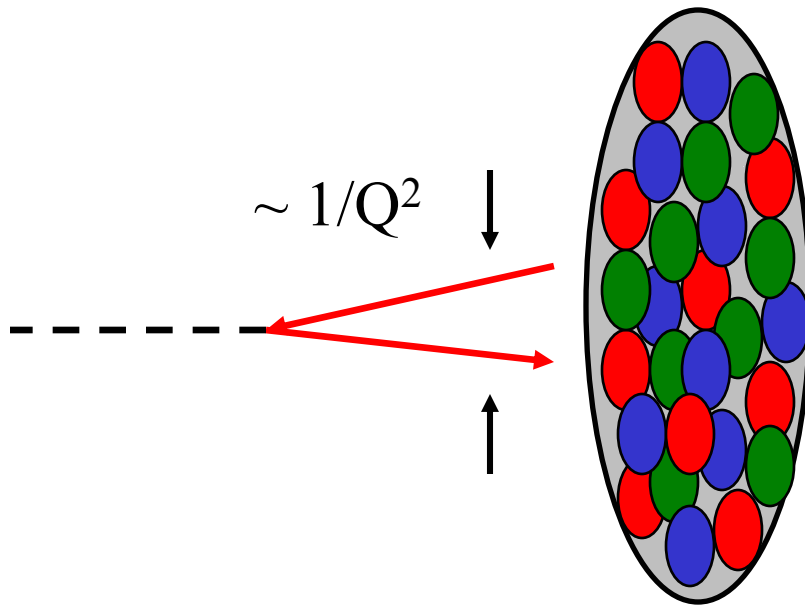

“color glass condensate”

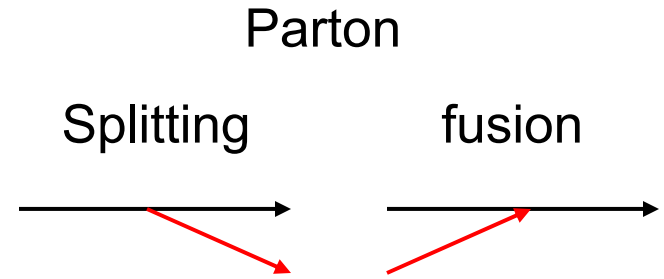

$$\frac{dxG(x, Q^2)}{d \ln Q^2} = \left[\frac{dxG(x, Q^2)}{d \ln Q^2} \right]_{\text{DGLAP}} - \frac{9\pi\alpha_s^2}{2Q^2 \pi R_A^2} \int_x^1 \frac{dy}{y} [yG(y, Q^2)]^2$$

$$\Rightarrow Q_{\text{sat}}^2(x, A)$$

$$\text{parton density} \times \text{area} = \frac{xG_A(x, Q^2)}{\pi R_A^2} \times \frac{\alpha_s}{Q^2} \square \frac{A^{1/3} x^{-\lambda}}{Q^2} \square 1$$

p_T Broadening

- Elastic scattering of incoming or outgoing partons on nuclear gluons leads to broadening of parton p_T distribution.
- Multiple scattering can be described as random walk in p_T .
- Description is gauge dependent:
 p_T broadening of produced gluons = nuclear modification of gluon pdf due to gluon fusion = onset of saturation

*Yu.V. Kovchegov and A.H. Mueller,
Nucl.Phys. B529 (1998) 451*

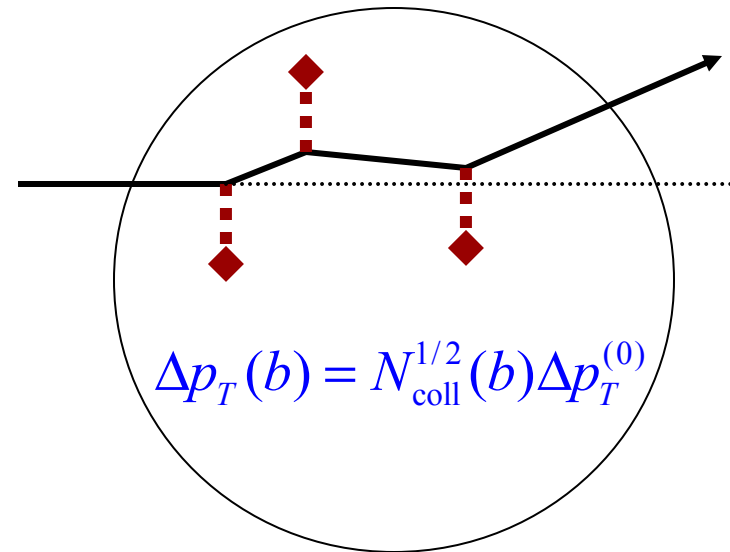

$$(\Delta p_T)^2 = (\Delta p_T)_{\text{intrinsic}}^2 + (\Delta p_T)_{\text{coll}}^2$$

$$\text{with } (\Delta p_T)_{\text{coll}}^2 \sim A^{1/3}$$

Parton Energy Loss

- In QCD dominated by gluon radiation: multiply scattering parton is off the mass shell, accumulates phase shift $\Delta\phi$

$$\omega^2 - k^2 \approx (\omega - k)2\omega = k_T^2$$

- $\Delta\phi > 1$ requires $\omega < \omega_c$
- *LPM effect* in QCD: $dE/dx \sim L$
- Cold nuclear matter from DIS and DY data:

$$\hat{q} = 0.4 - 0.7 \text{ GeV/fm}^2$$

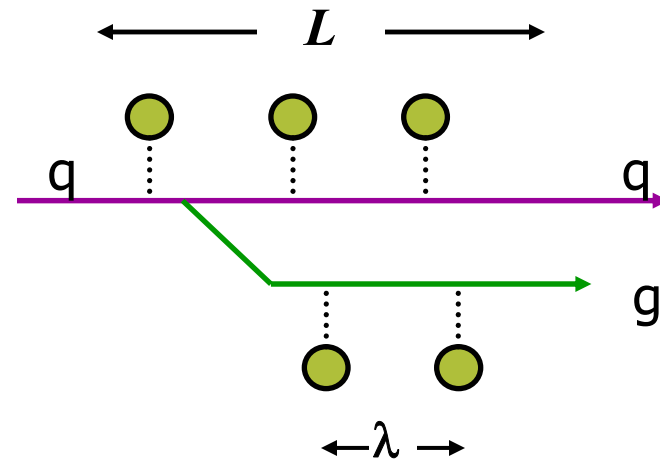

$$\exp(i\omega t - ikz) = \exp(i\phi)$$

$$\Delta\phi = (\omega - k) \Delta z = \frac{k_T^2}{2\omega} \Delta z$$

$$= \frac{\mu^2 L}{2\omega\lambda} L = \frac{\hat{q} L^2}{2\omega} \equiv \frac{\omega_c}{\omega}$$

In-Medium Fragmentation

- Collisionally induced radiation from a hard parton in medium can be treated like a higher twist effect, resulting in an in-medium modified fragmentation function:

$$\tilde{D}_{p \rightarrow h}(z_h, \mu^2) = D_{q \rightarrow h}(z_h, \mu^2) + \frac{\alpha_s}{2\pi} \int_0^{\mu^2} \frac{d\ell_T^2}{\ell_T^2} \int_{z_h}^1 \frac{dz}{z} \left[\begin{aligned} &\Delta\gamma_{p \rightarrow pg}(z, \ell_T^2) D_{p \rightarrow h}\left(\frac{z_h}{z}, \ell_T^2\right) \\ &+ \Delta\gamma_{p \rightarrow gp}(z, \ell_T^2) D_{g \rightarrow h}\left(\frac{z_h}{z}, \ell_T^2\right) \end{aligned} \right]$$

where $\Delta\gamma_{p \rightarrow pg}(z, x, x', \ell_T^2)$ is a generalized splitting function, which involves a twist-4 parton distribution. Correction term is of order $\alpha_s(R_A/\mu)^2$. Can be written as effective energy loss ΔE :

$$\tilde{D}_{p \rightarrow h}(z_h, \mu^2) \approx D_{p \rightarrow h}(z_h + \Delta z, \mu^2) = D_{p \rightarrow h}\left(\frac{z_h}{1 - \Delta E/E}, \mu^2\right)$$

pA Benchmark Tests

- Drell-Yan (e^+e^-) pairs, W- and Z-production
 - (e^+e^-), W and Z transverse momentum spectrum
 - Jet and dijet rates, high- p_T hadrons
 - Dijet E_T balance, coplanarity
 - Quarkonium p_T spectra
 - Direct photons
-

Hard Probes in A+A: Jet Quenching

- Hard scattered partons lose energy on passage through comoving hot matter. Clearly observed in Au+Au, not p+Au.
- Leading hadrons come mostly from the near-side surface, and away-side hadrons are strongly suppressed.
- Effective energy loss parameter

$$\hat{q}L^2 \Rightarrow (\hat{q}L^2)_{\text{eff}} = \frac{2\hat{q}_0}{\rho(r)} \int \tau d\tau \rho(r_\tau, \tau)$$

with $\langle \hat{q} \rangle \approx 50 \text{ GeV}/\text{fm}^2$

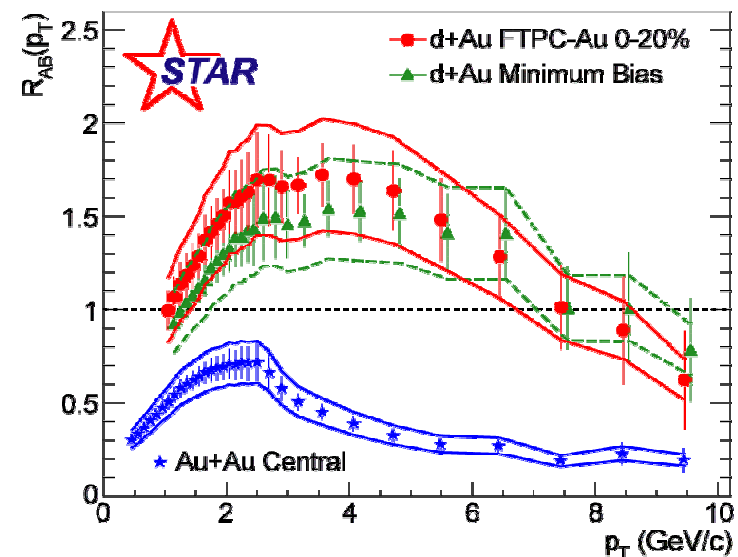
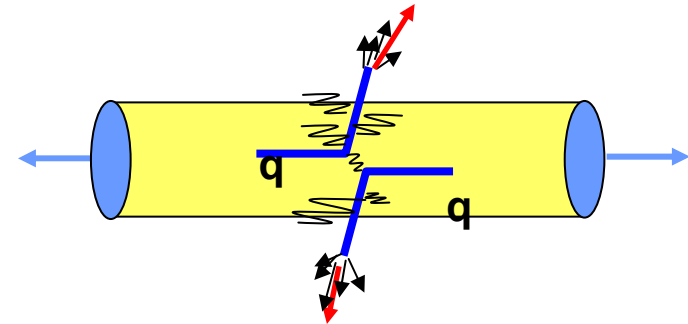

What Does Jet Quenching Probe?

- pQCD predicts energy loss as function of energy density and α_s :
 $dE/dx \sim [\alpha_s(\mu^2)]^3$.
 But what is the relevant value of α_s ?
 Full NLO calculation would help!
- Present formalism allows for $\Delta E > E$.
 Reweighting procedure is a “poor man’s solution”.
- Is a full description of jet quenching as a medium modification of $D(z)$ including recombination possible?
- If we know ε from ΔE , and the bound on the entropy density from dN/dy , can we set a bound on the degrees of freedom?

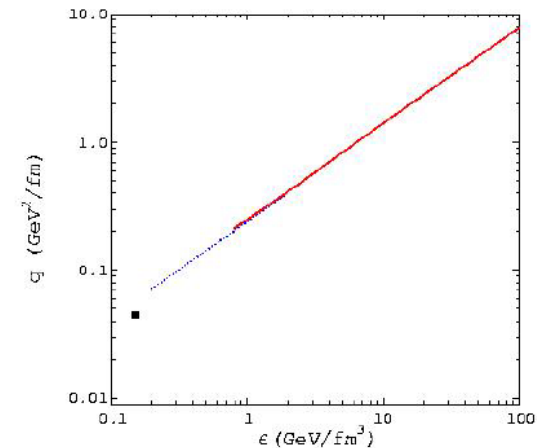
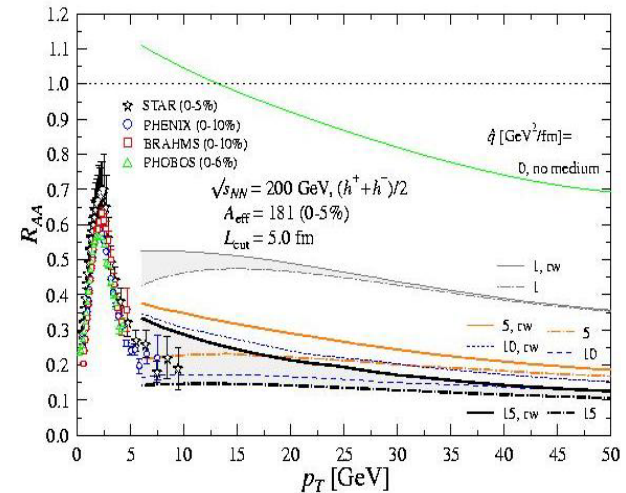

From Hadrons to Jets

- LHC will make jet observables accessible.
- Energy loss of leading parton → modification of the $D(z)$ and energy redistribution within the jet cone
- Difference between light quark and gluon induced jets and jets produced by c, b quarks.
- Non-global jet observables ($E_{\text{out}} < E_c$):

Banfi,
Marchesini, Smye

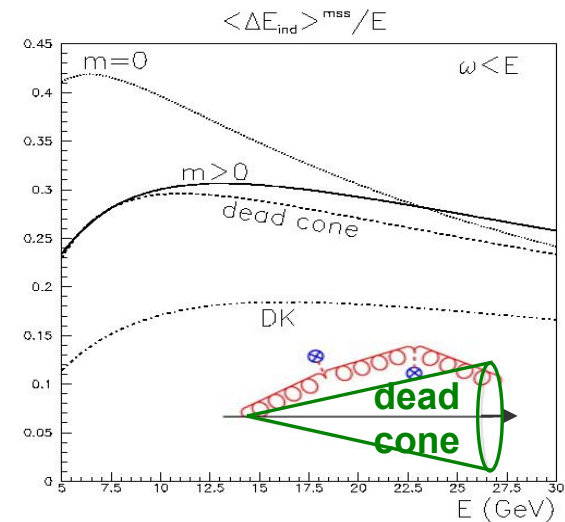
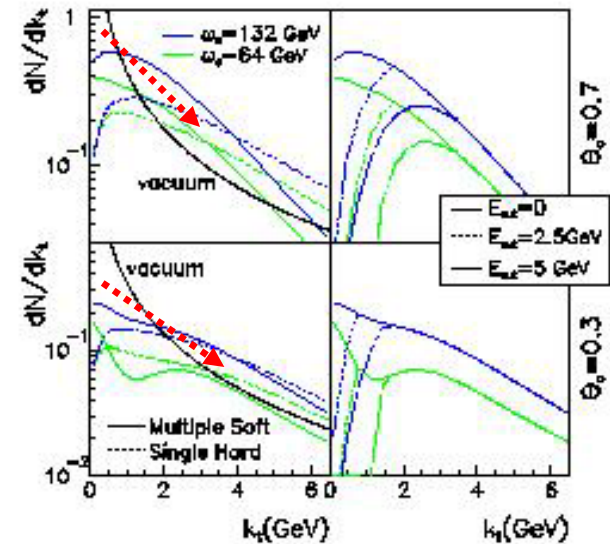
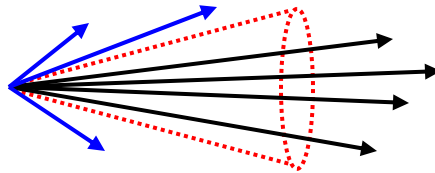

Charmonium Suppression

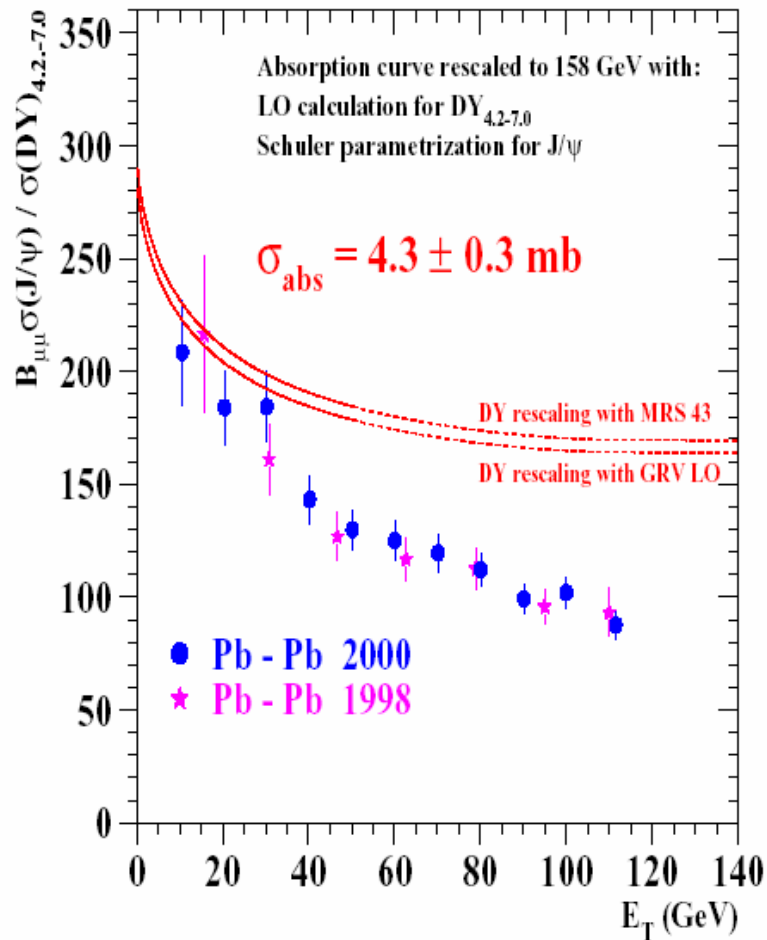

What are the comovers and how do they disrupt J/ψ production ?

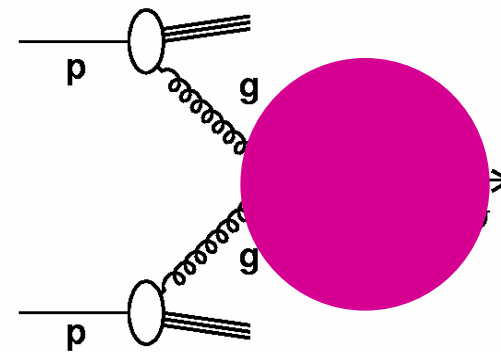

- Absorption by hadrons
- Momentum broadening
- Color screening
- Ionization by (thermal) gluons

Color screening

V_{qq} is screened at scale $(gT)^{-1}$
 \rightarrow heavy quark bound states
 dissolve above *some* T_d .

Quenched LQCD simulations,
 with analytic continuation to
 real time, suggest $T_d \geq 2T_c$!

Color singlet free energy

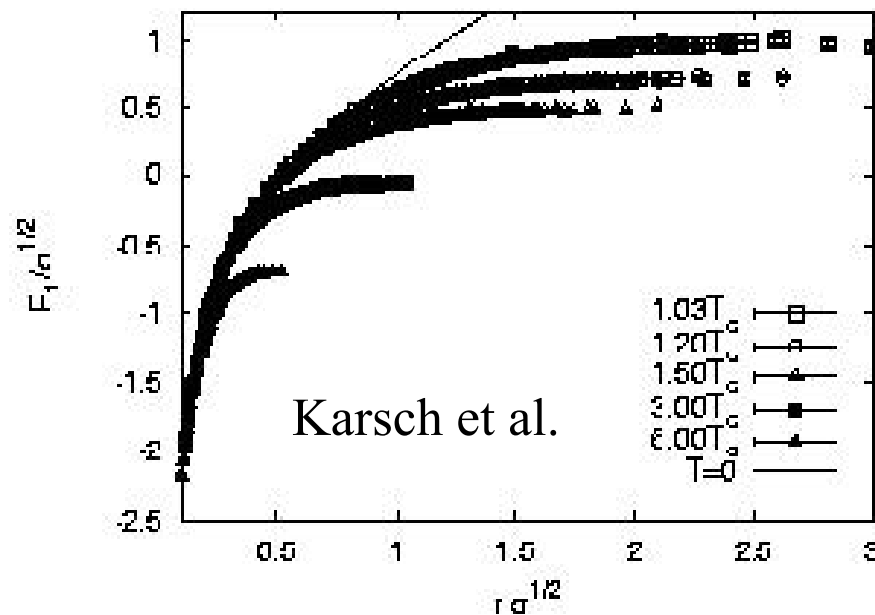

S. Datta et al. (PRD 69, 094507)

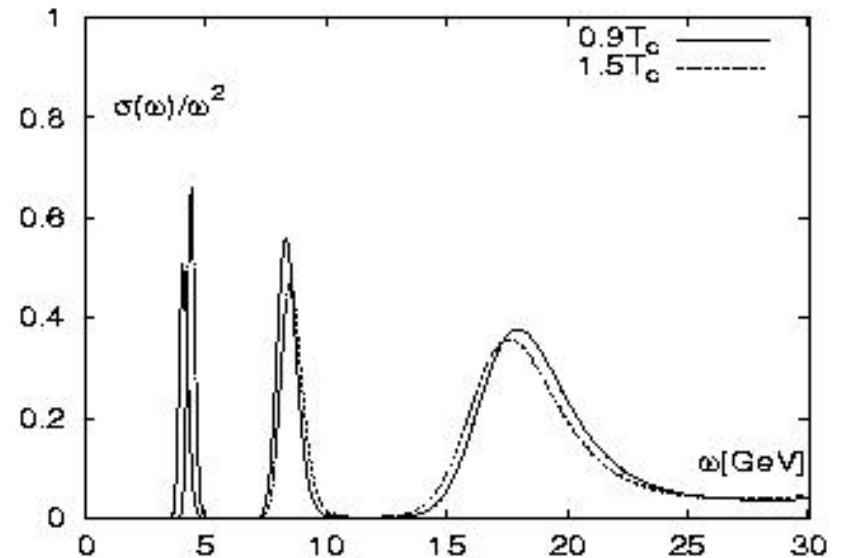

Quarkonium Chemistry

- Ionization of bound J/Ψ and Υ in plasma by thermal gluons:

HPC collab. hep-ph/0311048

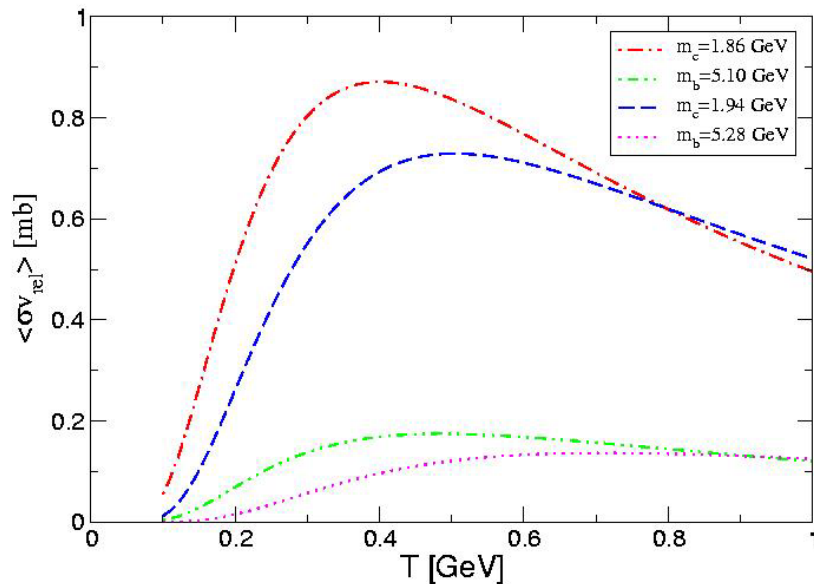

Deconfined c -quarks and c -antiquarks can recombine and form new J/Ψ at hadronization:

Thews, hep-ph/0302050

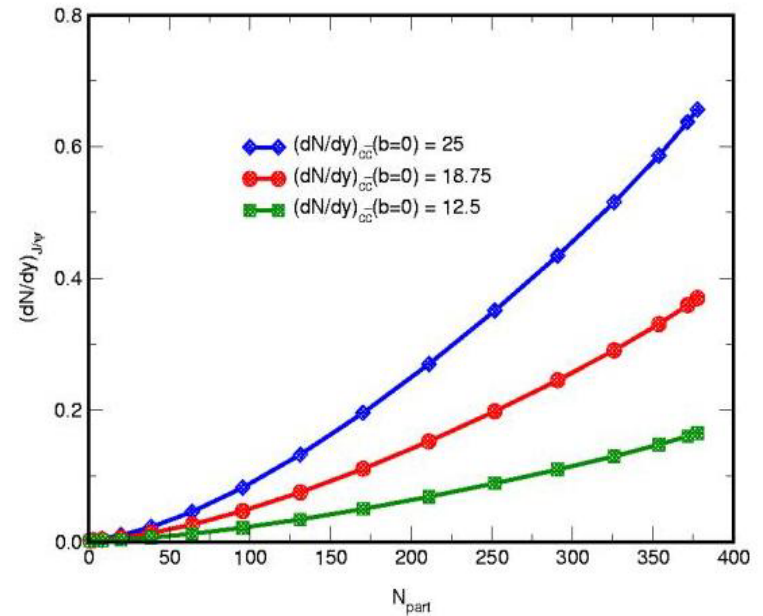

Hard Probes in $A+A$: Heavy Quarks

- **Heavy quarkonium yield as “thermometer” for the QGP:**
 - Can one distinguish disappearance due to color screening from destruction by gluon absorption or scattering?
 - Can HQET be used to develop a theory of quarkonium formation and propagation in matter, similar to energy loss theory?
 - Can heavy quark recombination be calculated reliably?
 - **Heavy quark energy loss:**
 - Is open charm / beauty production influenced by environment?
 - Can one derive a systematic transport theory for heavy quarks within hydrodynamically evolving quark-gluon matter?
-

Hard Probes in A+A: Photons

- Hard photons as jet tags
- Thermal photons from the QGP (and hadron gas)
- Direct photons radiated by hard partons in matter

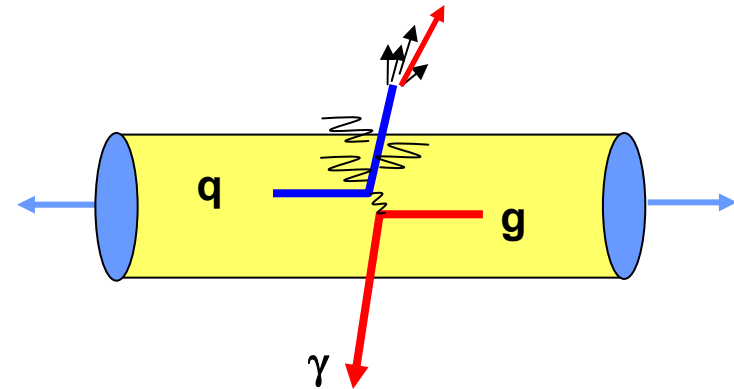

$$\begin{array}{l}
 q + g \rightarrow q + \gamma \\
 q + \bar{q} \rightarrow g + \gamma
 \end{array}
 \rightarrow
 \frac{d\sigma}{dt} = \frac{\pi\alpha_s\alpha_e^2}{s^2} \left(\frac{u}{s} + \frac{s}{u} \right)$$

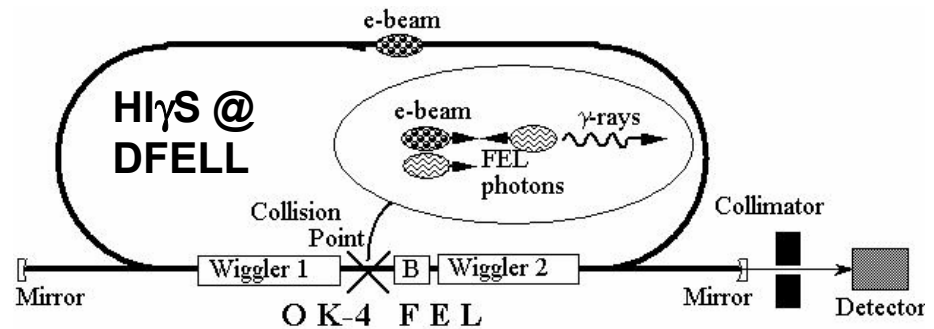
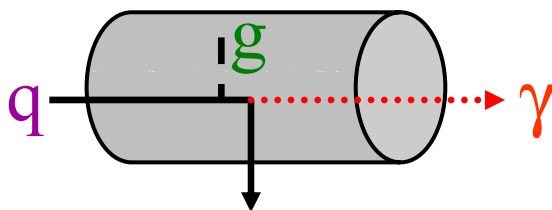

Hard Probes in A+A: Lepton Pairs

- DY pairs as normalization for J/Ψ and Υ .
 - Any nuclear modifications need to be well understood, but none was seen in yield at the SPS.
 - High- p_T , low-mass pairs as surrogate for photons.
 - Especially of interest in fixed target experiments.
 - Thermal dileptons from the QGP and probes of hadron in-medium modifications.
 - Do we really learn about chiral symmetry restoration?
 - DY pairs with $p_T \approx M_{\mu\mu}$ as probes of higher-twist effects.
 - Ideally done in pA collisions.
-

Outlook

- The era of hard probes in heavy ion collisions has just begun: RHIC, LHC, RHIC-II will let hard probes blossom.
 - HPC documents serve as important foundation, but much work needs to be done:
 - Complete LO, LT calculations of medium effects
 - NLO calculations for selected probes, especially jet quenching
 - What exactly do the hard probes tell us about the properties of the medium?
 - Can the medium effects on hard probes be encoded in well defined quantities or matrix elements?
 - Which hard probes probe, e.g., deconfinement?
-