

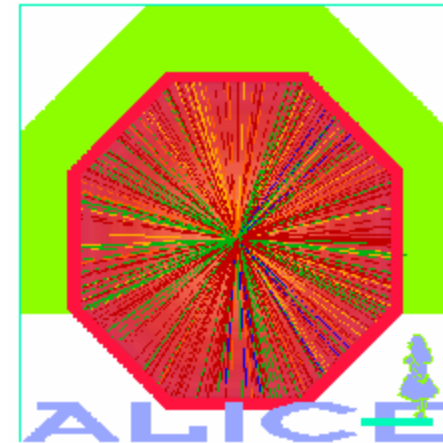

TS workshop  
4 May 2004

## The ALICE Dipole Magnet

- Introduction
- Purpose of the pre-assembly
- Assembly procedure
- Conclusions



A Large Ion Collider Experiment



TS workshop  
4 May 2004

# ALICE Collaboration

- ◆ **Heavy Ion Experiment at LHC**
- ◆ **~ 1000 people**
- ◆ **~ 80 Institutes**
- ◆ **30 countries**

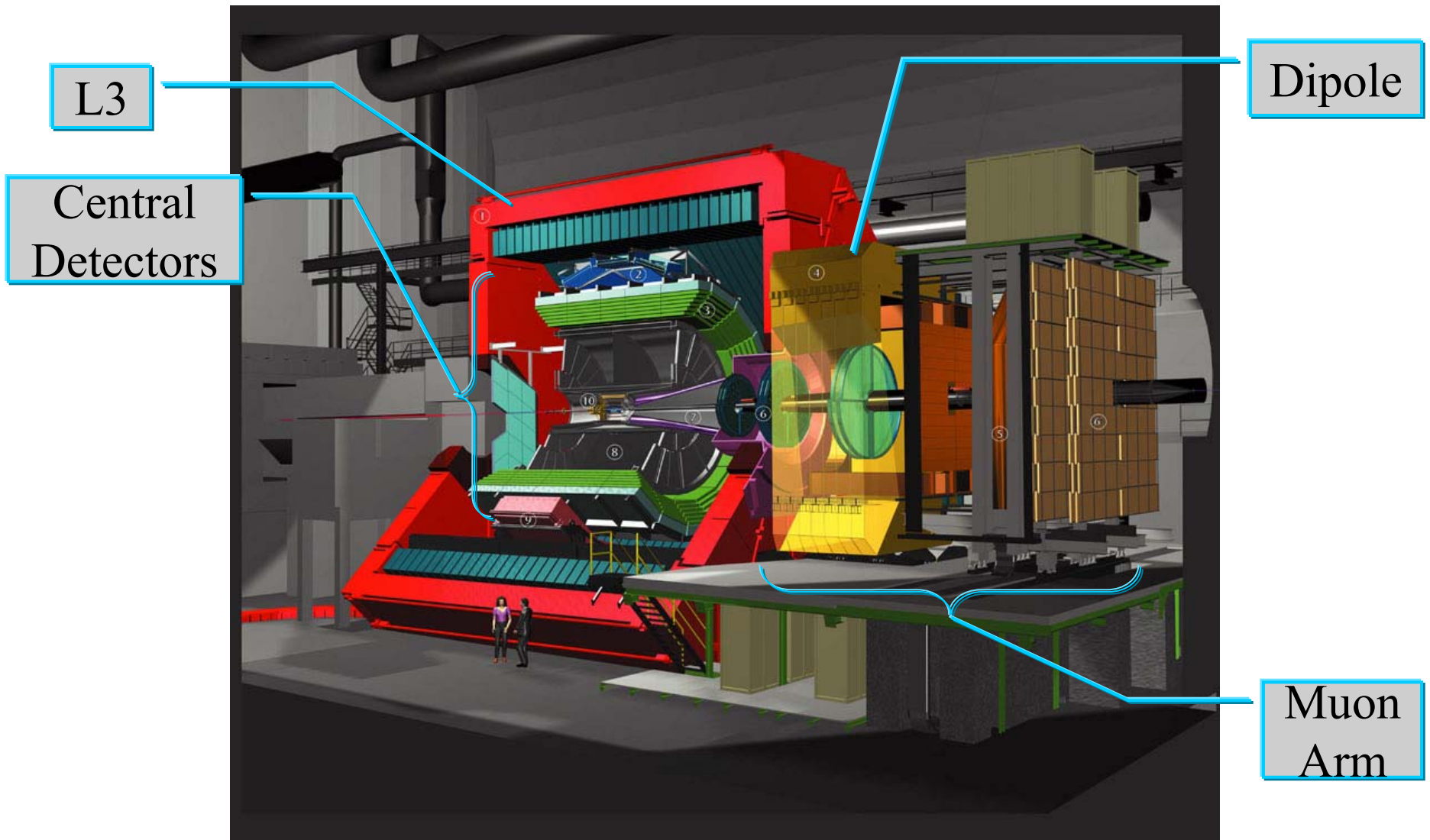

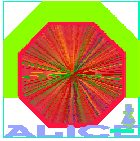

TS workshop  
4 May 2004

## ALICE Dipole Magnet Main Parameters

Parameter	Value	Unit
Max Flux density	0.67	T
Bending Strength	3.00	Tm
Avg. Gap width	3.30	m
Ampere turns	1.97	MA
Operating Current	5.86	kA
Coil Voltage	590	V
Power	3.46	MW
Inductance	1.00	H
Stored energy	17	MJ
Diff. Pressure	10.9	Bar
Diff. Temperature	30	°C
Total weight	880	Tons
Overall Dimensions (H x W x L)	9.0 x 6.7 x 5.0	m x m x m



TS workshop  
4 May 2004

# Dipole Magnet Assembly

## Coils:

- 2 Mirror sym. Al-conductor Saddle coils
- 12 layers/14 turns per coil
- France

## Yoke:

- 28 Laminated Steel Modules
- ~ 30 ton/Module
- Russia



D. Swoboda CERN, Geneva



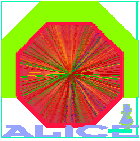

TS workshop  
4 May 2004

# Yoke shipment







TS workshop  
4 May 2004

## Rolling in





TS workshop  
4 May 2004

## Assembly status

Yoke Pre-Assembly in UX25	Started in Nov. 2003
Yoke Pre-Assembly in UX25	terminated 19 Feb. 2004
Coils	Consolidated , surveyed at CERN Apr. 2004
Coil Supports	Partially mounted in yoke Apr. 2004



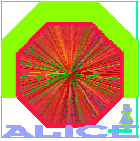

TS workshop  
4 May 2004

## Coil winding



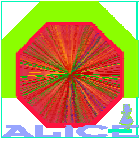

TS workshop  
4 May 2004

## Coil shaping





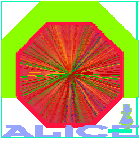

TS workshop  
4 May 2004

# Impregnation mould





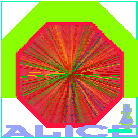

TS workshop  
4 May 2004

Home @ point 2



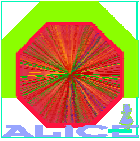

TS workshop  
4 May 2004

## Purpose of the pre-assembly

- ◆ Assembly of the magnet yoke
  - Horizontal factory assembly
- ◆ Installation of the excitation coils
  - Delicate and complex process
- ◆ Determination of electrical and magnetic parameters
  - Complex field geometry of ALICE system
  - Difficult evaluation of EM forces
  
- ◆ Construction of the muon arm platform
  - Detector Services and closure of Solenoid doors on RB 26 side
  - Installation of FASS

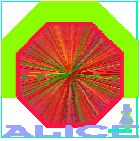

TS workshop  
4 May 2004

# Constraints for final Installation

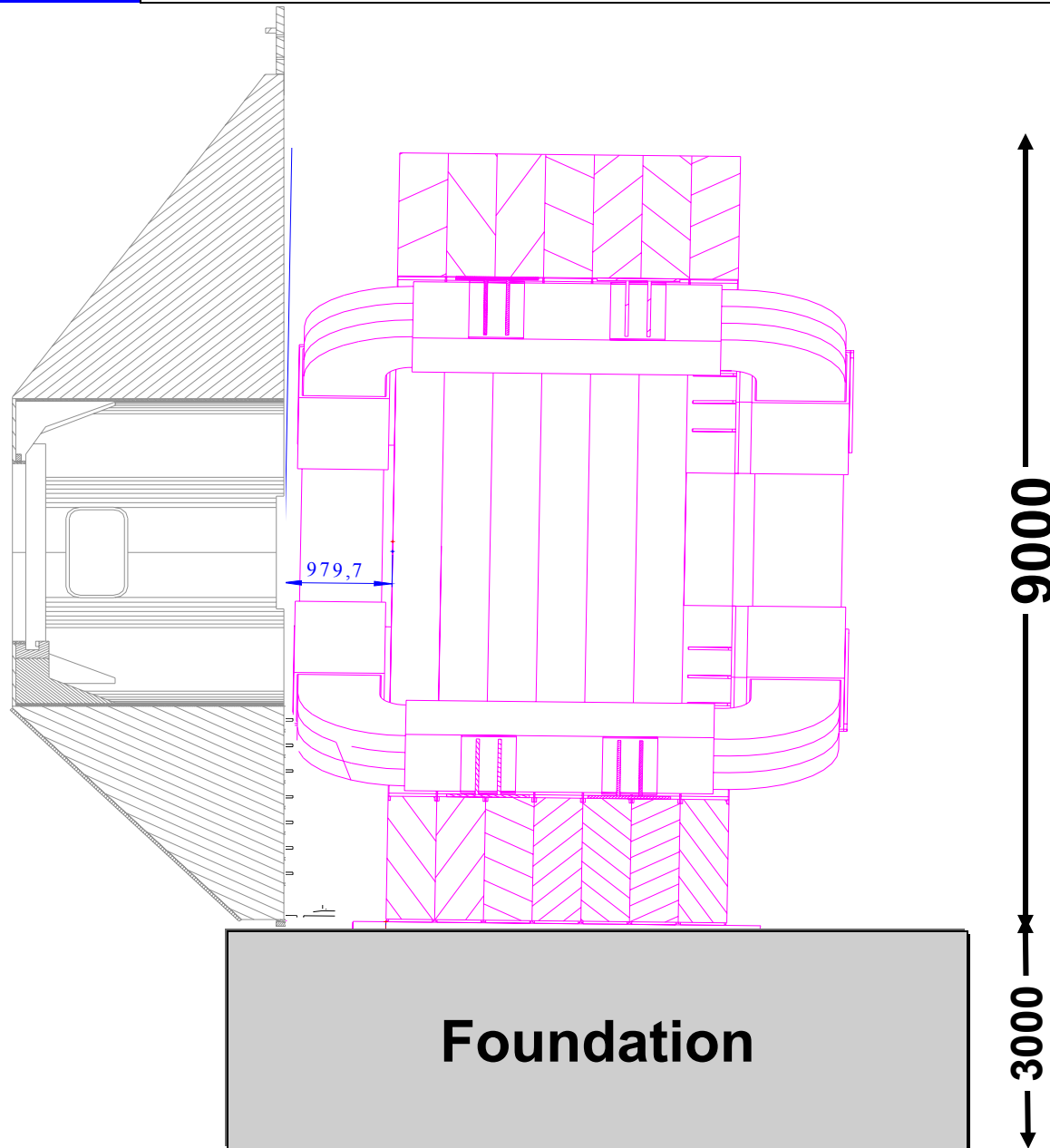



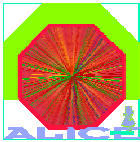

TS workshop  
4 May 2004

# Forces & Operation Modes

Forces Fz on Dipole magnet [kN]			
Op Mode	Force on Coil	Force on Yoke	Net Force
Stand Alone	1456	-1419	37

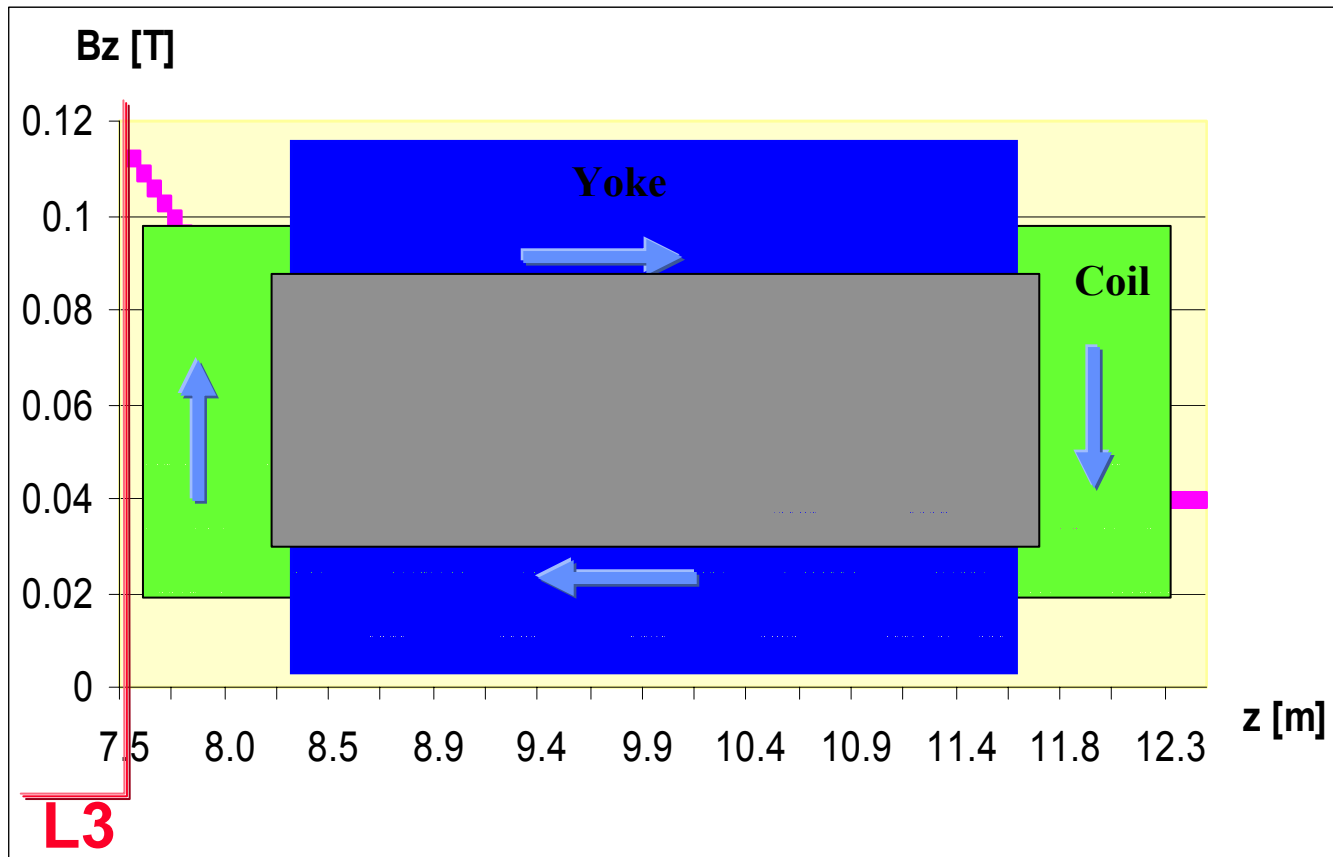

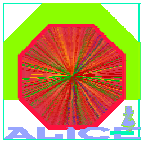

TS workshop  
4 May 2004

# ALICE Dipole Installation

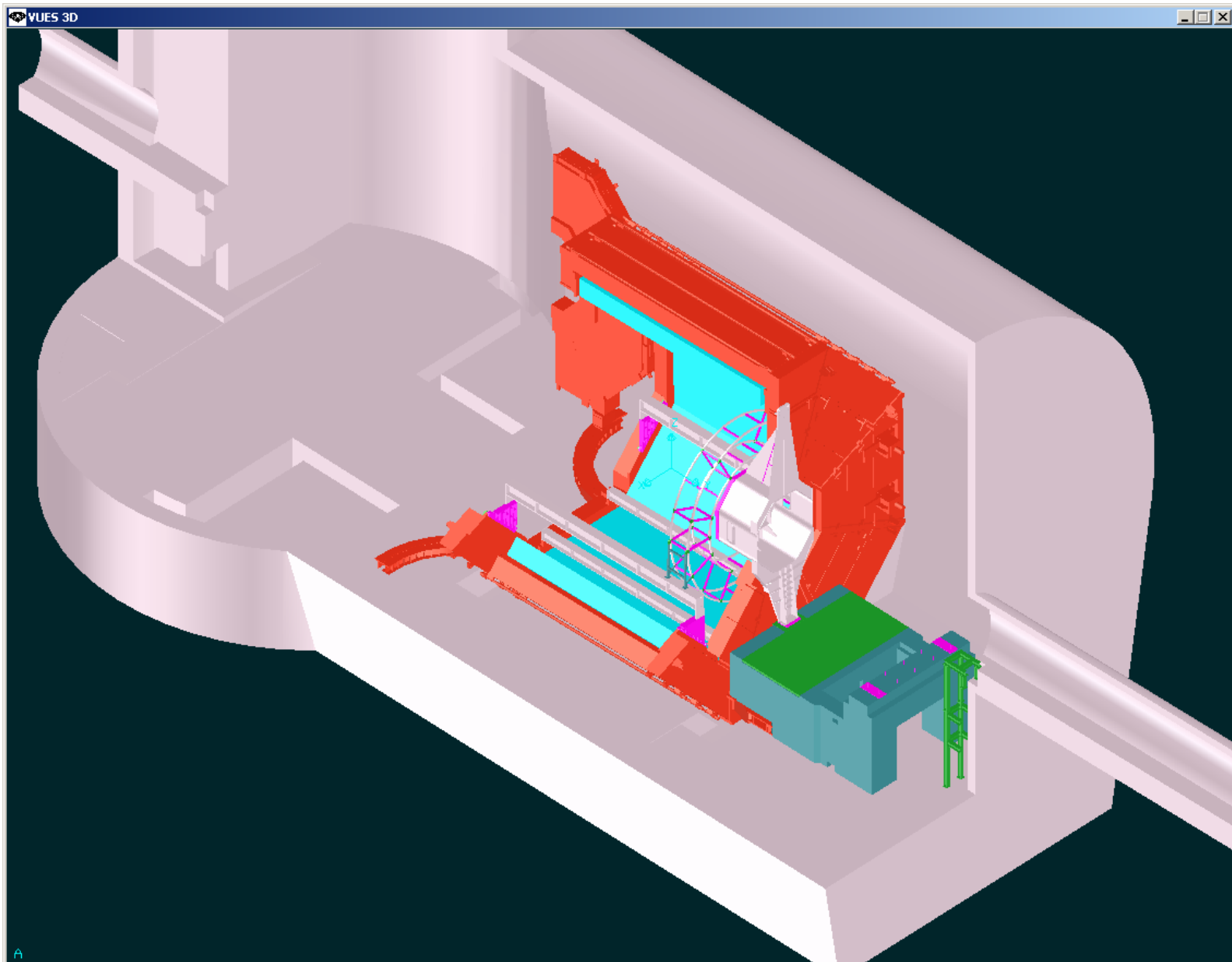



TS workshop  
4 May 2004

# Horizontal Yoke assembly







TS workshop  
4 May 2004

December 2003

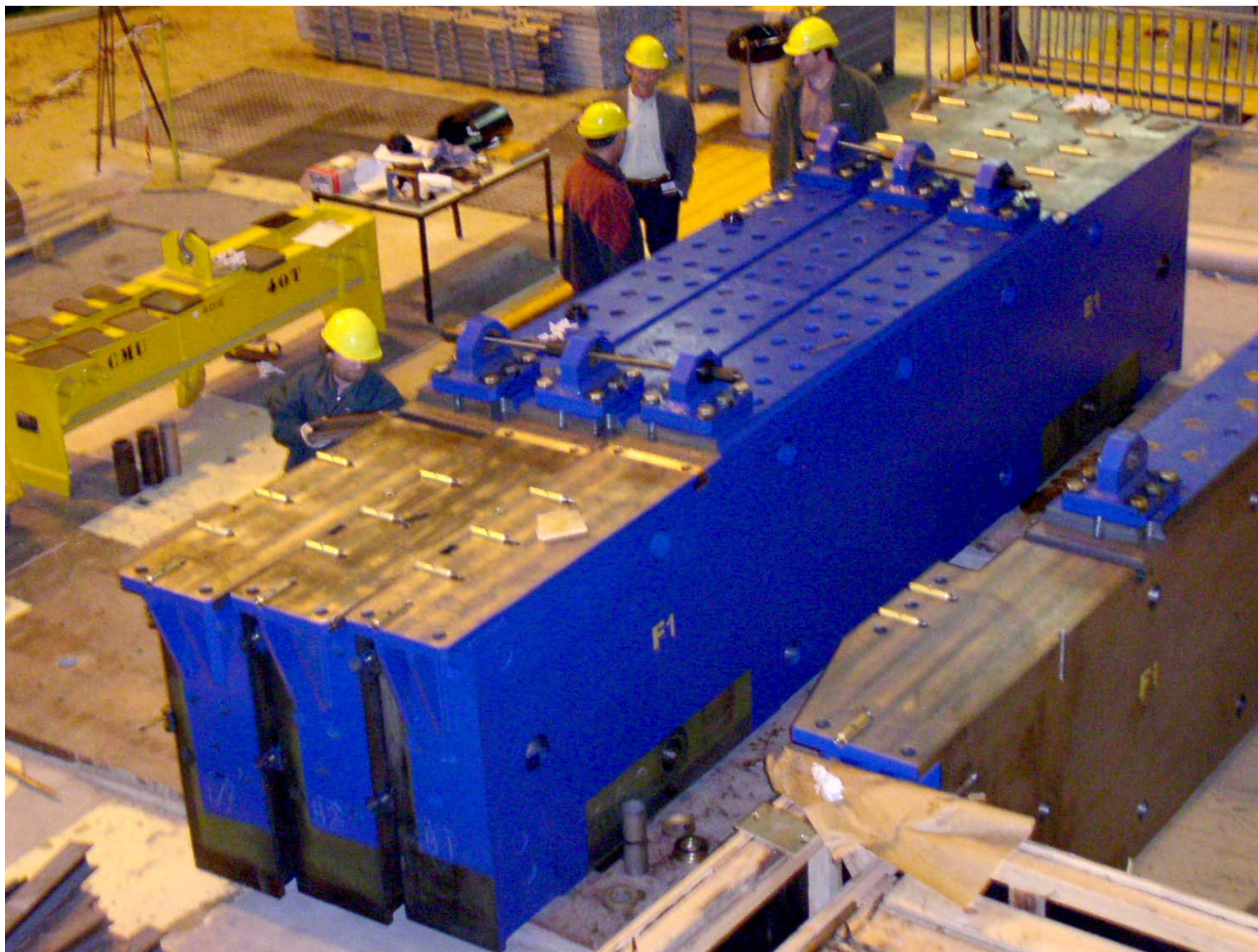

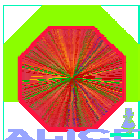

TS workshop  
4 May 2004

## DM assembly frames







TS workshop  
4 May 2004

## DM assembly jig





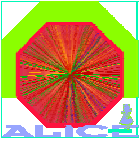

TS workshop  
4 May 2004

# Module Turning





TS workshop  
4 May 2004

# DM yoke frame assembly





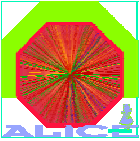

TS workshop  
4 May 2004

26 January 2004

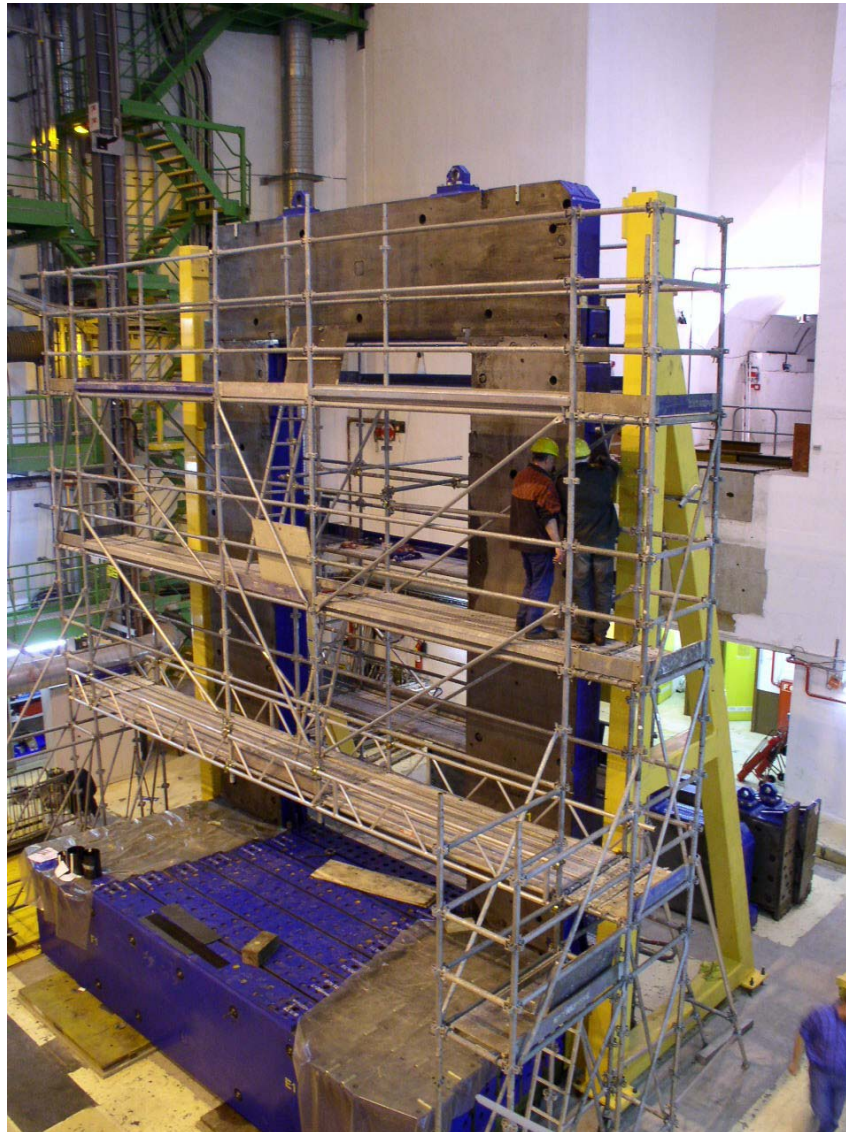



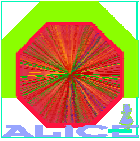

TS workshop  
4 May 2004

19 February 2004





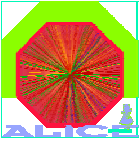

TS workshop  
4 May 2004

19 February 2004

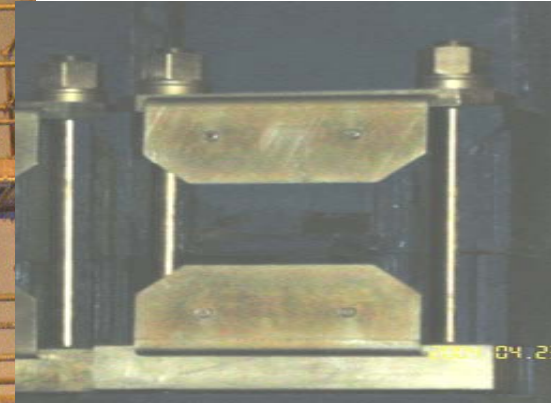

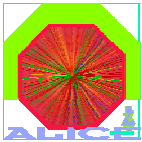

# Coil support Holes

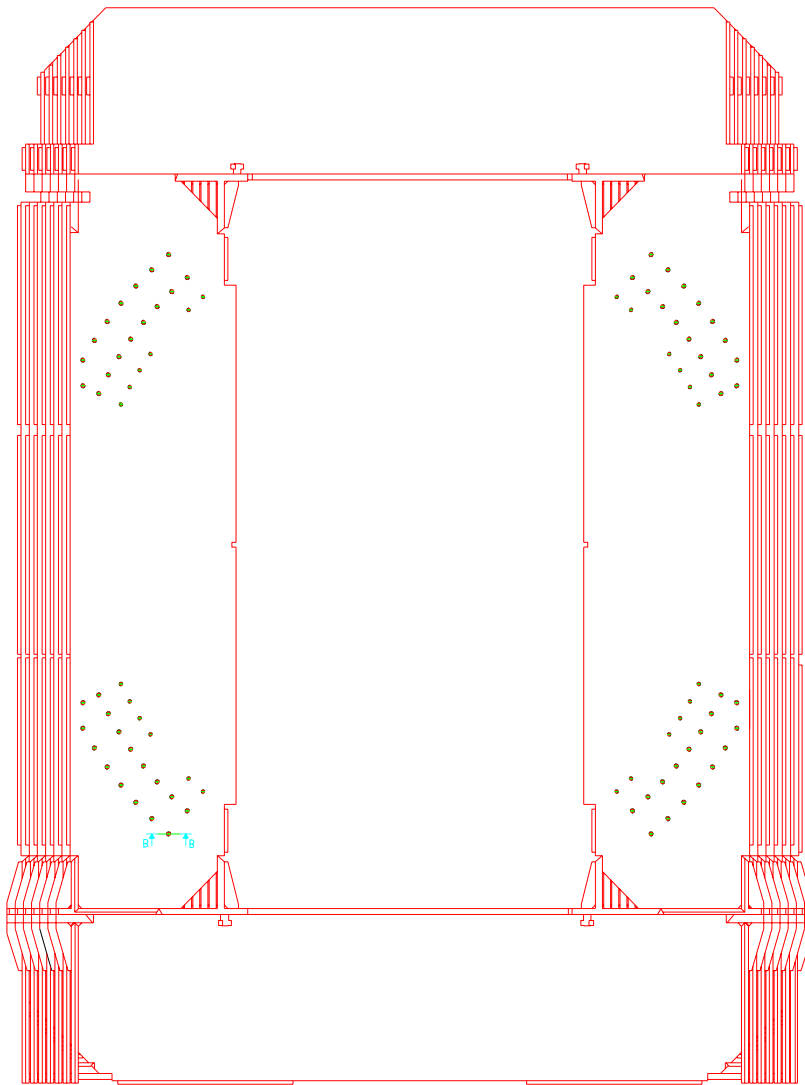

Front	4 x 16 (64)
Rear	4 x 15 (60)
Bottom	4 x 4 (16)
Top	4 x 4 (16)
Total	(156)

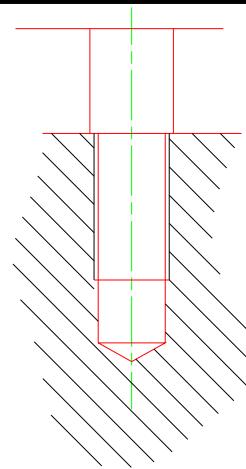

**M36**

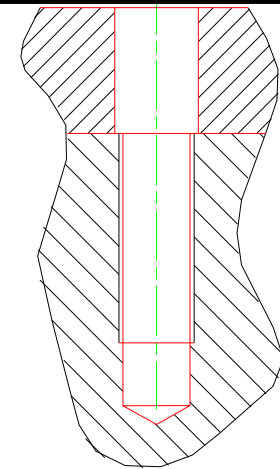

B-B  
Ech 1:2

**M36**



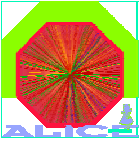

TS workshop  
4 May 2004

# Transport limitations



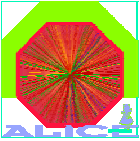

TS workshop  
4 May 2004

# Coil manipulation

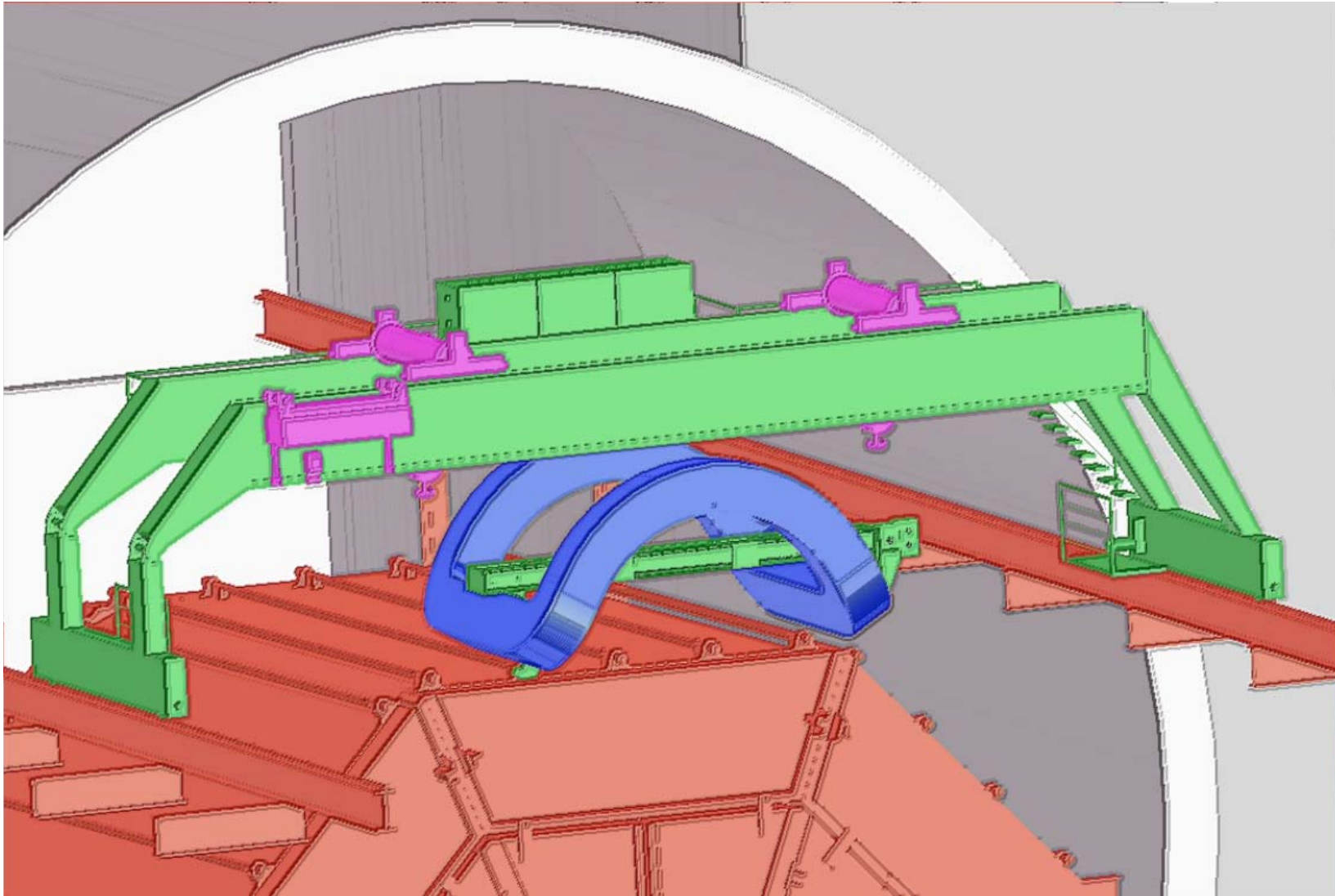



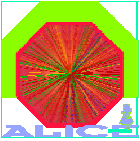

TS workshop  
4 May 2004

## Coil insertion

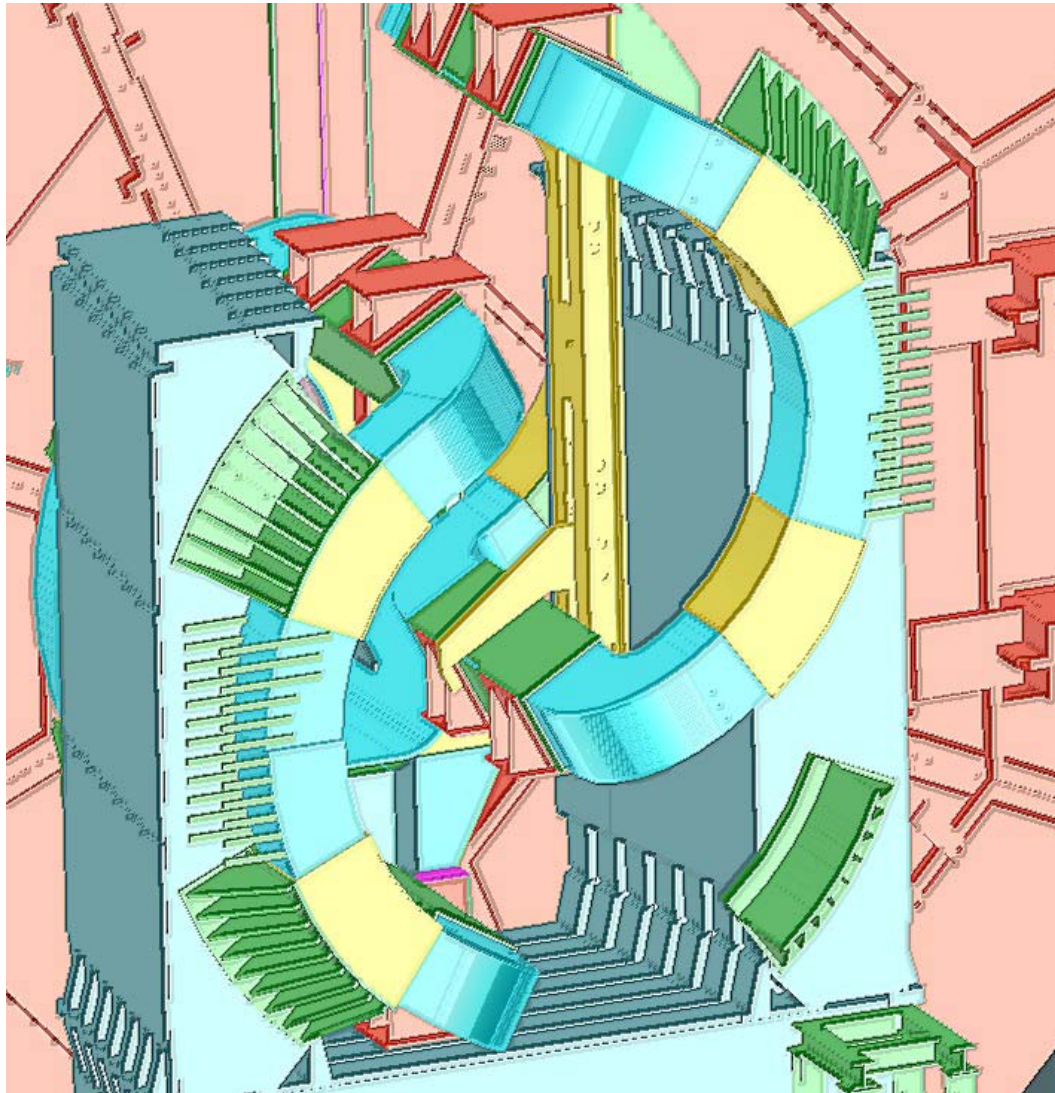



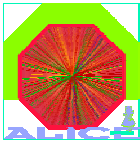



TS workshop  
4 May 2004

## Schedule and Resources

ID		Task Name	Duration	Start	Finish
13		<b>Preassembly UX25/RB24</b>	<b>43 days?</b>	<b>27 Nov '03</b>	<b>18 Feb '04</b>
34		geometry control	5 days	19 Feb '04	25 Feb '04
35		<b>Coil consolidation</b>	<b>47 days</b>	<b>26 Feb '04</b>	<b>30 Apr '04</b>
40		<b>Machining holes for supports</b>	<b>54 days?</b>	<b>29 Mar '04</b>	<b>10 Jun '04</b>
47		removal of yoke top	7 days?	27 May '04	4 Jun '04
55		coil supports	6 days?	7 Jun '04	14 Jun '04
58	 	coil installation	17 days	15 Jun '04	7 Jul '04
63		reinstall yoke top	7 days?	8 Jul '04	16 Jul '04
71		proximity services	16 days	19 Jul '04	9 Aug '04

Type	Strength	From	To
JINR	4	Nov. 03	Feb. 04
Temp. Labour	3	Mar. 04	May 04
PA (St. Petersburg.)	1	2003	2004

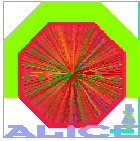

TS workshop  
4 May 2004

# Final assembly planning

ID		Task Name	Duration	Start	Finish
66		<b>Final Assembly UX25/RB26</b>	<b>84 days?</b>	<b>4 Oct '04</b>	<b>10 Feb '05</b>
67		Dipole Magnet dis-assembly in RB24	17 days	4 Oct '04	26 Oct '04
72		Yoke base assembly	6 days?	27 Oct '04	3 Nov '04
73		Poles and Yoke Top assembly	22 days?	4 Nov '04	3 Dec '04
74		Removal of Yoke Top	6 days?	6 Dec '04	13 Dec '04
75		Coil supports	6 days?	14 Dec '04	4 Jan '05
76		Coil installation	10 days?	5 Jan '05	18 Jan '05
77		Reinstall Yoke Top	6 days?	19 Jan '05	26 Jan '05
78		Proximity Services	10 days?	27 Jan '05	9 Feb '05
79		Power up of Dipole magnet	1 day?	10 Feb '05	10 Feb '05

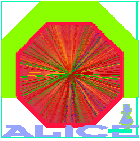

- ◆ Geometry
  - Overall dimensions and acceptance
- ◆ Power and cooling
  - All electrical and magnetic parameters
  - Cooling performance and temperature profile in detector volume
  - Demagnetization and polarity switch
- ◆ Mechanical strains and deformations



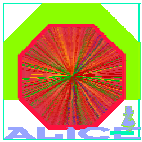

TS workshop  
4 May 2004

# Thanks to the Team

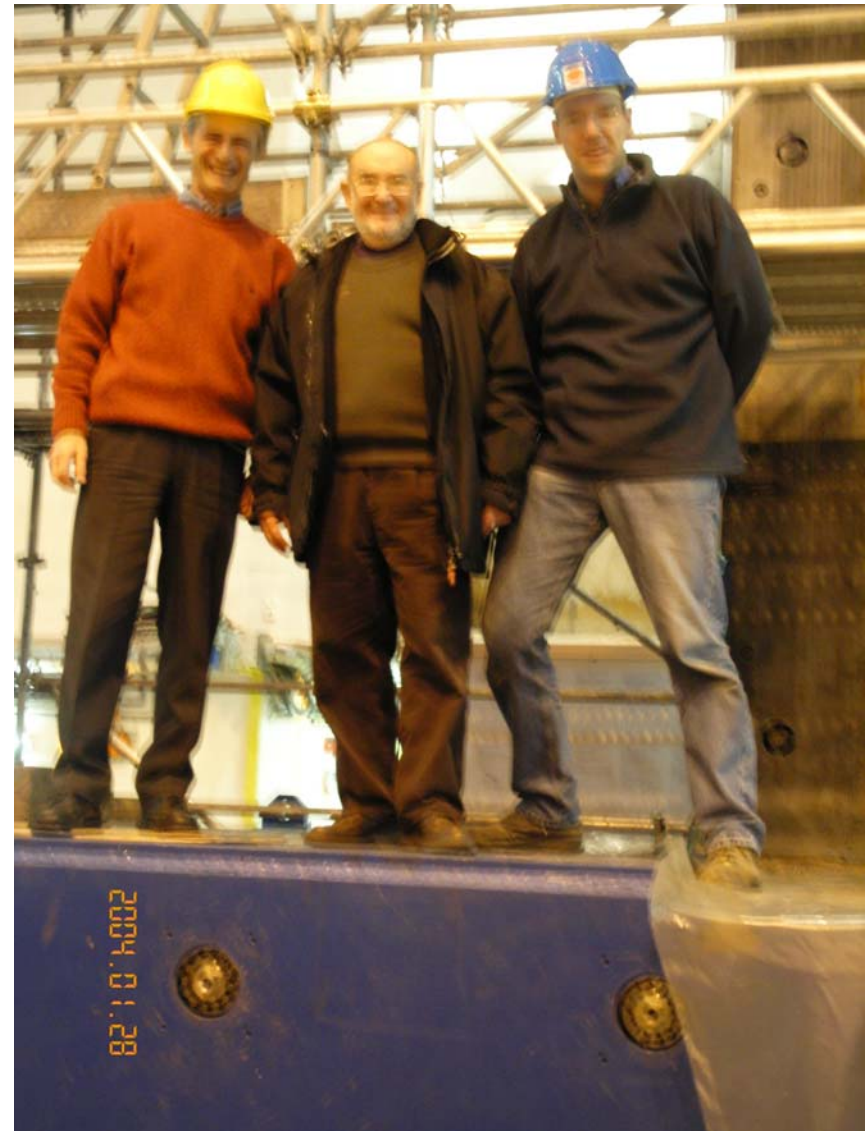

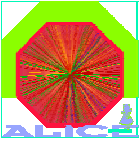

- ◆ Space restrictions at final location
  - Assembly procedure corrected & validated
- ◆ Handling constraints at final location
  - No further machining required
  - Handling jigs tested
- ◆ Pre-commissioning
  - Verification of key parameters
  - Monitoring of forces, deformations and temperatures
- ◆ Precise installation planning after pre-assembly
  - Full tooling set on hand
  - All services pre-installed
  - Known set of geometry and alignment references

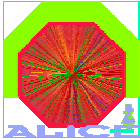

# Ripple

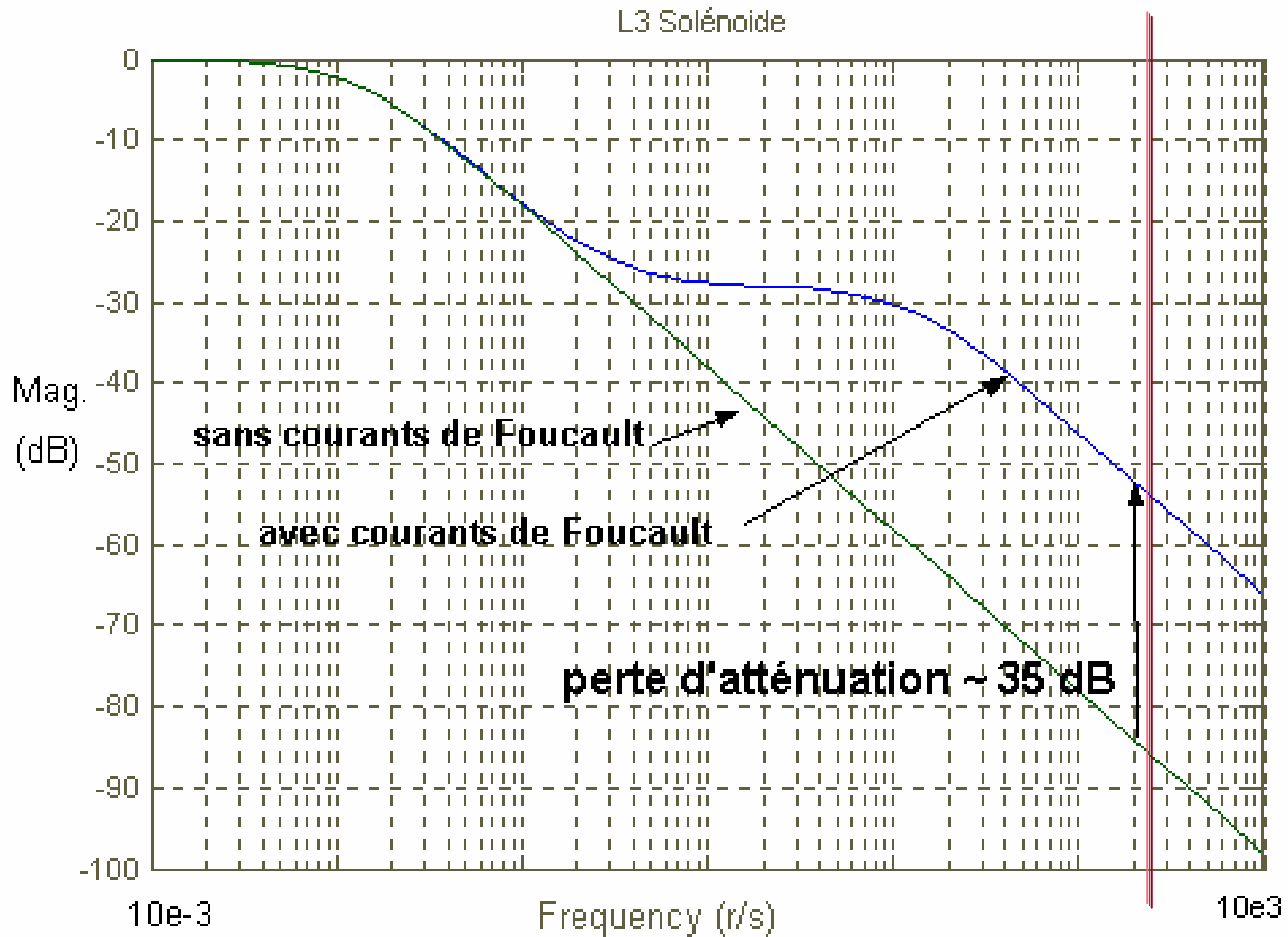



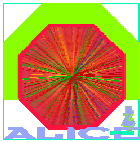

Frequency	$\Delta V$	$\Delta I$	$\Delta I/I_{\max}$
50 Hz	2 V	~ 6.4 mA	$5.8 * 10^{-5}$
600 Hz	8 V	~ 2.1 mA	$1.9 * 10^{-5}$

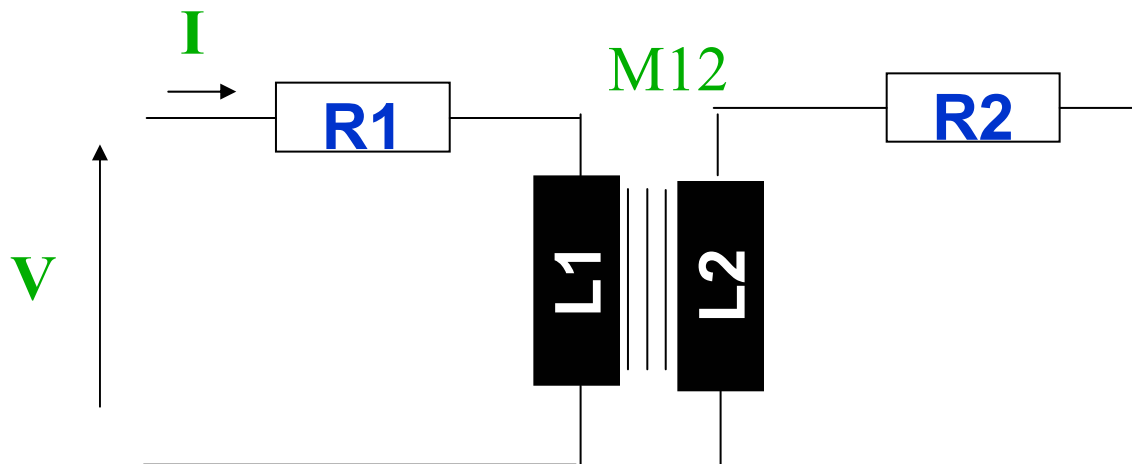

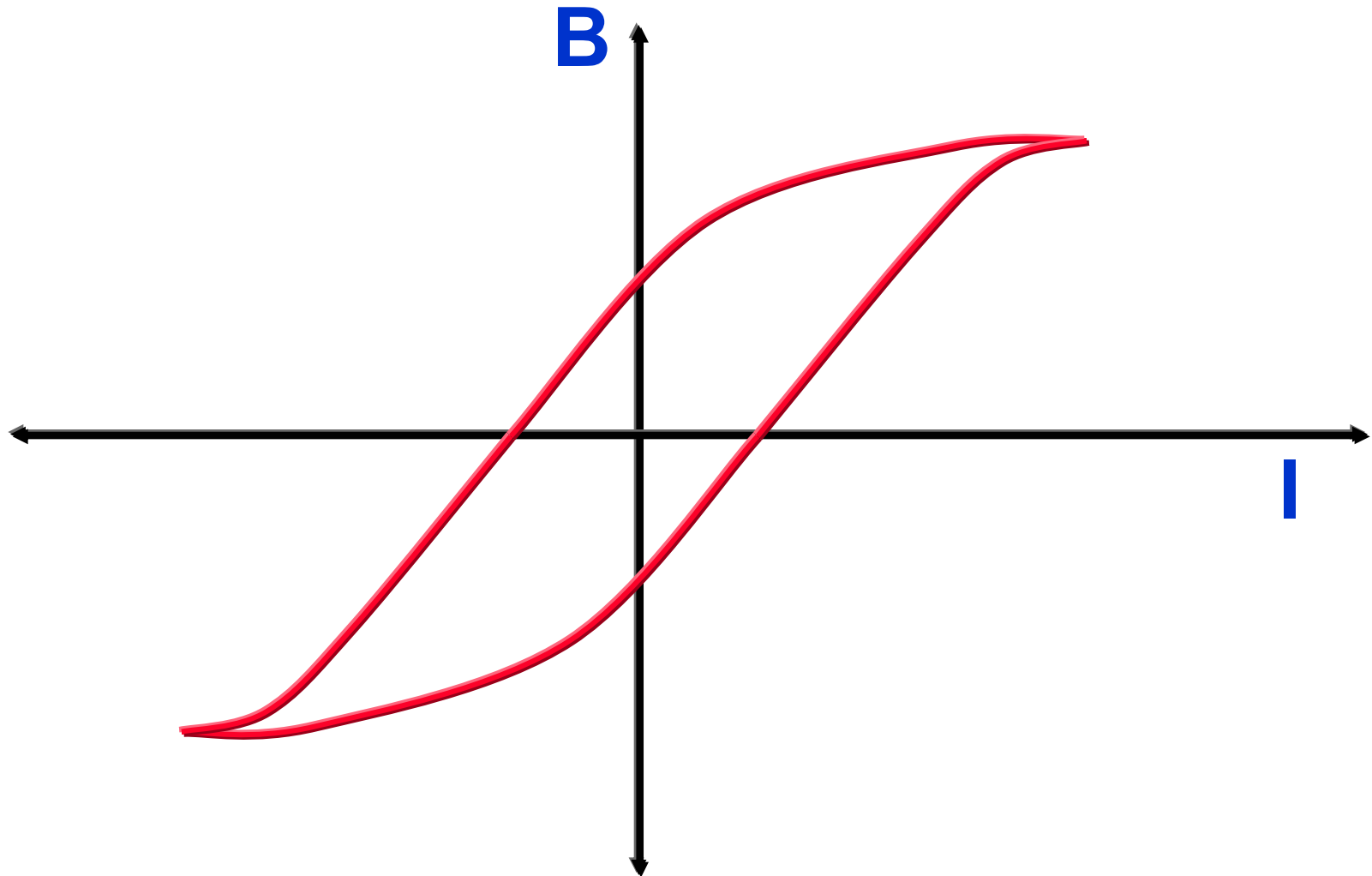

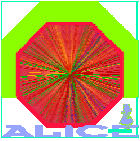

TS workshop  
4 May 2004

# Electrical connection concept

