

The Search for Neutral Higgs Bosons at DØ

Andy Haas
Columbia University
DØ/ATLAS Experiments

TeV4LHC @ CERN
Higgs / Landscape
April 29, 2005

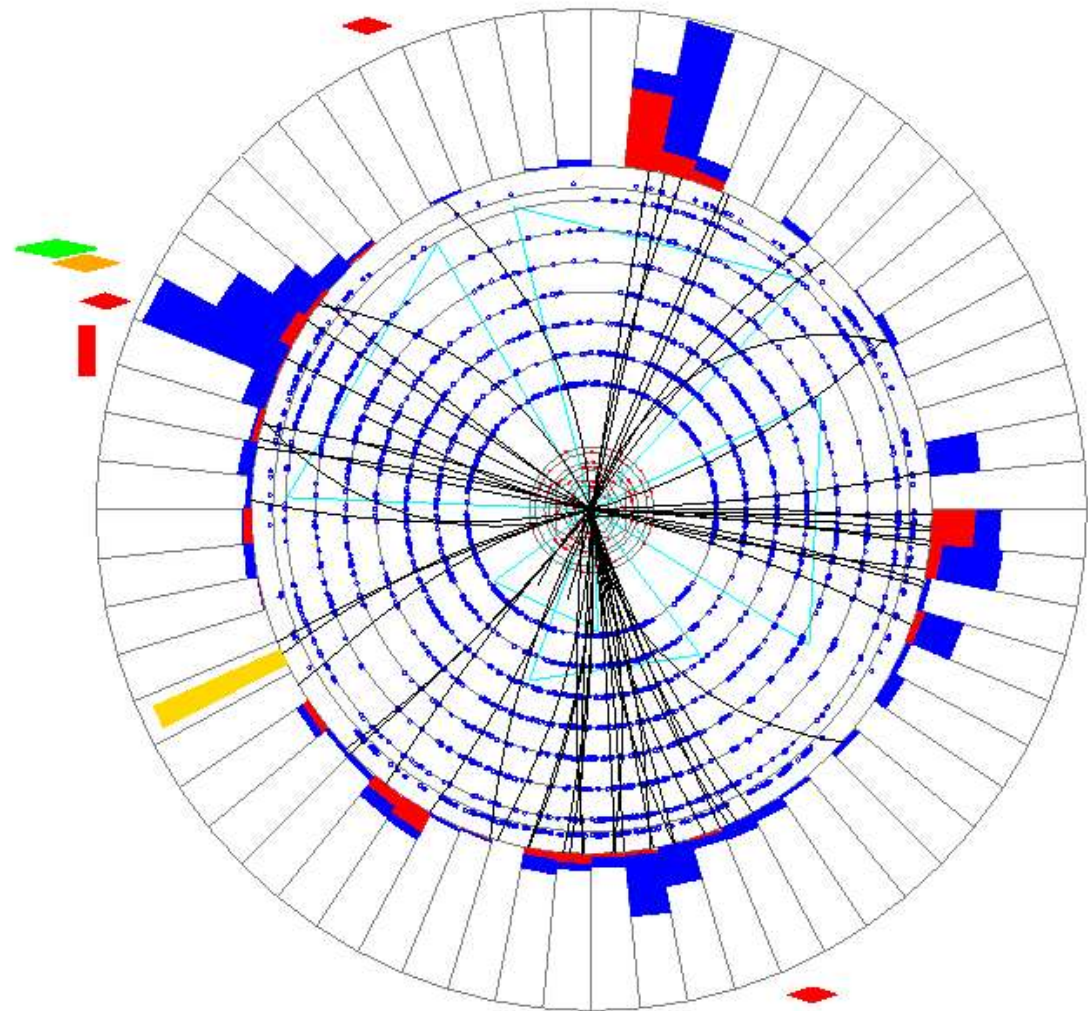

- Boson and fermion loop integral contributions differ by a factor of (-1)
 - A fermion for every boson: scalar field masses are stabilized
- Nobody works at Boselab...
Supersymmetry is slightly broken
- Supersymmetry demands an even number of Higgs doublets
 - A light Higgs is predicted ($m_h < m_z$ at tree-level)
 - With 2 Higgs doublets, couplings unify at 10^{16} GeV
 - This is the MSSM

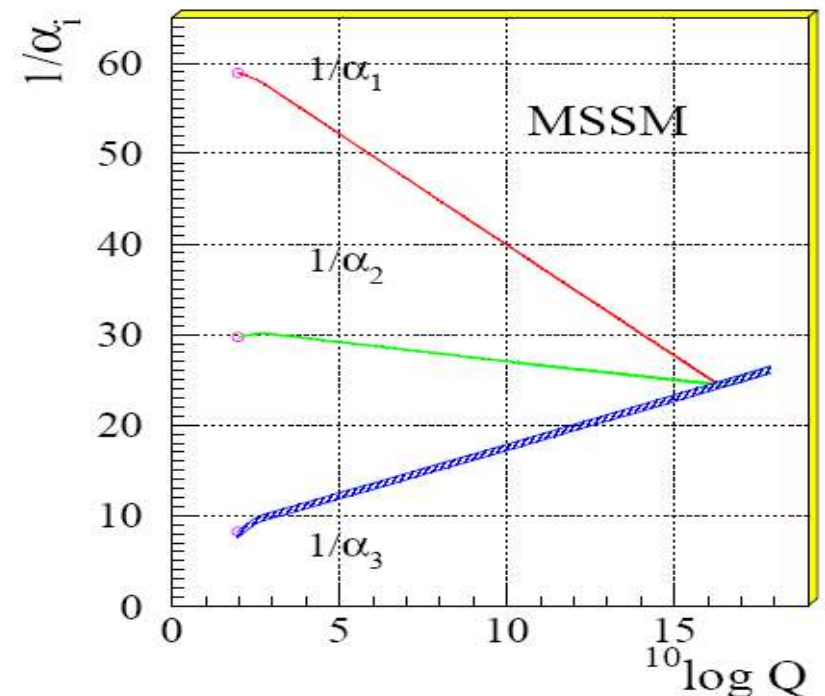
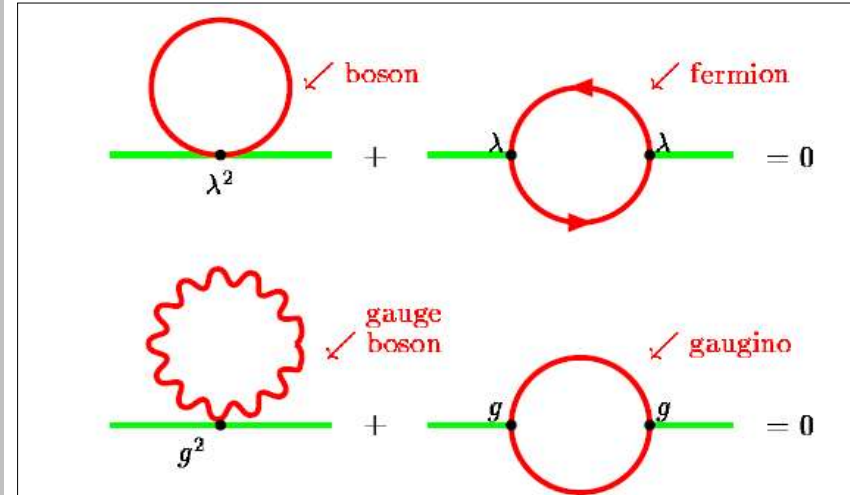

Higgses in Supersymmetry

- Higgs fields come in pairs (H_u and H_d)
- 5 Higgs bosons : h, H, A, H^+, H^-
- $\tan\beta = H_u / H_d$
 - At $\tan\beta \sim 50$, coupling of A to $b = A$ to t
 - Cross-sections for bbh grow like $\tan^2\beta$!
- h is predicted to be light, $< \sim 135$ GeV
 - LEP limits on Higgs mass -- 92 GeV (not the usual 114 GeV like in the SM...)
 - LEP limits are much looser (~ 50 GeV) if CP-violation is allowed in the Higgs sector... this talk assumes CP-conserving Higgses !
- At high $\tan\beta$ ($> \sim 20$), the A is degenerate with the h, H :
 - $cs(A) \sim cs(h/H)$
 - $width(A) \sim width(h/H)$
 - $m(A) \sim m(h/H)$
 - $BR(A \rightarrow bb) \sim BR(h/H \rightarrow bb) \sim 90\%$

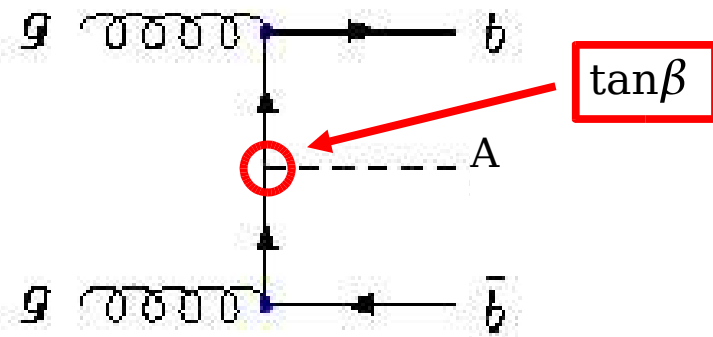
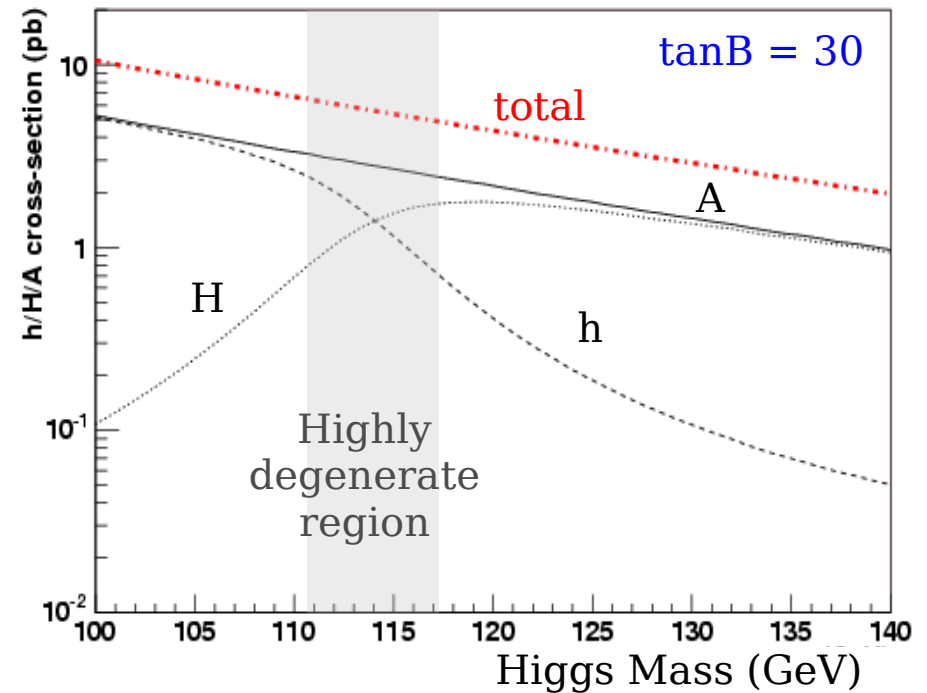

Higgs Widths

- Higgs bosons get wider, proportional to $\tan^2\beta$
- Widths are modeled with BW shape, weighted by cross-section
- Not a large effect on sensitivity, for reasonable $\tan\beta$ values, after considering kinematic criteria
- See Marine's talk!

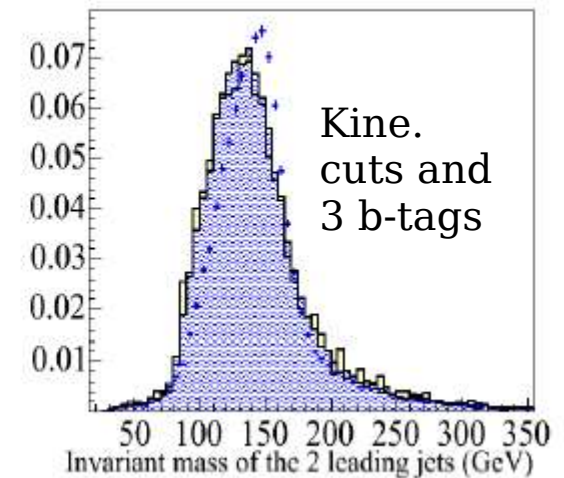
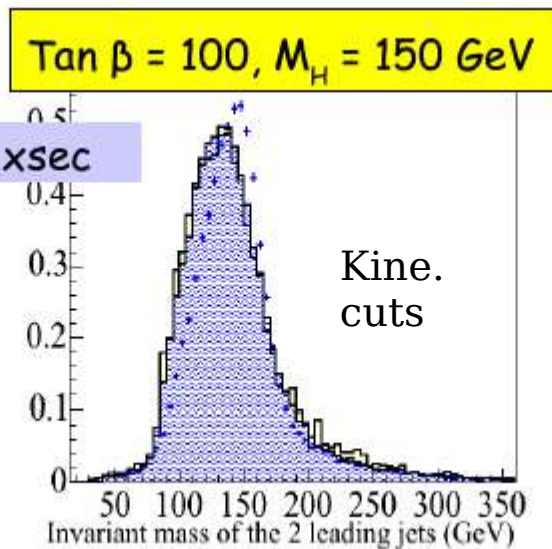
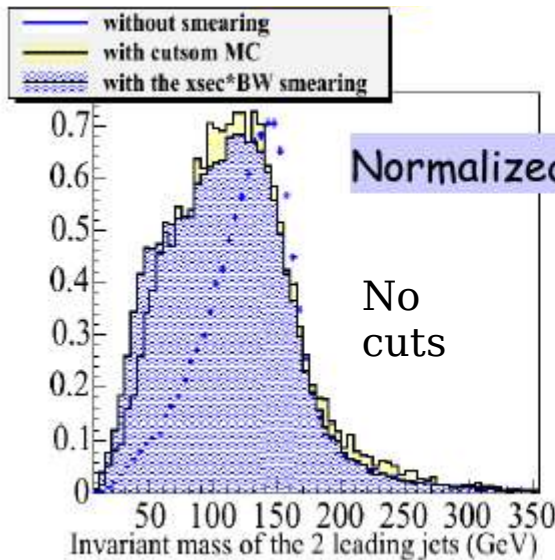
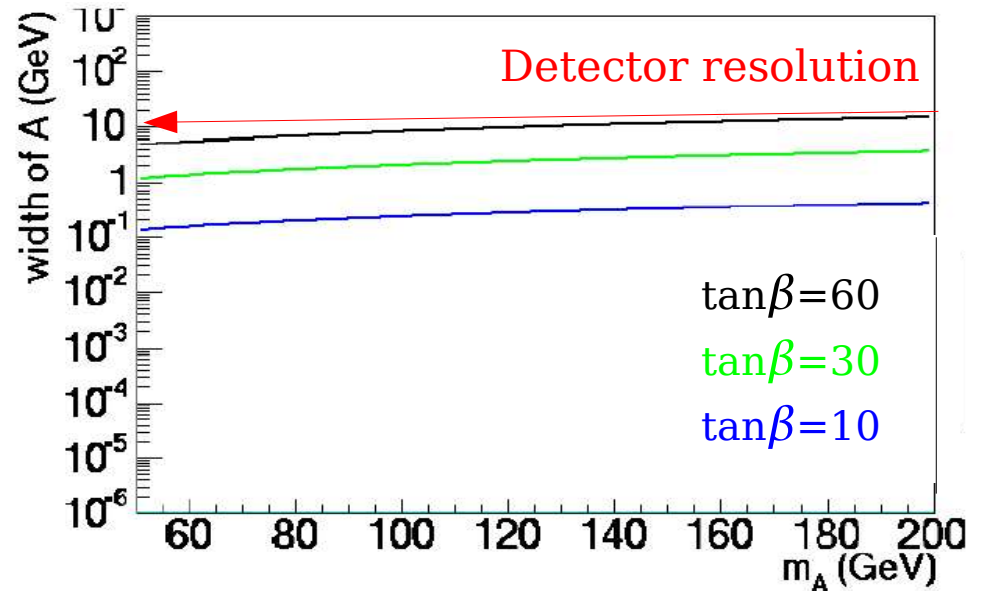

Mass-splitting of the Higgses

- What about when all 3 Higgs are nearly degenerate?
 - What matters is the shape and height of the invariant mass peak
- When cross-sections are significant, the mass-splitting is small compared to the detector resolution

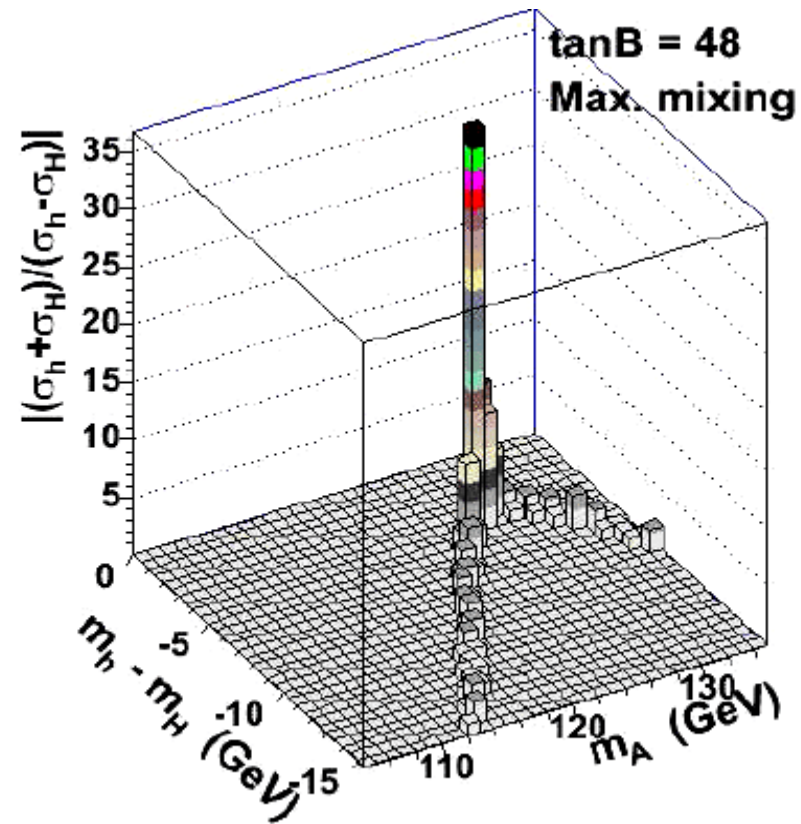
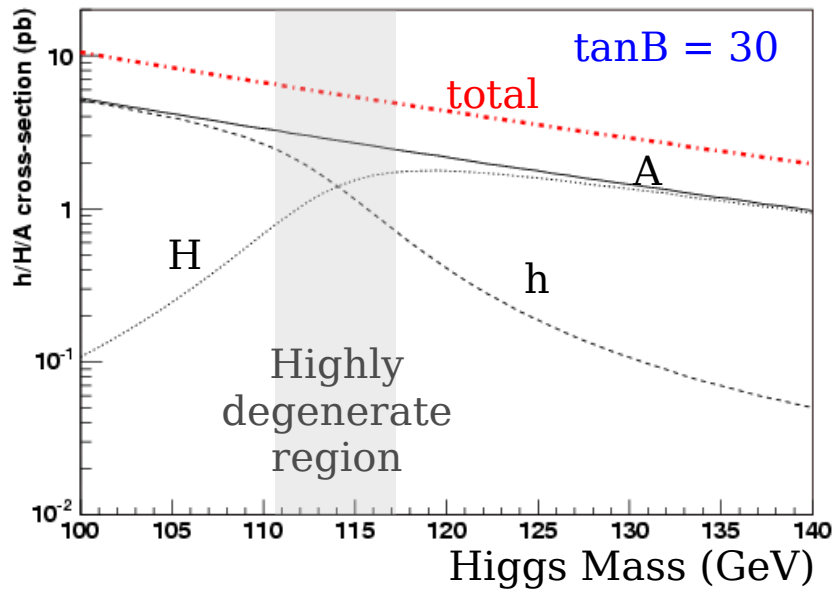

Mass splitting, weighted by inverse cross-section difference, of h and H

Signal at NLO in QCD

- There are two ways to calculate the signal production at a ppbar collider:
 - ppbar->bbh (4-flavor scheme)
 - ppbar->bh (5-flavor scheme) : use b-PDF
- Both methods now agree at NLO
- Uncertainties from PDF are comparable in size
- D0 has performed a measurement to test the predictions of the b-quark PDF calculations
 - Z+b / Z+j

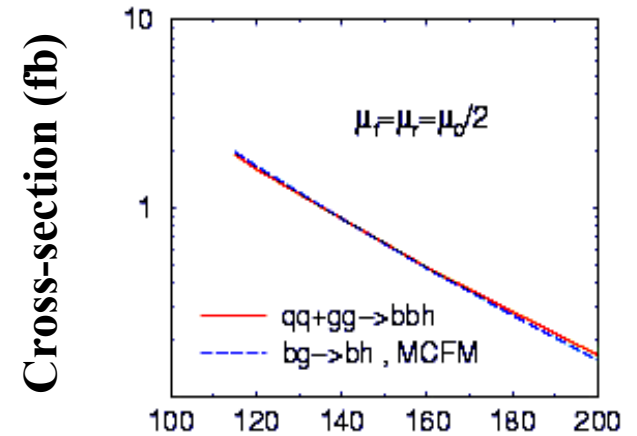
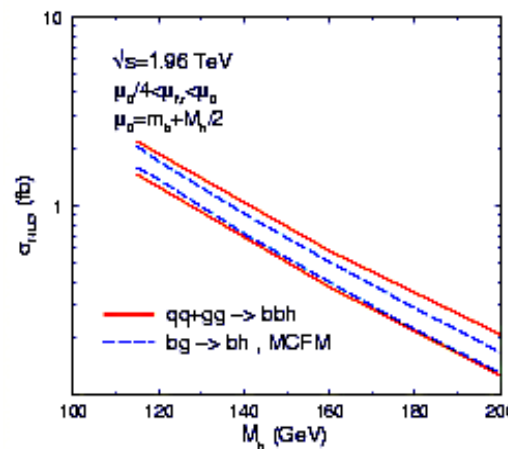
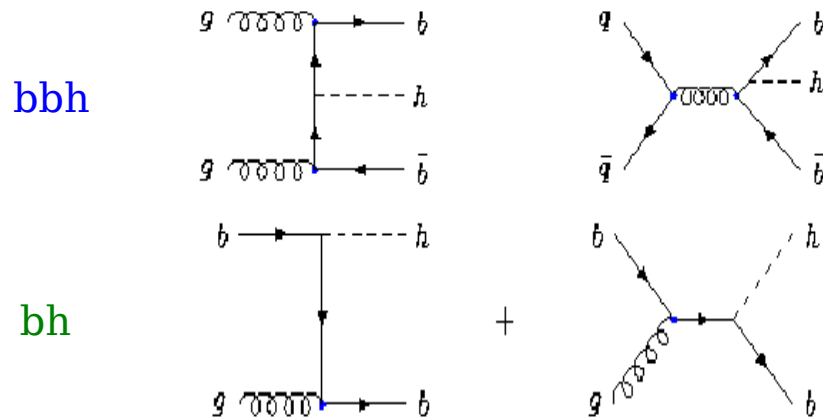

Z+b is a probe of b-quark PDF \Rightarrow
 $\sigma(\text{Z+b}) / \sigma(\text{Z+j}) = 0.023 \pm 0.005$
 $= 0.018$ (CTEQ6 prediction)
 (DØ - hep-ex/0410078) - PRL. 94, 161801 (2005).

Monte Carlo Higgs Spectra

- Our Monte Carlo uses Pythia, which is semi-leading-order
- The events have been re-weighted, to mimic the NLO kinematics as closely as possible
- Comparisons of the bh and bbh processes are in good agreement

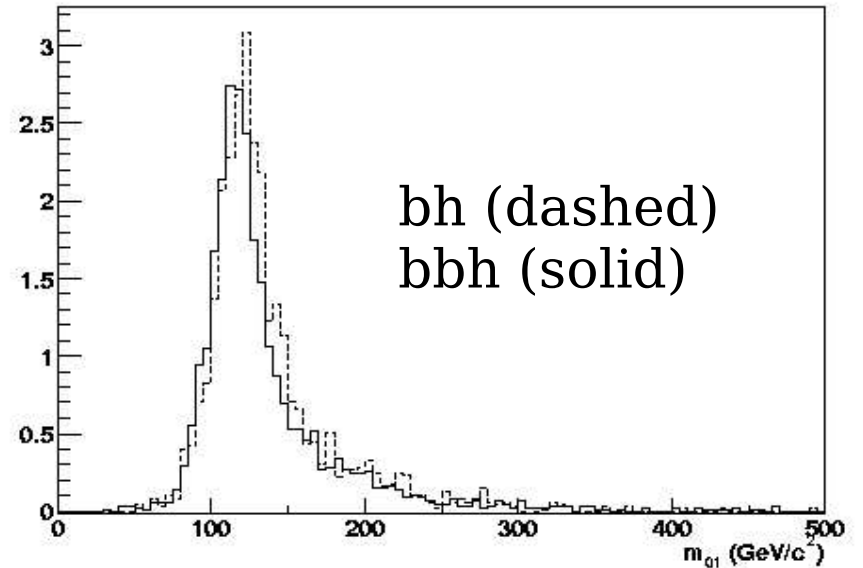
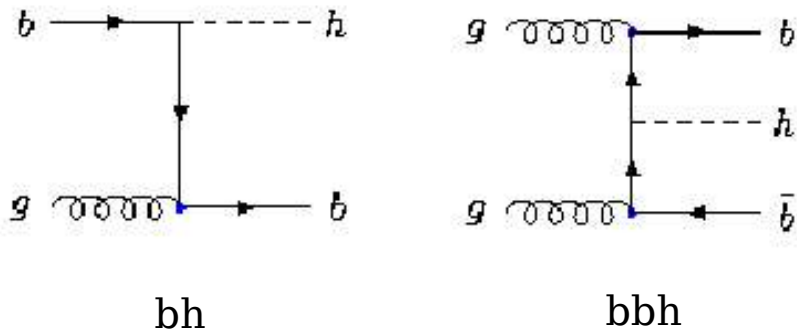
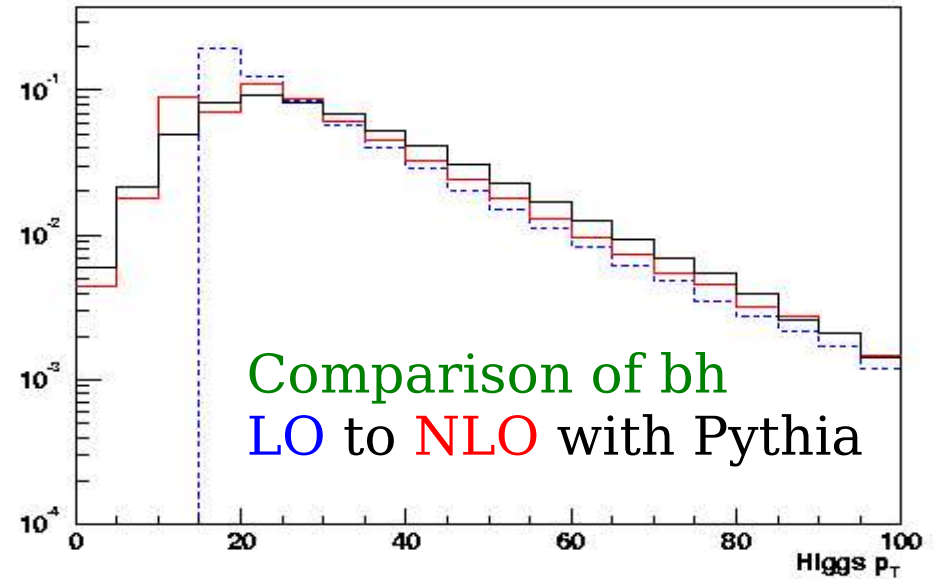

Current Detector Data / Efficiency

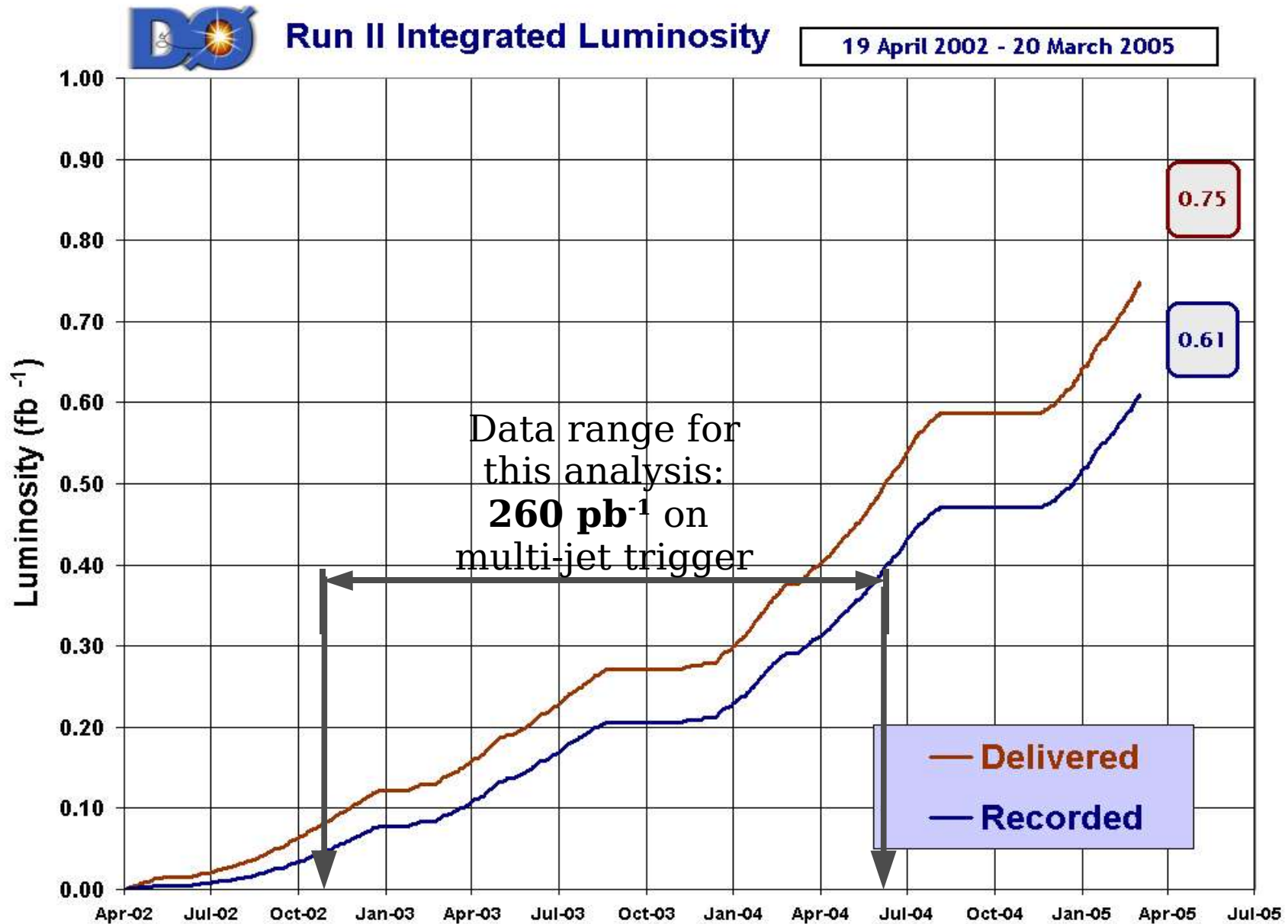

- Custom multi-jet triggers

- Level 1:
Three towers with TOT $E_T > 5$ GeV
- Level 2:
Three clusters with $E_T > 8$ GeV
and $H_T > 50$ GeV

- Each triggerlist had new Level 3 criteria, as we improved them to remain within bandwidth limits while retaining signal efficiency

Three jets with $E_T > 15$ GeV with two above 25 GeV in $|\eta| < 3.0$
Jets use 0.5 cone algorithm and PV Z position to correct jet E_T and η
Require a good L3 PV with $|z| < 35$ cm

- 260pb⁻¹ of good data
- 87.5 Million events

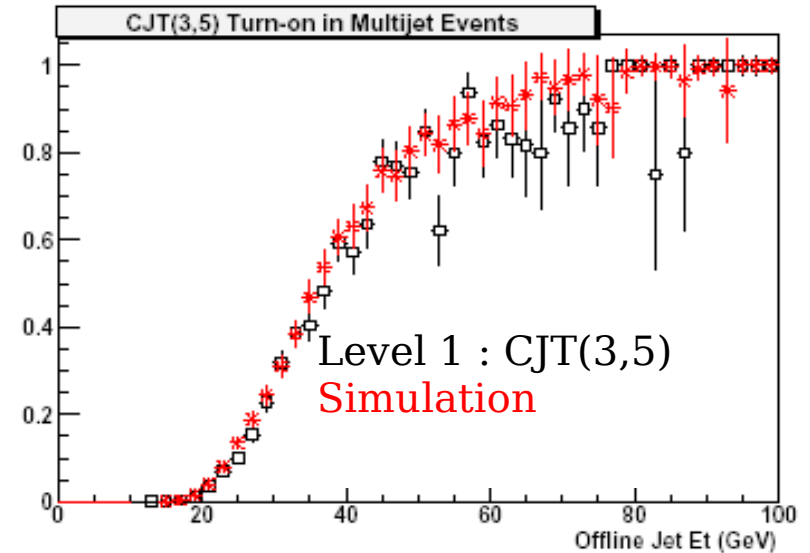

Trigger efficiencies measured using data:

- > mu-based unbiased trigger for L1/L2
- > special run for L3 study

68-80% efficient for m_A of 90-150 GeV

Tracking Systems

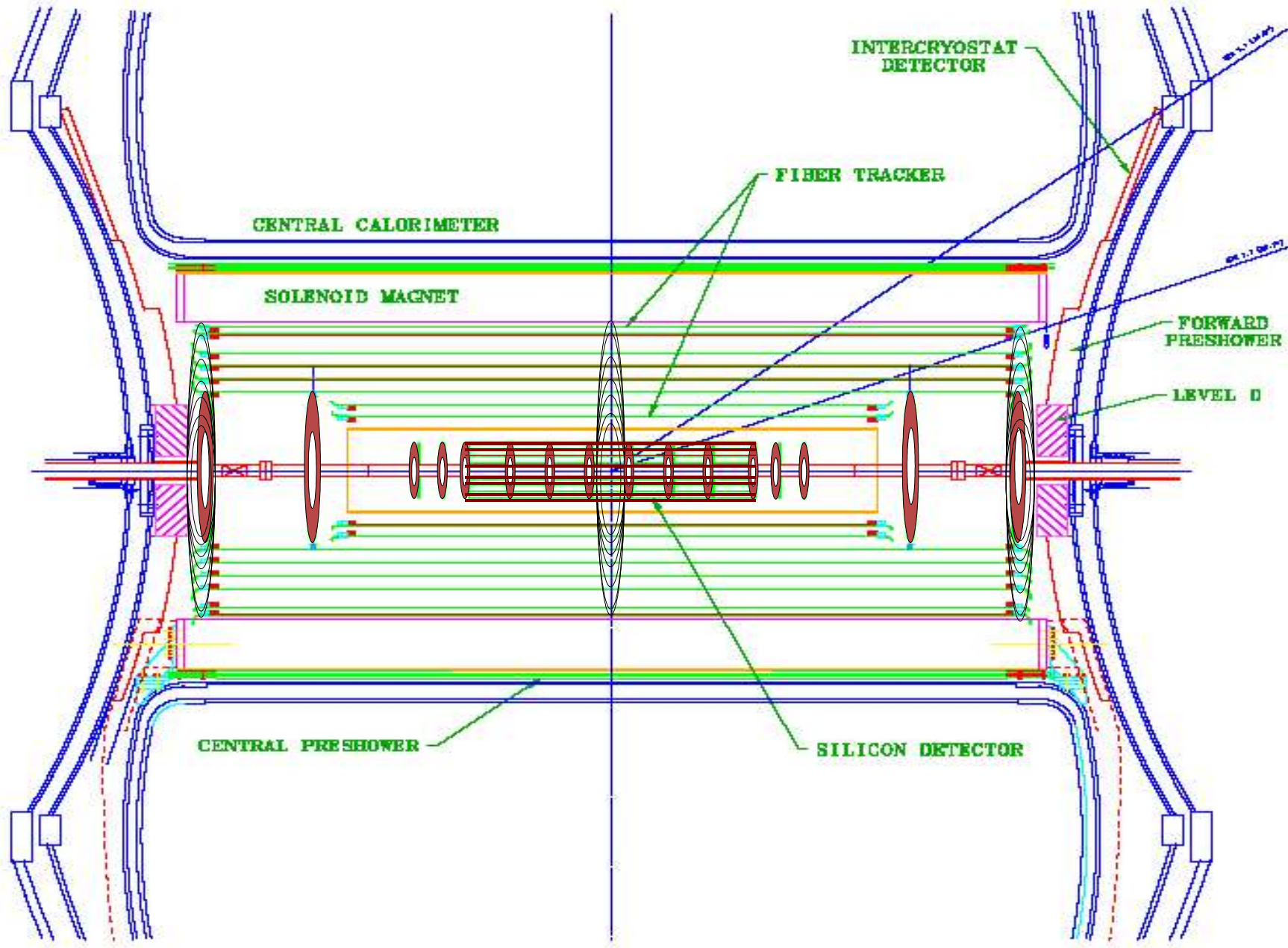

Track Reconstruction

- Efficiency for $p_T > 1 \text{ GeV}$ is about 95% in the central region, 85% for the forward
- Impact parameter resolution is ~ 20 microns
- Will continue to improve with better alignment and understanding of material

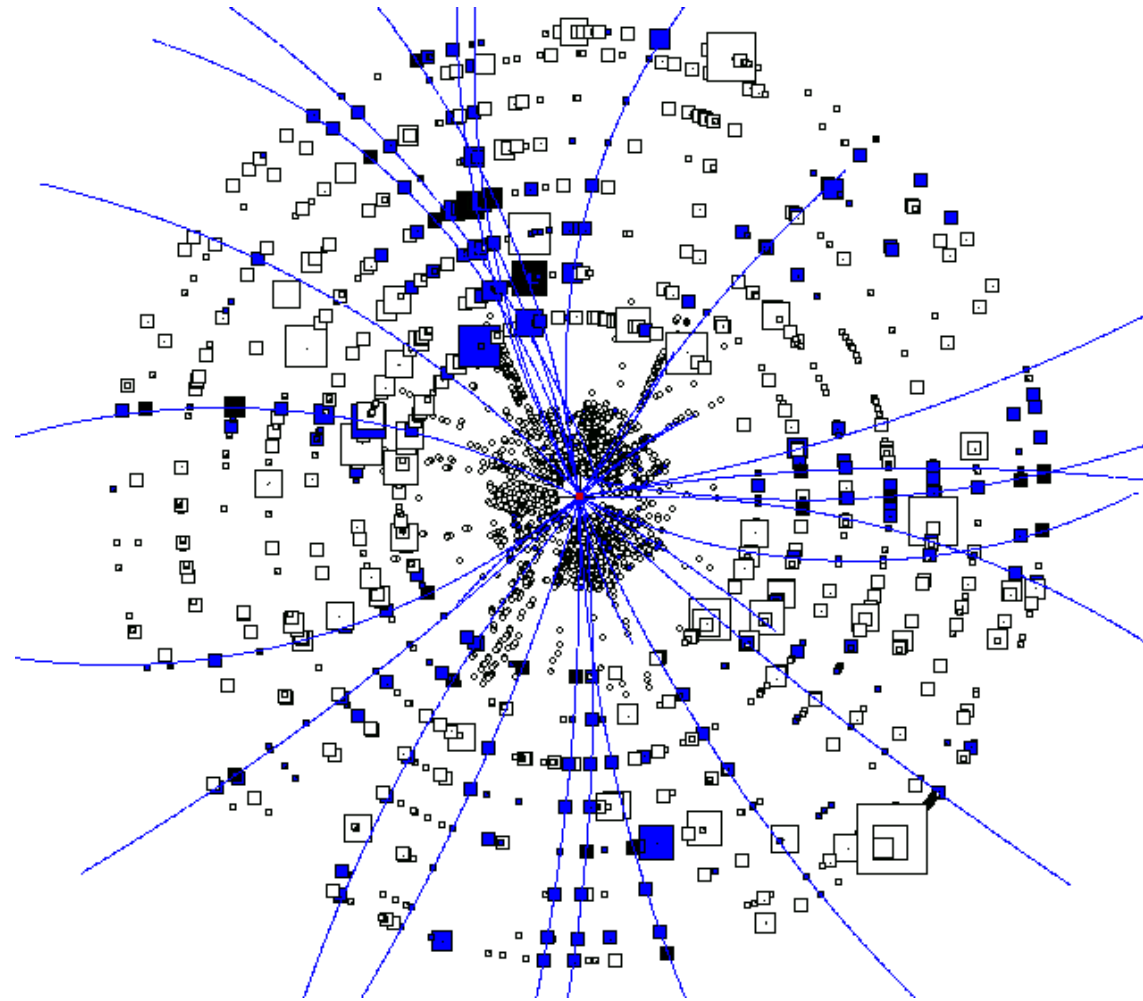

An axial view of a 3-jet event in data, with reconstructed clusters and tracks

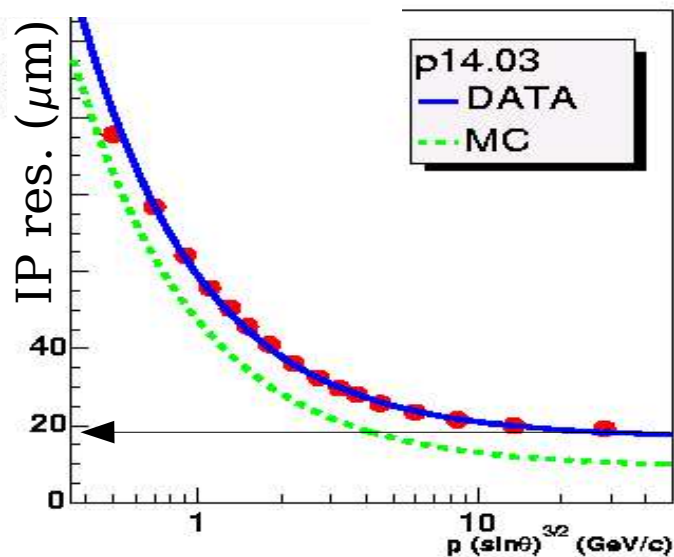

Primary Vertex Reconstruction

- Common locations of tracks along the beam-line are clustered into “primary vertices”
- There can be more than one interaction in a crossing
 - Very unlikely to have more than one interesting event in a single crossing
 - About 0.4 interactions per crossing on average for this data set - depends on instantaneous luminosity
- The interesting vertex is selected based on the momenta of the vertices' tracks
- This “hard-scatter” primary vertex is used to calculate jet E_T

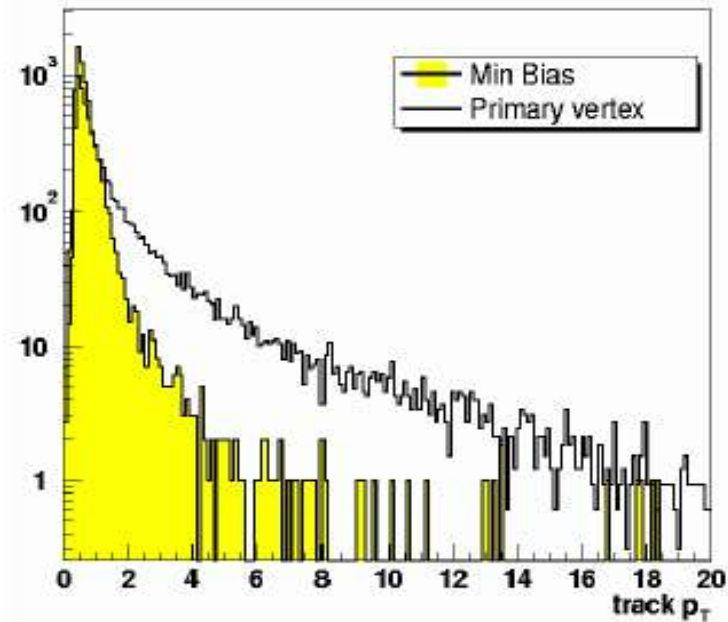
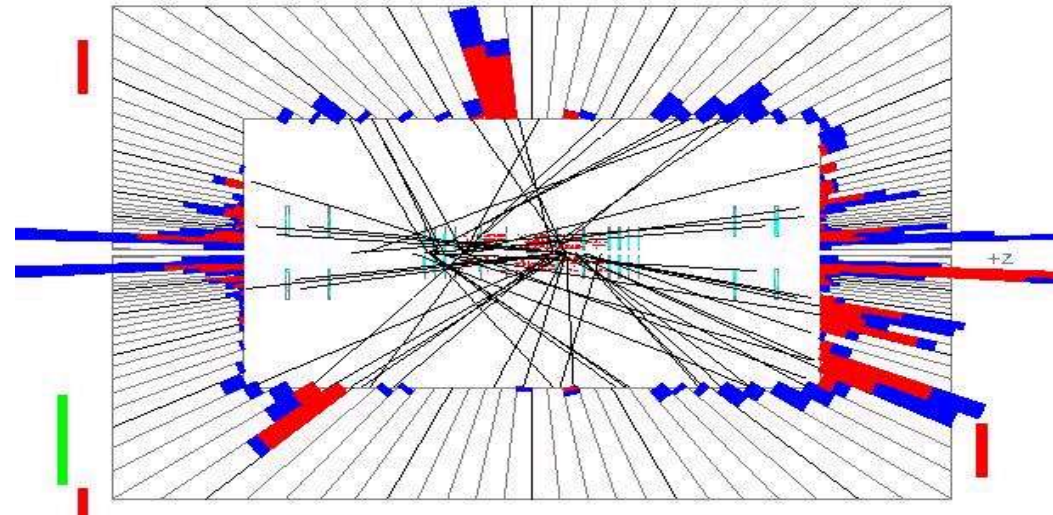

b-Jet Identification

- Identify jets containing **bottom hadrons**
 - main weapon against the huge QCD background
 - b-hadrons travel ~ 3 mm before decaying
 - Their mass leads to an opening angle between tracks --- large IP significances
 - Additional large IP significance tracks may arise from **daughter decays (charms, tau)**
- High-IP-significance tracks are used to find the secondary vertex(es)
 - Jets with a secondary vertex in $\Delta R < 0.5$ are “tagged” as b-jets
- Backgrounds consist of:
 - mis-tags: poorly reconstructed tracks which randomly happen to form a vertex
 - long-lived strange / charm decays or photon to e^+e^- conversions
 - “gluon splitting” into nearly collinear charm or bottom pairs

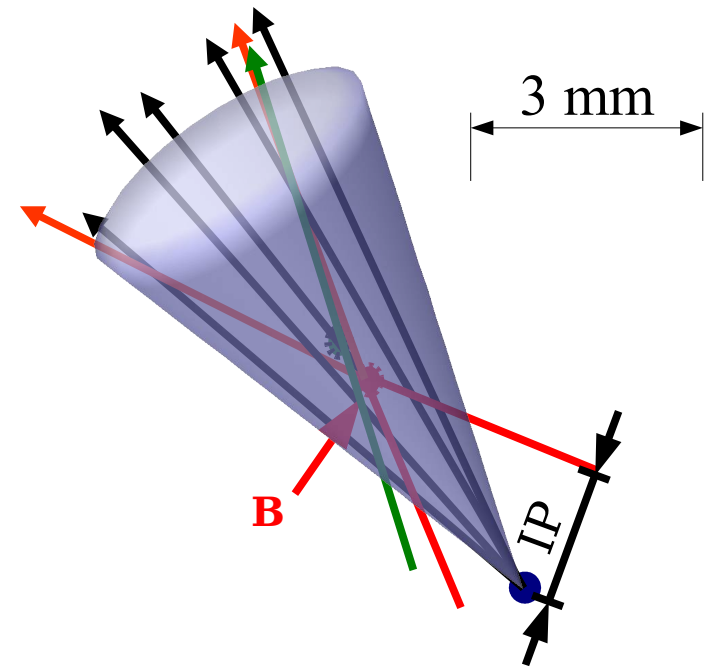

b-Tagging Efficiency

- The b-tagging efficiency is measured in data and compared to simulations
 - Very difficult because no pure b-jet data sample is available
- Use the fact that the p_{T}^{rel} spectrum of muons is different for b, c, light – jets
- Compare vertex tags to muon tags and extract vertex tagging efficiencies

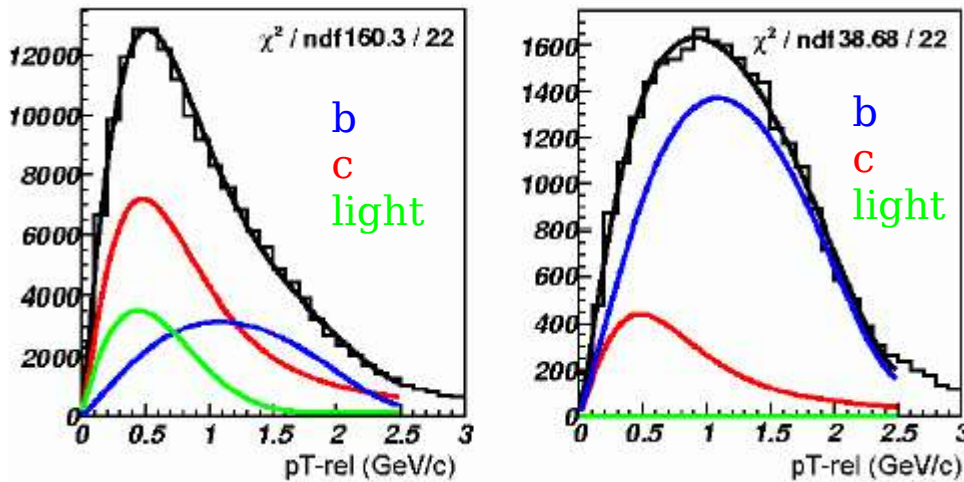
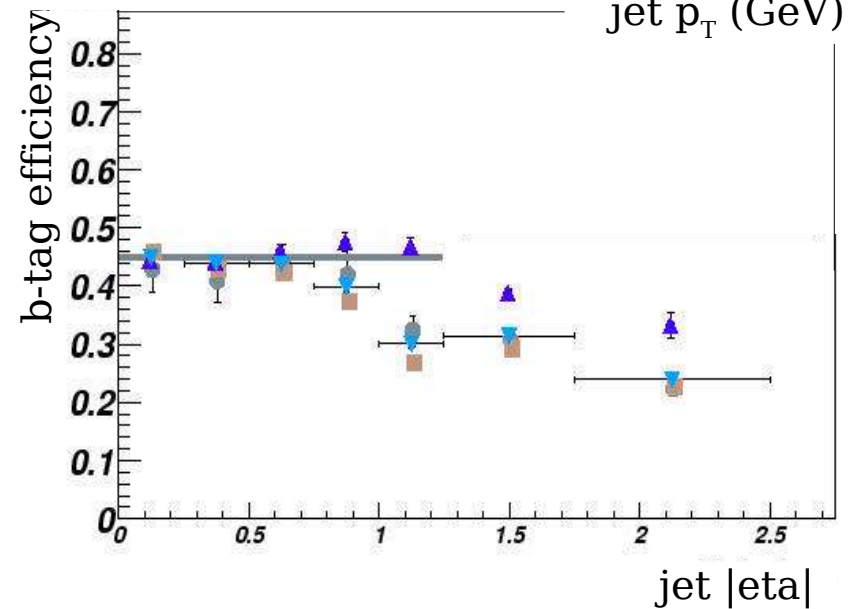
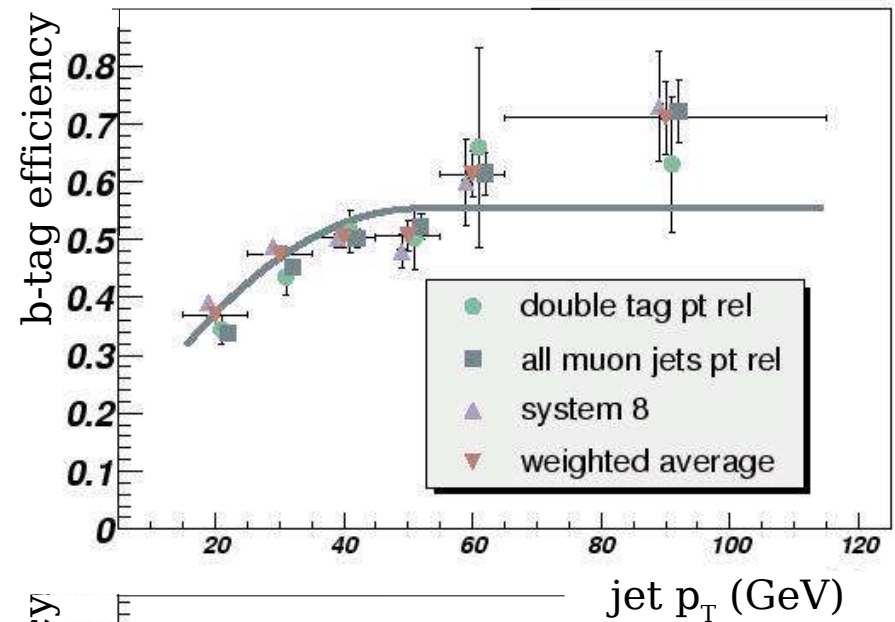

Muon P_T^{rel} spectra, before/after b-tag

Secondary Vertices in Jets

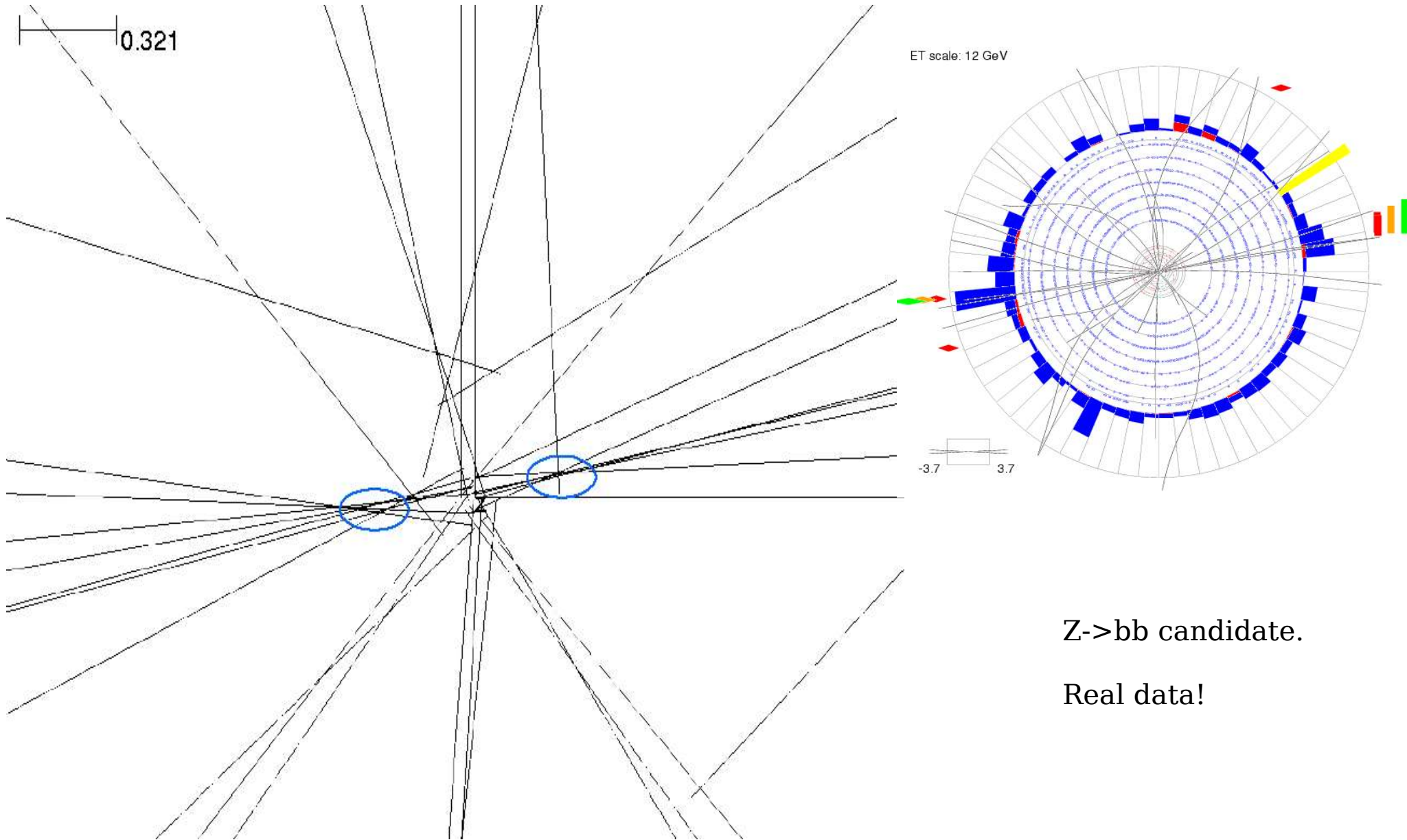

Z- \rightarrow bb candidate.

Real data!

- Signal:
 - 3 or more b-tagged jets
 - Invariant mass of leading jets is peaked at m_A
- Backgrounds:
 - Determined from data!
 - Shape estimated from the double b-tagged data sample (taking into account the kinematic bias from requiring a 3rd b-tag)
 - Normalized outside the “signal region”
 - Also modeled in MC as a cross-check
 - “fakes”: all light-quark/gluon jets (measured from data)
 - “heavy flavor”: (ALPGEN) bbj(j), ccj(j), bbcc, cccc, bbbb
 - “other”: tt, Z(\rightarrow bb)+jets (Pythia)

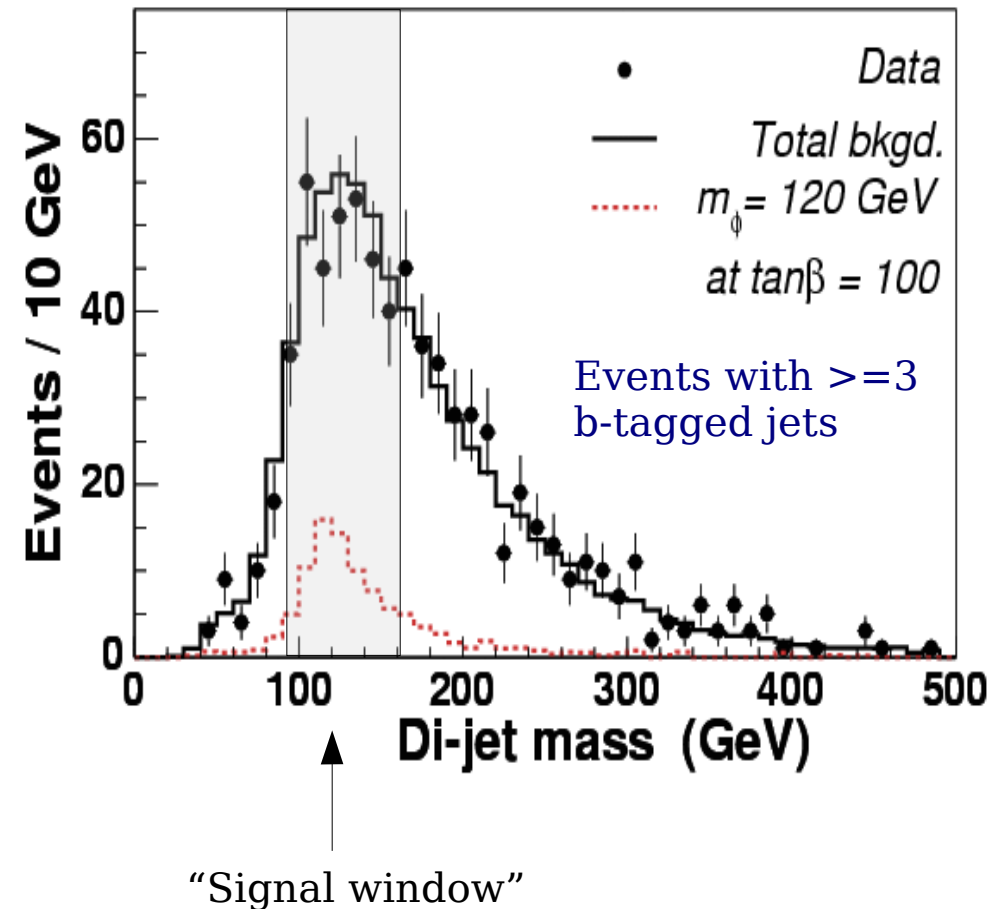

Triple b-tagged Background

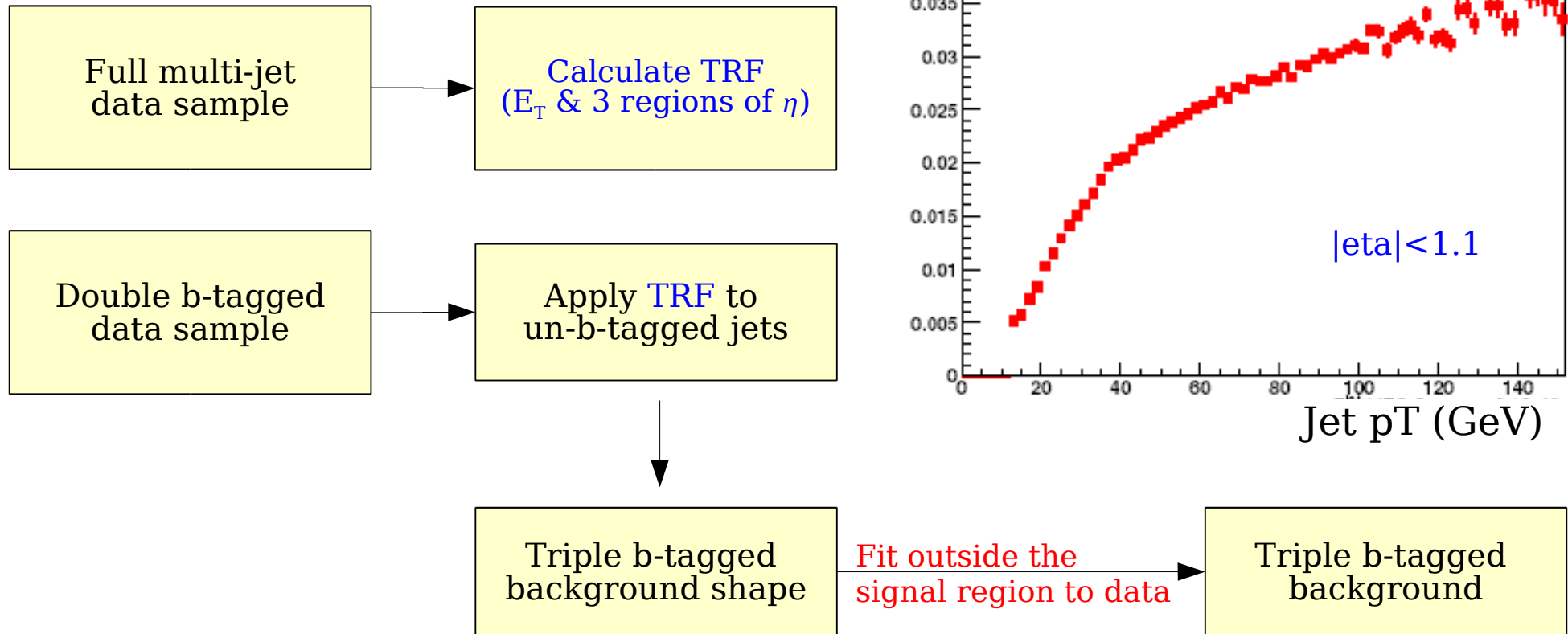

Background is completely determined from data !

Cross-check Using Double b-tagged Data

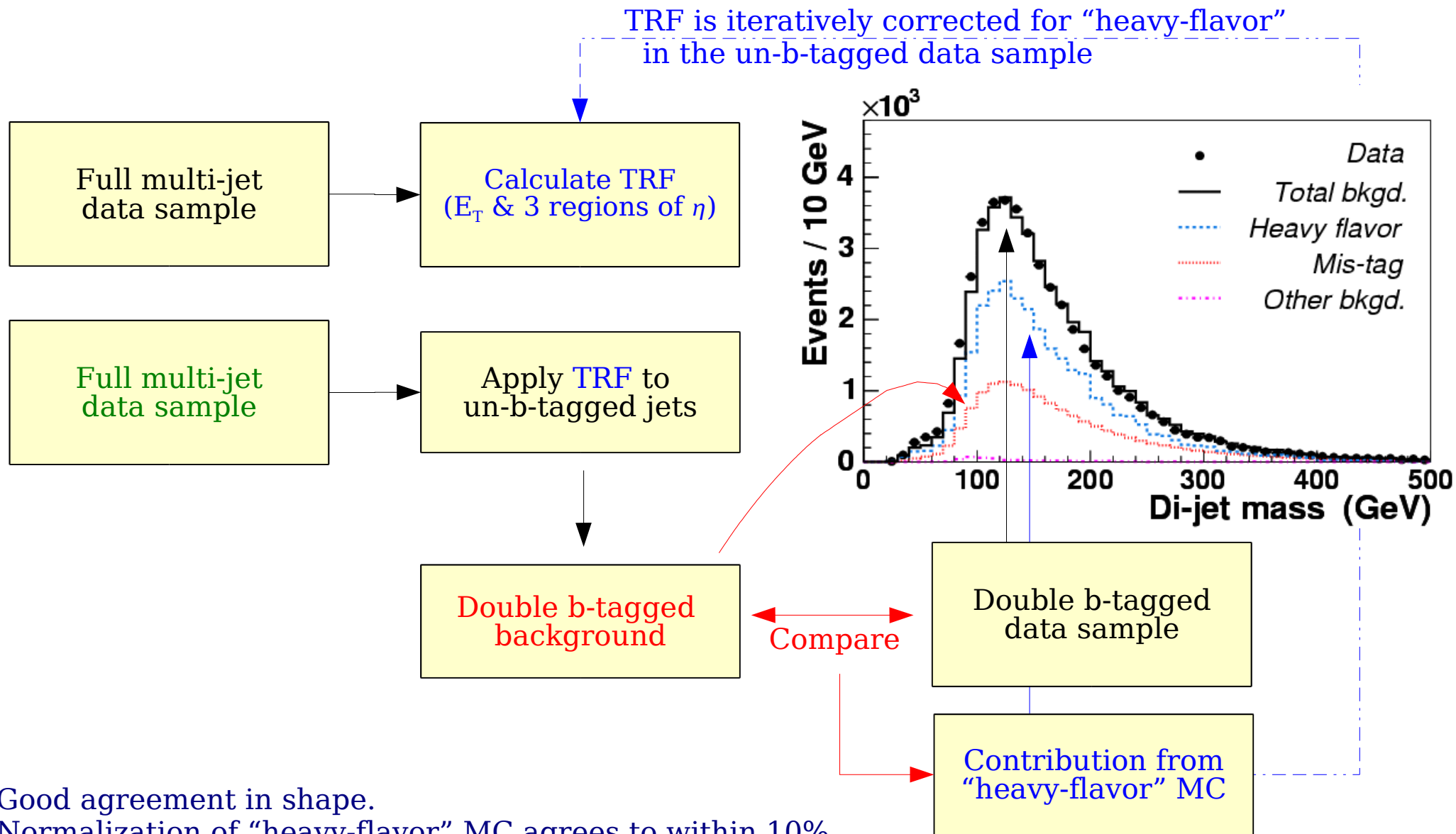

Good agreement in shape.
 Normalization of “heavy-flavor” MC agrees to within 10%.

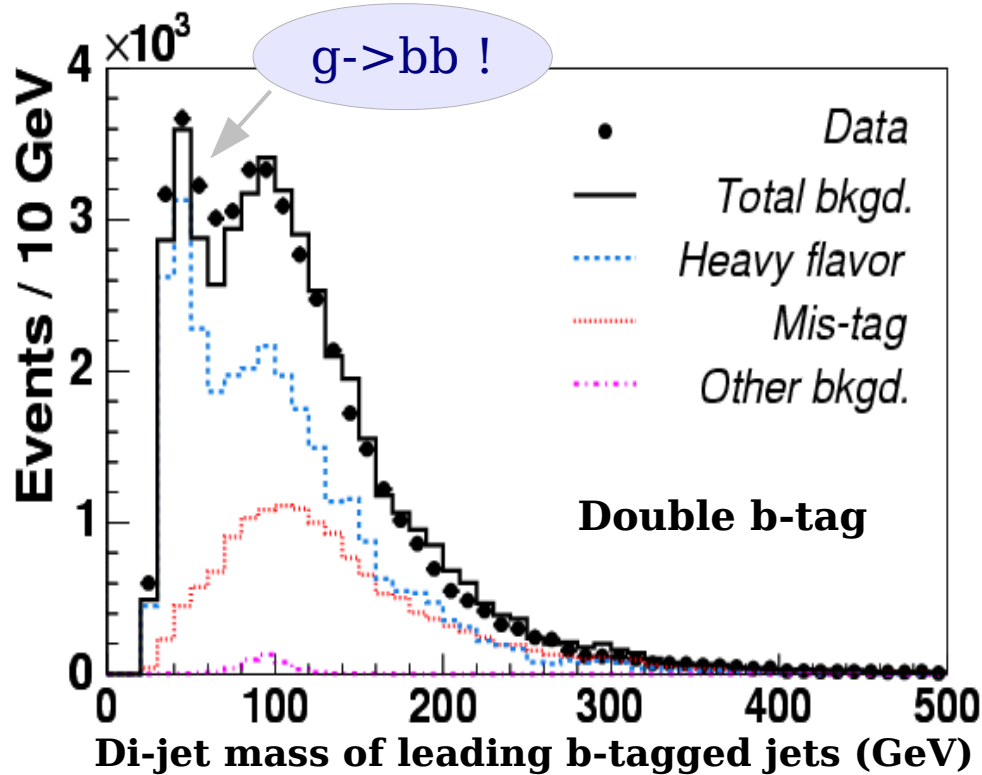

Monte Carlo accurately predicts many other distributions in the double b-tagged data as well.

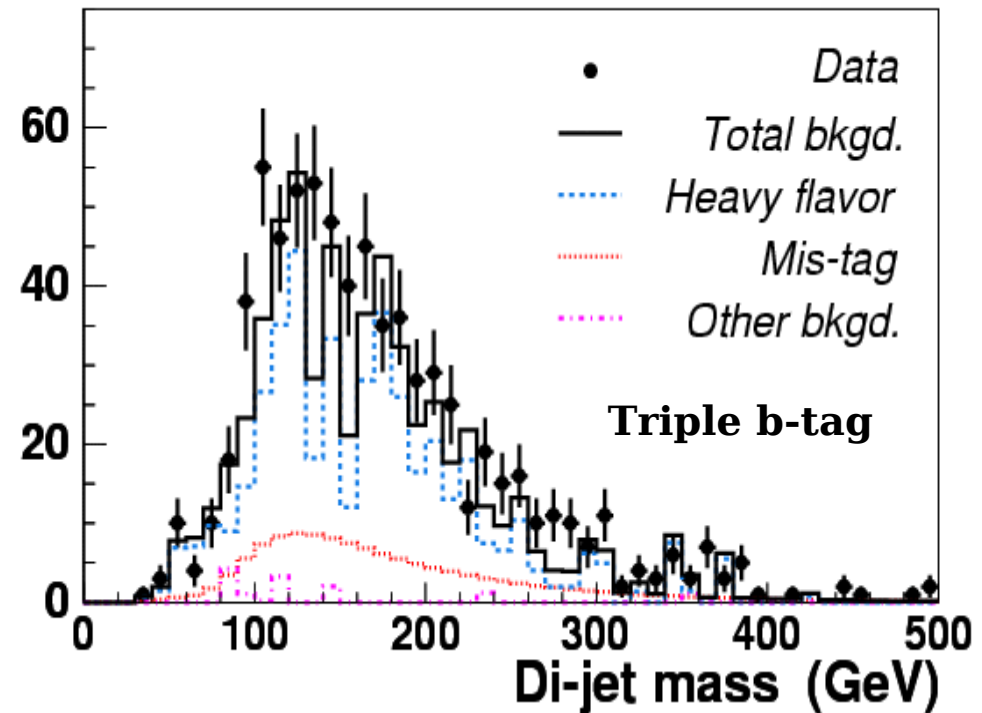

Monte Carlo predicts a background shape and normalization in good agreement with the triple b-tagged data.

Systematic Uncertainties

- Signal efficiency uncertainties

(total = 21%):

b-tagging efficiency (15%)

Trigger efficiency (9%)

Jet energy scale (8%)

Integrated luminosity (6.5%)

NLO kinematics (5%)

Jet reco/ID efficiency (4%)

Jet energy resolution (1%)

- Background shape / normalization

uncertainties (total = 3%):

TRF shape (2%)

Statistics outside signal window (1%)

Width of signal window (1%)

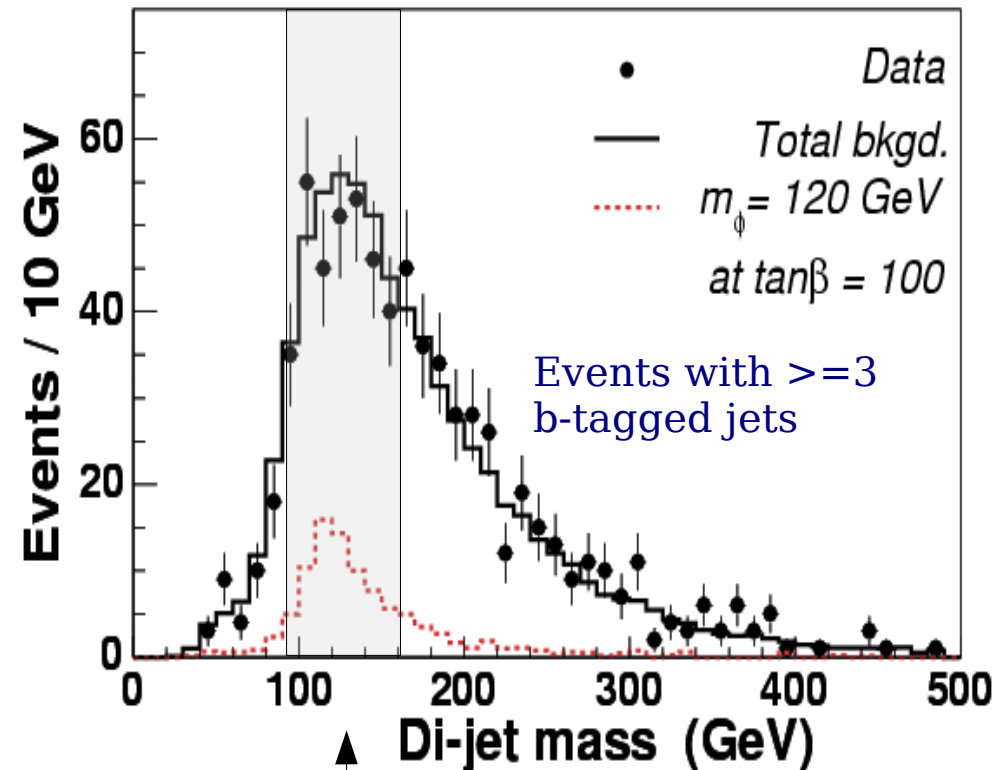

MSSM Beyond Tree-Level

- Supersymmetric loop corrections are calculated using “CPSuperH”
 - Production doesn't scale like $\tan^2\beta$... can be faster or slower depending on the supersymmetric model and its parameters
- We set limits on $\tan\beta$ vs. m_A in two of the “benchmark scenarios”:
 - **no mixing** and **maximal mixing** in the stop-quark sector

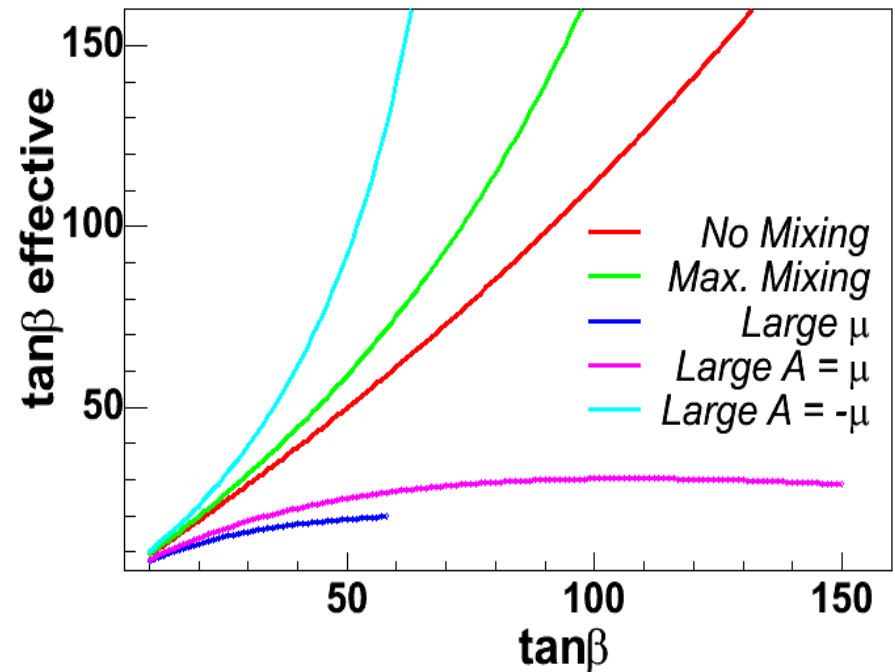

$$\sigma \times BR_{SUSY} = 2 \times \sigma_{SM} \times \frac{\tan^2\beta}{(1 + \Delta_b)^2} \times \frac{9}{[9 + (1 + \Delta_b)^2]}$$

Δ_b is a function of various SM/SUSY parameters:

$X_t = A_t - \mu \cot\beta$, μ , M_g , M_q , etc.

- Limits set using CL_s method (TLimit)
 - For each m_A , set a cross-section limit at 95% C.L.
 - We got a little lucky
- Cross-section uncertainties are calculated by varying the factorization / renormalization scales, and the PDF sets (CTEQ6)
- The current result excludes much more parameter space than our preliminary result from last year
 - Similar analysis, with more data
 - But, much more carefully done! And:
 - better reconstruction
 - vastly improved theoretical understanding

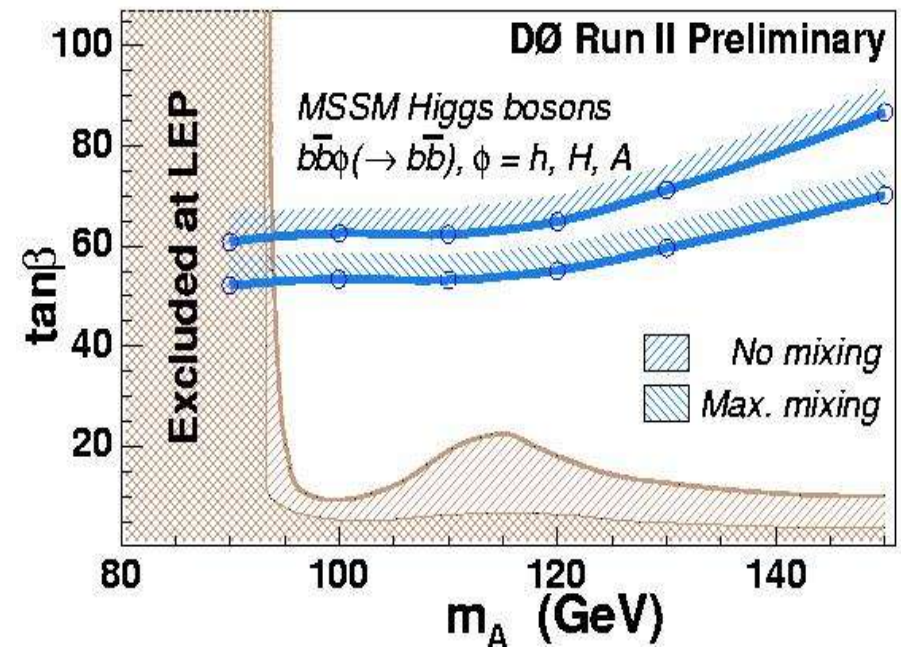
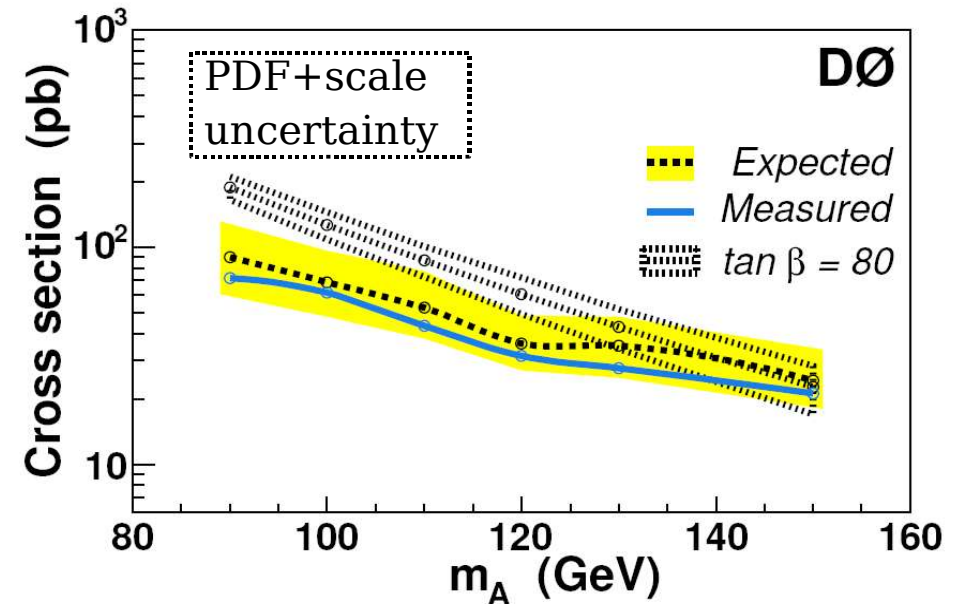

A Quadruple b-tagged Event

Run 193355 Evt 26505643 Tue May 25 14:18:18 2004

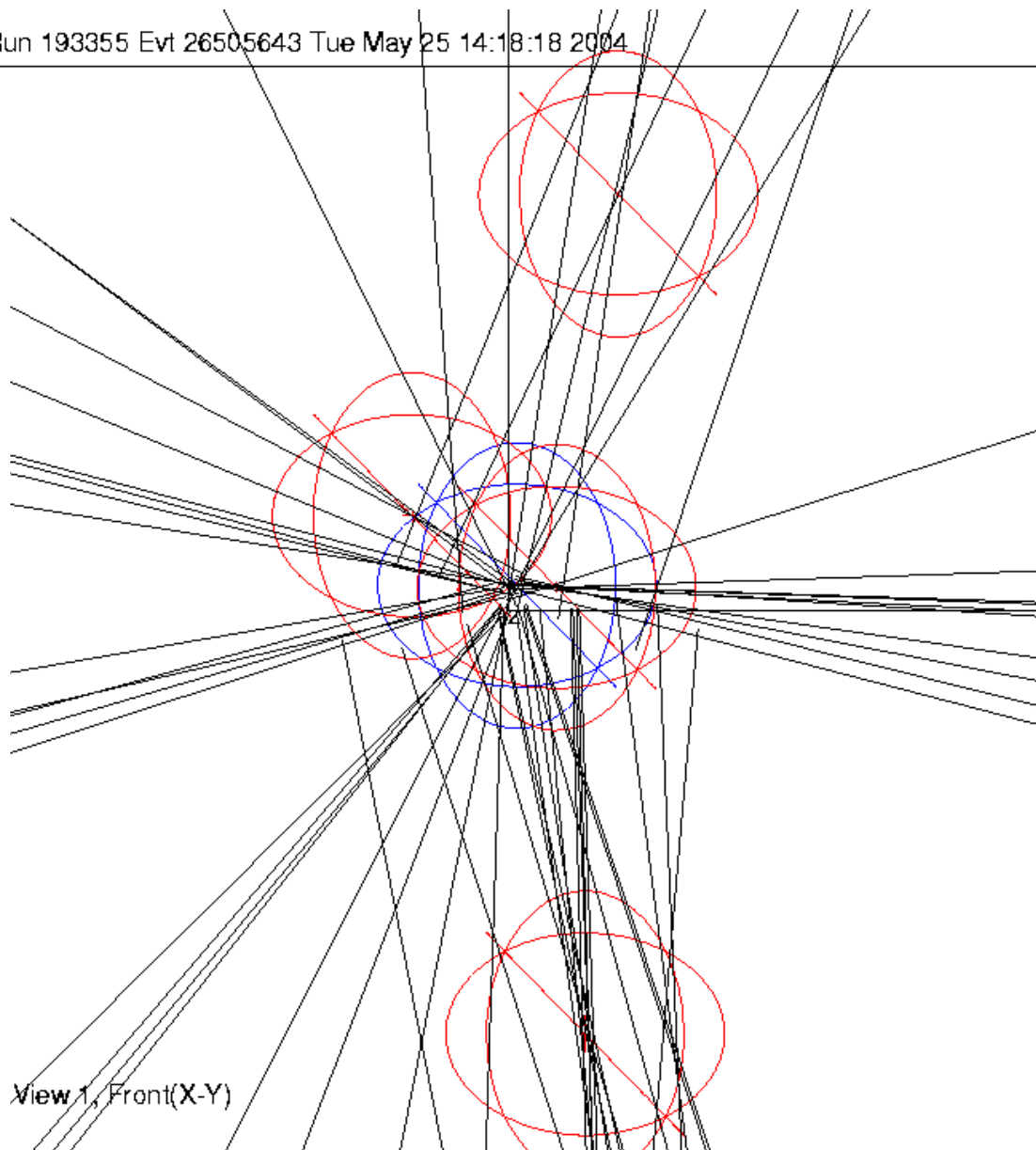

Run 193355 Evt 26505643 Tue May 25 14:18:18 2004

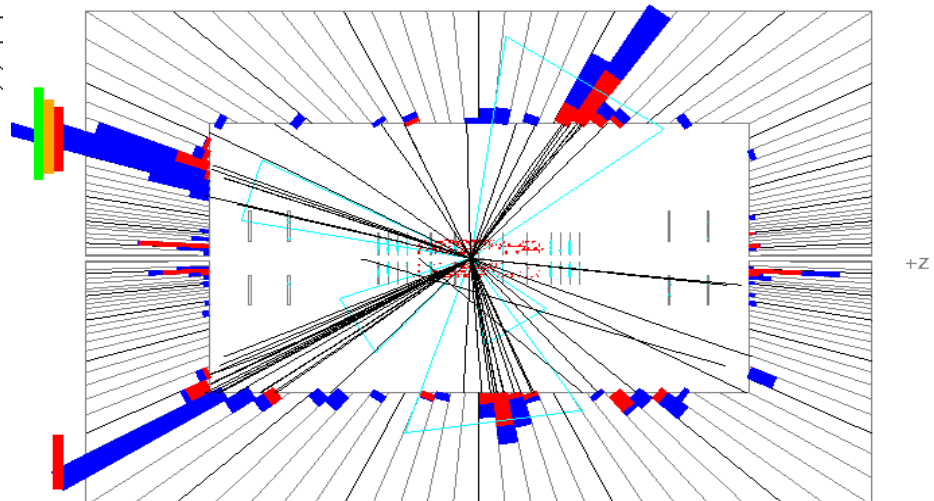
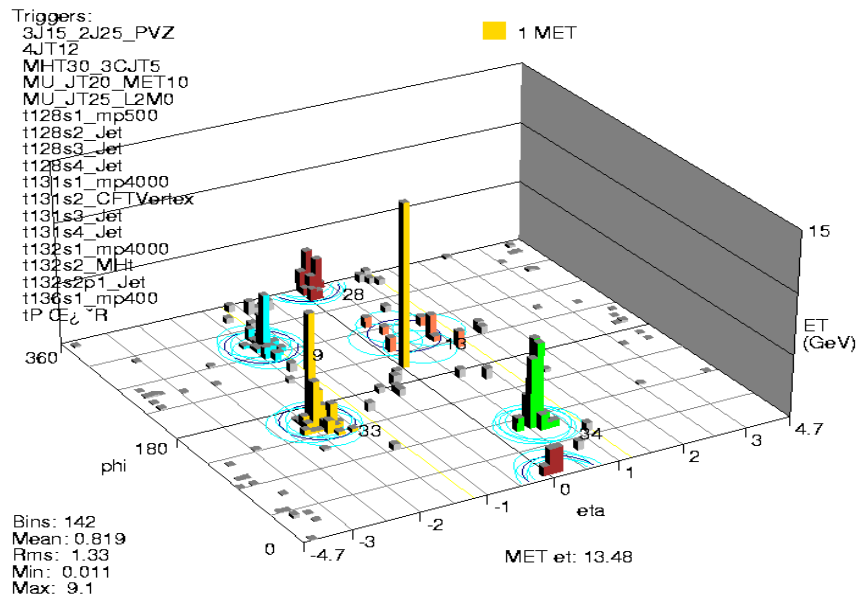

Future of the Analysis

- With no analysis improvements, expect to exclude down to $\tan\beta=40$ with 4fb^{-1}
- But we also look forward to a much improved analysis with next year's data set (1fb^{-1})
 - Inclusion of more triggers
 - Better calorimeter and jet energy calibration / resolution
 - Improved b-tagging
 - Use quadruple b-tagged events
 - Neural network?
- Combine with $bbH(\rightarrow\tau\tau)$?
- Also keeping an eye on our competitors...
 - Combine with $H(\rightarrow\tau\tau)$, $H(\rightarrow bb)$ at higher m_H ?

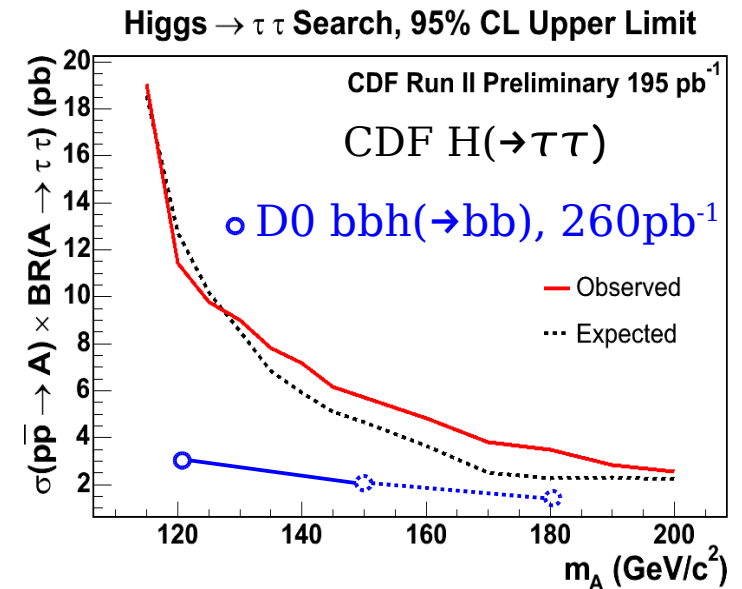
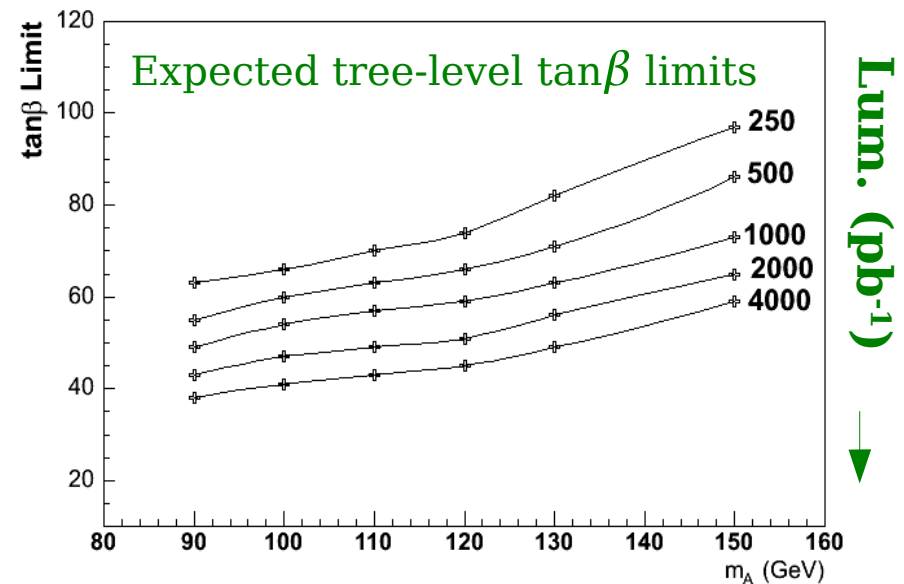

Improving the b-tagging

- This analysis is very sensitive to the b-tagging efficiency and the background tagging rate
- One obvious way to improve the b-tagging S/B is to use more information about the secondary vertex(es) in each jet
 - number of tracks on vertex
 - the χ^2
 - the “mass”
 - decay length significance
 - number of secondary vertices
 - angles between secondary vertices
 - ... combine into neural network?
- Initial studies show large gains in performance are possible

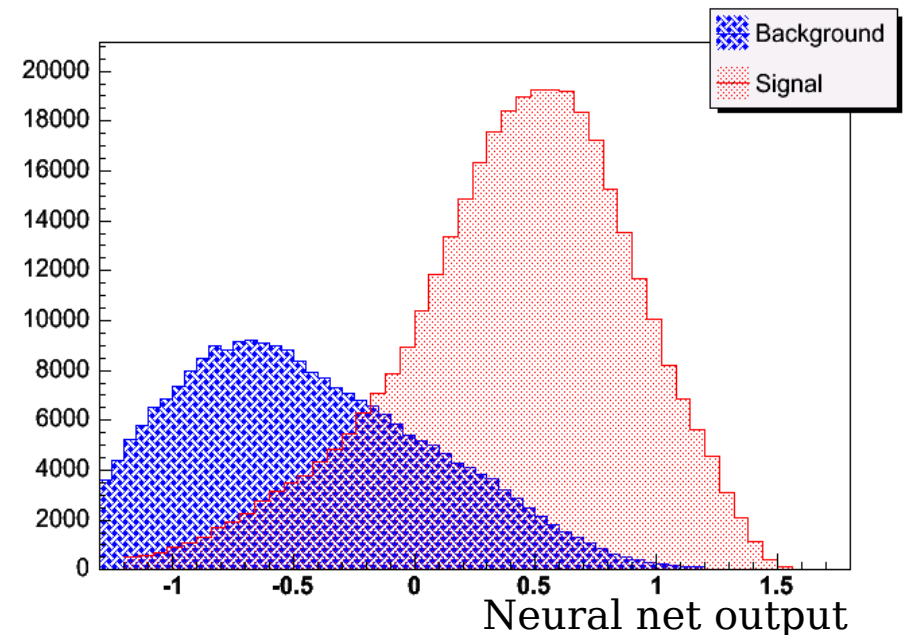
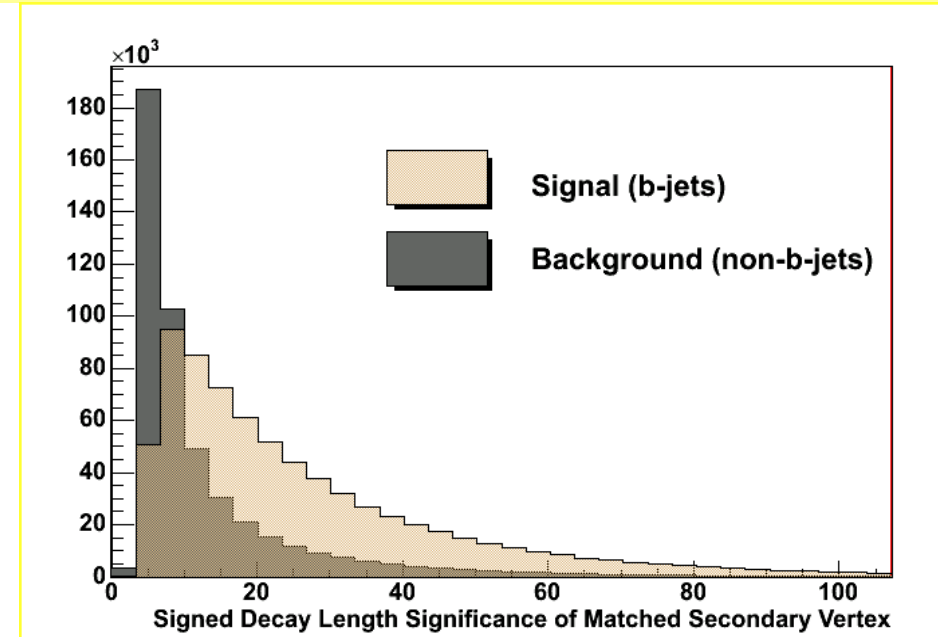

Improved Expectations

- Use of a NN for b-tagging and addition of silicon “Layer 0” for Run IIb (this fall!)
 - About a 30% improvement in b-tagging efficiency at the same background rate
- Can also decrease the systematic uncertainties by a factor of ~ 2
 - More statistics for measuring b-tagging efficiency, and better studies
 - Smaller jet energy scale uncertainty
 - More trigger studies

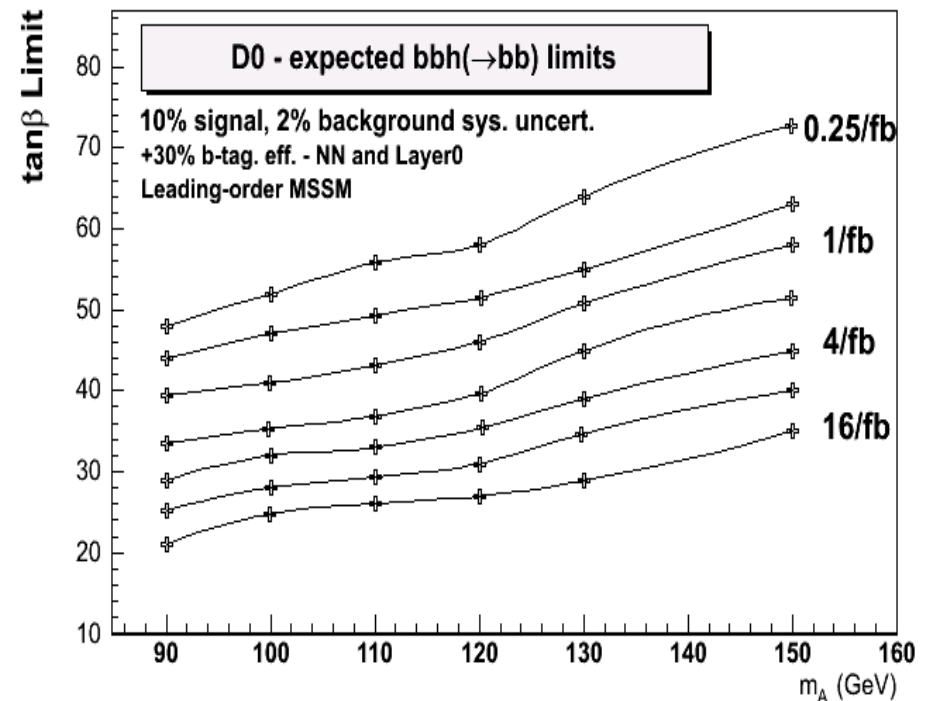

Exclude down to $\tan\beta \sim 25$
for low m_A

Exclude up to $m_A \sim 200$ GeV
for $\tan\beta > \sim 50$

Some sensitivity up to $m_A \sim 300$ GeV
for very large $\tan\beta$

- A search has been completed for neutral Higgs bosons in the MSSM using 260 pb^{-1} of DØ Run II data
 - We understand our triggers, jets, tracking, vertexing, and b-tagging
 - Good agreement between heavy-flavor multijet simulations and data
 - Methods were developed for estimating the triple b-tagged backgrounds
 - Solid theoretical understanding of the bbh production process in the MSSM
 - [hep-ex/0504018](#) : submitted to PRL!
- Now that an initial analysis has been completed, we will focus on improving it
 - Better b-tagging
 - Advanced analysis techniques
 - New triggers / data – 1 fb^{-1} by this summer, $\sim 8 \text{ fb}^{-1}$ by 2009!
- We hope to make a discovery, or place impressive limits on $\tan\beta$ vs. m_A in the next few years, while preparing for the LHC era

Backup slides...

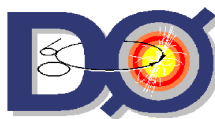

The Final Piece of the Standard Model

- The Higgs boson is needed for the Standard Model to be consistent
- Only one parameter of the Higgs is undetermined: its mass...
 - Precision measurements predict:
 $114 \text{ GeV} < m_h < 211 \text{ GeV}$
- We're looking hard for the SM Higgs at the Tevatron...

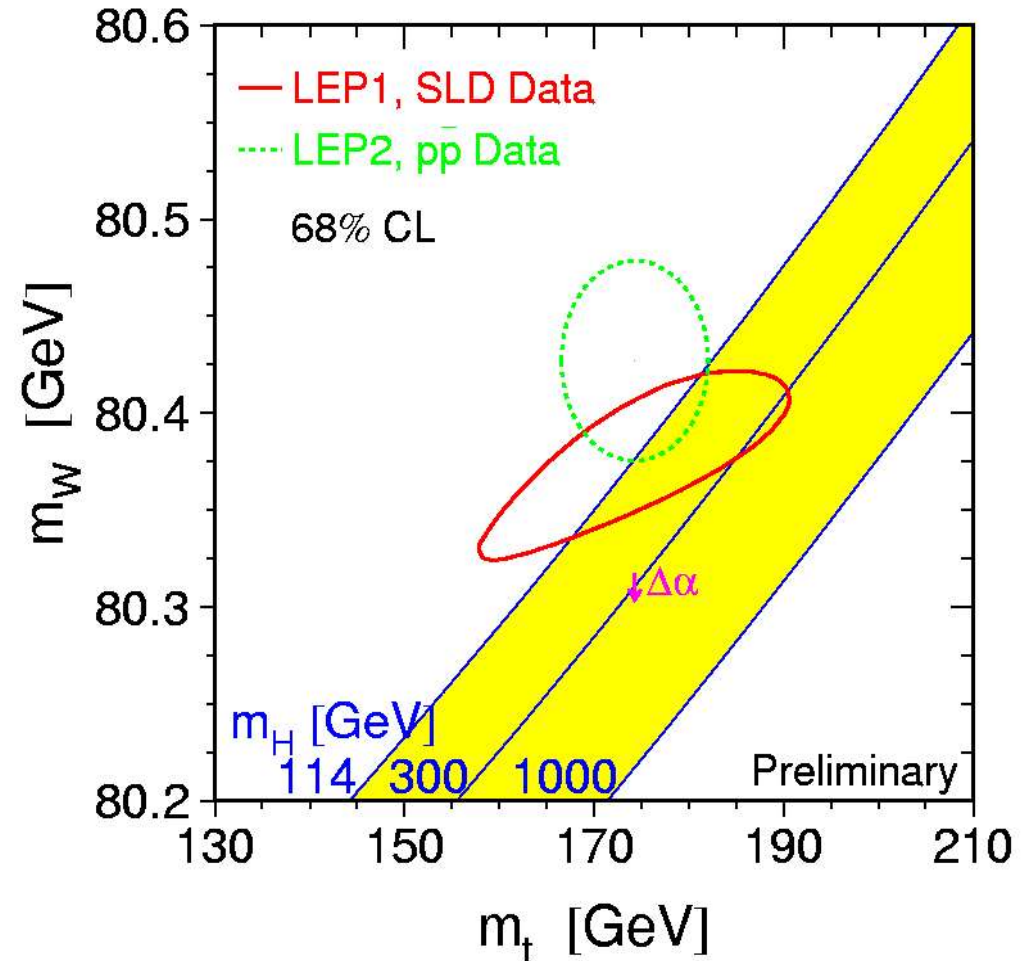

More to the Story?

- Hierarchy problem:
 - Why is $m_h \ll m_{pl}$?
- Hierarchy stability problem:
 - QFT predicts radiative corrections
 - How does m_h stay $\ll m_{pl}$?
- Can the gauge couplings unify?
 - Needed for Grand Unified Theories (GUT)
 - Ruled out in the SM !

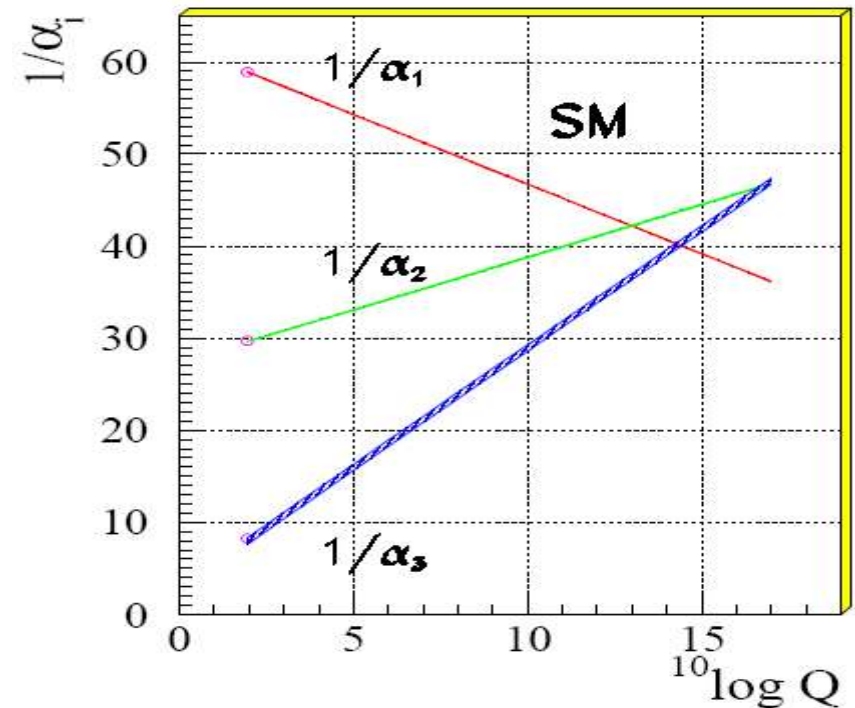
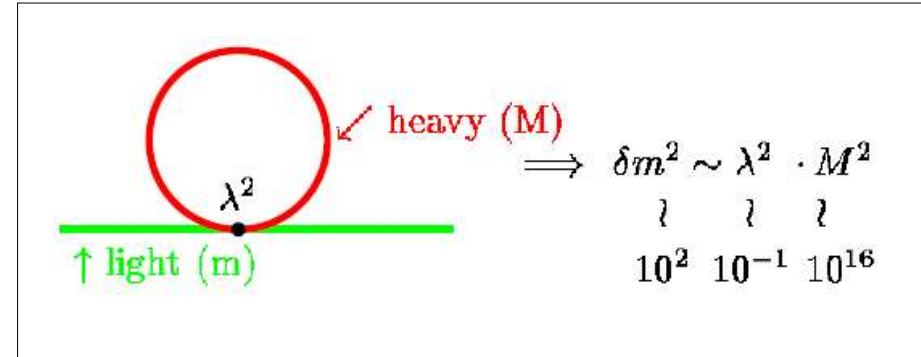

- Supersymmetry has a natural dark matter candidate: the neutralino
- $\tan\beta$ controls the annihilation rate in the early universe
- The Higgs fields could have CP-asymmetry
- Extra matter / anti-matter asymmetry of the Universe
- Dark energy is a scalar field, like the Higgs
- Supersymmetry solves the dark energy problem “halfway”...
- The inflaton is also a scalar field

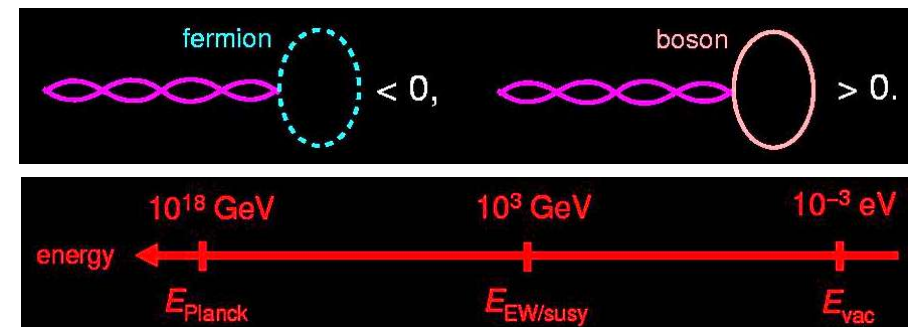
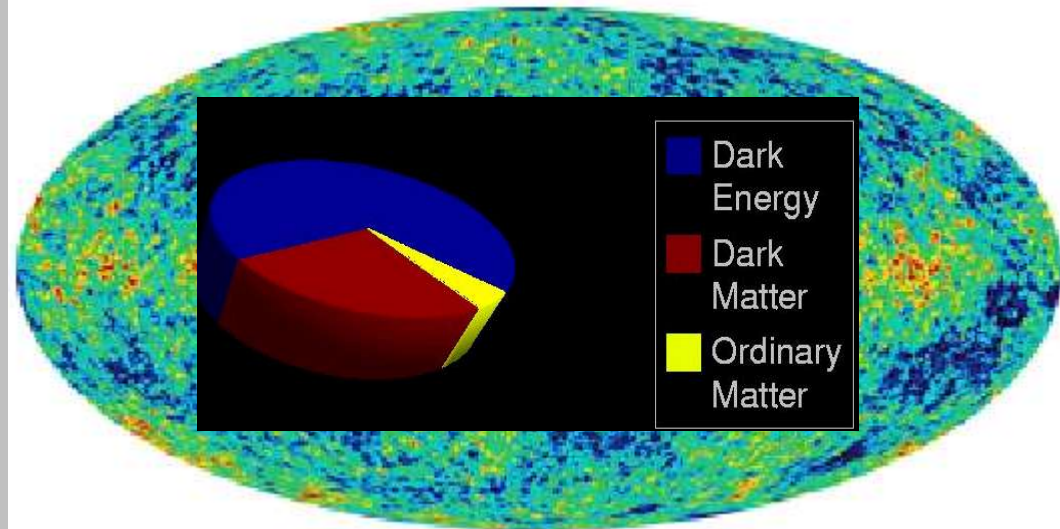

Fermilab Tevatron Accelerator – Run II

- 1 km radius p-pbar super-synchrotron
 - World's most powerful: 1.96 TeV
 - 36 bunches of p and pbar
 - 396 ns crossing period
 - 25 cm RMS interaction region
- One store every day or so...

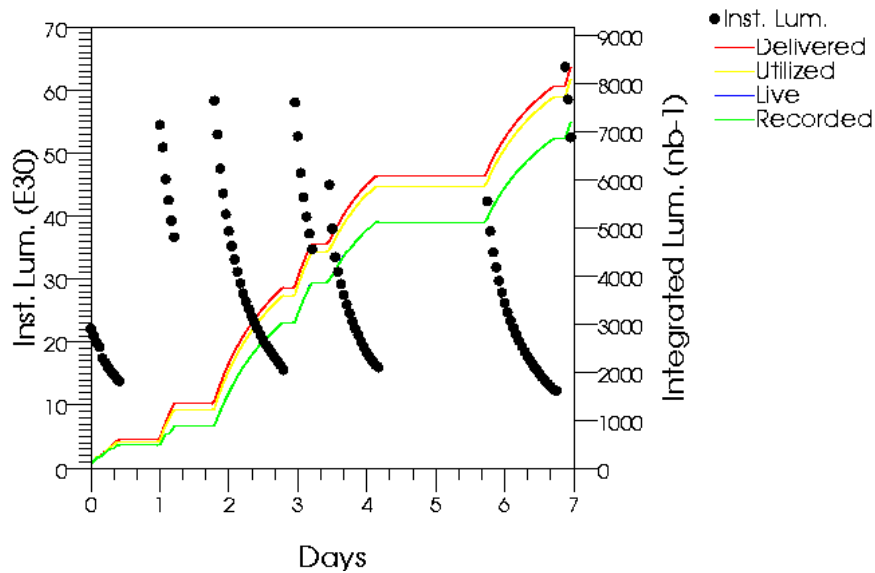
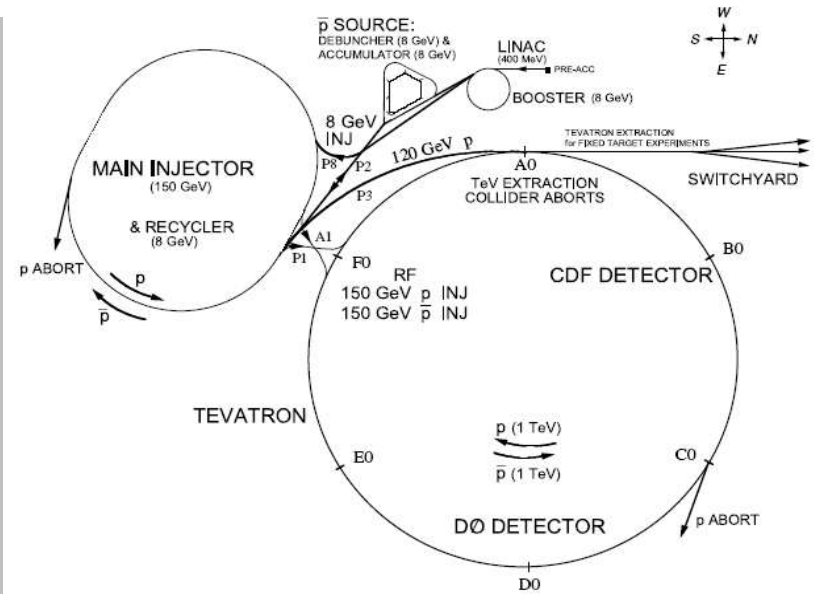

Tevatron Performance

- Run II began 4 years ago
- Instantaneous luminosity has steadily increased
- Last year was excellent, and this year is also right on track
- Almost 1 fb^{-1} delivered so far
- Should collect 4-8 fb^{-1} in the next few years

Collider Run II Peak Luminosity

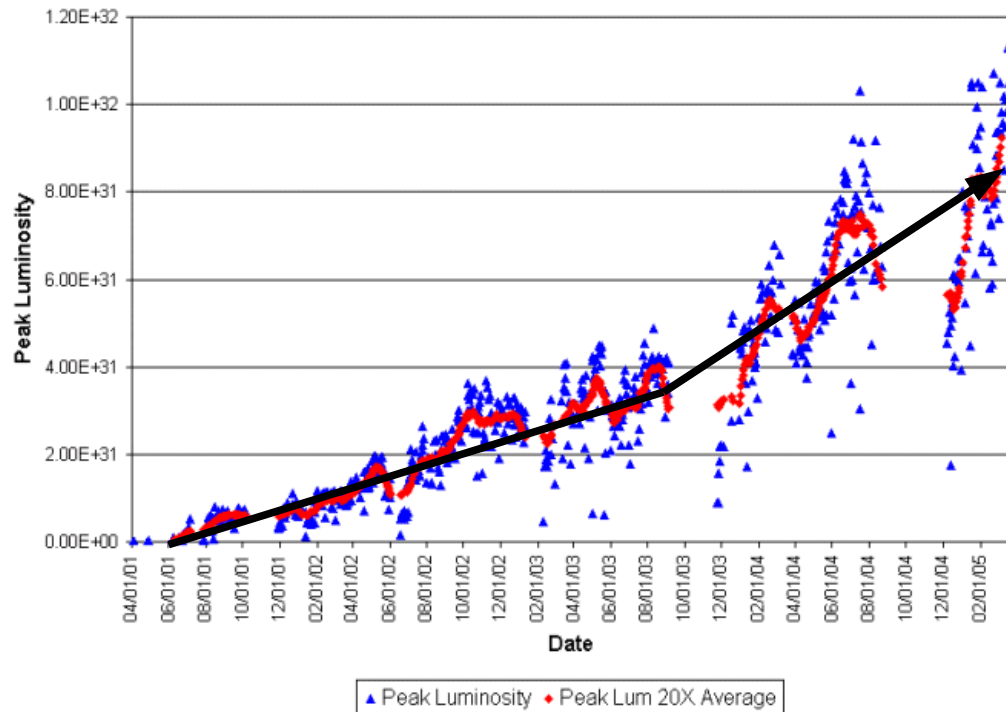

Collider Run II Integrated Luminosity

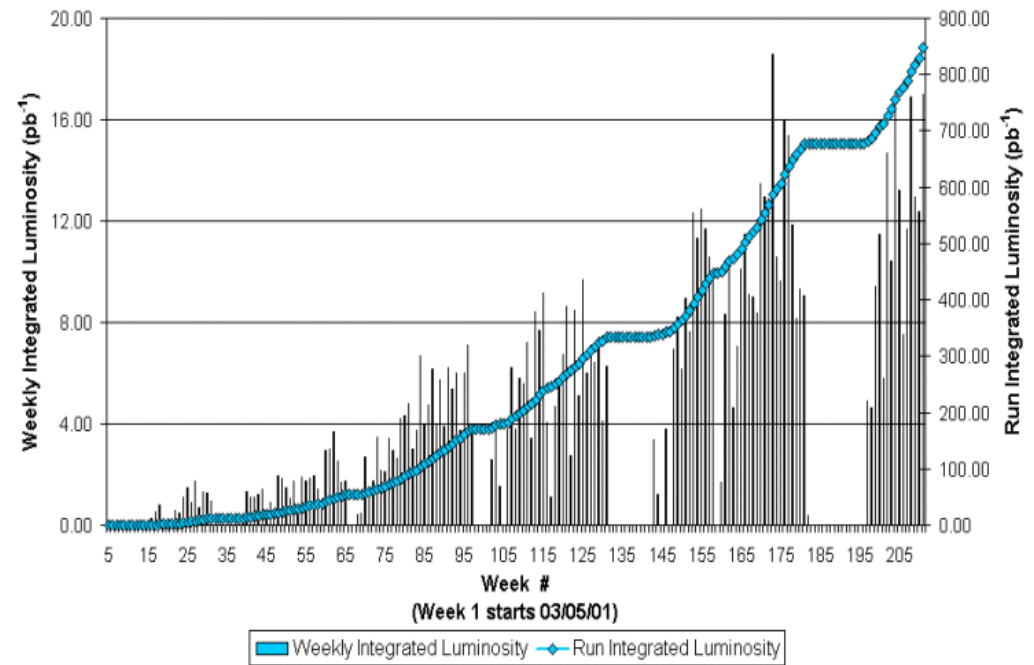

The DØ Detector for Run II

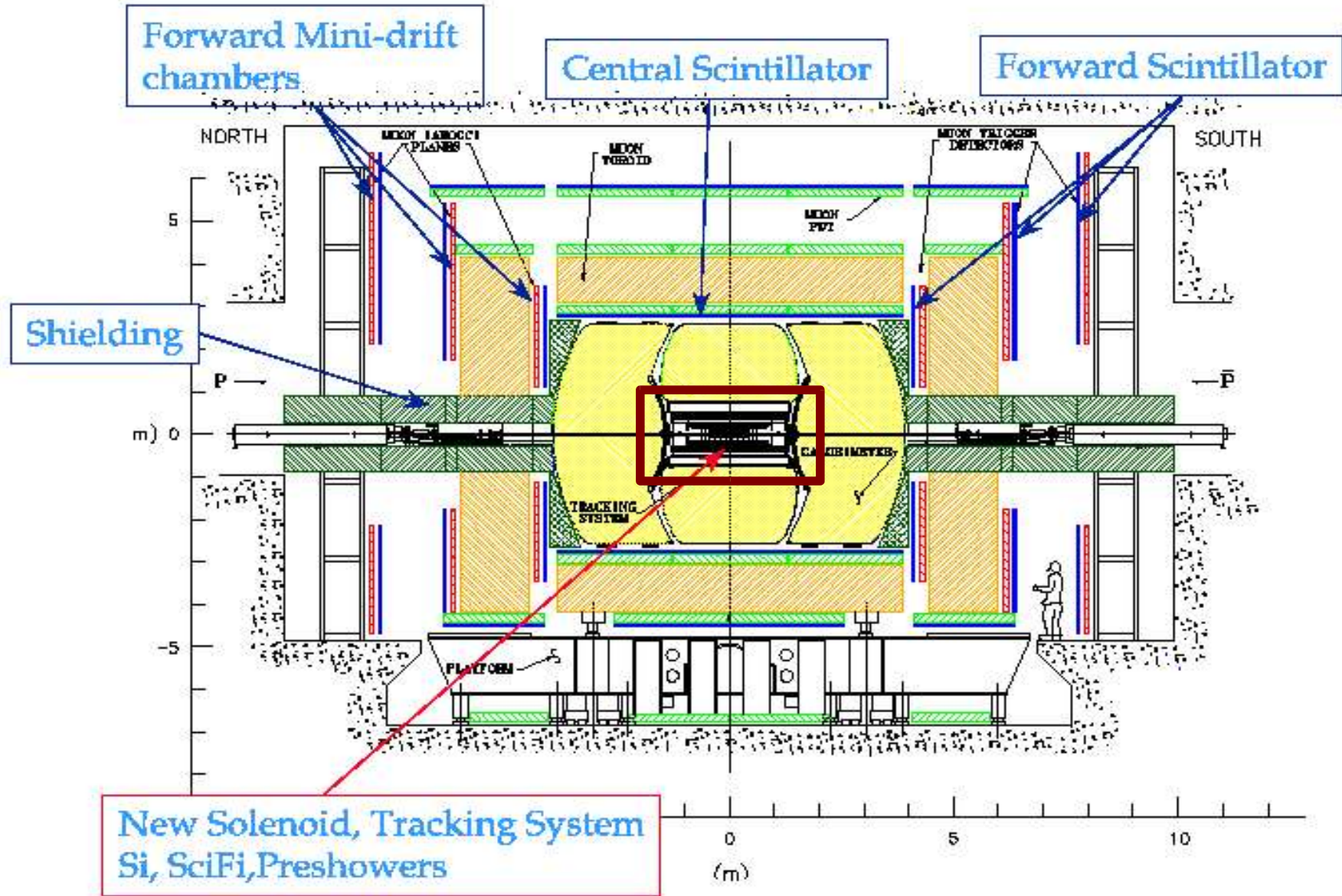

- Showers are induced by sheets of depleted Ur
- Cells measure the ionization in liquid Ar gaps
- Cells are arranged in a projective geometry
- Highly granular $(.1 \times .1)(\eta-\phi)$
- Jets are almost completely contained: >20 hadronic interaction lengths

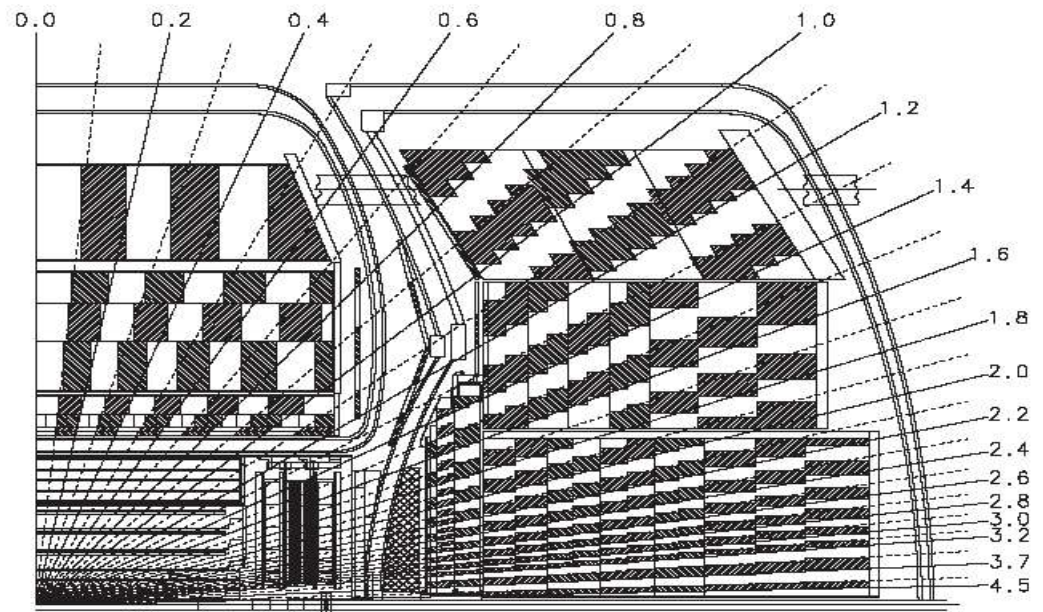
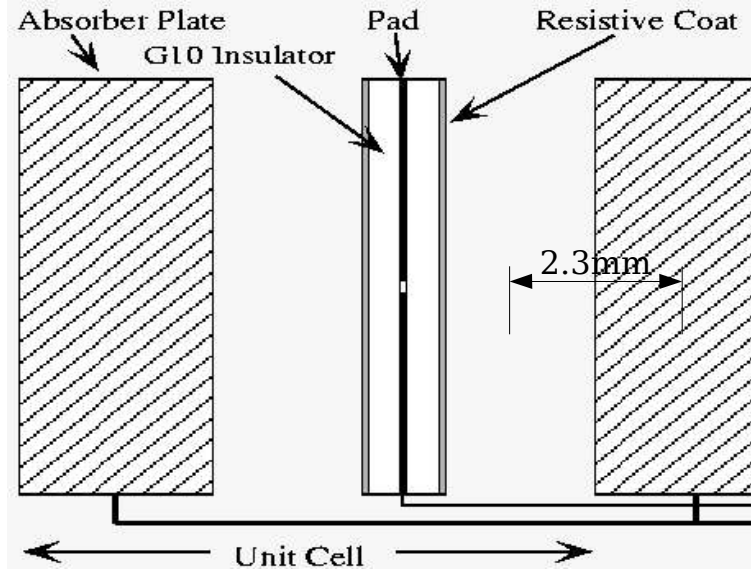

- Used in this analysis for:
 - b-tagging studies...
 - jet energy corrections
- A big toroidal Iron magnet:
~2000 Ton and 1.9 Tesla
- Only muons with $|p| > 3$ GeV penetrate the magnet
 - Very low background thanks to heavy shielding
- 3 drift-tube layers and scintillating panels determine the position and timing of muons
- Coverage out to $|\eta| < 2.0$
- A-layers and scintillators create the best muon trigger ever built

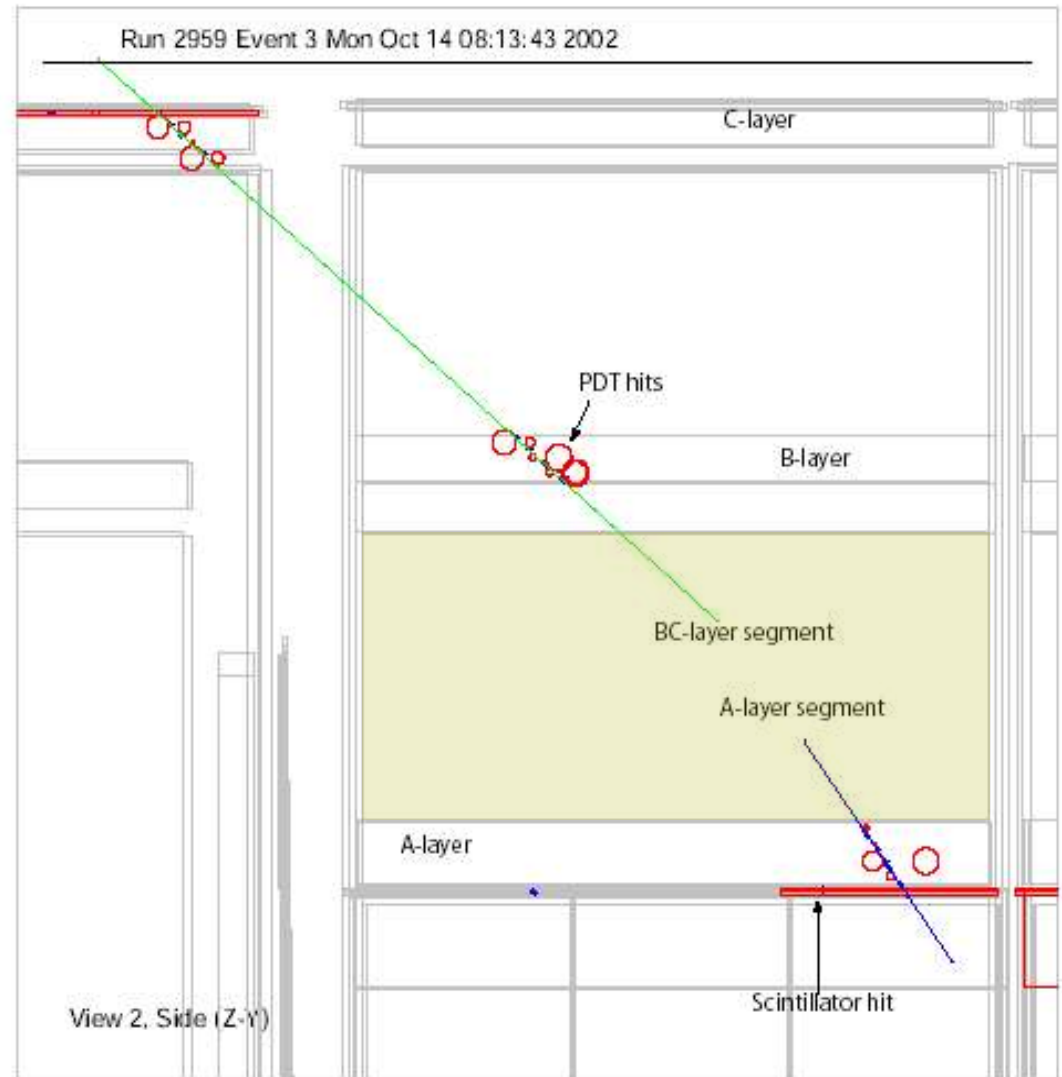

Trigger System

- Level 1

Calorimeter EM and TOT E_T ($.2 \times .2$)($\eta - \phi$)

Muon stubs

Central high- p_T axial tracks

- Level 2

Clustered calorimeter EM and TOT E_T

Missing transverse calorimeter E_T

Matched muon segments

Displaced high- p_T axial tracks

- Level 3 trigger algorithms:

Jets (no split/merge)

Central stereo tracks

Muons matched to central stereo tracks

Primary vertex

Jet lifetime b-tags

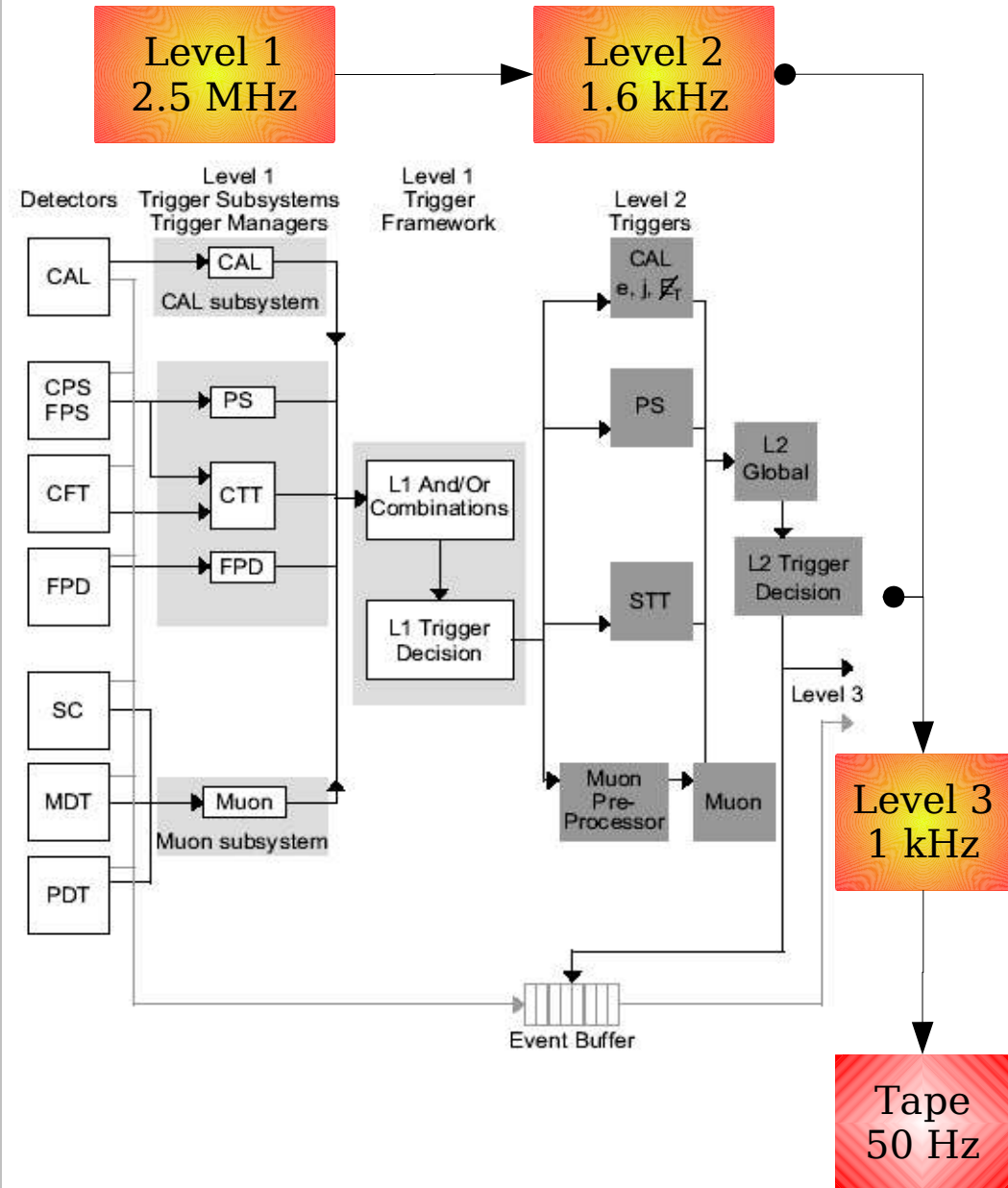

Jet Reconstruction

- The E_T in $(0.1 \times 0.1)(\eta-\phi)$ towers is summed, and seeds are found
- Energy is clustered in cones of $\Delta R = \sqrt{\Delta\eta^2 + \Delta\phi^2} = 0.5$ around the seeds
- The midpoints (in $\eta-\phi$) between stable cones are also used as seeds
- The unique cones with $E_T > 8$ GeV are merged or split, depending on whether they share more or less than 50% of a jet's E_T
- Jets' E_T are calibrated, using the jet energy scale (JES)
 - accounts for out-of-cone showering and the underlying event, on average

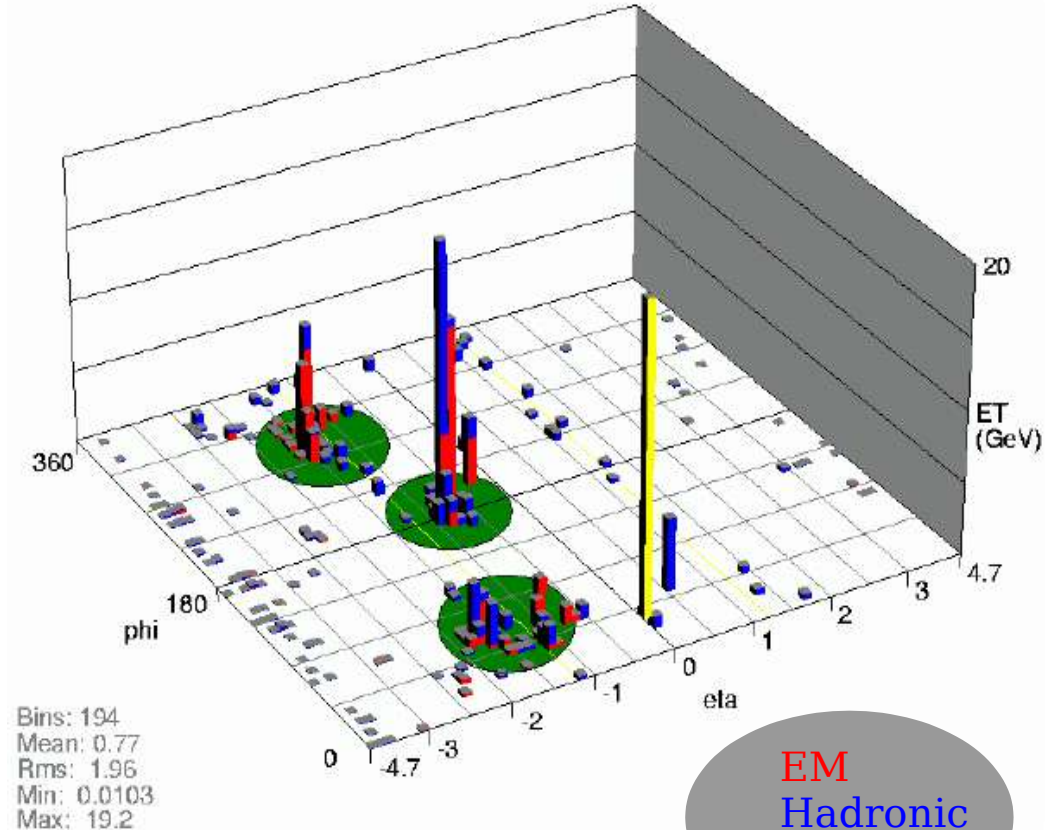

$$E_{jet}^{corrected} = \frac{E_{jet}^{colorimeter} - E_{offset}}{R_{jet} \cdot R_{cone}}$$