



The LCG File Catalog (LFC)

Jean-Philippe Baud – Sophie Lemaitre
IT-GD, CERN

May 2005





Overview



- **LFC Architecture**
- LFC/Fireman Tests
- LFC Deployment



LCG File Catalog



- Based on lessons learned in DC's (2004)
 - Fixes performance and scalability problems seen in EDG Catalogs
 - Cursors for large queries
 - Timeouts and retries from the client
 - Provides more features than the EDG Catalogs
 - User exposed transaction API
 - Hierarchical namespace and namespace operations
 - Integrated GSI Authentication + Authorization
 - Access Control Lists (Unix Permissions and POSIX ACLs)
 - Checksums



LCG File Catalog



- Based on existing code base
 - Supports Oracle and MySQL database backends
- Aim is to enable rapid development and deployment
 - Integration with GFAL and lcg_util complete
 - Performance and Scalability testing done (up to 40 millions entries)
 - First version deployed for Certification – October 2004
 - Pre-production service running at CERN – December 2004
 - Migration of entries from EDG catalog to LFC done - January 2005
 - In pre-production at DESY/HG-01-GRNET/LIP/Bari/Pisa
 - POOL Integration will be provided – May 2005



LCG File Catalog Schema

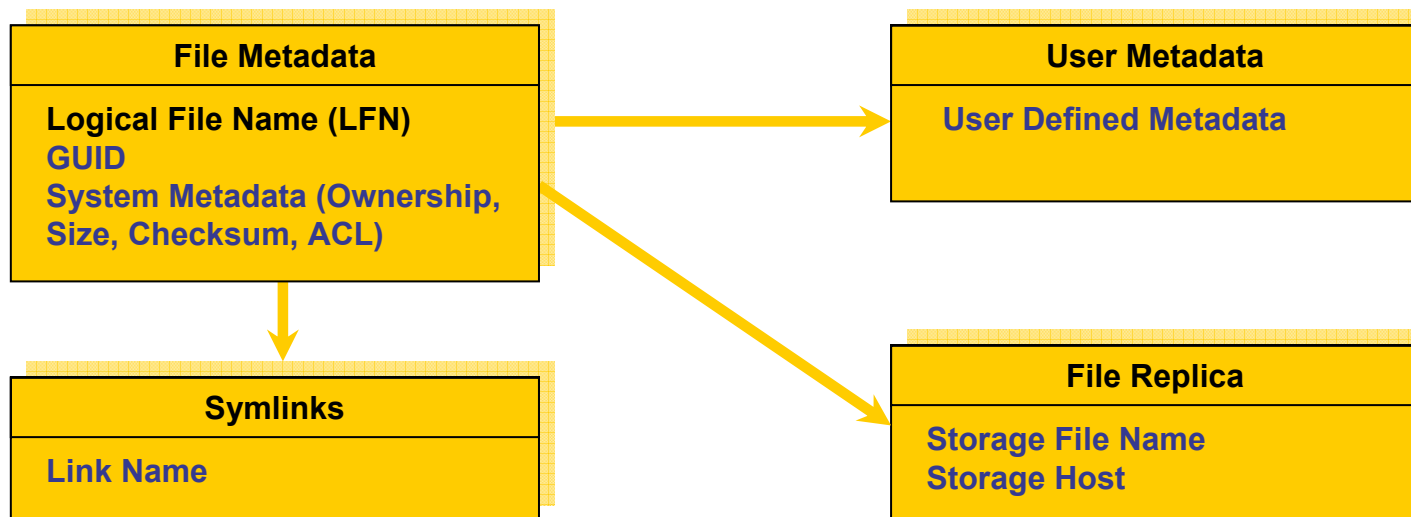

- LFN acts as main key in Database. Has:
 - Unique Identifier (GUID)
 - Information on Physical Replicas
 - Symbolic Links to it
 - A small amount (one field) of user attached metadata



Relationships in the Catalog

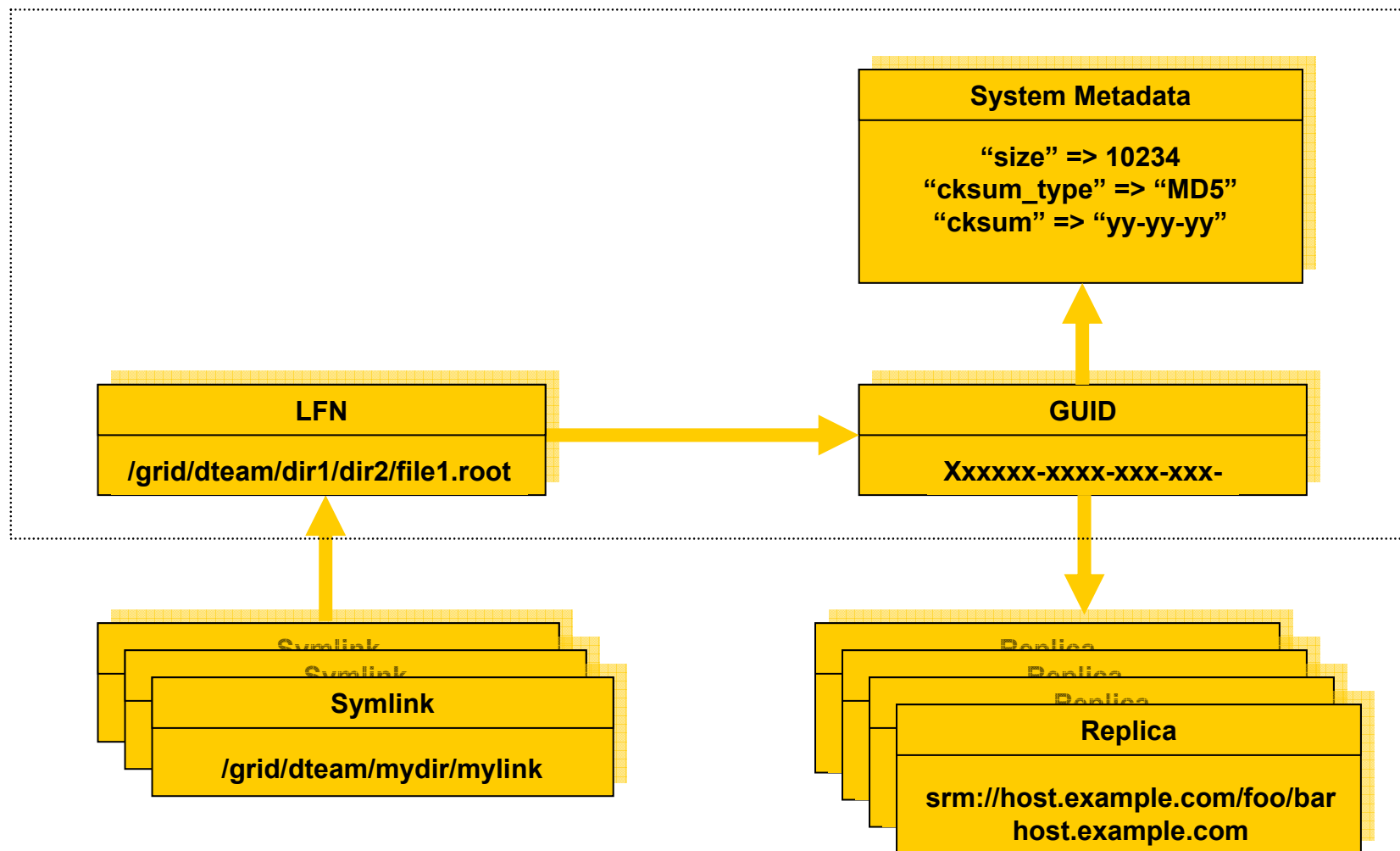



Features (1/2)



- Namespace operations
 - All names are in a hierarchical namespace
 - mkdir(), opendir(), etc...
 - Also chdir()
 - GUID attached to every directory and file
- Security – GSI Authentication and Authorization
 - Mapping done from Client DN to uid/gid pair
 - Authorization done in terms of uid/gid
 - VOMS will be integrated (collaboration with INFN/NIKHEF)
 - VOMS roles appear as a list of gids
 - Ownership of files is stored in catalog
 - Permissions implemented
 - Unix (user, group, all) permissions
 - POSIX ACLs (group and users)



Features (2/2)



- Transactions
 - Exposed to user
 - starttrans(), endtrans(), aborttrans() methods
 - Auto-rollback on failure of mutating method call
- Cursors for queries
 - Modelled on opendir()/readdir()/closedir()
- Retries and timeouts
 - Make client resilient to temporary outage of server



Layered Data Management APIs



Experiment Framework

User Tools

lcg_utils

Data Management (Replication, Indexing, Querying)

GFAL

Cataloging

Storage

Data transfer

Vendor Specific APIs

EDG

LFC

SRM

Classic SE

gridftp

Robust Data Transfer



LFC interfaces

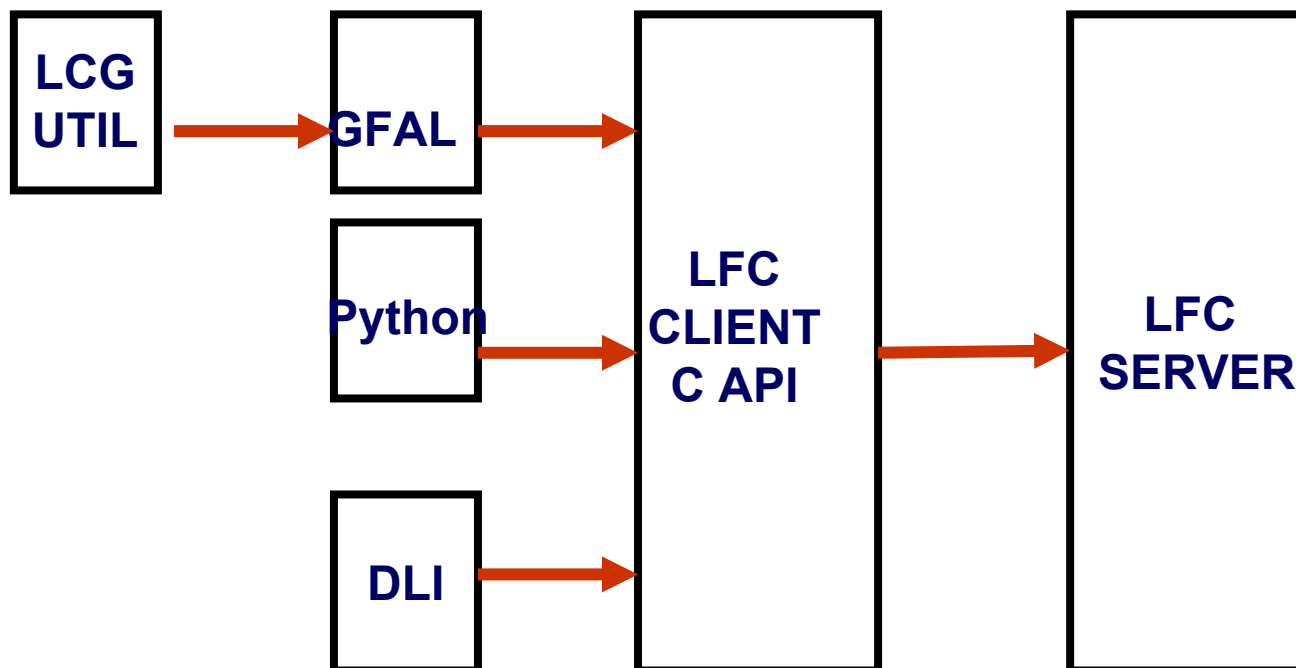



Interfaces



- GFAL is the common catalog interface used by the replication tools (lcg_util)
- DLI is the common catalog interface used by the Workload Management System
 - It is a web service interface
 - It has been used by CMS for PubDb/RefDb
 - A DLI interface to LFC is being tested



Implementation



- Server and clients are implemented in C
- Database backend: Oracle or MySQL
- Oracle interface uses ProC
- No catalogued procedure
 - Easier to port to a different DB backend
 - DB queries are very simple (key access)



Overview



- LFC Architecture
- **LFC/Fireman Tests**
- LFC Deployment



LFC Performance (i) - Inserts



- Mean insert time as number of entries increased up to 40M remains below 30 ms
- EDG mean insert time was ~40 ms with 500,000 entries
- Insert rate, with increasing number of client threads, for ~1M entries
- Increases up to ~200 adds/sec up to server thread limit
- Globus RLS gave ~84 adds/sec when run with consistency

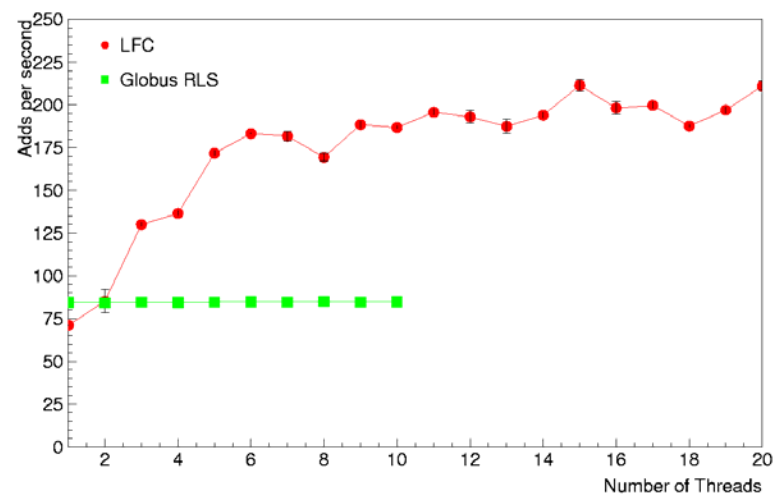
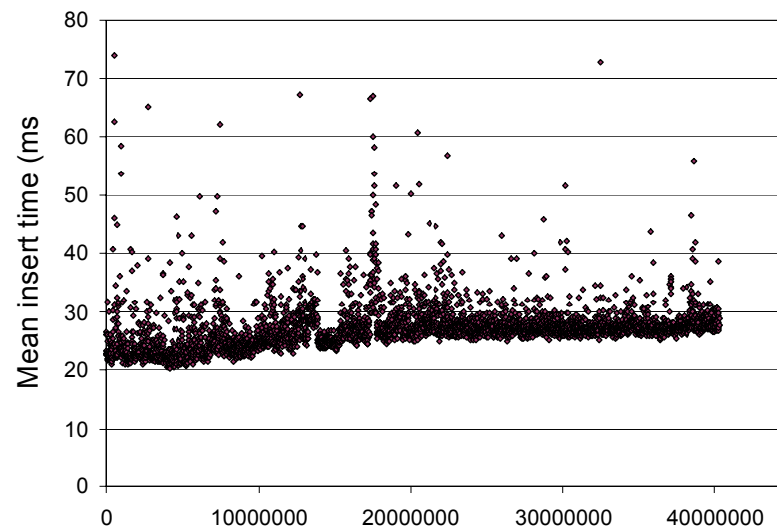



LFC Performance (ii) - Queries



- Time to list and stat all replicas of a file proportional to number of replicas
- Time to read a directory is directly proportional to

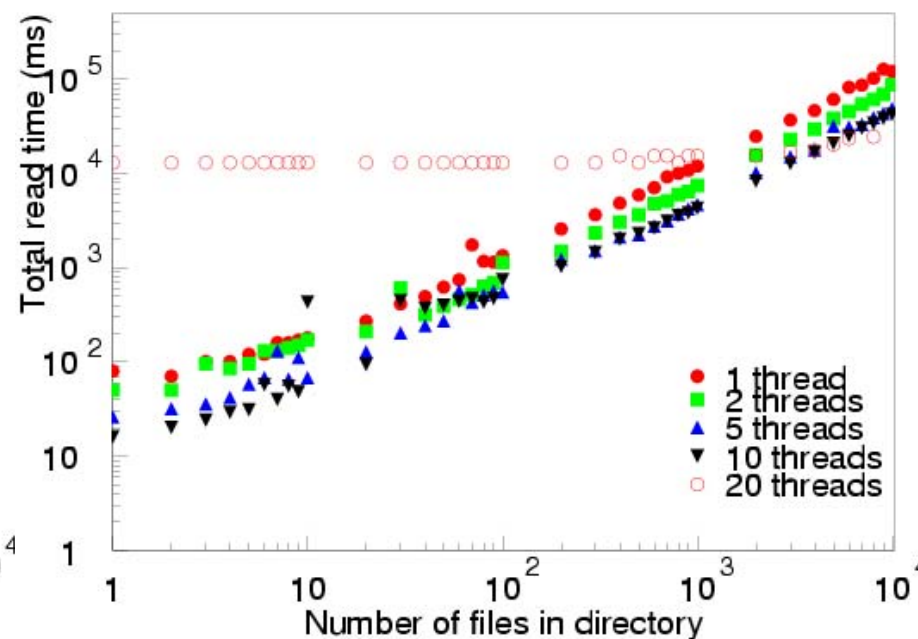
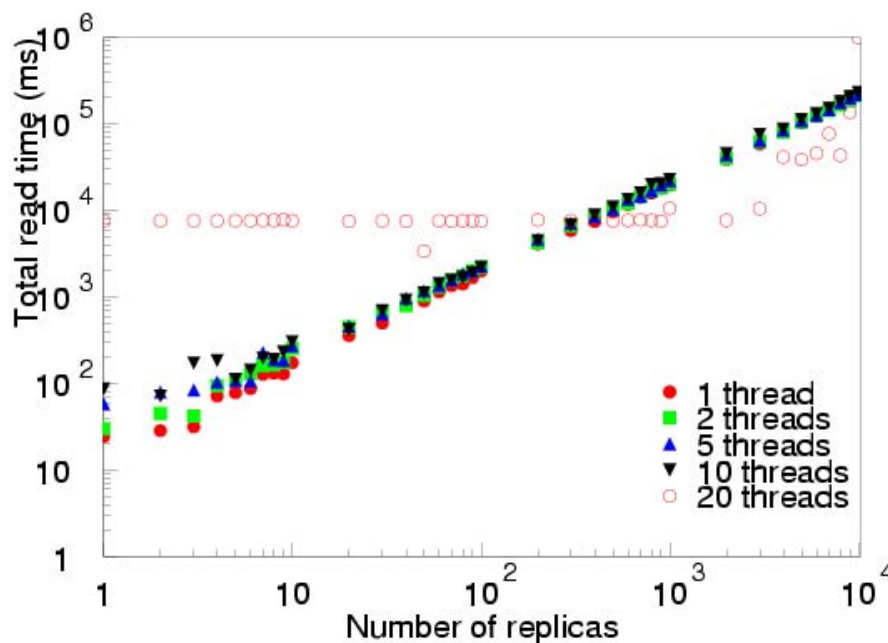



LFC Tests Summary



- LFC has been tested and shown to be scalable to at least:
 - 40 million entries
 - 100 client threads
- Performance improved with comparison to RLSs
- Stable :
 - Continuous running at high load for extended periods of time with no crashes
 - Based on code which has been in production for > 4 years
- Tuning required to improve bulk performance



FiReMan Performance - Insert



- Comparison with LFC:

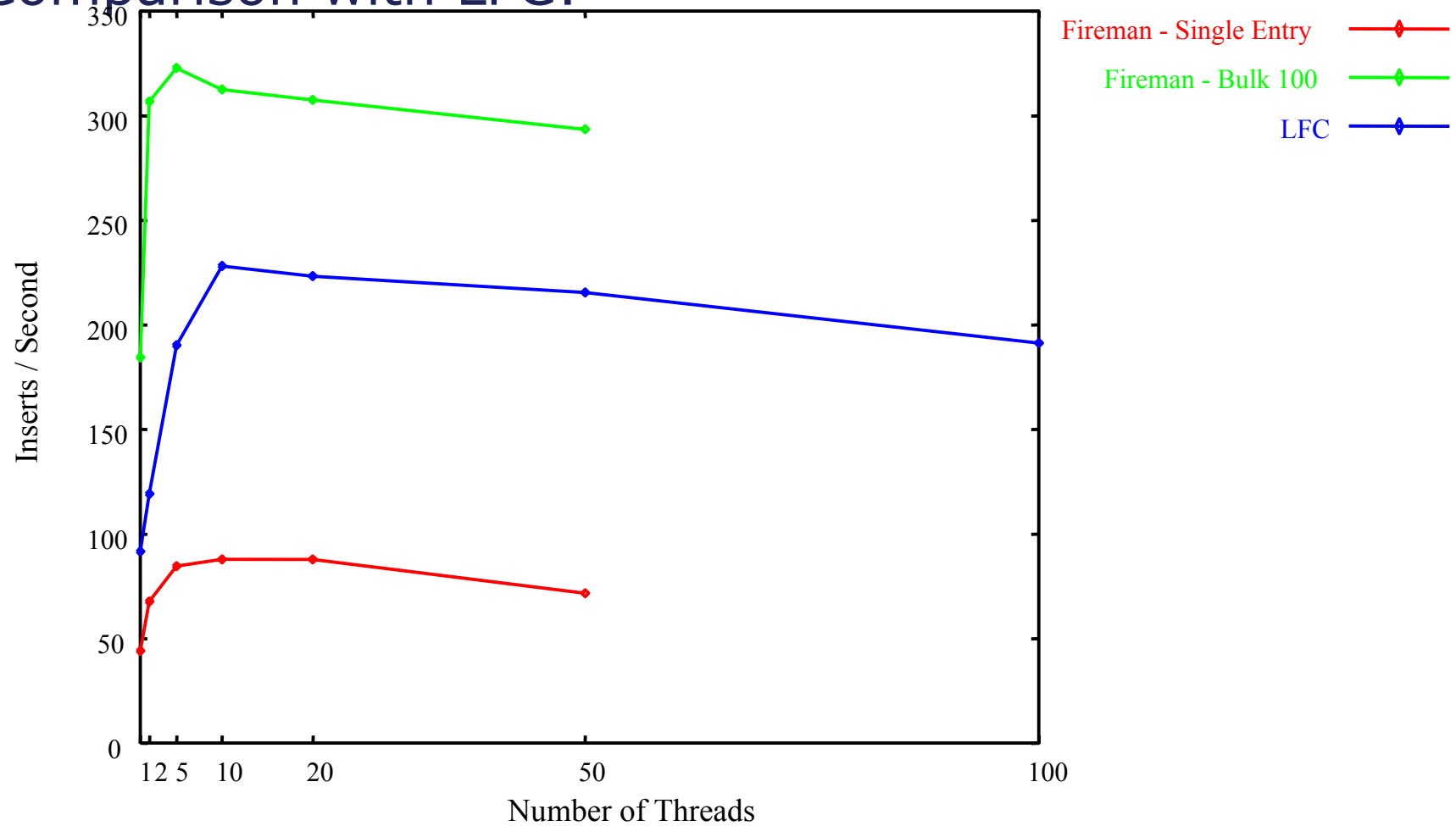



FiReMan Performance - Queries



- Comparison with LFC:

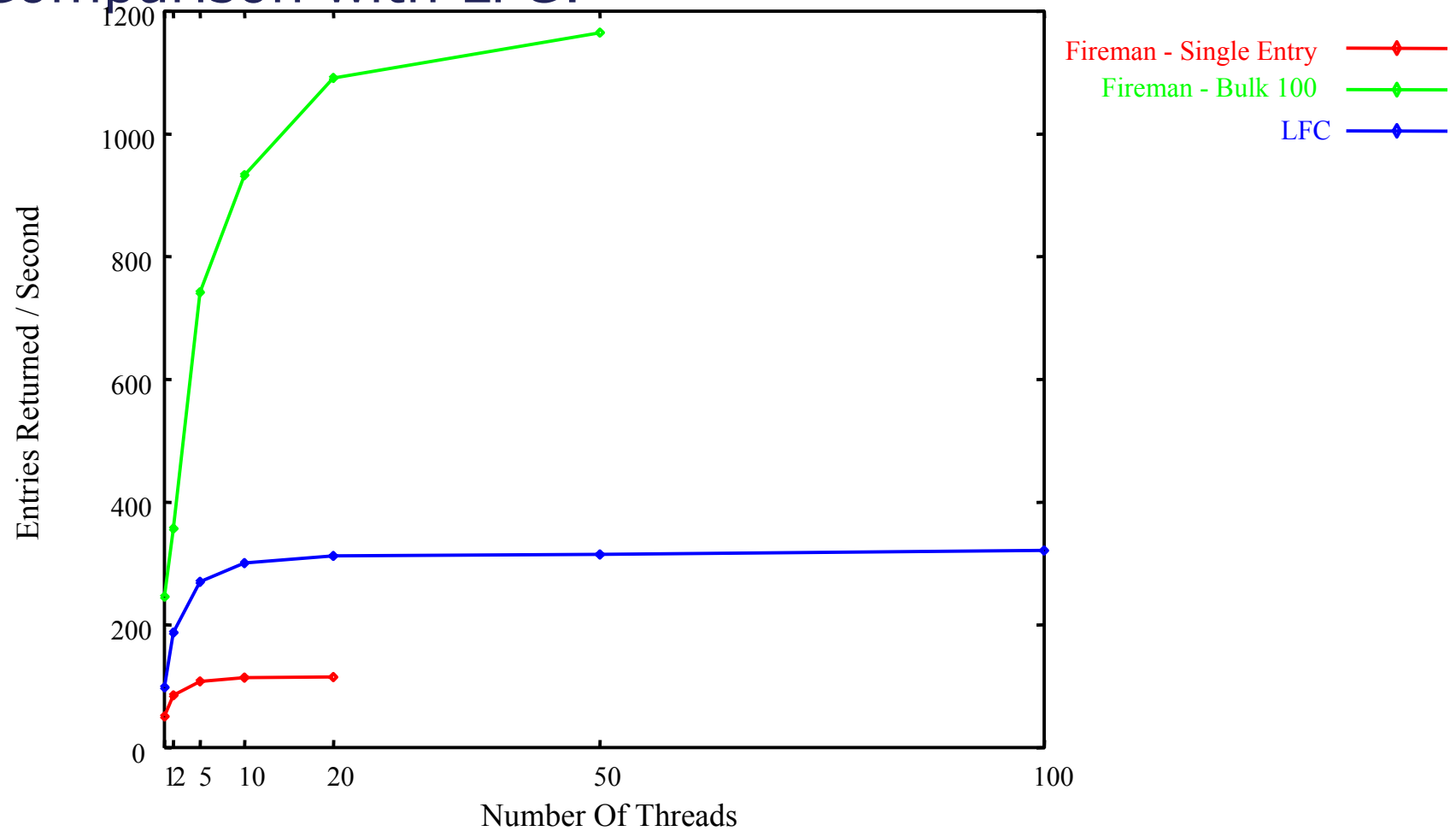



Tests Conclusion



- Both LFC and FiReMan offer large improvements over RLS
- Still some issues remaining:
 - Scalability of FiReMan
 - Bulk Entry for LFC
- More work needed to understand performance and bottlenecks
- Need to test some real Use Cases



Overview



- LFC Architecture
- LFC/Fireman Tests
- **LFC Deployment**



From the RLS to the LFC



- EDG-RLS
 - Central catalog
 - Performance and Scalability problems during experiment DCs in 2004
- LFC developed as a possible solution for LCG
 - Central catalog or local catalog
- Catalog called “LCG File Catalog”, but not HEP specific !
- Secure LFC is part of LCG-2_4_0
 - Easy installation/configuration : RPMs or tarballs
 - YAIM components provided (for MySQL only at the moment)
 - LFC Administrator’s Guide
http://goc.grid.sinica.edu.tw/gocwiki/How_to_set_up_an_LFC_service
 - Several sites are currently testing the LFC



RLS to LFC Migration



- Simple script provided by the CERN IT-GD group
 - Queries the LRC and RMC databases directly (for efficiency reasons)
 - No user-defined entries migrated by default
 - But, script already exists for file size and checksum
 - Can be changed on demand if user-defined attributes fit in the LFC model

- Example :

```
./migrate_RLS_entries --db-vendor MySQL --host localhost  
--lrc-user lrc_zeus --lrc-passwd lrc_password  
--rmc-user rmc_zeus --rmc-passwd rmc_password  
--path /grid/zeus
```

- More details at :

[http://goc.grid.sinica.edu.tw/gocwiki/How to migrate the RLS entries into the LCG File Catalog %28LFC%29](http://goc.grid.sinica.edu.tw/gocwiki/How_to_migrate_the_RLS_entries_into_the_LCG_File_Catalog_%28LFC%29)



LFC Integration



- LFC already accessible through :
 - LFC command line interface
 - lfc-ls, lfc-mkdir, lfc-ln, lfc-rm, lfc-rename, lfc-getacl, etc.
 - GFAL
 - lcg_util
 - export LCG_GFAL_INFOSYS=<BDII_hostname>
 - export LCG_CATALOG_TYPE=lfc
 - export LFC_HOST=`lcg-infosites --vo dteam lfc`
 - Python interface
 - POOL (on going)



LFC usage example



lxslc3.cern.ch - PuTTY

```
[slemaitr@lxb0709 ~]$
[slemaitr@lxb0709 ~]$
[slemaitr@lxb0709 ~]$
[slemaitr@lxb0709 ~]$
[slemaitr@lxb0709 ~]$
[slemaitr@lxb0709 ~]$
[slemaitr@lxb0709 ~]$
[slemaitr@lxb0709 ~]$
[slemaitr@lxb0709 ~]$
[slemaitr@lxb0709 ~]$
[slemaitr@lxb0709 ~]$ grid-proxy-init
Your identity: /C=CH/O=CERN/OU=GRID/CN=Sophie Lemaitre 2268
Enter GRID pass phrase for this identity:
Creating proxy ..... Done
Your proxy is valid until: Wed May 11 00:14:41 2005
[slemaitr@lxb0709 ~]$ setenv LCG_CATALOG_TYPE lfc
[slemaitr@lxb0709 ~]$ lcg-cr -v -d lxb0707.cern.ch -l /grid/dteam/sophie/hello2.txt --vo dteam file:/tmp/hello.txt
Using grid catalog type: lfc
Source URL: file:/tmp/hello.txt
File size: 12
Destination specified: lxb0707.cern.ch
Destination URL for copy: gsiftp://lxb0707.cern.ch/flatfiles/SE00/dteam/generated/2005-05-10/file7e3d769d-434e-4e36-a53d-48b8609de597
# streams: 1
Alias registered in Catalog: lfn:/grid/dteam/sophie/hello2.txt
Transfer took 600 ms
Destination URL registered in Catalog: sf://lxb0707.cern.ch/flatfiles/SE00/dteam/generated/2005-05-10/file7e3d769d-434e-4e36-a53d-48b8609de597
guid:76a15f8b-bbdf-4a35-a513-82e1371d6bfa
[slemaitr@lxb0709 ~]$
[slemaitr@lxb0709 ~]$
[slemaitr@lxb0709 ~]$
[slemaitr@lxb0709 ~]$
[slemaitr@lxb0709 ~]$
[slemaitr@lxb0709 ~]$ setenv LFC_HOST `lcg-infosites --vo dteam lfc`
[slemaitr@lxb0709 ~]$ lfc-ls -l /grid/dteam/sophie
-rw-r--r-- 1 18146 cg 12 May 10 12:02 bonjour.txt
-rwxr-xr-x 1 18146 cg 12 May 10 12:00 hello.txt
-rwxr-xr-x 1 18146 cg 12 May 10 12:14 hello2.txt
[slemaitr@lxb0709 ~]$ lfc-chmod 700 /grid/dteam/sophie/hello2.txt
[slemaitr@lxb0709 ~]$ lfc-ls -l /grid/dteam/sophie
-rw-r--r-- 1 18146 cg 12 May 10 12:02 bonjour.txt
-rwxr-xr-x 1 18146 cg 12 May 10 12:00 hello.txt
-rwx----- 1 18146 cg 12 May 10 12:14 hello2.txt
[slemaitr@lxb0709 ~]$
[slemaitr@lxb0709 ~]$
[slemaitr@lxb0709 ~]$
[slemaitr@lxb0709 ~]$
[slemaitr@lxb0709 ~]$
[slemaitr@lxb0709 ~]$
[slemaitr@lxb0709 ~]$
[slemaitr@lxb0709 ~]$
[slemaitr@lxb0709 ~]$
```

start

Presentations

4 Microsoft Office P...

EGEE 03 - Microsoft I...

Microsoft Outlook We...

lxslc3.cern.ch - PuTTY

lxslc3.cern.ch - PuTTY

12:19 PM



LFC future developments



- Bulk operations
- Sessions
- Integration with the ARDA Metadata Catalog
- Integration with VOMS/LCAS/LCMAPS
- Integration with AUTHZ



Questions?

Jean-Philippe.Baud@cern.ch

Sophie.Lemaitre@cern.ch

