

# ISOLDE

Isotope Separation On-Line  
(ISOL)

Mats Lindroos

on

behalf of the CERN ISOLDE team

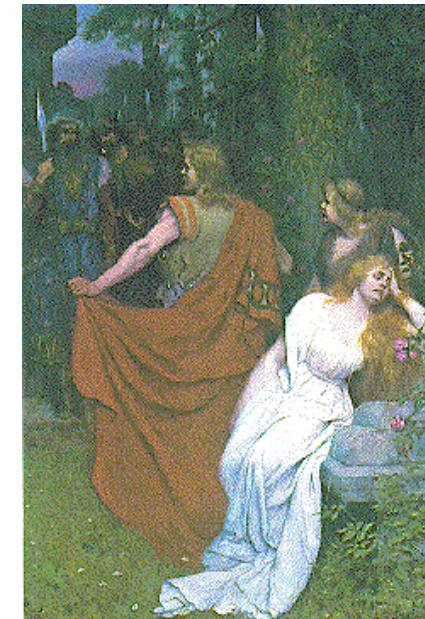

TRISTAN UND ISOLDE: Act II

Summer students  
2005

Mats Lindroos on behalf of the  
ISOLDE team



# ISOL HISTORY

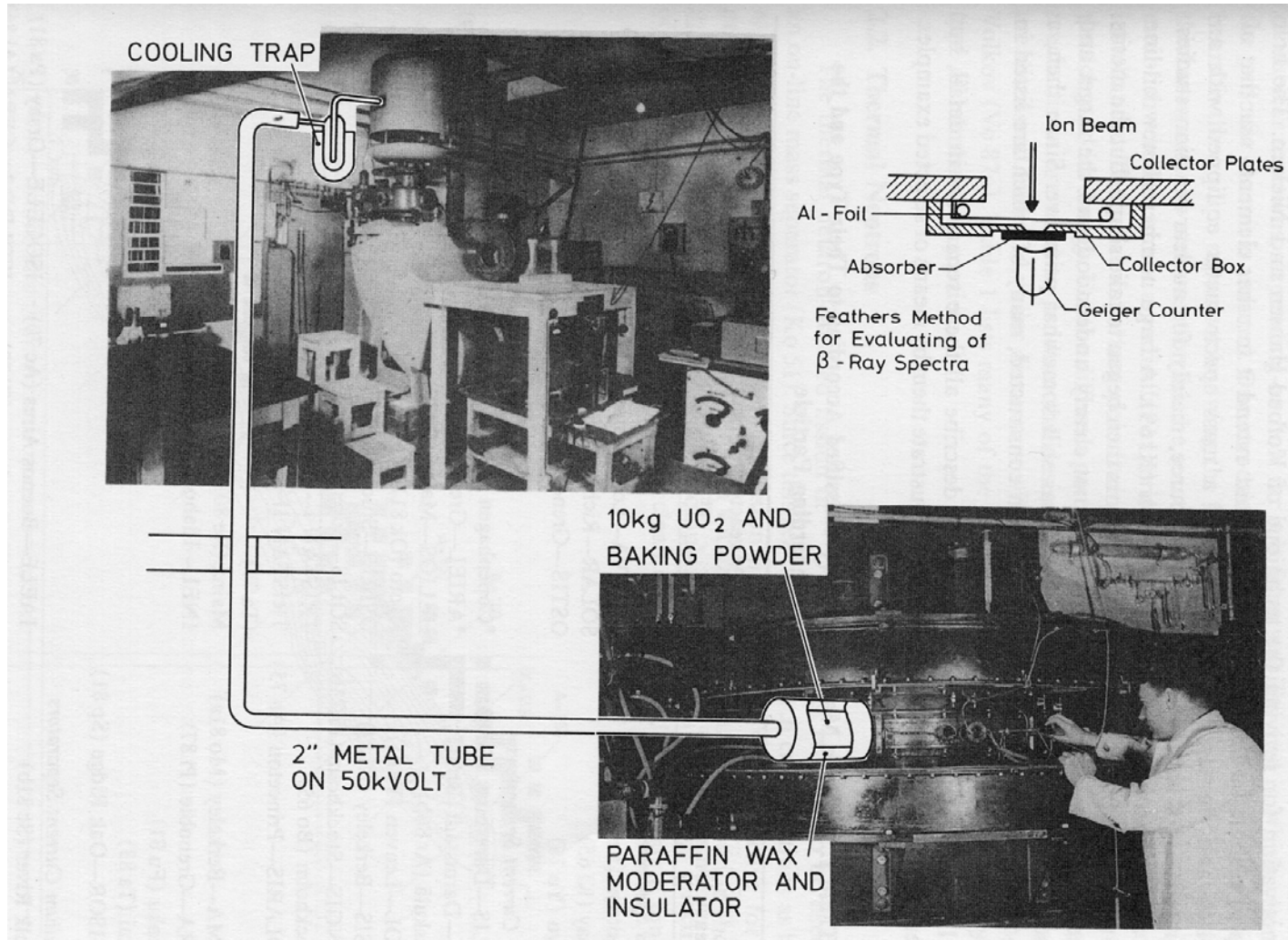
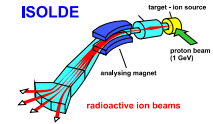

Summer students  
2005

Mats Lindroos on behalf of the  
ISOLDE team



# ISOL ISOTOPE SEPARATION ON-LINE

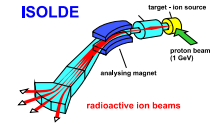

# ISOLDE

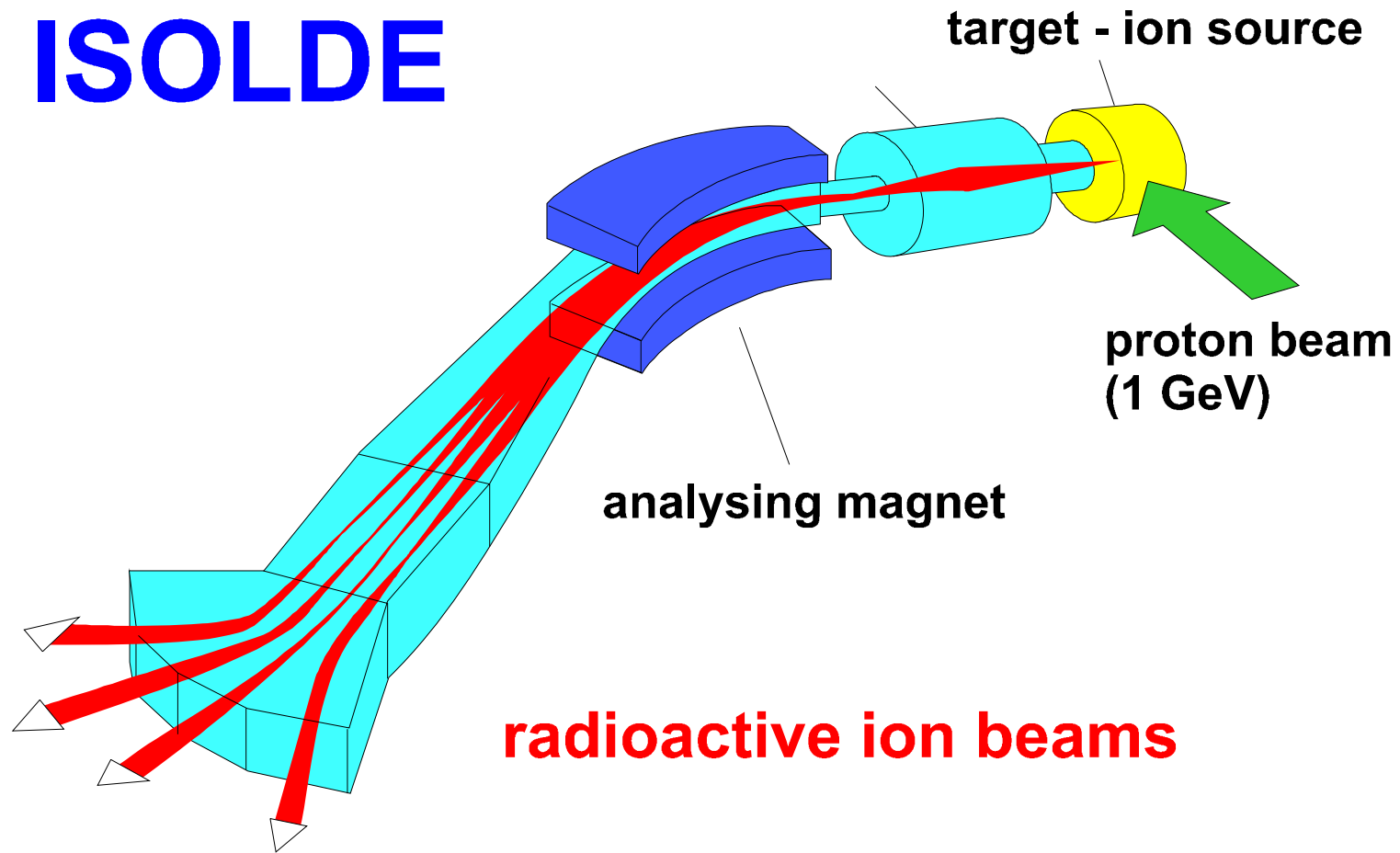

Summer students  
2005

Mats Lindroos on behalf of the  
ISOLDE team



## OUTLINE

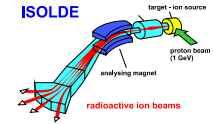

- Overview of the ISOL technique
- ISOLDE-REX, post acceleration of radioactive ions
- Physics at ISOLDE
- Future plans
- Visit



# ISOLDE@CERN

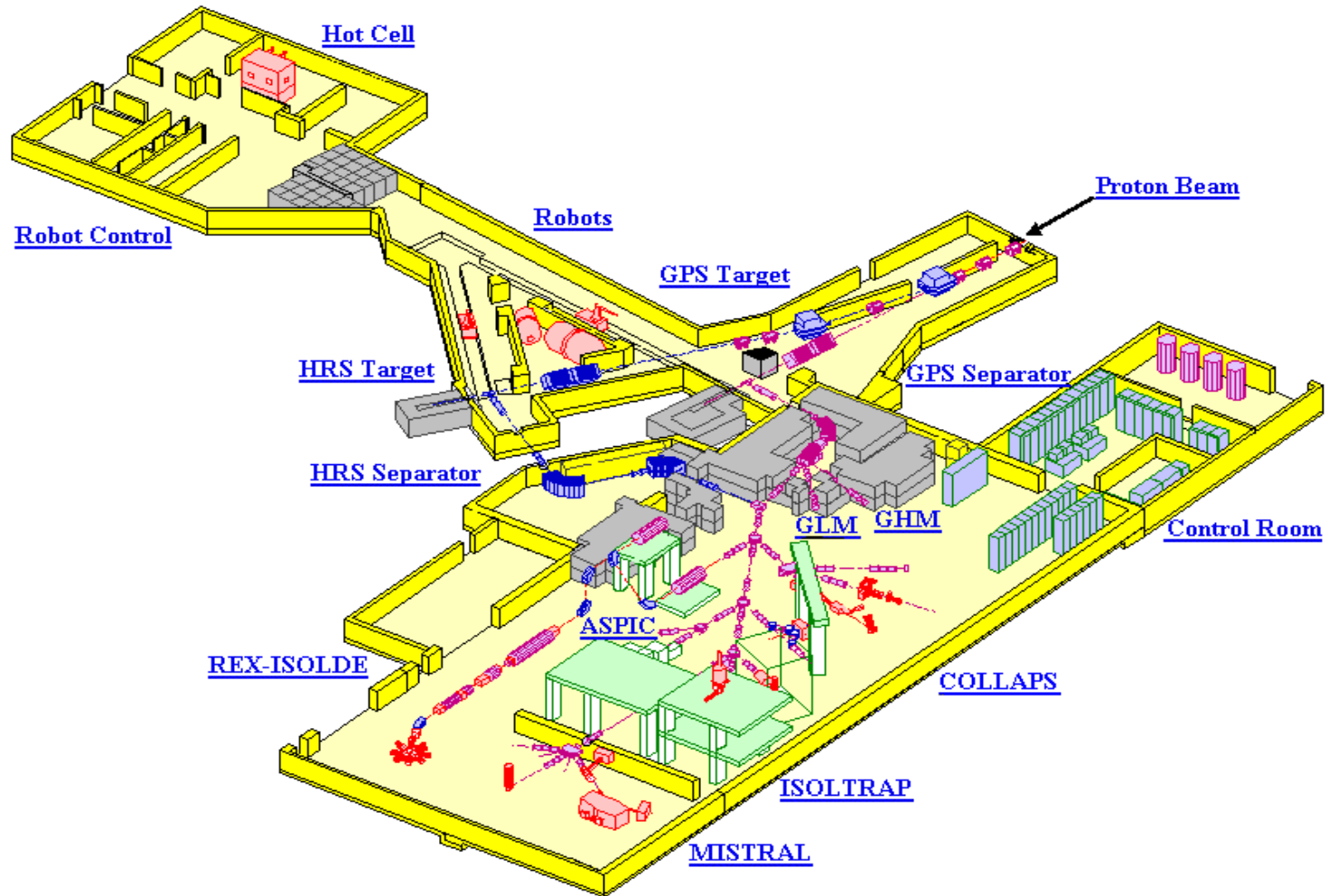
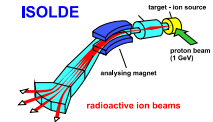

Summer students  
2005

Mats Lindroos on behalf of the  
ISOLDE team



# PS BOOSTER

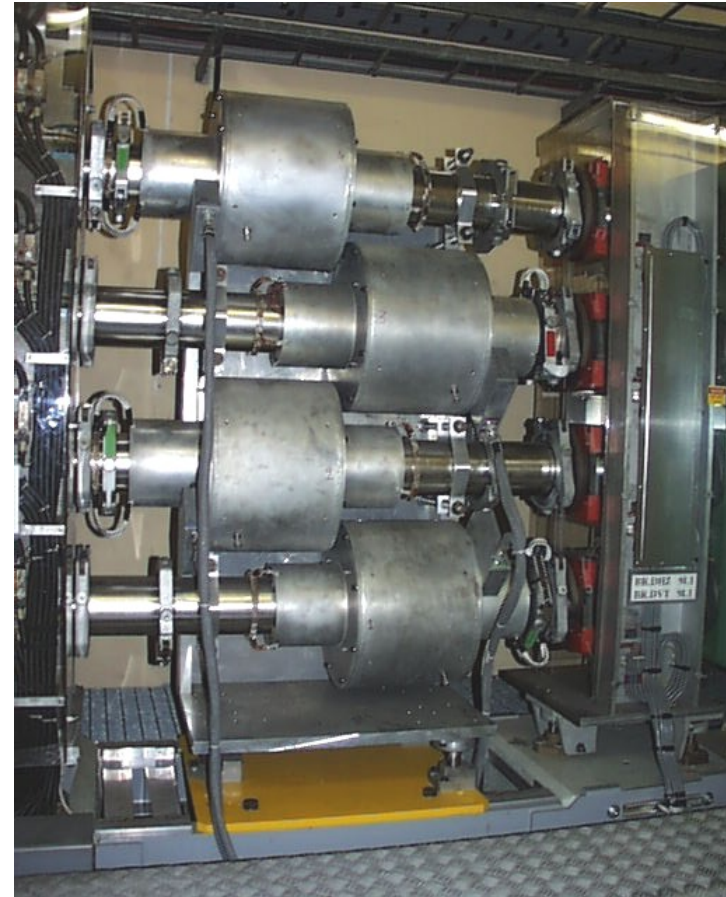
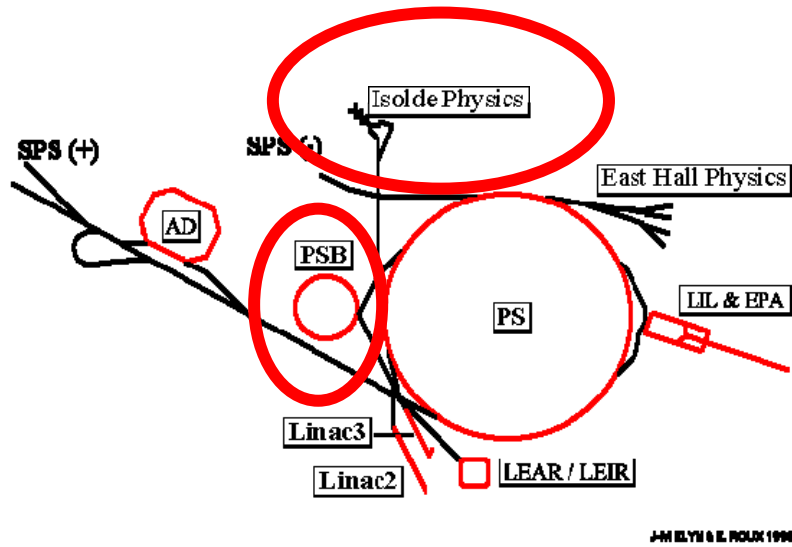
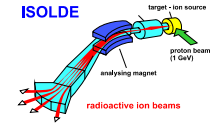

Summer students  
2005

Mats Lindroos on behalf of the  
ISOLDE team



# PRODUCTION OF EXOTIC IONS

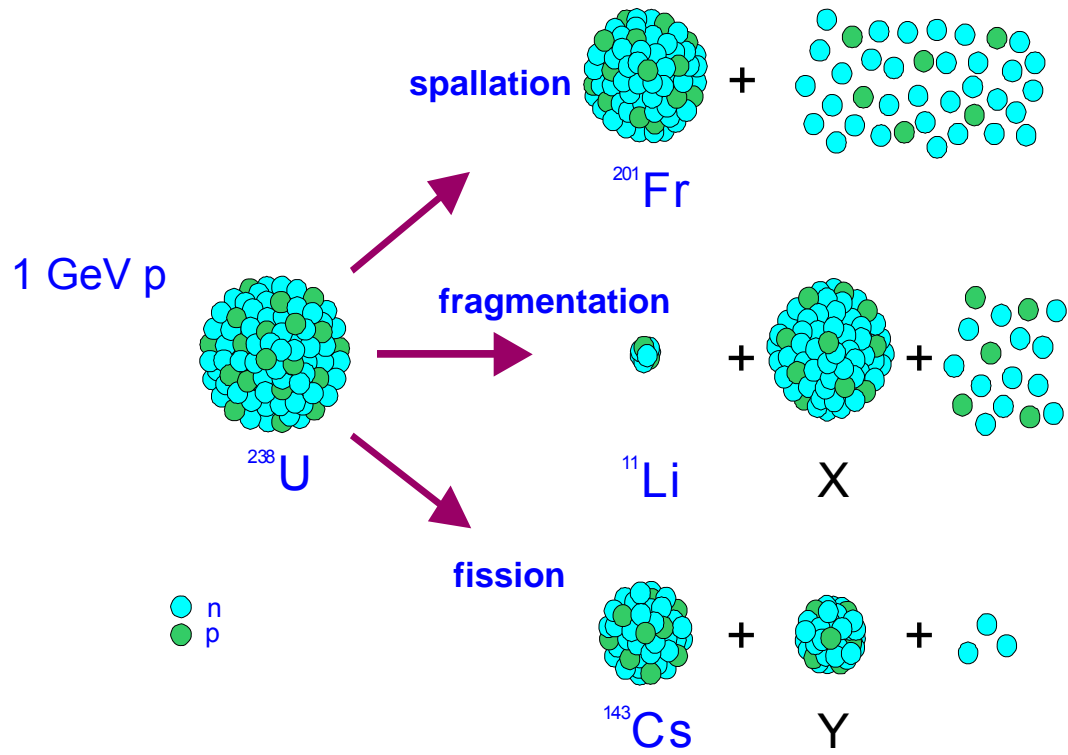
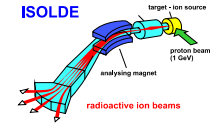



# PRODUCTION YIELDS

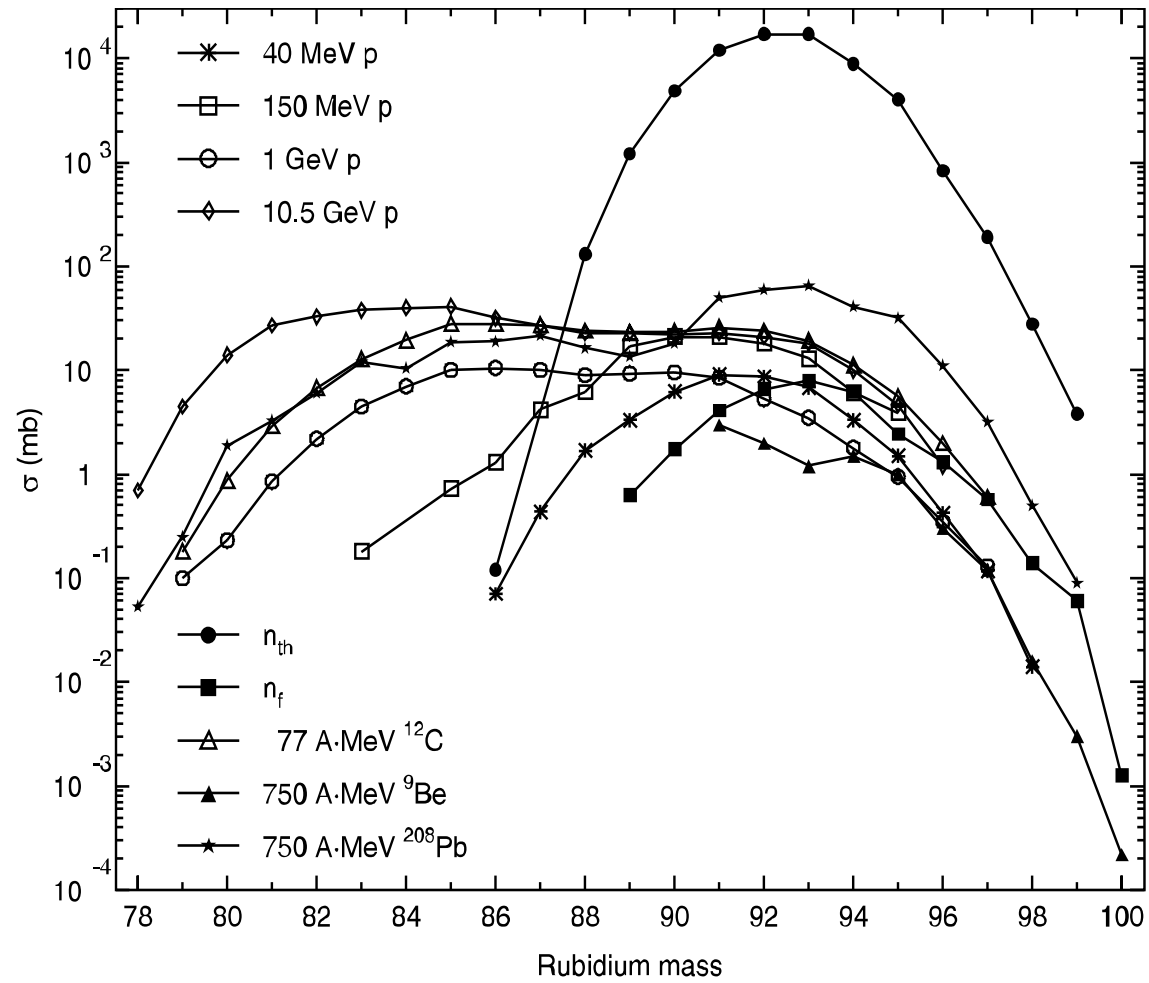
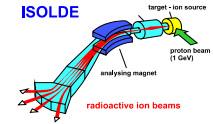

Summer students  
2005

Mats Lindroos on behalf of the  
ISOLDE team





# CROSS SECTIONS

ENERGY DEPENDENCE

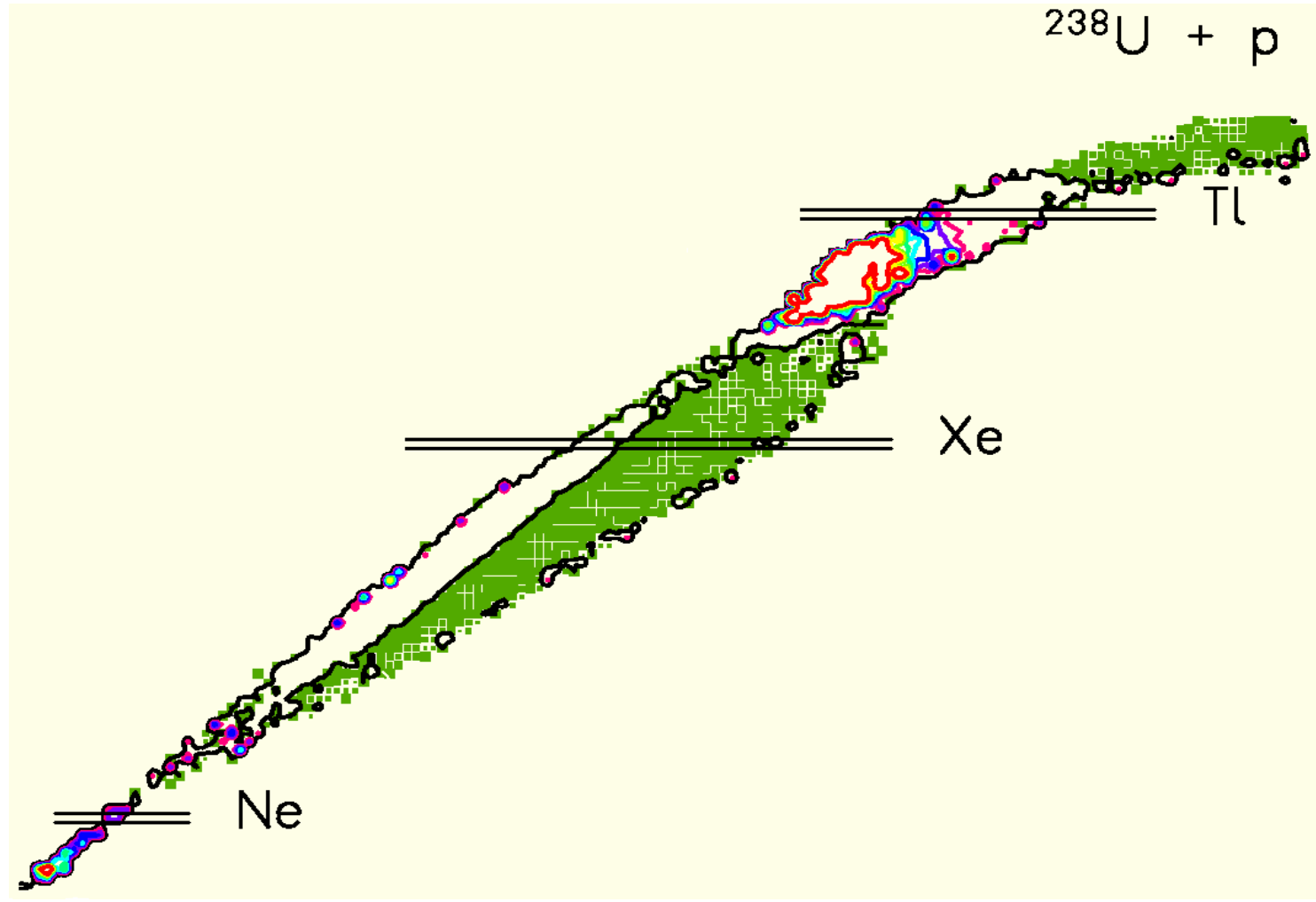
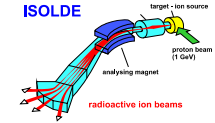

Summer students  
2005

Mats Lindroos on behalf of the  
ISOLDE team



# TARGET

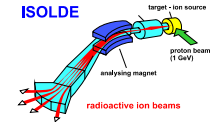

## Thermochemical and physical principles

- Diffusion
- Effusion

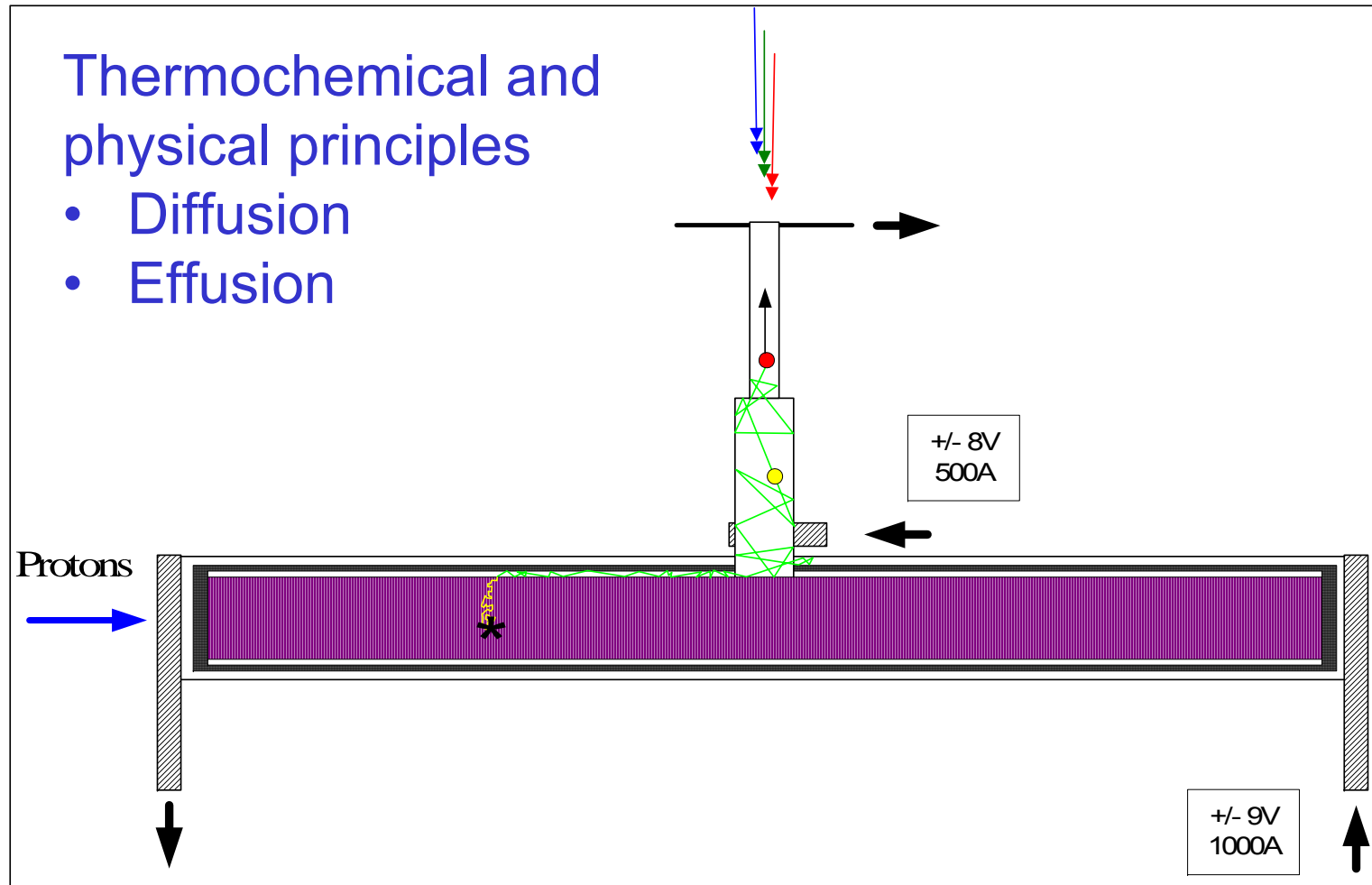



# TARGET

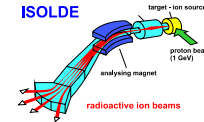

ISOLDE target and ion-source unit

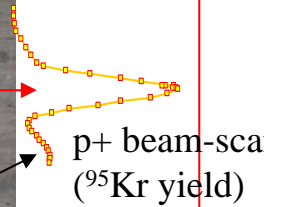
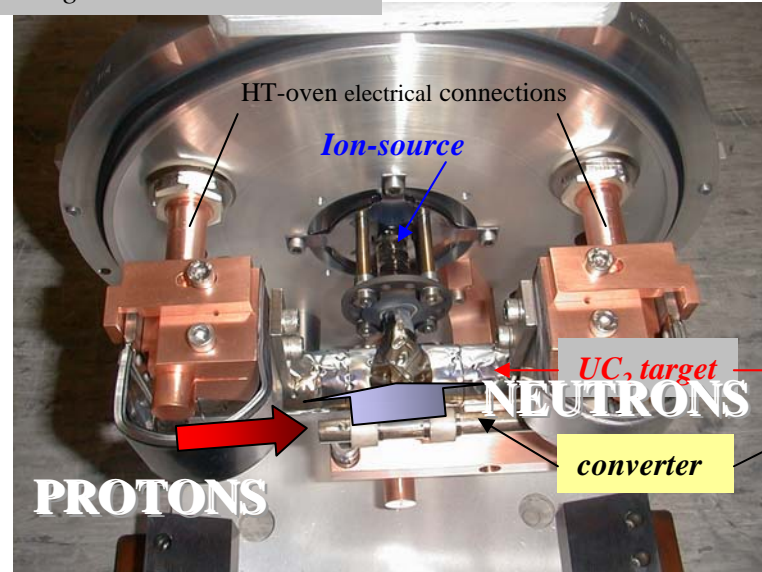

The thermal shock of the proton's  $dE/dx$  is transferred to the "cold" converter.

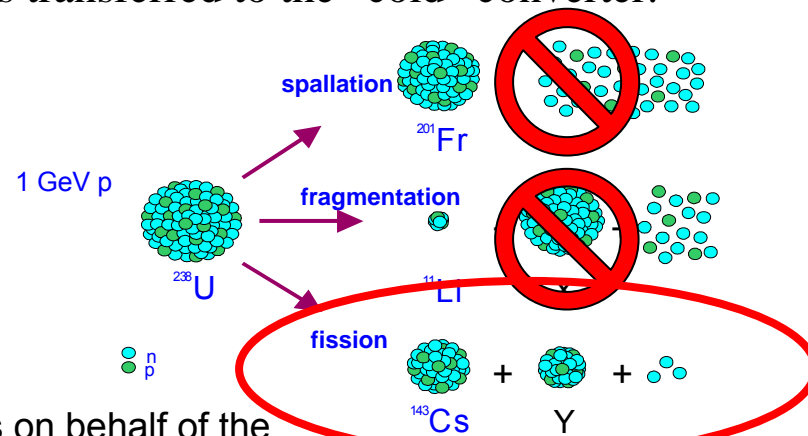

Summer students  
2005

Mats Lindroos on behalf of the  
ISOLDE team

**J. Lettry et al.**



# MONOECR (AT ISOLDE)

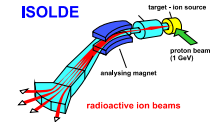

## ISOECRIS

- based on a ISOLDE unit
- coils
- consumable unit
- Running off-line

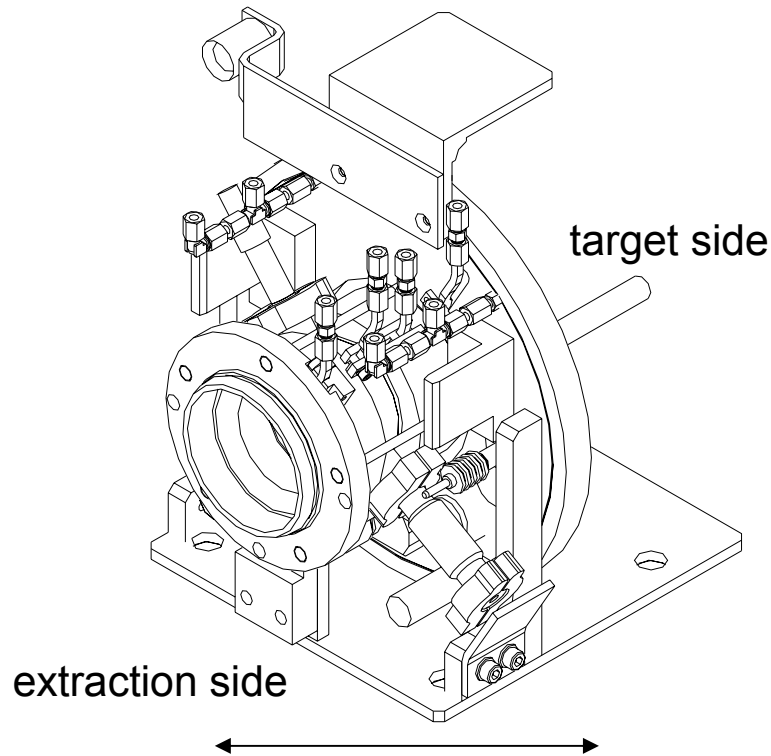

Summer students  
2005

## MINIMONO ISOLDE

- GANIL design [1,2]
- 'standard' ISOLDE unit
- permanent magnets
- consumable unit
- Running on-line

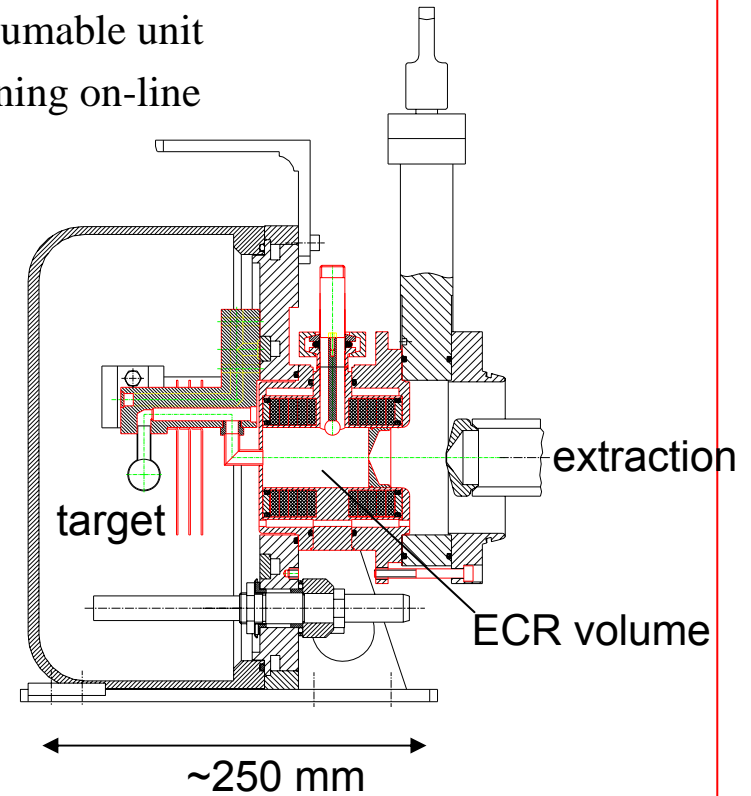

Mats Lindroos on behalf of the  
ISOLDE team

F. Wenander, J. Lettry



# ION SOURCE

## LASER IONIZATION

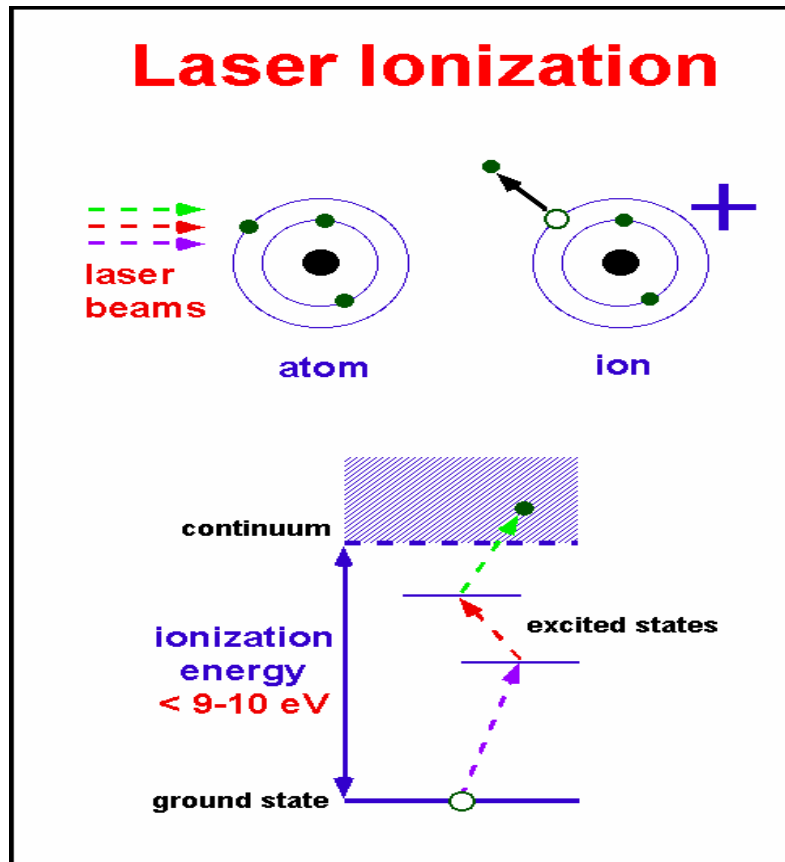
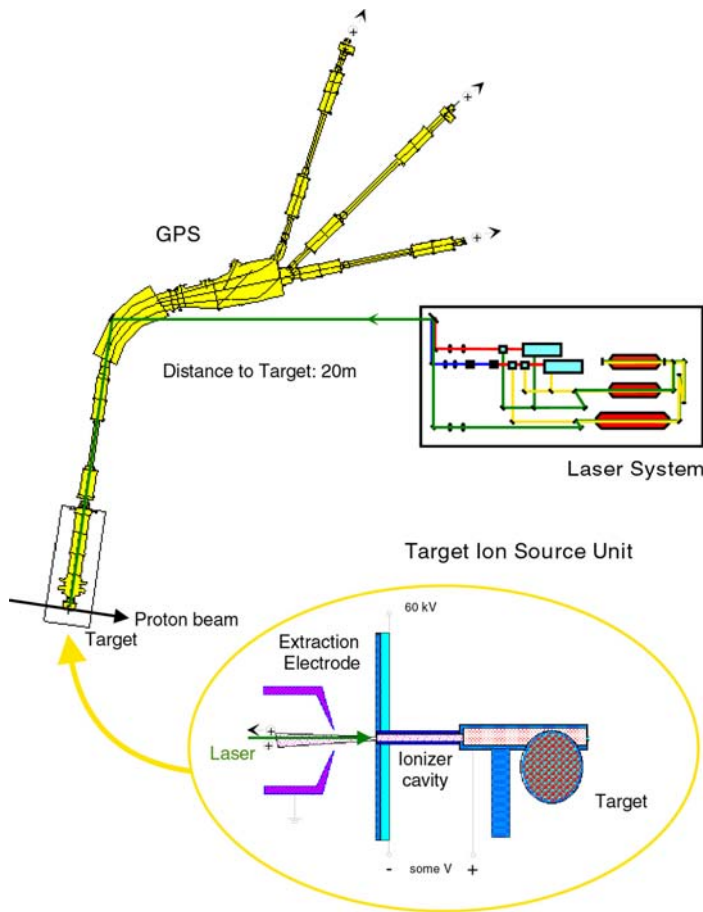
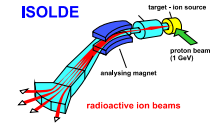

Summer students  
2005

Mats Lindroos on behalf of the  
ISOLDE team



# ISOLDE TARGET CHANGE

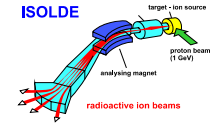

Summer students  
2005

Mats Lindroos on behalf of the  
ISOLDE team



# MAGNETIC SEPARATION

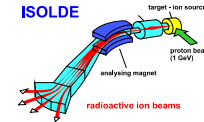

High resolution mass spectrometer, 4 dipole magnets

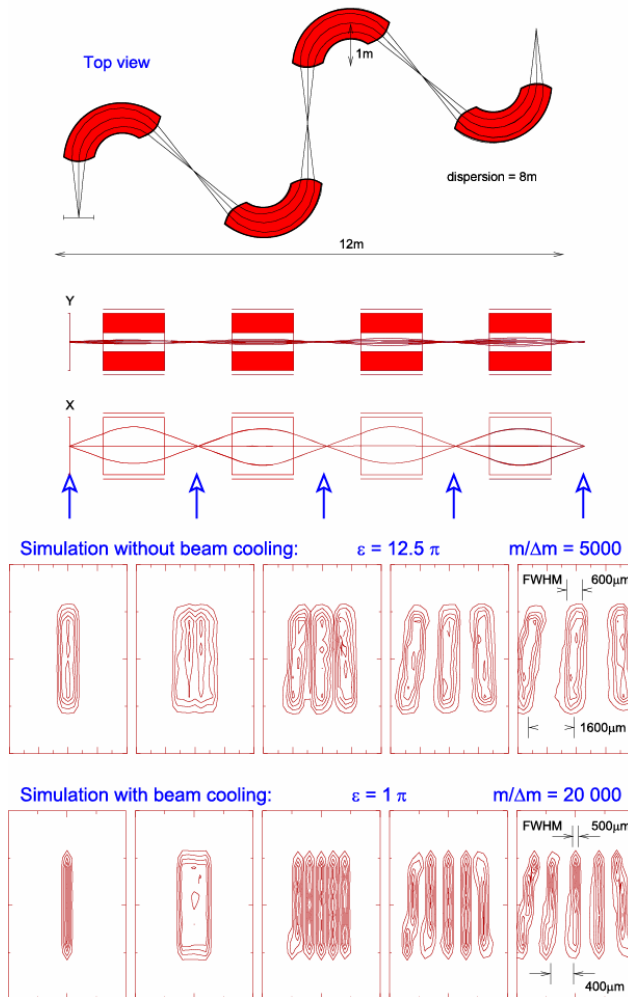

- “Isobaric” separation
- Separation limited by the beams transverse size
- Cooling at low energy with RFQ cooler

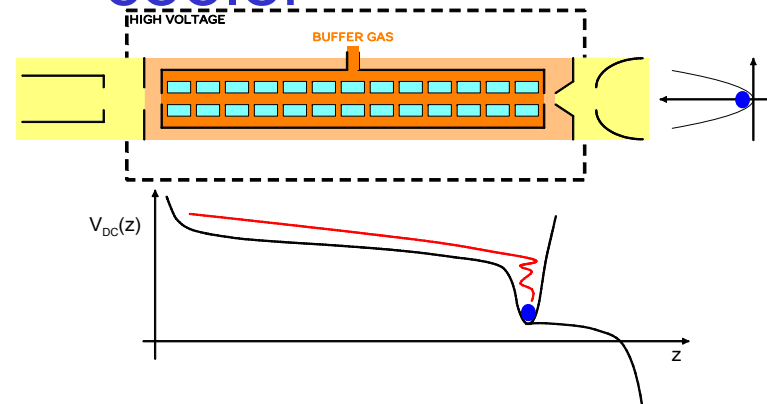

Summer students  
2005

Mats Lindroos on behalf of the  
ISOLDE team



# NUCLEAR CHART @ ISOLDE

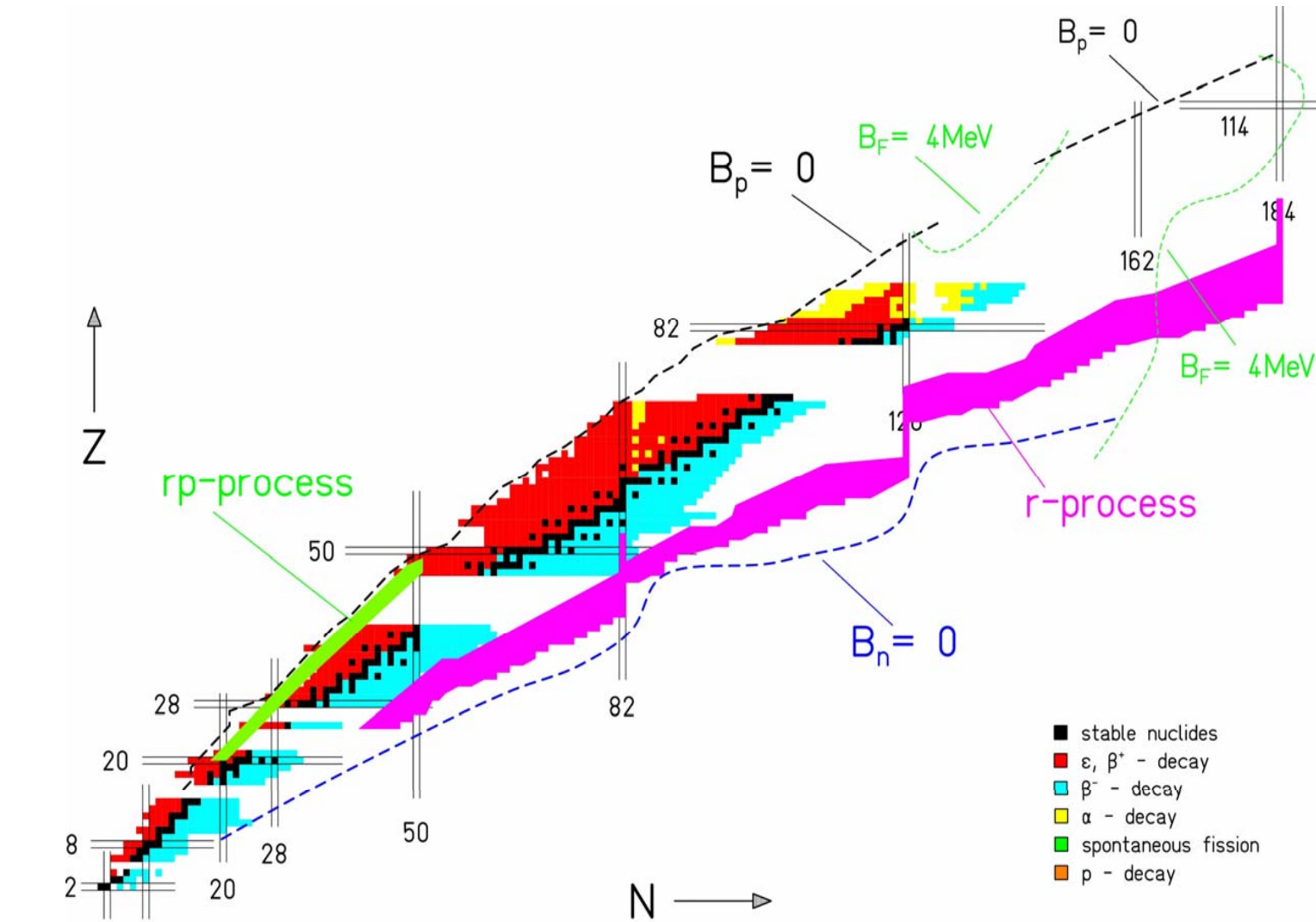
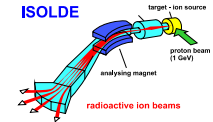

Summer students  
2005

Mats Lindroos on behalf of the  
ISOLDE team





## PURE BEAMS?

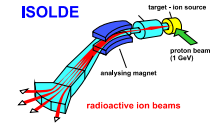

To get pure beams free from isobaric contamination:

- Target material
- Target and ion source chemistry
- Proton energy
- Ion source
- Magnetic separation



# ISOL FACILITIES 1967

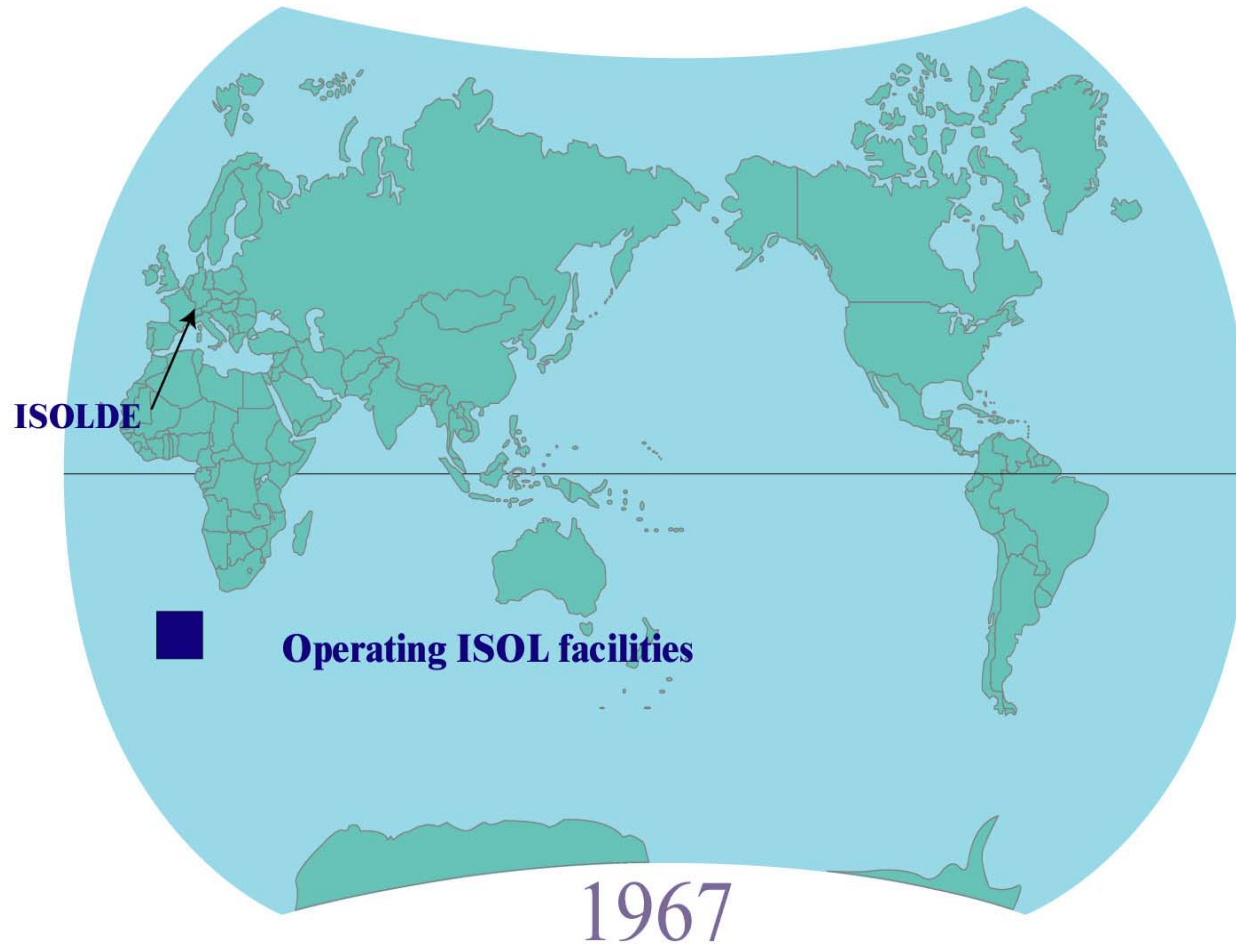
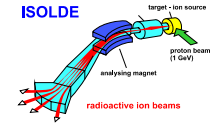

Summer students  
2005

Mats Lindroos on behalf of the  
ISOLDE team



# ISOL FACILITIES 2003

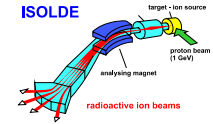

## World Wide Radioactive Beam Facilities

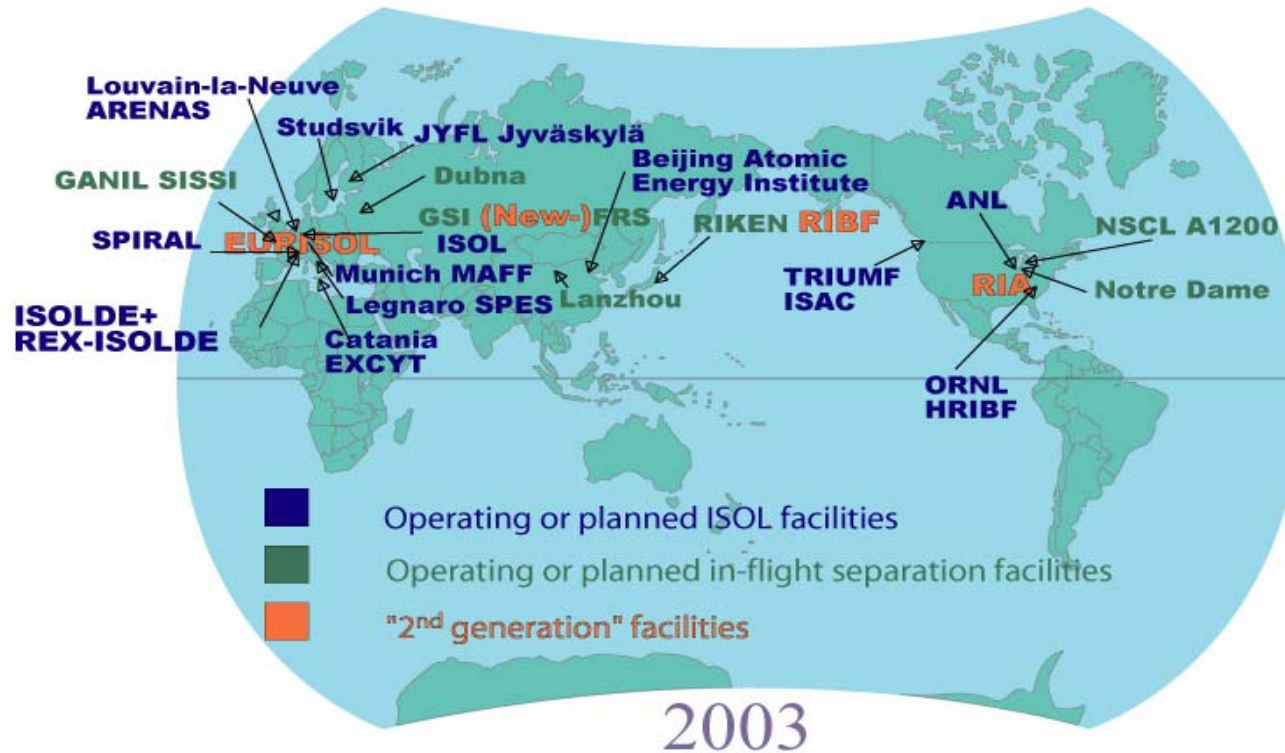

Summer students  
2005

Mats Lindroos on behalf of the  
ISOLDE team



# NUCLEAR LANDSCAPE

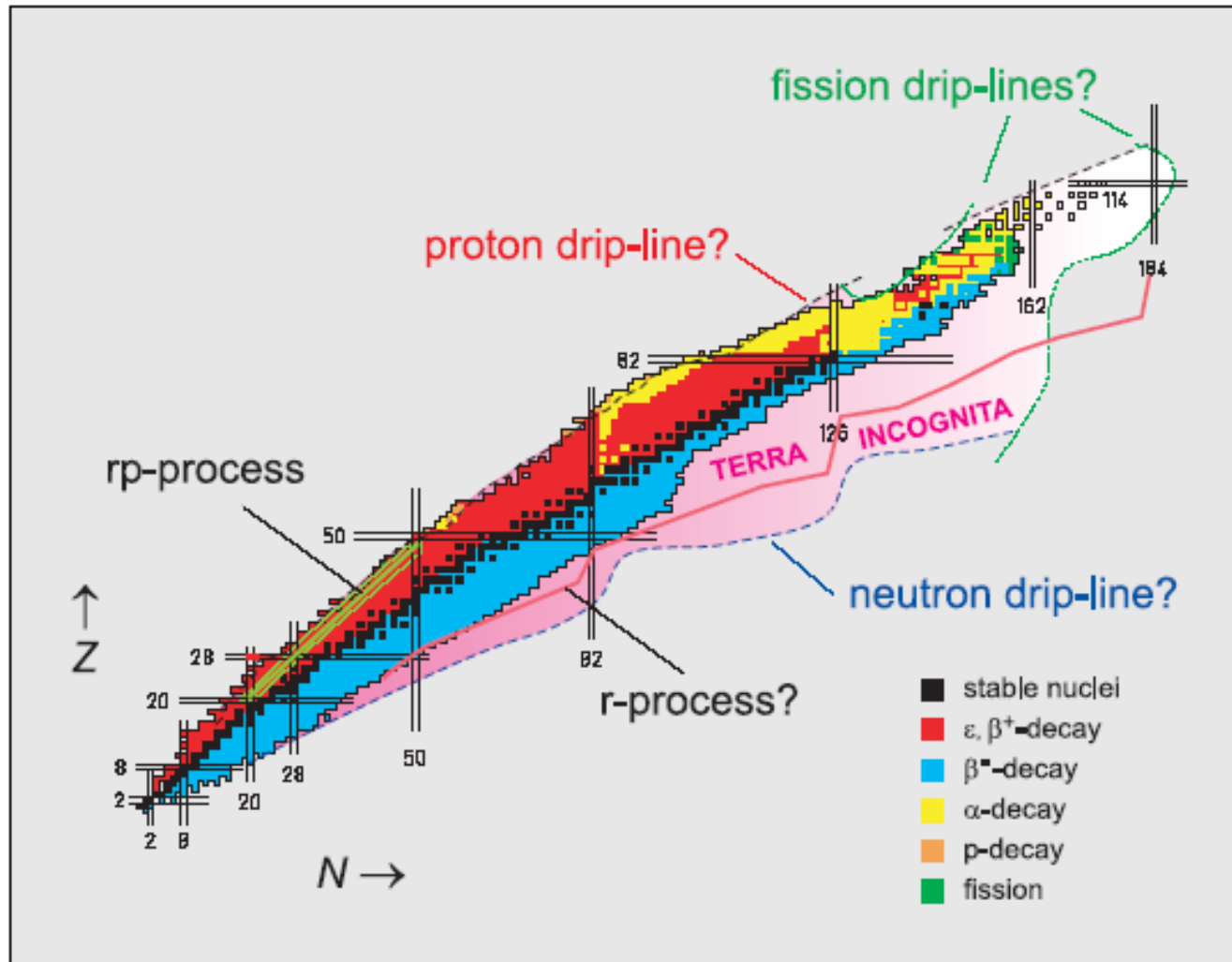
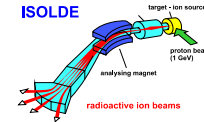

Summer students  
2005

Mats Lindroos on behalf of the  
ISOLDE team



## WHY BOTHER?

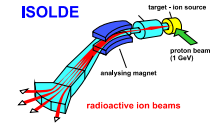

- A few-body system of hadrons (neutrons and protons) with many remaining question marks
- “Largest” system where strong and weak interaction are manifested
- “Applications”
  - Astrophysics
  - Condensed matter
  - Energy
  - Medicine



## WHY NUCLEAR PHYSICS?

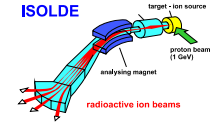

“And why nuclear physics? My answer is the same as that of the young student who chose nuclear physics – *it is a field of basic research with fascinating fundamental problems and applications to many other areas* such as medicine and material science. I believe that nuclear physics is so broad that it is well on the way to becoming *the most general natural science.*”

Professor Paul Kienle, 1993



# PHYSICS AT ISOLDE

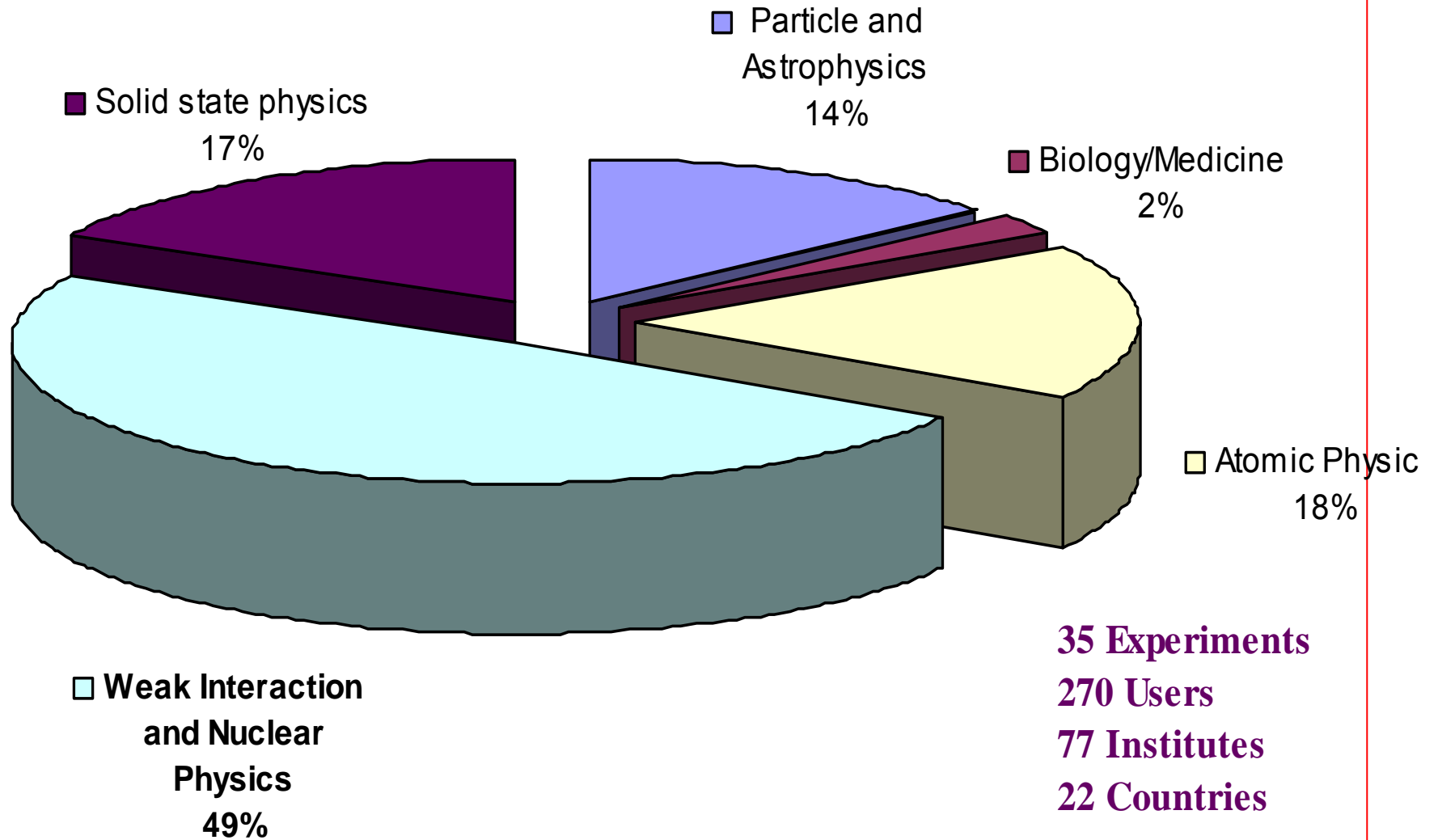
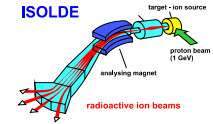

Summer students  
2005

Mats Lindroos on behalf of the  
ISOLDE team



# ASTROPHYSICS

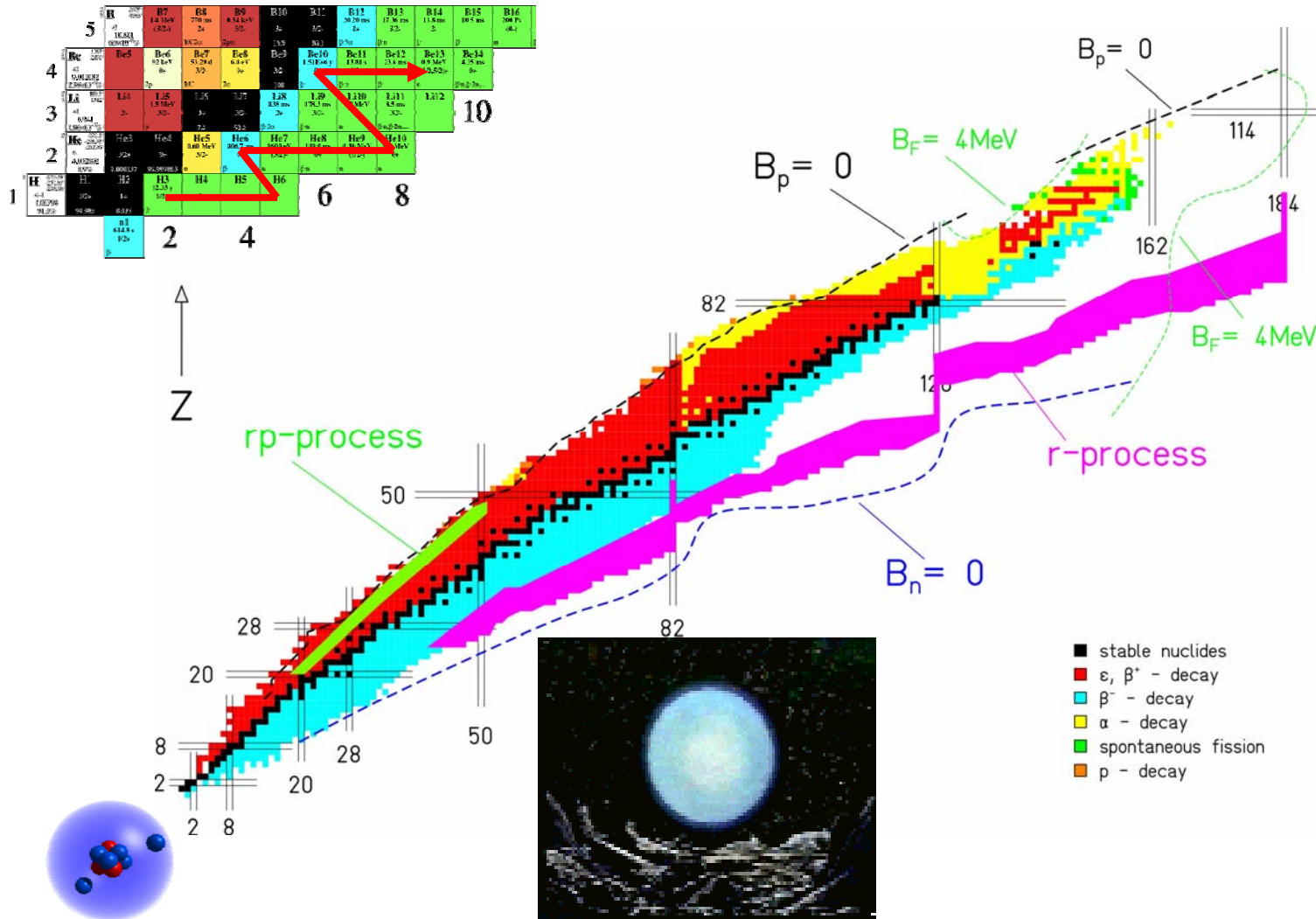
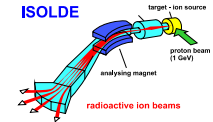

Summer students  
2005

Mats Lindroos on behalf of the  
ISOLDE team





# THREE-PARTICLE BREAK-UP OF LIGHT NUCLEI ( $^{12}\text{C}$ )

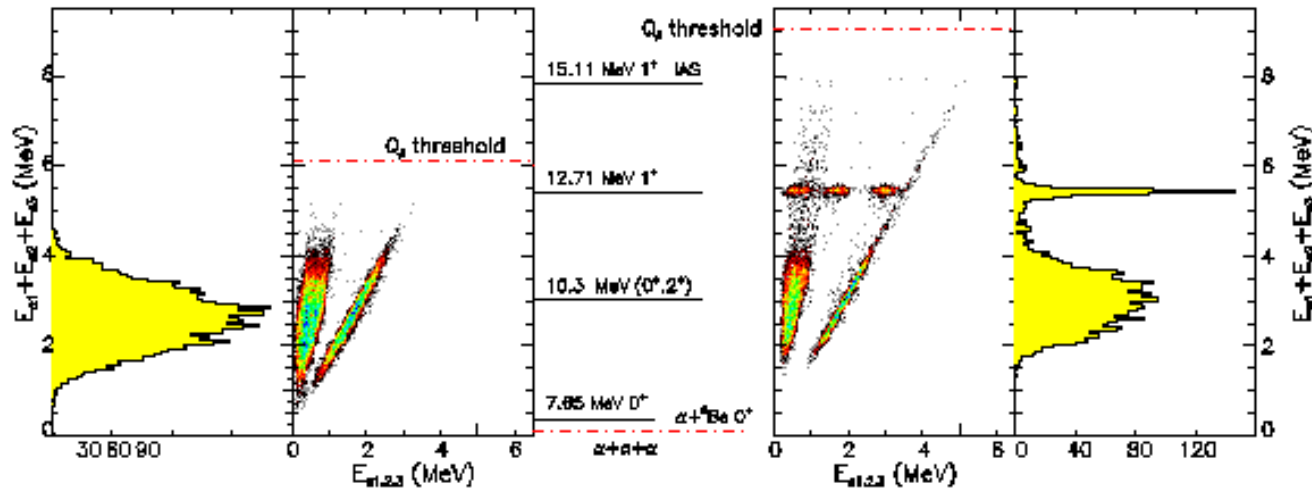
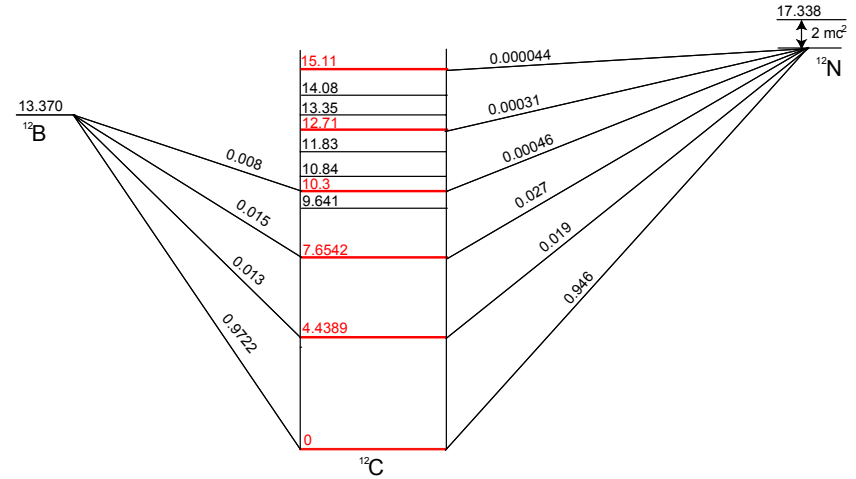
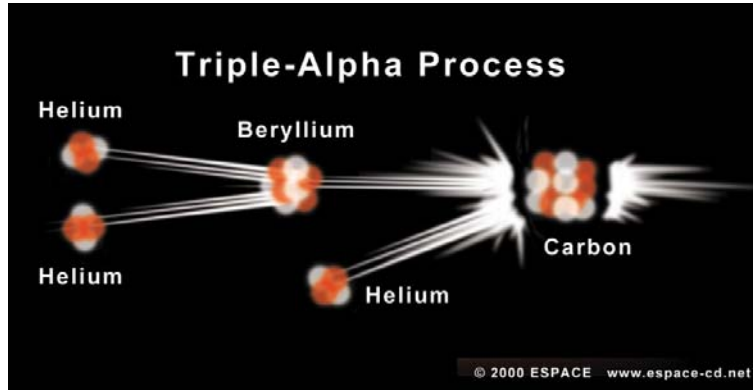
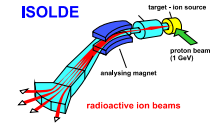

Summer students  
2005

Mats Lindroos on behalf of the  
ISOLDE team



# HALO NUCLEI

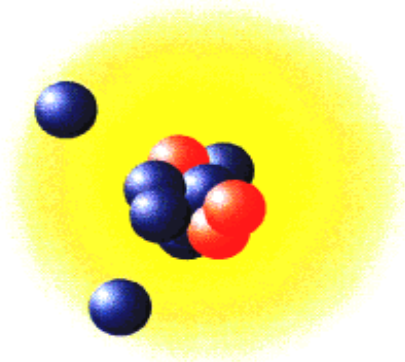
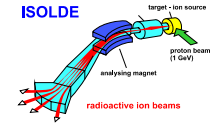

$^{11}\text{Li}$ : Borromean Halo Nucleus



Summer students  
2005

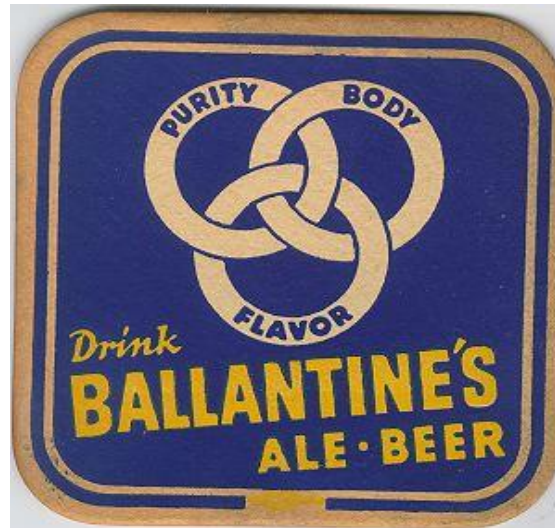

Mats Lindroos on behalf of the  
ISOLDE team

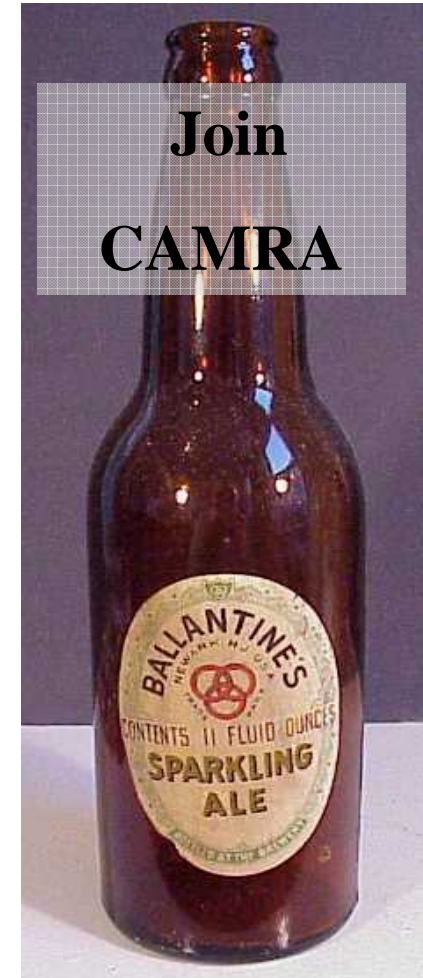



# MASS MODELS

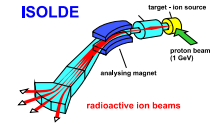

## Constraints for nuclear mass models

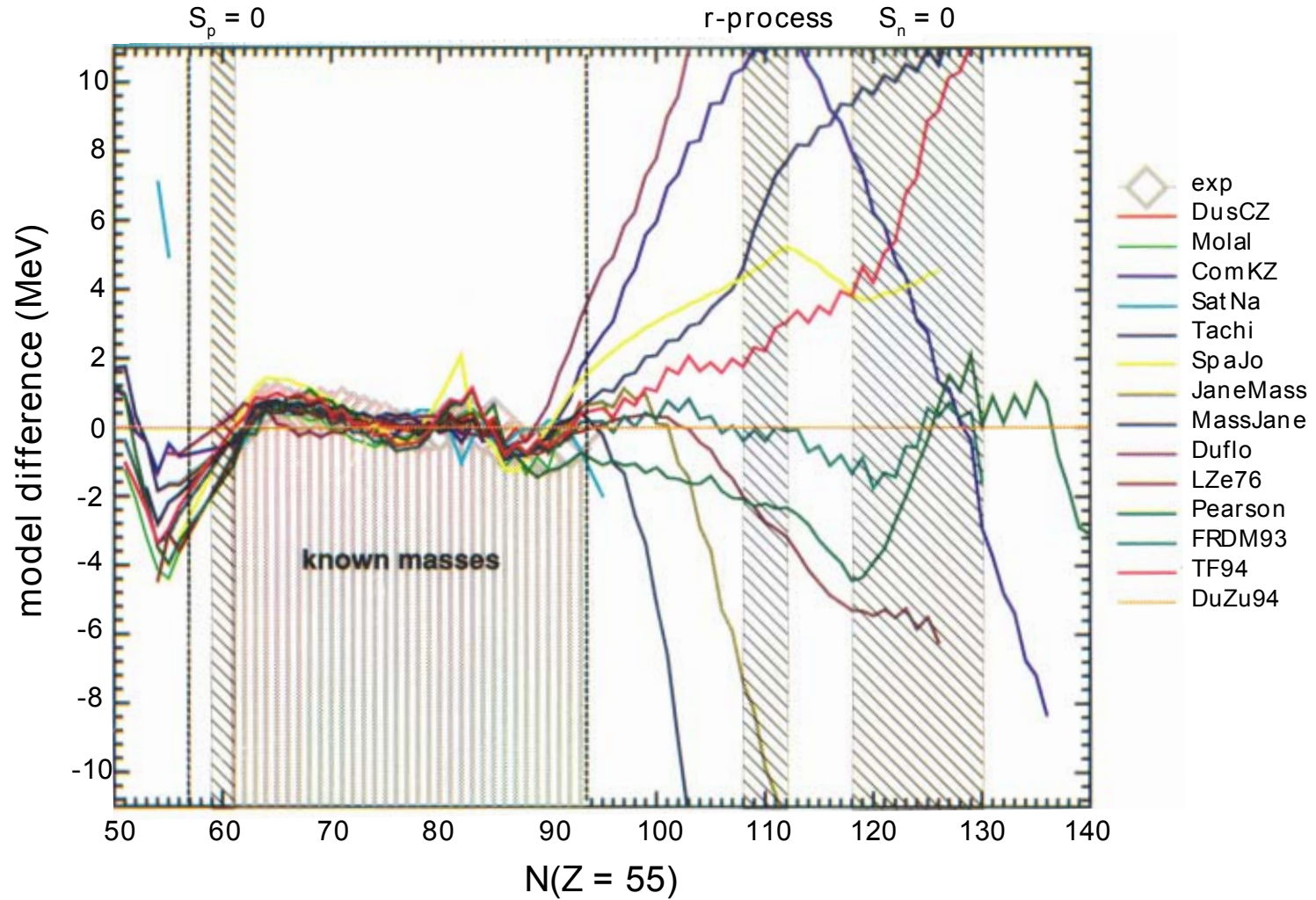

Summer students  
2005

Mats Lindroos on behalf of the  
ISOLDE team



# MASS MEASUREMENTS

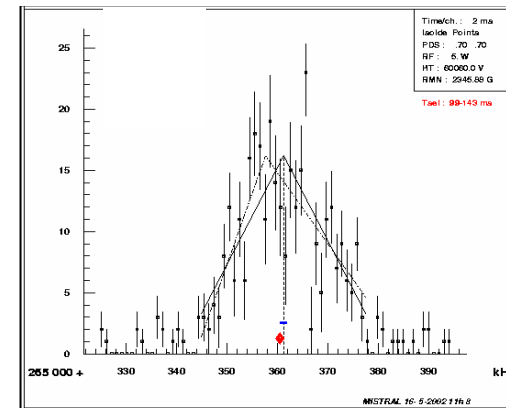
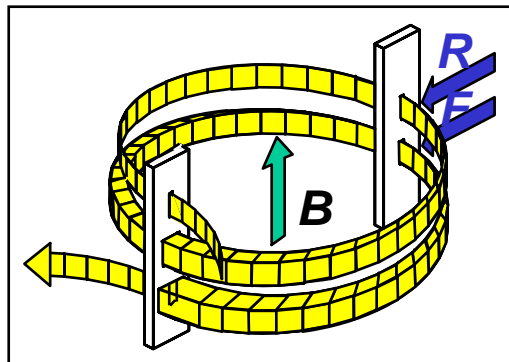
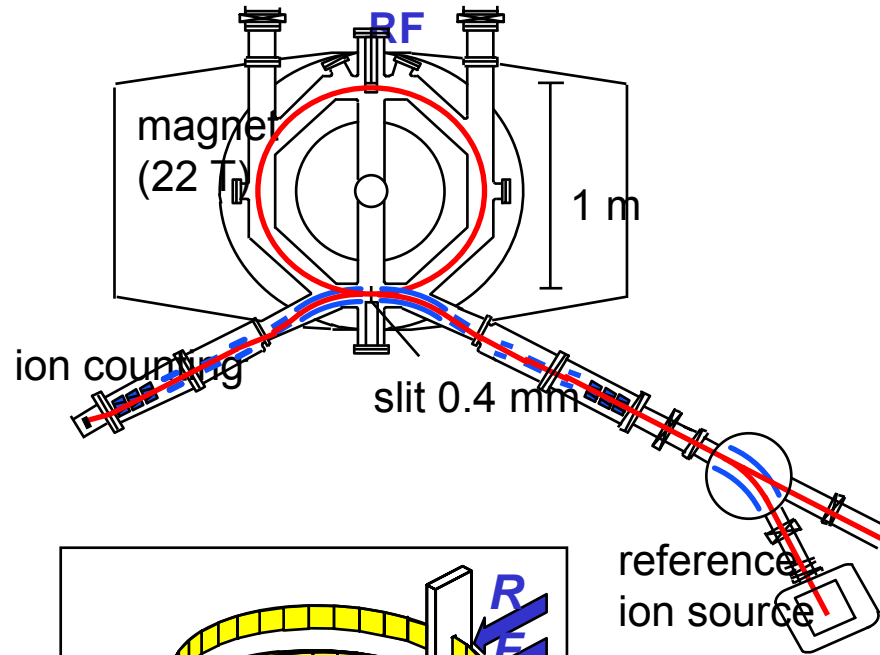
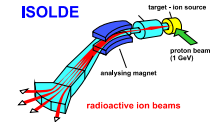

Summer students  
2005

Mats Lindroos on behalf of the  
ISOLDE team

D. Lunney



# MASS MEASUREMENTS

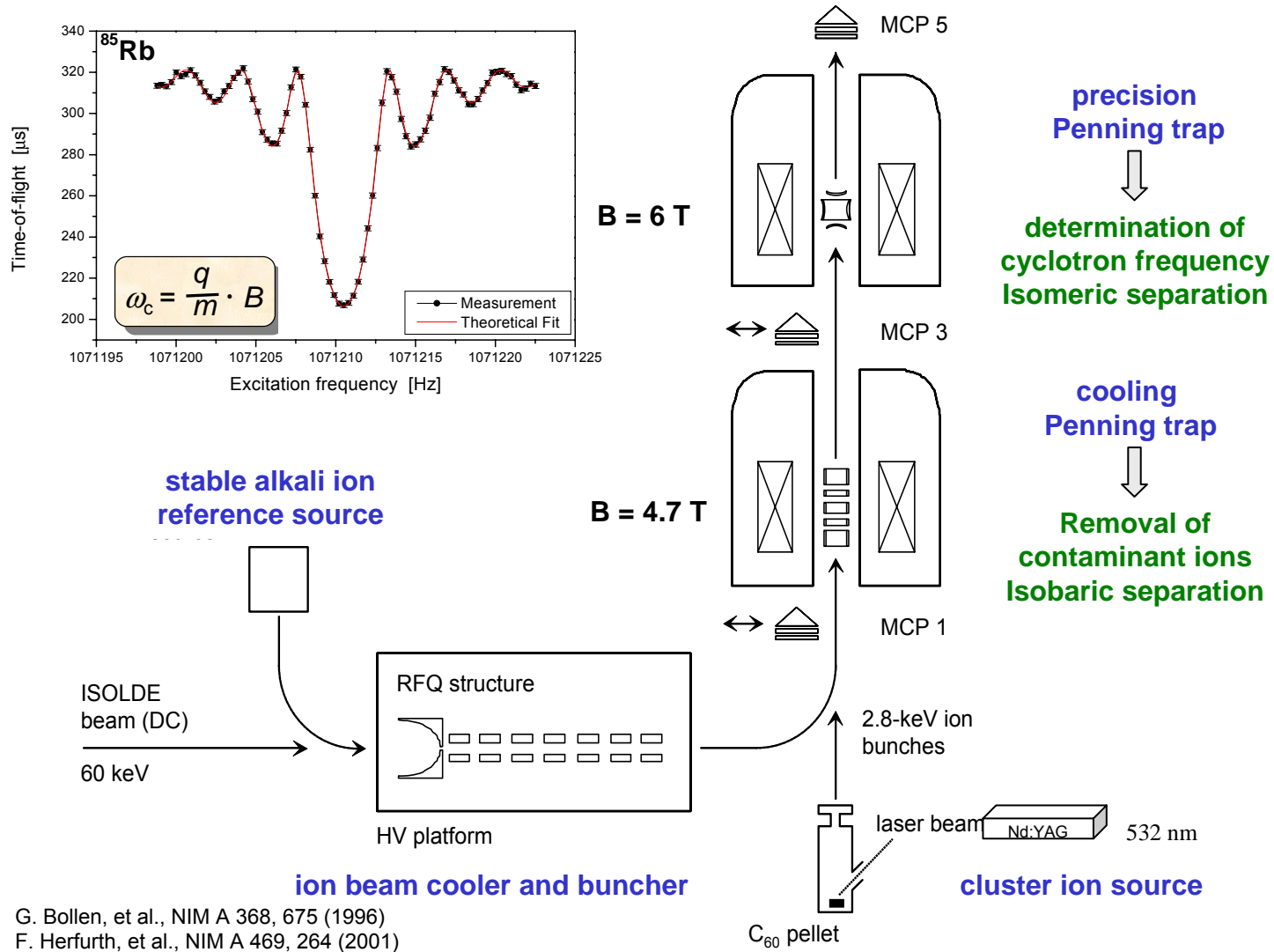
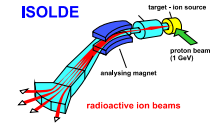

G. Bollen, et al., NIM A 368, 675 (1996)  
F. Herfurth, et al., NIM A 469, 264 (2001)

Summer students  
2005

Mats Lindroos on behalf of the  
ISOLDE team



# SOLID STATE PHYSICS

## RADIOACTIVE IONS AS "SPIES" (PAC) IN HIGH-Tc SUPERCONDUCTORS...

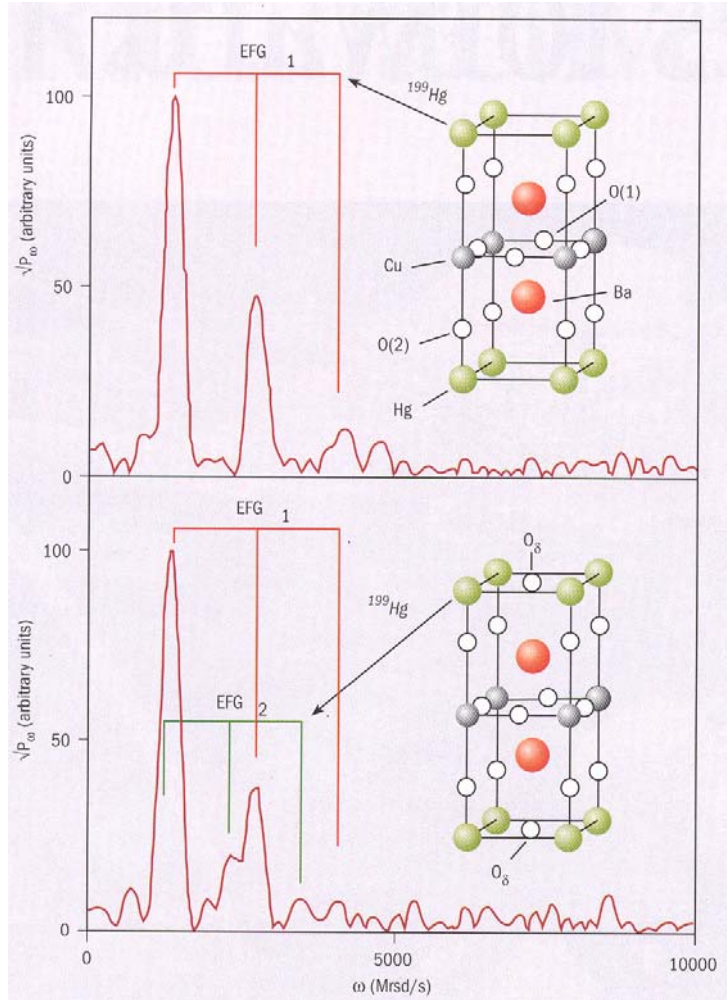
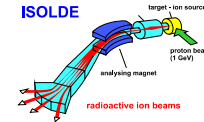

... or as dopants in semiconductors that change with time.

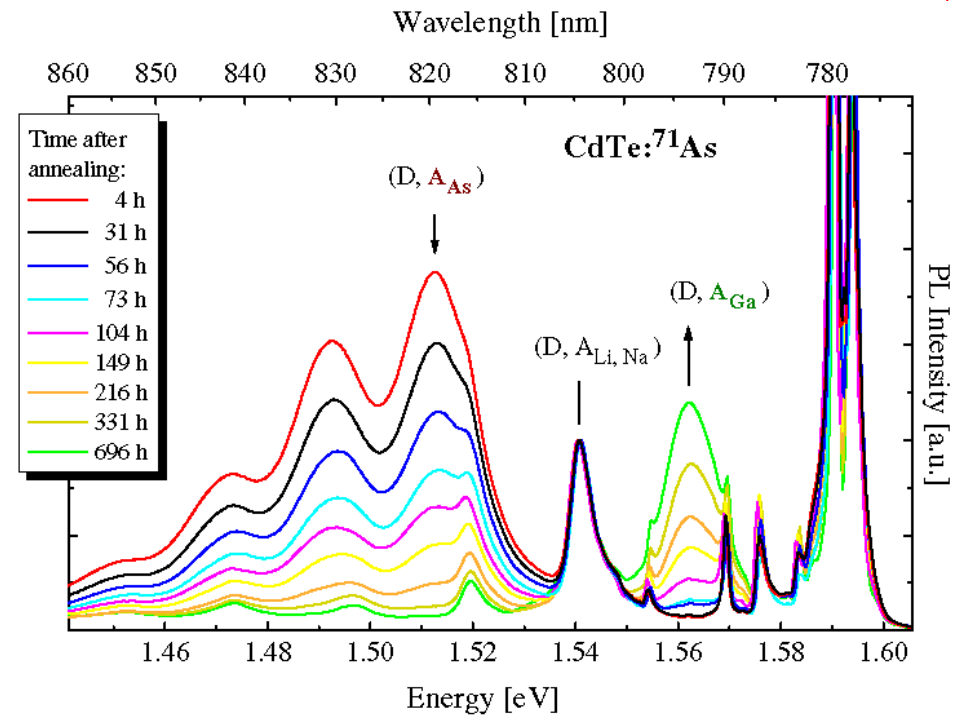

Summer students  
2005

Mats Lindro  
ISOLDE team



# MEDICAL PHYSICS

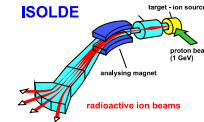

- Example: samarium isotopes
- “in vivo” dosimetry by positron emission tomography (PET)
- $^{142}\text{Sm}$  ( $\alpha$ ,  $T_{1/2} = 72\text{m}$ )  $\rightarrow$   $^{142}\text{Pm}$  ( $\beta$ ,  $T_{1/2} = 40\text{s}$ )
- Therapy:  $^{153}\text{Sm}$  ( $\beta^-$ ,  $T_{1/2} = 47\text{h}$ )

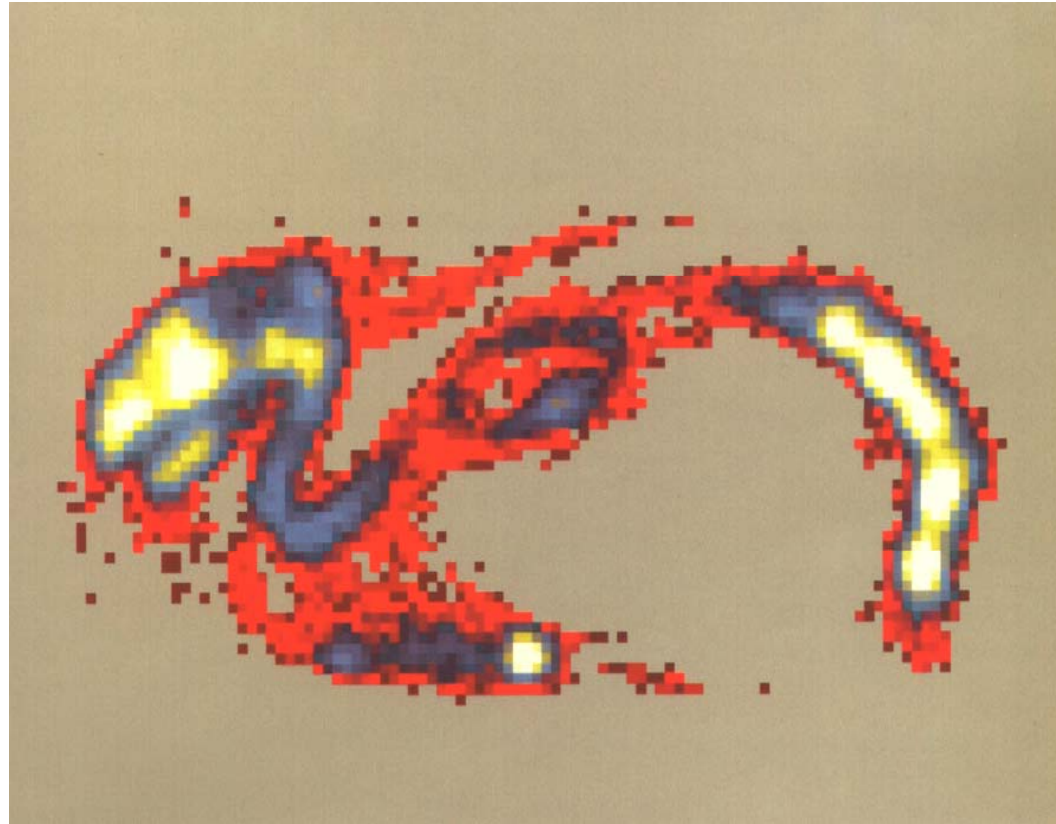

**PET scan of a rabbit 60 min p.i. of ISOLDE produced  $^{142}\text{Sm}$  in EDTMP solution**



# PRINCIPLE OF RADIOIMMUNO THERAPY

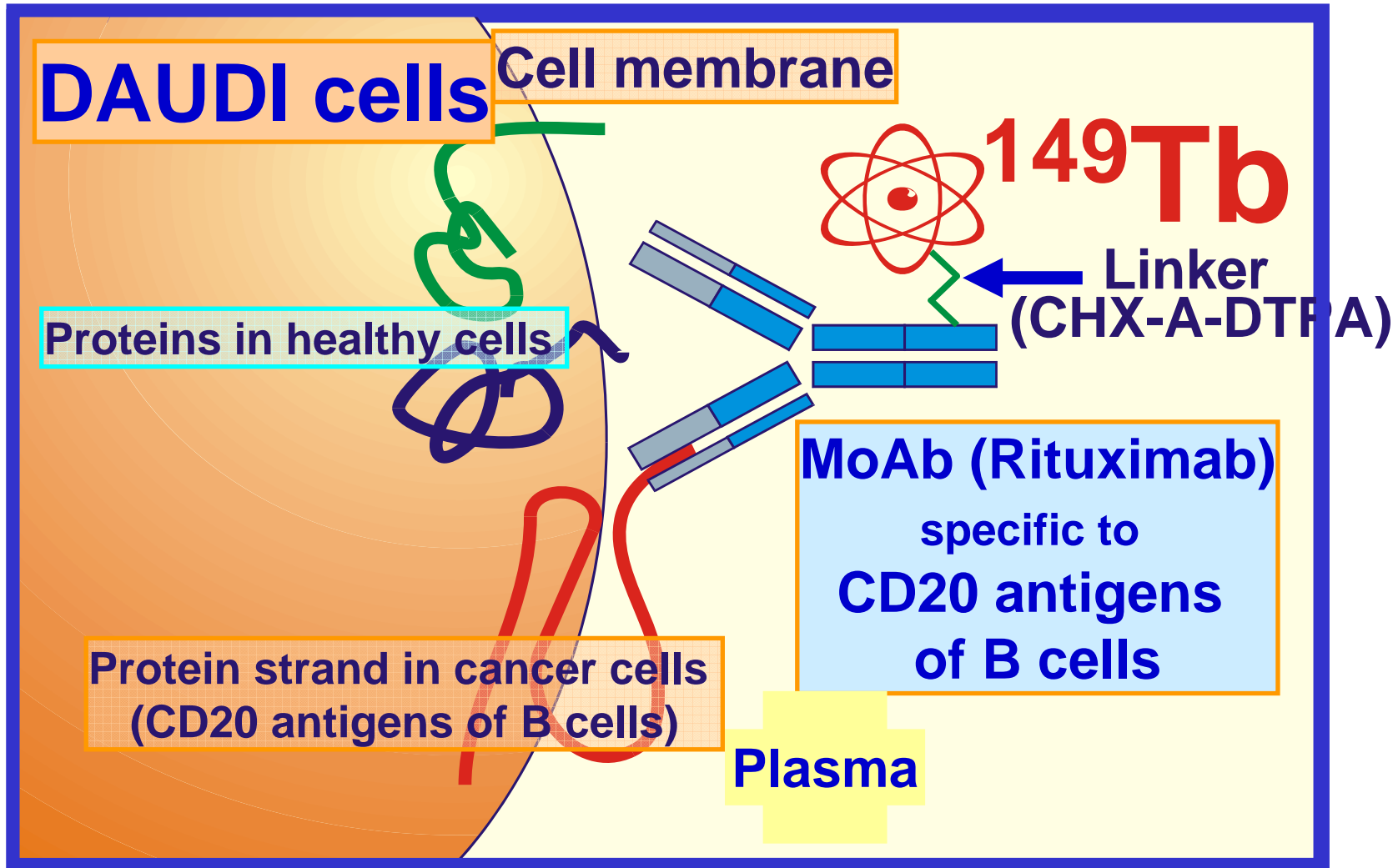
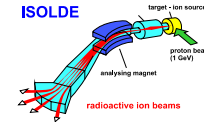





# POST ACCELERATION

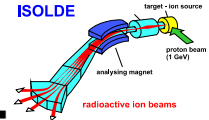

- Challenges when accelerating radioactive ions:
  - Low intensity
  - Short half lives
  - Charge state

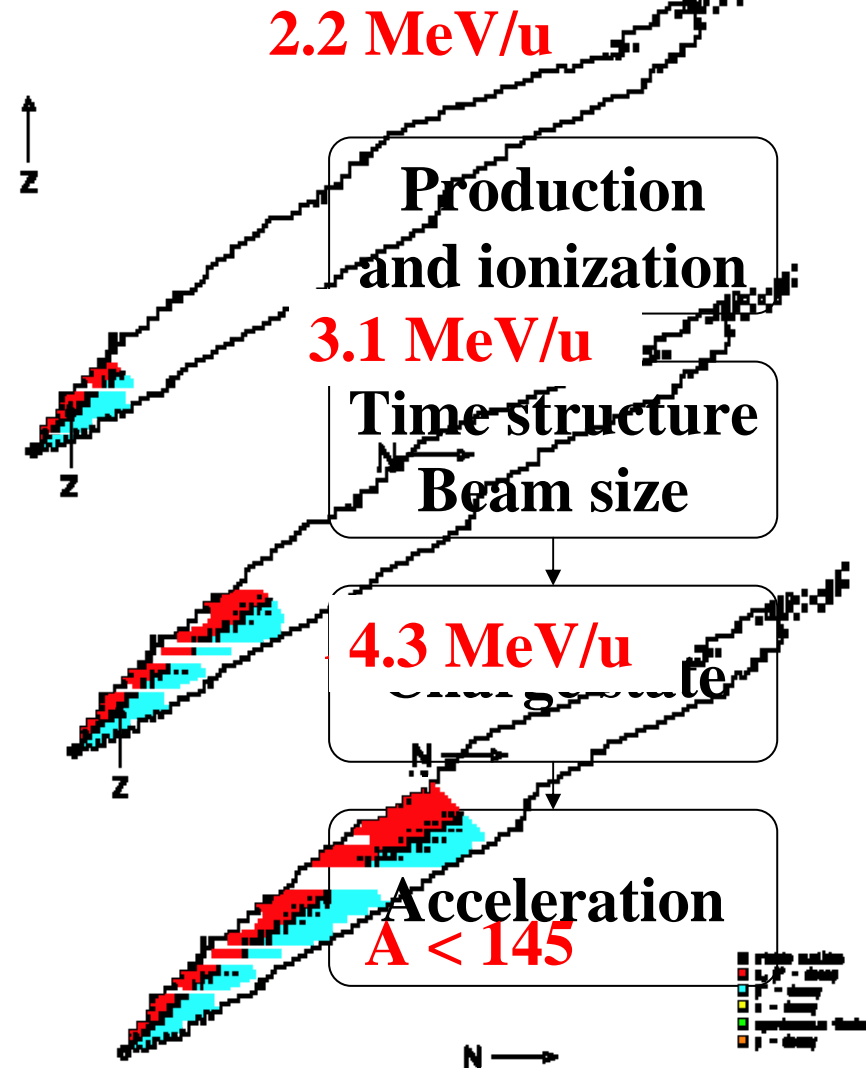



ISOLDE

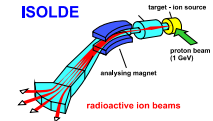

REX EBIS

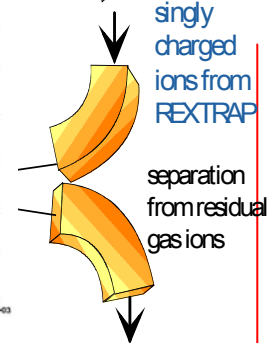
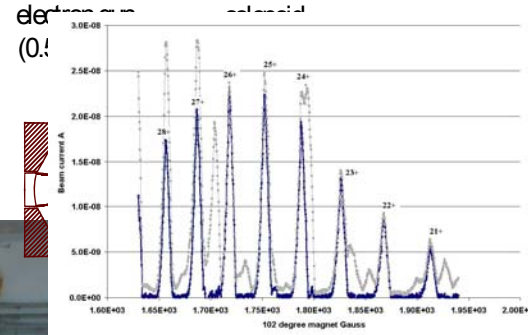
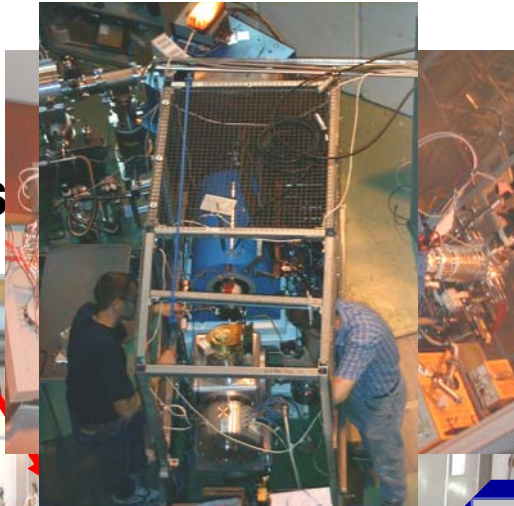

For A > ?:

IS 397 team

Charge breeding of Uranium and

$^{96}\text{Sr}^{15+}$ ,  $^{94}\text{Rb}^{15+}$



q/A-selector

REXTRAP

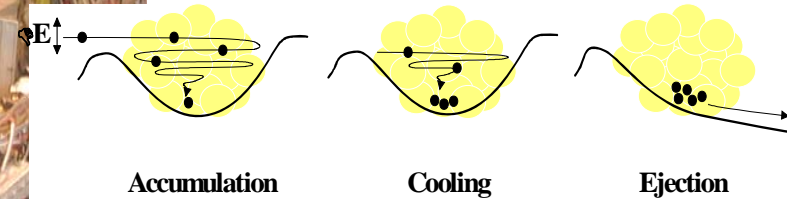

Summer students  
2005

Mats Lindroos on behalf of the  
ISOLDE team

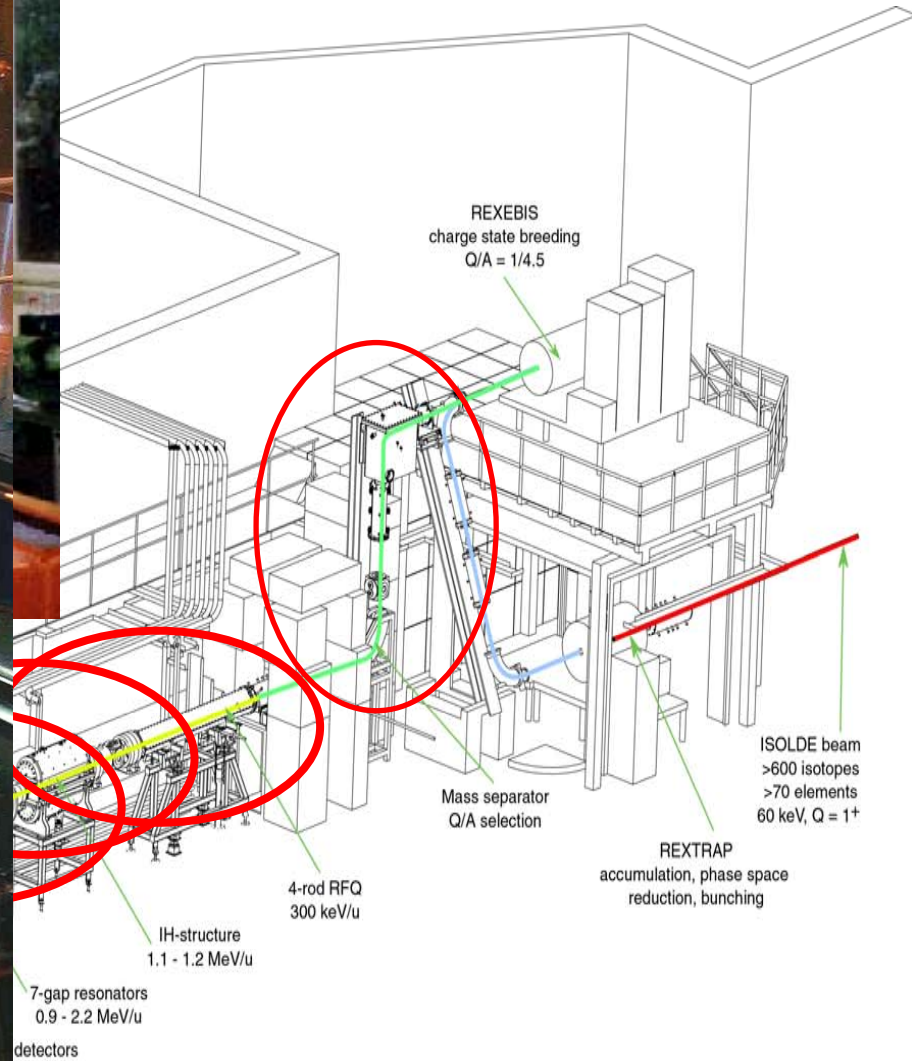
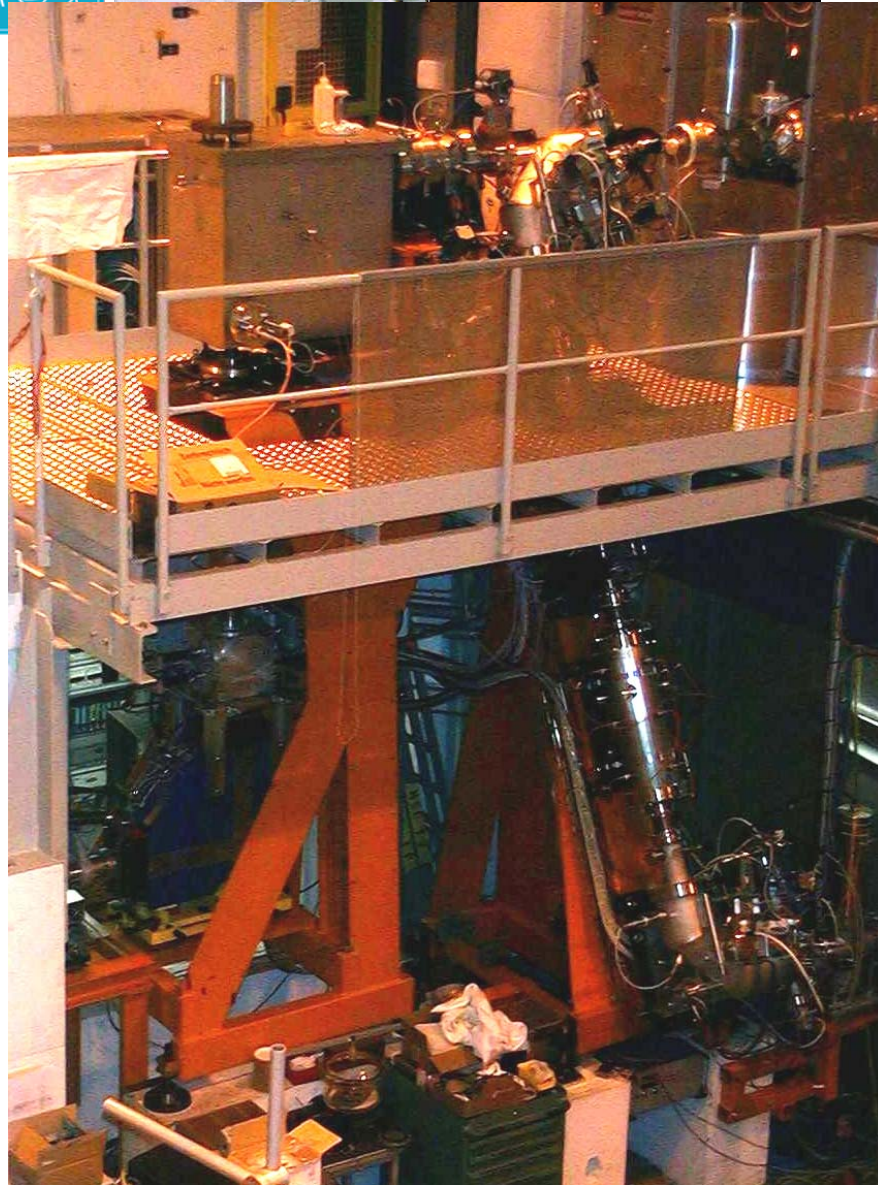
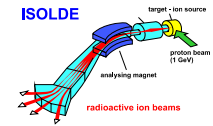

Summer  
2005

ISOLDE team



# REX MINI BALL

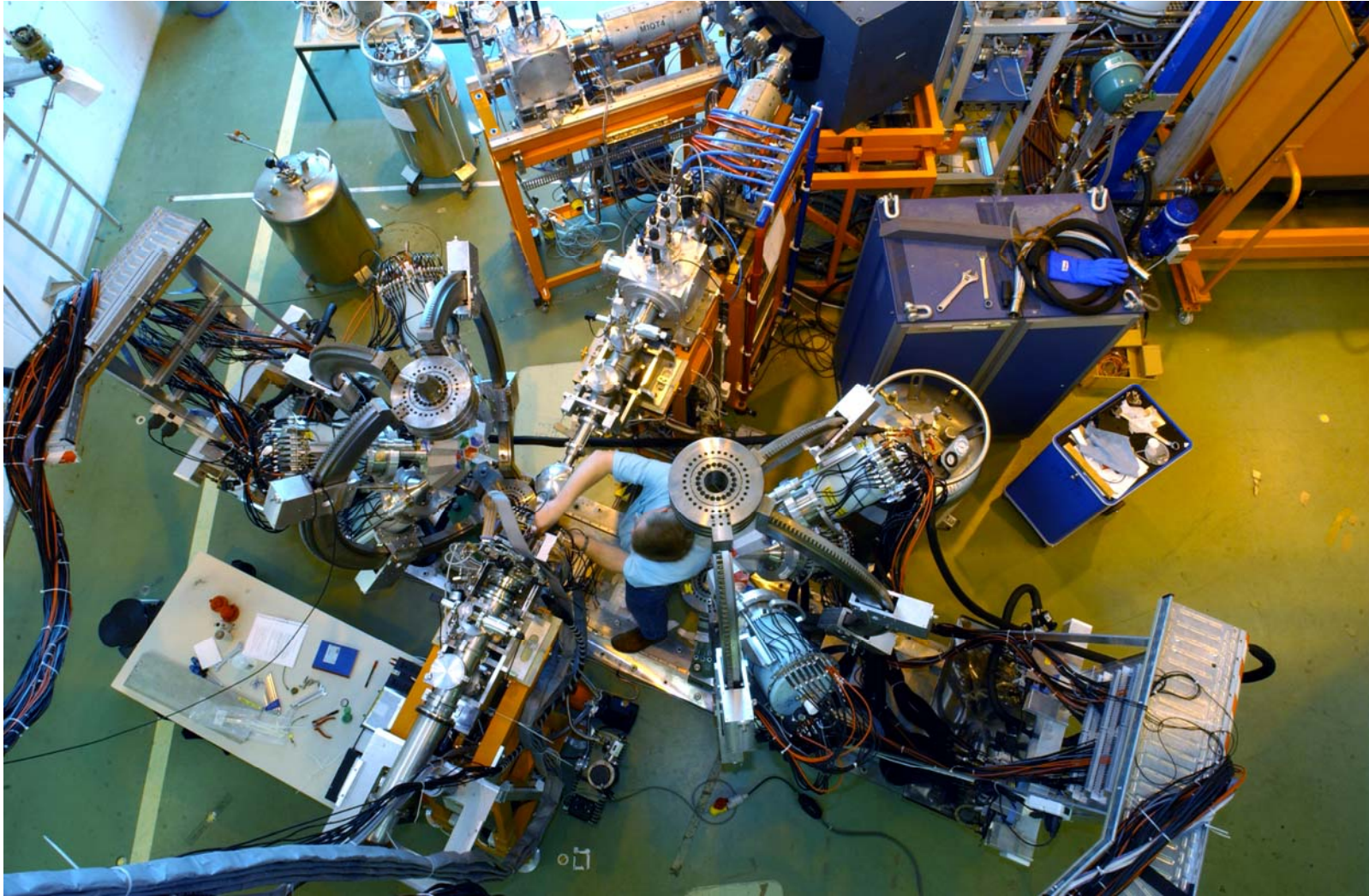
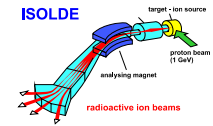

Summer students  
2005

Mats Lindroos on behalf of the  
ISOLDE team



# FUTURE PLANS MORE PROTONS: LINAC 4

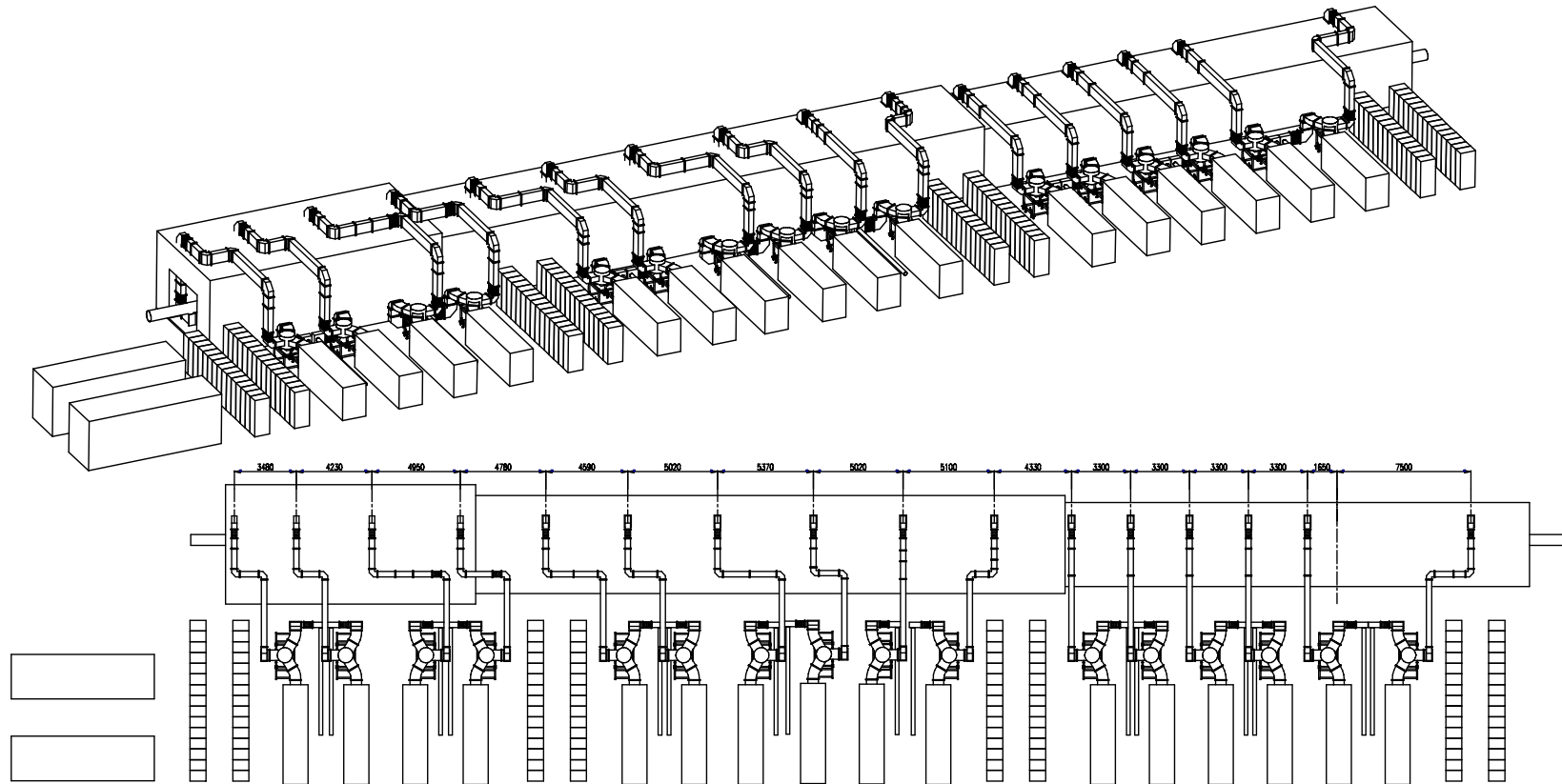
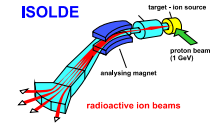

**From M. Vretenar**  
Summer students  
2005

Mats Lindroos on behalf of the  
ISOLDE team



# 900 MS CYCLING OF THE PS BOOSTER

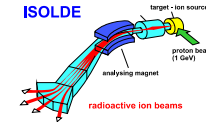

- Present PSB cycle 1.2 s
- Increase PSB capacity to cope with increased demands for protons at CERN
- Major proton users to benefit: LHC, ISOLDE, CNGS

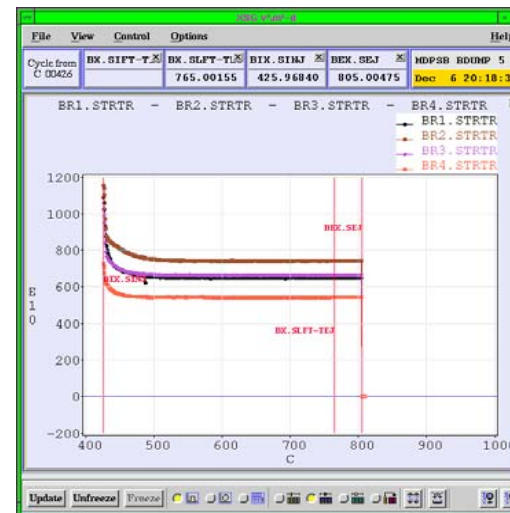
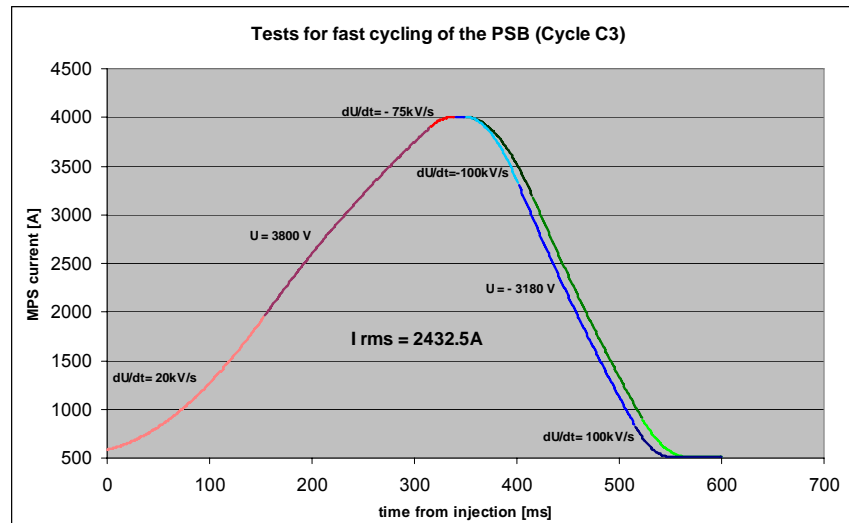

From M. Benedikt, AB, CERN

Summer students  
2005

Mats Lindroos on behalf of the  
ISOLDE team



# FUTURE PLANS THE SPL

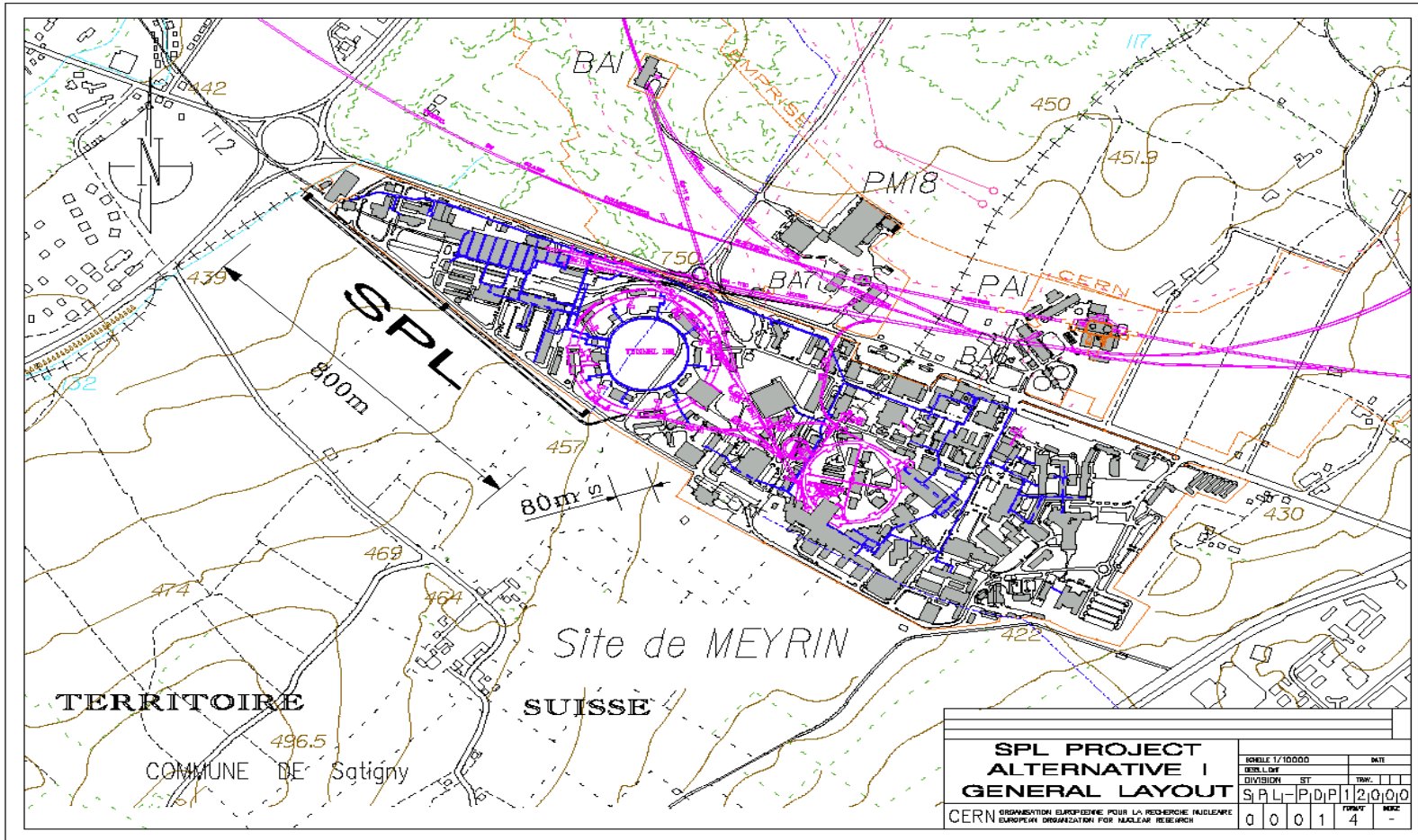
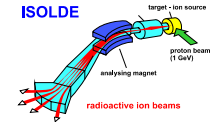

Summer students  
2005

Mats Lindroos on behalf of the  
ISOLDE team



# FUTURE PLANS

## A NEXT GENERATION RNB FACILITY

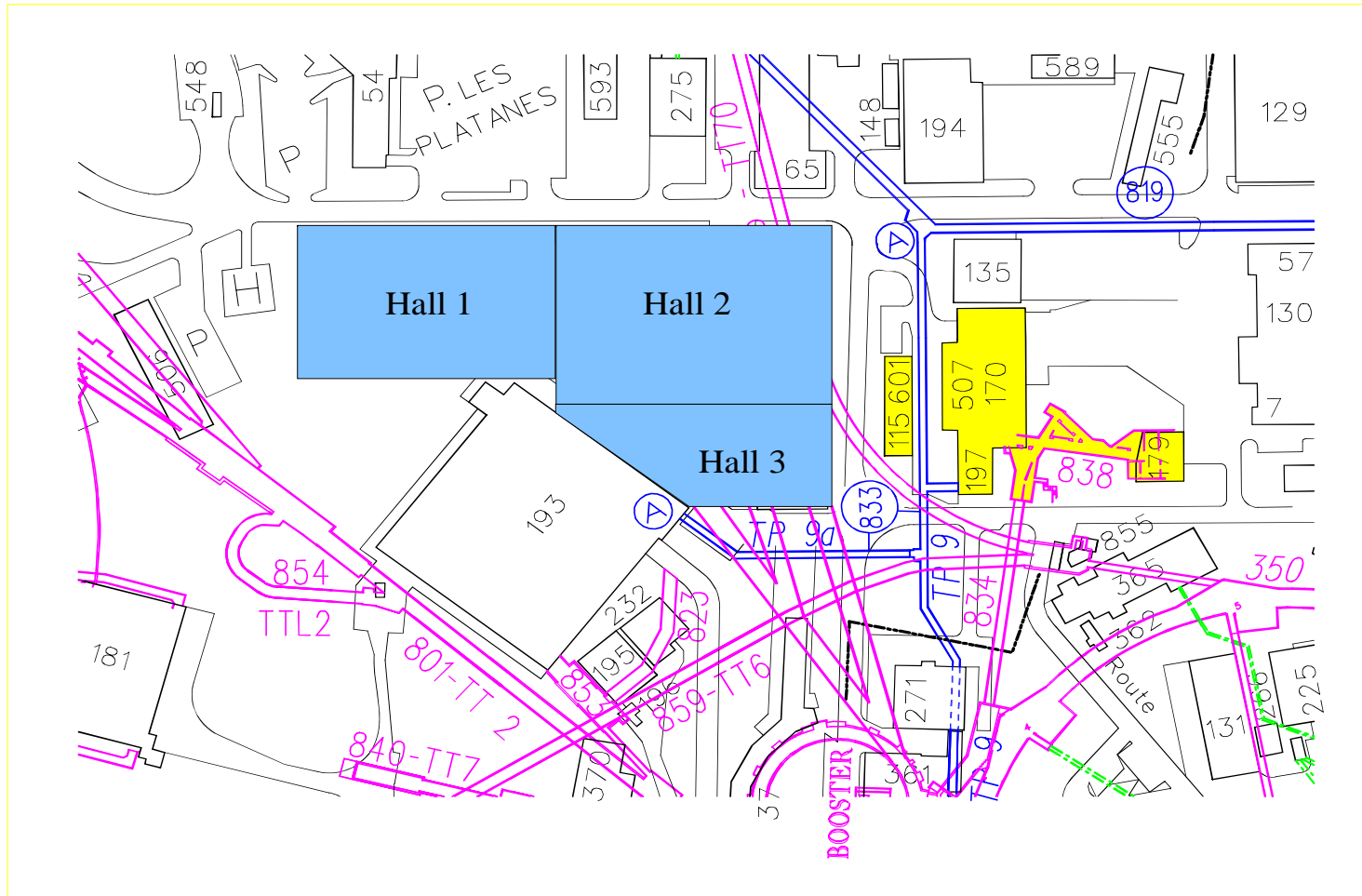
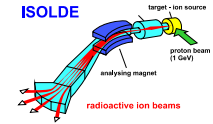

Summer students  
2005

Mats Lindroos on behalf of the  
ISOLDE team





EURISOL

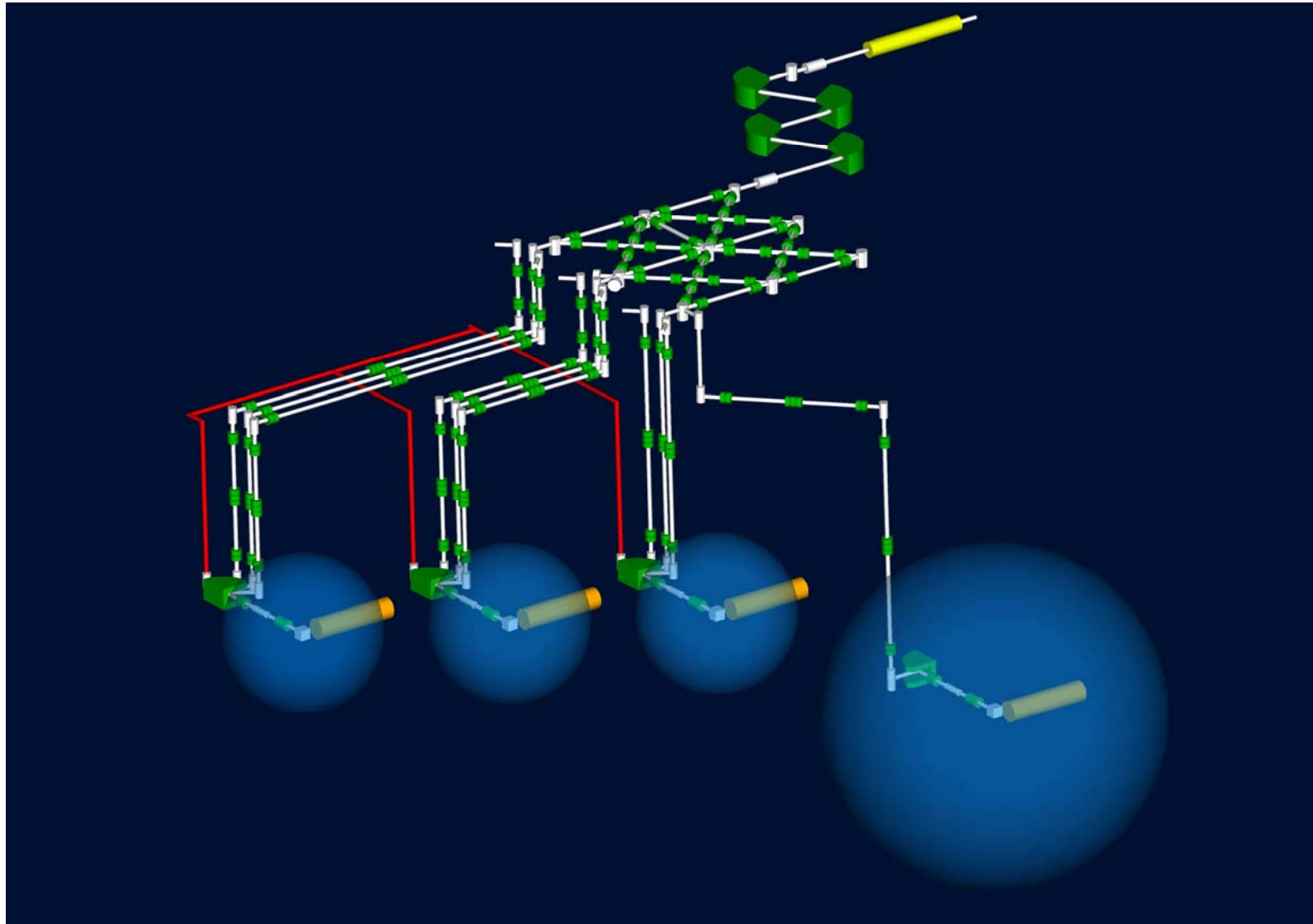
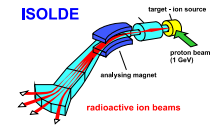

Summer students  
2005

Mats Lindroos on behalf of the  
ISOLDE team



# TARGET DEVELOPMENT

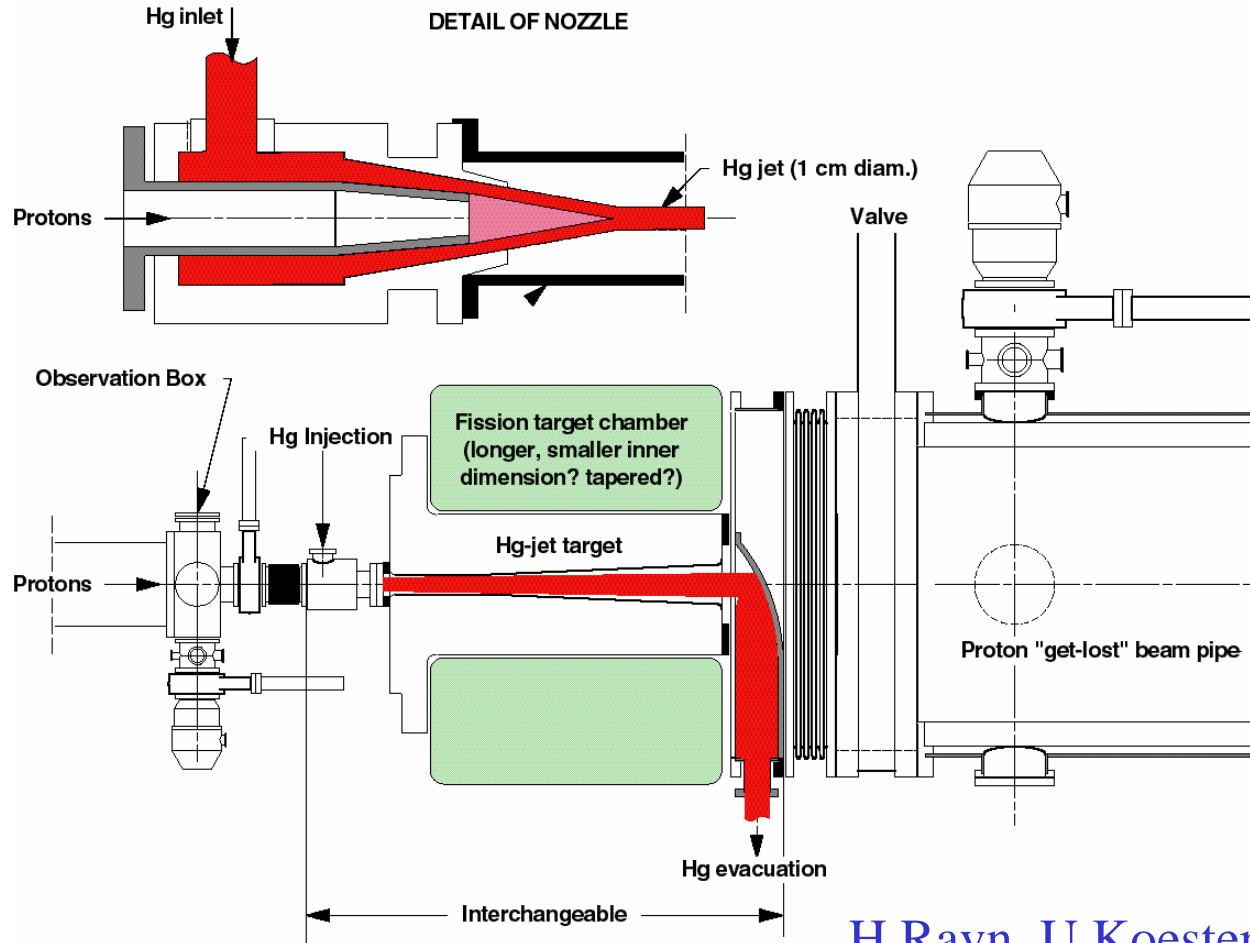
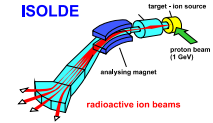

H.Ravn, U.Koester, J.Letry,  
S.Gardoni, A.Fabich

Summer students  
2005

Mats Lindroos on behalf of the  
ISOLDE team



# THE BETA-BEAM

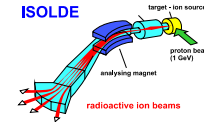

AIM: provide beams of electron (anti) neutrinos by decay of beta active ions.

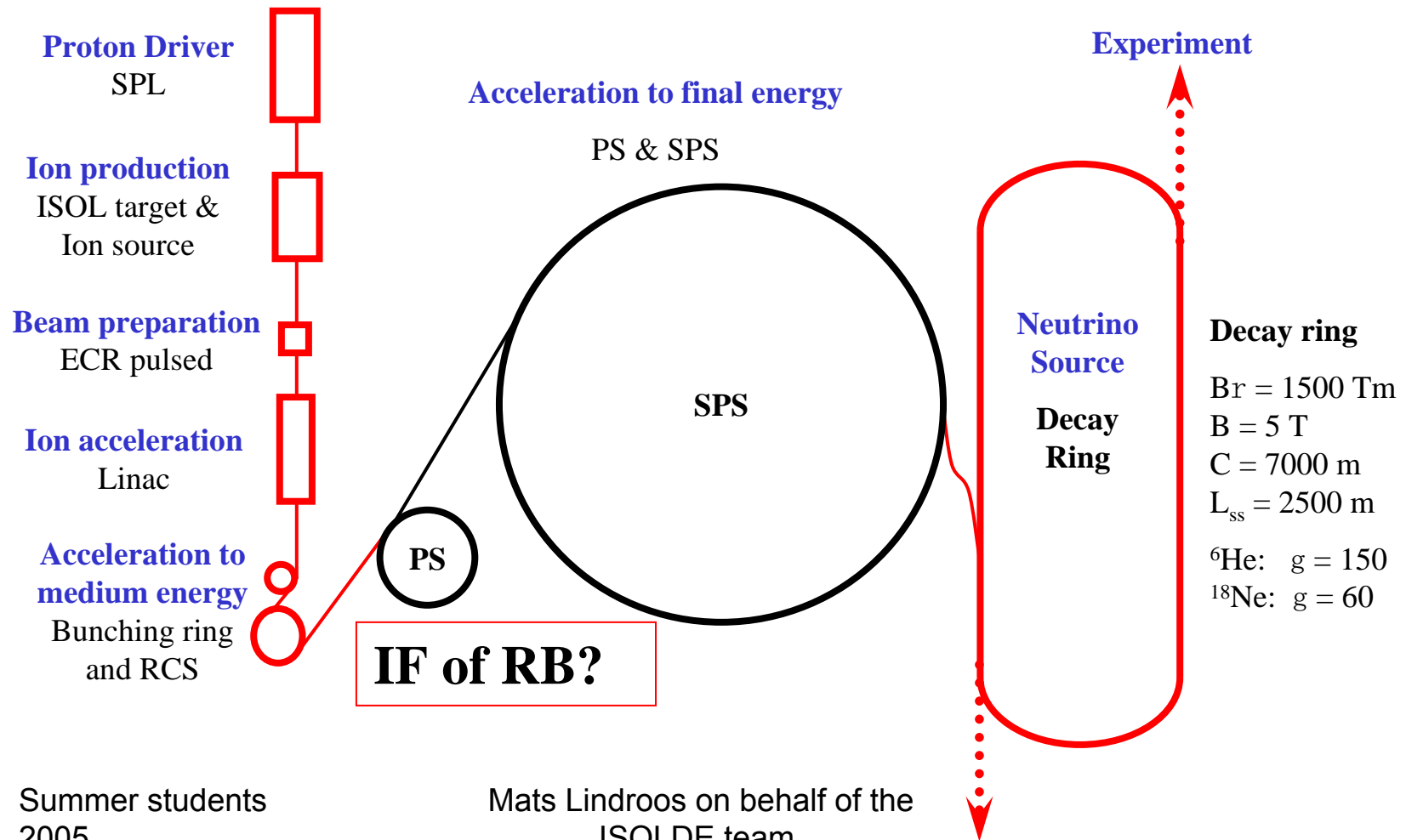



# CERN TO FREJUS

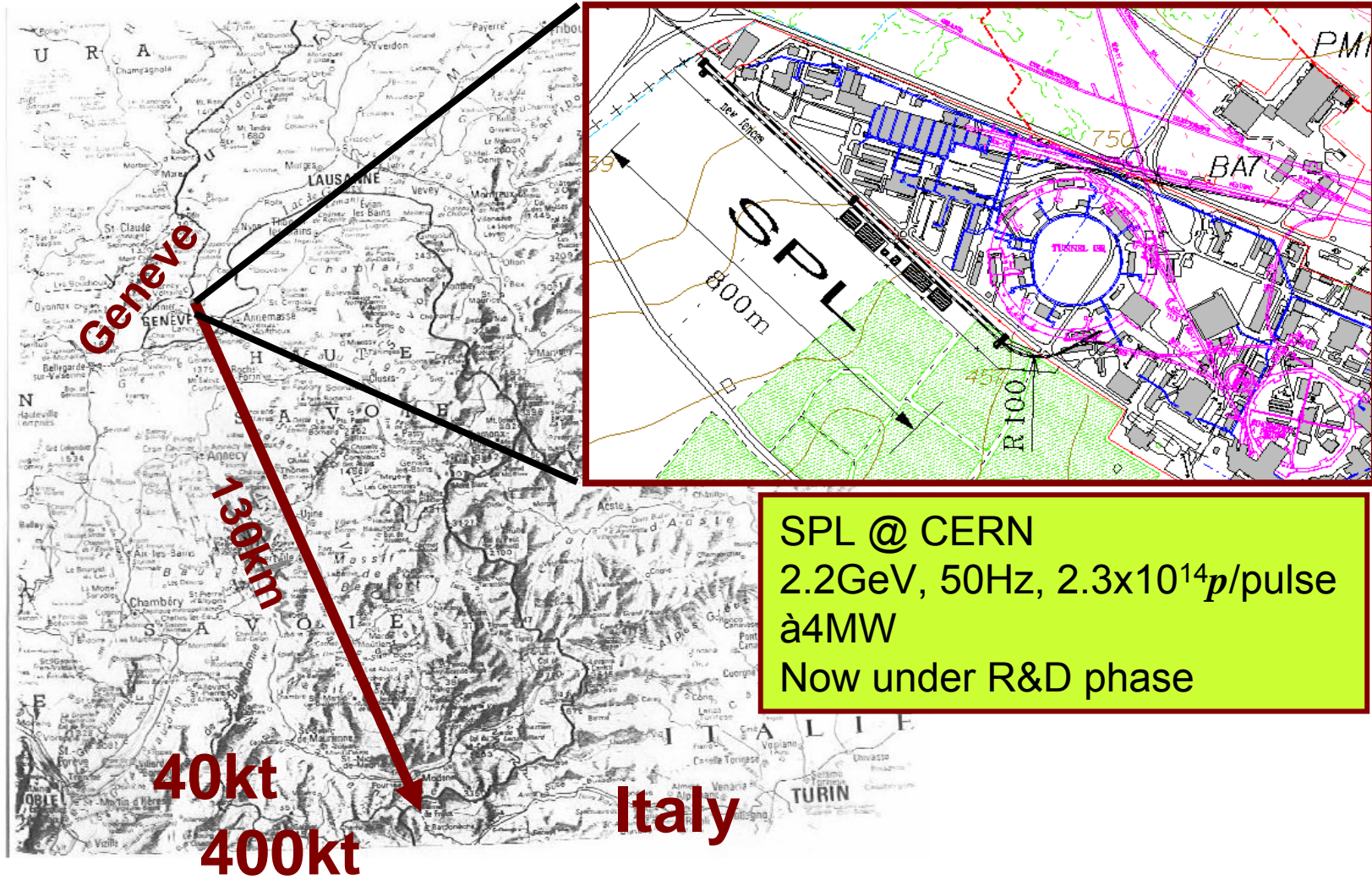
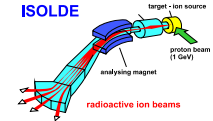

Summer students  
2005

Mats Lindroos on behalf of the  
ISOLDE team



# WATER CHERENKOW SUPER KAMIOKANDE

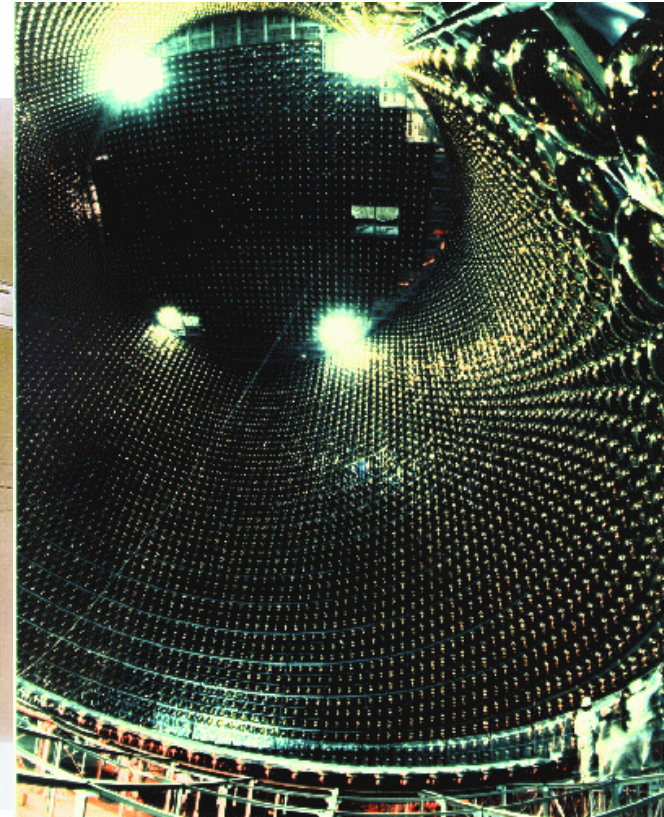
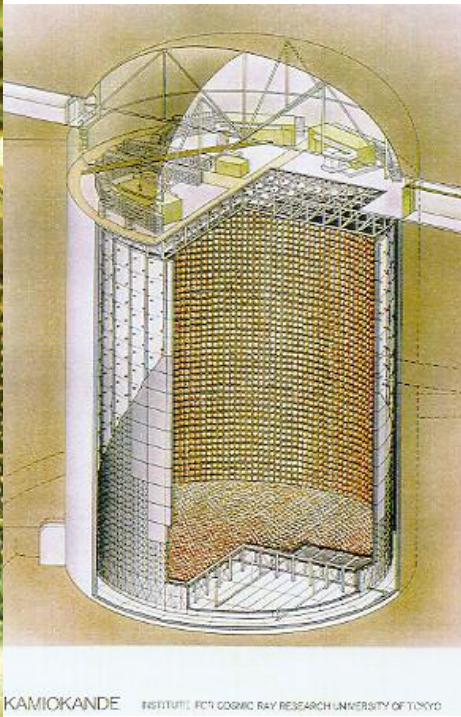
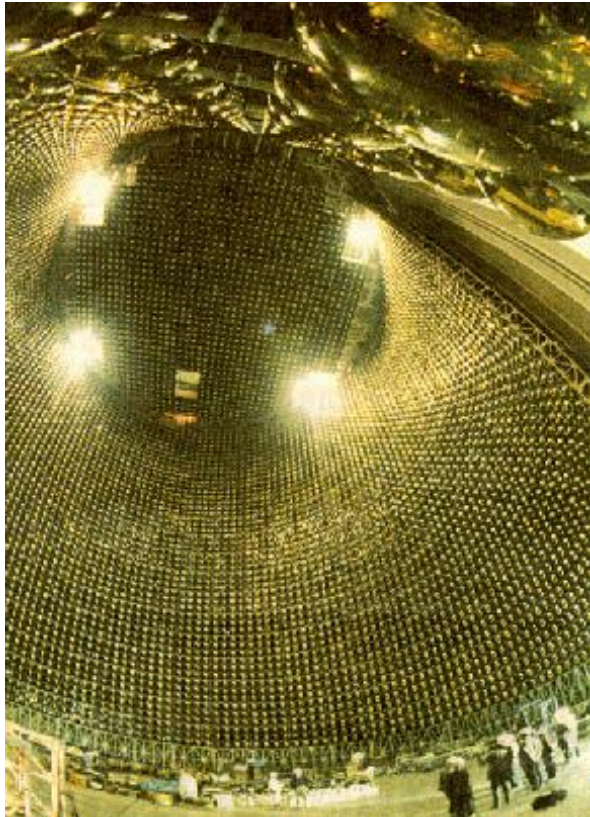
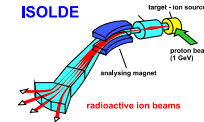

MultiUSER detector: Astrophysics, Beta-beam, Super Beam, Proton Decay

Summer students  
2005

Mats Lindroos on behalf of the  
ISOLDE team



# COMBINATION OF BETA BEAM WITH LOW ENERGY SUPER BEAM

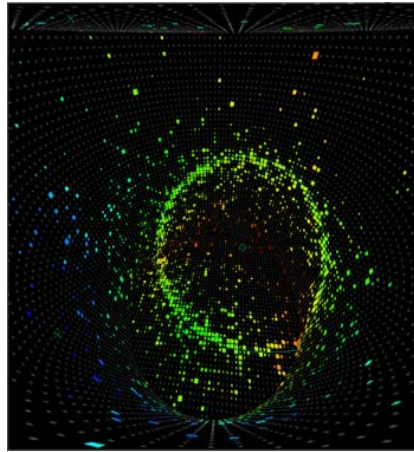
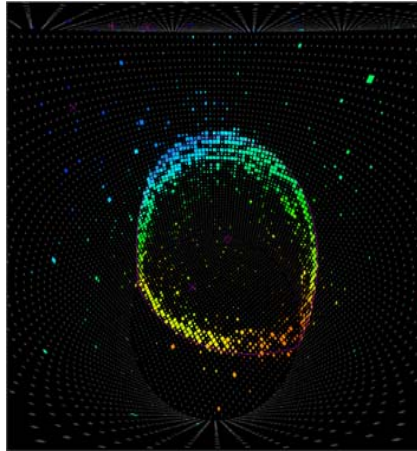
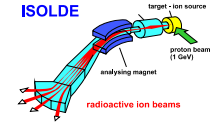

Unique to CERN:

combines CP and T violation tests

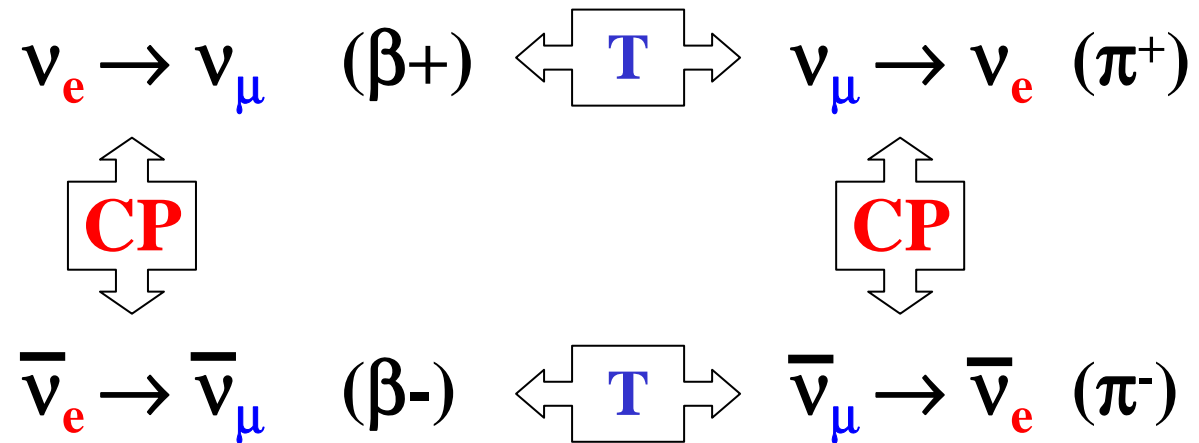

A. Blondel

Summer students  
2005

Mats Lindroos on behalf of the  
ISOLDE team



## CONCLUSIONS

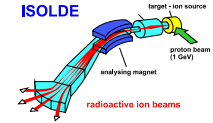

- Nuclear physics and its applications:
  - are fascinating subjects
  - have an exciting future at new large scale facilities
  - holds exciting research opportunities for you; for a Ph.D. and a future research career
- Thank you for your attention!



# ISOLDE VISIT

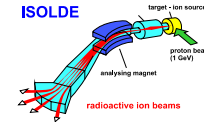

- Today at 15.00!
- Bring your filmbadge
- We are meeting outside the ISOLDE hall (Building 170)

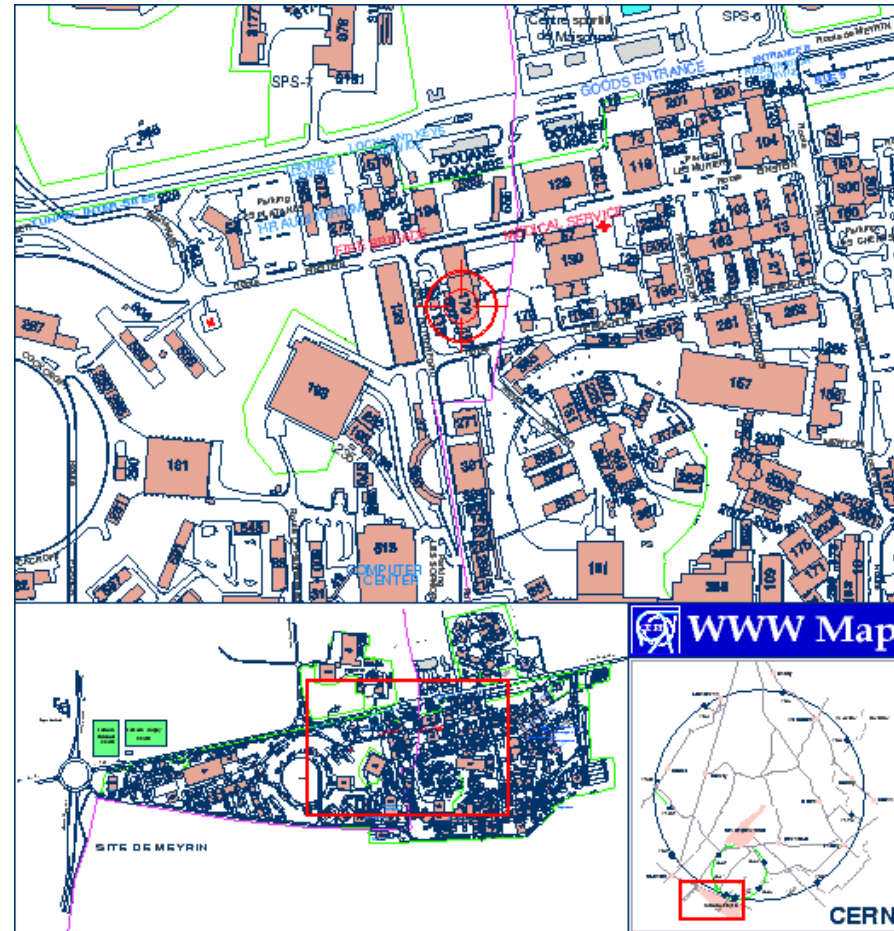

Summer students  
2005

Mats Lindroos on behalf of the  
ISOLDE team





# ISOLDE VISIT

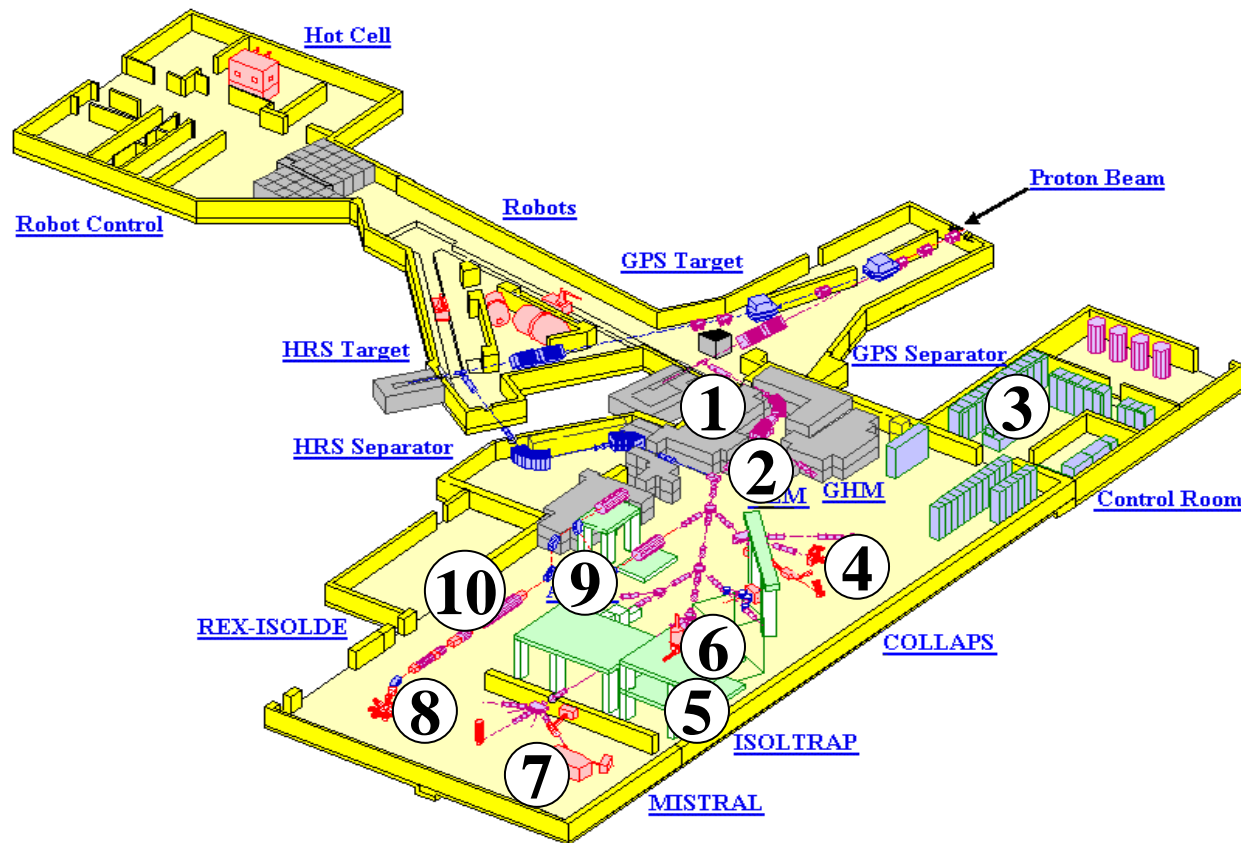
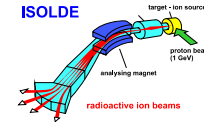

1. RILIS
2. Collections (medical physics, solid state physics)
3. Control room and targets
4. COLLAPS, COMPLIS and Tilted foil
5. ISOLDE Posters
6. ISOLTRAP
7. MISTRAL and NICOLE
8. MINI-BALL
9. ASPIC
10. REX

Summer students  
2005

Mats Lindroos on behalf of the  
ISOLDE team