



NGS

National Grid Service

101010001000000100100

101010001000000100100

?

@

1010100010000001

Security Issues

Jens Jensen

Oxford GridPP/NGS day

24 Oct 2008



NGS

- Authentication to NGS
 - UK e-Science Certification Authority
 - SARoNGS (see next slide)



SARoNGS

- Shibboleth Access to Resources on the National Grid Service
- JISC-funded project
- Collaboration between STFC, Manchester, Oxford
- Include access to MIMAS

Architecture

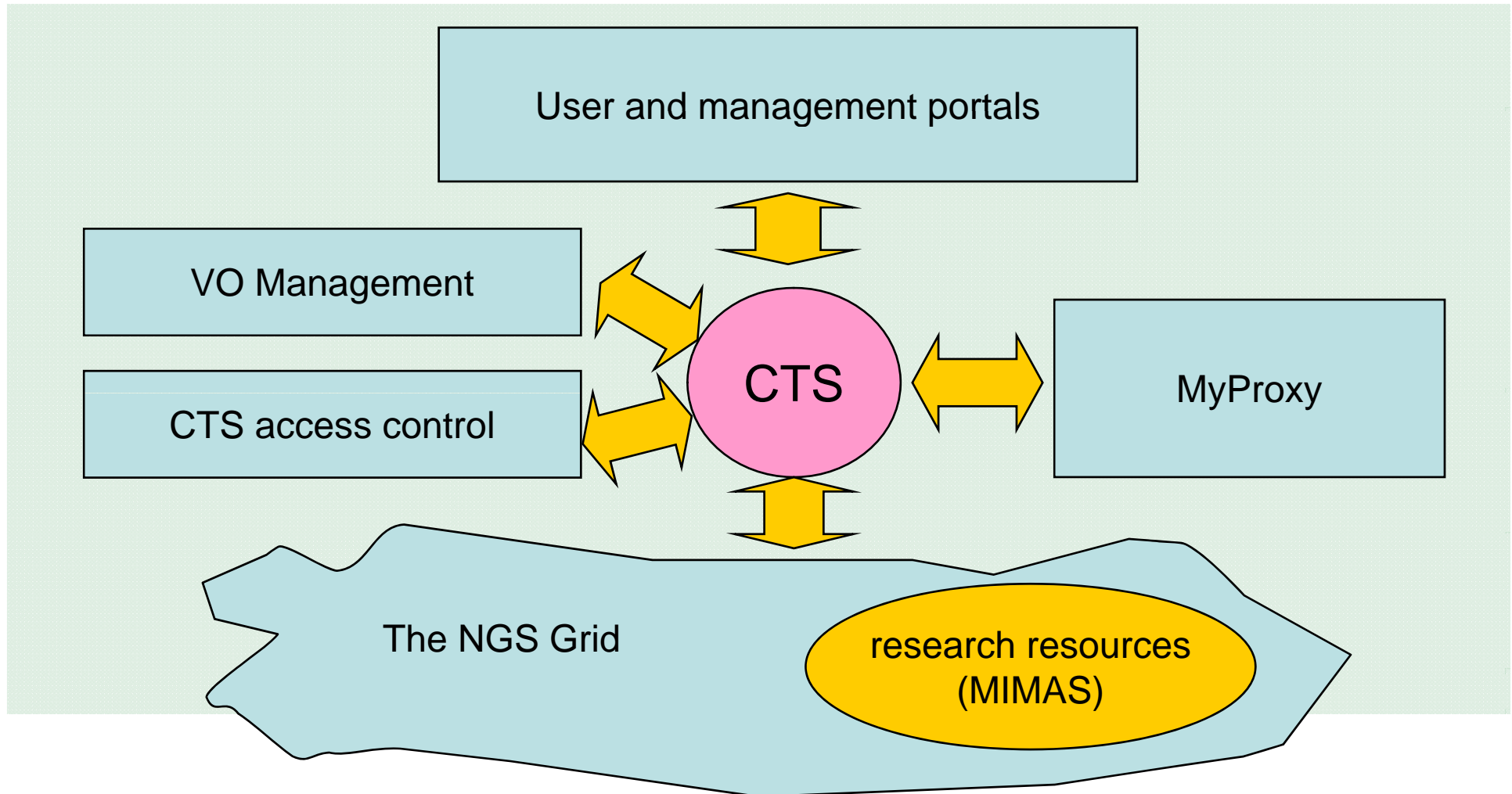

More detailed Arch.

Another CA under the root

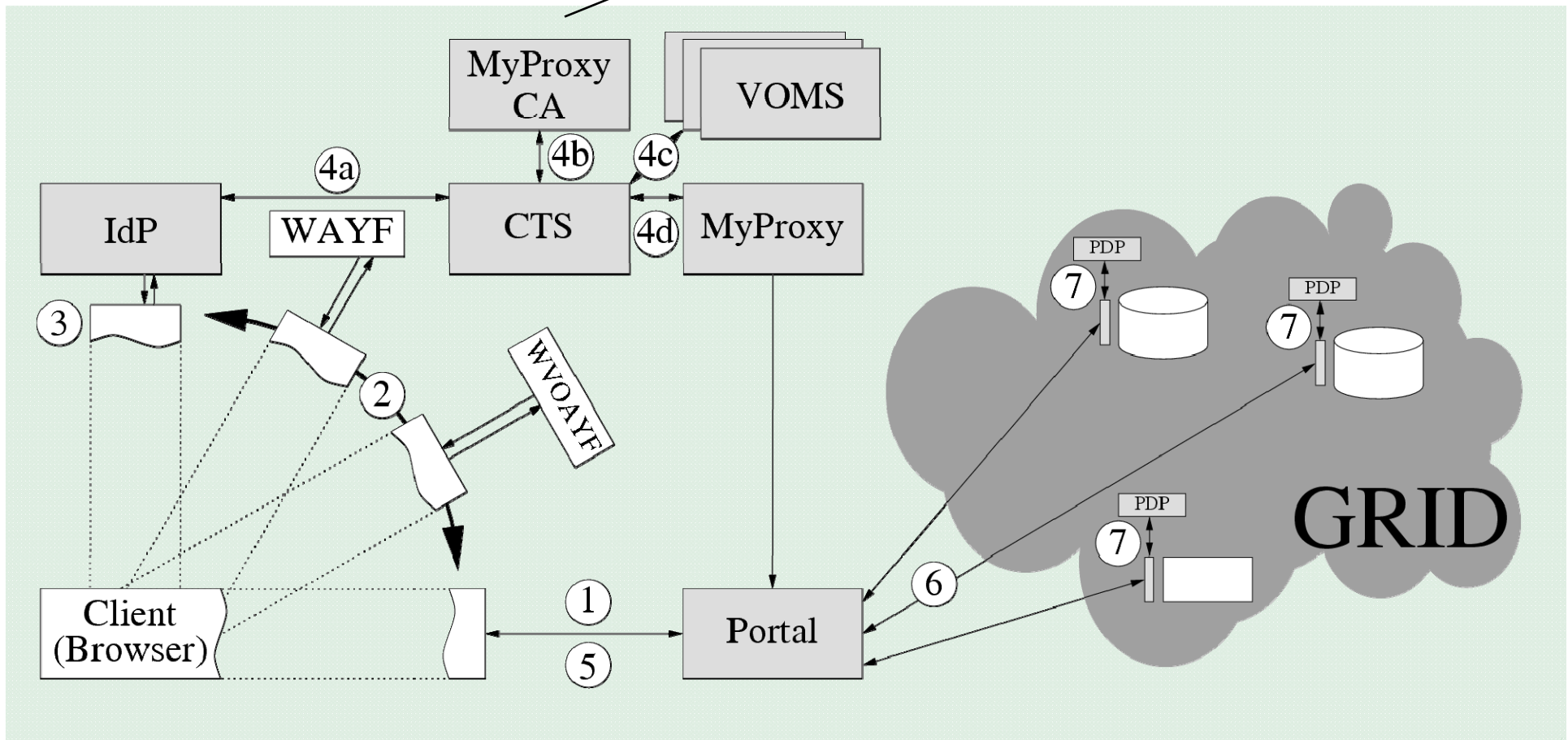



Scope

- Users authenticate *to NGS* via SARoNGS
 - Anonymised! – restricted by Fed
 - Large number of users – 10^{**5} (potentially)
- Users authenticate to WLCG via CA
 - IGTF-blessed
- CA also authenticates hosts
- GridPP also contribute to wider CA work

CA Thermodynamics

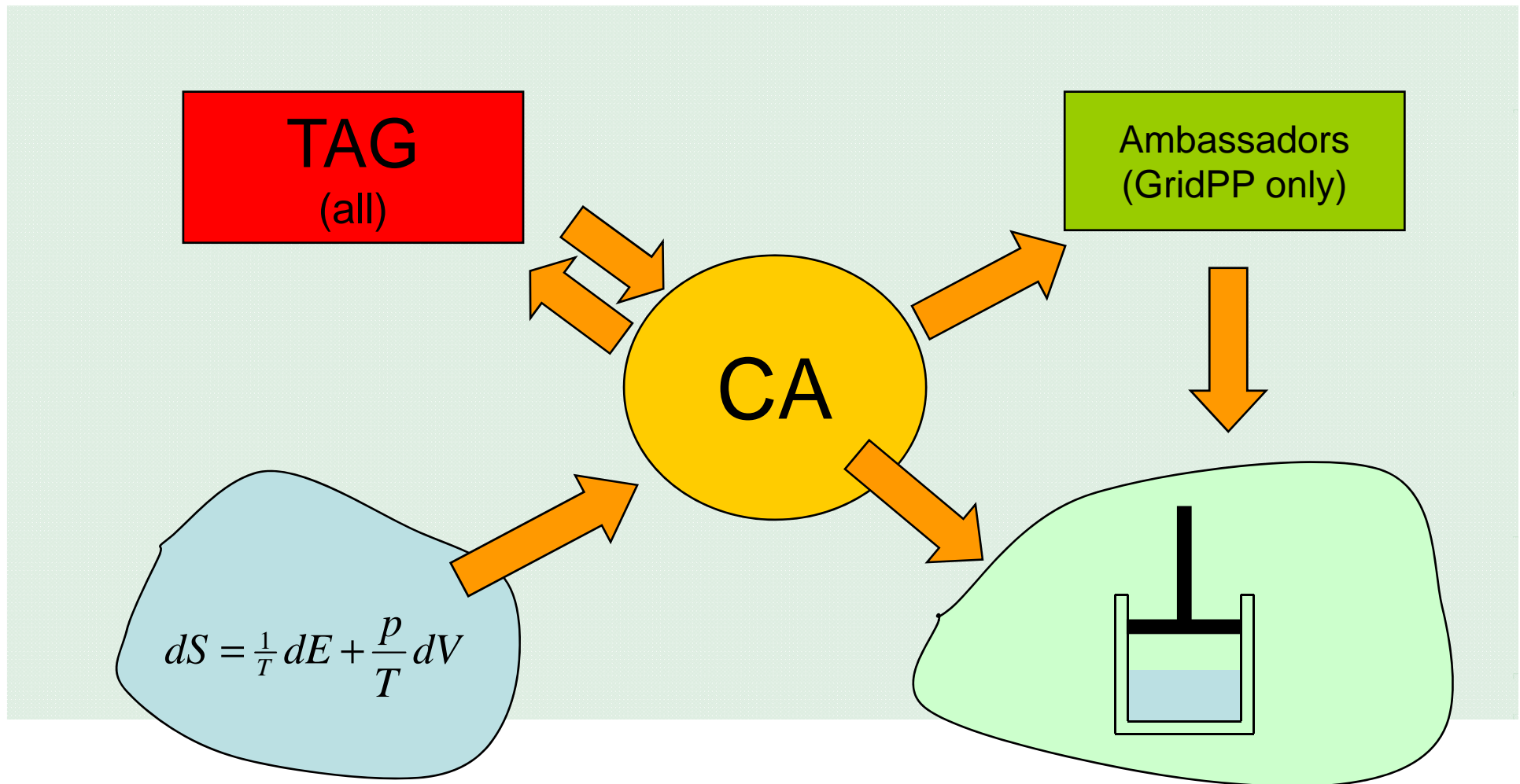



NGS-TAG-CA members

- NGS
- GridPP
- OMII-UK
- WLCG
- OSG (NCSA)
- EGEE??

Issues

- Secured comms
 - Key generation
 - Key distribution
 - Using keys
- Needs ToIR
- Personal representation
- Some overlap



Incident Response

- NGS-SECURITY mailing list
 - Connected to JANET CSIRT?
- Incidents are often at OS level
 - Below grid middleware
 - Thus common to both Grids
- Low overlap in AuZ (currently)
 - Except for VOs trusted on both sides



Suggestions

- We seem to be doing OK at the moment
- Look at incident response
 - Share information
 - Limit on need to know?
 - Security considerations
 - Or avoid swamping sites with info
- Ponder NGS→NGI (EGI security)