

# **Status of R&D of the ANKOK project: Low mass WIMP search using double phase argon detector**

Masashi Tanaka for the ANKOK Collaboration  
Waseda University, Japan

38<sup>th</sup> Internal Conference on High Energy Physics (ICHEP2016)  
August 5<sup>th</sup> 2016 Chicago

# Outline

- ANKOK Project
  - Double Phase Liquid Argon Detector
  - Physics Goal
- Status of R& D
  - Waseda Liquid Argon Test stand
  - New Optical Readout Device
  - Detailed Understanding of Liquid Argon
- Future Plan
  - 30 kg Detector Design/Construction
  - Surface Run @Waseda
  - Underground Run @Kamioka
- Summary

# ANKOK Group

- Waseda University, Japan
  - 2 physicists
  - 10 grad. students

2/15



# Double Phase Noble-Liquid TPC Detector (Ar, Xe)

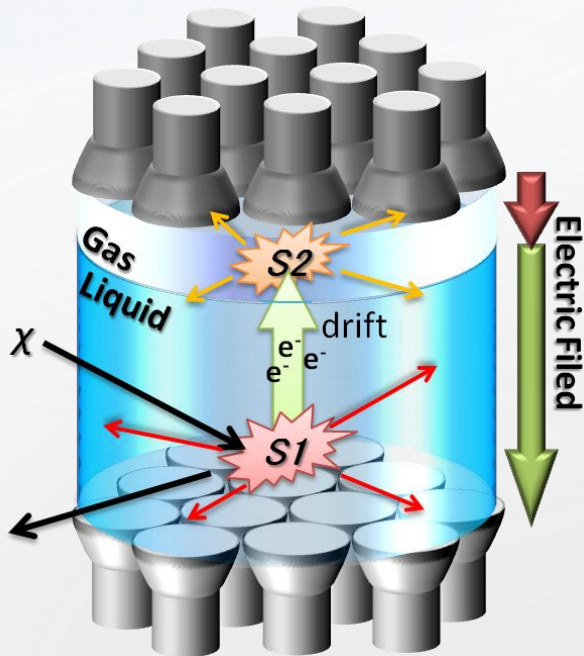

|                              | He    | Ar   | Xe  | Water |
|------------------------------|-------|------|-----|-------|
| Boiling point (K)            | 4.2   | 87   | 165 | 373   |
| Density (g/cm <sup>3</sup> ) | 0.125 | 1.4  | 3.0 | 1     |
| Radiation length (cm)        | 755   | 13   | 2.8 | 36    |
| Scintillation (γ/keV)        | 20    | 40   | 42  | -     |
| Scintillation λ (nm)         | 80    | 128  | 175 | -     |
| Price (yen/L liquid)         | 2000  | 1000 | 1M  | 100   |

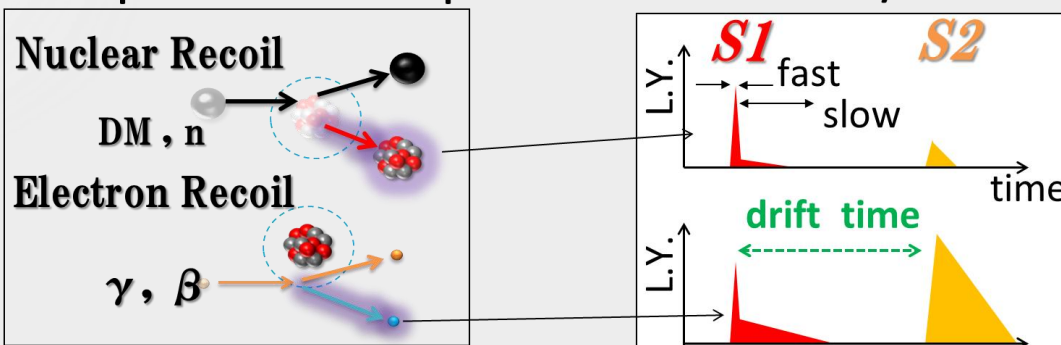

- Xe:
  - Heavy (better self shield)
  - Expensive
- Ar:
  - Better S1 PSD
  - 128 nm (need WLS)
  - <sup>39</sup>Ar (β decay): 1 Bq/kg

# Summary of Experimental Results

## ~Double Phase Detectors ~

- "DAMA region"
  - $\sim 10 \text{ GeV}/c^2$ ,  $10^{-40\sim 41} \text{ cm}^2$
- Xe detectors
  - XENON, LUX, PandaX
  - reject whole DAMA region
  - $\sim 5 \text{ keV}_{nr}$  threshold
- Ar detectors
  - WARP, Darkside
  - NO sensitivity to DAMA region
  - $\sim 40 \text{ keV}_{nr}$  threshold
  - Darkside (2015): Underground argon ( $^{39}\text{Ar}$  x 1/100)

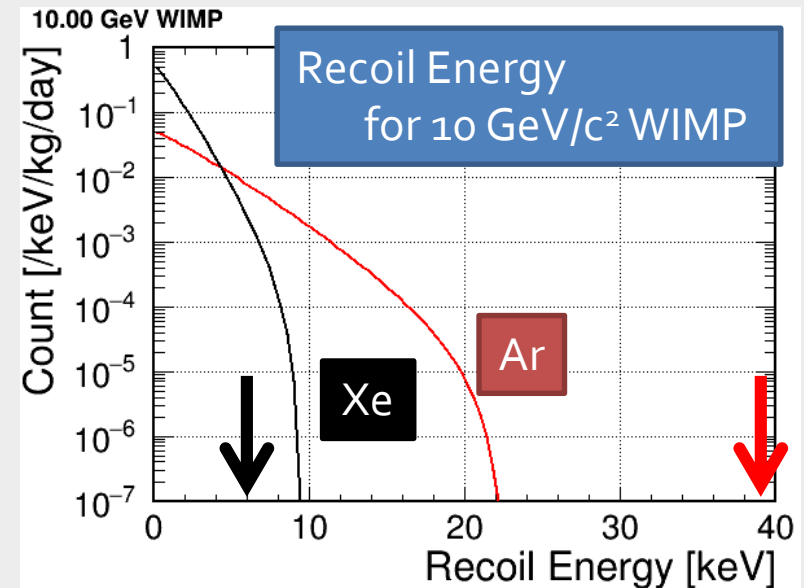
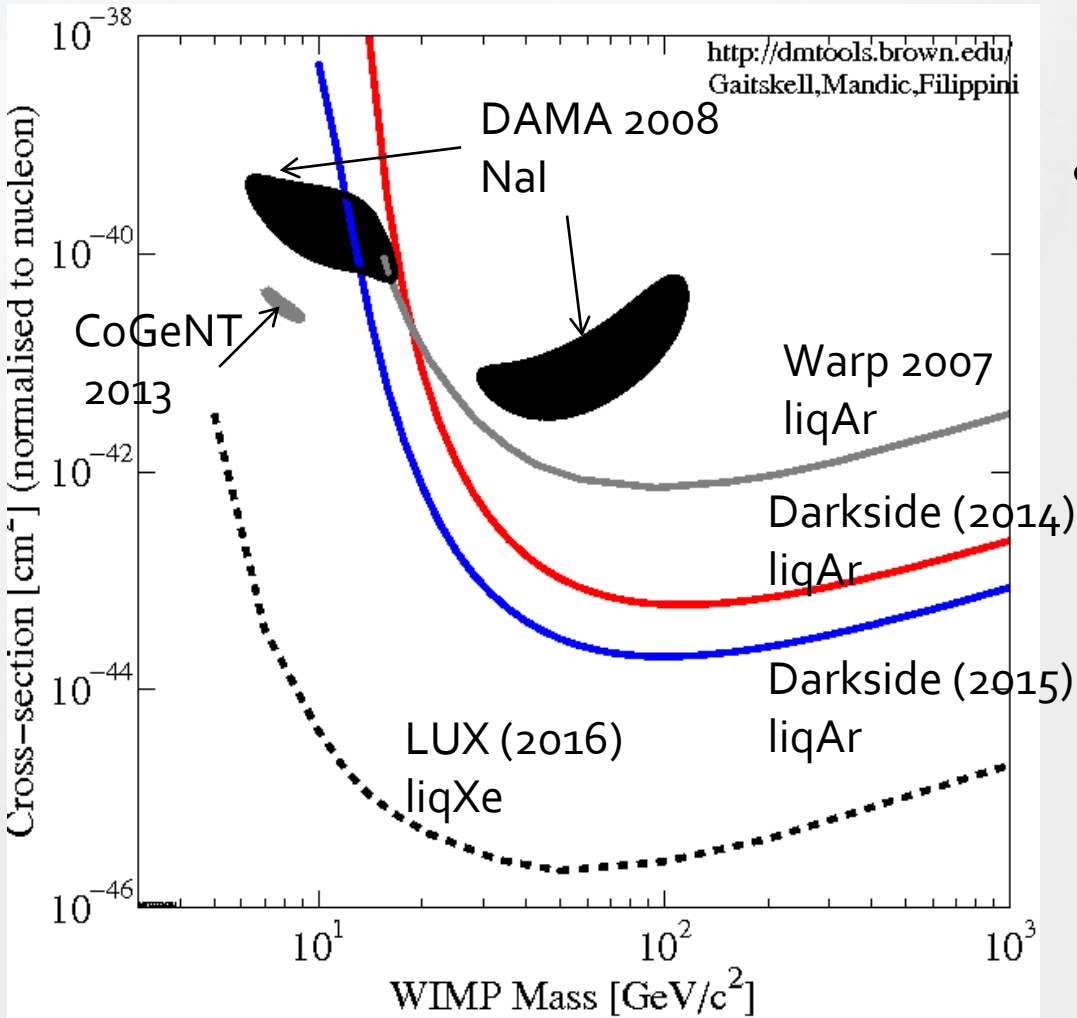

# Physics Goal and R&D Target of ANKOK

- Construct double phase argon TPC detector which is sensitive to DAMA region WIMP signal
  - ~50 kg detector with lower energy threshold
- Crucial R&D topics
  - New technique to improve background reduction
  - Detailed understanding of the liquid argon response at low energy ( bellow  $40 \text{ keV}_{nr}$ )
  - Understanding of the background sources
    - Environmental, internal, ...

# Waseda Liquid Argon Teststand

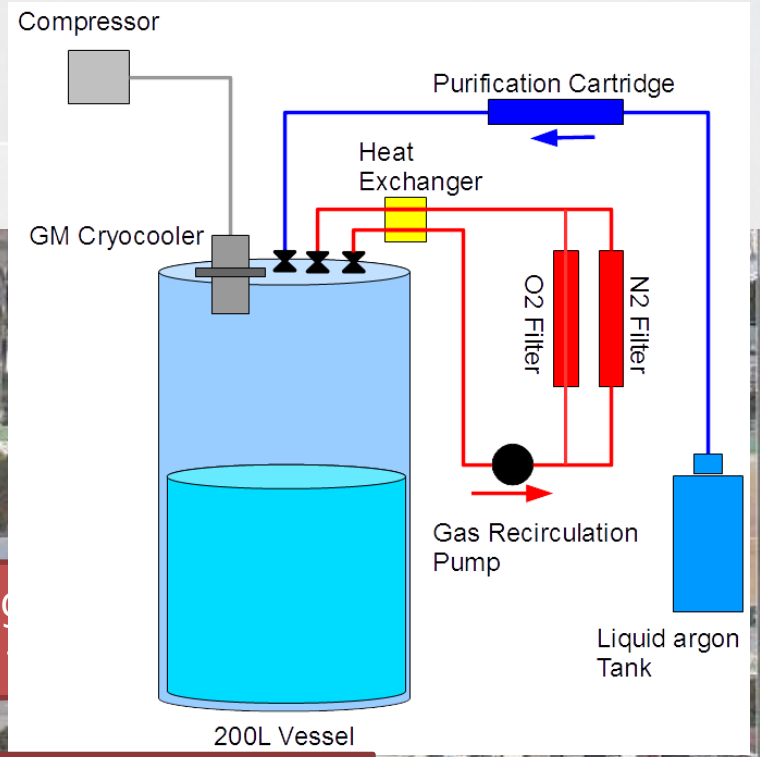

- 200L ( $\phi 500\text{mm} \times H1000\text{mm}$ ) Cryostat
- 200W GM cryocooler (Sumitomo)
- LAr filling through cryogenic filter
- Gas recirculation
- ~1 month of stable operation
- Achieved liquid argon purity
  - $\text{O}_2, \text{H}_2\text{O}: \sim 0.3 \text{ ppb}$
  - $\text{N}_2 < 100 \text{ ppb}$
- 0.5 mm liquid surface control



Sea



画像 ©2013 Google, ZENRIS

# ANKOK Project

Apr. 2012

2013

R&D with 75L Vessel ( $\phi 300$ )

1 kg prototype detector

Single Phase

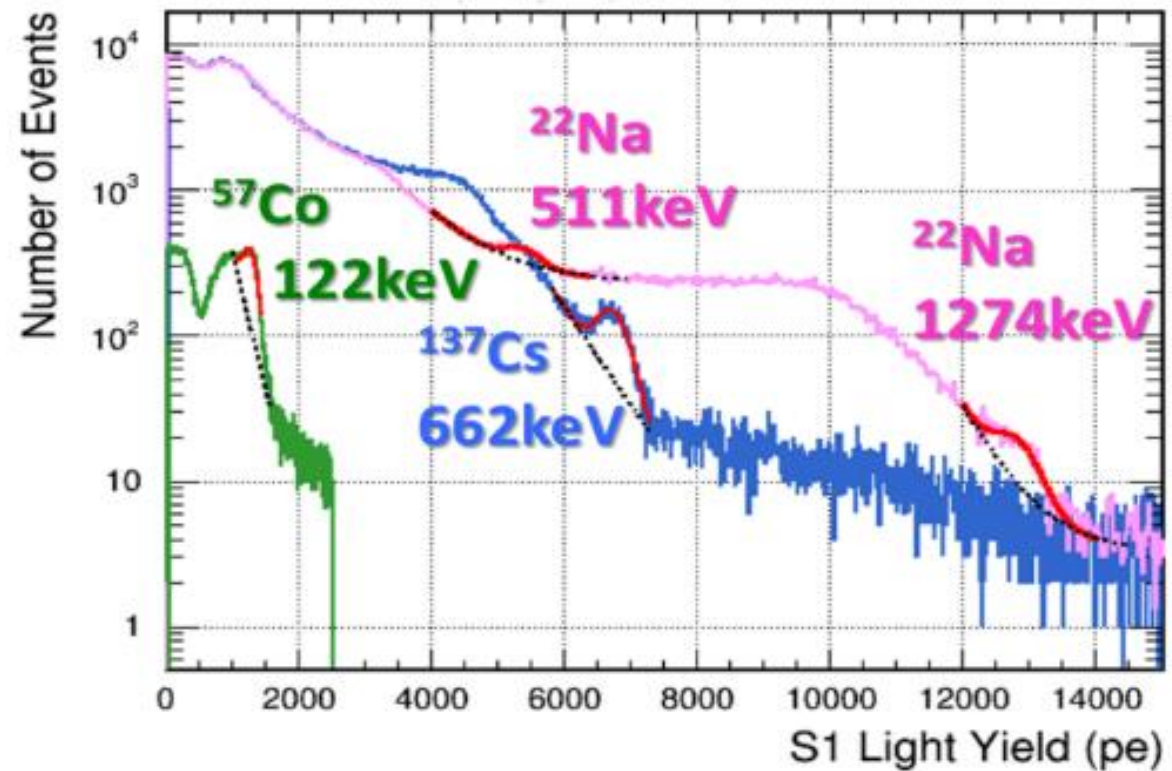

30 kg Detector



Apr. 2012  
Project start

Mar. 2013  
Establish stable operation of Liquid Argon with good purity ( $< 0.3$  ppb  $O_2$ )

Oct. 2014  
Establish highest level of LAr light detection yield ( $\sim 10$  pes/keVee)

Direct detection of LAr light using VUV MPPC ( $\alpha$ -source)

Detailed studies with Prototype 2-Phase detector

# VUV MPPC

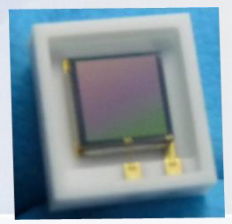

- VUV MPPC: (SiPM)
  - Developed by Hamamatsu
  - Direct sensitivity to 128 nm
  - chip size: 3 mmx 3 mm
  - pixel pitch : 50/100 um

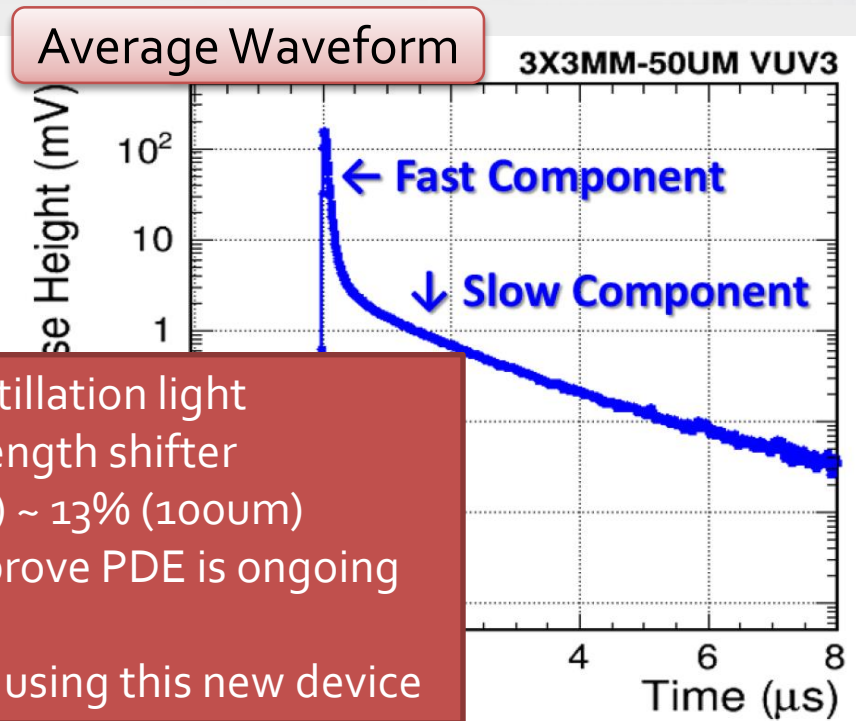
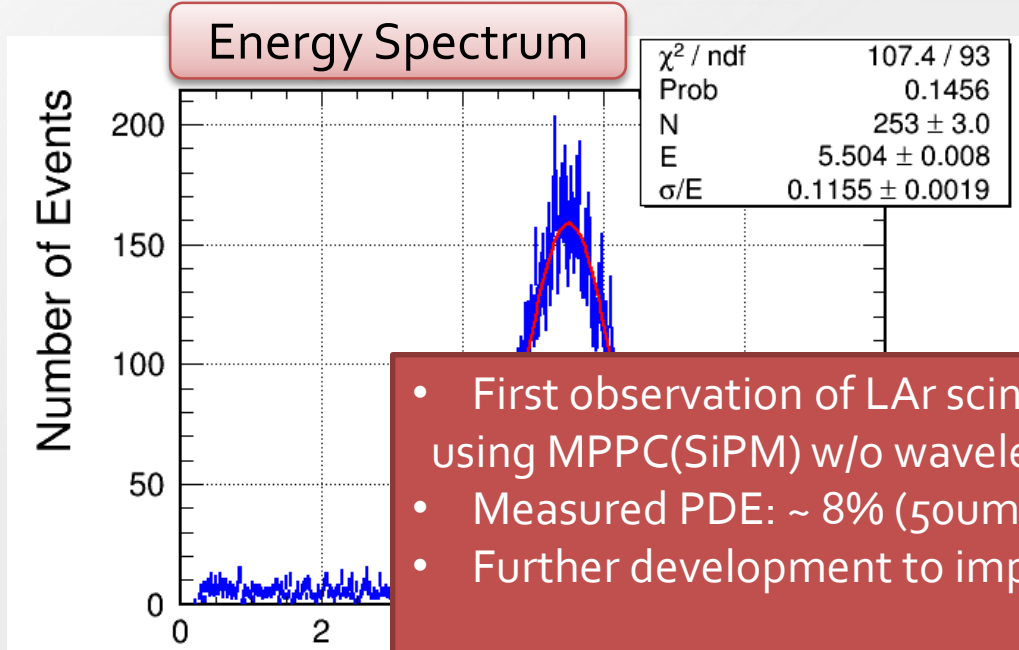
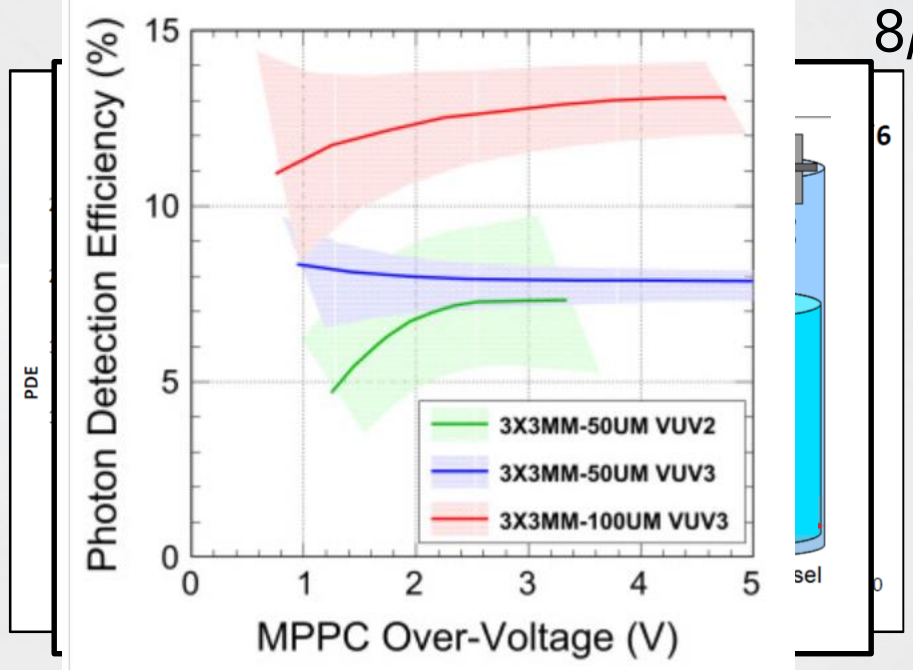

• First observation of LAr scintillation light using MPPC(SiPM) w/o wavelength shifter  
 • Measured PDE: ~ 8% (50um) ~ 13% (100um)  
 • Further development to improve PDE is ongoing  
 Improve detector performance using this new device

# 1 kg Prototype Double Phase Detector in 2015

9/15

- Fiducial: ~0.5 kg
- 3(top) + 3(bottom) PMTs  
– HAMAMATSU R11065
- 4MPPCs at Liquid surface wall
- Drift E: 200~1000 V/cm
- Extraction E: 4.5 kV/cm

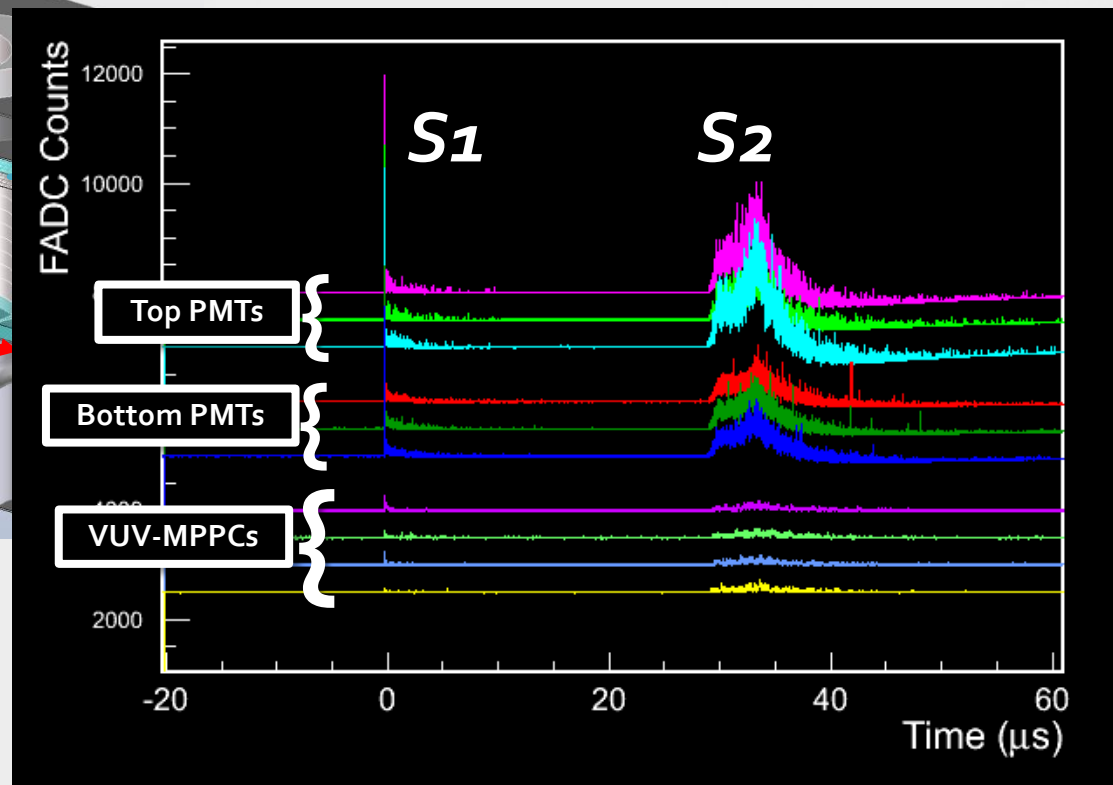
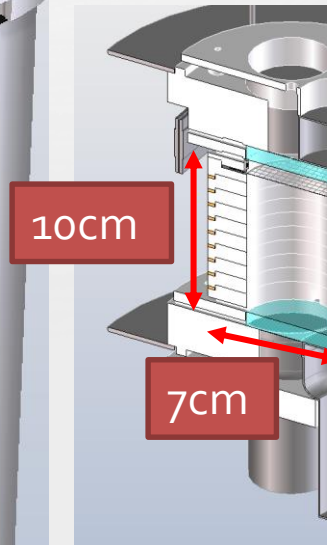
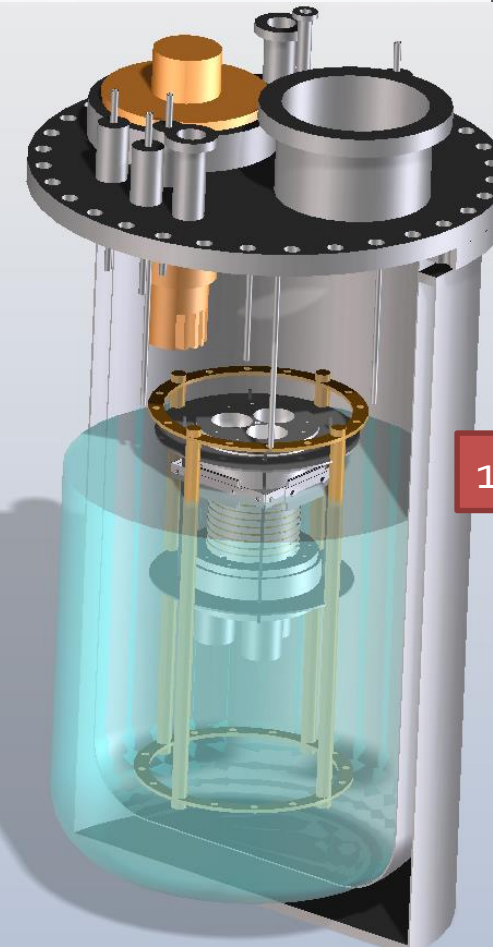
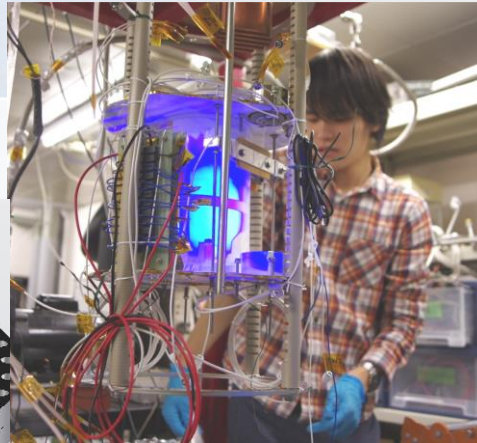

# Prototype Detector Results

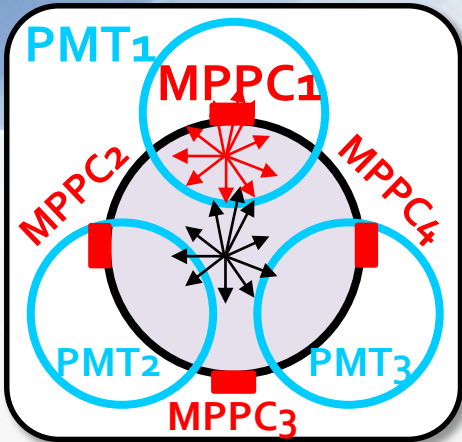

VUV MPPC improve spatial resolution near detector wall  
 → better fiducialization

~100keV<sub>nr</sub> (=60keV<sub>ee</sub>)

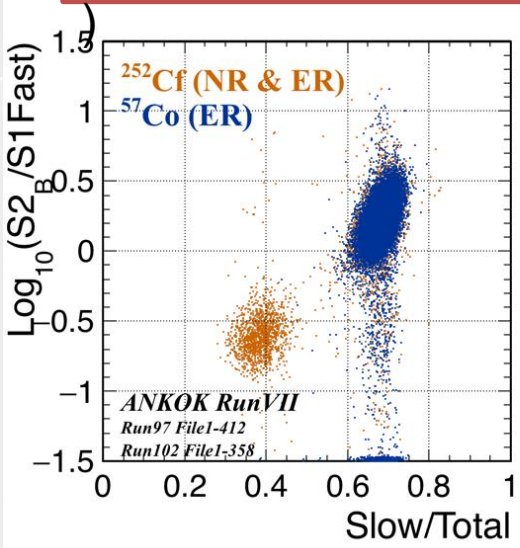

~30keV<sub>nr</sub> (=18keV<sub>e</sub>)

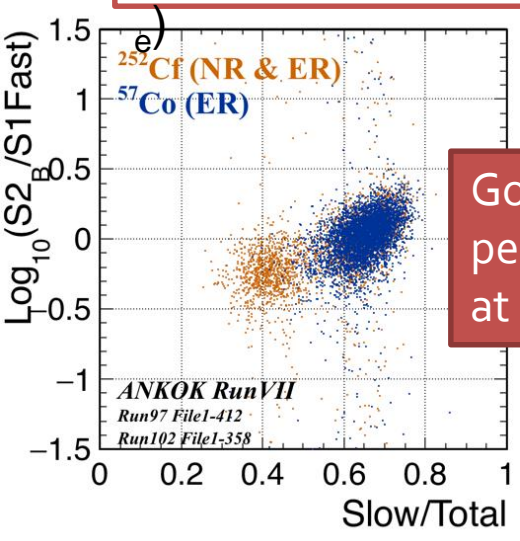

Good PID performance at 30 keVnr

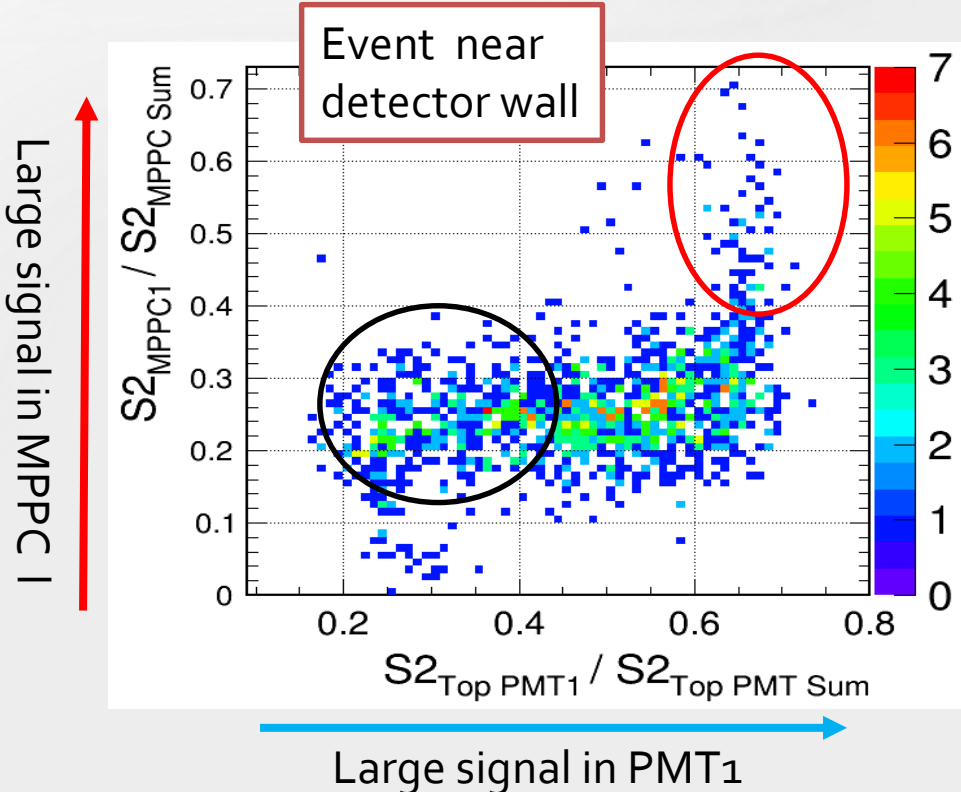

# Detector Simulation

- Geant4 based full simulation
  - Own Ar response model
    - similar to "NEST" package for Xe
  - Detector geometry, optical process, PMT response, noise, digitize..

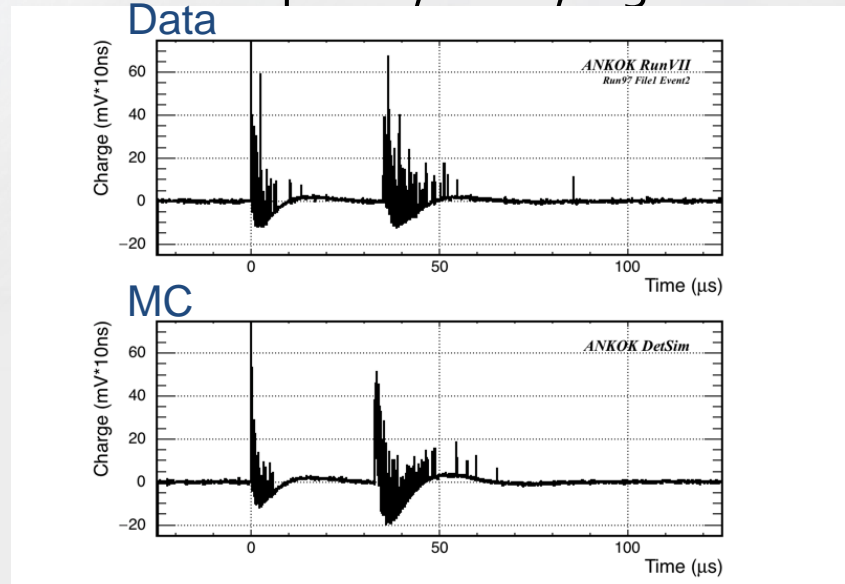
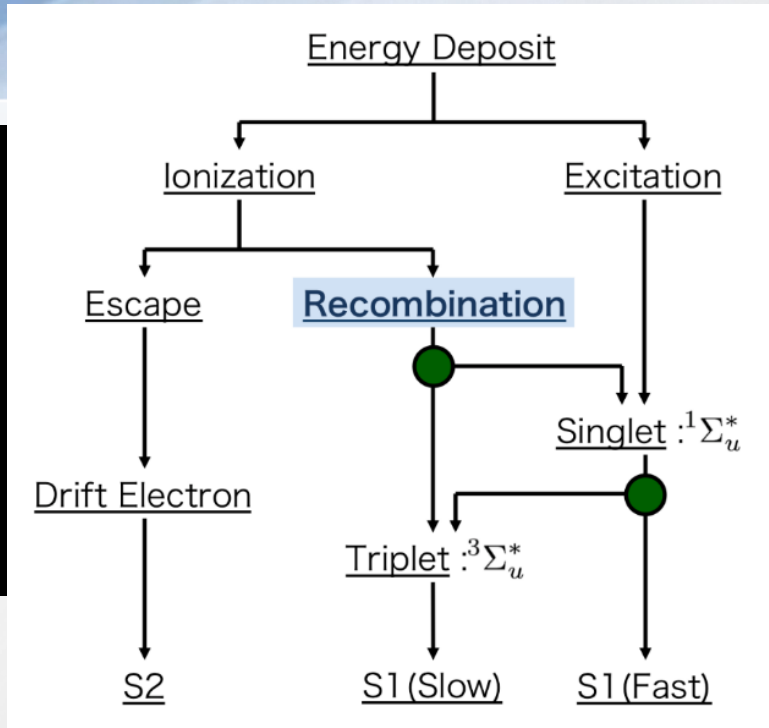

**S1**

**PSD**

**S2**

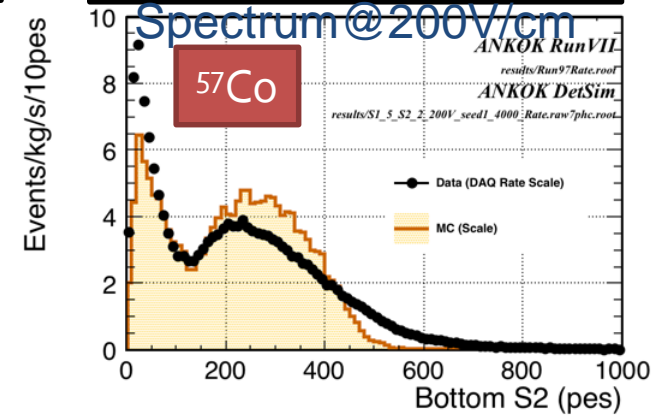
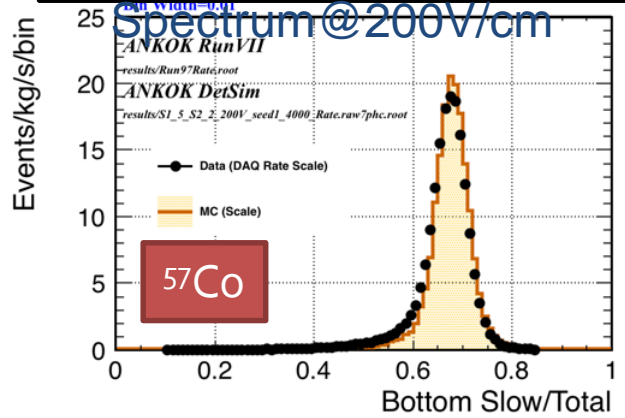
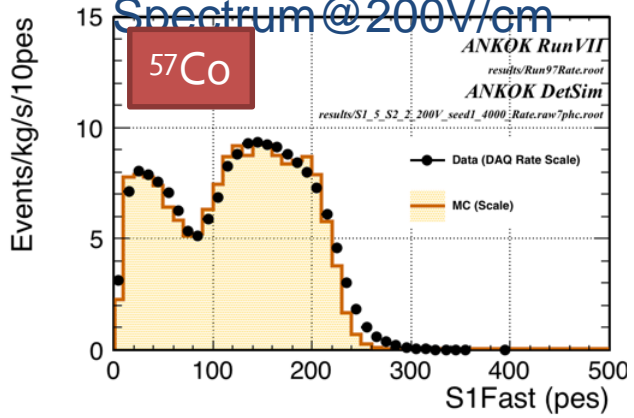

# Surface Run Analysis (ER events)

- Measure environmental  $\gamma$ -ray flux using 2" NaI detector
  - @Waseda teststand
  - $^{238}\text{U}$ -series,  $^{232}\text{Th}$ -series,  $^{40}\text{K}$ , cosmic  $\gamma$ , cosmic  $\mu$
- Simulate prototype LAr detector response
  - NaI-measured flux
- Good agreement between data and simulation
  - $^{39}\text{Ar}$  (1 Bq/kg) : x 1/100 smaller than environmental  $\gamma$  signal
  - $\gamma$ -ray from detector components (internal background)

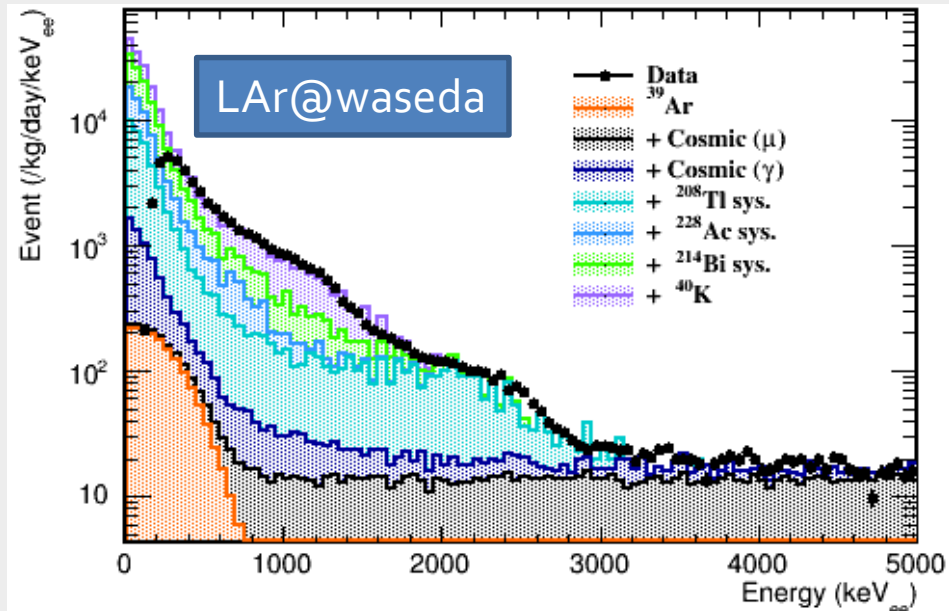
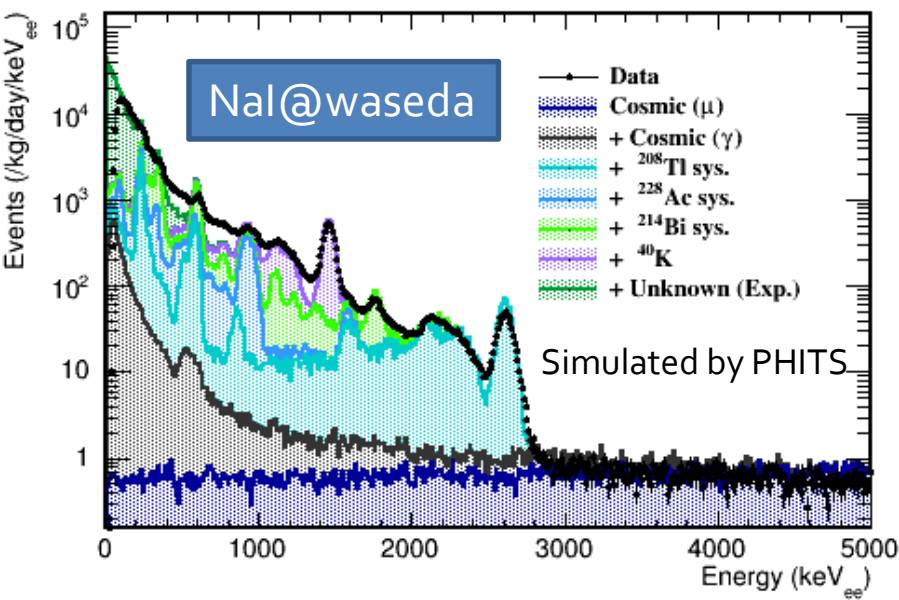
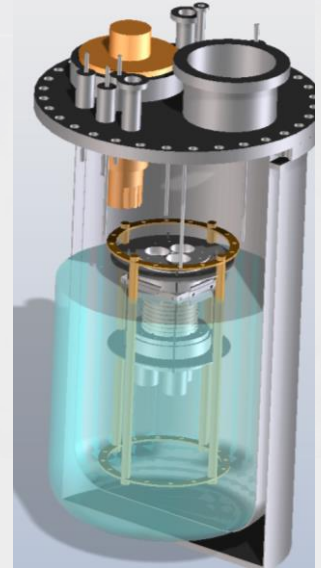

## 30 kg detector Surface Run @ Waseda

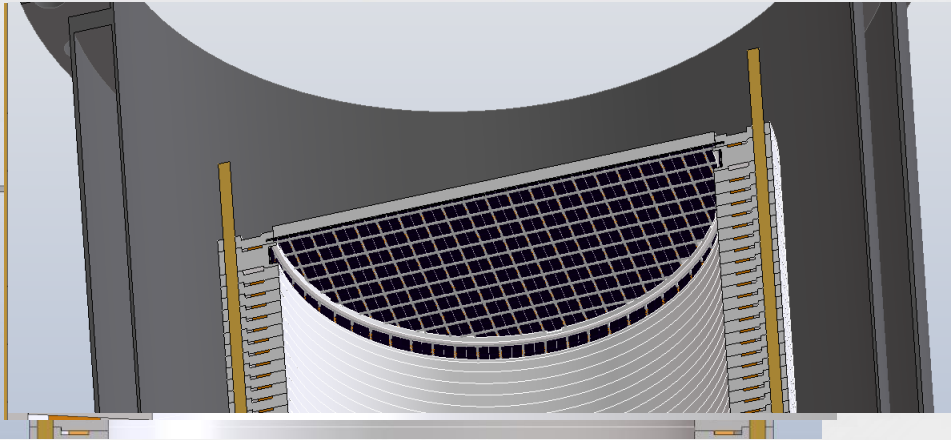

- 30 kg detector
  - $\phi 300\text{mm} \times H 300\text{mm}$
- VUV MPPC
  - case1: liquid surface wall
  - case2: replace top PMTs
- Surface run at Waseda
  - shield: Cu+Pb+Water

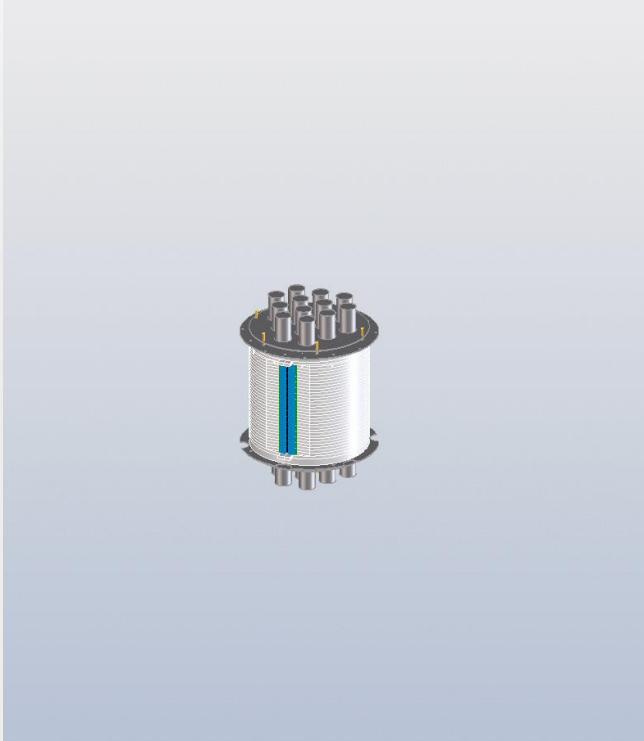

30 kg detector with shield

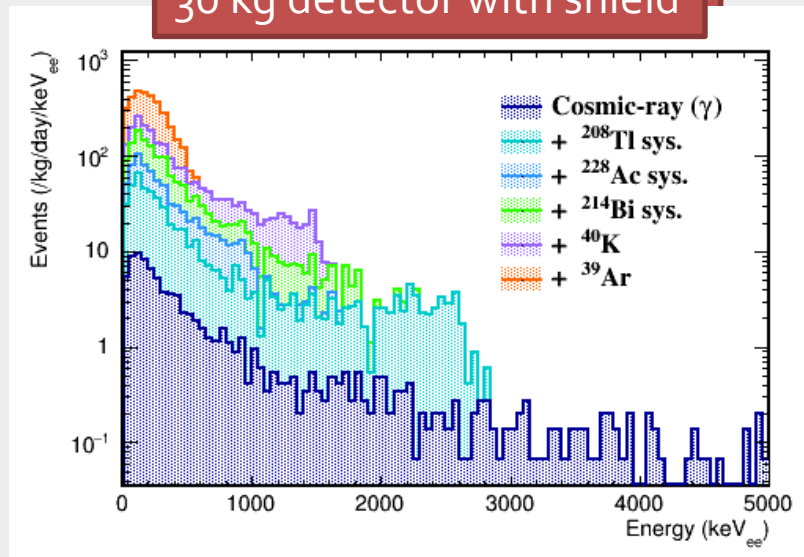

# Future Plan

## Underground Run @Kamioka

- Environmental neutron limits the WIMP search sensitivity
  - go deep underground
- ANKOK is adopted as a join-usage project of Kamioka Observatory
  - Expected neutron flux  $\sim 1/1000$  of surface (gamma flux  $\sim$  surface)
  - Detailed understanding of neutron flux is crucial for physics sensitivity estimation
- Environmental neutron/gamma flux measurements at Kamioka using liquid scintillator,  $^3\text{He}$ , and NaI detectors are ongoing
  - Collaboration with NEWAGE, CANDLES, NEWS, XMASS experiments

NaI Background Run at Kamioka

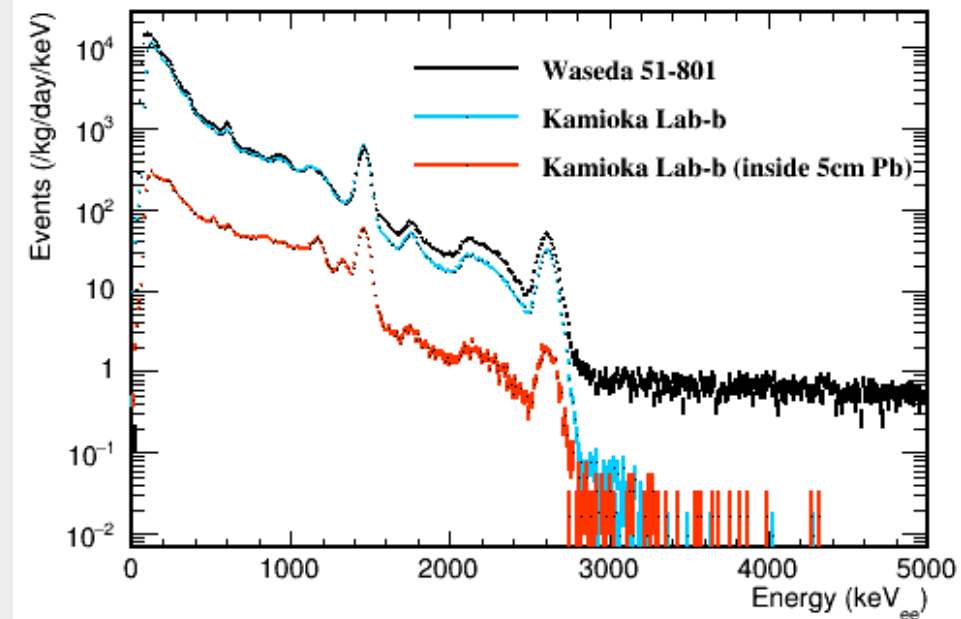
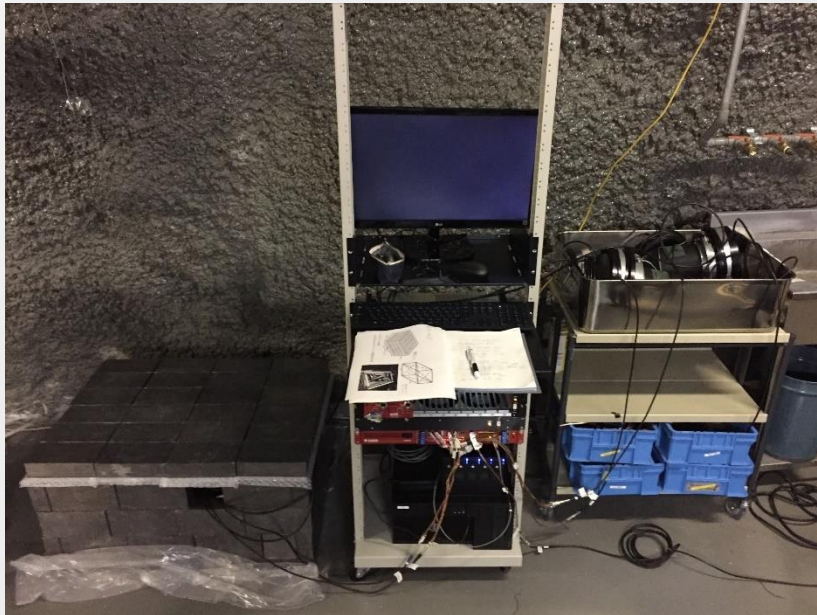

# Summary

- Physics Goal of the ANKOK Project
  - Low mass ( $\sim 10 \text{ GeV}/c^2$ ) WIMP search using double phase argon TPC technique
  - Compact and inexpensive detector
    - multiple detectors at several deep underground lab.
    - overall test of “DAMA” signal
- Ongoing efforts
  - Achieved highest level of LAr scintillation light detection yield
  - new photo-device (MPPC) directly detect LAr scintillation light (128 nm)
  - Good understanding of environmental gamma flux at surface (Waseda, Tokyo)
  - Design and optimization of the 30 kg detector
  - Environmental neutron flux measurement at Kamioka Observatory
- Plan
  - Construct the optimized 30 kg detector
  - Surface run at Waseda
  - Underground run at Kamioka Observatory

“ANKOK” Project

ANKOK = 暗黒 (= Darkness, Blackness)

“Arugon Nisou-gata Kennsyutuki” OK

アルゴン<sub>2</sub>相型 検出器

WIMP Dark Matter Search using Double Phase  
Argon Detector

# NaI Fit:

