



**High
Luminosity
LHC**

Assembly tooling for CRAB

Assembly tooling for CRAB Cryomodule:

1-Tooling overview SM18 zone

2-Assembly procedure of string

3- External assembly sequence gantry side



The HiLumi LHC Design Study is included in the High Luminosity LHC project and is partly funded by the European Commission within the Framework Programme 7 Capacities Specific Programme, Grant Agreement 284404.

Pierre MINGINETTE
09/11/2015 CERN/EN/MME



1-Toolings overview SM18 external clean room mounting area

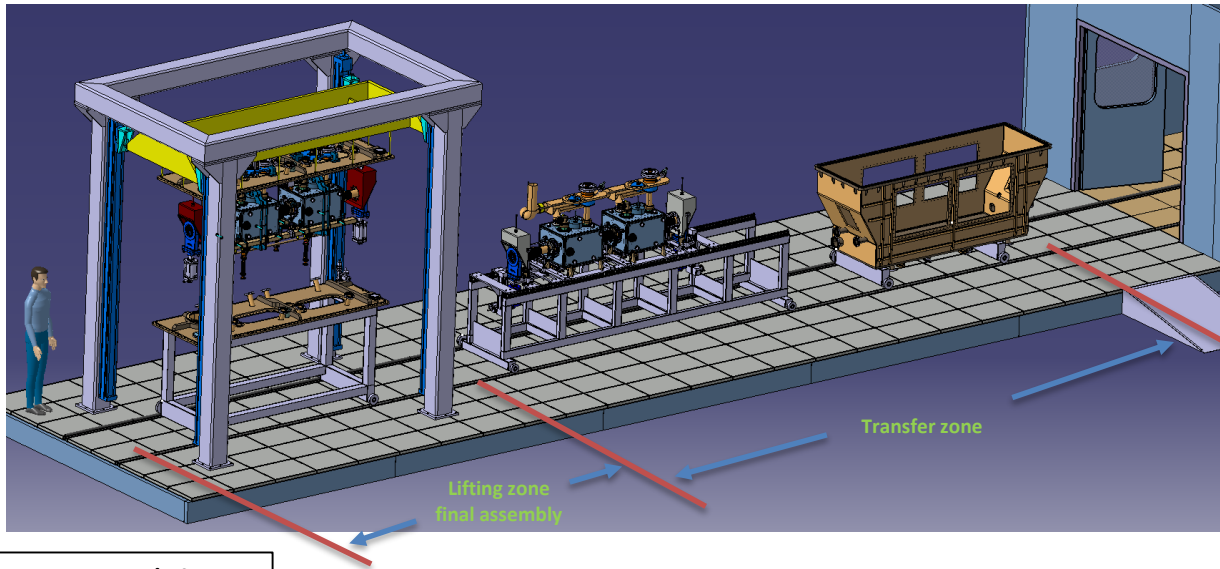

- 4 systems for all assembly sequence

Gantry CMU 2 tons / lifting stroke 3000 mm

Trolley for top plate /Magnetic shield/ thermal screen

Trolley for string assembly

Roller for vacuum vessel

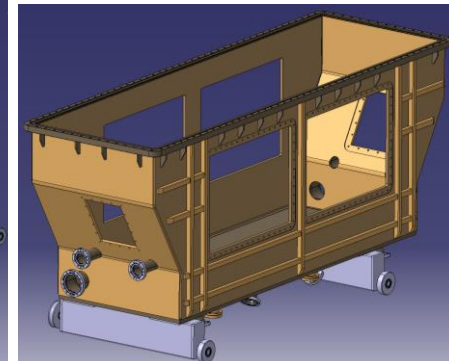
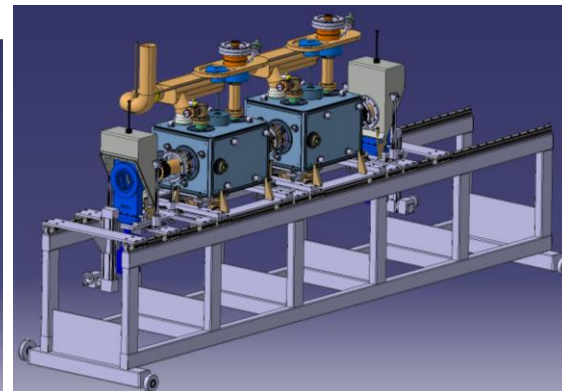
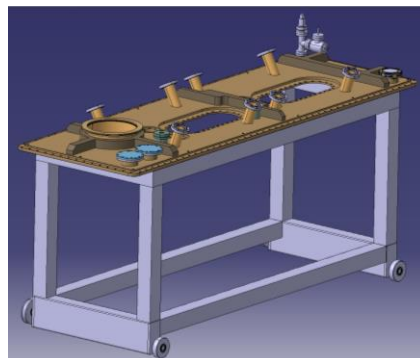
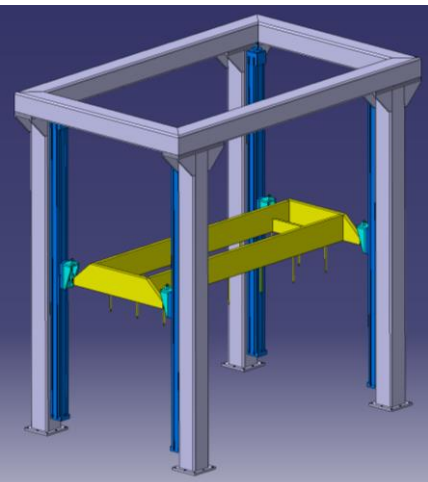

2-Assembly procedure of string

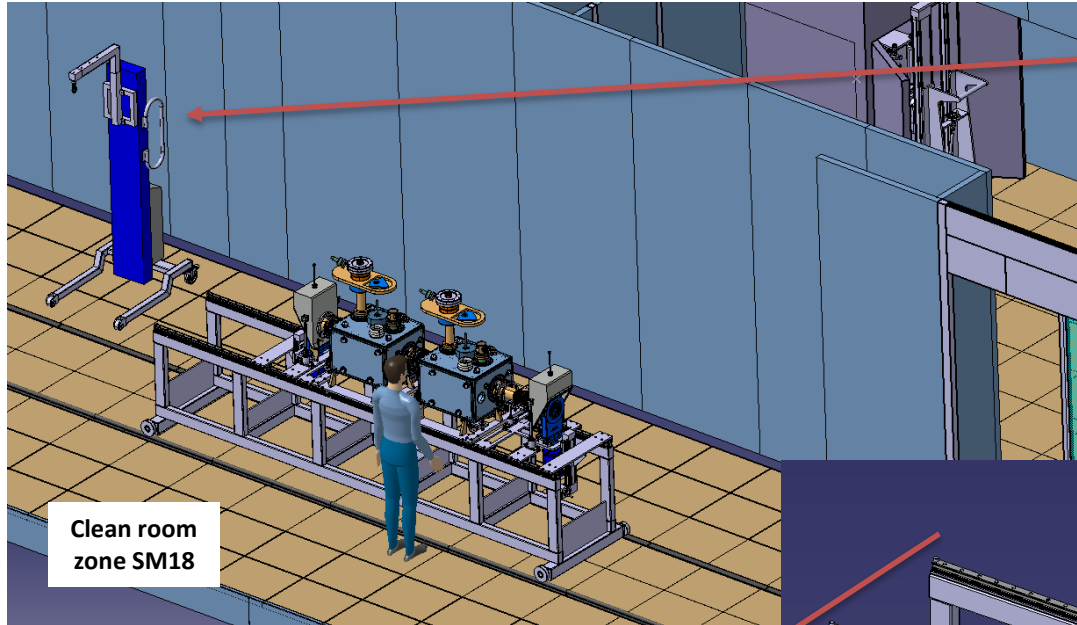

Clean room zone SM18

Manual crane for loading every components on trolley (9 components)

Aperture stroke 1000 mm

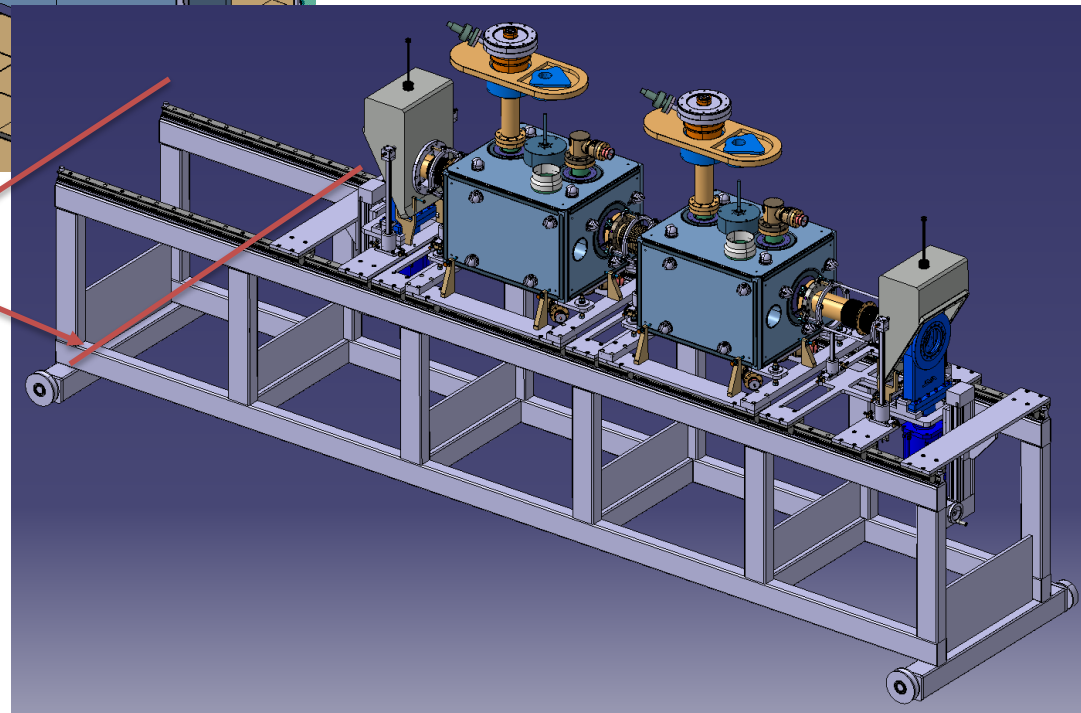

- Every components of string trolley compatible with Clean room ISO5.

***Every components are clean and closed by flanges**

Step 1 : Load every components in open position on trolley with manual crane

Step 2 : Alignment of cavity with the vertical and horizontal plan of external gantry

Step 3 : Alignment of every connection bellow in function of opposite flange of cavity

Step 4 : Final closure / open the flanges and connect every components with X displacement

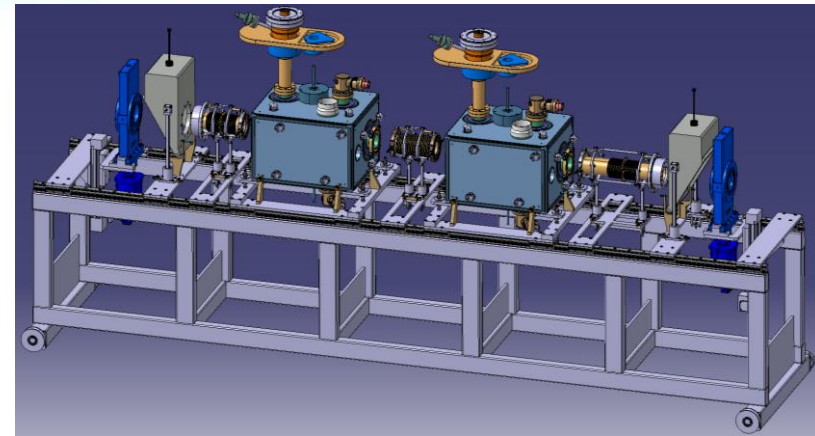

Details of adjustments on the string trolley

Rotation adjustment ring X axis

3 conical Holes around the flange on 2 side for alignment target

2 independents columns Z axis adjustment

2 independents screw Y axis adjustment

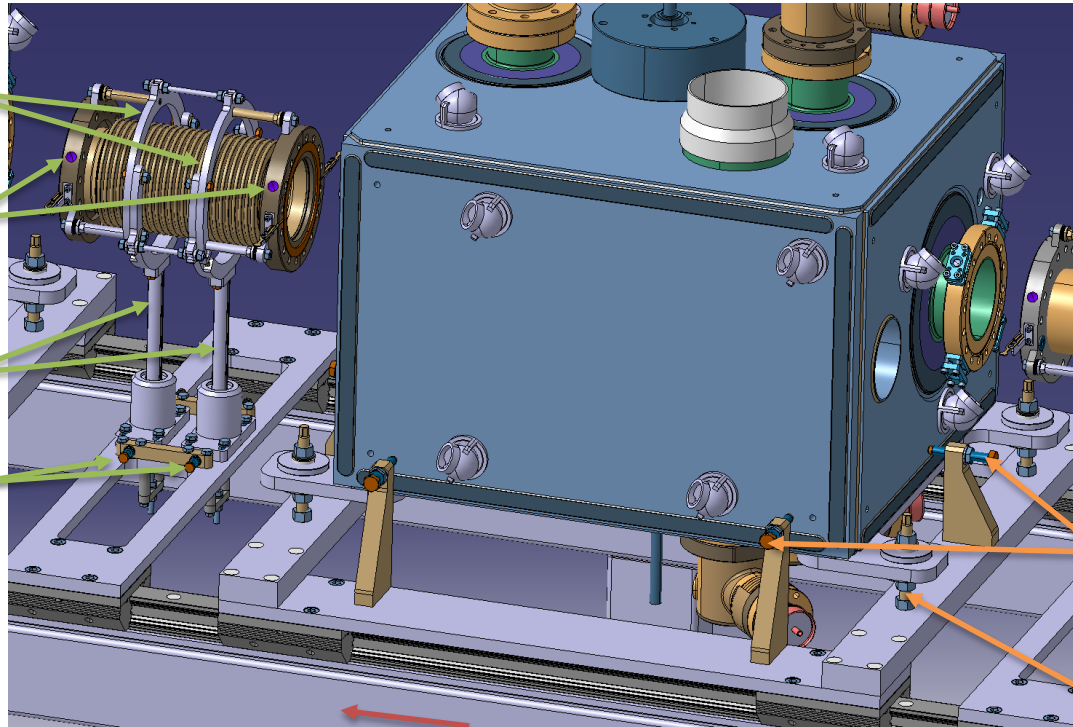

X free adjustment

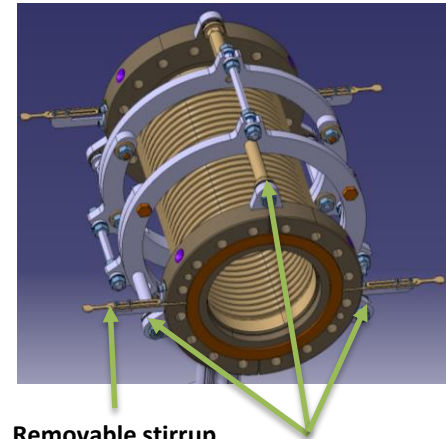

Removable stirrup
Retaining Cu Gasket

Mounting on spring washer small adjustment for final closure

X/Y Cavity adjustment 6 screw stroke +/-10mm

Z Cavity adjustment 4 screw stroke +/-10mm

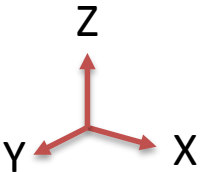

*Additional displacement for valve insertion on the valve box

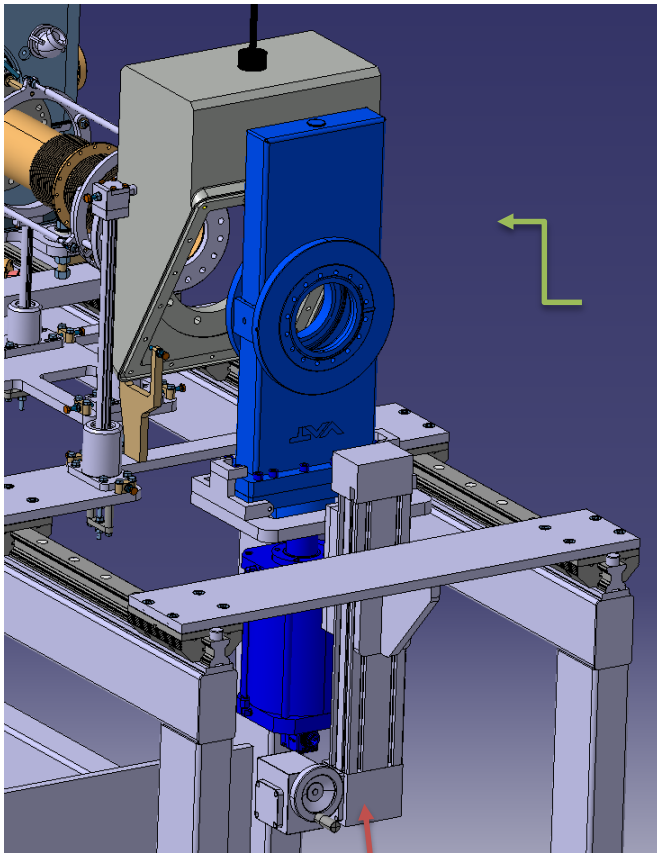

Manual linear actuator Z stroke 200mm
(-180mm/+20mm with beam axis referential)

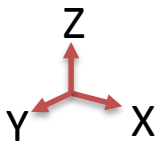

*Clean room assembly finished
Ready to go to the transfer zone

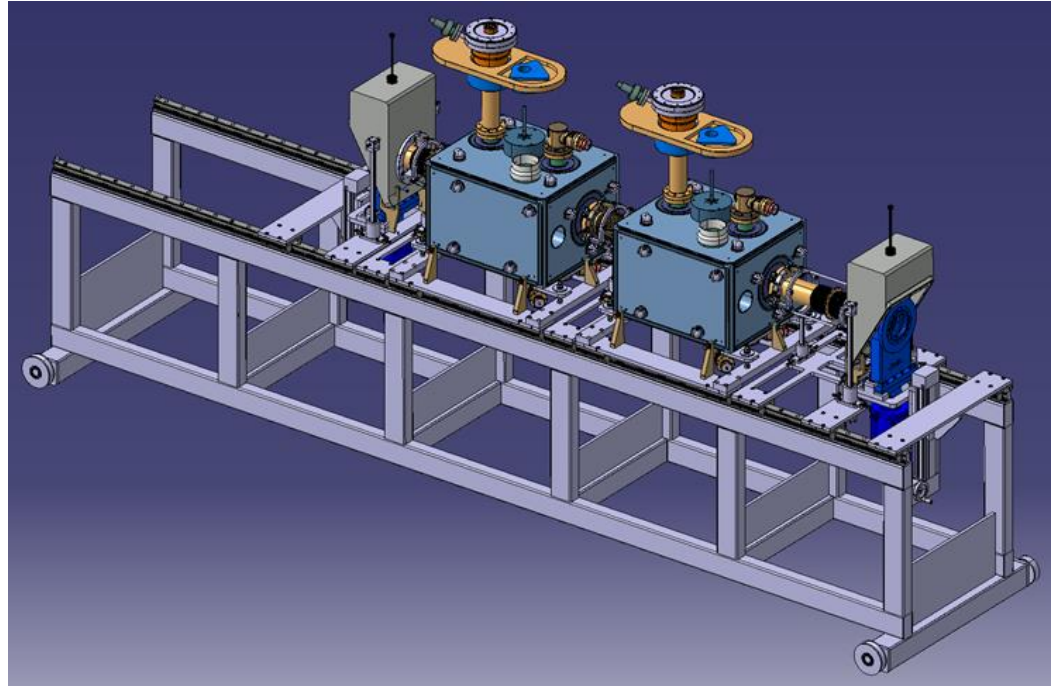

3-External assembly sequence

Step 1 : Insertion of magnetic shield on vacuum vessel

- Assembly and attached the magnetic shield on suspension frame of gantry / transfer to the vacuum vessel

Assembly magnetic shield

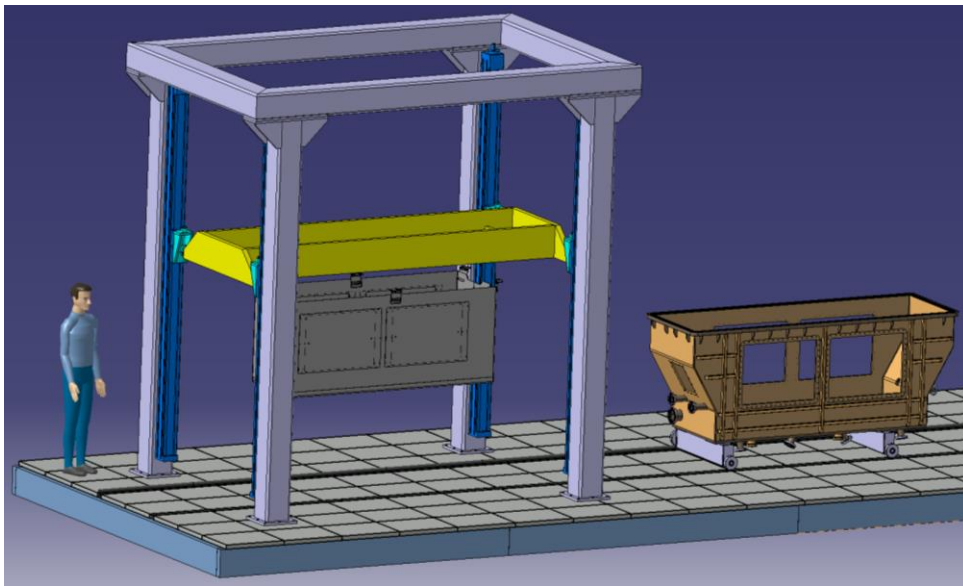

Magnetic shield insertion on vacuum vessel

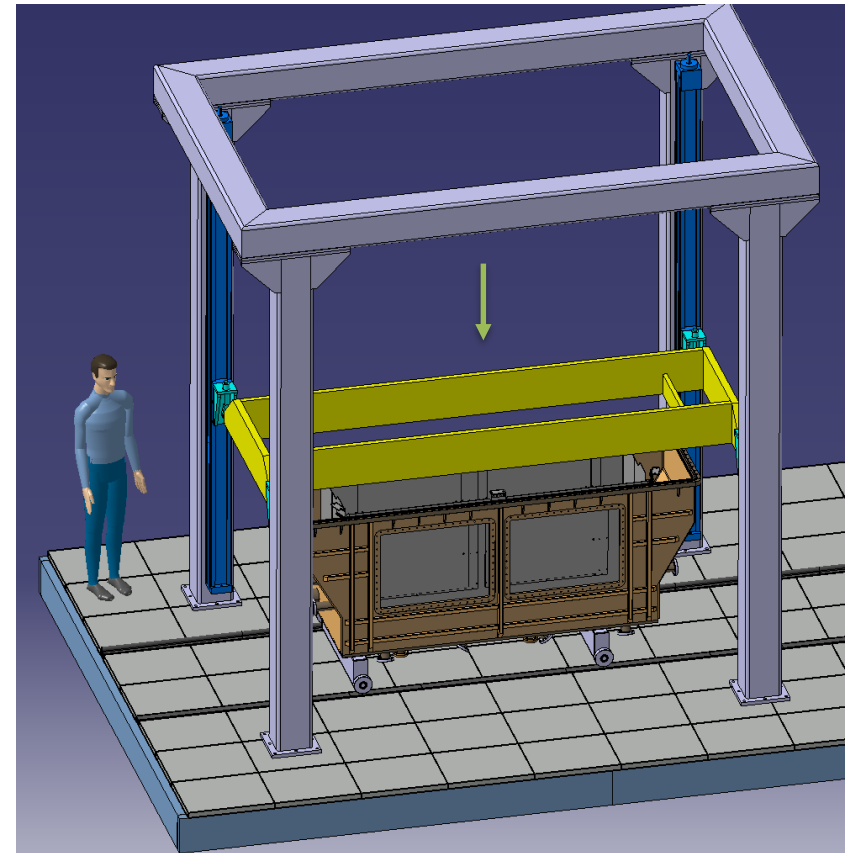

Step 2 : Transfer and fixed to suspension frame:

- Top plate / Upper plate of thermal shield / Welding the main Helium tank tube to cavity

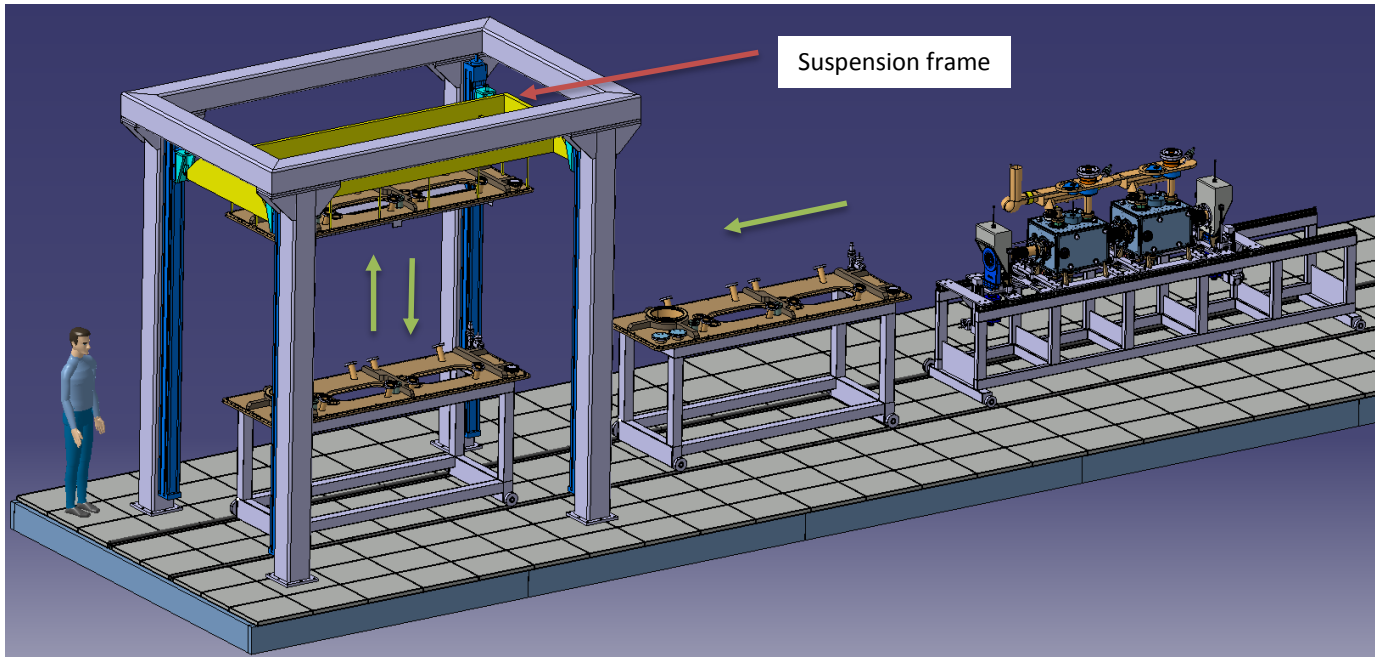

Suspension frame

Connexion tube Helium Tank

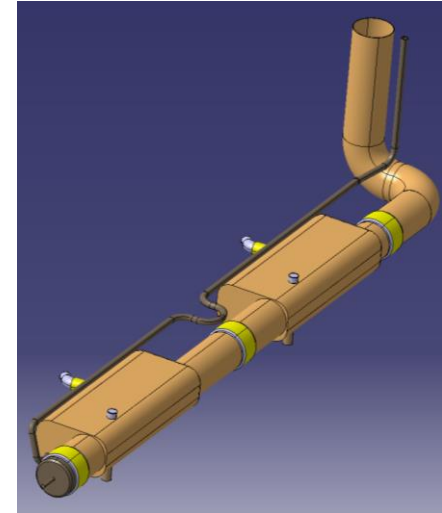

Top plate

Upper plate thermal shield

Welds

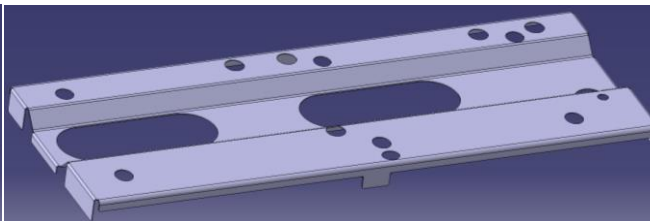
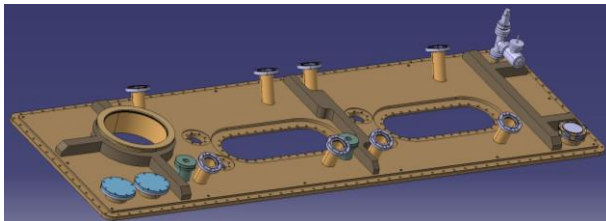

Step 3 : Transfer and Fixed string assembly on the top plate /Mounting alignments plates / Welding small tube on He tank

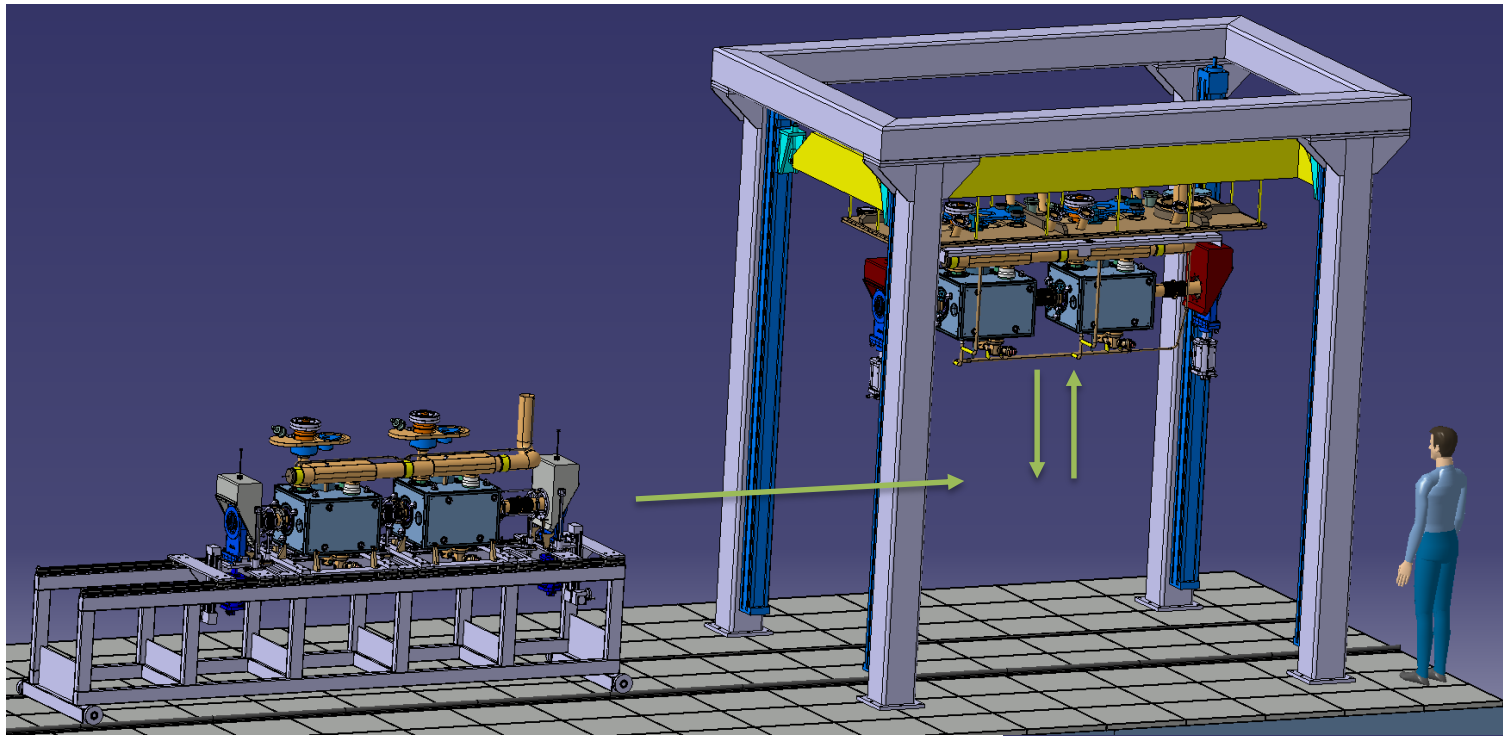

Alignments plates

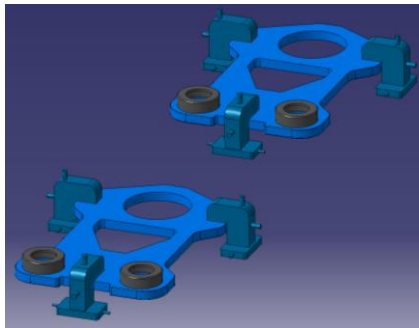

Small tubes on Helium Tank

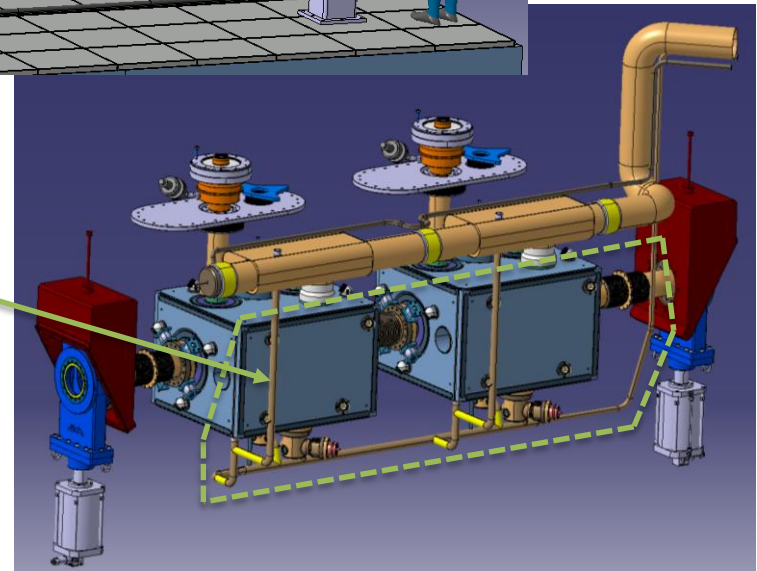

Step 4 : Mounting directly on the gantry:

- Alignment BECAM system / Tuning frame + tuner actuator / HOM coaxial connection

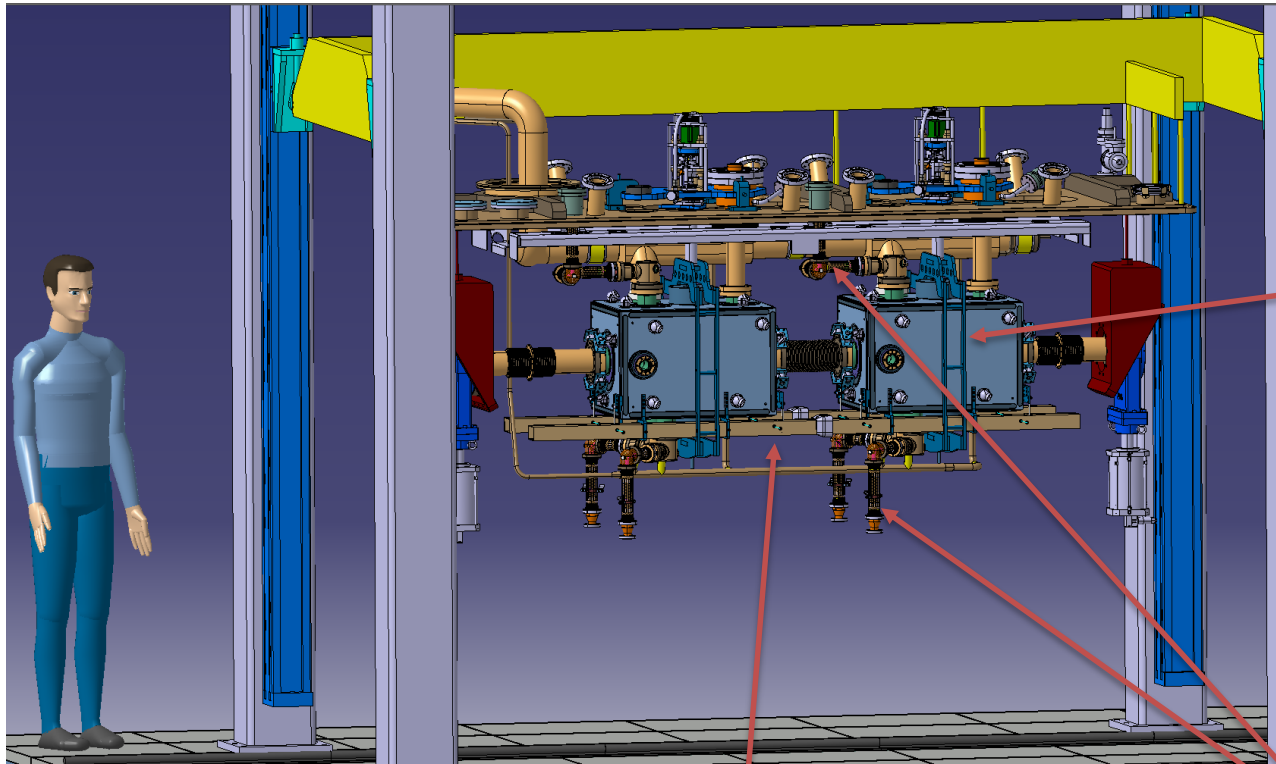

BECAM System

Tuning frame + tuner actuator

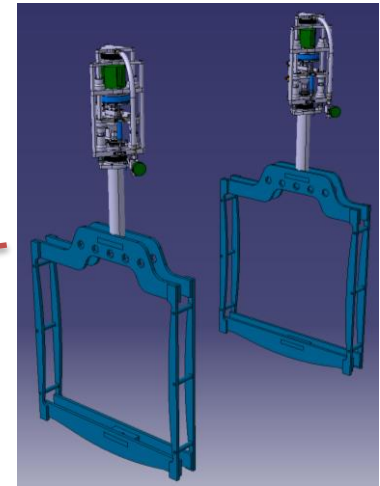

HOM coaxial connection

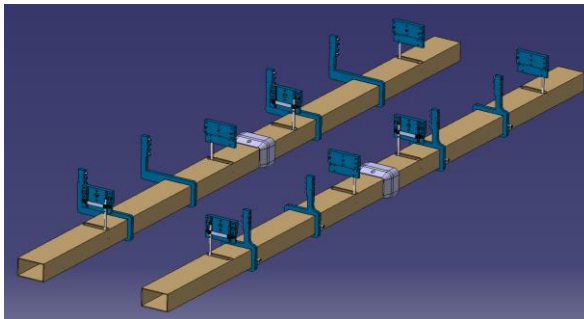
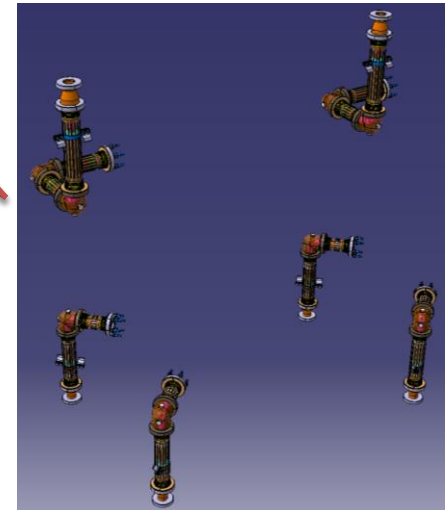

Step 5 : Mounting directly on the gantry:

- Thermal shield assembly / Transfer vacuum vessel + magnetic shield to gantry zone / cryostating

Thermal shield assembly

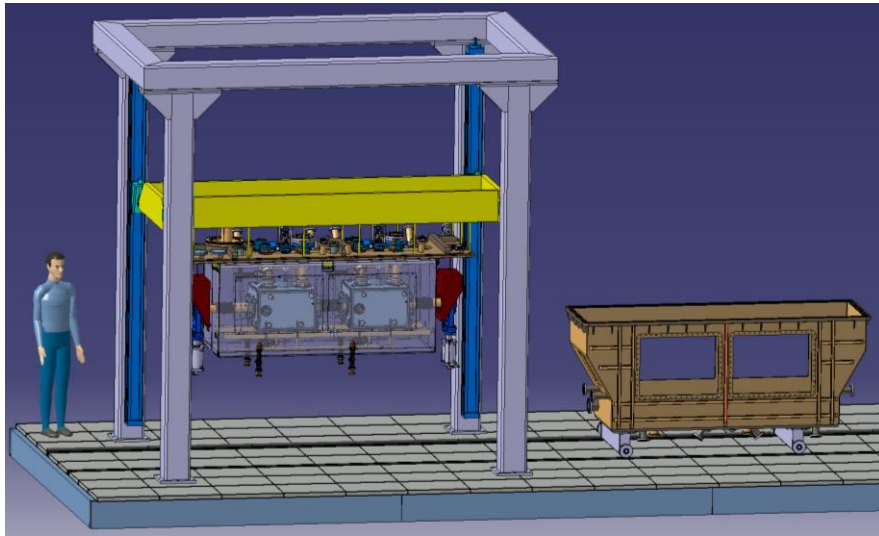

Insertion on vacuum vessel

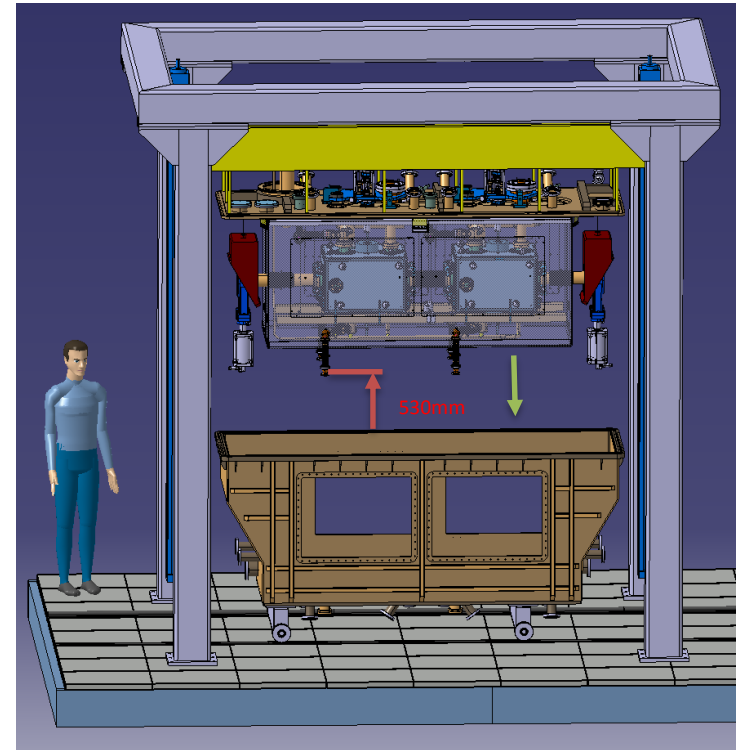

Cryostating

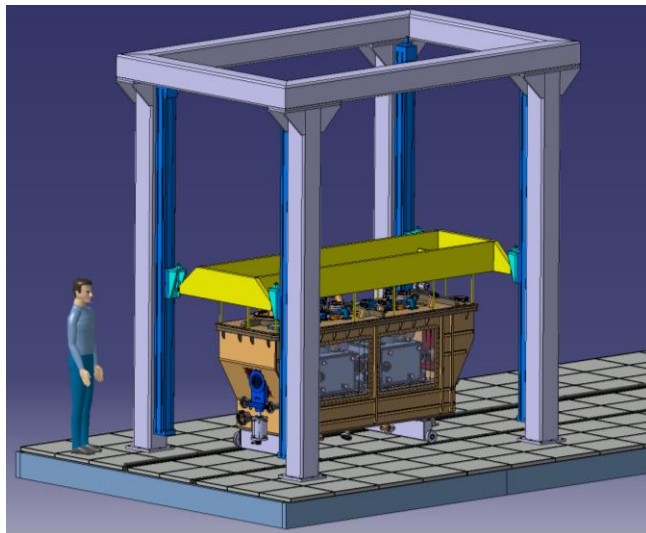

Thank you for your attention



High Luminosity LHC



The HiLumi LHC Design Study is included in the High Luminosity LHC project and is partly funded by the European Commission within the Framework Programme 7 Capacities Specific Programme, Grant Agreement 284404.

